

 Llewellyn's Golden Dawn Series

Z-5

**Secret Teachings of
the Golden Dawn**



Book 1
The Neophyte Ritual
0 = 0

Pat Zalewski

LLEWELLYN'S GOLDEN DAWN SERIES

Z-5

*Secret Teachings of the
Golden Dawn*

*Book, I
The Neophyte Ritual*

0=0

b y

Pat Zalewski

1 9 9 1

Llewellyn Publications
St. Paul, Minnesota 55164-0383, U.S.A.

Contents

<i>Foreword, by Soror M.A.A.E.M.</i>	xi
<i>Introduction</i>	xiii
Part 1 - The Ritual	1
The Neophyte Ritual of Whare Ra Temple.....	3
Part 2 - The Commentary	29
1 A Commentary on the Neophyte Ritual	31
2 Symbolism of the Temple.....	73
3 The Pillars	121
4 Symbolism of the Opening.....	139
5 Symbolism of the Admission of the Candidate	159
<i>Lecture on 0=0 Grade</i>	187

Foreword

With the publication of this volume, Llewellyn Publications begins a new era of Golden Dawn history and magical practice. Whether the student is a member of a group, a temple, or a solitary practitioner, he/she will be able to use this information to enrich his/her magical practice.

The 0=0 Commentary is the first of five books which will explain in depth the Neophyte and Elemental Grade initiation rituals. Although some of the material is familiar, there is much in the way of new data, instructions, and explanation of symbolism which has never been in print before now. Much of the information is from original Stella Matutina, Whare Ra, and Smaragdum Thalasses Inner Order Documents.

The GD rituals that have been published for the past fifty years are merely skeletons of the ceremonies. In other words, they explain merely what happens on the physical plane. These explanations came primarily from Z.1 and Z.5 documents, which were intended for the newly initiated Adeptus Minor who had just entered the Inner Order. The AM had just begun the Inner Order journey. It rather parallels the status of the Neophyte being newly initiated into the Outer Order.

The Inner Order documents presented in this and further volumes were intended for the seasoned Adept who was accomplished in the Inner Order procedures. The astral workings of the temple are described, as well as instructions on the god-form assumption and manipulation of the five currents of energy which are present in the O=O ceremony. For the first time, the currents of Aroueris, Isis, Nephthys, Thoth, and Osiris are described. As one reads this book and begins to understand the true meaning of the rituals, it becomes clear why the officers of the temple were to be trained Adepts. The balance, clarity, and power required to correctly perform the ceremonies are easily noticeable.

Also in the book, Zalewski describes in detail the manipulations of the Candidate's aura by the temple officers. How the individual currents affect the Candidate at each level of the ritual, how and when he is exposed to the Light of the Higher Self, and how he is protected at all times from the Evil Persona and any other negative forces is revealed. It gives one a sense of respect for the Adepts who perform the ritual and an understanding of the amount of time and effort spent to be able to perform it effectively.

Israel Regardie himself stated that a person could perform self initiation. He also mentioned personally to me that he felt that the Neophyte (O=O) initiation and the Adeptus Minor initiation rituals were of the utmost importance and should be experienced if the student had the opportunity to participate in them. With the information provided in this book, the reader may begin to see the true value these initiations play in the development of the student's psyche and subsequent evolution towards the Light and Conversation with the Holy Guardian Angel.

Regardie's own comments on the rituals are rather apt:

From one point of view the officers employed in these Rituals represent just such psychic projections. They represent, even as figures in dreams do, different aspects of man himself—personifications of abstract psychological principles inhering within the human spirit. Through the admittedly artificial or conventional means of a dramatic projection of these personi-

fled principles in a well-ordered ceremony a reaction is induced in consciousness. This reaction is calculated to arouse from their dormant condition those hitherto latent faculties represented objectively in the Temple of Initiation by the officers. Without the least conscious effort on the part of the aspirant, an involuntary current of sympathy is produced by this external delineation of spiritual paths which may be sufficient to accomplish the purpose of the initiation ceremony. The aesthetic appeal to the imagination—quite apart from what could be called the intrinsic magical virtue with which the G.D. documents Z.1 and Z.3 deal at some length—stirs to renewed activity the life of the inner domain. And the entire action of this type of dramatic ritual is that the soul may discover itself exalted to the heights, and during that mystical elevation receive the rushing forth of the Light.'

The reader is about to view the 0=0 ceremony from a depth that was unavailable to either Regardie or Aleister Crowley. The magician will now be able to perform the ceremonies with much more understanding and effectiveness. With practice and perseverance, he/she has a great chance of fulfilling the purpose for which the rituals were originally designed.

I personally find the 0=0 ritual to be one of the most beautiful and moving ceremonies which a group can perform. In a full temple setting, with the Pillars, the robes, weapons, banners, and officers, it is something truly unique. When performed to its fullest potential, it affects not only the Candidate and the officers but all members present in the hall. When one is performing the role of an officer, the influx of energy and Light created brings one into direct contact with his/her spiritual potential and powers. Anyone wishing to achieve this state, and who is willing to persevere through a series of often dramatic transformations, will indeed be well rewarded by the greater awareness of his Higher Genius.

—Soror M.A.A.E.M., Co-Chief
Ra-Horakhty Temple
Hermetic Society of the Golden Dawn
Federal Way, Washington

Introduction

The concept of writing commentaries on the Neophyte Ritual (0=0) of the Golden Dawn was initially formulated as an Order document called the Z.5. We started writing this document in 1982, the year our Thoth-Hermes Temple was chartered by W. H. (Jack) Taylor. Taylor was a former Hierophant (of 7=4 grade) of the New Zealand Temple, Whare Ra. This temple was founded in 1912 by Dr. R. W. Felkin.

The Z.5 document was originally intended to be restricted to members of the Inner Order of Thoth-Hermes. It included many of the "word of mouth" teachings passed on by Taylor and other Inner Order Adepts from Whare Ra under whom we trained. The Z.5 was written to fill in information left out of two other Order papers, the Z.1 and Z.3. It also was designed to bridge the gap between the two papers.

The Z.1 paper is a technical explanation of the meanings and descriptions of the temple officers. The Z.3 is a clairvoyant description of the admission of the candidate. [The Z.1, Z.2, and Z.3 documents can be found in Book 5 of *The Golden Dawn*, edited by Israel Regardie, Llewellyn, 6th Edition, 1989. The Z.1 document is entitled "The Enterer of the Threshold." The Z.2 document is

entitled "The Formulae of the Magic of Light," and the Z.3 is entitled "The Symbolism of the Admission of the Candidate."]

This book has been designed for the experienced Golden Dawn practitioner. It contains: 5=6 explanations of the 0=0 Ceremony, previously unpublished teachings from the 6=5 and 7=4 grades of the Stella Matutina, and later teachings from the Smaragdum Thalasses. "Smaragdum Thalasses" is the New Zealand name given to the order after Whare Ra withdrew from the Stella Matutina in 1933.

We have brought all of this information together in a unified format rather than stretch it out over the three Inner Order grades. Examples of this consolidation are given in "The Control and Functions of the Officers on the Dais," Chapter 2.

For some readers of this book, there may be areas that are initially incomprehensible. Dedicated reading and study will eventually bring an understanding of the material presented. For others, who have studied on their own or through various temples, we hope that the additional material will give more insight into the 0=0 grade.

When we first decided to do this book, we were faced with the problem of what to do with the existing Z.1 and Z.3 documents and their colorful but somewhat archaic language. We were not sure whether to rewrite them, omit them, use only our additional material, or leave them in and blend them in with the newer material so that the whole package could be presented in full. Ultimately, we chose the latter, which saved the reader from going book to book trying to fit the puzzle into place. In doing this, we have re-formatted the Z.1 and Z.3 documents to eliminate duplicate material. The importance of understanding the technical aspects of the Neophyte Ceremony cannot be overemphasized. It is the backbone of the Z.2 paper. This paper outlines ritual ceremony for Evocation, Consecration of Talismans, Invisibility, Transformations, Spiritual Development, Divination, and Alchemy. In the Neophyte Ritual of the Z.2, the Adept assumes the role of the Hierophant. The Hierophant must understand every aspect of what is happening in the ritual so that he/she can control the ceremony and give the forces life. He/she must also be able to dissect each layer of the ritual. If one area is lacking, he/she must be able to

counterbalance the energies so that harmony prevails throughout the ceremony.

Both the Z.1 and the Z.3 documents were written very early in Golden Dawn history, around 1892 or earlier—barely four years after the first Neophyte Ceremony was conducted. After this, there was little input of this depth on the subject of the Neophyte ceremony by later Temples.

In 1903, the Golden Dawn split into two factions. The splinter group, led by Robert W. Felkin, formed the Stella Matutina, which retained the bulk of the Golden Dawn's Inner Order. Most members remained in the Order until World War I. Even in the 1920s, there were still some original Golden Dawn Adepts in the Stella Matutina. The 30 or so years of ritual experience gained in both Orders were shared with other Order members. A good example of this was the Hermes Temple in Bristol, England. During the 1930s, the Hermes Temple had a number of members who had been trained by Golden Dawn Adepts.

Israel Regardie, the editor of *The Golden Dawn* and several books on the Order, was a member of the Hermes Temple in Bristol during the 1930s. According to him, when questioned on this point in 1983, his only temple contacts during that time were with the Chiefs. He never met other members, though one person came to witness the consecration of his Elemental Weapons—which some, surprisingly enough, considered a major event in a temple. Because of this, Regardie was not aware that there were other members of the order with ritual experience.

Actually, the temple had a number of members with extensive ritual experience, but they had chosen to isolate themselves from other temple members during this time. Some of these members had been taught by Golden Dawn Adepts. Though well into their 70s, they were still actively engaged in Golden Dawn ritual.

The New Zealand Temple, Whare Ra, was also a good example of this cumulative type of teaching. Dr. Felkin was in charge of ritual training at Whare Ra. Under his guidance, Whare Ra members were the best trained in ritual magic of all the Golden Dawn temples, including the Hermes, Amour', and Isis-Urania temples. This assertion is based on the opinions of visiting members of those

temples who came to New Zealand.

Dr. Felkin ran ritual training in the New Zealand Order like a military operation. He went into extraordinary detail on how and what was happening. Around 1920, a former Golden Dawn Adept (from the old Isis-Urania Temple) and his wife visited Felkin in New Zealand. They expressed surprise at the ritual ability of some of the early Whare Ra Adepts. The training procedures advocated by Felkin, in their opinion, far outstripped those they had seen in the old Golden Dawn, as well as those of the American temples that they had previously visited.

In the late 1920s, a Whare Ra Adept by the name of Hugh (Euan) Campbell went to England to study the Dee manuscripts at the British Museum library for two years. While there, he became friendly with Langford Garstin, Chief of the Alpha et Omega (A.O.) Temple. Campbell's diary notes make the comment that the rituals in this temple were "slip shod" (he attended some Neophyte rituals and a 5=6 ritual) and lacked any real determined effort. Though Campbell was friendly with Garstin, he found that his Alpha et Omega Temple cousins treated rituals as a "chore that was simply tolerated." Garstin, in fact, tried to persuade the young New Zealander to stay in England and join his temple. Campbell had a high respect for Garstin, and found his ability and knowledge to be the exception rather than the rule in the A.O.

Whare Ra's isolation, in the small country village of Havelock North, had its advantages. A large number of this temple's founding group were extremely clairvoyant. When the temple was founded in 1912, Felkin found himself with a tight-knit group of religious devotees that had much to offer but no direction to go toward. When they applied themselves to the Golden Dawn rituals, it was done in the manner of religious fervor and fanaticism rarely seen outside the Middle Ages, and I make this comment with the greatest respect.

From 1912 until the 1940s, when Whare Ra was at its peak, much of this devotion to ritual produced some surprising results. For example, some Adepts would clairvoyantly check each other, during the performance of rituals, by viewing the state and color of the participants' auras.

My own experience of this type of checking procedure came from Jack Taylor. He used to make me create the temple god-forms of the 0=0 grade in the astral—with all the correct coloring_ He would then proceed to check each one and give a comment on whether it was correct or not. If not, I would then have to start again_ One day, I decided to test him on this by creating the form of a lion in the Invisible Station of Horns. When he got to this form he told me, rather dryly, that I should try a little further north—like Egypt —and leave the rest of the pride behind. I never again tested his abilities. Admittedly, abilities such as Taylor demonstrated were rare, but the number who possessed this in the early days of Whare Ra was quite abnormally high when compared to other temples.

I do not wish to give the impression that the greater number of Whare Ra Adepts knew more about ritual than their old Golden Dawn counterparts, because they did not. However, an inner core did exist who excelled in ritual work.

Whare Ra members were taught courses in Tarot, astrology, and Enochian work, along with the Z.2 documents, which were optional studies. The first things taught new members, however, were the mechanics of ritual. Some older members considered these to be of singular importance, and taught them to the detriment of the other studies. Students were required to keep their eyes on the cracks of the concrete to locate exact places to stand and walk during the rituals. This caused a great deal of pressure on Adepts and a number left the Order because of it. Those who survived under this type of training were mostly strict disciplinarians.

Before World War II, training by word of mouth was quite detailed, and it produced a number of Adepts of high caliber. In the final stage of Whare Ra's existence, however, from 1959 to the temple's end in the late 1970s, this method of training deteriorated, and the temple failed to produce the skilled leadership needed to sustain it. Ritual training was inadequate and lacked the necessary supplemental support of the Z papers. Adepts had to write their own papers and formulate their own opinions as to what went on. As a result, the last three Chiefs of the Order were unable to reach the skill level of previous Chiefs, and the temple disbanded.

It is unfortunate that, in the final days of the temple, members

with the most ritual understanding failed to rise to any real position of power. Those who were in charge had little knowledge to pass on to others—with the exceptions of Taylor, Campbell, and one or two others. This was aptly illustrated by a humorous anecdote related to us by a couple that belonged to the temple during its final stages.

The couple reported that they had been instructed by a former late Chief to "walk like an Egyptian" during rituals. The couple, puzzled by what this meant, asked for further illumination. The Chief, obviously unsure of what it meant herself, ignored their request. When we heard this, we were reminded of the pop tune and video of the same name by the Bangles. To this day, we cannot hear the tune nor watch the video without bursting into laughter.

When we first got interested in magic, we studied the Golden Dawn rituals from Regardie's published works. When put to the practical test, this information on rituals left quite a number of questions unanswered. It was not until our period with Taylor, and also other Adepts who helped, that we began to truly understand ritual work and record this understanding on paper. We began to feel like Carlos Castaneda felt in the presence of Don Juan (see *The Teachings of Don Juan: A Yaqui Way of Knowledge*) and were forever taking notes on instructions, conversation and general folklore from Whare Ra. We knew that the opportunity we had was a once-in-a-lifetime experience and should not be lost. We found that we virtually had to start again from scratch.

As we conducted the physical actions of each ceremony, we had to learn the functions on the many different levels of the astral, about which virtually nothing had been written in the published papers of the Order. This type of teaching was the "word of mouth" type that had been handed down from Hierophant to Hierophant since the formation of the Order in England.

Over the years of our association with Taylor one thing became obvious—we had much to learn about ritual work. We were extremely fortunate to come under Taylor's wing. We also were enriched by our acquaintance with the elite circle of ex-Inner Order Whare Ra members, who continually helped us and gave us advice over the years.

It is unfortunate that some of the published comments about the

Stella Matutina are blatantly contemptuous. Reading these accounts, one would consider that most of the members were a bunch of incompetents who were mixing in things they knew little about. Most of this stemmed from Regardie's comments of his experiences in the Hermes Temple and the tampering with the ritual documents. This, however, was not always the case in the New Zealand Temple. While it is true that their scholarship left a lot to be desired in some areas of the Order's teaching, they were quite exceptional at ritual magic.

The best I have ever seen was Taylor, and the members of the Order of the Table Round. This was a small Arthurian Order that Felkin brought to New Zealand along with the Golden Dawn. It had a large number of Whare Ra, Inner Order, members within it.

When we were initiated into this side Order (before we were initiated into the Golden Dawn, or the Smaragdum Tha la sses, as it is called in New Zealand), all those on the dais and most of the floor officers were Inner Order Golden Dawn members as well. This was a totally different experience from any dry Masonic type Order that we had experienced before. Here, it seemed to us, was ritual magic in its essence. The experiences at the hands of this well-drilled collection of officers left their mark on us. While we had practiced Golden Dawn rituals before, they were nothing compared to this level. The problem, of course, was our own lack of experience and our inability to recognize the ritualistic signposts.

Over the next few years we found we were swamped with the amount of unpublished material on these rituals. Taylor, to my mind, was something of a ritualistic genius who could dissect and instantly point to the problem. One of his favorite anecdotes was a conversation he had with Mrs. Felkin back in the 1930s. Jack commented, after a Neophyte practice, that everyone had managed their parts without making a mistake. Mrs. Felkin countered that there might have been perfection in the rendition, but there had been no power to the ritual. Jack had to agree. It was this type of mechanical approach to ritual on the mundane level that Taylor abhorred. He tried to make all those he taught look deeper into themselves.

Although learning about ritual magic from books such as this

leaves a lot to be desired, it is often the only way to learn the subject, especially when a teacher is not available. This book is a tool, and a helpful guide based on the observations of a number of Adepts from the Golden Dawn, the Stella Matutina, and the Smaragdum Thalasses. It has been designed to make you aware of certain areas of importance in ritual. But only your own training and practice will make some of the things described here happen.

We have chosen the Neophyte Ceremony for the first of our books on ritual, because it is the essence of the Z.2 rituals from which all of the Second Order Rituals are based. To understand and perform the Z.2 correctly, one must know the higher functions of the Neophyte Ceremony.

Within the Golden Dawn teachings, within the "word of mouth" category, is the continual reference to magnetic manipulation of the aura. This starts at the Neophyte grade and continues through the 7=4 grade. Some of the "word of mouth" techniques, taught to us by Taylor, go back to the old Golden Dawn. However, we have taken the liberty of expanding them somewhat in this book. Eliphas Levi says in his *Transcendental Magic*.

When the magus has attained lucidity, whether through the mediation of a pythoness or by his own development, he communicates and directs at will the magnetic vibrations in the whole mass of the Astral Light, the currents of which he divines by means of the Magic Wand, which is a perfected divining rod. By the aid of these vibrations he influences the nervous system of persons made subject to his action, accelerates or suspends the currents of life, soothes or tortures, heals or hurts—in fine, slays or brings to life....

This is possibly an oversimplification. However, it is a highly accurate statement of the actions of ritual magic and the actions of the Hierophant and his Scepter during a ceremony such as that of the Neophyte. Just by studying the magnetic actions alone, one enters a labyrinth world of magnetism that has many layers. Some of these we hope to discuss in this book.

Over twenty years ago, I studied Tantra under the late Vivandatta. He made me aware of the use of the auric energies of the body.

He used his own aura to magnetically increase his body's vibrational pitch and thus sensitize it to certain etheric fields. This is where teachers like Taylor, who have the same ability as Vivandatta to control their aura, could teach at their best. They would not only tell you, they would show you. Taylor had the ability to take you out of your own physical body and introduce you to the magnetic currents in the ritual, one level at a time. The experience has to be undergone to be believed. But in doing this, he demonstrated a power that I have never perceived in any other magician before. He was truly awesome in this field, something which went against his frail body which was confined to a wheelchair in his twilight years.

When doing ritual, there is no substitute for practice. At Whare Ra, whenever possible, ritual practice was done once a week. Some temples train just once a month with only the officers conducting the ceremony attending. We would suggest that once a week be the average, with as many people as will fit into the Hall. Have those present take notes on their impressions of the movements, errors, and so on. This keeps everyone alert during the proceedings. The mechanics can be quickly learned this way. Furthermore, it leaves the way free for everyone to concentrate on the inner mechanisms. It is no good saying after the ritual that "it was really powerful this time." Rather, everyone must be able to dissect it and say why it was powerful or why the power was lacking. Ritual training is very hard work, make no mistake about it. People get quickly bored if they are half-hearted about it.

In this book there are a number of old concepts that have never been publicly revealed before and many new ones that we have developed. We hope that, over the years, others will benefit from our experiences and eventually improve on our meager notes. We are fast approaching an age where instruments, whether electronic, radionic, or a combination of both, will be able to categorize precisely the various energy levels during different parts of the ritual. The future adept may be able to use these, like biofeedback principles, to improve his or her performance. Until then, there is still a lot of hard work ahead of us. For those of you who may wish to study the magnetic theory from the scientific viewpoint of radionics, we would suggest reading David V. Tansley's book, *Radionics*

Interface with the Ether Fields, especially the chapter on the "Geometric Etheric Link."

This book has been divided into two parts. Part one gives the 0=0 ritual, which is taken from one of Whare Ra's earliest documents. It was written around 1912. When Whare Ra withdrew from the Stella Matutina in 1933, the rituals then simply crossed out the words "Stella Matutina" and inserted "Smaragdum Thalasses." This copy belonged to a former Chief of that Temple, Mason Chambers. He was one of the three Chiefs that Felkin left in charge, when he returned to England after his initial visit to New Zealand. When compared to previously published versions of the ritual, by Regardie, Torrens, and Gilbert, one will find, in some instances, additional material on the pivots, turns, etc., but also there are some areas lacking. There is an Alternate Adoration, given here, which was left up to the discretion of the Hierophant to use. In addition, more information is provided on the ceremony of the Eucharist, at the end of the ceremony, which has not been published before.

Overall, it would be a fair comment to say that the Stella Matutina versions of the Neophyte Rituals are far more descriptive than the early Golden Dawn ones that have been examined. A comparison with the published versions of both Torrens and Regardie will bear this out. The reason for this is unclear. It is possible they were re-edited by a group of Adepti under the Morgan Rothe (M.R.), the name for the Order between 1900 and 1903. "Morgan Rothe" is a Germanic name which loosely translates as "Red Dawn."

There are a number of other possibilities for the discrepancies in the versions. Perhaps the papers were re-edited later by the Stella Matutina, or the temple copies from the original master copies of Mathers were condensed to save additional writing.

Another version of the Neophyte Ceremony, written three years after the original breakup of the Order in 1900, is published by R.A. Gilbert in his *Golden Dawn: Twilight of the Magicians*. This is, in some respects, closer to, though not identical with, the New Zealand version published here.

Part two gives the explanation in a step-by-step easy-to-follow format. The whole book is designed to show the type of procedure a person encounters when joining a Golden Dawn Temple.

On a final note, there are a number of purists who go against any tampering with the Golden Dawn rituals. In the past, some of this tampering has been inferior and deserved critics. In other areas, such as the Consecration Rituals of the Elemental Weapons, the changes made by the Stella Matutina, in the Hermes Temple at Bristol, were superior to the original Golden Dawn documents. This is a point that most Golden Dawn aspirants will agree on, though each case must be presented on its own merits.

Some years ago, I had a discussion with a high-ranking member of the Order who took great pains to point out the "absolute correctness of the Consecration of the Vault Ceremony" after I suggested a change to it without telling this person what the change was. After some deliberation, this person was rather red-faced when informed that the consecration of Fire and Water was done in the reverse manner to what it should be, a basic error of some importance in a very important ceremony. Perfection in ritual is a goal to be strived for, and to do this one must be constantly trying to improve on the old to make it better where possible. But change in this area must be made for all the right reasons, and not for change's sake alone. The Golden Dawn is no exception. Some may consider that we have complicated an already complex system. For example, in our own case, when we were first introduced to many of the "word of mouth" teachings, we had our fair share of headaches trying to fathom out the intricacy of Golden Dawn ritual work. On more than one occasion, we wondered whether this was all necessary. Taylor put this to us very simply:

If you do not understand the deeper meaning of ritual, whether it be Golden Dawn or otherwise, then all you are doing is marking time and not growing in this area. The human soul and its connection to ritual is more complex than we have even dreamed about and, if you want to get to the kernel of this, then you will have to work long and hard. Even though I am now 87, and have been doing Golden Dawn ritual work for nearly 60 years, I still learn more every time I read or study the rituals. My own teacher told me years ago to make the complex second nature and then will you start to understand the deeper meaning of ritual.

We in New Zealand have not tried to set ourselves up as the last word on Golden Dawn ritual teachings. But we have tried, in our own way, to present some of the information we have learned to Golden Dawn enthusiasts. This needed to be done, for Whare Ra lasted the longest of the Golden Dawn temples. If we had waited for some elderly members of the Hermes-Bristol Temple to break their quarter of a century of silence and publish a volume such as this, I feel we should have a long wait.

If there are Golden Dawn Temples like our Thoth-Hermes that are there by "Apostolic Succession" and have the training and knowledge to pass on information and are reticent through their Obligation, then I make no apology for this work because they have preferred to keep the information to themselves at the expense of others who wish to learn. Personally, I find this type of attitude intolerable, especially in this day and age. To my mind, this is taking a step back to the dark ages of occultism. This information, which is slowly but surely making its way to the general public, is becoming an almost unstoppable tide. It is quite obvious to many that this is the way in which the Golden Dawn can be brought into the 21st century.

—Pat Zalewski
Wellington, New Zealand

Part 1
The Ritual

The Neophyte Ritual of Whare Ra Temple

*0=0 Grade of the First Order of the
Stella Matutina*

Officers

Imperator, Praemonstrator, Cancellarius

Hierophant—red robe, lamen, crown-headed scepter. Hiererus —
black robe, lamen, sword.

Hegemon —white robe, lamen, mitre-headed scepter. Kerux
—lamen, lamp, wand.

Stolistes —lamen, cup of lustral water.

DadoUchos —lamen, thurbile.

Sentinel —lamen, sword.

Requirements

Red rose, cross, triangle, chalice, paten, salt, bread, lamp, hoodwink,
sample sash, chemical change, and roll of membership.

O p e n i n g

When members are assembled and clothed, Hierophant gives one

knock. Kerux (Kerukains) goes to right of Hierophant, faces West, elevates wand and says:-

Kerux: Hekas, Hekas, Este Bebeloi.

Kerux returns to his place by East and South, giving the Grade Sign as he passes the Throne of the East. (N.B.: In all movements of officers and members the course of the Sun—a clockwise direction—must be followed, except in reverse circumambulation, though it may not invariably be necessary to pass immediately in front of Hierophant; but, when this latter is done, the Grade Salute must be given, as also when well within the Portal on entering or leaving the Hall. The Grade sign must be made in the direction of movement—clockwise, except when entering or leaving the Hall, when it is made towards the Hierophant.)

Hierophant rises with one knock.

Hiero: *Fratres and Sorores of the Order of the Stella Matutina, assist me to open the Hall of the Neophytes.*

All rise.

Frater Kerux, see that the Hall is properly guarded.

Kerux ascertains that the Hall is properly guarded by giving one knock—or he unlocks the door, looks out, then recloses and relocks the door. Sentinel replies by giving one knock with the hilt of his sword. (This applies also to closing.) If Sentinel is not present, Kerux gives one knock in reply to himself.

Kerux: *Very Honored Hierophant, the Hall is properly guarded.*

Hiero: *Honored Hieres, guard the hither side of the Portal and assure yourself that all present have beheld the Morning Star.*

Hieres passes to the door, stands in front of it with sword, Kerux at his right hand with lamp and wand.

Hieres: *Fratres and Sorores of the Order of the Stella Matutina, give the Signs of the Neophyte.*

Done. Hiereus gives Signs.

Very Honored Hierophant, all present have been so honored. Hiereus returns to his place. The Hierophant repeats the Signs.

Hiero: Let the number of Officers of the Grade and the nature of their offices be proclaimed once again, that the powers whose images they are may be re-awakened in the spheres of those now present and in the sphere of this Order, for by names and images are all powers awakened and re-awakened.

Gives Sign of Silence.

Honored Hiereus, how many Chief Officers are there in this Grade?

Hiereus: There are three Chief Officers: the Hierophant, Hiereus, and Hegemon. (Hierophantia, Hiereia, and Hegemone, if they are feminine.)

Hiero: Is there any peculiarity in these Names? Hiereus: They all commence with the letter 'H.' Hiero: And of what is this Letter a symbol?

Hiereus: Of Life, because the letter 'H' is our mode of representing the ancient Greek aspirate or breathing, and Breath is evidence of Life.

Hiero: How many lesser Officers are there?

Hiereus: There are three besides the Sentinel: Kerux (Kerukaina), Stolistes (Stolistria), and Dadouchos (Dadouche). The Sentinel guards the Portal of the Hall and has a sword in his hand to keep out intruders. It is his duty to prepare the Candidate.

Hiero: Frater Dadouchos, your station and duties?

Dadouchos: My station is in the South to symbolize Heat and Dryness, and my duty is to see that the Lamp and Fires of the Temple are ready at the Opening, and to watch over the Censer and Incense, and to consecrate the Hall and the

Fratres and Sorores and the Candidate with Fire. Hiero:

Frater Stolistes, your station and duties?

Stolistes: My station is in the North, to symbolize Cold and Moisture, and my duties are to see that the Robes and Collars and Insignia of the Officers are ready at the Opening, and to watch over the Cup of Lustral Water and to purify the Hall and the Fratres and Sorores and the Candidate with Water.

Hiero: Frater Kerux, your station and duties?

Kerux: My station is within the Portal; my duties are to see that the furniture of the Hall is properly arranged at the Opening, and to guard the inner side of the Portal, to admit Fratres and Sorores, and to watch over the reception of the Candidate, and to lead all mystic Circumambulations, carry the Lamp of my Office, and to make all reports and announcements. My Lamp is a symbol of the Hidden Knowledge and my Wand is a symbol of its directing power.

Hiero: Honored Hegemon, your station and duties?

Hegemon: My station is between the Two Pillars of Hermes and Solomon, and my face is towards the Cubical Altar of the Universe. My duty is to watch over the Gateway of the Hidden Knowledge, for I am the Reconciler between Light and Darkness. I watch over the reception of the Candidate and his preparation, and I lead him in the Path that conducts from Darkness to Light. The White Color of my robe is the color of Purity, my ensign of office is a Mitre-headed scepter to symbolize religion which guides and regulates life, and my Office symbolizes those higher Aspirations of the Soul which should guide its actions.

Hiero: Honored Hiereus, your station and duties?

Hiereus: My station is on the Throne of the West and is a symbol of increase of Darkness and decrease of Light, and I am the Master of Darkness. I keep the Gateway of the West and watch over the reception of the Candidate and over lesser

Officers in the doing of their work. My black Robe is an image of the darkness that was upon the face of the Waters. I carry the sword of Judgment and the banner of the Evening Twilight, which is the Banner of the West, and I am called Fortitude by the Unhappy.

Hiero: *My station is on the Throne of the East in the place where the Sun rises, and I am Master of the Hall, governing it according to the Laws of the Order, as HE whose image I am, is the Master of all who work for the Hidden Knowledge. My robe is red because of Uncreated Fire and Created Fire, and I hold the Scepter of Power and the Banner of the Morning Light, which is the Banner of the East. I am called Power and Mercy and Light and Abundance, and I am the Expounder of the Mysteries.*

Frater Stolistes, I command you to purify the Hall and members with Water.

Stolistes goes to the East and faces Hierophant, salutes, and makes a cross with Cup and sprinkles thrice with first and second fingers and thumb of right hand. Passes to South, West, and North, facing each point as he repeats cross and sprinkling, completes circle by returning to East where he faces East and says:—

I purify with Water.

Salutes Throne and returns to place by South and West.

Hiero: *Frater Dadouchos, I command you to consecrate the Hall and members with Fire.*

Dadouchos passes by West and North to East, faces Hierophant, salutes, holds thurible chain short and makes a cross, then lengthens the chain and censes with three forward swings, passes South, West, and North, facing each point, making a cross and three swings, completes circle by returning East, faces Hierophant and raises the thurible on high saying:—

I consecrate with Fire.

Salutes Throne and returns to place direct. Kerux goes to North, near Stolistes, facing East.

Hiero: *Let the Mystic Circumambulation take place in the Pathway of MGM'.*

In the following order. Hegemon, Hiercus, Members, Stolistes, Dadouchos, Kerux, and Sentinel last. In forming procession, Kerux passes to North, halts; Hegemon passes by South and West where he is joined by Hiercus, carrying the Banner of the West in his left hand and sword in his right; they pass on, Hegemon in front of Hiercus, and take their places behind Kerux; Dadouchos follows Hegemon from South, joining Stolistes; members from up behind Hiercus, Stolistes being on the left of Dadouchos (If too many members, officers only go around). As each passes Banner of East, he salutes in the Direction of progress. Hiercus passes Hierophant once, Hegemon twice, and the rest three times, and then all return to places. Hierophant stands with Banner of the East in his left hand and his scepter in his right.

Hiero: *The Mystical Circumambulation symbolical of the rise of LIGHT is accomplished. Let us adore the Lord of the Universe and Spaces.*

All turn East and salute, repeating the salute at each adoration, then give the Sign of Silence. Remain bent over until final Sign.

Hiero: *Holy are Thou, Lord of the Universe!* (Salute)

Holy are Thou, Whom Nature hath not formed! (Salute) *Holy are Thou, the Vast and the Mighty One!* (Salute) *Lord of the Light and of the Darkness!*

(Salute with Sign of Silence)

All officers raise Banners, Scepters, etc., on high then sink them in salutation.

Hiero: *Frater Kerux, in the name of the Lord of the Universe, who works in Silence, whom naught but Silence can express, I command you to declare that I have opened the Hall of the*

Neophytes.

Kerux passes Northeast in front of Hierophanes Throne, faces West, and raises his wand.

Kerux: In the name of the Lord of the Universe, Who works in Silence and Whom naught but Silence can express, I declare that the Day Star has arisen and the Shadows flee away.

Hiero: (knocks)

Hiereus: (knocks)

Hegemon: (knocks)

Hiero: (knocks) *KHABS.*

Hiereus: (knocks) *AM.*

Hegemon: (knocks) *PEKHT.* Hiererus:

(knocks) *KONX.*

Hegemon: (knocks) *OM.*

Hiero: (knocks) *PAX.*

Hegemon: (knocks) *LIGHT.* Hiero: (knocks)

IN.

Hiereus: (knocks) *EXTENSION.*

All make Signs and resume seats.

Kerux removes Rose, Lamp, Chalice, and paten from Altar. Minutes of the last meeting read and confirmed, Work of the Grade gone through, resolutions passed, etc.

Ceremony of Admission

The Candidate is not to be told the name of the Order of the Stella Matutina until his admission.

Hiero: Fratres et Sorores of the Order of the Stella Matutina, I have received a Dispensation from the greatly Honored Chiefs of the Second Order, to admit _____ to the 0=0

Grade of Neophyte. Honored Hegemon, bid the Candidate prepare for the Ceremony of his admission, and superintend his preparation.

Hegemon rises, removes chair from between the Pillars, and going without the Portal sees that Sentinel hoodwinks candidate and binds a rope three times round his waist. Hegemon takes the candidate by his right hand with his own left and causes him to knock.

Kerux: The Candidate seeks for entrance. (turns down lights)

Hiero: I give permission to admit, who now loses his name and will be henceforth known among us as. Let the Stolistes and the Dadouchos assist the Kerux in his reception.

Candidate is now inside the Portal.

Hegemon: Inheritor of a Dying World (or, Child of Earth; or, ye Earth-born folk), arise and enter the Darkness.

Stolistes: The Mother of Darkness hath blinded him with her Hair.

Dadouchos: The Father of darkness hath hidden him under His wings.

Hiero: His limbs are still weary from the wars which were in Heaven.

Kerux: Unconsecrated and Unpurified, thou cans't not enter our Sacred Hall.

Stolistes marks forehead with a cross and sprinkles thrice. Stolistes:

I purify thee with Water.

Dadouchos makes a cross and censes thrice.

Dadouchos: I consecrate thee with Fire.

Should there be more than one Candidate, Stolistes and Dadouchos must consecrate each alternately, so as to complete one before going to the next. Stolistes and Dadouchos resume

places, going clockwise but remaining standing_

Hiero: *Conduct the Candidate to the foot of the Altar.*

Inheritor of a Dying World, why seekest thou to enter our Sacred Hall? Why seekest thou admission to our Order?

Hegemon: (for Candidate) *My Soul wanders in Darkness and seeks the Light of the Hidden Knowledge, and I believe that in this Order, the Knowledge of that ancient Light may be obtained.*

Hiero: *We hold your written pledge to keep secret everything that relates to this Order. To confirm it, I now ask you, are you willing to take the solemn Obligation in the presence of this Assembly, to keep the secrets and Mysteries of our Order inviolate? There is nothing incompatible with your civil, moral, or religious duties in this Obligation. Although the Magical virtues can indeed awaken into momentary Life in the wicked and foolish hearts, they cannot reign in any heart that has not the natural virtues to be their throne. He who is the Fountain of the Spirit of Man and of Things, came not to break, but to fulfill the Law. Are you ready to take this Oath?*

Candidate: *I am ready.*

Hiereus, Hierophant, and Hegemon take their places in the form of a triangle around the Altar, Hierophant, from the East, advancing between the Pillars with scepter. Hiereus, North-West of Altar with sword. Hegemon, Southwest of Altar with scepter. Dadouchos East of Hegemon, and Stolistes East of Hiereus. Candidate, West of Altar. All members stand.

Hiero: *Kneel on both your knees. Candidate is assisted.*

Give me your right hand which I place upon this Holy Symbol. Place your left hand in mine, bow your head, repeat your full name by which you are known on earth, and say after me:

I _____ in the Presence of the LORD of the Universe, Who

works in Silence and whom naught but Silence can express, and in this Hall of the Neophytes of the STELLA MATUTINA, regularly assembled under warrant from the Greatly Honored Chiefs of the Second Order, do of my own free will, hereby and hereon, most solemnly promise to keep secret this Order, its Name, the Names of its Members and the proceedings that take place at its meetings, from every person in the world who has not been initiated into it: nor will I discuss them with any member who has not the Password for the time being, or who has resigned, demitted, or been expelled.

I undertake to maintain a kindly and benevolent relation with all the Fratres and Sorores of this Order.

I solemnly promise to keep secret any information I may have gathered concerning this Order before taking this Oath.

I solemnly promise that any Ritual or lecture placed in my care or any cover containing them, shall bear the official label of this Order.

I will neither copy nor allow to be copied any manuscript, until I have obtained permission of the Second Order, lest our Secret Knowledge be revealed through my neglect.

I solemnly promise not to suffer myself to be placed in such a state of passivity, that any uninitiated person may cause me to lose control of my words or actions.

I solemnly promise to persevere with courage and determination in the labors of the Divine Science, even as I shall persevere with courage and determination through this Ceremony which is their Image—and I will not debase my mystical knowledge in the labor of Evil Magic at any time tried or under any temptation.

I swear upon this Holy Symbol to observe all these things without evasion, equivocation, or mental reservation, under the penalty of being expelled from this Order for my perjury and my offence, and furthermore submitting myself by my own consent to a Deadly Stream of Power, set in action by the Divine Guardians of this Order, Who, Living the Light of their Perfect Justice, can, as tradition and experience affirm,

strike the breaker of this Magical Obligation with death or palsy, or overwhelm him with misfortune. They journey as upon the Winds; they strike where no man strikes; they slay where no man slays.

Hiereus places sword on Candidate's neck.

As I bow my neck under the Sword of the Hiereus, so do I commit myself unto their hands for vengeance or reward. So help me my Mighty and Secret Soul, and the Father of my Soul Who works in Silence and Whom naught but Silence can express.

Hiero: *Rise now Neophyte of the 0=0 Grade of the Order of the Stella Matutina.*

Hierophant resumes Throne.

Honored Hegemon will you now place the Neophyte in the Northern part of the Hall—the place of Forgetfulness, Dumbness, and Necessity, and of the greatest symbolical Darkness.

Hegemon does so, facing Candidate to East.

Hiero: *The Voice of my Undying Soul and Secret Soul said unto me, "Let me enter the Path of Darkness and peradventure, there shall I find the Light. I am the only Being in the Abyss of Darkness; from an Abyss of Darkness came I forth ere my birth, from the Silence of a Primal Sleep. And the Voice of Ages said unto my Soul—"I am He who formulates in Darkness, the Light that shineth in Darkness, yet the Darkness comprehendeth it not."*

Let the Mystic Circumambulation take place in the Path of Darkness which leads unto the Light, with the Lamp of the Hidden Knowledge to guide us.

Dadouchos moves round by West to North and as soon as he has ranged himself on the right hand of the Stolistes, Kerux takes his place in front of Hegemon and Neophyte, and Kerux, Hegemon with Neophyte, Stolistes and Dadouchos pass round the Hall. At

their first passing, Hiereus gives one knock. At their second passing Hierophant gives one knock. After the second passing of Hierophant, as soon as they reach the South, Kerux turns and bars the way.

Kerux: *Unpurified and Unconsecrated, thou cannot enter the Path of the West!*

Stolistes and Dadouchos come forward and Stolistes marks a cross on the forehead and sprinkles thrice.

Stolistes: *I purify thee with Water.*

Dadouchos waves censer in the form of a cross and swings it thrice.

Dadouchos: *I consecrate thee with Fire.*

Stolistes and Dadouchos fall back to their places in the rear.

Hegemon: *Child of Earth (or Mortal born of Earth) twice purified and twice consecrated thou mayest approach the pathway of the West.*

Kerux leads procession to Throne of Hiereus, who threatens with Sword.

Hiereus: *Thou canst not pass by me, saith the Guardian of the West, unless thou can tell me my name.*

Hegemon: *Darkness is thy Name, thou Great One of the Paths of the Shades.*

Kerux lifts hoodwink for a moment.

Hiereus: *Fear is failure, so be thou without fear. For he that trembles at the Flame and at the Flood and at the Shadows of the Air, hath no part in GOD. Thou hast known me now, so pass thou on.*

Kerux replaces hoodwink, procession moves on past Hierophant, who gives one knock, and past Hiereus, who knocks again. Arriving at North, Kerux turns and bars the way.

Kerux: Unpurified and Unconsecrated, thou canst not enter the Pathway of the East.

Stolistes and Dadouchos consecrate as before.

Hegemon: Thrice purified and thrice consecrated, thou mayest approach the Gateway of the East.

Stolistes and Dadouchos retire to rear. Kerux leads procession to Hierophant, who rises and menaces with scepter.

Hiero: Thou canst not pass me, saith the Guardian of the East, unless thou canst tell me my name.

Hegemon: Light dawning in Darkness is thy Name, the Light of a Golden Day.

Kerux raises hoodwink for a moment.

Hiero: Unbalanced Power is the ebbing away of Life. Unbalanced Mercy is weakness and the fading out of the Will. Unbalanced Severity is cruelty and the barrenness of the mind. Thou hast known me now, so pass thou on to the cubical Altar of the Universe.

Kerux replaces hoodwink and leads procession to Altar. Hierophant leaves Throne and passes between Pillars with scepter in his right hand and Banner of East in his left. He stops either between the Pillars or halfway between them and the Altar, or else to the east of the Altar, saying, halting at each sentence:-

Hiero: I come in the Power of the Light; I come in the Light of Wisdom; I come in the Mercy of the Light; The Light has Healing in his Wings.

Hiereus takes his place North of the Altar; Hegemon South and Neophyte West. Kerux behind Neophyte, between him and the Throne of the West. Stolistes West of Hiereus and Dadouchos West of Hegemon. All officers and members kneel. Hierophant turns to Altar, standing, and says:—

Hiero: *Lord of the Universe—the Vast and Mighty One; Ruler of the Light and of the Darkness;*

We adore Thee and we invoke Thee;

Look with favor upon this Neophyte who kneeleth before Thee, and grant Thine aid unto the higher aspirations of his (her) Soul, so that he (she) may prove a true and faithful Frater (Soror) Neophyte among us; to the glory of Thine Ineffable Name. Amen!

Alternate Invocation

Oh Thou Whom nature hath not Formed;

Oh Thou Who didst in reason Constitute the things that are; Oh Thou Whom nought but Silence can Express;

Look with favor upon this Neophyte; grant that he may labor in high things. Accept the pure offering of his reason from heart and soul stretched up to Thee. Let him become a faithful Frater (Soror) among us to Thy glory and to the glory of Thy Hierarchies. Amen!

All rise and remain standing. Neophyte is assisted to rise. Hierophant comes close to Altar and raises his scepter above Neophyte's head. Hiererus raises sword so as to touch Hierophant's scepter. Hegemon raises his scepter to others. Kerux then removes hoodwink at the word "light."

Hiero: *Inheritor of a Dying World, we call thee to the Living Beauty.*

Hiererus: *Wanderer in Wild Darkness, we call thee to the Gentle Light."*

Sentinel turns up Lights.

Hiero: *Long has thou dwelt in Darkness—Quit the Night and seek the Day.*

All: *We receive thee into the Order of the Stella Matutina.* Hiero:

(knocks) *KHABS.*

Hiererus: (knocks) *AM.*

Hegemon: (knocks) *PEKHT*.

Hiereus: (knocks) *KONX*.

Hegemon: (knocks) *OM*.

Hiero: (knocks) *PAX*.

Hegemon: (knocks) *LIGHT*.

Hiero: (knocks) *IN*.

Hiereus: (knocks) *EXTENSION*.

Officers remove scepters and sword from head of Neophyte. Kerux goes Northeast, raising lamp on high.

Hiero: (points to Kerux) *In all thy wandering in Darkness, the Lamp of the Kerux went before thee, though it was not seen by thine eyes. It is a symbol of the Light of the Hidden Knowledge. Let the Neophyte be led to the East of the Altar.*

Hegemon leads Neophyte to the North and East, placing him between the Pillars.

Hiero: *Honored Hiereus, give the Secret Sign, Token and Words, together with the present Password of the 0=0 Grade of the Stella Matutina. Place him (her) between the Mystic Pillars and superintend his (her) fourth and final Consecration.*

Hiereus passes by North to Black Pillar and stands on East side of it, facing Neophyte. Hegemon takes up similar position by White Pillar. Hiereus gives sword and banner to Hegemon and then stands in front of and facing Neophyte, passing between Pillars to do so.

Hiereus: *Frater (Soror) , I shall now proceed to instruct you in the secret Signs, grip and Words of this Grade. Firstly, advance thy left foot a pace as if entering a portal. This is the Step.*

The Signs are two. The First or Saluting Sign is given thus: lean forward and stretch out both arms thus: It alludes to your condition in a state of darkness groping for Light. The

second Sign is the Sign of Silence, and is given by placing the left forefinger on your lip thus: Left forefinger upon lower lip. It is the position shown in many ancient statues of Harpocrates and it alludes to the strict silence you have sworn to maintain concerning everything connected with this Order. The first sign is always answered by the second.

The Grip or Token is given thus: advance your left foot touching mine, toe and heel, extend your right hand to grasp mine, fail, try again, and then succeed in touching the fingers only. It alludes to the seeking guidance in Darkness.

The Grand Word is Har-Par-Krat, and is whispered in this position mouth to ear, in syllables. It is the Egyptian name for the God of Silence, and should always remind you of the strict silence you have sworn to maintain.

The Password is . It is periodically changed each Equinox so that a Member who has resigned, demitted, or been expelled may be ignorant of the existing Password. I now place you between the two Pillars of Hermes and Solomon in the symbolic gateway of Occult Wisdom.

Hiereus takes Neophyte by hands and draws him forward until he is between the Pillars. He takes back sword and banner from Hegemon, returns to his position North of and close to the Black Pillar, and says:-

Hiereus: *Let the final Consecration take place.*

Kerux goes to the North and remains there until the procession is formed. Stolistes and Dadouchos purify and consecrate the Hall as in the Opening, but at the end, instead of facing the Hierophant and raising the cup and censer on high, each salutes the Hierophant and then turns and consecrates Neophyte as previously.

Stolistes: *I purify thee with Water.* Dadouchos: *I consecrate thee with Fire.*

Hiero: *Honored Hegemon, I command you to remove the Rope, last remaining symbol of the Path of Darkness, and to invest our*

Frater (Soror) with the badge of this degree.

Hegemon passes from behind the White Pillar, hands scepter to Hiercus, removes rope, and invests Neophyte.

Hegemon: *By command of the Very Honored Hierophant, I invest you with the Badge of this degree. It symbolizes Light dawning in Darkness.*

Hegemon returns to White Pillar.

Hiero: *Let the Mystic Circumambulation take place in the Pathway of Light.*

Hierophant stands as in Opening, Hegemon in front and leading Neophyte, behind Kerux, Hiercus and then members and finally Dadouchos and Stolistes. All salute when passing Hierophant. Hiercus drops out when procession reaches his throne. Hegemon passes twice and the rest three times. When they reach a spot Northwest of the Station of Stolistes, Kerux and Neophyte halt.

Hiero: *Take your station Northwest of the Stolistes.*

Kerux motions Neophyte to seat, passing to a place between Pillars and Altar. Hegemon replaces his chair and sits down. Kerux replaces elements on Altar, returning to place (clockwise). All are seated.

Hiero: *The Threefold Cord bound about your waist was the image of the threefold bondage of mortality, which amongst the uninitiated is termed earthly or Material inclination, that has bound into a narrow place the once far-wandering Soul; and the Hoodwink was an image of the darkness, of Ignorance, of Mortality that has blinded men to the happiness and Beauty their eyes once looked upon.*

The Double Cubical Altar in the center of the Hall is an emblem of visible Nature or the Material Universe, concealing within herself the mysteries of all dimensions, while revealing her surface to the exterior senses. It is a double cube because, as the Emerald Tablet has said, "The things that are below are a reflection of the things that are above." The world

of men and women created to unhappiness is a reflection of the World of Divine Beings created to Happiness. It is described in the SEPHER YETSIRAH or Book of Formation as "An Abyss of Height" and as an "Abyss of Depth," "An Abyss of the East" and "An Abyss of the West," "An Abyss of the North" and "An Abyss of the South." The Altar is black because, unlike Divine Beings who unfold in the Element of Light, the Fires of Created Beings arise from Darkness and Obscurity.

On the Altar is a White Triangle to be in the image of that Immortal Light, the Triune Light, which moved in darkness and formed the World out of Darkness. There are two contending Forces and one always uniting them. And these Three have their Image in the Threefold Flame of our Being and in the threefold wave of the sensual world.

Hierophant stands in the form of a cross, holding Banner of East.

Glory be to Thee, Father of the undying. For Thy Glory flows out rejoicing to the ends of the Earth.

Reseats himself.

The Red Cross above the White Triangle is an image of Him Who was unfolded in the Light. At its East, South, West, and North Angles are a Rose, Fire, Cup of Wine, and Bread and Salt. These allude to the Four Elements, Air, Fire, Water, Earth. The Mystical Words—KHABS AM PEKEIT—are ancient Egyptian, and are the origin of the Greek "KONX OM PAX," which was uttered at the Eleusinian Mysteries. A literal translation would be "Light Rushing Out in One Ray" and they signify the same form of Light as that symbolized by the Staff of the Kerux.

East of the Double Cubical Altar of created things are the Pillars of Hermes and Solomon. On these are painted certain Hieroglyphics from the 17th and 125th Chapters of the Book of the Dead. They are the doorposts of the Gateway of the Hidden Wisdom. They are the symbols of the twin powers of Day and Night, Love and Hate, Work and Rest, the subtle

force of the Lodestone and the Eternal out-pouring and in pouring of the Heart of God. The lamps that burn, though with a veiled light, upon their summits show that the Pathway to Hidden Knowledge, unlike the Pathway of Nature—which is a continual undulation, the winding hither and thither of the Serpent—is the straight and narrow way between them.

It was because of this that I passed between them, when you came to the Light, and it was because of this that you were placed between them to receive the Final Consecration. Two contending Forces and one which unites them eternally. Two Basal angles of the triangle and one which forms the apex. Such is the origin of Creation—it is the Triad of Life.

My Throne at the Gate of the East is the place of the Guardian of the Dawning Sun.

The Throne of Hiereus at the Gate of the West is the place of the Guardian against the Multitudes that sleep through the Light and awaken at the Twilight.

The Throne of the Hegemon seated between the Columns is the Place of Balanced Power, between the Ultimate Light and the Ultimate darkness. These meanings are shown in detail by our insignia and the color of our robes.

The Wand of the Kerux is the beam of Light from the Hidden Wisdom and his Lamp is an emblem of the ever-burning Lamp of the Guardian of the Mysteries.

The Seat of the Stolistes at the Gate of the North is the Place of the Guardian of the Cauldron and the Well of Water—of Cold and Moisture.

The Seat of the Dadouchos at the Gate of the South is the Place of the Guardian of the Lake of Fire and the Burning Bush.

Frater Kerux, I command you to declare that the Neophyte has been initiated into the Mysteries of the 0=0 Grade.

Kerux advances to right front of Hierophant, raises wand.

Kerux: In the name of the Lord of the Universe, Who works in Silence and Whom naught but Silence can express, and by

command of the Very Honored Hierophant, hear ye all, that I proclaim that, who will henceforth be known to you by the motto, has been duly admitted to the 0=0 Grade as a Neophyte of the Order of the Stella Matutina.

Kerux returns to place, saluting Hierophant.

Hiero: *Honored Hiereus, I delegate to you the duty of pronouncing a short address to our Frater on his admission.*

Hiereus: *Frater (Soror) , it is my duty to deliver this exhortation to you. Remember your Obligation in this Order to secrecy—for Strength is in Silence, and the seed of Wisdom is sown in Silence and grows in Darkness and Mystery.*

Remember that you hold all religions in reverence, for there is none but contains a Ray from the Ineffable Light that you are seeking. Remember the penalty that awaits the breaker of His Oath. Remember the Mystery that you have received, and that the Secret of Wisdom can be discerned only from the place of balanced Powers.

Study well the Great Arcanum of the proper equilibrium of Severity and Mercy, for either unbalanced is not good. Unbalanced Severity is cruelty and oppression; unbalanced Mercy is but weakness and would permit Evil to exist unchecked, thus making itself as it were, the accomplice of that Evil.

Remember that things Divine are not attained by mortals who understand the Body alone, for only those who are lightly armed can attain the summit.

Remember that God alone is our Light and the Bestower of Perfect Wisdom and that no mortal power can so more than bring you to the Pathway of that Wisdom, which he could, if it so pleased him, put into the heart of a child. For as the whole is greater than the part, so are we but Sparks from the Insupportable Light which is in Him.

The ends of the Earth are swept by the borders of his Garment of Flame—from him all things proceed, and unto Him all things return. Therefore, we invoke Him. Therefore

even the Banner of the East falls in adoration before Him.

Hiero: Before you can ask to pass to a higher Grade, you will have to commit certain rudiments of Occult Knowledge to memory. A manuscript lecture in these subjects will be supplied you by the Chief in whose charge they are. When you can pass an examination in this elementary Qabbalistic Knowledge, you will inform the Member in whose charge you are, and arrangements will be made for you to sit for examination. If you are found perfect, you will then apply for admission to the next Degree. Remember, that without a Dispensation from the Second Order, no person can be admitted or advanced to a Grade of the First Order.

Kerux conducts Neophyte to his table (going clockwise), gives him a solution, telling him to pour a few drops on the plate before him.

Kerux: Nature is harmonious in all her workings, and that which is above is as that which is below. Thus also, the Truths which by material Science we investigate, are but special examples of the all-pervading Laws of the Universe. So, within this pure and limpid fluid, lie hidden and unperceived of mortal eyes the elements bearing the semblance of blood, even as within the mind and brain of the initiate lie concealed the Divine Secrets of the Hidden Knowledge. Yet if the Oath be forgotten, and solemn pledge broken, then that which is secret shall be revealed, even as this pure fluid reveals the semblance of blood.

Kerux pours liquid into plate.

Let this remind thee forever, O Neophyte, how easily by a careless or unthinking word, thou mayest betray that which thou hast sworn to keep secret and mayest reveal the Hidden Knowledge imparted to thee, and implanted in thy brain and in thy mind. And let the hue of blood remind thee that if thou shalt fail in this thy oath of secrecy, thy blood may be poured out and thy body broken, for heavy is the penalty exacted by the Guardians of the Hidden Knowledge from those who

wilfully betray their trust.

Cancellarius superintends signing of the Roll.

Hiero: *Resume your seat, and remember that your admission to this Order gives you no right to initiate any other person without Dispensation from the Greatly Honored Chiefs of the Second Order.*

Closing

Hierophant, or any other member by his command, rises to enquire if anyone has anything to propose for the good of the Order for the first, second, and third time. Then may Hierophant address Neophyte.

Kerux passes to Northwest of Hierophant's throne, raising wand.

Kerux: *HEKAS! HEKAS! ESTE BEBELOI!*

Kerux then returns to place (going clockwise) Saluting Throne.

Hiero: *Fratres et Sorores of the Smaragdum Thallasses Temple of the Order of the Stella Matutina, assist me to close the Hall of the Neophyte.*

All rise.

Hiereus: (knocks)

Hegemon: (knocks)

Kerux: (knocks)

Sentinel: (knocks)

Hiero: *Frater Kerux, see that the Hall is properly guarded.*

Kerux: (knocks as in opening) *The Hall is properly guarded, Very Honored Hierophant.*

Hiero: *Honored Hiereus, assure yourself that all present have beheld the Stella Matutina.*

Hiereus: *Fratres et Sorores, give the Signs.*

Very Honored Hierophant, all present have been so honored.

Hiero: *Let the Hall be purified by Water and Fire.*

Stolistes: (purifies as in Opening) *I purify by Water.*

Dadouchos: (consecrates as in Opening) *I consecrate with Fire.*

Hiero: *Let the Mystical Reverse Circumambulation take place in the Pathway of Light.*

Kerux passes by West to South, Hegemon by North to West and South. Hiereus direct to South, then members. Stolistes by West to South on left of Dadouchos. Kerux leads, all saluting as they pass East—each time. Hiereus falls out when they pass his throne. Hegemon falls out when they pass his throne, Hegemon twice round, the rest three times.

Hiero: *The Mystical Reverse Circumambulation is accomplished. It is the symbol of Fading Light. Let us adore the Lord of the Universe.*

All turn East.

Hiero: *Holy art Thou, Lord of the Universe!* (all salute)

Holy are Thou, Whom nature hath not formed! (all salute) *Holy art Thou, the Vast and the Mighty One!* (all salute) *Lord of the Light, and of the Darkness!* (Sign of Silence) *All turn to center and salute as in Opening.*

Alternative Adoration

Holy art Thou, Father of Beings and of Spaces.

Holy art Thou, Who didst in reason constitute the things that are.

Holy art Thou, Whom nature hath not Formed.

Holy art Thou, Who workest in Silence and Whom nought but Silence can express.

(Repeat salute at each adoration)

Hiero: *Nothing now remains but to partake together in silence, of*

the Mystic Repast, composed of the symbols of the Four Elements, and to repeat our pledge of secrecy.

Kerux lights lamp on altar.

Hierophant quits Throne without scepter or Banner, goes West of Altar, faces East and gives Saluting Sign.

Hiero: *I invite you to inhale with me the perfume of this Rose, as a symbol of Air.*

To feel the warmth of this sacred Fire. (spreads hands over it)

To eat with me this Bread and Salt as types of Earth. (breaks and dips bread in salt and eats)

And finally to drink with me this Wine, the consecrated emblem of Elemental Water.

Drinks from cup after making a Sign of the Cross with it. All subsequently make Sign of Cross with cup before drinking. Hierophant passes to East of Altar (going clockwise) and administers Repast to senior Chief, raising and handling Elements. The saluting Sign (first part), is made by each towards the altar on coming forward, the celebrant replying with the Sign of Silence. The Chiefs in their order partake first, then the Officers (except Kerux), including Sentinel, from Hierous to Dadouchos.

Hiero: *Let all members below the grade of Portal be seated.*

All 5=6 members then communicate in the order in which they happen to be seated, beginning with the nearest to the left of Hierophant and working round South, West, and East. Each lifts and hands the Elements to the one who comes after him, returning to his place round the Altar (clockwise) and then sits down. When the last 5=6 member is East of Altar:-

Hiero: *Let all members of the 4=7 degree now rise.* (They rise and partake as before)

Let all members of the 3=8 degree now rise. (They rise and partake as before)

Let all members of the 2=9 degree now rise. (They rise and partake as before)

Let all members of the 1=10 degree now rise. (They rise and partake as before)

Let the Neophytes now rise.

They rise and partake as before; when the last Neophyte is at the Altar the Kerux steps up without insignia and partakes. When the cup is handed to him he finishes the wine and bread and, holding the Cup on high, turns it upside down, crying loudly:—

It is finished.

Kerux returns to his place. All rise.

Hiero: *TETELESTAL*

Hiero: (knocks)

Hiereus: (knocks)

Hegemon: (knocks)

Hiero: (knocks) *KHABS.*

Hiereus: (knocks) *AM.*

Hegemon: (knocks) *PEKHT.* Hiereus:

(knocks) *KONX.*

Hegemon: (knocks) *OM.*

Hiero: (knocks) *PAX.*

Hegemon: (knocks) *LIGHT.* Hiero: (knocks)

IN.

Hiereus: (knocks) *EXTENSION.* All make signs towards Altar.

Hiero: *May what we have partaken of sustain us in our search for the QUINTESSENCE, the Stone of the Philosophers, True*

Wisdom, Perfect Happiness, the SUMMUM BONUM.

All disrobe and disperse.

If the Hall is not reserved exclusively for Temple purposes, it should be purified by the lesser Ritual of the Pentagram being performed by the Hierophant with his scepter as soon as the members are assembled.

In case of the Hall not being duly oriented, the following prayer should be said by the Hierophant before the formal opening and after performance of the Lesser Ritual of the Pentagram. The Hierophant face the true East and between that point and the Altar says:—

Creator of the Universe, Lord of the Visible World, who hast by Thy Supreme Will set limits to its magnitude and conferred special attributes on its boundaries, we invoke Thee to grant that whatever hidden and mystic virtue cloth reside in the radiant East—the Dayspring of Light—the origin of Life—may in answer to this our prayer be this day conferred upon the Throne of the Hierophant of this Temple, who is the emblem of the Dawning of that Golden light which shall illuminate the Path of the Unknown and shall guide us at length to the attainment of the Quintessence, the Stone of the Wise, True Wisdom and Perfect Happiness.

Part 2
The Commentary

A Commentary on The Neophyte Ritual

Containing Z.1, Z.2, and Additional Material

Application to Join a Temple

The following is an example of a request to join a Golden Dawn Temple. All applicants are expected to sign and return the form (taken from an early Golden Dawn document) for consideration of their eligibility to join the Temple.

Some years since, permission was granted by the Secret Chiefs of the Order to certain Fratres learned in the Occult Sciences to direct the Working of the Esoteric Order of the G.:D.: in the Outer, with the view of aiding the study of Occultism and the mysteries of Life and Death; further also authorizing them to hold meetings both for the purposes of Study and also for the Initiation and Advancement of any person of either Sex, who should be accepted as a candidate by the Chiefs and who should be prepared and willing to take an Obligation of the most solemn character to maintain Absolute Secrecy regarding all things to the Order (such Obligation being nowise contrary to either their Civil, Moral, or Religious duties).

Belief in a Supreme Being, or Beings, is indispensable. In addition, the candidate, if not a Christian, should be at least prepared to take on an interest in Christian Symbolism.

The Chiefs of the Order do not care to accept as Candidates any persons accustomed to submitting] themselves as Medi-

ums to the Experiments of Hypnotism, Mesmerism, or Spiritualism; or who habitually allow themselves to fall into a completely passive condition of will; also they disapprove of the methods made use of as a rule in such Experiments.

This Order is not established for the benefit of those who desire merely a superficial knowledge of Occult Science:

Preliminary Pledge to be Signed by Intending Candidate

I the undersigned do hereby solemnly pledge myself:

- (1) That I am over the age of 21 years.
- (2) That I join this Order of my own free Will and accord.
- (3) To keep secret this Order, its Name, its members, and its Proceedings, from every person outside its pale; and even from Initiates unless in actual possession of the Pass-Word for the time being. I further promise to keep secret any information relative to this Order which may become known to me before my admission; and I also pledge myself to divulge nothing whatsoever to the outside World concerning this Order in case MI either my Resignation, Demission or Expulsion therefrom.
- (4) Undertake to prosecute with zeal the study of Occult Sciences.
- (5) If accepted as a candidate, I undertake to persevere through the Ceremony of Admission.

(Signature in Full) _____

Dated this _____ day of _____, 19

I select the following for my Motto: ___ (Latin is preferable)

I desire that communications may be addressed to me as under:

(Address in Full): _____

Acceptance of a Candidate

The acceptance of a Candidate for a Golden Dawn, A.O., or Stella Matutina varied to a certain degree. Wherever possible, the candidate was first interviewed by a panel of members. This was followed by an "Astral Investigation," which was performed by a clairvoyant member of the Temple. Usually, this person was one of the Chiefs, or a person sufficiently high enough in the Order and nominated by the Chiefs, to astrally investigate the candidate.

During the later years of the Stella Matutina, this practice fell into abeyance. A good documented example of this is shown in *The Sword of Wisdom*, where Ithell Colquhoun tried to become a

member of an A.O. temple (which I assume was in the early 1930s) under the Chieftainship of Mrs. Weir. A few nights after applying to join the temple, Colquhoun underwent an experience that she termed an "invasion" where she experienced an impersonal force coming into contact with her and which she termed the "Power of the Y." After this experience, she was refused membership to the A.O. Temple.

To most people who understand any type of psychic activity, this is relatively straightforward enough. Consider the psychic experiments allegedly undertaken by the C.I.A., where those that were psychic enough drew maps of secret missile installations in Russia. It would be fair comment to say that if one has the psychic ability, he or she can drop in and investigate anybody. The exception to this is a trained Adept who has the ability to recognize and neutralize this force (though we doubt the C.I.A. has studied this type of research). Colquhoun also mentioned that this force may have been the "Secret Chiefs" (as opposed to the elderly matrons who took the office of Chiefs at the time).

It has been our experience that not one but two types of psychic investigations can take place. The first, an investigation by an Order clairvoyant, cannot always be deemed accurate unless it is done by someone who has a proven ability in that field. The second is when people who have applied to join the Order experience the same symptoms quoted by Colquhoun. This must be done on an entirely involuntary basis. It has been described as a cloud or energy field descending on one. By "involuntary," we mean that it was not done on any conscious level by any temple officer. The latter form of investigation has been noted more than once at Whare Ra, and also by a number of initiates of our Thoth-Hermes Temple. Whether it is an effect of the "Secret Chiefs" or not, we cannot say; but, according to what we have seen, this type of investigation generally occurs to people who are deemed unqualified to advance far into the Order and, in the view of hindsight, would generally be considered unsuitable as Second Order material.

Most people may wonder why, if this type of examination of candidates was available, did the Golden Dawn undergo so much

turmoil? The answer is simple enough. This type of investigation can only be applied to the Outer Order (for reasons mentioned above) where people are not in a position to dictate terms to the Inner Order. Jack Taylor pointed out to us a number of cases at Whare Ra where some members were perfect Outer Order members and put all their efforts behind the Order. But once admitted to the Inner Order, things changed to the opposite. We know of one American Temple Chief, a trained psychologist, who uses her training and her ability to be able to read the horoscopes of prospective members to see if they are suitable before they are admitted. However, going on the track record of this temple, from those who have left it, this method is not any more successful than the astral examinations of the earlier temples.

Preparation of the Candidate

The preparation of the Candidate differed to a certain extent from temple to temple within the Golden Dawn, and later in the Stella Matutina. The following description is an example of what is undergone in the New Zealand Order.

Once it is decided that a Candidate is suitable for initiation by the Chiefs, the Hierophant then obtains a natal birth chart from the aspirant. From this, an electional chart is made up. The two are joined together so that a suitable time for the ritual can be worked out.

Once this is done, a temple member, or one of the temple officers of the oncoming ceremony, instructs the Candidate to:

(1) Fast at least four hours before the ritual. This is done to ensure an empty stomach, which makes the psychic channels more open and receptive to stimulation.

(2) Bathe in herbs of the lilacae family, which relate to Malkuth. These herbs penetrate the aura and leave a residue in it that makes it receptive to the auric manipulation which is conducted during the ceremony.

(3) Meditate on a suitable name for at least twenty minutes before the ceremony. Generally this form of meditation uses the Hebrew name of the Order (ChBRH ZRCh BQR AWR—Society of the Shining Light of Dawn), which the Candidate is told to repeat

continuously until s/he is blindfolded by the Sentinel. The theory behind this meditation is that constant repetition of the name, by the aspirant, helps break down the astral sheaths between him/herself and the Order.

Preparation of the Hall

The temple layout is shown in Figure 1. The first officer to enter the Hall before the ceremony is the Kerux, whose duties are to set up the temple furniture. This officer is followed by the Stolistes, who attends to the placing of the Holy Water and oversees that all robes and insignias are ready. (Temples like Whare Ra usually supplied the robes, but, in smaller temples, the individual officers generally had their own. Regardless, it is still the duty of the Stolistes to check with each member to be sure that everything is in order.) The Dadouchos is the last of the junior officers to enter the temple. It is his or her duty to attend to the lamps, censers, and candles.

Once all the physical temple props are in place, the officers vacate the temple about one hour before the start of the ceremony so that the Hierophant can enter. It is s/he who must create the astral shells of the various god-forms and energize them according to the temple floor plan, as shown in Figure 2. This is done with each god-form on an individual basis. It is extremely important that each astral shell be in its correct size, shape, and color. These are brought as close to the stage of manifestation as possible by the Hierophant. S/he will, through his/her own aura, know exactly how far to activate them. This would still be considered on a low vibrational scale. It is accomplished through the use of the DWB (Divine White Brilliance) or LVX formula, as it is sometimes called, which links together the Nephesh and the Ruach of the Hierophant. The shells of these god-forms are, at this point, linked to the Ruach of the Hierophant. They can be considered as a type of blind force at a low vibrational pitch. They are, in fact, not fully activated and could be described as the Nephesh of themselves.

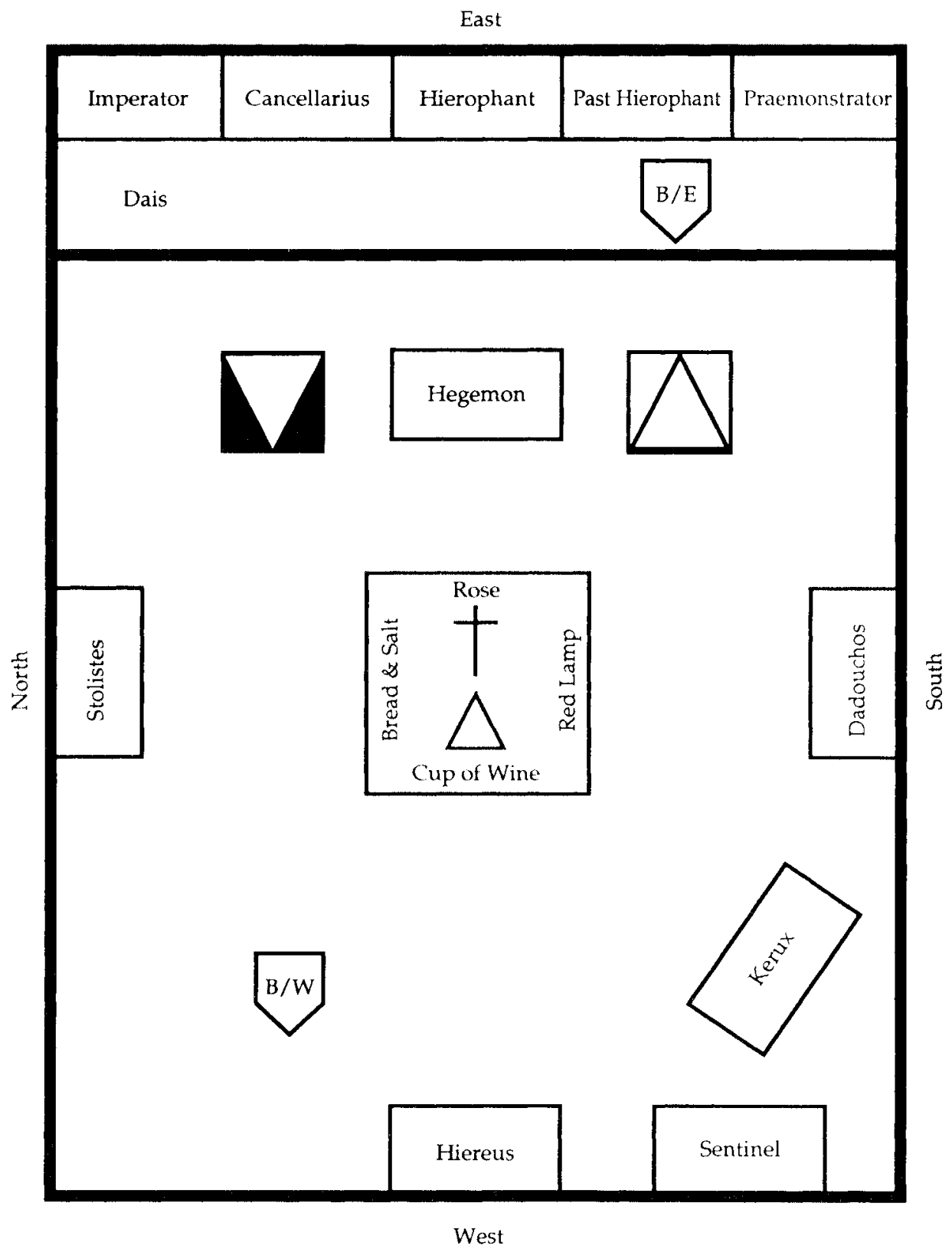

Figure 1
Temple Layout

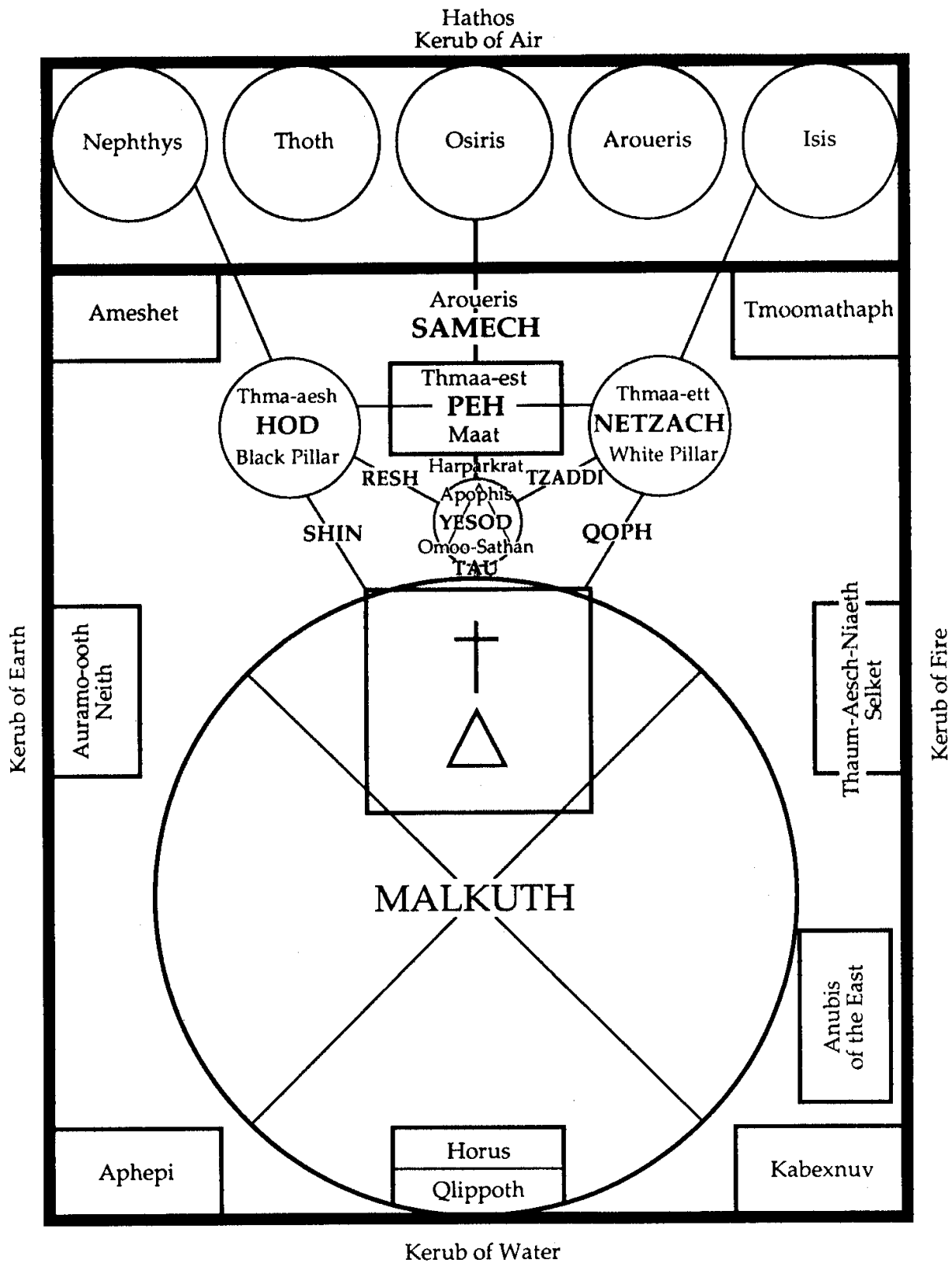

Figure 2
Temple Layout Showing Location of God-Forms

Within the Golden Dawn, the creation and utilization of these god-forms was done at a number of different levels, and for many different reasons. Their use in rituals like the O=O is mainly two-fold. The first is the building up of the god-form so that you can link your energy to it, so that you can draw from its power by complete identification and absorption of its qualities. An example of this is given by Israel Regardie in his Golden Dawn Ritual of Transformation. Within the O=O, another aspect is then approached with the formation of more than one god-form in the astral so that each force will counterbalance the other. The formula by which this is done is:

- (1) The Banishing Ritual of the Pentagram.
- (2) By AHIH (bring down the power) to the Tiphareth center where the names of the god-forms are formulated in white.
- (3) Vibratory formula of the name of each god-form—as many times as there are letters in their names .
- (4) Project the rose ray into the astral and then create them.

The colors of these temple god-forms are extremely important. While the power of the Ruach initially forms their Astral Shell, their flashing colors are needed to attract the power that the god-form represents. The Mathers papers on "Telesmatic Images" explains how this is done:

Now there is also a mode whereby, combining the letters, the colours, the attributions and their Synthesis, thou mayest build up a telesmatic Image of a Force. The Sigil shall then serve thee for the tracing of a Current which shall call into action a certain Elemental Force. And know thou that this is not to be done lightly for thine amusement or experiment, seeing that the Forces of Nature were not created to be thy plaything or toy. Unless thou doest thy practical magical works with solemnity, ceremony and reverence, thou shalt be like an infant playing with fire ...

Though this paper is related to telesmatic figures, the same fundamental principles of formulation in the astral still apply. The sigils referred to here are the ones traced from the rose cross (see Golden Dawn Flying Rolls 2 and 6 for correct use of this

method). [These documents can be found in *Astral Projection, Ritual Magic, and Alchemy*, edited by Francis King, Rochester, VT: Destiny Books, 1987. —Eds.]

In general the ray with the name projected from the Tiphareth center will perform much the same function. This whole procedure can be quite exhausting and is generally done from a paper, with names, colors, and sigils of the Invisible Stations used as a prompt. In his book *Energy, Prayer, and Relaxation*, Regardie says,

The ancient custom was to image the form of the God, a fairly common pictograph, and whilst uttering the prayer to feel that this god-form enveloped the body of the invoker.

This is, of course, another method of creating the astral shell of the god-form by the use of prayer. The first method, quoted above, was the one taught to Taylor, who was a stickler that one must always have the form on paper, in front of one, before the invocations are begun. Though Hierophants are expected to know every shape and position of a god-form by heart, the god-form formulation is generally done from a temple diagram so that no mistakes can be made.

The robes of the officers also play an important part. When the astral shells of the god-form are created, they are linked to the robes and badges of the officers who are placed in the positions they occupy around the Hall. Once the Hierophant has completed this task (which can take from 30 to 40 minutes to perform correctly) the Dadouchos is then brought back into the temple and performs the candle-lighting ceremony, watched by the (throned) Hierophant. It is important to remember that a candle is placed in the quarter it represents. The Yellow candle for the East, however, is placed between the pillars and slightly behind the chair of the Hegemon.

The ceremony of candle lighting is always started at the East, going in a clockwise spiral, until the final candle on the altar is lit. Two main things occur during this exercise. The first is that the Hierophant extends his/her Ruach to the fire of the Dadouchos. The second is that the aura of the Dadouchos gives the flame its

link which, controlled by the Hierophant, brings the first active element into the floor plan, for Fire is the first manifested element.

During this ceremony, the Hierophant must have the ability to "cradle the aura of the Dadouchos." By this I mean s/he must reach out and control the actions of the Dadouchos on the Astral through a process of auric manipulation. (This is later manipulated by the Hegemon.)

After this, the rest of the Temple officers are admitted. They go to their respective stations and await the Kerux, the final officer to enter the Hall, after s/he has attended to the Candidate.

At this point, we should mention that, in the Golden Dawn and the early stages of the Stella Matutina, the temple officers on the floor could be Outer Order Grades. However, the 78 additional years of ritual of the Stella Matutina have shown that the energy fields that these junior officers have to work with are much more complex than was first thought.

In the later years of the Stella Matutina and the Smaragdum Thalasses, here in New Zealand, it was thought that these floor officers should all be Inner Group members, where possible. Prior to his or her entrance to the Temple, all officers would sit quietly in order to link their Ruachs and Neshamahs (which under normal circumstances cannot be done by Outer Order members). Hence, their activated Spheres of Sensations (auras) then link into, and feed, the astral shells of the Invisible Stations created by the Hierophant. This also, to a certain extent, gives the Hierophant an element of control over the stations linked to each officer. S/he can, in fact, control the link by increasing, or decreasing, the vibrational pitch of the god-form, where there is an excess or decrease of energy. This can be brought about by the mood of the temple officer in order to balance things together in the overall floorplan.

When these officers take their positions and link their Ruachs with the Nepesch of the form created by the Hierophant, it is important that they have a correct mental image of the god-form they are assuming. This is, in fact, god-form assumption in a group format. The officers on the Dais also have a part to play in

this preparation. They usually enter, with the rest of the officers, after the candles are lit by the Dadouchos. Once seated on their respective Thrones, they also link their Wachs with the Nephesch shells created by the Hierophant. The following paper outlines the coloring and positioning of each of the astral shells that the Hierophant has to create around the temple before the start of the ceremony. It is more complete than previously published papers, in the sense that additional notes have been added to explain the reasons why some of the god-forms are colored the way they are.

The Egyptian God-Forms of the Neophyte Grade

The stations of the god-forms used in our symbolism come under two heads:

1. Visible Stations.

2. Invisible Stations.

The Visible Stations are the places of the officers, each of whom has a special astral shape suitable to the forces s/he represents. On the Dais are places for the Three Chiefs, the Past Hierophant, and the current Hierophant. The order in which they sit (as you face East, from left to right) is:

Imperator—Nepthys

Cancellarius—Thoth

Hierophant—Osiris

Past Hierophant—Aroueris

Praemonstrator—Isis

The names below are those of the god-forms they represent. The following are descriptions of the god-forms of the seven officers of the Neophyte Grade.

Hierophant: Osiris in the netherland. Expounder of the mysteries in the Hall of the Dual Manifestation of the Goddess of Truth. The Hierophant is represented by two god-forms, the passive and the active aspects of Osiris, as shown in Figures 3 and 4. Seated on the Dais, as Hierophant, he is clothed in the god-form of Osiris. As Osiris, he wears the tall White Crown of the South, flanked by feathers stripped white and blue. His face

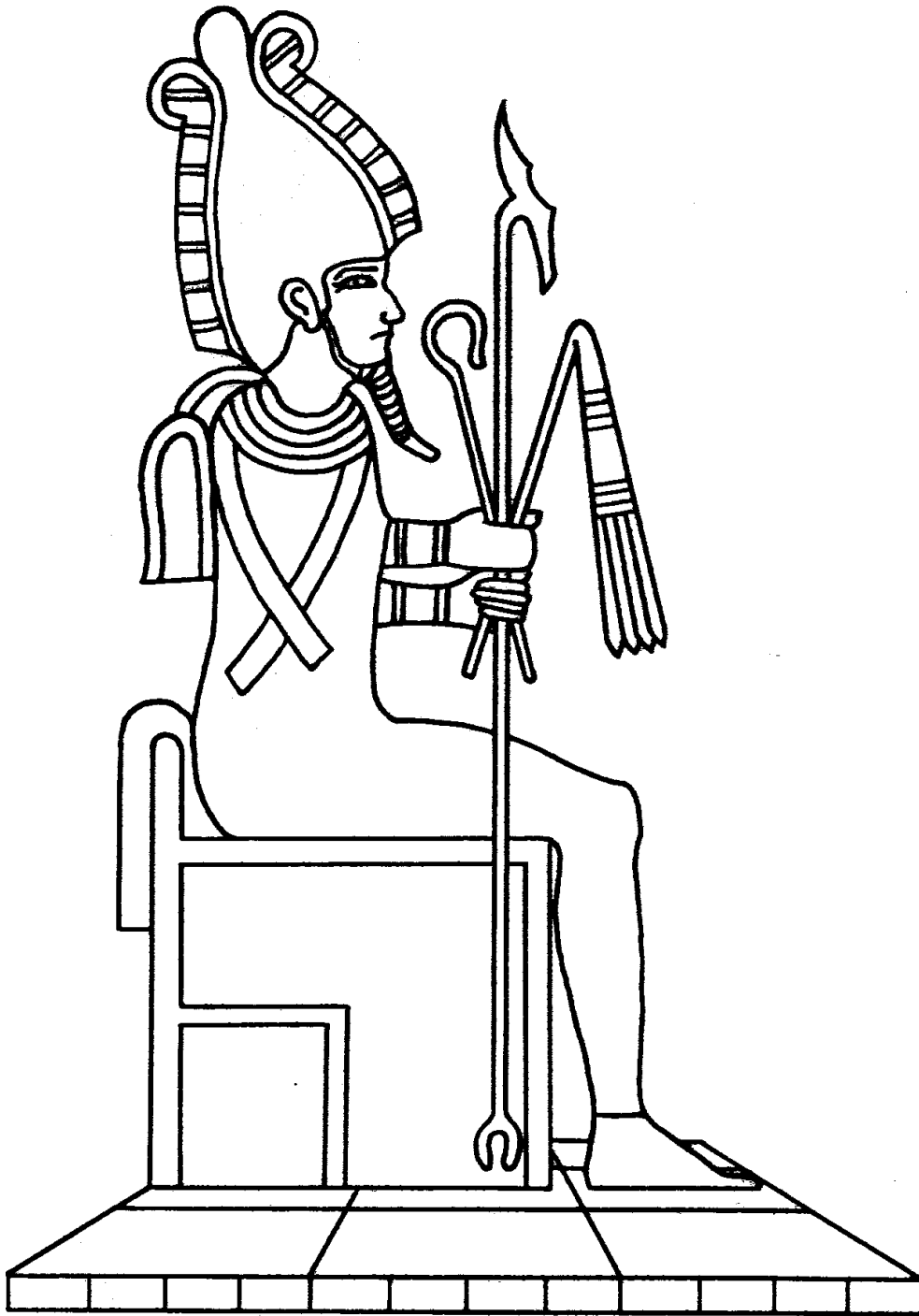

Figure 3
Osiris

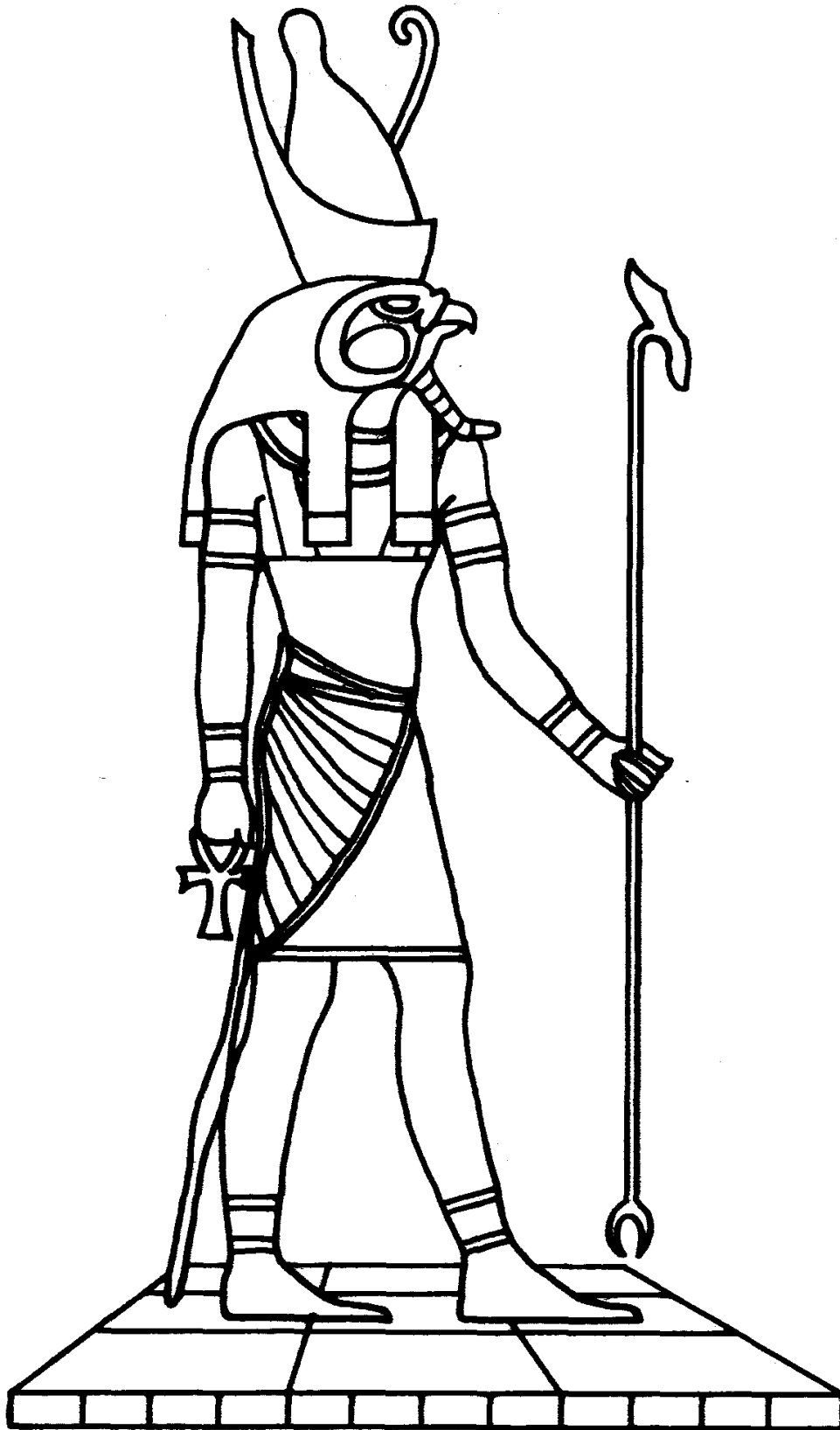

Figure 4
Aroueris

is green, his eyes blue. From his chin hangs the royal beard of authority and judgement, blue in color and gold tipped. He wears a collar in bands of red, blue, yellow, and black. On his back is a bundle, strapped across his chest by scarlet bands. He is in mummy wrappings to the feet. His hands are free to hold a golden Phoenix Wand, a Blue Crook, and Red Scourge. His hands are green. His feet rest on a pavement of black and white.

The colors used to construct this figure are a mixture of Golden Dawn teachings and the traditional colors of the figure. As an example, the blue and white crown and blue beard show both the influence of Kether and the Path of Samekh, while the yellow tip shows the Air element. The bands of his collar represent the four elements, while the scarlet bands across him allude to the Rosicrucian grade. The Phoenix Wand is traditional, while its golden color shows that it comes through Tiphareth. The green skin coloring is from the traditional coloring. The blue crook and red scourge shows that he holds together both the power of Geburah and Chesed.

Although no official paper was ever issued on the subject of the Egyptian god-form coloring, Jack Taylor said that Felkin's master copy, from the old Order, was often consulted during the O=O discussions. This was Westcott's copy which was destroyed when Whare Ra closed; To the best of my knowledge, no other copy of this document exists in the New Zealand Order.

The god-form of Osiris never moves from the Dais. When the Hierophant has to move from the Dais, s/he is covered in the form of Osiris in action—Aroueris, which is built up by the Past Hierophant, seated on the Hierophant's left. If no one is seated as past Hierophant, then Inner Members help the Hierophant to formulate the second god-form.

Aroueris, or Horus the Elder, is very lively to look upon—like pure flames. He wears a Double Crown of Egypt, the cone-shaped crown in red inside the White Crown of the North, with a white plume. His nemyss is purple banded with gold at the edges. His face and body are translucent scarlet. He has green eyes and wears the purple beard of authority. He wears a yellow tunic with a waistcloth of yellow striped with purple, from which depends a

lion's tail. In common with all Egyptian Gods, he has a white linen kilt showing like an apron under the colored waistcloth. His armlets and anklets are of gold. He carries in his right hand a blue Phoenix Wand and in his left a blue Ankh_ He stands on a pavement of purple and gold.

Hiereus: Horus in the abode of Blindness unto and Ignorance of the Higher Avenger of the Gods (see Figure 5).

He wears the Double Crown of the South and North, red and white, over a nemyss of scarlet banded with emerald green. His face is that of a lively hawk—tawny and black with bright, piercing eyes; his throat is white. His body, like that of Aroueris, is entirely scarlet. He wears a collar, armlets, and anklets of emerald; a waistcloth of emerald striped red, from which depends a lion's tail, and he carries in his right hand an Emerald Phoenix Wand and in his left a Blue Ankh. He stands on a pavement of emerald and scarlet.

Hegemon: Thmaa-Est "Before the Face of the Gods in the place of the Threshold."

Thmaa-est wears a black nemyss bound at the brow with a purple band from which rises, in front, a tall ostrich feather of green striped with red in equal bands. (A version of this goddess is shown in Figure 6.) She wears a banded collar of red, yellow, blue, and black. Her tunic is emerald green to the feet, where it is banded to match the collar. She has purple and green shoulder straps and a purple girdle also bordered in the colors mentioned above. Her face and body are natural color—i.e., a light Egyptian red-brown. She wears armlets of emerald and red and carries a combined form of Lotus and Phoenix Wand. It has an orange flower and a blue stem and ends in an orange Sign of the Binary. In her left hand, she carries a blue Ankh, and she stands on a pavement of yellow and purple bordered with blocks of red, blue, yellow, and black, in succession.

Kerux: Anubis of the East as shown in Figure 7. Watcher of the Gods.

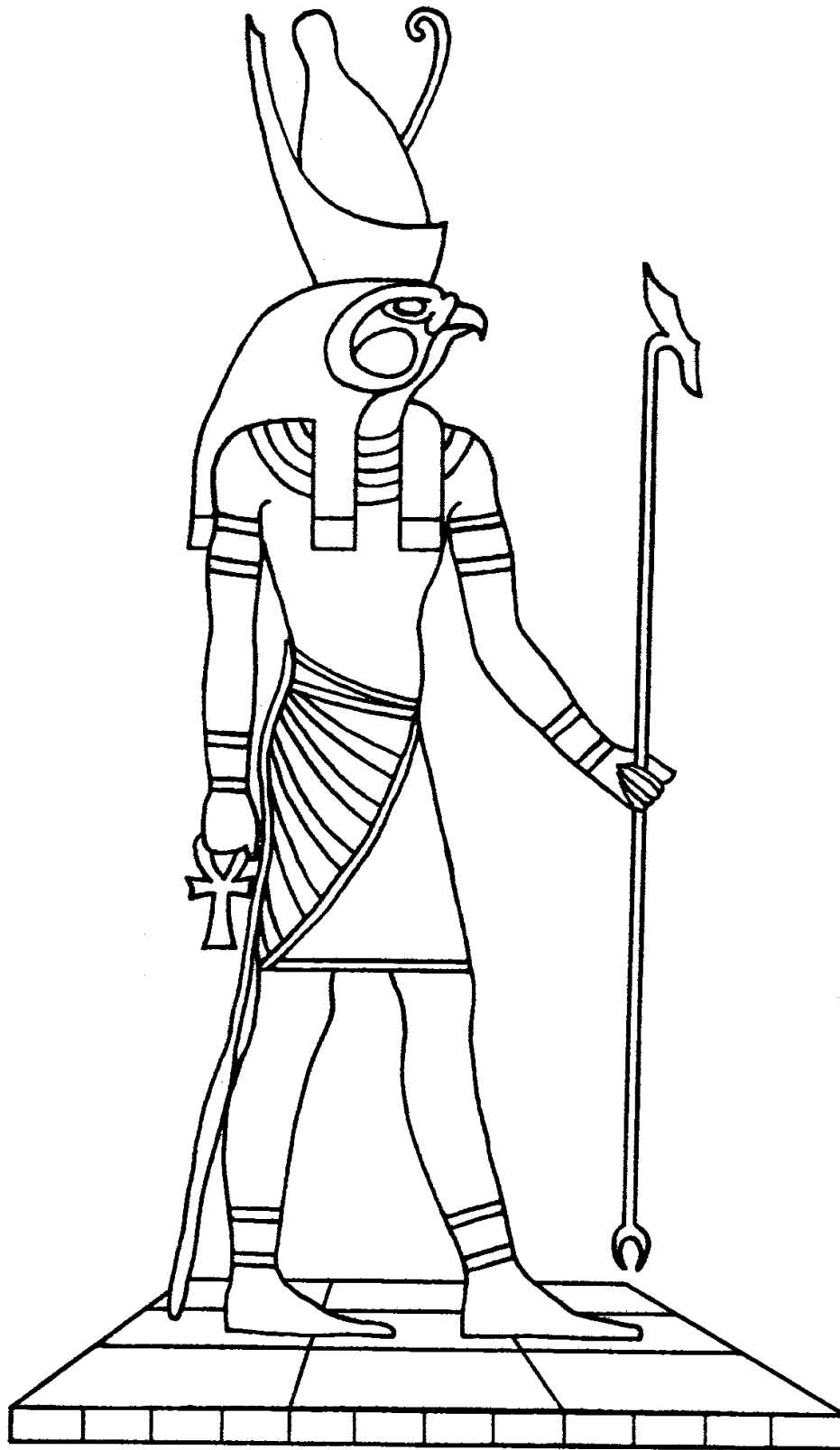

Figure 5
Horus

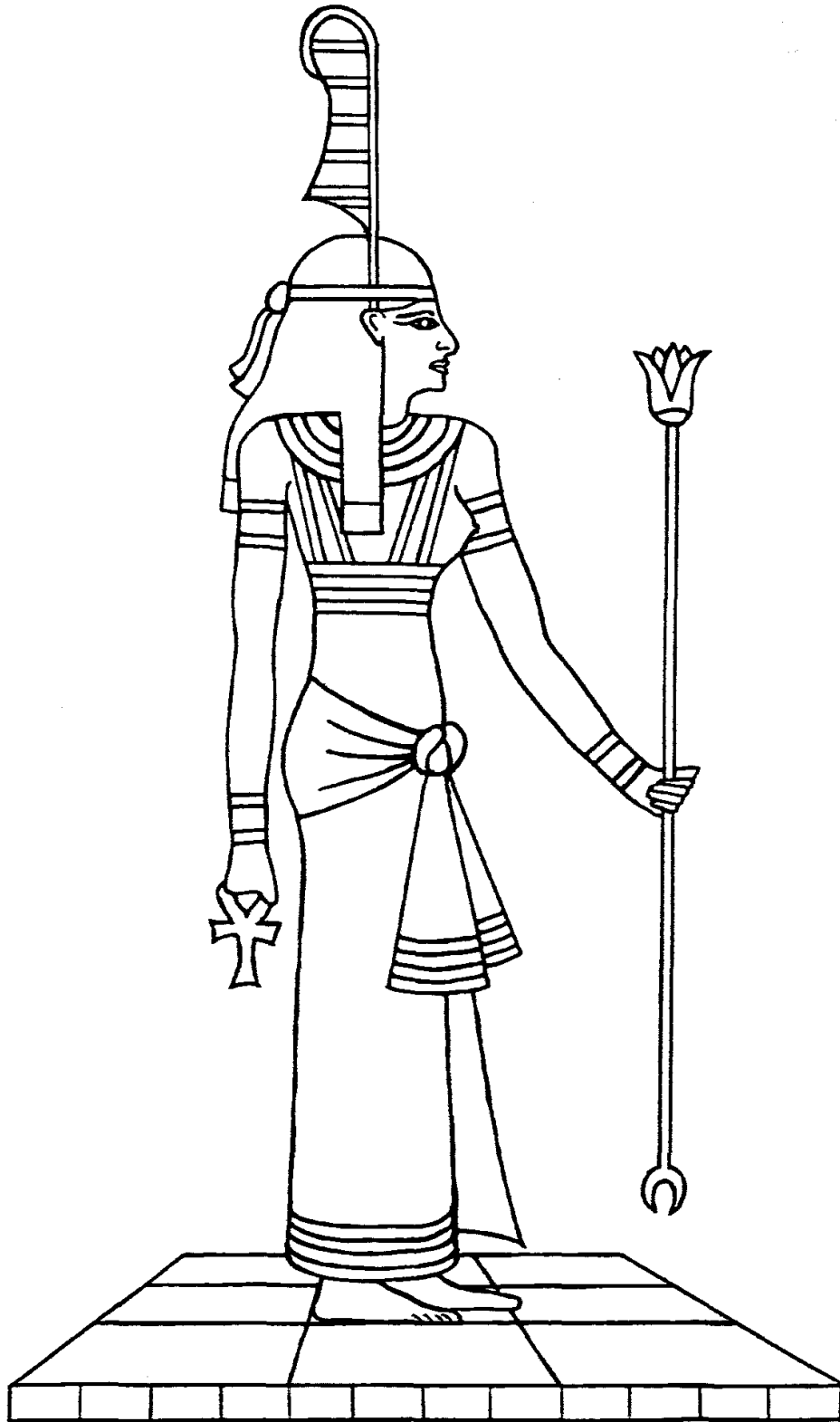

Figure 6
Thmaa-Est

Anubis has the head of a black jackal, very alert, pointed ears well pricked up. His nemyss is purple banded with white; he wears a collar of yellow and purple bands and a tunic of yellow flecked with tufts of black hair. His body is red. His waistcloth is yellow striped with purple, and from it hangs a lion's tail. His ornaments are purple and gold; his Phoenix Wand and Ankh are blue. He stands on a pavement of purple and yellow.

Stolistes: Auramo-ooth. "The Light shining through the Waters upon Earth" "Goddess of the Scales of the Balance at the Black Pillar"

Auramo-ooth is mainly in blue. Her face and body are natural. (A version of this god-form is shown in Figure 8.) She wears a blue Crown of the North from which springs a delicate gold plume over a vulture headdress of orange and blue. Her collar is orange and blue, she carries a blue Ankh and a Lotus Wand, having an orange lotus on a green stem. Her plain blue tunic reaches to the feet. She stands on black.

Dadouchos: Thaum-Aesch-Niaeth. "Perfection through Fire manifesting on Earth" "Goddess of the Scales of the Balance at the White Pillar"

Thaum-aesch is mainly in red. Her face and body are natural. (A version of this god-form is shown in Figure 9.) She wears a red Crown of the South flanked by two feathers in green barred black over a vulture headdress in red and green. Her collar is red and green, and she carries a green Ankh and a Lotus Wand with a red flower and green stem. Her simple red tunic reaches to her feet and she stands on black.

Sentinel: Anubis of the West.

His form is the same as that of Kerux, but his nemyss, ornaments, and dress are black and white. He has a lion's tail and carries a black Phoenix Wand and Ankh. He stands on black. Anubis of the West is shown in Figure 10.

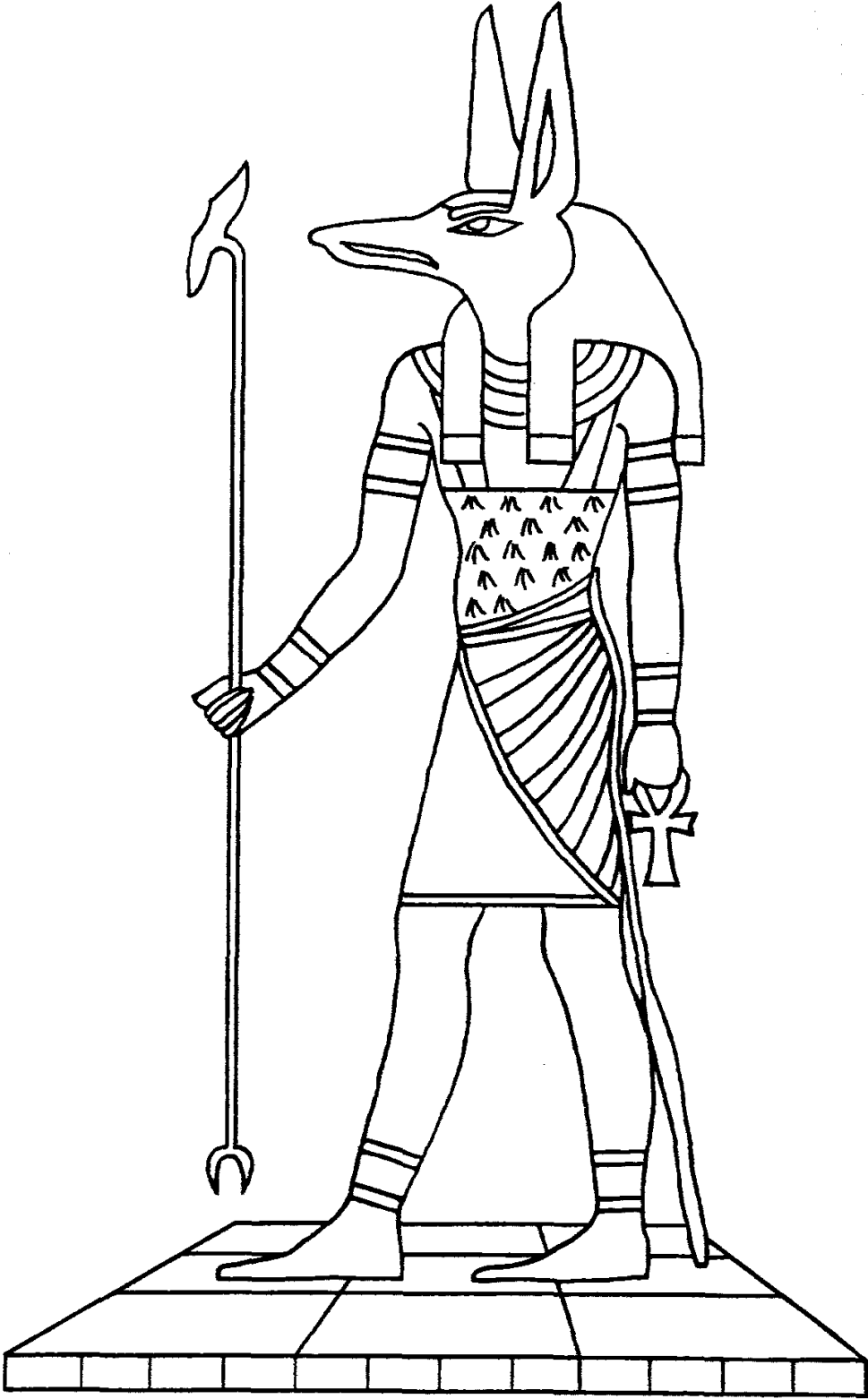

Figure 7
Anubis of the East

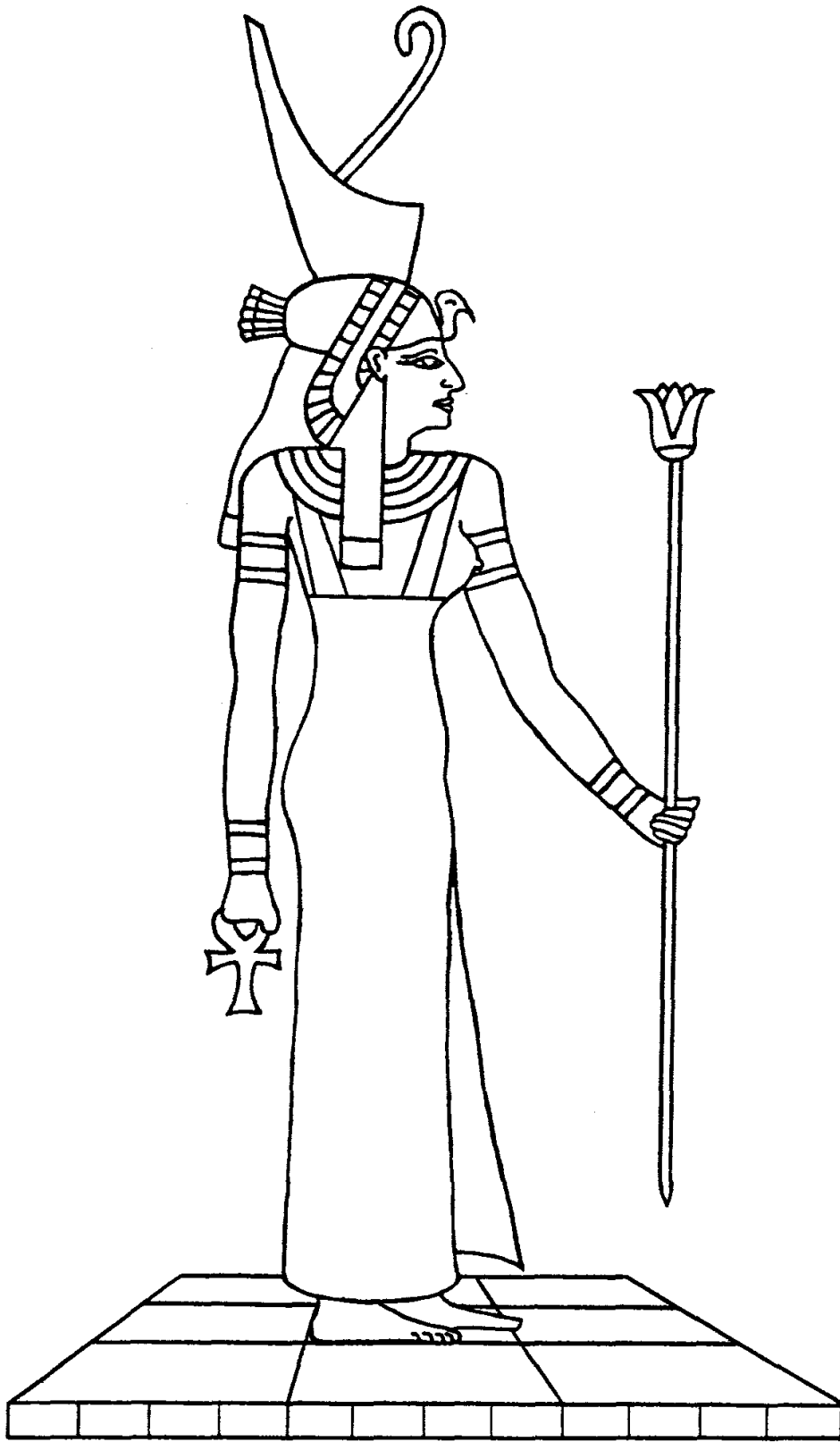

Figure 8
Auramo-Ooth

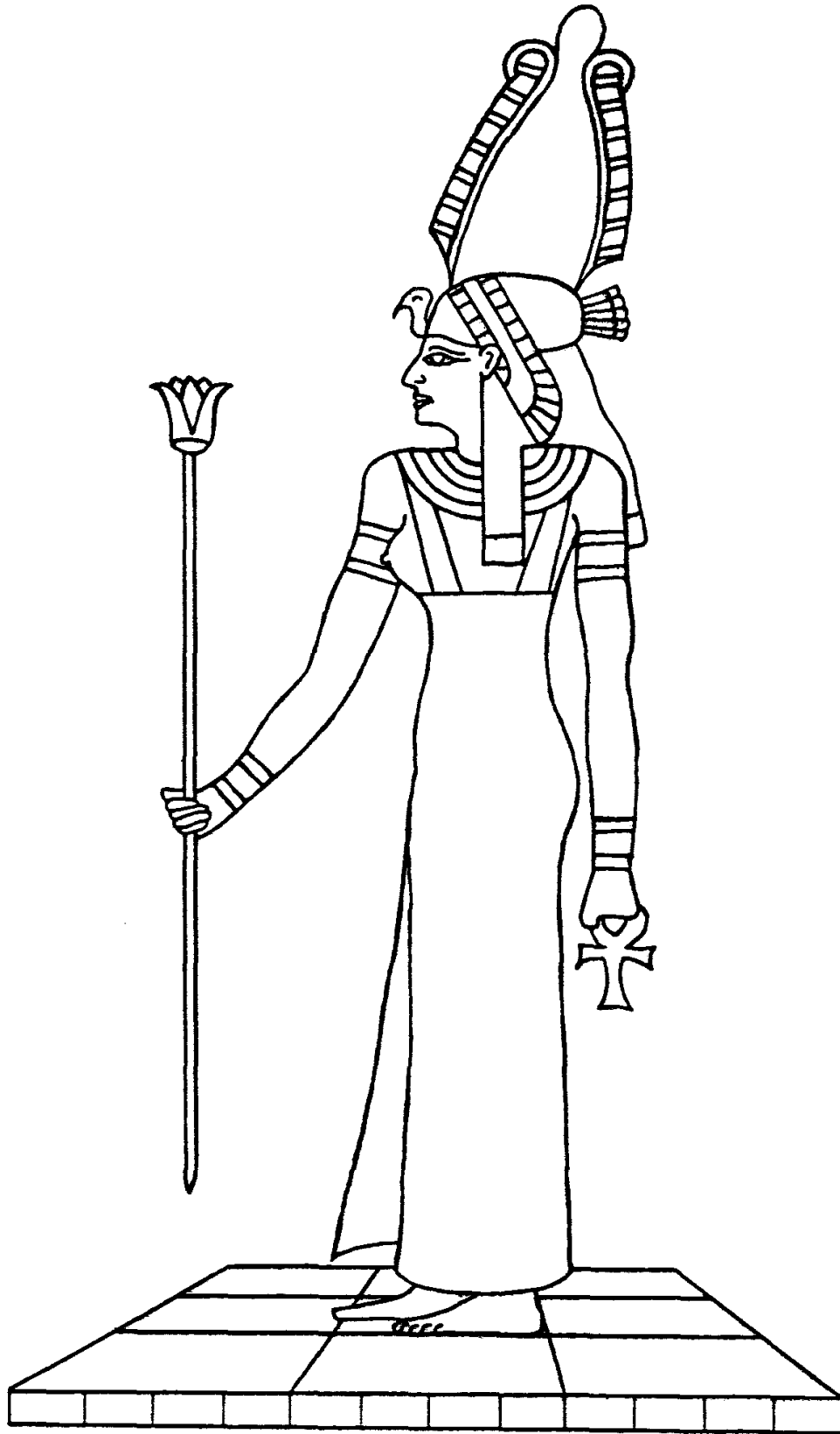

Figure 9
Thaum-Aesch-Niaeth

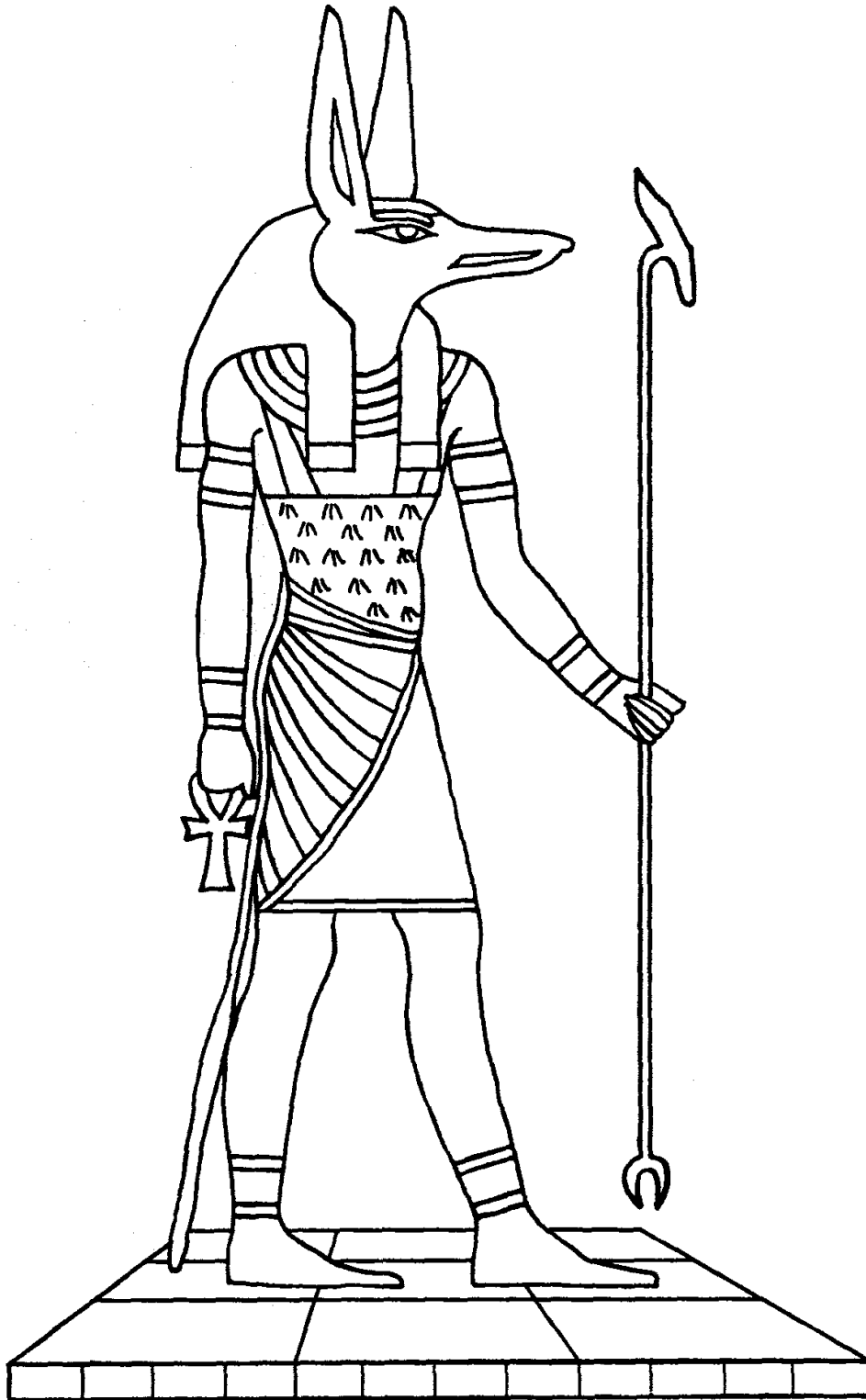

Figure 10
Anubis of the West

The Three Chiefs

Imperator: Nephthys

Nephthys has a face and body of translucent gold (see Figure 11). She is crowned with a cap over a vulture headdress of black and white, the vulture head being red. Her collar and ornaments are black and white, and she wears a black robe to the feet. It is bordered in black and white. She carries a blue Ankh and a Lotus Wand with a green flower and blue stem. She stands on black and white pavement.

Praemonstrator: Isis

Isis has a face and body of translucent gold (see Figure 12). She is crowned with a throne over a vulture headdress of blue and orange. The vulture head is red. Her robe is of blue bordered with gold. Her ornaments are blue and orange, and she carries a blue Ankh and Lotus Wand with a green flower and blue stem. She stands on blue and orange.

Cancellarius: Tho-oth

The god-form of Thoth is built up by the Cancellarius or the officer seated on the right of the Hierophant. This is his Visible Station; but, during a Neophyte Grade, he also has an Invisible Station in the East while the Obligation takes place.

He has an Ibis head, black beak, and white throat (see Figure 13). His nemyss is yellow bordered with mauve. His collar is yellow with a middle band of squares in mauve and green. His tunic is mauve with yellow stripes, and he has a lion's tail. His limbs are natural color; his ornaments are red and green. He carries a blue Ankh and a stylus and writing tablet. He stands on mauve and yellow.

The Invisible Stations

These fall naturally into four groups given below in their order of importance.

1. Stations in the Path Samekh in the Middle Pillar—Hathor, Harparkraat, Evil persona.



Figure 11
Nephthys



Figure 12
Isis

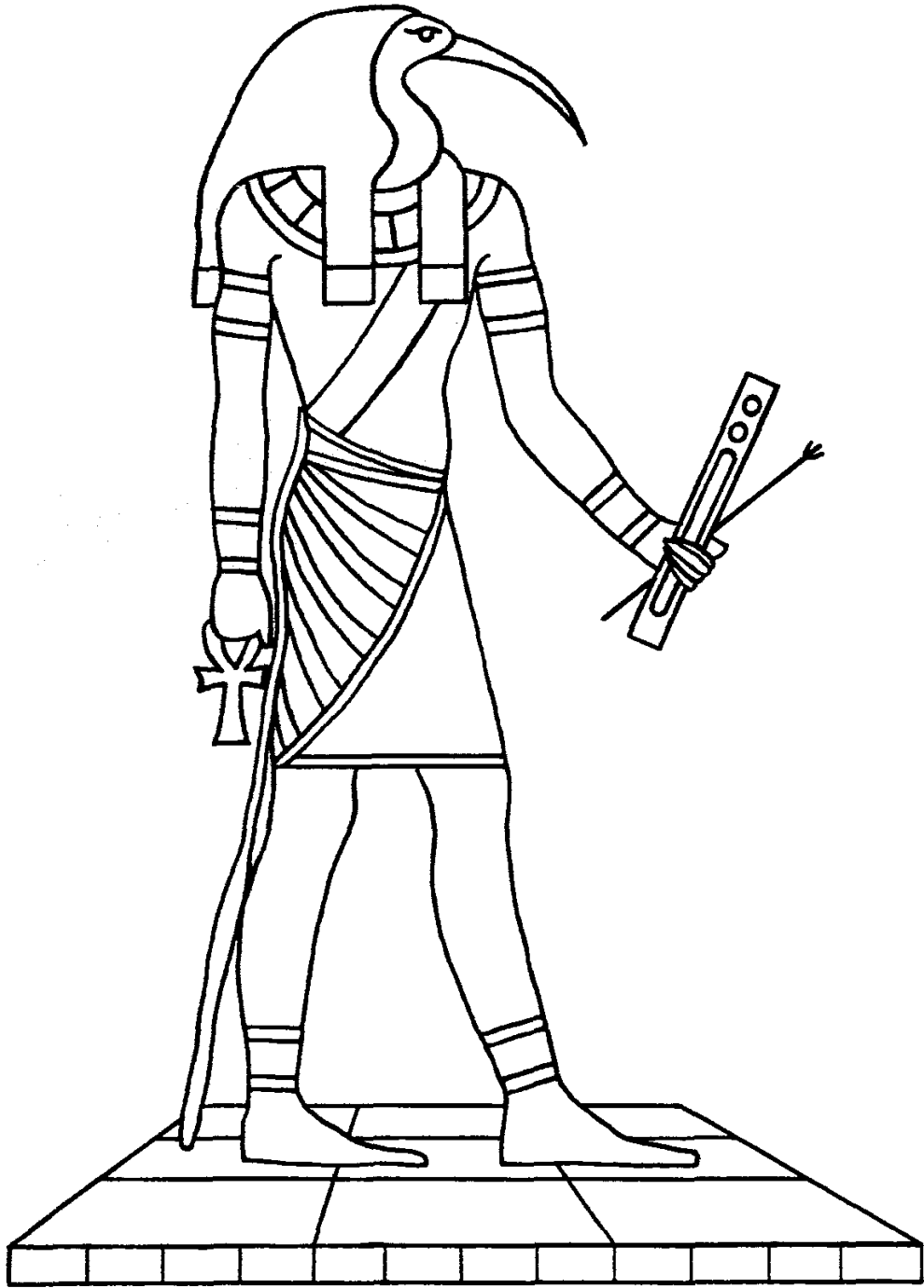

Figure 13
Thoth

2. Kerubim
3. Children of Horus
4. The Forty-Two Assessors

1. *Hathor*: This Great Goddess formulates behind the Hierophant in the East (see Figure 14). Her face and limbs are of translucent gold. She wears a scarlet Sun Disc resting between black horns from the back of which rise two feathers in white, barred blue. She has a black nemyss. The colors of her collar follow the pattern of blue, red, and blue. Blue bands support her robe of orange, which is bordered with blue and red. Her ornaments are blue and orange. She carries a blue Ankh and a Lotus Wand with a green flower and a blue stem. She stands on black bordered with blue.

Harparkraat: He formulates in the center of the Hall between Hegemon and the Altar, where he sits or stands on a Lotus facing East (see Figure 15). His face and body are translucent emerald green. He has blue eyes and a curl of blue hair, denoting youth, comes round his face on the right side. He wears the double crown, red and white. His collar is yellow and blue; his waistcloth is yellow and blue with a mauve girdle, whence depends a lion's tail. His Lotus has leaves alternately blue and yellow and rests on a pavement of mauve and orange. He has no insignia. His left forefinger is on his lips.

Omoo-Sathan. Typhon, Apophis, Set: The Evil Persona is a composite figure of the powers arising from the Qlipboth (see Figure 16). It rises from the base of the altar standing east of the altar facing West, in the Sign of Typhon. He is black and has an animal, somewhat lizard-like head and a black body and tail. He stands on black. His nemyss is of olive green decorated with russet, his collar of russet and citrine. He has a white apron and waistcloth of dull red striped with russet. He has no ornaments.

2. *The Kerubim*.

The Kerub of Air is formed behind Hathor, and she is a power of Hathor and has the same general coloring (see Figure 17). She



Figure 14
Hathor

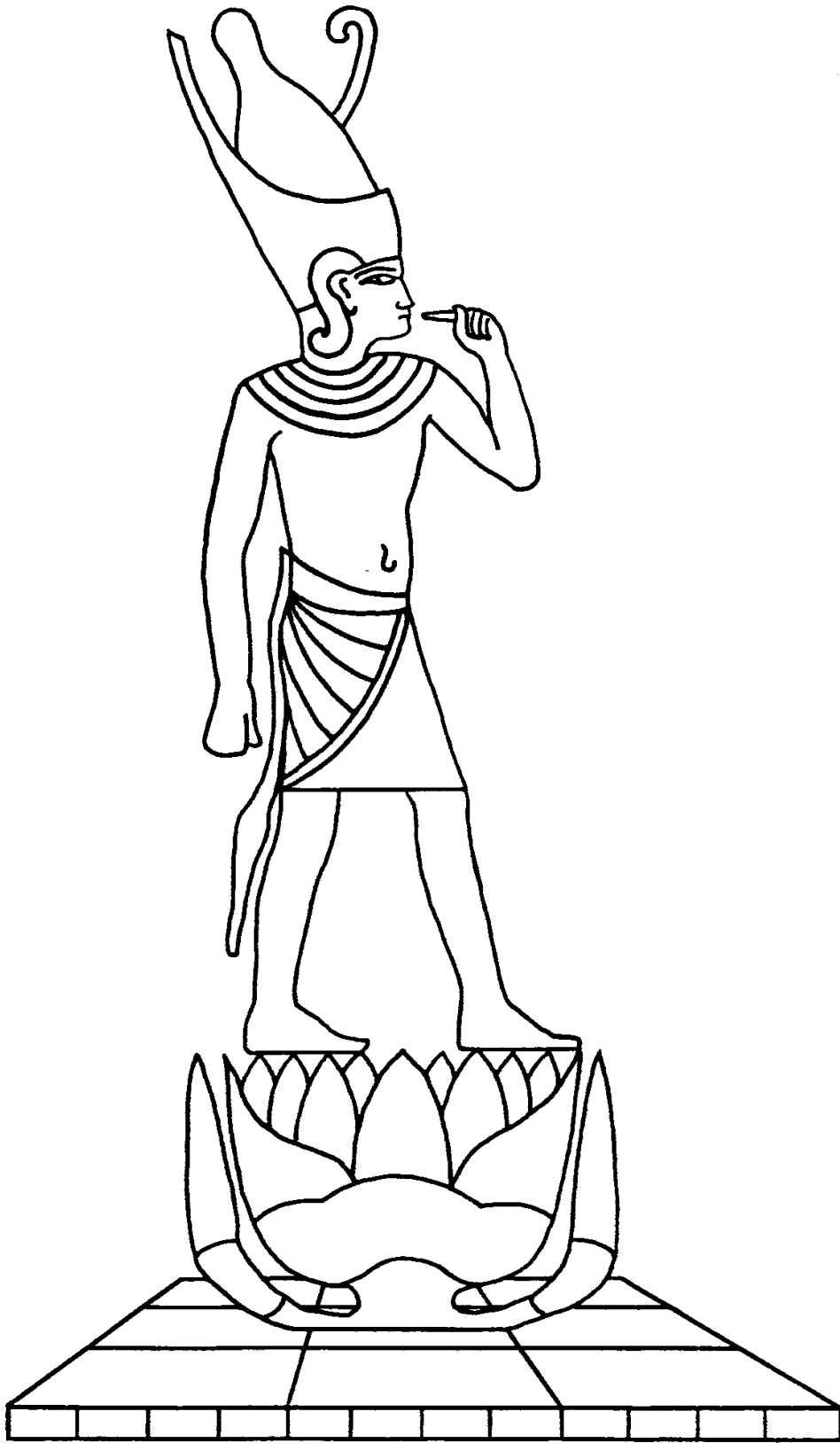

Figure 15
Harpokrat



Figure 16
Omoo-Sathan

has a young girl's countenance and behind her are spread large and shadowing wings.

The Kerub of Fire is in the South beyond the seat of Dadouchos (see Figure 18). It is a power of the Great Goddess Tharpesch, and has the face and form of a Lion with large and clashing wings. The coloring is very lively and flashing green with ruby and flame blue and emerald green



Figure 17
Kerub of Air



Figure 18
Kerub of Fire

The Kerub of Water is formed behind Hiereus and is the power of the Great God Toum or Tmu (see Figure 19). It has the face and form of a great Eagle with large and glistening wings. The colors are mostly blue and orange with some green.

The Kerub of Earth is in the North behind the seat of Stolistes (see Figure 20). It is a power of the Great God Ahapshi and has the face and form of a Bull with heavy darkening wings, and the colors are black, green, red with some white.

These forms are not described in detail. We are to imagine them as great stabilizing forces whose forms vary according to circumstances.

3. *Children of Horus.*

These have their invisible stations in the corners of the Hall. They are the guardians of the viscera of the human being—every part of whom comes up for judgment in its right time and place.

Ameshet: The man-faced god is in the Northeast. He has a blue nemyss banded with red, blue, and black. His face is red and has a black ceremonial beard. Round the shoulders of his white mummy shape are bands of red, blue, and black, three times repeated. He stands on red, blue, and black with a border of green, white, and yellow. He is shown in Figure 21.

Tmoopathpah: The jackal-headed god is in the Southeast. He has a black face with yellow linings to his pointed ears. He wears a blue nemyss with borders of black, yellow, and blue—the same colors appearing threefold at his shoulders. He has a white mummy shape and stands on blue, yellow and black with a border of green, yellow, and mauve. He is shown in Figure 22.

Kabexnuw: The hawk-faced god is in the Northwest. He has a black, tawny face and a nemyss of black bordered with red, yellow, and black. The same colors appear threefold at his shoulders. He has a white mummy shape and stands on red, yellow, and black with a border of green, mauve, and white. He is shown in Figure 23.



Figure 19
Kerub of Water



Figure 20
Kerub of Earth

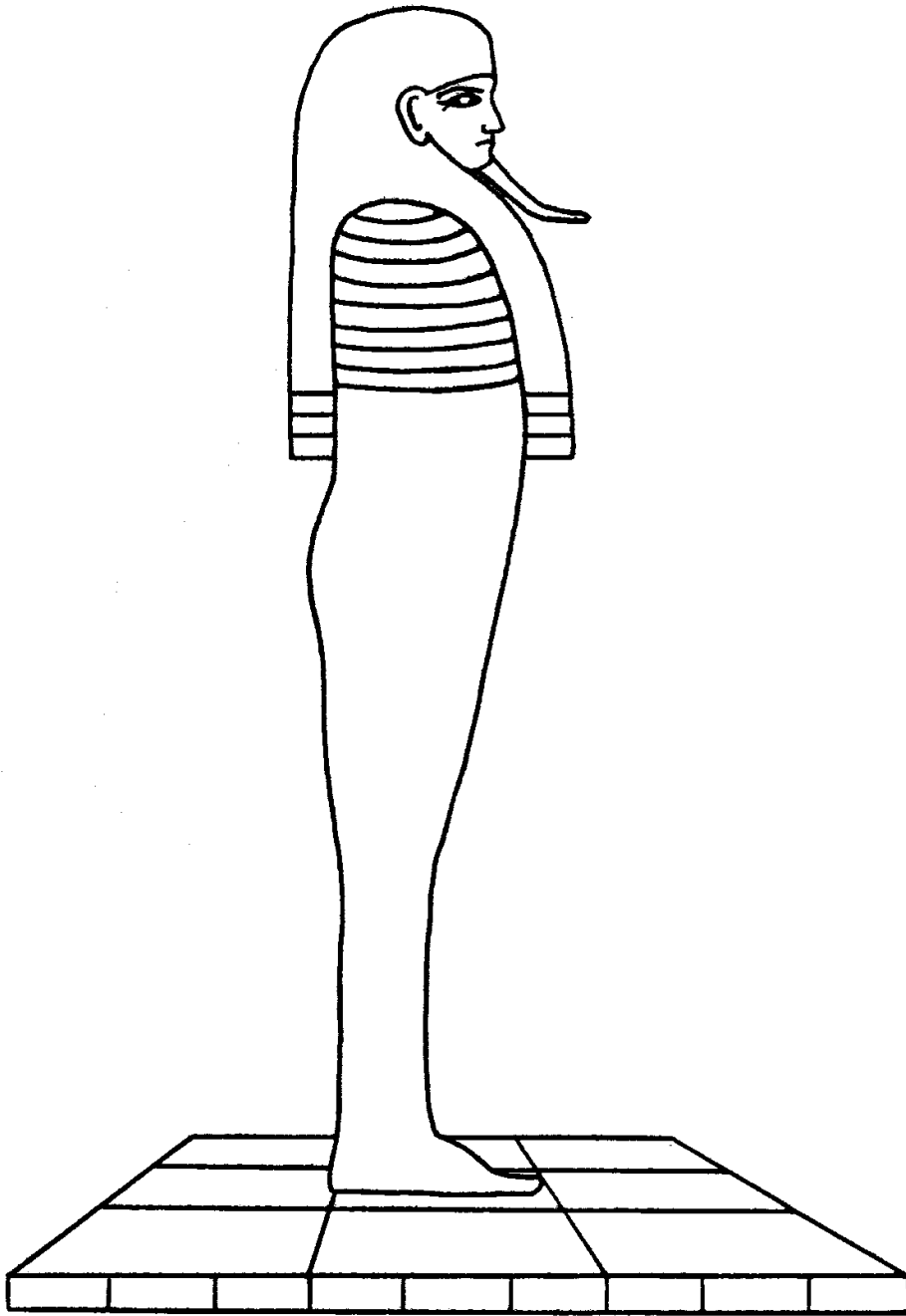

Figure 21
Ameshet

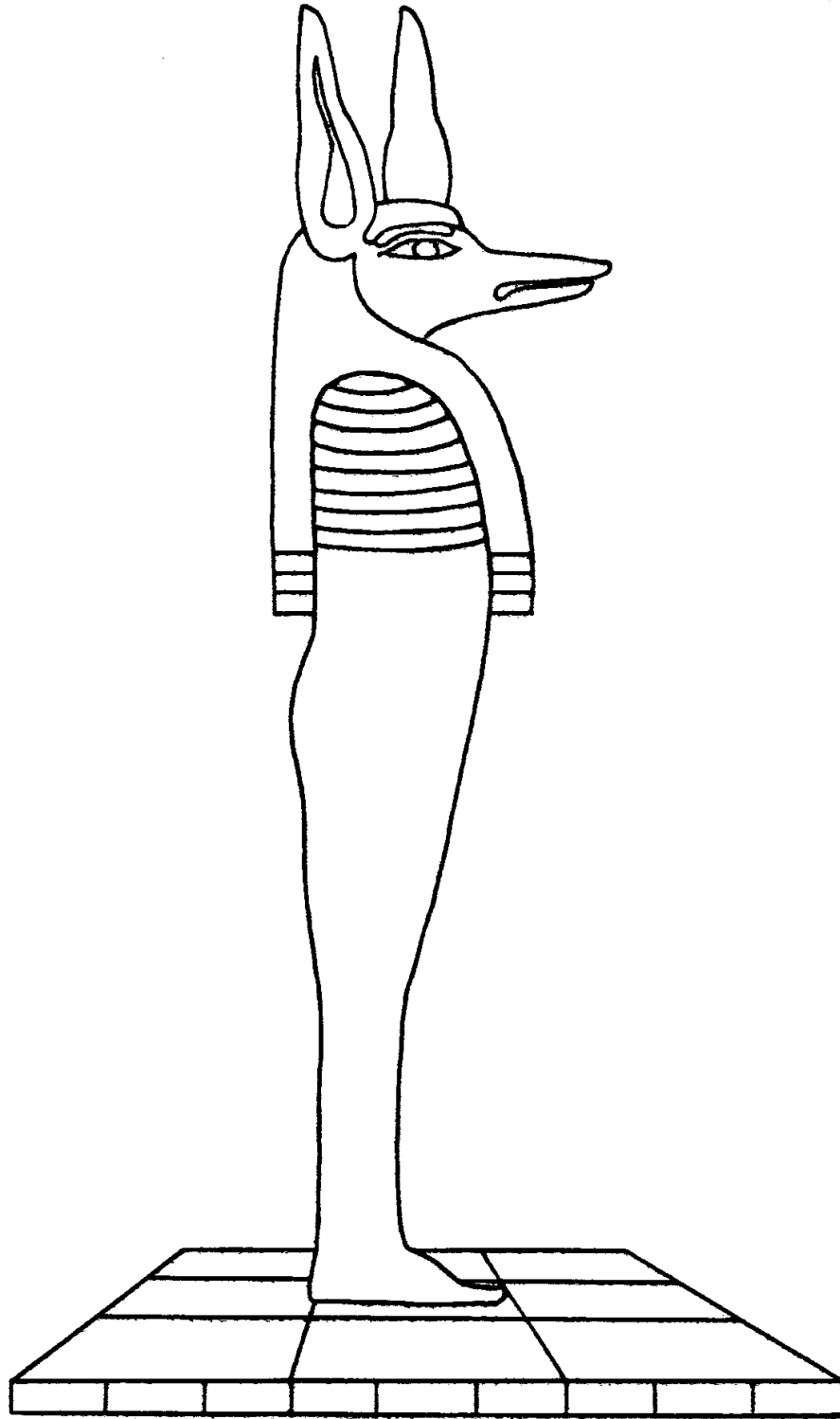

Figure 22
Tmooathpah

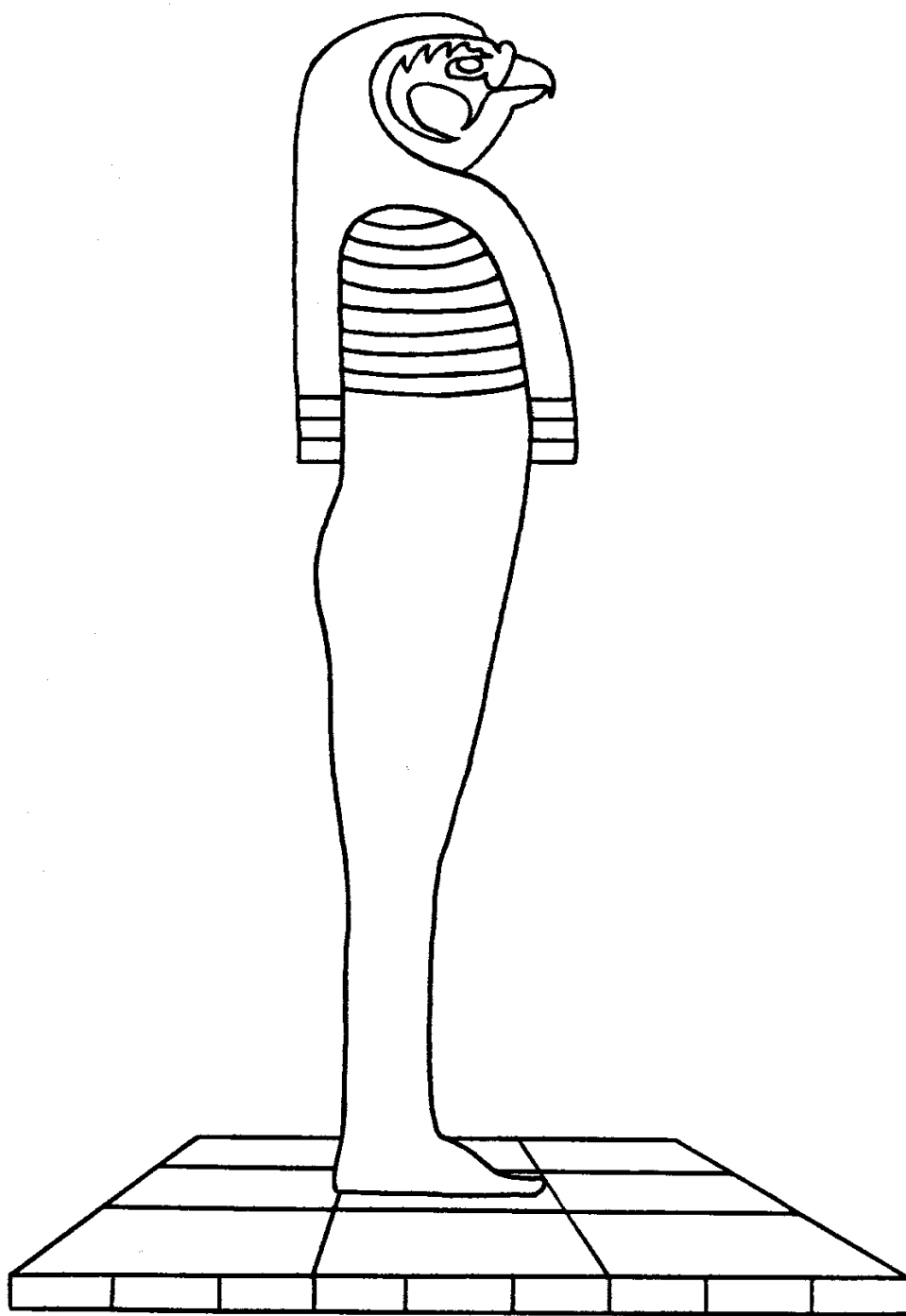

Figure 23
Kabexnuv

Aphepi: The ape-faced god is in the Southwest. He has a blue nemyss bordered with red, blue, and yellow bands. These colors appear on his shoulders in the same order. His face is red, and he stands on red, blue, and yellow with a border of green, orange, and mauve. He is shown in Figure 24.

Note: Tmoomathaph is sometimes written Duamutef. Kabexnuv is sometimes written Qebhesenef. Aphepi is sometimes written Mestri or Hapi, while Ameshet is sometimes written Mesti.

4. *The Forty-Two Assessors*. These are not described at all save to say that they make the sign of the Enterer as the Candidate is passed by. They are Witnesses in the Judgment Hall of Osiris.

Note: Clairvoyant members of the Order have shown that the 42 Assessors are placed along the Path of Samekh and above the station of the evil triad. They are back to back and form a length of 21 members. Their descriptions vary, but they are often seen with a variety of animal heads, holding upraised swords. Though placed along this Path, they are far from stationary and rotate slowly, but there are always two lines of 21. Their actual function in the ritual is to create a vortex in various parts of the ceremony that enables them to directly judge the Candidate and his/her Higher Self. (They are placed not at floor level, but at a point just above the height of the Pillars.) This vortex helps keep the Higher Self safe once it has left the body of the Candidate. They also ensure that he/she is judged correctly and they bring to the ceremony a power which is very much like that of the Canopic Gods, only far more detailed. It is their function to examine the Candidate further and test him/her deeper and longer than the length of the ceremony. The 42 Assessors are said to follow and watch the Candidate as he or she goes through each grade and, if found wanting, they will immediately sever his or her link with the Order with the swords they hold. In theory, they remain with the Candidate until admittance to the Inner Order, and it is they who are sometimes responsible for people who leave the Outer Order, barring their admittance to the Inner Order. Each Assessor is related to each letter of the 42 lettered name of God

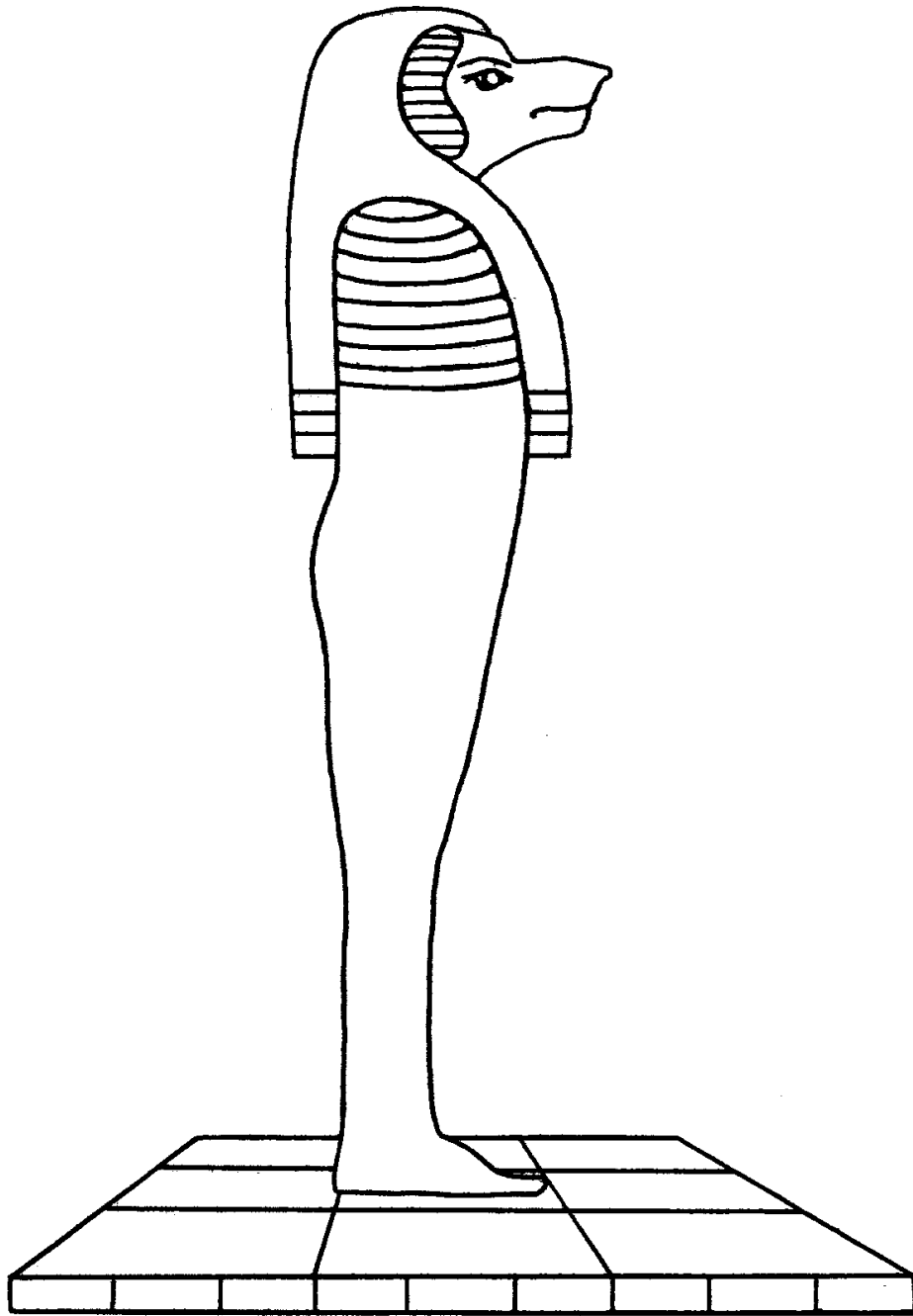

Figure 24
Aphepi

(which, according to an unpublished Golden Dawn manuscript by Westcott, relates to the Notariqon of the 42 virtues from the 3 consonants of YHVH spelled out) which governs a certain portion of man. The following table, related to the Sephiroth, is the Regardie association of psychological complexes to the Kabbalah.

The Forty-Two Assessors

Name of God	Sephiroth	Part Affected	Assessors
AB	Kether	Id	1. Usekh-nemtet 2. Hept-seshet
GY	Chokmah	Animus	3. Fenti 4. Am-khaibitu
ThTz	Binah	Anima	5. Neha-hra 6. Restau
QROShMN	Chesed	Conscious Ego	7. Maata-f-em-seshet (memory) 8. Neba 9. Set-qesu 10. Khemi 11. Uatch-nesert 12. Hra-f-ha-f
KGDYSh	Geburah	Conscious Ego	13. Qerti (will) 14. Ta-ret 15. Hetch-abehu 16. Am-senef 17. Am-besek 18. Neb-Maat
BMRTThG	Tiphareth	Conscious Ego	19. Thenemi (imagination) 20. Anti 21. Tututef 22. Uamemti 23. Maa-ant-f 24. Her-seru
HQMMNO	Netzach	Conscious Ego	25. Neb-Sekhem (desire) 26. Seshet-kheru 27. Nekhen 28. Kenemti 29. Kenemti (?)

The Forty-Two Assessors (cont'd.)

Name of God	Sephiroth	Part Affected	Assessors
YGLPZQ	Hod	Conscious Ego	30. Ser-kheru 31. Neb-hrau (reason) 32. Serekhi 33. Neb-abu 34. Nefer-Tem
ShQY	Yesod	Endopsychic	37. Ahi Structure 38. Uatch-rekhit 39. Neheb-nefert
OYTh	Malkuth	Sense Organs	40. Neheb-kau 41. Tcheser-tep 42. An-a-f

Symbolism of the Temple

The Hall of the Neophytes is called "The Hall of the Dual Manifestation of Truth"; that is, "The Hall of the Goddess Thmaah." Her name has three forms, according to the nature of her operation. (See Figure 2 for these three forms in the place of Hegemon.) This is based on Chapters from the Egyptian *Book of the Dead*, modified for Golden Dawn usage.

The second set of major symbolism in the 0=0 blueprint is Kabbalistic and considers an arrangement in the manner of the Sephiroth. The Temple is placed looking towards the YH of YHVH in Malkuth of Assiah. (Y and H answer to the Sephiroth of Chokmah and Binah on the Tree of Life and also to Abba and Aima, through whose knowledge Kether may be obtained.) The Sacred Rites of the Temple should gradually lead the Neophyte into the knowledge of his or her Higher Self. Like the other Sephiroth, Malkuth has also its subsidiary Sephiroth and Paths. Of these ten Sephiroth, the Temple, as arranged in the Neophyte Grade, includes only the lower Sephiroth on the Tree of Life; viz., Malkuth, Yesod, Hod, Netzach, and the outer side of Paroketh, the Veil. Paroketh forms the East of the Temple. The symbolism of the East is of primary importance here.

The bases of the two Pillars are respectively placed in Netzach and Hod; the White Pillar is in Netzach; the Black Pillar is in Hod. They represent the Two Pillars of Mercy and Severity. The bases are cubical and black to represent the Earth element in

Malkuth. The columns are respectively black and white to represent the manifestation of the eternal balance of the Scales of Justice. Upon them should be represented, in counter-changed color, any appropriate Egyptian designs emblematic of the soul (see Chapter 3 for a full discussion of this).

The scarlet tetrahedral capitals represent the Fire of Test and Trial. Between the Pillars is the porchway of the Region Immeasurable. The twin lights which burn on their summits are "The Declarers of the Eternal Truth." The bases of the tetrahedra are triangular. The base of the White Pillar points East, while that of the Black Pillar points West. They thus complete the hexagram of Tiphareth—though separate, as is fitting in "The Hall of the Dual Manifestation of Truth."

The Altar, whose form is that of a double cube, is placed in the eastern part of Malkuth—as far as the Neophyte is concerned. But to the Adeptus Minor, its blackness will veil on the East citrine, on the South olive, and on the North russet, while the West side and the base will be black and the summit is a Brilliant Whiteness.

The symbols on the Altar represent the Forces and the manifestation of the Divine Light. These are concentrated in the White Triangle of the Three Supernals as the synthesis. Upon this sacred and sublime Symbol, the Obligation of the Neophyte is taken. It calls to witness the Forces of the Divine Light.

The Red Cross of Tiphareth (to which the Grade of 5=6 is referred) is placed above the White Triangle, not as dominating it, but as bringing it down and manifesting it unto the Outer Order. It is as though the Crucified One, having raised the symbol of self-sacrifice, had thus touched and brought into action in matter the Divine Triad of Light.

Around the Cross are the symbols of the Four Letters of the Name Jehovah—the Shin of Yeheshuah being only implied and not expressed in the Outer Order. At the East is the Mystical Rose, allied by its scent to the element Air. At the South is the Red Lamp, allied by its Flame with the Element of Fire. At the West is the Cup of Wine, allied by its fluid form to the Element of Water. At the North are Bread and Salt, allied by their substance

to the Element of Earth.

The Elements are placed on the Altar according to the Four Winds.
For Osiris on-Nophris, who is found perfect before the Gods, hath said:

These are Elements of my Body,
Perfected through Suffering, Glorified through Trial.
For the scent of the Dying Rose is as the repressed sigh of my
suffering:

And the flame-red Fire as the Energy of mine Undaunted Will: And
the Cup of Wine is the pouring out of the Blood of my Heart:
Sacrificed unto Regeneration, unto the Newer Life:

And the bread and Salt are as the Foundations of my Body,
Which I destroy in order that they may be renewed.

For I am Osiris Triumphant, even Osiris on-Nophris, the
Justified:

I am He who is clothed with the Body of Flesh,

Yet in whom is the Spirit of the Great Gods:

I am the Lord of Life, triumphant over Death.

He who partaketh with me shall arise with me:

I am the Manifestor in Matter of Those Whose Abode is in the
Invisible:

I am purified: I stand upon the Universe:

I am its Reconciler with the Eternal Gods:

I am the Perfector of Matter:

And without me, the Universe is not.

Technically, the Door of the Hall is supposed to be situated behind the seat of the Hieres in the West. However, it may be in any part of the Hall, seeing that the walls represent the barrier to the exterior. But this is not always the case, for the barrier is also called the Portal and can be situated within the Hall, usually shaped in an oval fashion.

The corners of the Hall, which are deemed as exterior to the Portal and still within the confines of the Four Children of Horus, are the places where all members of the Temple who wish to view the ceremony are located. They may partake in the circumambulation and, partaking of the Eucharist, they may sit [the seats are in the northwest (0=0), northeast (1=10), west (2=9),

southwest (3=8), and northwest (4=7); no seating is behind the Dais for Outer Order members, but those of the Inner Order can be seated there]. When the Hall is small, then the Portal may exceed to the physical barriers of the walls. "The Gate of the Declarers of Judgment" is the name of the Door—its symbolic form is that of a straight and narrow doorway, between the two Mighty Pylons. "The Watcher against the Evil Ones" is the name of the Sentinel who guards, and his/her form is the symbolic one of Anubis.

*The Stations, Descriptions and Meanings
of the Officers
Hierophant*

The Hierophant is placed in the East of the Temple, on the outer side of the Veil of Paroketh (shown in the ritual as a transparent curtain) to rule under the presidency of the Chiefs. S/he is placed in the East because that is where the Sun, ruler of Life, rises. From this position, s/he governs the Hall. In the ancient Mysteries, he was the officer who taught the Rites of Sacrifice and Worship, and he was the Chief Initiating Priest at Eleusis and the equivalent to the Roman *Pontifex Maximus*, or High Priest. The word *hierophantos* is derived from *hieros* and *phaino*, which means "to show forth," "expound," or "teach." He was the head of the ancient Eleusian cult and chosen for life from the hieratic family of the Eumolpidae. Since he was the expounder of the Mysteries, it was necessary that a man of impressive voice should be chosen. This was an office of great responsibility. It is on record that any ancient Hierophant who had publicly shown himself in his ceremonial robes suffered death as a penalty for his indiscretion.

The Hierophant fills the place of a Lord of the Paths of the Portal of the Vault of the Adepts, acting as inductor to the Sacred Mysteries. The Insignia and symbols of the Hierophant are:

- (1) The Throne of the East in the Path of Samekh, outside the Veil.
- (2) The mantle of bright flame scarlet, bearing a white cross on the left breast and the Robe of Scarlet.

- (3) The lamén suspended from a white collar.
- (4) The Scepter of Power.
- (5) The Banner of the East.
- (6) The scarlet-and-white-striped nemyss.

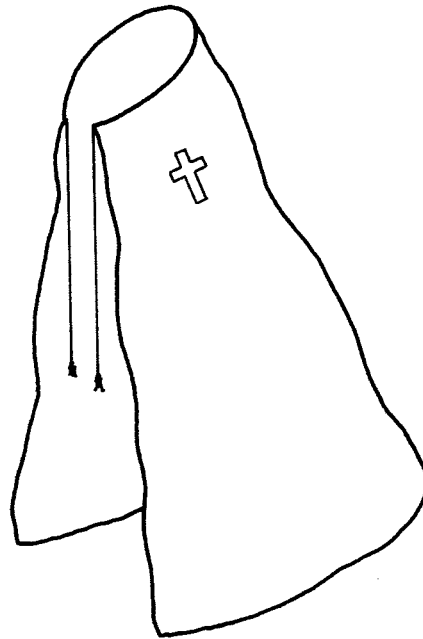

Figure 25
The Mantle or Robe of the Hierophant

The position of the throne on the Path of Samekh is fitting for the Inductor to the Mysteries. It is placed in that balanced and central position of that Path by which alone is safe entrance to the mystical knowledge of the Light in Tiphareth. It is placed before Paroketh at the point of its rending. There it marks the shining forth of the Light through the Veil. The translation of the Three Supernals to the Outer Order is represented by the Red Calvary Cross and the White Triangle upon the Altar. Thus the station of the Hierophant's Throne fitly represents the rising of the Sun of Life and Light upon our Order (see Figure 2).

The mantle or cloak, plus the robe of scarlet, represents the flaming energy of the Divine Light shining forth through infinite worlds. It is shown in Figure 25. Upon the left breast of the cloak, there is a white cross to represent the purification unto the Light. The white cross on the mantle is a Calvary Cross, which alludes to the Four Rivers of Eden as well as to the suffering to bring about redemption. In the Z.1 document, there is some confusion as to the terms "robe" and "mantle" and their colors. The statement that all members on the Dais wore white robes contradicts earlier statements that robe colors were varied according to the color of the office. In the New Zealand Order, the robes are the same color as the mantle for the officers on the Dais. One version of the Z.1 at Whare Ra, which was reputedly copied from Wynn Westcott's copy, had the reference to the officers of the Dais wearing white robes crossed out, with the note "refer to the above.—S.A." "S.A." was Westcott's Order motto. Taylor was of the opinion that those on the Dais functioned much better through total colors than through partial ones.

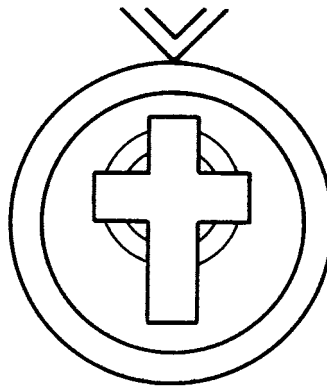

Figure 26
The Lamen of the Hierophant

The lamen of the Hierophant, shown in Figure 26, is partially explained in the Portal Ceremony thus:

The Hierophant's Lamén is a synthesis of Tiphareth, to which the Calvary Cross of the six squares, forming the cube opened out, is fittingly referred. The two colors, red and green, the most active and the most passive, whose conjunction points out the most practical application of the knowledge of equilibrium, are symbolic of the reconciliation of the celestial essences of Fire and Water. For the reconciling yellow unites with blue in green, which is the complementary color to blue. The small inner circle placed upon the Cross alludes to the Rose that is conjoined therewith in the symbolism of the Rose and Cross of our Order.

But, in addition to this, it represents the blazing light of the Fire of the Sun bringing into being the green vegetation of the otherwise barren Earth and also the power of self-sacrifice requisite in one who would essay to initiation into the sacred Mysteries. The lamén affirms the qualification necessary to him/her who uses it. Therefore, it is suspended from a white collar to represent the purity of the White Brilliance from Kether. Hence, it should always be worn by the Hierophant.

The scepter, shown in Figure 27, represents the Authority and Power of the Light. It is the smallest of the scepters held by those officers on the Dais, being no more than 20 inches in length. It represents the forces of the Middle Pillar. It is scarlet in color, with three gold bands on the shaft. These represent the Sephiroth of Daath, Tiphareth, and Yesod. The gold pommel at the base represents Malkuth. The shaft itself represents the Paths of Gimel, Samekh, and Tau. The grip, by which it is wielded, is the Path of Tau (the lowest portion of the shaft), representing the Universe governed by and attracting the forces of the Light.

The Names of the Sephiroth and Paths are not marked thereon, but the Hierophant Initiate of the Second Order should remember the sublimity of the symbolism while s/he wields it. It represents touching the Divine Light of Kether and attracting it through the Middle Path to Malkuth. It is called the "Scepter of Power" and invests him/her with the power of declaring the Temple Open or Closed in any Grade of the Outer Order. If time is short, then this is done by saying, "By the Power in me vested by

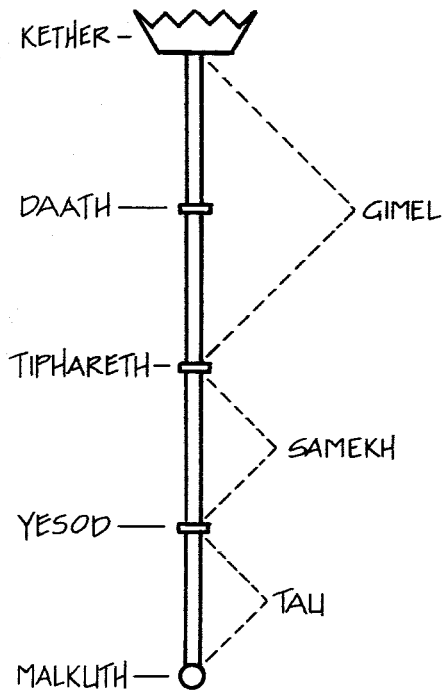

Figure 27
The Scepter of the Hierophant

this Scepter, I declare this Temple duly Opened (or Closed)." This method of Opening and Closing by Scepter should be only used in great emergencies, when time is pressed. It should not be used in a Ceremony where Elemental Spirits have been invoked.

The use of the scepter during ritual is not merely a vacant gesture of pointing it at the desired object for an effect. The scepter becomes an extension of the link between the Hierophant and the Second Order. It represents the power of Osiris, even when s/he takes the form of Aroueris. Once s/he has assumed the Astral Shell of Osiris, s/he then invokes this power to act through the scepter. It becomes a living extension and fusion of Osiris. When the scepter is pointed or directed during the 0=0 ceremony,

the power is directed through the Sephirah of lialkuth (at the base of the shaft); this then rises through the shaft, emitting the 12 rays through the miter-headed top of 12 poi s. These are in the color of the Queen Scale of Briah which, when united, form a White Brilliant Light.

In some Temples, this scepter had a crown of ten points, each representing a Sephirah. However, the rays they emitted were not considered balanced enough, and, though powerful, it was found by clairvoyant members that they were somewhat erratic. It sometimes took a great deal of effort for the Hierophant to control them. By using a 12-pointed miter, a definite change was felt, and the power of the scepter was definitely increased to a higher and more directionable level.

J. W. Brodie-Innes wrote a letter to Felkin about the imbalance of the ten-pointed scepter in 1896, though no solution was offered. Taylor and others at Whare Ra made similar comments. After a great deal of experimentation by Thoth-Hermes members, a 12-pointed miter head was found to be ideal.

The method by which the Hierophant utilizes this force is through his/her Tiphareth center. To be able to do this correctly, his/her sphere of sensation (aura) must be united (the joining of the Ruach and Neshamah) before the start of the ritual, through the scepter (used to call down the power) from the Second Order. As stated above, it must not be wielded for the invocation of Elemental Spirits. Its main function is to prepare a way through for the Light. Its action is literally based on a magnetic charge (hence the magnetized rod up through its shaft—like the Elemental Wand of the Adepti) to blast a path. Using this for Elemental invocations would be disastrous, as the ceremonies form an entirely different function to an Invocation through the Pentagram Ritual.

To give an example, the misuse of a scepter would be to use it to perform Regardie's brilliant "Opening by Watchtower" ceremony (which was based on the Consecration Ceremony of the Vault of the Adepti). In this instance, one would have a First Order Weapon being used through a Second Order Framework of Elemental Invocations, through the Invoking Ritual of the

Pentagram—the very thing the original Z.1 warns against (the correct weapons to use during the Opening by Watchtower are the Elemental Weapons or the Second Order Wand of the Chief Adepti).

The result of this ceremony would be that the power of the scepter would do little but inflate or falsify the Ego, having little or no effect on the actual result. A clairvoyant description of this would be to have red rays of energy emitting from the scepter—directly from the Chiefs own auric charge—and not from the Divine Light. This scepter, through repeated use, would be as disastrous (for the wielder) as playing with an atomic pile without protection—with a direct effect on the health of the wielder.

When viewing the correct use of the scepter by clairvoyance, one can see the colored rays form into a white light. Order clairvoyants such as Jack Taylor often informed us that the power of the ceremony can be judged by the effect generated through the use of the scepter. When colors such as red occur, it is because the wielder's magnetic emanations are not coming through the Second Order. (This is not to be confused with the red ray of Tiphareth which is sometimes emitted from this center, but this ray also undergoes a change in color when worked through the Scepter.)

The Banner of the East, shown in Figure 28, is partly explained in the Portal Ritual:

The field of the Banner of the East is White, the color of light and purity. As in the previous case, the Calvary Cross of six squares is the number six of Tiphareth, the yellow Cross of Solar Gold, and the cubical stone bearing in its center the sacred Tau of Life, and having bound together upon it the form of the Macrocosmic Hexagram, the red triangle of Fire and the blue triangle of Water—the Ruach Elohim and the Waters of Creation.

In addition to this explanation, it affirms the Mode of Action employed by the Divine Light in its operation by the Forces of Nature. Upon it is the symbol of the Macrocosm. This is colored to

affirm the action of the Fire of the Spirit through the Waters of Creation under the harmony of the Gold Cross of the reconciler. Within the center of the Hexagram is a Cross in White to represent its action as a Triad. The whole is placed on a white field representing the ocean of the Ain Soph Anr.

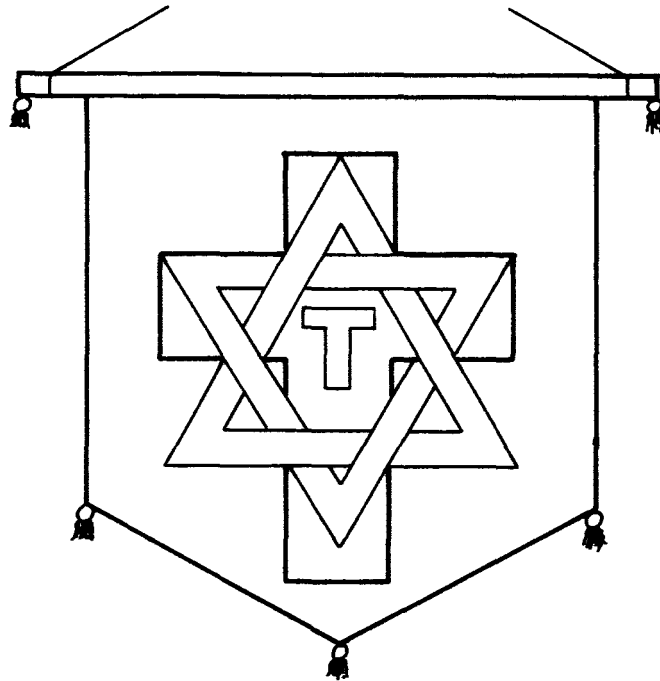

Figure 28
The Banner of the East

The banner is suspended from a gold-colored bar by red cords. The pole and base should be white. The base represents the purity of the foundation—the shaft, the Purified Will directed to the Higher. The golden cross-bar is that whereon the manifested Law of Perfection rests; the banner itself represents the perfect Law of the Universe, the red cords and tassels the divine self-renunciation, the trials and *sufferings* of which form, as it

were, the Ornament of the Completed Work. The whole represents the ascent of the initiate into Perfect Knowledge of the Light. Therefore, in the address of the Hierophant, the Neophyte hears, "Even the Banner of the East sinks in Adoration before Him," as though that symbol, great and potent though it be, were yet but an inferior presentiment of the Higher fitted to our comprehension.

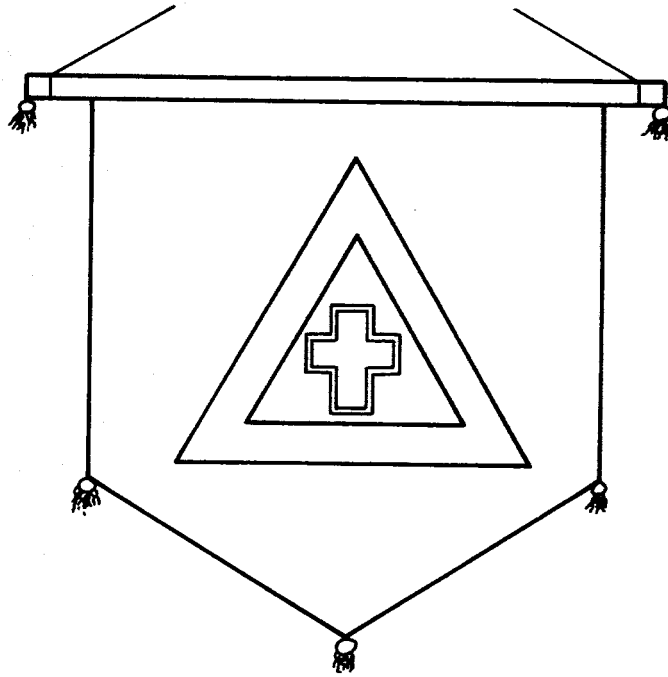

Figure 29
The Banner of the West

In simple terms, the Banner of the East helps fuse the link of the Hierophant to the Candidate. It also helps prevent obstruction to this link by its use as a shield that is designed to cast out the negative aspects before it by absorbing them into it. Since only the perfected work can be absorbed, the negative influences

are left aside. Again, this is not done through the mere action of holding the banner in front of one, but is done through the use of the Ruach of the Hierophant who activates it (by ABM) to bring the light through and blind the negative forces. It helps the Candidate go deeper into his or her self and get more benefit out of the ceremony. As a mere symbol, though, it still has quite an effect and helps counterbalance the Banner of the West, which is shown in Figure 29.

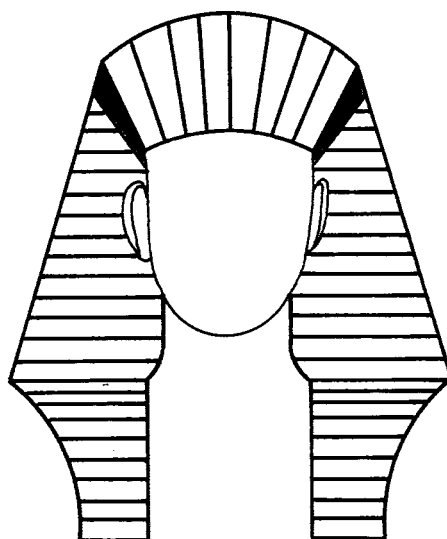

Figure 30
The Nemyss of the Hierophant (front view)

The red-and-white-striped nemyss worn by the Hierophant is colored in a mixture of the Divine Flame through the Divine White Brilliance, both an equal mixture (see Figures 30, 31, and 32). This covers the head of the Hierophant and the Kabbalistic Supernals (the three Sephiroth of Kether, Chokmah, and Binah) in man the Microcosm. The nemyss becomes the Hierophant's link with his/her Ruach to the Astral Shell of Horus and Aroueris that s/he has created. The covering of the Three Higher Sephiroth of Kether, Chokmah, and Binah prevents this activated shell from taking over totally the personality of the

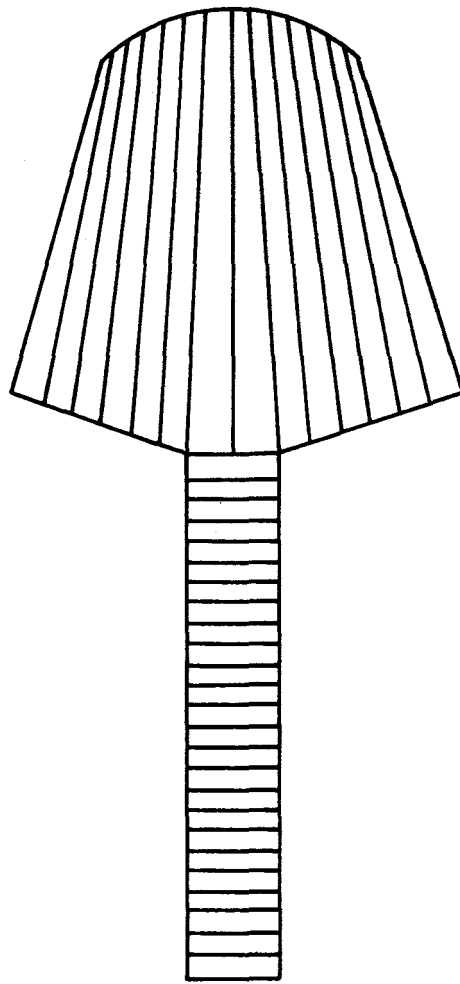

Figure 31
The Nemyss of the Hierophant (rear view)

Hierophant during god-form linkage, yet it does so without repelling it. Normally, this influx of energy would boost up the etheric centers to the point that the Hierophant's own chakras, on his/her back, would be linked directly to those of the god-form, but the nemyss prevents this. The long tail of the nemyss, which goes to just below the base of the spine and is wide enough to cover the chakra vortex, also acts as a type of protection against

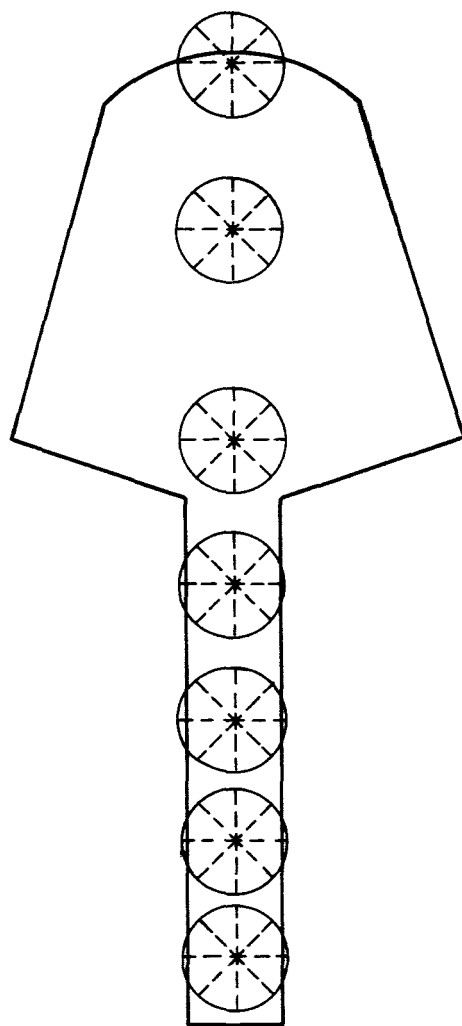

Figure 32
The Sephiroth on the Nemyss of the Hierophant

possession during the ceremony and prevents the kundalini from rising up this path.

Some Adepts, of both the Golden Dawn and the Stella Matutina, had a fear of possession so strong that they had talismans sown into the linings of their nemysses, at the bases of the tails, to prevent this. Though the Golden Dawn recognized

the Western Tradition, its members were still very much aware of the effect of the chskras. Felkin's notes show that this type of teaching was taught as early as 1897 to Golden Dawn Adepts.

When the god-forms link to the Hierophant, it is done at the front of the body and not the back, through the lamens, which also acts against possession through the Rose Cross symbols and has control over the Hierophant faculties. At Whare Ra the Hierophant's lamens was sometimes colored white instead of green, which, according to Taylor, helped keep the link to the astral god-form pure and prevented obsession better than green though still retaining its function while making the link and the god-form more powerful. The use of white or green on the lamens depended entirely on the Hierophant, and both were used for many years.

The Hierophant and the Current of Osiris

The Osirian Current in the Neophyte Ritual is represented in the Outer Order by the Hierophant. It is essentially a current of death and rebirth. The Osirian influence was one of the first major cultures to elevate man to god status. He was the ruler of all eternity. In ancient Egypt, Osiris's main center of worship was in Abydos (Upper Egypt).

Osiris was "Lord of Abydos" and "Lord of Tuat." The latter title refers to that place of limbo to which the dead go before they are judged. The description of this is shown in *The Book of the Dead*, in the "Coming Forth by Day" chapters. From this, it can be seen that the current of Osiris is initiatory. The various stops and lessons given by the Hierophant are the Golden Dawn version of the "Coming Forth by Day" chapters.

Within the ancient Heliopolitan system, Osiris was placed in a subordinate position to Ra, the Sun God. However, in the 0=0 ceremony, he is analogous to Ra, in much the same way as Christ was subordinate to his Father in Heaven. The Osirian influence, in the 0=0 ceremony, is like the "Book of Pylons" which was considered by Budge as a companion to the "Coming Forth by Day" chapters of *The Book of the Dead*.

The Osirian Current is used to establish a Portal or mini-

universe within the 0=0 ceremony. It is used to show the Higher Self, through a virtual mass attack on the psyche, during this ritual. Furthermore, it shows the "Way" or correct Path which should be taken. The Osirian Current also shows the reverence of magical secrets.

The solar influence of Osiris is one which is imitated in the circumambulation of the Candidate around the Altar. Here, it acts out the passage of the sun as seen from the Earth. The Higher Self of the Candidate unconsciously identifies with this and it solidifies the *kavanah* (intention) of the Candidate. The Divine Light of this circumambulation focuses the Candidate's energy of the Higher Self, in the macrocosmic sense, of the Solar System. The Higher Self then activates a similar current within the body of the Candidate. This phase of the Osirian Current is a form of realization of this current's existence within the Self, which then tries to imitate it. Also, the Osirian influence allows the Candidate to "wash himself clean," which, in Golden Dawn terms, relates to the consecration of the Candidate.

According to tradition, the body of Osiris was cut into 16 pieces. Each of his 16 parts relates to the Golden Dawn system of the 16 elemental subdivisions. These become parts of the body of the Candidate which are later purified in the four elemental grade rituals (after the 0=0).

Within the Neophyte Ceremony, we are given a glimpse of what will happen in the "Partaking of the Eucharist" when the four Elements on the altar (rose, light, wine, and bread and salt) are felt through the physical senses of the Candidate to give him or her a sense of unity.

The Osirian Current affects the Ruach of the Candidate during the 0=0. Though it does not, at this point, precipitate the linking with the Nephesh, it does bring about an awakening through one's individual unconscious desire—the impetus for linking with the Ruach that is brought about in the 5=6 ritual. The stimulation of the Osirian Current affects the Candidate through the faculties of the Ruach: memory, will, imagination, desire, and reason. All of these parts of the self are stimulated equally. This is the "balancing process of the 0=0," so often described by Golden

Dawn Adepti.

Praemonstrator

The Praemonstrator is the most senior officer on the Dais and represents Chesed and the Grade of 7=4. The actual word "praemonstrator" is from the Latin *praemonstrare*, "to show forth." This Chief teaches the members of the Outer Order, either personally or through appointed senior members. The office of the Praemonstrator may be identified by the following:

- (1) Throne
- (2) Mantle
- (3) Lamén
- (4) Scepter
- (5) Nemyss

The blue throne of the Praemonstrator is situated on the Path of Kaph. This Path passes through the Veil on the side of the Pillar of Mercy and, as such, relates to the title of "Intelligence of Conciliation." It is here that the passive energies must be balanced by the Praemonstrator; otherwise the receptivity would absorb too much of this type of energy. The power of Chesed must be formulated and directed by the Praemonstrator, who represents its influence below the Veil. The exaltation of consciousness that this energy represents is here given form. The throne is said to both absorb and conciliate into a governable mass or form.

The proper mantle of office of the Praemonstrator is the Bright Blue Robe of Water, representing the reflection of wisdom and knowledge of Chesed. The White Cross and Triangle represent the purification of the Outer Order by Water. The cross on the mantle of the Praemonstrator is actually a Pyramidal Cross, which is the cross of the elements representing the descent of the divine and angelic forces into the pyramid symbol (this sits above the triangle, representing the symbol of the Golden Dawn). This action relates to the Higher Forces working through an Elemental Symbolism. Beneath this cloth, the Praemonstrator wears a blue robe. The robe is shown in Figure 33.

The Praemonstrator may wear a lamén like that of the

Hierophant, but it is blue upon an orange field and it hangs from a blue collar. The link which the Praemonstrator forms to the god-form Isis is done through his Tiphareth center. The Rose Cross symbol tapers the power so that the link is formed through certain conditions. Its color attracts Isis, and the complimentary orange creates the flashing effect that will make the link on two distinct levels.

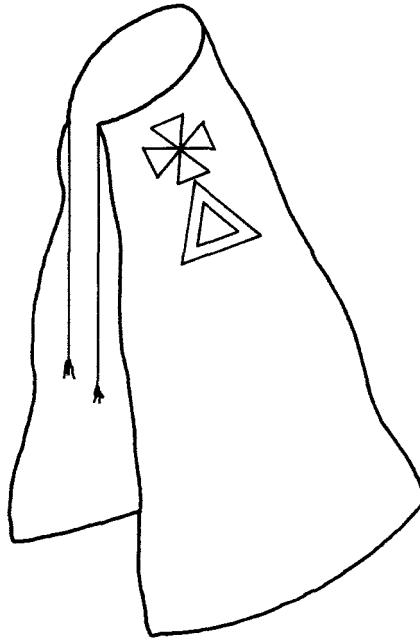

Figure 33
The Robe of the Praemonstrator

The scepter of the Praemonstrator has a blue shaft with a single gold band one quarter of the way up the shaft and one at its base (see Figure 34). Upon this is mounted a Maltese Cross in the colors of the Elemental Tablets, from North going clockwise: Yellow, Blue, Black, and Red. The first yellow band, on the base of the scepter, represents Malkuth. The next, Netzach, and the shaft above Netzach is Kaph. The rest of the shaft represents Qoph. The grip is on the Path of Kaph, which shows the influence

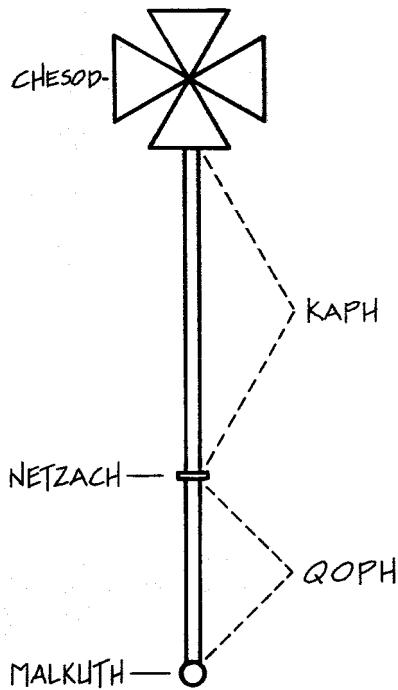

Figure 34
The Scepter of the Praemonstrator

above the Veil and represents the power of the "Wheel" and the cyclic nature of its existence. Since the power of this Office is above Malkuth, the lower grip is never used lest it interfere with the actions of the Hierophant. The Pyramidal Cross mounted on top of the scepter shows the elements consolidating the Water influence (with Earth, the densest element touching the shaft) so that it can be controlled and directed.

Since the Hierophant's Scepter works through Malkuth, the Praemonstrator's works through Netzach (from Kaph). The Scepter's use is mainly for receiving power from the Veil and to activate the Praemonstrator's Sphere of Chesed on the Dais. It also activates that of Netzach, which is the Pillar of Mercy on the Temple Floor, and keeps the power flowing through so that the temple is properly balanced.

(5) The nemyss of the Praemonstrator is Blue with complementary orange stripes. The function of this is the same as the Hierophant's nemyss, save that the colors represent the blue of water balanced with its flashing color from the astral plane.

The Praemonstrator and the Current of Isis

The Current of Isis is activated by the Praemonstrator. On the floor of the Temple, her influence is in the shape of the Pillar of Mercy, in the station of Netzach. Isis was the epitome of motherhood to the ancient Egyptians. She was the sister/wife of Osiris. She used her magical formula to give life to her dead husband. Her function was to prepare the way for her deceased husband through prayer. Apart from her general functions, Isis's specialty was vibration. It was she who said the words to rescue Osiris and bring him back to life. Isis represents Wisdom and Knowledge, which are given out in the speeches of the Temple officers during the 0=0 ceremony.

Within the Neophyte ceremony, the energies of Isis are Jupiterian by nature. She instills in the Candidate the cause of his own ignorance of the Sacred Mysteries. In this, she gives him direction and motivation. This relates directly to soul growth and provides the attunement to the Candidate's Ruach to blend in with the other energies directed down during the ceremony. Her function is to bind together, with the Candidate, the energy of the group Soul of the Order. She does this by linking the Ruach of the Candidate within the Ruach of the ritual, so that the macrocosmic plan gradually starts to be revealed to him.

The particular faculty she works through, in the Candidate, is memory—the most binding factor associated to the Ruach. She imprints on the unconscious mind of the Candidate the key points of the ceremony that will prepare him for the next level. The Isis Current allows the Candidate's Ruach to have access to the occult symbology of the Universal Unconscious, for Isis makes the Candidate "feel" part of the Order. It is her duty to link together all of the basic 0=0 ceremonies into a cohesive labyrinth that adds to the foundation of the basic Order itself.

The Isis Current acts to make the individual lose the quality of

the "I" for the "we" to participate in the overall plan. She is also the instigator to unleash the Candidate's "creative abilities" within the Order framework.

The Egyptian *Book of the Dead* says of Isis: "O Isis, Thou Goddess, Thou glorious one, who hast knowledge how to use Thy mouth." This specifically relates to the intent and aspirations of the invocation. She must supply each of the officers on the Temple floor with enough of this type of energy to reach deep within themselves so that they can give true statements; i.e., statements which are both meant and felt, and not merely read as empty words. In other terms, she helps the officers achieve the correct vibrational pitch so that all may act in unison and with fervor when speaking during the ceremony. When word fumbles occur during speeches in this ritual, then the Isis Current is not manifesting correctly.

The Isis energy also assists with the consecration of both the Temple and the Candidate. She re-enforces the Current of Osiris in that function. Also, it is she who instills the solemnity of the occasion when the Candidate is stopped and questioned during the ritual. It is also through her efforts that the Candidate is allowed to pass on to the next point.

Within the Golden Dawn, Stella Matutina, and Smaragdum Thalasses, the words "dead air" are used to refer to a ritual when nothing seemed to happen. This relates directly back to the duties of the Praemonstrator whose function it is to activate and outwardly direct the Current of Isis during ritual. When this Officer is not performing his function correctly, "dead air" creeps into the ritual. To direct and use the Isis Current requires a great deal of work from the Praemonstrator, for he or she must reinforce the Hierophant at all times (through the Ruach).

Imperator

The Imperator is the Chief who holds the IMPERIUM, the rule, command, or charge over the Outer Order. It is s/he who is in charge of the Temple. S/he conducts the ceremonies and is responsible for the general discipline of the Order. The Imperator relates to the Sephira of Geburah, the god-form of Horus, and the

rank of 6=5 within the Order. This officer may be identified by the following:

- (1) Throne
- (2) Mantle, robe
- (3) Lamén
- (4) Sword
- (5) Nemyss

The red throne of the Emperor sits on the Path of Mem, has the title of "Stable Intelligence," and relates to growth through a given framework. His or her position is at the far left of the Temple. As such, it represents the Pillar of Severity, which directly relates to the martial qualities of masculine force. It is here that one comes through the suffering of Spiritual Initiation—the first step on the path to illumination. This path is the opposite of Kaph, as here one is virtually on trial—while in Kaph one transcended this state. The Emperor's Throne is the place where one's competence is tested.

The mantle of the Emperor is a flame-scarlet robe—the cloak of Fire and Severity. The energy and stability of the Temple depend on the Emperor (see Figure 35). The cloak and robe are the symbols of unflinching Authority, compelling the obedience of the Temple to all commands issued by the Second Order. Upon the left breast of the robe is the Maltese Cross above a triangle. The Maltese Cross of four arrowheads represents the keen and swift impact of the Light coming from behind the Veil.

The lamén of the Emperor is similar to that of the Hierophant (and performs the same functions) save it is hung from a green collar. This shows that s/he takes a commanding, but passive, role compared to that of the Hierophant.

The sword of the Emperor has a red grip with a gold guard (see Figure 36). The grip represents the Path of Shin, while the gold is Tiphareth, and the blade is Mem with Geburah as the tip. Wielding from the power of Shin shows the power of "Perpetual Intelligence," for this is a weapon used blade-on only. The Emperor sits with the sword partly turned so the edge of the blade faces towards the Temple. It acts as a warning to any

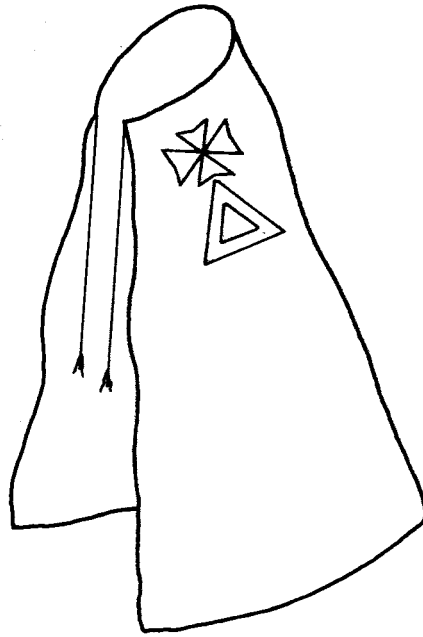

Figure 35
The Robe of the Imperator

elemental or higher force that this is the Sword of Judgment that will inflict retribution on anything that interferes with the ceremony.

The nemyss is red with green stripes and has a similar function to that of the Hierophant.

The Imperator and the Current of Nephthys (or Nephthys)

On the Dais, the goddess Nephthys is represented by the Imperator and, on the Temple floor, by the Black Pillar in the Station of Hod. In Egyptian mythology, Nephthys was the sister to both Isis and Osiris and was considered by many as the shadow of Isis, always in the background—ready to be counted on if needed. It was Nephthys who helped Isis reconstruct the body of Osiris. It was she who was instrumental in helping Horus after he was stung by the scorpion. Her main centers of worship were at Senu, Hebet, Per-mert, and Re-nefert. Her functions are described in

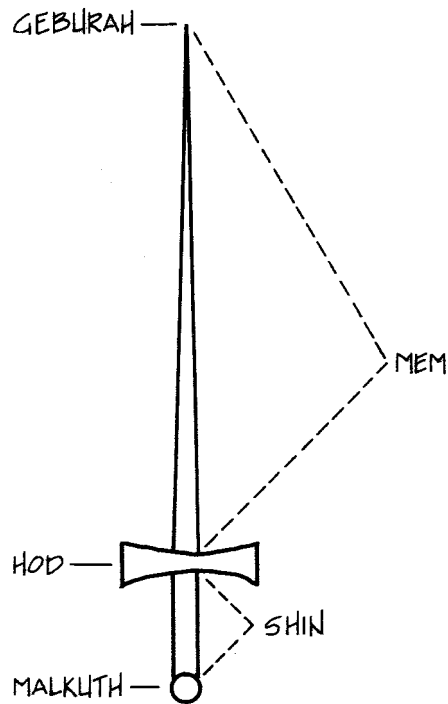

Figure 36
The Sword of the Emperor

The Book of the Dead, where she says, "I go round behind Osiris. I have come that I may protect Thee, and my strength which protecteth shall be behind Thee forever." Nephthys was considered the extremity of things—which referred namely to boundaries. She was also associated with death and rebirth.

The function of Nephthys in the 0=0 ceremony is to stabilize the currents from North to South and East to West. As such, it has an influence on the Altar, the point where all these meet. She also has control of the Canopic Gods (or Four Children of Horus, as they are sometimes called) situated at each corner of the temple. With the Emperor as the tool, Nephthys's current is one of power, in working at the Altar, in which she assists the Osirian Current. While initiating a current in the Temple is one thing, maintaining it is yet another. To balance these currents in an even flow is

the responsibility of the Imperator and the Current of Nepthys.

During the 0=0 ceremony, when the Higher Self of the Neophyte is placed between the Pillars, it is the function of the Nepthys Current to hold it, or bind it to this position, so that it does not wander off during the ritual. If Nepthys were to relax her vigilance, Typhon would then try to seize the Ruach of the Neophyte. Every position of every god-form owes its stability to the Current of Nepthys. If she were not present, the Portal, or boundary of the ritual, would be opened. One of the major functions of Nepthys is to contain the limits of the Portal during the ceremony. She accomplishes this through the Imperator. She binds the god-forms so they remain in their correct stations through the power emanating from the Altar and the Osirian Current.

When the god-forms move around the Temple floor, Nepthys has to maintain the correct balance of energy which she works through the Pillars. It is Nepthys who holds and conceals the Ruach of the Neophyte from Typhon in the place of Harpocrates. When Typhon tries to move out, Nepthys assists Horus/Aroueris to keep him at bay. When the Neophyte enters the Temple, it is Nepthys who keeps him from straying from the allotted path during the ritual. In the final part of the ceremony, when members partake in the Eucharist to help ground the varying energies into their auras, the Nepthys Current is responsible for seeing that no negative energies are taken in with the good.

It is the duty of the Nepthys Current to prevent any negative influence on the ability of the Imperator to create and assume a god-form. If this is not done properly, the Portal remains weak and can be penetrated. At the conclusion of the ceremony, it is she who must dissolve the Portal and any forms in it and ensure that no trace of residue remains.

Cancellarius

The Cancellarius is the officer who represents the Sphere of Tiphareth. The actual etymology of the word *cancellarius* is derived from the (late) Latin word meaning "porter," "doorkeeper," or "secretary." It is the origin of the English word

"chancellor," originally an usher in a law court, then a keeper of the records, a secretary (in which sense it is used in Shakespeare). In later years, this word referred specifically to the king's secretary, the officer to whom petitions for the mitigation of the rigor of the common law were referred. He became the "Keeper of the King's Conscience" and acquired judicial functions which developed into the Court of Chancery. Until about the end of the 16th century, he was an ecclesiastic; afterwards, a lawyer.

The generally accepted derivation of his name is from the position of his seat near the *cancelli* or lattice-work partition surrounding the Judgment Seat. Others have suggested that it is derived (like the word "cancel") from crossing out words with a lattice-like line. The Roman numeral X, for "ten," originated in the practice of crossing every tenth stroke, the upper half of the X being taken to represent half of this, the Roman V, which stands for "five."

In the Order, the Cancellarius is the Secretary of the Temple who keeps the Roll of Membership, who is in charge of and issues the manuscripts, and who keeps a record of the progress of every member. In the event of resignation or expulsion of a member, the Cancellarius cancels his name in the official records of the Temple. He is more immediately than either of the proceeding Chiefs the Representative of the executive authority of the Second Order over the Outer. The Cancellarius is identified by the following:

- (1) Throne
- (2) Mantle and robe
- (3) Lamén
- (4) Scepter
- (5) Nemyss

The yellow-gold throne of the Cancellarius represents the Sephirah of Tiphareth and sits on the Path of Samekh, which leads to Yesod, the Sephiroth of Air.

The mantle and robe of the Cancellarius are colored in the yellow gold of Air and the Sephirah of Tiphareth (*see* Figure 37).

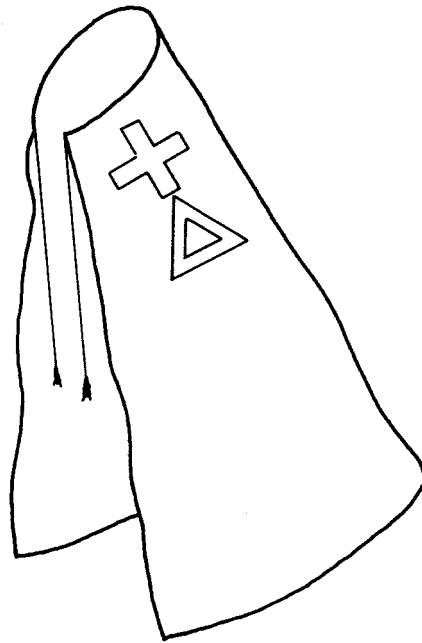

Figure 37
The Robe of the Cancellarius

The White Cross (situated above the triangle) on the mantle is an equilateral one which represents the Cross of the Elements and symbolizes their purification through the Light of the four-lettered name, YHVH, in Tiphareth. The Cross above the Triangle relates to the purification of the Outer Order by Air.

The Cancellarius wears a lamén like that of the Hierophant, but of yellow on a purple field and hanging from a purple collar. The function of this is exactly the same as the lamén of the other officers on the Dais.

The scepter of the Cancellarius is surmounted by a hexagram of amber and gold (see Figure 38). The hexagram relates to Tiphareth, the main shaft of the scepter to Samekh, the white ring above the grip to Yesod, the grip to Resh, and the pommel to Malkuth. By working through the path of Resh, through Yesod, the Cancellarius is able to use the solar energy by bringing through the Divine Light of Thoth the Enterer, without whom no

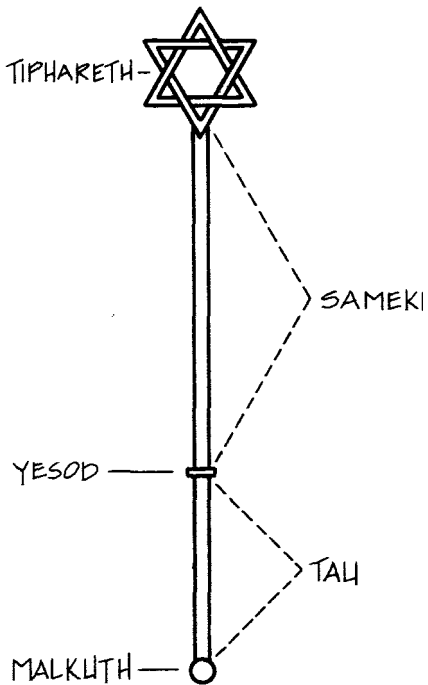

Figure 38
The Scepter of the Cancellarius

connection to the Second Order can be made.

(5) The nemyss is gold with mauve or purple stripes and has the same function as that of other nemysses.

The Cancellarius and the Current of Thoth

The god-form of Thoth is represented by the Cancellarius on the Dais. Thoth was always considered the Scribe of the Gods. It was on his records that the fate of the deceased depended. Thoth was self-created. He taught the sciences and gave the world divine speech. It is said that his name was derived from the word "weight." In ancient Egypt, his main center of worship was in Khemennu.

Within the 0=0 ritual, Thoth holds a very unique position, for he is the personal representative of the Second Order. It is he

that makes sure that the Current of Thoth (from the Second Order) is given to the right person. Also, it is he who makes judgment if this current is to be instilled in the Candidate. All the invocations in the world will not work unless the god-form of Thoth is formulated correctly by the Cancellarius so that the powers may find the correct resting place. It is he who must judge the past performance of the Candidate before admittance to the Order.

If the Candidate is considered unsuitable by this god-form, then the energy impregnated into his aura is merely nothing but residue of the ritual's other currents. If the individual going through the 0=0 is found unsuitable by Thoth, then any future gestures will only produce some psychological effect (this includes Inner Order positions as well). Thoth is representative of the Inner Order, while the Hierophant merely acts on their behalf. Thoth must be correctly formulated and his energies directed at the Candidate by the actions of the Ruach of the Cancellarius, for without this the ritual cannot function.

Past Hierophant

The duties of the Past Hierophant, or Previous Hierophant, in the 0=0 ceremony is mainly one of a support role. S/he wears the same costume as the Hierophant (in some Temples the Past Hierophant wears a pure scarlet nemyss to distinguish his/her office from that of the Hierophant). S/he usually carries the Hierophant's scepter while the new Hierophant is "learning the ropes." S/he is there to support and train the new Hierophant and, if the former makes an error in judgment, to step in and help. S/he may, from time to time, give some advice to the Hierophant during the ritual as well. When the Hierophant leaves the Dais to work on the Temple floor, the Past Hierophant then assumes the vacant slot and takes over during the Hierophant's absence.

The Past Hierophant and the Current of Aroueris

The god-form of Aroueris in its Golden Dawn context represents Horus the Elder. He was analogous to the "Light of the



Adepts of the Ra Horakhty Temple in ceremonial dress



Beginning of the Sign of the Enterer
(demonstrated by Frater M.L.)



The Sign of the Enterer



The Sign of Silence



*Hiereus, Hierophant, and Hegemon:
The Officers of the Middle Pillar*



The Hegemon, Hierews, and Hierophant hold their weapons over the head of the Candidate following her acceptance into the Order

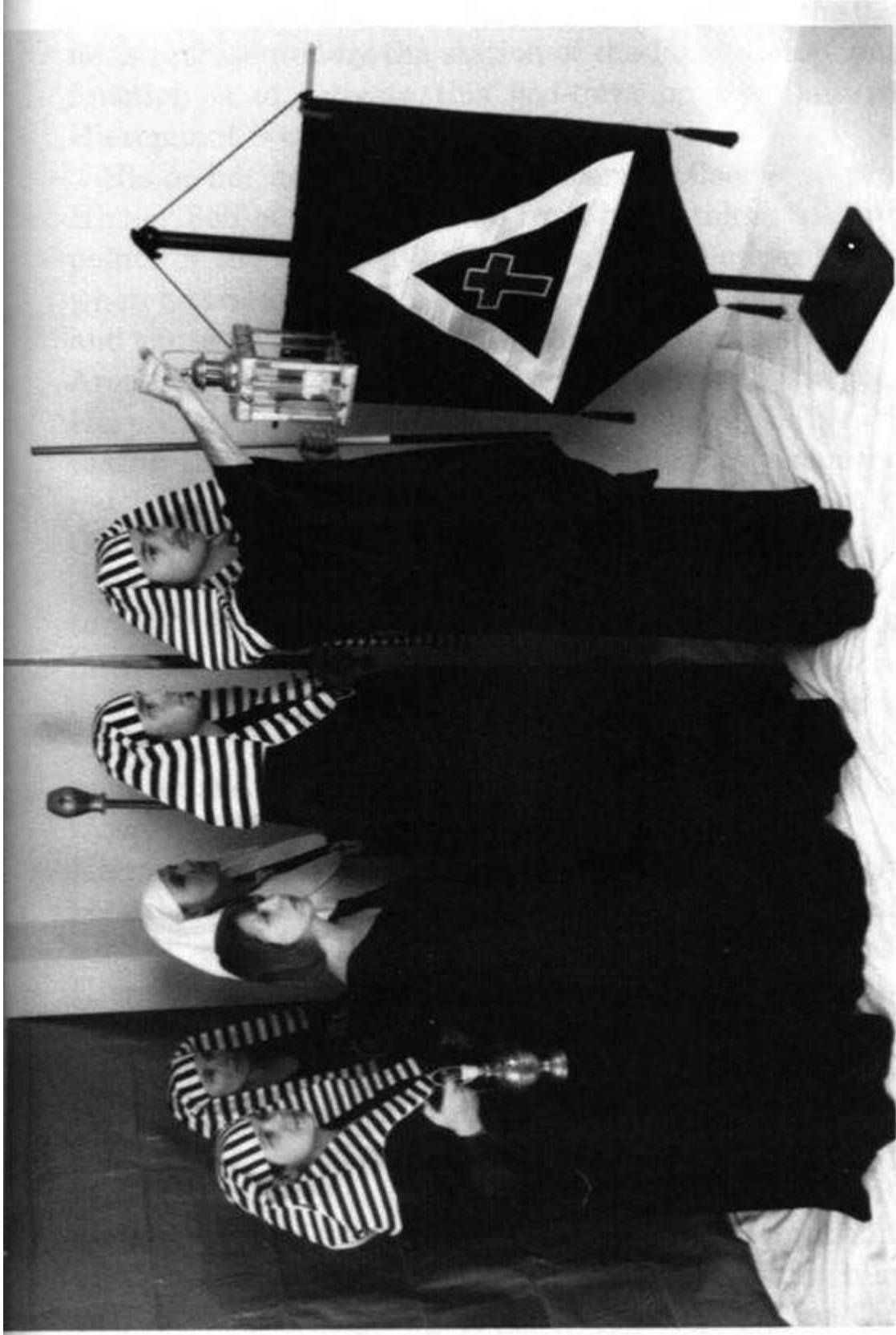

*The Kerux, with lamp, leads the circumambulation
past the Banner of the West.*

Day," the one who fought Set (as Night). His seat of power in ancient Egypt was at Makenut and Sakhemat. In the O=O ritual, he is represented by the station of the Past Hierophant, whose function is to activate this god-form on the Dais when the Hierophant is on the Temple floor.

His or her actual duty on the Temple floor is to protect the Higher Self of the Candidate from being taken over at critical points of the ceremony. S/he faces his old adversary, Typhon, when he tries to leave his station of the Evil One to do damage and cause havoc in the ritual. This type of protective duty that Aroueris performs is also shared slightly with the god-form of Harpocrates, whose Invisible Station prevents the Evil One from taking the power of the Circumambulation. Aroueris is very much the guardian on the floor and protects not only the Candidate but the Officers as well.

While s/he functions on the Temple floor, Aroueris has the duty to control the power or current which the Hierophant has initiated in the East as well. S/he does not actually create this current, but guards it to make sure that it functions correctly. In modern terms, his/her duty on the Dais is like that of a maintenance man; while on the floor, he is a type of shock trooper. While the Current of Aroueris comes from the Hierophant's Throne, Aroueris' astral form gives it an additional boost both in strength and direction. The Past Hierophant must control the power from his/her own station (beside the Hierophant) through his/her Ruach which is linked to the Ruach of the ceremony itself. When the Hierophant uses the power on the Temple floor, it is through the form of Aroueris on the Dais, and the astral form of Aroueris then envelopes him/her.

Because of Aroueris' martial-like position on the Temple floor, his/her position of power in the O=O is one of extremes. From one viewpoint, s/he upholds the power of the Hierophant and, in other areas, s/he treads on Typhon, thus containing him. S/he is very much the warring priest combination. The Current of Aroueris is one of sudden transformations and changes. It is one that takes the subtle centers of the Candidate to the limit of his or her abilities (within the O=O terms of reference) and it also speeds

up the vibration of the Candidate so that s/he can assimilate the data, that is received more rapidly in a complete upheaval by a revolutionary attitude. The Candidate then becomes the focal point for Universal Consciousness of the Order to flow into. If this touch by Aroueris is not reciprocated by the Candidate s/he will simply withdraw it. It is then that s/he implants a radical sense of change in the Candidate through the Ruach.

Hiereus

The Station of the Hiereus is at the extreme West of the Temple and the lowest point of Malkuth, where s/he is enthroned in its darkest part in the quarter represented black in the figure of the Minutum Mundum. Representing a terrible and avenging god at the confines of matter, at the borders of the Qlippoth, s/he is enthroned upon matter and robed in Darkness, and about his/her feet are thunder and lightning—the impact of the Paths of Shin and Qoph, Fire and Water, terminating respectively in the russet and olive quarters of Malkuth. There, therefore, is s/he placed as a mighty and avenging guardian to the Sacred Mysteries. The symbols and insignia of Hiereus are:

- (1) The Throne of the West in the black of Malkuth, where it borders on the Kingdom of Shells.
- (2) The Black Robe of Darkness, bearing a White Cross on the left breast.
- (3) The Sword of Strength and Severity.
- (4) The lamén suspended from a scarlet collar.
- (5) The Banner of the West.

Note: The nemysses of the officers on the floor are black with white stripes, the exception being the Hegemon, whose nemyss is pure white. These perform the same functions as the nemysses of the Officers on the Dais.

The position of the Throne of the West, at the Limits of Malkuth, is fitting for the Avenger of the Gods, for s/he is placed there in eternal affirmation against the Evil One—"Hitherto shall ye come and no further." The Throne is also placed there as a seat of witness and of punishment decreed against Evil.

Basically, the Throne has two functions: to prevent the Qliphoth from entering and to prevent anyone lingering outside this area from entering through curiosity.

The position of the Throne is the easiest access for any negative traits—for this is the area where the Sun, or Light of Day, sinks into oblivion. The Throne of the Hieres contains this by keeping the forces of Light (directly from the Hierophant) focused on the locked gateway of the West.

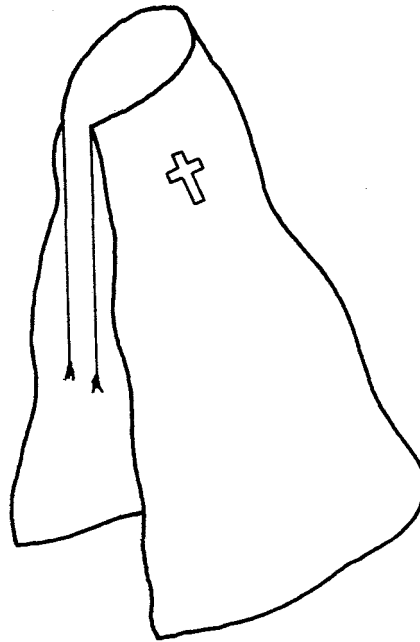
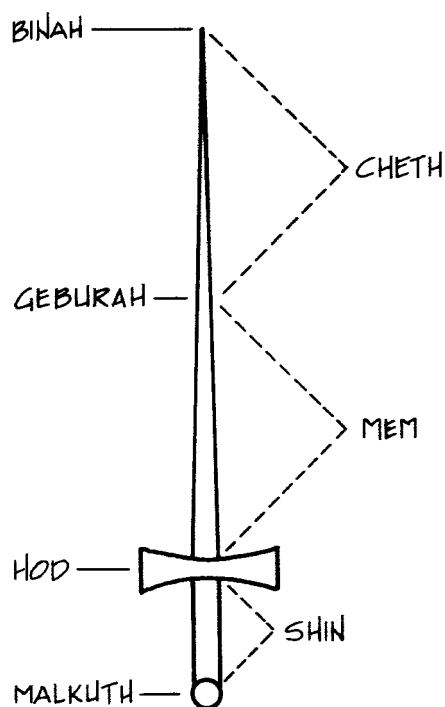

Figure 39
The Robe of the Hieres

The robe and mantle of the Hieres symbolize Darkness, threatening and terrible to the Outer, as concealing an avenging force ever ready to break forth against the Evil Ones (see Figure 39). On the left breast is a White Cross to represent the Purification of Matter unto the Light. Taylor always taught that, though the robe and mantle were the same color, they worked on different principles. The mantle or cloak was the active part of

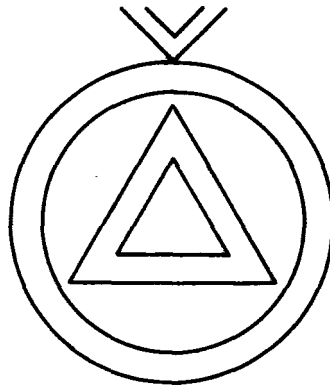

*Figure 40
The Sword of the Hieres*

the Hieres while the robe, like those of all the officers on the Temple floor (save Hegemon), was black because of its absorption principle. The black restricts the growth of negativity, which bogs it down by condensing it. Before any negativity can work on the Temple Officers, it must try to take over the god-form the officer represents, and the black robe prevents this by absorbing all its energy and restricting it—which is usually held in check by the god-form above it. Though not an Earth Grade, the robes of the Temple Officers draw from the densest part of Malkuth for their strength. Taylor likened the principle to being caught in a bog with no escape for any negative force that did not manage to penetrate the Portal of the Temple. There are of course checks and counterchecks with the various other energies, so that there are overlapping safety factors should one or more forces fail to

uphold their function of protection during the ritual.

The sword represents the forces of the Pillar of Severity as a whole (see Figure 40). The guard represents Hod and is usually made of brass; the grip is the Path of Shin which represents the Universe governed by the flaming forces of Severity and which represents Hierus as wielding the forces of Divine Severity. "The Sword of Vengeance is its Name." The blade shows this concept from Hod to Binah, encompassing Geburah through the paths of Mem and Cheth.



*Figure 41
The Lamen of the Hierus*

The lamen (shown in Figure 41) is particularly explained in the Portal Ceremony:

The Outer Circle includes the four Sephiroth, Tiphareth, Netzach, Hod, and Yesod, of which the first three mark the angles of the triangle inscribed within, while the connecting Paths Nun, Ayin, and Peh form its sides. In the extreme center is the Path Samekh through which is the passage for the Rending of the Veil. It is therefore a fitting Lamen for Hierus as representing the connecting link between the First and Second Orders, while the white triangle established in the surrounding Darkness is circumscribed in its turn by the Circle of Light.

In addition to this explanation, the lamén represents "The Light that shineth in Darkness though the darkness comprehendeth it not." It affirms the possible Redemption from Evil, and even that of Evil itself, through self-sacrifices. It is suspended from a scarlet collar as representing its dependence on the Forces of Divine Severity, over-awing the evil. It is a symbol of tremendous Strength and Fortitude, and it is a synthesis of the Office of the Hieréus, as regards the Temple, as opposed to his

Office as regards the Outer World. For these reasons, it should always be worn by the Hieréus.

The Banner of the West (see Figure 29, page 84) completes the symbols of Hieréus. It is thus explained in the Zelator Grade:

The White Triangle refers to the three Paths connecting Malkuth with the other Sephiroth; while the red cross is the Hidden Knowledge of the Divine Nature which is to be obtained through their aid. The Cross and Triangle together represent Life and Light.

In addition to this explanation from the Zelator Grade, it represents eternally the possibility of Rescuing the Evil; but, in it, the Tiphareth cross is placed within the White Triangle of the Supernals as thereby representing the sacrifice as made only unto the Higher. The Red Cross may be bordered with gold, in this instance, to represent the perfect metal obtained in and through the Darkness of Putrefaction. Black is its field, which thus represents the Darkness and Ignorance of the Outer, while the White Triangle is again the Light which shineth in the Darkness but which is not understood. Therefore is the Banner of the West the symbol of Twilight—as it were the equation of Light and Darkness. The pole and base are black, to represent that even in the depths of Evil can that symbol stand. The cord is black, but the transverse bar and lance-point may be golden or

brass and the tassels scarlet, as in the case of the Banner of the East and for the same reasons.

The Banner of the West, when it changes its position in the Temple, represents that which bars and threatens and demands (a symbolic) fresh sacrifice so that the path leading to the Higher

can be attained. "Avenger of the Gods" is the name of Hiereus, and s/he is "Horus in the Abode of Blindness unto, and ignorance of, the Higher." Hoor is his name.

Hegemon

The Hegemon is one of the three Chief Officers of the Temple. S/he comes without the Portal and instructs the Candidate to hold him/herself in readiness for the Ceremony of Admission—and also superintends his/her preparation for this by the Sentinel. The name of this Officer is simply a translation from the Greek which means "a leader" or "guide"—"one who has authority over others," and "one who shows the way", "a person who does something first"—"a Commander." It is also found with feminine adjectives from very early times. If we take the verb *ago* from the root AG it means "to carry," "to convey," and "to bring" (mostly with living creatures and objects), "to take with one," "to lead." Also this word relates to "train" or "educate" and to "weigh in a balance." In its adjectival form, *ho hegemonios* has a meaning of guiding and was an epithet of Hermes as the Guide of the Departed Souls (in which capacity this God was known as *Pompaios* or *Psychopompos*). As one can see, its etymological base is highly complex—the guiding of living creatures towards a desired object, at the same time training and weighing it in the balance.

The Station of the Hegemon is between the two Pillars whose bases—are in Nezach and Hod, at the intersection of the Paths of Peh and Samekh in the symbolic gateway of Occult Sciences—as it were, at the Base of Balance, at the Equilibrium of the Scales of Justice, at the point of intersection of the lowest reciprocal Path with that of Samekh, which forms part of the Middle Pillar.

This is one position where the feminine, passive energies are usually handled better by a woman than a man. At Whare Ra, this position was usually taken by a woman, and I believe it was the same in the Golden Dawn. S/he is placed there as the Guardian of the Threshold of Entrance and the Preparer of the Way of the Enterer—therefore the reconciler between the Light and Darkness and the mediator between the Stations of the

Hierophant and the Hiereus.

The Hegemon has in fact three Coptic forms: 1. Thma-As-St (as regards the Middle Pillar and the influence from Kether), 2. Thma-aesh (her more Fiery influence related to the Pillar of Severity), and 3. Thmaa-ett (more Fluidic with regard to her influence with respect to the Pillar of Mercy). The symbols and insignia of the Hegemon are:

- (1) The robe, nemyss and Mantle of Pure Whiteness, bearing on the left breast a Red Cross.
- (2) The miter-headed scepter
- (3) The lamén suspended from a black collar.

The robe, nemyss, and mantle represent the color of spiritual purity which is required in the aspirant to the Mysteries and without which qualification none can pass between the Eternal Pillars. It represents the Divine Light which is attracted thereby and brought to the aid • of the Candidate. It symbolizes the self-sacrifice that is offered for another—to aid him in the attainment of the Light. It also signifies the atonement of error, the Preparer of the Pathway unto the Divine. Upon the left breast is a Cross, usually the Calvary Cross, red to represent the energy of the lower Will purified and subjected to that which is Higher—and thus is the Office of Hegemon especially that of the Reconciler.

The miter-headed scepter (see Figure 42) is the distinctive ensign of the Office of Hegemon. On the Tree of Life, it represents the forces of the Pillar of Mercy. It should be of scarlet with gold bands and a pommel. The two bands represent Chesed and Netzach—the shaft being formed by the Paths of Vau, Kaph, and Qoph, the grip with the pommel in Malkuth. The miter is gold with red mountings, and each point terminates in a ball. The miter is charged with a red Calvary Cross of six squares. This miter represents the wisdom of Chokmah as a duplicated aspect of Kether, attracted by the symbol of self-sacrifice. The scepter is wielded by the forces of Flux and Reflux, shown by the grip being referred to the Path of Qoph, and it represents the attraction into the Universe of the Forces of Divine Mercy. The Sephiroth and

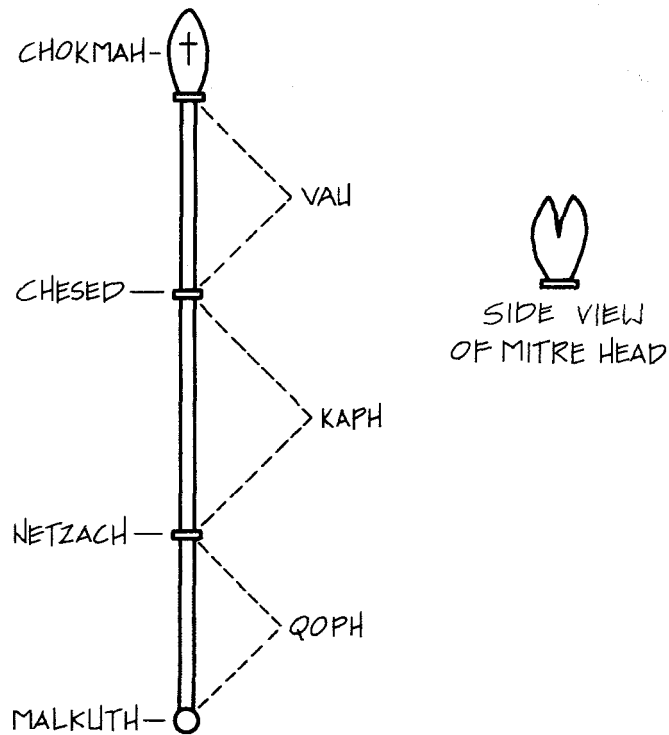

Figure 42
The Scepter of the Hegemon

Paths are marked only as bands and, owing to its meaning, should be carried by Hegemon in all conducting of the Candidate as representing to the latter the attraction of the forces of his Higher Self. It is called the "Scepter of Wisdom." Since the Hegemon is the wielder of the Scepter of Dual Wisdom from Chokmah, the miter-head is split in two and not closed, to indicate the Dual Manifestation of Wisdom and Truth — even as the Hall of the Neophyte is called "The Hall of the Dual Manifestation of the Goddess of Truth."

The lamen of the Hegemon (see Figure 43) is explained in part in the Grade of Philosophus:

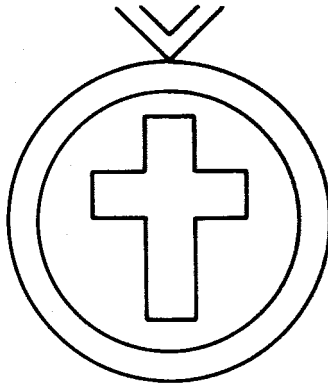

Figure 43
● *The Lamens of the Hegemon*

The peculiar emblem of the Hegemon is the Calvary Cross of Six Squares within a Circle. This Cross embraces Tiphareth, Netzach, Hod, and Yesod, and rests upon Malkuth. Also the Calvary Cross of Six Squares forms the cube and is thus referred to the Six Sephiroth of Microprosopus which are Chesed, Geburah, Tiphareth, Hod, and Yesod.

In addition to this explanation, it represents the black Calvary Cross of Suffering, as the Initiator by Trial and Self- Abnegation and the Opener of the Way into Comprehension of the Forces of the Divine Light. It is, therefore, suspended from a black collar to show that suffering is in the Purgation of Evil.

The next three inferior officers do not wear cloaks or mantles, but only lamens suspended from black collars. The designs are in white on a black field to show that they are Administrators of the Forces of Light acting through the darkness, under the Presidency of the Superior Officers.

Kerux

The Kerux is stationed within the Portal of the Hall, and his duties are to see that the furniture of the Hall is properly arranged before the opening and to guard the Inner Side of the Portal. The symbolism of this officer will, as in the case of the others, gradually unfold itself to the Neophyte as s/he passes

from grade to grade. Also s/he admits the Fratres and Sorores and assists in the reception of the Candidate at the command of the Hierophant, whose Herald or Messenger s/he is. The Greek word *kerux* means "a Herald," "Pursuivant" or "Public messenger," and was equivalent to the Latin word *caduceator* (bearer of the Caduceus), for Hermes was a Herald of the Gods. Their function in ancient Greece was to summon the Assembly (Gr. *ecclesia*), which was originally political and only later became a religious assembly or church) and keep order therein. They had charge of the arrangements at sacrifices and carried wands of office (*skeptron*, from which came "scepter," or *kerukeion*, the latter being usually like the Caduceus). Their persons were sacred and under the protection of Zeus, and they also were messengers between enemies in war. The verb *kerusso* meant "to officiate as a Herald," hence, "to proclaim" (in various senses—e.g., of news of a person's name as a criminal, as winner of a contest, etc.), to summon a person, and then to invoke the Gods or spiritual powers. The Kerux of the Order wears on his/her breast a lamén (from the Latin *lamina*, "a plate" or "thin piece of metal") on which is depicted the Caduceus of Hermes, which relates back to its original Greek meaning. The Kerux is the Herald, the Guardian and Watcher within the temple, as Sentinel is Watcher without—and therefore in his/her charge is the proper disposition of the furniture and stations of the temple. S/he is also the proclaimer. The peculiar ensigns of office are:

- (1) Red Lamp
- (2) Staff
- (3) Lamén

The Red Lamp signifies the Hidden Fire over which s/he watches. The lamp also represents the center of the Ruach, Tiphareth, which the Neophyte aspires to unite with so that the Hidden Knowledge beyond the veil can be revealed.

The Magic Staff of Power (see Figure 44) represents a ray of the Divine Light which kindles the Hidden Fire. In its Outer Order form, this small (un-winged) staff resembles a teacher's pointer and is colored in the three colors (from the top to the point) red,

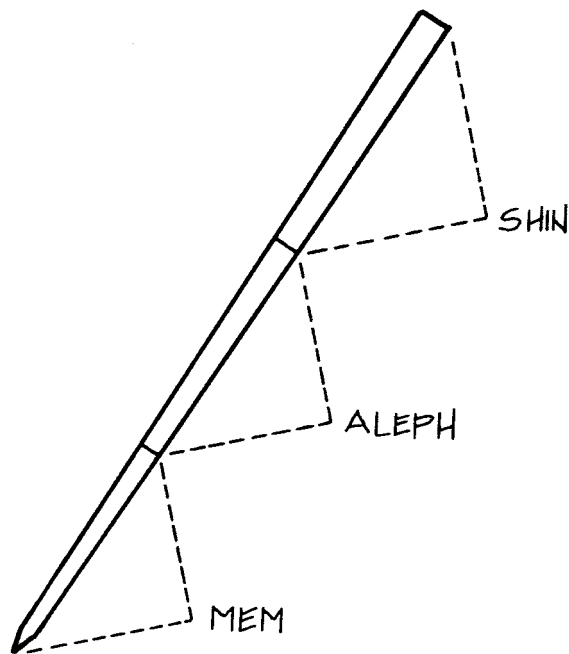

Figure 44
The Staff of the Kerux

yellow, and blue, which represent the three Mother Letters. In its Inner Order form, this is the Wand of the Chief Adept and is then shown as a Winged Caduceus, for placed on the Tree of Life the upper wings touch Chokmah and Binah—the three Supernals. The seven lower Sephiroth are embraced by the twin serpents whose heads rest upon Chesed and Geburah. When wielded by the Kerux, the staff is gripped in the yellow color of Aleph and its association to Air, which is analogous to the Kerux's nature.

The lamen of the Kerux (see Figure 45) has on it the symbol of the Winged Caduceus (whose historical significance has been already explained), whose wings symbolize the transcendence or rising of the spirit, while the double serpent shows the dualism of opposites which the Neophyte has to overcome, for the serpent is the obstacle of man. For it is here in the 0=0 that the Kerux must

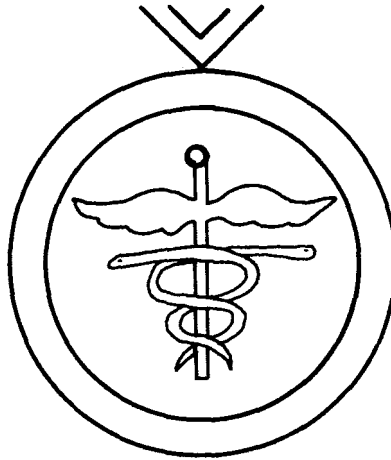

Figure 45
The Lamén of the Kerux

guide the Neophyte through the Mystical Circumambulation past the various guards, checks, and balances contained therein.

Stolistes

The Stolistes is the one who equips or clothes, and is a late Greek word equivalent to *hierostolos*—an Egyptian Priest who had charge of the sacred vestments. Neither form of this word is found in the Classical Greek period or in connection with Greek Mysteries. Both belong to the first century A.D. The verb *styello*, and its derivative *stolizo*, mean "to put in train," "to equip," or "dress." *Stolis* signifies "a garment" or "robe," while *stole* (from the same root) means "to equip" or "fit out with clothes" (originally "an army"), hence, "a garment" or "robe." This is the origin of the English word "stole," in the sense of an ecclesiastical vestment (compare with the German word *Bestellen*), though the word *stolisterion* was the vestry of a temple.

The Stolistes is stationed in the northern part of the Hall, to the northwest of the Black Pillar, whose base is in Hod. It is there as an Affirmer of the Powers of Moisture or Water reflected through the Tree into Hod. This office is identified by the following insignia:

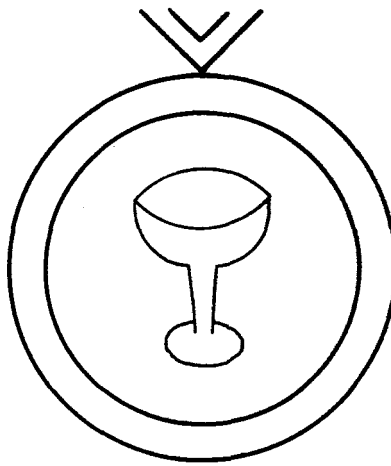

Figure 46
The Lamen of Stolistes

(1) Cup

(2) Lamen

The cup is the receptacle filled with the Water from Hod so as to transmit its forces into Malkuth, restoring and purifying the vital forces therein by cold and moisture (see Figure 46). "Goddess of the Scale of the Balance at the Black Pillar" is the name, and she is "The Light Shining through the Waters of the Earth." In the 3=8 grade it says:

The Cup of Stolistes partakes in part of the Symbolism of the Laver of Moses and the Sea of Solomon. On the Tree of Life, it embraces nine of the Sephiroth, exclusive of Kether. Yesod and Malkuth form the triangle below, the former the apex, the latter the base. Like the Caduceus, it further represents the Three Elements of Water, Air, and Fire. The Crescent is the Water which is above the Firmament, the Circle is the Firmament, and the Triangle the consuming Fire below, which is opposed to the Celestial Fire symbolized by the upper part of the Caduceus.

On the Lamén is the symbol of the cup (see Figure 47).

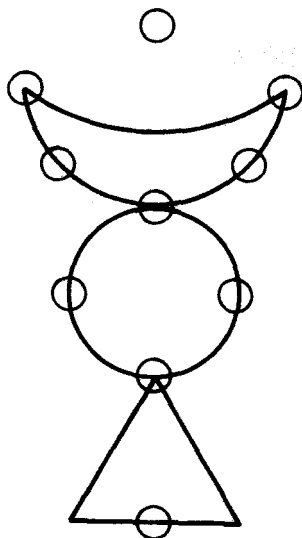

Figure 47
The Cup of Stolistes

Dadouchos

The Dadouchos, meaning, a "torch bearer," was a hereditary officer at the Mysteries of the Eleusinian Demeter, whose torch symbolized her search for her daughter Persephone, the Spirit of Youth and Spring. The verb *daio* means "to kindle," and the word *dadouchos* is compounded of *dais* (or, in Attic Greek, *das*, accusative *dada*), "a torch," especially a pine torch, and *echo*, "to hold" or "to carry." The Dadouchos, therefore, is posted in the South and symbolizes heat and dryness. S/he attends to the censer and the incense and consecrates the Hall, the members, and the Candidata with Fire. It is an important part of his/her duties to get ready and attend to all lights, fire, and incense used in the ceremonies. The Dadouchos is stationed towards the midst of the southern part of the Hall, to the southwest of the White Pillar whose base is in Netzach, and is there as an Affirmer of the Powers of Fire reflected down the Tree to Netzach. This officer is identified by the following:

- (1) The Censer he holds
- (2) Lamén

The Censer of the Dadouchos is "the Receptacle of the Powers

of Fire" and "the transmitter of the Fire of Netzach to Malkuth," restoring and purifying the vital force therein by heat and dryness. "Goddess of the Scale of the Balance of the White Pillar" is the name of Dadouchos.

The lamén of the Dadouchos (see Figure 48) is explained in the Zelator grade:

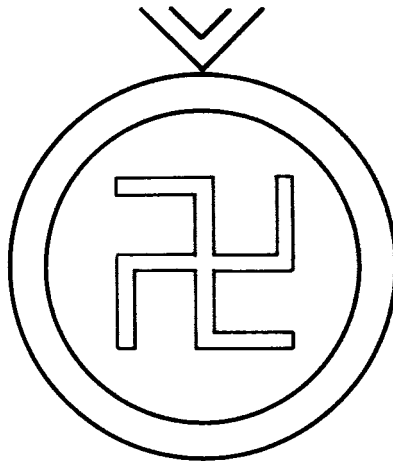

Figure 48
The Lamén of Dadouchos

The Hermetic Cross, which is also called the Fylfot, Hammer of Thor, and Swastika, is formed of 17 Squares taken out of a square of 25 lesser squares. These 17 represent the Sun, the Four Elements, and the Twelve Signs of the Zodiac.

Sentinel

The final officer is the Sentinel, or Phulax, as s/he is sometimes called. His/her name is thought to have been derived from the French, *scentinelle*, or the Italian *sentinella*. Some have even thought that it came from the French *sentier*, "a footpath," which in turn is derived from the Latin, *semita*, "a narrow way." This officer stands in charge of the Candidate at the Portal, or outer opening of the straight and narrow way that s/he is about to enter. The Greek word *phulax* signifies "a Watcher," "guard" or "sentinel"—"guardian" or "keeper." A fuller form of the word is

naophulax, meaning "keeper of the temple." The verb, *phulasso*, means, "to keep watch and ward," especially by night—and we may think of the Phulax as "the watchman" armed with, a lethal weapon to keep out intruders and to prepare the Candidate as s/he stands in the outer darkness.

The Greek word *phulacterion* means "a guarded place," "a fort," or, in its secondary meaning, "a safeguard" or "preservative," "an amulet" for protection, familiar to us from the phylacteries of the Jews, which were strips of parchment inscribed with texts from the Law and worn as amulets on the forehead while praying. The Latin word corresponding to the Greek *phulax* in a general sense is *custos*. The officer is distinguished by the following:

- (1) Sword
- (2) Lamén

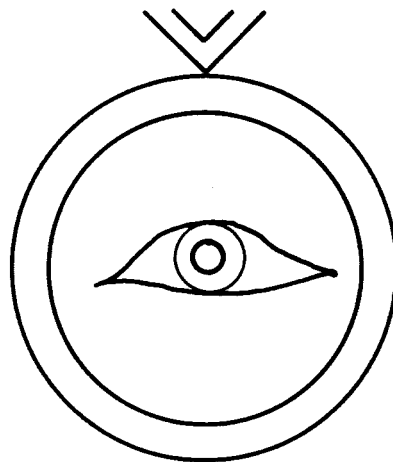

Figure 49
The Lamén of the Sentinel.

The Sword of the Sentinel has a black grip and gold guard. The black represents the darkest part of matter, while the gold guard is a reflection of the Hidden Mysteries of the Order. At all times, the sword is drawn and held upright in the left hand (for the duration of the ceremony) as a reminder of the seriousness of the occasion. Even when the Sentinel remains seated beside the door

(and outside the Portal, but still inside the Hall), the sword is still drawn.

The symbol of the Eye on the Lamén is that of the Watcher and is quite simplistic compared to some of the Golden Dawn symbolism. The lamén is shown in Figure 49.

The Pillars

From a Paper by Wynn Westcott

In the explanation of the Symbols of the Grade of Neophyte, your attention has been directed to the general mystical meaning of the Two Pillars called in the Ritual the "Pillars of Hermes" of "Seth" and of "Solomon." In the 9th chapter of the Ritual of the Dead they are referred to as the "Pillars of Shu," the "Pillars of the Gods of the Dawning Light," and also as "the North and Southern Columns of the Gate of the Hall of Truth." In the 125th Chapter, they are represented by the sacred gateway, the door to which the aspirant is brought when he has completed the negative confession. The archaic pictures on one Pillar are painted in black upon a white ground, and those on the other in white upon a black ground, in order to express the interchange and reconciliation of opposing forces and the eternal balance of light and darkness which gives force to visible nature.

The black cubical bases represent darkness and matter wherein the Spirit, the *Ruach Elohim*, began to formulate the Ineffable NAME, that Name which the ancient Rabbis have said "rushes through the universe," that Name before which the Darkness rolls back at the birth of time.

The flaming red triangular capitals which crown the summit of the Pillars represent the Triune manifestation of the Spirit of

Life, the Three Mothers of the Sepher Yetsirah, the Three Alchemical Principles of Nature, the Sulphur, the Mercury and the Salt.

Each Pillar is surmounted by its own light-bearer veiled from the material world.

At the base of both Pillars rise the Lotus flowers, symbols of re-generation and metempsychosis. The archaic illustrations are taken from vignettes of the 17th and 125th chapters of the Ritual of the Dead, the Egyptian Book of the *Pert-em-Hru* or the *Book of Coming Forth into the Day*, the oldest book in the world as yet discovered [as of Westcott's writing. The Sumerian *Epic of Gilgamesh* is now considered to be much older.—Ed.]. The Recension of the Priests of ON is to be found in the walls of the Pyramids of the Kings of the 5th and 6th Dynasties at Sakarah, the recension of the 11th and 12th Dynasties on the sarcophagi of that period, and the Theban recension of the 18th Dynasty and onward is found on the papyri, both plain and illuminated. No satisfactory translation of these books is available, none having been yet attempted by a scholar having the qualifications of mystic as well as Egyptologist.

The Ritual of the Dead, generally speaking, is a collection of hymns and prayers in the form of a series of ceremonial Rituals to enable the man to unite himself with Osiris the Redeemer. After this union he is no longer called the man, but Osiris, with whom he is now symbolically identified. "That they also may be One of us," said the Christ of the New Testament. "I am Osiris" said the purified and justified man, his soul luminous and washed from sin in the immortal and uncreated light, united to Osiris, and thereby justified, and the son of God; purified by suffering, strengthened by opposition, regenerate through self-sacrifice. Such is the subject of the great Egyptian Ritual.

The 17th Chapter of the Theban recension consists of a very ancient text with several commentaries, also extremely old, and some prayers, none of which come into the scheme of the original text. It has, together with the 12th chapter, been very carefully translated for the purpose of this lecture by the V.H. Frater M.W.T. [Marcus Worsley Blackden], and V.H. Soror S.S.D.D.

[Florence Farr] has made many valuable suggestions with regard to the interpretation. The Title and Preface of the 17th Chapter reads:

Concerning the exaltation of the Glorified Ones, of Coming and Going forth in the Divine Domain, of the Genies of the Beautiful land of Amentet. Of coming forth in the light of Day in any form desired, of hearing the Forces of Nature by being enshrined as a living Bai.

And the Rubric is:

The united with Osiris shall recite it when he has entered the Harbour. May glorious things be done thereby upon earth. May all the words of the Adept be fulfilled.

Owing to the complex use of symbols, the ritual translation of the Chapter can only be understood by perpetual reference to the ancient Egyptian commentaries, and therefore the following paraphrase has been put together to convey to modern minds as nearly as possible the ideas conceived by the old Egyptians in this glorious triumphal song of the Soul of Man made one with Osiris, the Redeemer.

I am Tum made One with all things

I have become NU. I am RA in his rising ruling by right of his Power. I am the Great God self-begotten, even NU, who pronounced His Names, and thus the Circle of the Gods was created.

I am Yesterday and know Tomorrow. I can never more be overcome. I know the secret of Osiris, whose being is perpetually revered of RA. I have finished the work which was planned at the Beginning, I am the Spirit made manifest, and armed with two vast eagle's plumes. Isis and Nephthys are their names, made One with Osiris.

I claim my inheritance. My sins have been uprooted and my passions overcome. I am Pure White. I dwell in Time. I live through Eternity, when Initiates make offering to the Everlasting Gods. I have passed along the Pathway. I know the Northern and the Southern Pillars, the two Columns at the gateway of the Hall of Truth.

Stretch unto me your hands, O ye dwellers in the centre. For I am transformed to a God in your midst. Made One with Osiris, I have filled the eye socket in the day of the morning when Good and Evil fought together.

I have lifted up the cloud-veil in the Sky of the Storm. Till I saw RA born again from out the Great Waters. His strength is my strength, and my strength is His strength. Homage to you, Lords of Truth, chiefs who Osiris rules. Granting release from Sin, followers of Ma where rest is Glorious. Whose Throne Anubis built in the day when Osiris said:

"Lo! A man wins his way to Amentet. I come before you, to drive away my faults. As ye did to the Seven Glorious Ones who follow their Lord Osiris. I am that Spirit of Earth and Sun."

Between the Two Pillars of Flame. I am RA when he fought beneath the Ashad Tree, destroying the enemies of the Ancient of Days. I am the Dweller in the Egg. I am he who turns in the Disc. I shine forth from the Horizon, as the gold from the mine. I float through the Pillars of SHU in the ether. Without a peer among the Gods. The Breath in my mouth is as a flame. I light upon the Earth with my glory. Eye cannot gaze on my darting beams, as they reach through the Heavens and lick up the Nile with tongues of flame. I am strong upon Earth with the Strength of Ra. I have come into Harbour as Osiris made perfect. Let priestly offerings be made to me as one in the train of the Ancient of Days. I brood as the Divine Spirit. I move in the firmness of my Strength. I undulate as the Waves that vibrate through Eternity. Osiris has been claimed with acclamation, and ordained to rule among the gods. Enthroned in the Domain of Horus where the Spirit and the Body are united in the presence of the Ancient of Days. Blotted out are the sins of his body in passion. He has passed the Eternal Gate, and has received the New Year Feast with Incense, at the marriage of Earth with Heaven.

TUM has built his bridal chamber. RURURET has founded his shrine. The procession is completed. HORUS has purified, SET has consecrated, SHU made one with OSIRIS has entered *his* heritage.

As TUM he has entered the Kingdom to complete union with the Invisible. Thy Bride, O Osiris, is Isis, who mourned Thee when she found Thee slain. In Isis, Thou art born again. From Nephthys is thy nourishment. They cleansed thee in thy Heavenly Birth. Youth waits upon thee, ardour is ready at thy hand. And their arms shall uphold thee for millions of years. Initiates

surround Thee and Thine enemies are cast down. The Powers of Darkness are destroyed. The Companions of Thy Joys are with Thee. Thy Victories in the Battle await their reward in the Pillar. The Forces of Nature obey Thee. Thy Power is exceeding great. The Gods curse him that curseth Thee. Thine Aspirations are fulfilled. Thou art the Mistress of Splendour. They are destroyed who barred Thy way.

The 125th Chapter is concerned with the entry of the Initiate into the Hall of the Two Columns of Justice, and commenced with a most beautiful and symbolic description of Death, as a journey from the barren wilderness of Earth, to the Glorious Land which lies beyond. The literal translation of the opening lines is as follows:

I have come from afar to look upon thy beauties. My hands salute Thy Name of Justice. I have come from afar, where the Acacia Tree grew not. Where the tree thick with leaves is not born. Where there come not beams from herb or grass. I have entered the Place of Mystery. I have communed with Set. Sleep came upon me, I was wrapped therein, bowing down before the hidden things. I was ushered into the House of Osiris. I saw the marvels that were there. The Princes of the Gates in their Glory.

The illustrations in this section represent the Hall of Truth as seen through the open leaves of its door. The Hall is presided over by a God who holds his right hand over the cage of a hawk, and his left hand over the food of eternity. On each side of the God is a cornice crowned by a row of alternate feathers and Uraei symbolizing justice and fiery power. The door leaf which completes the right hand of a stall is called "Possessor of Truth controlling the Feet," while that on the left is "Possessor of strength, binding the male and female animals." The 42 Judges of the Dead are represented as seated in a long row, and each of them has to be named, and the Sin over which he presides has been denied.

This chapter describes the introduction of the initiate into the Hall of Truth by ANUBIS, who, having questioned the aspirant, receives from him an account of his initiation, and is satisfied by

his right to enter. He states that he has been taken into the antechamber of the Temple and there stripped and blind-folded, he had to grope for the entrance of the Hall, and having found it, he was reclothed and anointed in the presence of the Initiated. He is asked for the Passwords and demands that his Soul *Thai* should be weighed in the Great Balance of the Hall of Truth, whereupon ANUBIS again interrogates him concerning the symbolism of the door of the Hall, and his answers being found correct, ANUBIS says: "Pass on, thou knowest it."

Among other things, the Initiate states that he has been purified four times, the same number of times that the Neophyte is purified and consecrated in the ceremony of the Neophyte. He then makes the long Negative Confession, stating to each Judge in turn that he is innocent of that form of Sin over which he judges. Then he invokes the Judges to do him justice, and afterwards describes how he had washed in the washing place of the South, and rested in the North, in the place called "Son of the Deliverers" and he becomes the dweller under the Olive Tree of Peace, and how he was given a tall flame of fire and a sceptre of cloud which he preserved in the salting tank in which mummies were swathed. And he found there another sceptre called "Giver of Breath" and with that he extinguished the flame and shattered the sceptre of cloud, and made a lake of it. The initiate is then brought under the symbol of the Scales of a Balance. He also has to name the Guardian of the Gateway, who prevents his passage, and when all these are propitiated, the plea of the Hall itself cries out against his steps, saying "Because I am silent, because I am pure," and it must know that his aspirations are pure enough and high enough for him to be allowed to tread upon it. He is then allowed to announce to Thoth that he is clean from all evil, and has overcome the influence of the planets, and THOTH says to him: "Who is He whose Pylons are of Flame, whose walls of Living Uraei, and the flames of whose House are streams of Water?" And the initiate replies "Osiris"

And it is immediately proclaimed: "Thy meat shall be from the Infinite, and thy drink from the Infinite. Thou art able to go forth to the sepulchral feasts on earth, for thou hast overcome."

Thus, these two chapters which are represented by their illustrations upon the Pillars, represent the advance and purification of the Soul and its union with Osiris, the Redeemer, in the Golden Dawn of the Infinite Light, in which the Soul is transfigured, knows all, and can do all, for it is made One with the Eternal God.

KHABS AM PEKHT
KONX OM PAX
LIGHT IN EXTENSION

The Z.1 document states, "Upon them [the Pillars] should be represented in counterchanged colour *any* appropriate Egyptian designs, emblematic of the Soul." [italics mine]. The bottom line was that most temples had their own Egyptian designs on the Pillars. In many ways, these were similar to the Vaults of various temples who chose their own version of the color schemes but still retained the basic design.

There has been a misconception that the Pillar drawings published by Robert Wang in *The Secret Temple* and also by Regardie in *The Complete Golden Dawn System of Magic* were the *only* ones utilized by the Golden Dawn. The object of the Pillar drawings was to show the procession of the soul in the afterlife and yet try to relate them to the journey of the Candidate in the O=O ritual. What has never been discussed in print is that only the White Pillar relates to the O=O ritual. The Black Pillar relates to the Inner Order and, as such, only the White Pillar will be discussed here. The Black Pillar will be elaborated on in a separate volume.'

The designs shown in Figures 50 through 53 are taken from the two Pillars of the New Zealand Thoth-Hermes Temple. They are

ĩThe designs for the White Pillar were commonly accepted as for the O=O. It appears that, when Mathers wrote the Portal Ritual, he had a change of heart and equated the White and Black Pillars with the Order sashes. At Whare Ra, they solved the problem by placing the drawing of Ani entering the Hall of Maat on the Black Pillar—a reversal of what some have written, such as J. W. Brodie-Trines. I have presented it the Brodie-Innes way because it fits in with early teachings. I have been informed that it did not matter to those of the first G.D. Temple, Isis-Urania, because no Egyptian figures appeared on them.

a little fuller than previous designs (including Whare Ra's, which is slightly more expansive than those designs previously published). Figures 50 and 51 show 12 panels of the White Pillar, while Figures 52 and 53 show 7 panels of the Black Pillar. A number of Golden Dawn students have asked why the original plates of the Papyrus of Ani were not left intact on those designs of the English Temple's Pillars. Both Jack Taylor and Israel Regardie were of the opinion that, when the plates of the designs from the Egyptian *Book of the Dead* were matched with the O=O, parts were left out because, in the opinion of the chiefs, they did not fully match the O=O in pertinent points. Figure 50, for example, is taken from a Thoth-Hermes lecture.

Panel 1. This plate shows both men and women as candidates (analogous to Ani and his wife) waiting in the antechamber of the temple before entering. They are shown playing chess, for this meaning is a subtle, hidden one. Chess is a game of strategy and thinking, hence the couple have carefully thought out the moves of deciding to enter the Order. The hawk and feather outside the anteroom represents Ament (Amentet), a Goddess of the West, the place of the setting sun and entranceway to the Hall of the Neophytes, which is synonymous with the Dwelling Place of the Dead. Ament was considered the welcomer of the dead. This whole concept, related back to the Order, shows the candidate leaving behind the old values. The bread and beer also show that nourishment will be provided on the journey of the candidate.

Panel 2. The human-headed hawks seated on the roof of the tomb relate to the two Higher Selves of the Candidates, who take their appropriate place in the Hall of the Neophytes. The figure praying beside them represents Ani (from this point on, we follow a single individual on the journey) and shows that the correct rites of initiation are being applied. The two lions back to back are Set and Tau, who support the horizon. These relate back to the two Pillars of the Temple, the entranceway to the Abode of the Blessed, which relates to the Order concept of the Unification of Osiris—our Higher Self.

The Pillars

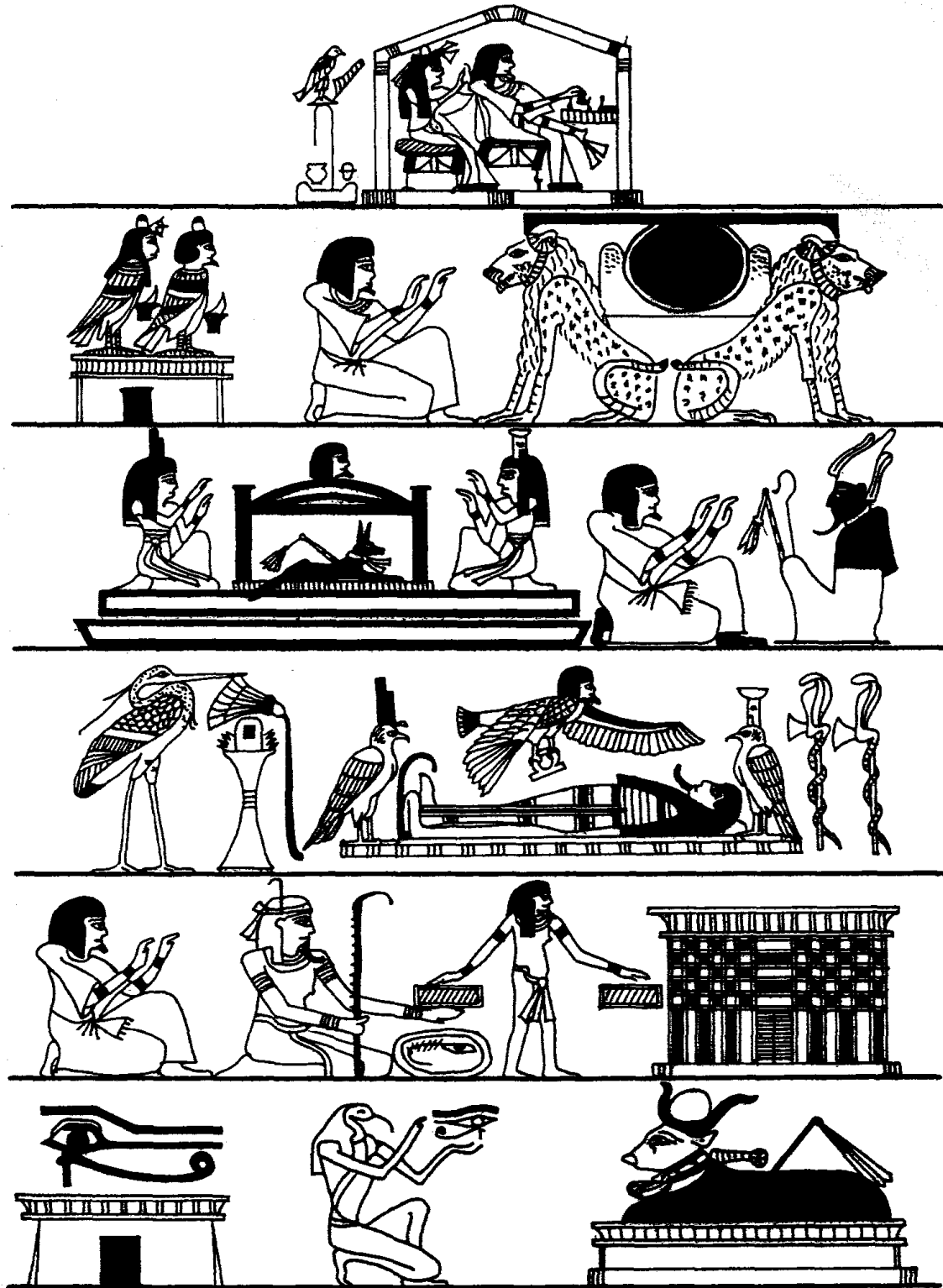

Figure 50
Upper Panels of the White Pillar

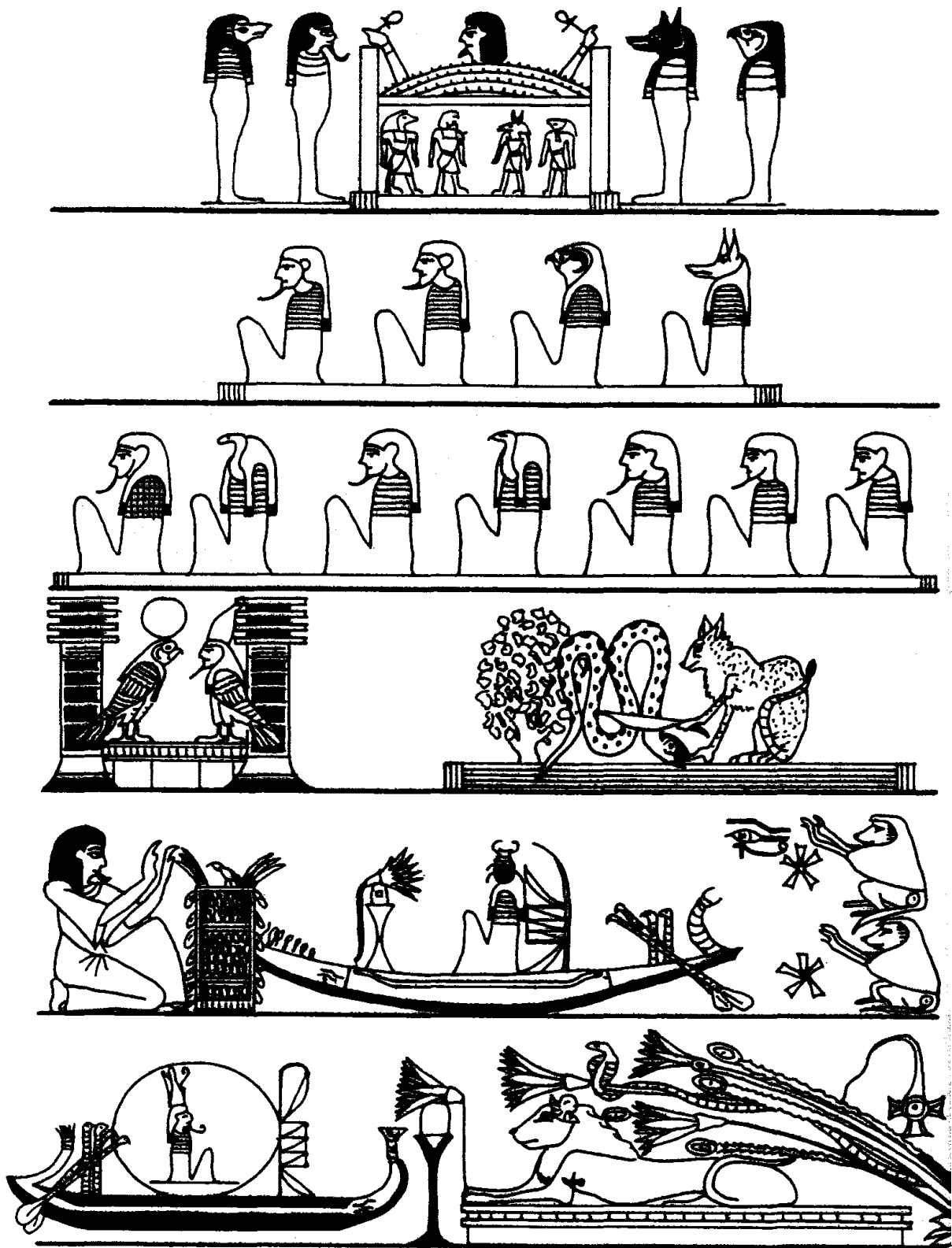

Figure 51
Lower Panels of the White Pillar

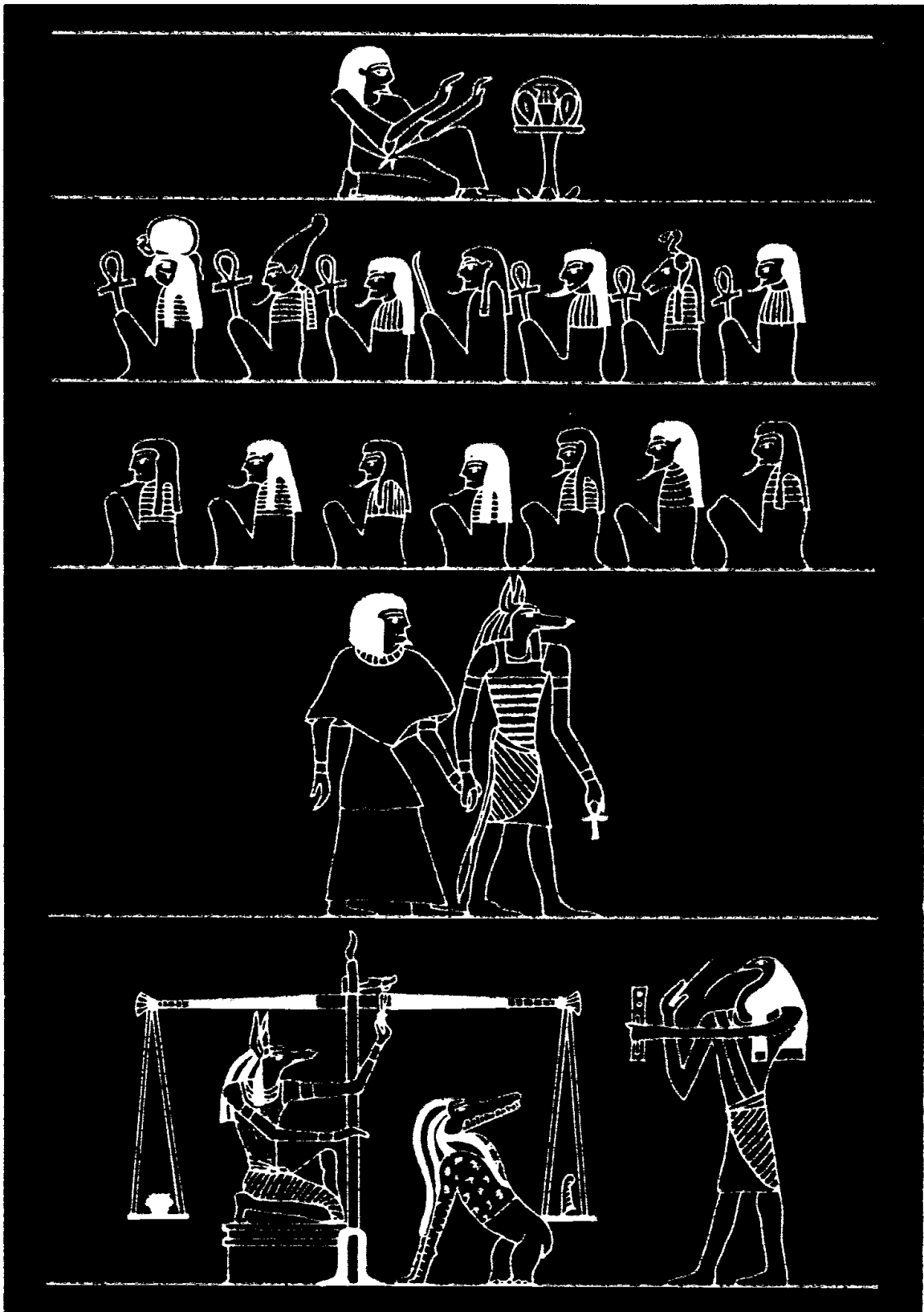

Figure 52
Upper Panels of the Black Pillar

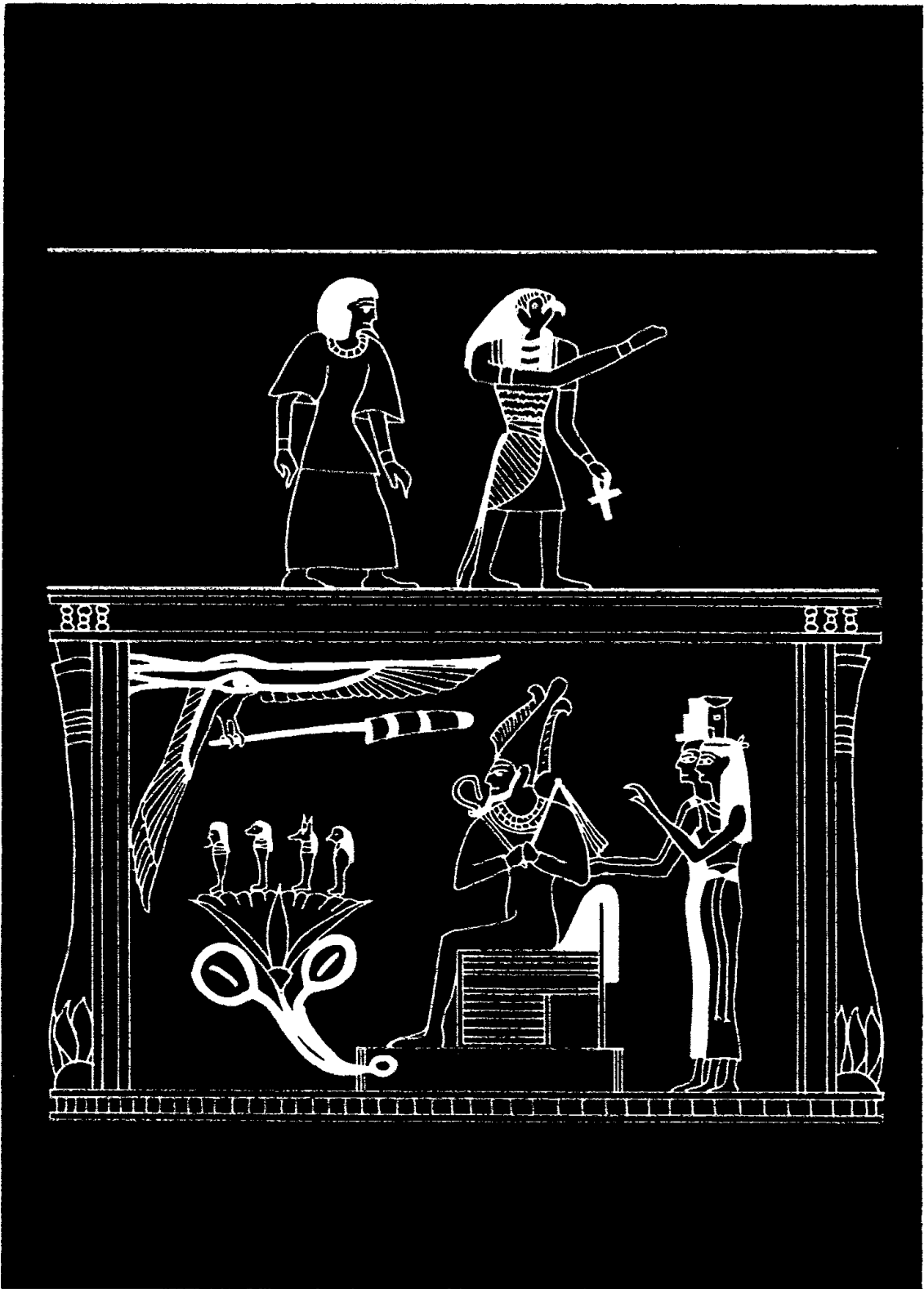

Figure 54
Lower Panel of the Black Pillar

Panel 3. Here we have the body of Ani with Nephtys at the left and Isis at the right hand side of the funeral bier, guarded by Anubis. This was called the Abode of the West. It is the point in the circumambulation where the Hieres bars the way of the Candidate and informs him of the thin line he walks between Light and Darkness. On the far right of this plate, Ani (as the Candidate) is before Osiris (as the Hierophant), and it is his reception in the East, the first major part of the transformation, his revelation.

Panel 4. In this plate, the body of Osiris has been transformed into the Benu Bird through the purification process. The Candidate's acceptance into the Order is shown through "Khabs Am Pekht, Kong Om Pax—Light in Extension." The lotus, libation vase, and offerings on the altar represent further symbols of the transformation process as represented in Order symbology by the cross above the triangle by which the Candidate must swear in order to fully transform himself. The next aspect of this plate shows Ani lying on the bier with the forms of Nephtys and Isis (in hawk form) at each end while his Soul hovers above him with two ankhs of power. The two Urae Goddesses are also present (representing North and South). This refers to the Speech of the Hierophant and the placement of the Neophyte between the Pillars, where he is instructed in the secret signs etc. and is readied for his final consecration. The soul above him is the Higher Self advancing upwards.

Panel 5. In this place, we have Ani approaching the Water God or the final consecration of the Neophyte. The staff held by the Water God is the symbol of the year, which is the password of the Equinox. The whole process is a continuation of the soul or Higher Self of the Neophyte, which has soared upwards, passed the watchful Eye of Horus to its reception in Pools of the Two Truths, which are held together by Uatch-ura. The right-hand lake is the "Pool of Natron," while the left-hand lake is the "Pool of Salt" (another concept of the two Pillars). This shows the actions of the Higher Self in the ritual, though the Neophyte, in the

physical, has not moved from the previous diagram and the actions are all on a Higher Plane. The final drawing on this plate is the Rasta, the South Gate of Anrutef, part of Herakleopolis and Northern Entrance to the Land of the Dead through which the Neophyte passes through in the circumambulation.

Panel 6. The Eye of Ra, as Osiris, over the funerary building shows the effect sunrise brought about in the 0=0 ritual by the Mystical Circumambulation in the Pathway of Light. Here the sun (which is also the soul of the Neophyte) has appeared and petitions the Guardian to give it access and strength because it is of the same substance as the gods themselves--immortal. The next figure is Thoth raising the Eye of Osiris, showing that the soul or Higher Self of the Neophyte is without blemish (this is omitted in the Brodie-Innes description of the White Pillars). The inference is that the Higher Self of the Neophyte has returned to its proper place, like the story of Thoth who overtook Set and restored the Eye to its correct place in the sky—shown as the Sky Goddess, Mehurt, Daughter of Ra and symbolic of the Heaven.

Panel 7. This shows a funeral chest with the Head of Ra, who is holding twin ankhs emerging from the pastos. It relates to Osiris as Ra partaking of himself—death and resurrection, with the four children of Horus standing by. This is the proclamation of the motto by which the Neophyte will now be known among the Order members, which relates to a rebirth.

Panel 8. The Four Canopic Gods relate to the four officers on the Dais (excluding the Hierophant), the Chiefs behind Osiris, who control the 0=0 from their thrones. Their actions have been explained previously (which was never before given to the grades of the 5=6 or below).

Panel 9. The seven gods (which are formed from the ones above) relate to the officers of the temple floor (excluding the Sentinel).

Panel 10. This plate has Two Pillars with two hawk forms between them. The hawk with the Solar Disk is Ra, while the other is Osiris. The Pillars themselves represent Tet or human sacrifice (from the cult of Tetu). Within the O=O, this is shown when the blood is shown to the Neophyte to remind him of his oath. The next symbol, of a cat severing a snake near an acacia tree, relates to the victory of the forces of Osiris over Typhon-Set (the snake) as the last vestiges of impurity have been removed. This relates to the reverse circumambulation in the O=O ritual.

Panel 11. This plate shows Orisis-Ani in adoration before the god Kephera, going by in his Solar Boat. This relates to the Final Adoration in the Ritual. Kephera is a symbol of the Creator to whom the Adoration was made.

Panel 12. This shows Tern in his boat and the god Rehu in lion form. Though this plate is hard to explain at the best of times, the Order considers it the reunification with Osiris and the following of his doctrine shown by the Partaking of the Eucharist Ceremony at the end of the O=O ritual, where his essence is received and united with.

The Enochian Tablets and the Neophyte Ritual

The Enochian system and its association to the O=O ritual has been for many years something of an enigma since, in the drawing of the temple diagram, no such tablets are shown or mentioned. However, within the Inner Order, a number of papers have survived that tie the Elemental associations which compose the Enochian pyramid squares to the god-forms that rule them, and their associations to the temple officers (with the exception of the Cancellarius, Hegemon, Stolistes, and Dadouchos). What a number of students do not realize is that, while there are no Enochian Tablets indicated in the O=O ritual, in the permanent temples such as Isis-Urania, Bristol-Hermes, Whare-Ra, and so on, the four Tablets were left on the temple walls and were covered by a curtain the color of the element that they represented. When the Elemental grade ceremonies were done, the curtain of

the particular tablet required was drawn back for the duration of the ceremony.

The curtains stifled the corporeal energies of the tablets. Their incorporeal form positively affected the ceremony, and it is this etheric energy that the temple officers drew upon. Whether Mathers originally intended this to happen is anyone's guess. Most of the early rituals were done in drawing rooms, and so on, and, more than likely, if he had so intended, the tablets would have been indicated. However, in the permanent temples, people like Jack Taylor (who held the office of Hierophant on and off for over 35 years at Whare Ra) noticed that the curtains barely stopped the etheric energies of the tablets from emanating during the 0=0 ceremony. They emanated even more so during the elemental ceremonies, when the incorporeal and corporeal energies had to be correctly balanced for the ritual to be a success. It is not our intention to involve ourselves deeply with Enochian semantics in the 0=0. However, since this book is for both Adept and Neophyte, it is impossible to separate one from the other. We would ask our readers who are not familiar with the Golden Dawn's version of the Enochian system to refer to the works of Aleister Crowley and Regardie, who have covered this subject more than adequately. The following breakdown gives the Enochian Square association to the 0=0 officers:

Enochian Squares and 0=0 Officers

Elements of Pyramid Square	God-Form	0=0 Officers
SPIRIT, or one triangle of each element	Osiris	Hierophant
WATER, or 3 out of 4 Water	Isis	Praemonstrator
EARTH, or 3 out of 4 Earth	Nepthys	Imperator
FIRE, or 3 out of 4 Fire	Horus	Hiereus
AIR, or 3 out of 4 Air	Aroueris	Past-Hierophant
2 Water, 2 Earth	Athor	Invisible Station Kerub of the East
2 Fire, 2 Water	Sothis	Invisible Station Kerub of the West
2 Air, 2 Water	Harpocrates	Invisible Station between Altar and Hegemon
2 Fire, 2 Earth	Apis	Invisible Station Kerub of the North
2 Air, 2 Earth	Anubis	Kerux
2 Fire, 2 Air	Pasht	Invisible Station Kerub of the South
Fire/Water/Earth	Ameshet	Invisible Station N.E. Child of Horus
Fire/Water/Air	Ahephi	Invisible Station S.W. Child of Horus
Earth/Water/Air	Tmoumathph	Invisible Station S.E. Child of Horus
Earth/Air/Fire	Kabexnuv	Invisible Station N.W. Child of Horus

Symbolism of the Opening

General

Within the Z.1 document, the General Exordium says:

1. The Speech in the Silence:
2. The Words against the Son of Night:
3. The Voice of Thoth before the Universe in the presence of the eternal Gods:
4. The Formulas of Knowledge:
5. The Wisdom of Breath:
6. The Radix of Vibration:
7. The Shaking of the Invisible:
8. The Rolling Asunder of the Darkness:
9. The Becoming Visible of Matter:
10. The Piercing of the Coils of the Stooping Dragon:
11. The Breaking forth of the Light: All these are in the Knowledge of Tho-oth.

For some, the above verse may appear incomprehensible, but it is a code for breaking down the Opening of the 0=0 Ceremony. The general meaning of the above verse relates to the Great Thoth, the highest aspect of the Hermes of the most ancient Egyptian Mysteries, and corresponds almost to the Great Angel Metatron. It is the Archangel of Kether in the Briatic World. The Mercury of the Romans must not be confused with this Great Hermes. The doctrines of Gnosticism and of Valentinus approached those of the pure Kabbalah. In them, we find Speech

and Silence. Across the Abyss of Silence comes the Primal Speech. The Divine Ones here referred to are the Aeons of the Atziluthic World. These formulae of knowledge are designed in terms cognizable to us in the lower world. Taking as an example, we have Eheieh, an implicit and explicit sound. "Every being pronounces its existence, the Name of the Lord of Life, by inspiration and expiration."

The Macroprosopus is Aima and Abba, Mother-Father. The two nostrils pass up and down the two breaths, as through two Great Pillars. These throw all things into vibration; compare the Rashith ha-Gilgalim "Piercing of the Dragon's Coils" suggests the freeing of Malkuth, which is also referred to as the Washing of the Garments of the Queen, the inferior Mother. Then comes the Breaking Forth of the Light. Over Malkuth, as Guardians, are Metatron and Sandalphon, as the Two Pillars, and Nephesh ha- Messiah, the animal soul of Messiah, the Shekinah or Presence between the Kerubim.

Commentary on the General Exordium

1. The Speech in the Silence

This relates to the knock that the Hierophant gives to start the ceremony and to announce the commencement of a vibration in the Sphere of Sensation (aura) of the Candidate. This knock can be done with a stamp of the foot. Some hierophants use the base of the scepter against the throne.

2. The Words Against the Son of Night

Here we have the Cry of the Kerux, the Watcher Within, with the words "HEKAS, HEKAS, ESTE BEBELOI" (which roughly means that anyone who should not be present should get out!). The Kerux utters these words when he/she goes to the right of the Hierophant and raises his/her Wand. This is a symbol of the Ray of the Divine Light from the White Triangle of the Three Supernals, which then descends into the Darkness and warns the Evil and uninitiated to retire so that the White Triangle may be formulated upon the Altar through the combined effect of the formula of the Opening Ceremony.

3. *The Voice of Thoth before the Universe in the presence of the eternal Gods*

This is analogous to the opening speech of the Hierophant, where he/she asks the Kerux to check that the Hall is properly guarded, for this assures that the Portal is secure and that the energy from the current of Thoth had now manifested into the ceremony.

4. *The Formulas of Knowledge*

In this instance, the Hierophant calls to the Hiereus to test the members present by the "Signs of Knowledge," which shows that they, though in the Land of Blindness and Ignorance, have yet seen that the Triangle of Divine Light from the three Supernals is formulated in Darkness. You will note that the Hierophant gives the Sign of the Enterer towards the West, and it is not immediately followed by the Sign of Silence. For here the Hierophant has sent the current of Light through to the Hiereus, but he/she cannot release it (through the Sign of Silence) until it links directly into the Hiereus's throne—for then the central axis is established through Samekh and Tau. Once he/she gives the words to reawaken the images or shells of the god-forms, he/she then releases his/her current with the Sign of Silence; otherwise he/she would expend it and exhaust himself

5. *The Wisdom of Breath*

It is noted that the names of the three chief officers begin with the letter "H," the letter of breath. This letter relates to its Coptic meaning, which to a certain extent is the letter H in English and can only convey its meaning in part. Taking two examples, we have 2 concealed in the name Osiris by the H, the Greek capital letter *eta*. In the name Horus, it is manifest and violently aspirated, while in the name Thmaest, it is partly one and partly the other for it is compounded with the letter "T" in the Greek letter *theta*, 0 (H, "Ae," is attributed to Chesed— 2 and 0 to Earth and Saturn. This is intended to affirm the Unknown Life, which is inspired from the Beyond, sent out to Aries, the commencement of the spring of the year, the life which, after being inspired, is breathed forth again. It is also the possible use

of that breath, between the inspiration and the expiration, in combination between it and the forces of the microcosm.)

6. *The Radix of Vibration*

The whole is a rehearsal of the properties of the reflection of the element Air down through the Middle Pillar of the Sephiroth. It represents the reflection of Air from Kether, through Tiphareth to Yesod, and even to the citrine part of Malkuth. For the subtle Aether is, in Kether, inspired from the Divine Light beyond; thence reflected into Tiphareth, wherein it is combined with the reflexes from the alchemical principles in that great receptacle of the forces of the Tree. In Yesod, it affirms the foundation of a formula, and from Malkuth it is breathed forth or reflected back. This formula can be used by the Adept. Standing in his Sphere of Sensation, he can, by his knowledge of the sacred rites, raise himself unto the contemplation of his Yechidah and from thence aspire (in the sense of the Adspire; i.e., to attract *towards* you in breathing) downwards into himself the Lower Genius as though temporarily to inhabit himself as its temple (see Regardie's *The Middle Pillar* for a fuller explanation of this).

Another formula of vibration is hidden here. Let the Adept, standing upright, arms stretched out in the form of a Calvary Cross, vibrate a Divine Name, bringing with the formulation thereof a deep inspiration into the lungs. Let the breath be retained, mentally pronouncing the Name in the heart, so as to combine it with the forces desired to be awakened thereby; thence sending it downwards through the body past Yesod, but not resting there, but taking his or her physical life for a material basis, send it on into the feet. There momentarily formulate the Name—then, bringing it rushing upward into the lungs, thence breathe it forth strongly while vibrating that Divine Name. He or she will send the breath steadily forward into the Universe so as to awaken the corresponding forces of the Name in the Outer World. Standing with arms out in the form of a cross, when the breath had been imaginatively sent to the feet and back, bring the arms forward in "the Sign of the Enterer" while vibrating the Name out into the Universe. On completing this, make the "Sign

of Silence" and remain still, contemplating the force you have invoked.

This is the secret tradition mode of pronouncing the Divine Names by vibration, but let the Adept beware that he or she applies it only to the Divine Names of the Gods. If this thing be done ignorantly in working with the Elemental or Demonic Names, the Adept may bring into himself or herself terrible forces of Evil and Obsession. The method described is called "The Vibratory Formula of the Middle Pillar."

7. The Shaking of the Invisible

This refers to the "Awakening of the Images—the Invisible Stations." Here the temple officers must link their Spheres of Sensations with the Invisible Images of the god-forms through the vibratory formula.

8. The Rolling Asunder of the Darkness

This particular phrase of the General Exordium relates to the symbolism of the Mystical Circumambulation in the Outer temple—the Macrocosm. Here we have the Procession of Officers forming in the North in readiness for the "Mystic Circumambulation in the Path of Light." This is formed in the North, beginning from the Station of Stolistes, the symbol of the Waters of Creation attracting the Divine Spirit, and therefore alluding to the Creation of the World by the Spirit and the Waters. The Order of the Mystic Circumambulation is as follows: First comes Anubis, the Watcher within. Next comes Thmaest, the Goddess of the Hall of Truth. Then comes Horus. Then comes the Goddess of the Scales of Balance. Then come the members, if the Hall be large enough, and, at the end, the Watcher Without, the Sentinel. It is as though a gigantic Wheel were revolving and expanding, as it is said: "One Wheel upon Earth beside the Kerub." The name of the Sphere of the Primum Mobile, Rashith ha-Gilgalim, signifies the heads or beginnings of whirling motions or revolutions. Of this wheel in the Mystic Circumambulation, the ascending side begins from below the Pillar of Nephthys, and the descending side from below the Pillar of Isis.

9. The Becoming Visible of Matter

The above phrase still refers to the Mystic Circumambulation, but especially to the effect of the Rise of Light in the individual. These, of course, occur simultaneously with 8, but are placed here to affirm that the subtle body centers awaken within the officers and the Candidate. Here, the auras of the officers flood with the light and power of the ceremony, which to many are quite visible. The axis of this wheel is about the Invisible Station of Harpocrates—as though that god, in the Sign of Silence, were there placed affirming the Concealment of the central Atom of the Wheel, which alone revolves not.

10. The Piercing of the Coils of the Stooping Dragon

This is best explained by referring to the Golden Dawn Lecture, "The Law of the Convolution of the Forces Symbolized by the Four Aces Round the Northern Pole," which in turn can be related to the "Stooping Dragon Formula." This is extremely complex and was originally reserved for the Theoricus Adeptus Minor Grade, but the formula referred to above applies to the Microcosm. The Mystic Circumambulation is symbolic of the Rise of Light, and from it is drawn another formula for the circulation of the breath. It is the Formula of the Four Revolutions of the Breath (this of course does not mean the actual air inspired can be thus circulated, but only the subtle Aether which may be drawn thence, and of which it is the vehicle). This formula should be preceded by that of the Middle Pillar. By this method, having invoked the Power you wish to awaken in yourself, and contemplated it, begin its circumambulation thus: Fill the lungs and imagine the Name vibrating in the contained air. Imagine this vibration going down the left leg to the sole of the left foot—thence passing over to the soul of the right foot—up the right leg to the lungs again where it is breathed out. Do this four times to the rhythm of the Fourfold Breath.

11. The Breaking forth of the Light

The object of the Mystic Circumambulation is to attract and make the connection between the Divine Light above and the temple. Therefore, the Hierophant does not quit his/her post to

take part therein, but remains there to attract, by his/her scepter, the Light from beyond the Veil. Each member, in passing, gives the Sign of the Enterer, thus projecting the Light forward on his Path from East to West, as he is the Son of Osiris and inherits the Light by birthright from him. Therefore, he goes at once to his station to fix the Light there. Thmaest, the Goddess of Truth, passes twice because her rule is of the Balance of the Two Scales, and she retires to her station between the Pillars there to complete the reflex of the Middle Column. The Watcher Within and the rest circumambulate thrice, as affirming the completion of the reflection of perfecting of the White Triangle of the Three Supernals upon the Altar. Then follows the Adoration of the God, the Vast One, the Lord of the Universe—at which again all give the Sign of the Enterer, the Sign of the Projection of the Force of Light. Only then does the Watcher declare that the sun has arisen and that the Light shineth in darkness. Now comes the battery of the 0=0 Grade—the single knock by the Hierophant which is repeated by the Hieres and Hegemon. This affirms the establishment of the White Triangle and therefore the Completion of the Opening Ceremony. The mystic words "Khabs Am Pekht" which accompany the knocks seal the image of the Light. Their significance implies, by various Kabbalistic methods of analysis, as well as by certain reading of the Coptic and Egyptian hieroglyphics, "Light in Extension" or "May Light be extended in Abundance upon you." Konx Om Pax is the Greek corrupted pronunciation of this, put here to link the right origin.

Symbolism of the Opening—Particular

From the first knock, a current is activated in the Hierophant. This is drawn to the Hieres, through Hegemon, then from the Dadouchos, to the Stolistes in the form of a cross with the altar as the center. This is a combination of the energy of all four crosses worn by those officers on the Dais. The Kerux, you will note, is not the recipient of any of the arms of the cross due to the fact that his/her position is not a fixed but a fluid one.

The Consecration

The consecration is an extremely precise movement pattern where, once the officers have linked the Light between them, they move in unison, like the minute hand of a clock. Each stops and starts together. You will also note that, at each position in which they consecrate it, it is done in a triad which represents the Kabbalistic Supernals of the unmanifested. The use of the first two fingers by the Stolistes when consecrating was something passed on to us from Whare Ra. It was considered quite important. The two fingers were said (by one Whare Ra Adept of 8=3 rank) to represent the Horns of the Evil One, which present a mirror image to any negativity lurking about. It is thought to nullify and confound anything of evil intent. The Dadouchos also uses these same two fingers to work the chain on the censer. Much of this, though, was a variation of the old church theme of banishment or excommunication. However, if one projects with the fingers through the Ruach it has a more effective outcome while the appropriate Name is silently vibrated in each quarter; it can clear the air very quickly. This effectiveness is based on the power of the god-form one has assumed for the duration of the ceremony.

One of the things we were taught was that, whenever possible, two people who are harmonious should take the parts of Stolistes and Dadouchos. When antagonism exists, it will ultimately come out, and usually it will play havoc with the ceremony. These two officers are controlled by the Hegemon as the tip of the triad. It is his/her duty (generally speaking, the part of Hegemon was played by a woman to help identify more quickly with the Maat principle) to link his/her aura with that of the Pillars, then from them to the Stolistes and Dadouchos while they link themselves. S/he must draw from one and give to the other (in terms of empathic energy) through the power of the Pillars. Some years ago, a friend of ours who held the office of Hegemon at Whare Ra Temple on and off over a 20-year period gave us an example of a married couple who held the offices of Stolistes and Dadouchos and who attended a ceremony just after a bitter argument. She, as Hegemon, had to try and balance their energies, which proved

to be quite a formidable task for the duration of the ceremony. It has also been our experience that it is very important to check the elemental positions from a person's natal chart to see if they are suited for positions such as Stolistes and Dadouchos. The pivot of Stolistes and Dadouchos is like the half-hour position of a clock—the two officers must be directly opposite each other during the movement. The one who finishes the consecration first waits for the other to finish before moving. The published papers of Regardie show a quarter-hour position. This was changed by those at Bristol Temple.

The Circumambulation

When the Golden Dawn rituals were first penned by Mathers, the circumambulation of the Rise of Light was always circular and around the outside of the Pillars. However, as the ritual expertise developed within the Stella Matutina, a number of Adepti became aware of rings or spirals of energy emanating from the Altar. While it is true that the initiating power comes from the Hierophant's throne in the East, the Altar also generates power as well. This is one of the reasons why it is situated where it is and not in the East. By analogy, the Hierophant's throne is like a switch to turn the current on, while the Altar is analogous to the light bulb situated in the center of the room to spread light to all areas equally.

Though Adepti in the Stella Matutina (including Dion Fortune, according to Regardie) were aware of these energy rings during ritual, very little was explained in the Z documents as to why they existed when the Portal was opened in the 0=0. In New Zealand, we started experiments by tracing these patterns of energy. We found that they were not "rings" as originally thought, but spirals of exactly three and a half turns, the same number of turns as in the circumambulation. The outward reach of the spirals went as far as the Pillars, then ceased. It occurred to us to do the circumambulation *within* the Pillars instead of without, and this brought an immediate change in tempo for the whole ceremony.

The members would start off very close to the Altar, then

gradually work their way outward with each turn. Some members became very adept at detecting the spiral by tracing the energy patterns with their knee; it felt like a warm current of air or heat sensation. This was the largest modern change in the rituals by Thoth-Hermes members, though we do suggest to those readers who are active in Golden Dawn ritual to try this method for themselves and see what the results bring. The spiral, of course, in no way interferes with the basic essence of its origins but rather compliments and even transcends it.

One of the main ritual problems that Adepts of the Stella Matutina, and later the Smaragdum Thalasses, complained about was the "dead air" during the old circumambulation, as sometimes they would connect and sometimes they would not. It was found that, in the original circumambulation, the officers picked up and tried to use the last circle of the spiral. The Pillar positions became of prime importance because, at temples like Whare Ra, a little closer to the Altar than normal allowed for the final spiral from the Altar to encompass them. In cases when the Pillars were placed in the outer ring, this distorted the spirals from the Altar. Two things now became apparent. The first was that the altar size generated different size spirals. The second was that the Pillars stopped or interfered with the spirals, which were completely spent after three and a half circumambulations. If the Pillars were placed too close to the Altar, then the spirals or even the old form of the circumambulation became lopsided and emanated very erratic forms of energy. Another point of note is that the spirals took one directly over the station of the Evil One, which gave the circumambulation more control and power (which will be discussed later). The circumambulation used is shown in Figure 54.

The Particular Exordium

In the Z.1 Document, the Particular Exordium states:

1. At the Ending of the Night: At the Limits of the Light: Tho-oth stood before the Unborn Ones of Time!
2. Then was formulated the Universe:
3. Then came forth the Gods thereof:

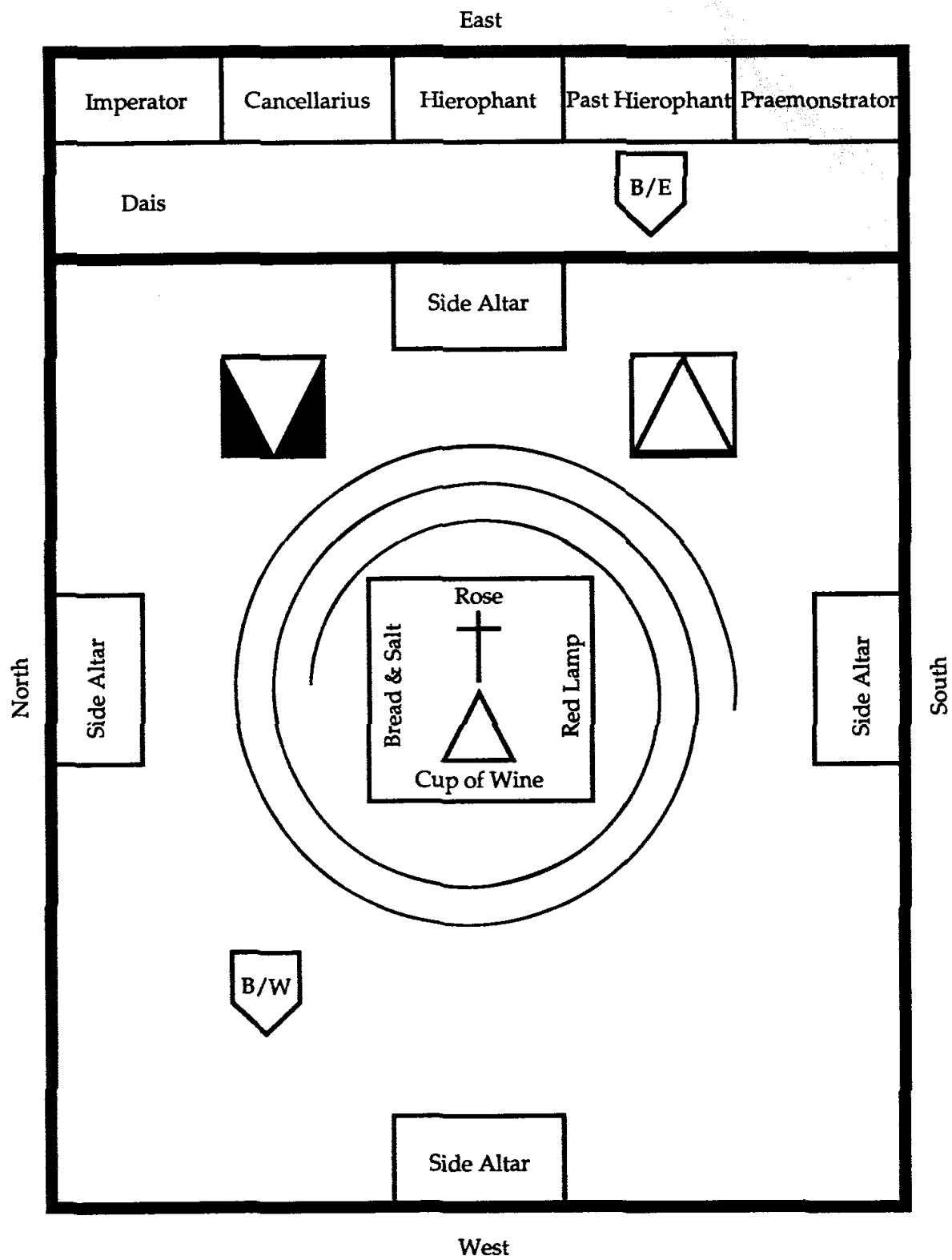

Figure 54
The Circumambulation

4. The Aeons of the Bornless Beyond:
5. Then was the Voice vibrated:
6. Then was the Name declared.
7. At the Threshold of the Entrance,
8. Between the Universe and the Infinite,
9. In the Sign of the Enterer, stood Tho-oth,
10. As before him were the Aeons proclaimed.
11. In Breath did he vibrate them:
12. In symbols did he record them:
13. For betwixt the Light and the Darkness did he stand.

The Bornless Ones of Time referred to are those coruscations of the Divine Light which are above Kether of Atziluth. In such Supernal realms, the Ain Soph, though negative to us, is there intensely positive. Thence came forth the Gods, the Voice, the Aeons, and the Name. The Egyptian Gods were generally differentiated by their Crown (for example, Amen-Ra by the feathers). Mo-oth (Maut) has the same headdress as Horus. She corresponds to the Aima Elohim. The high Hermes-Tho-oth has the same headdress as Amoun Kneph, the Sacred Spirit. Tho-oth, Truth, has two aspects—the higher and the lower. The higher is absolute; the lower is suitable to human comprehension. To tell the higher form of truth to one who cannot understand it, is to lie to him/her because, though correctly formulated, it will not be correctly received.

Applied directly to the 0=0, the Particular Exordium is the form of the ADORATION.

"Holy art Thou, Lord of the Universe!" (lines 1-2) Holy are Thou, Whom Nature hast not Formed! (lines 3-6) Holy art Thou, the Vast and the Mighty One ! (lines 7- 12) Lord of the Light and of the Darkness." (line 13)

The Adoration is done immediately after the circumambulation. There are three Signs of the Enterer and a Sign of Silence and these are directed towards the throne of the Hierophant. The object of this was for the Hierophant to push the Veil of Paroketh asunder with the self-contained energy in the temple, now firmly linking itself to the energy of the Second

Order through the Hierophant. The temple actually takes three phases to open correctly. The first is the knock and exchanges by the officers. The second is the circumambulation, and the third is the Adoration. At this point, the Altar is the focal point of energy, but the Adoration links the portal firmly with the powers beyond the Veil. In this instance, there are three Signs of the Enterer before the final Sign of Silence. With the Sign of the Enterer, the energy is directed at the Throne of the Hierophant, who, as Osiris, absorbs this energy coming to him/her from a balance of all officers. In this instance, he/she is just like an electrical conductor. The energy links to the officers on the floor through the Hierophant to the points beyond the Veil. The reason for the three Signs of the Enterer is that they emulate the power of the Supernals shown by the triangle on the Altar. The final Sign. of Silence acts as a form of protection against any backlash of the current pushed by the Hierophant. This prevents a residue from coming back which could destroy the created portal.

With the words, "Khabs Am Pekht, Konx Om Pax—Light in Extension" the Hierophant then seals the link to the portal which the Adoration broke through to receive. As each officer knocks, the energy comes back through the Hierophant and links to them. The Kerux, Dadouchos, and Stolistes, as lesser officers, are not included. The Hegemon, for example, handles the energy of Stolistes, Dadouchos, and Kerux, as the Hegemon must regulate the energy to the other three.

To finalize this part of the ceremony, the Kerux removes the Lamp, Rose, Cup, and Paten of bread and salt from the Altar (see Figures 55 through 59). Starting at the East and moving in a clockwise direction, these items work together on many different levels. In their more basic form, they represent the organs of the body of the deceased and are placed in the four directions with the organs of the alimentary system (the most material and earthy) in the North, those of the circulatory system in the South, the receptive system in the East (the Source of Life and Light), and the organs that cast out in the West (which borders on the Qlipoth). The relationship to these bodily organs may appear at first glance to be symbolic, but they are actually worked on

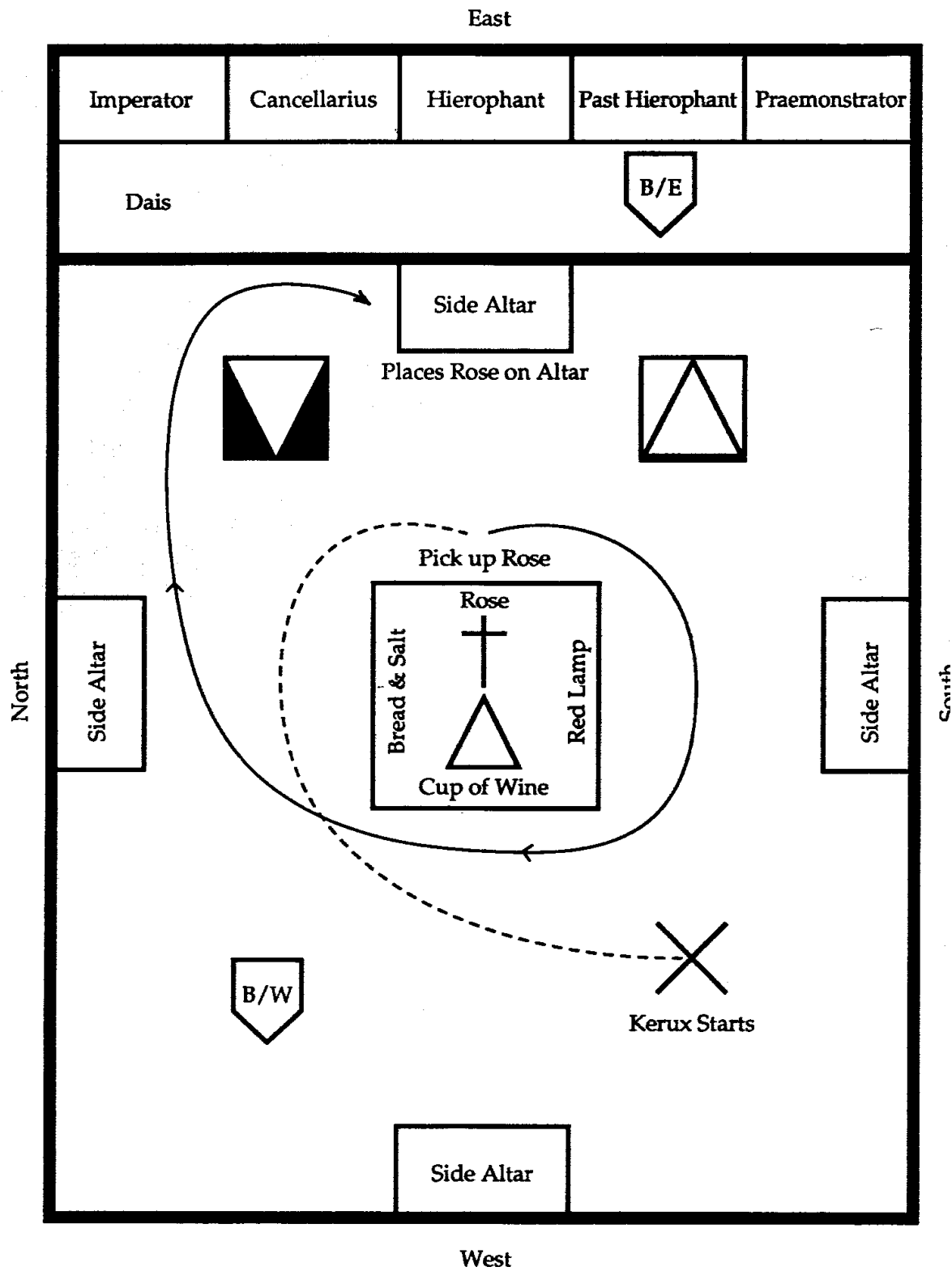

Figure 55
 Circumambulation of the Kerux — Beginning

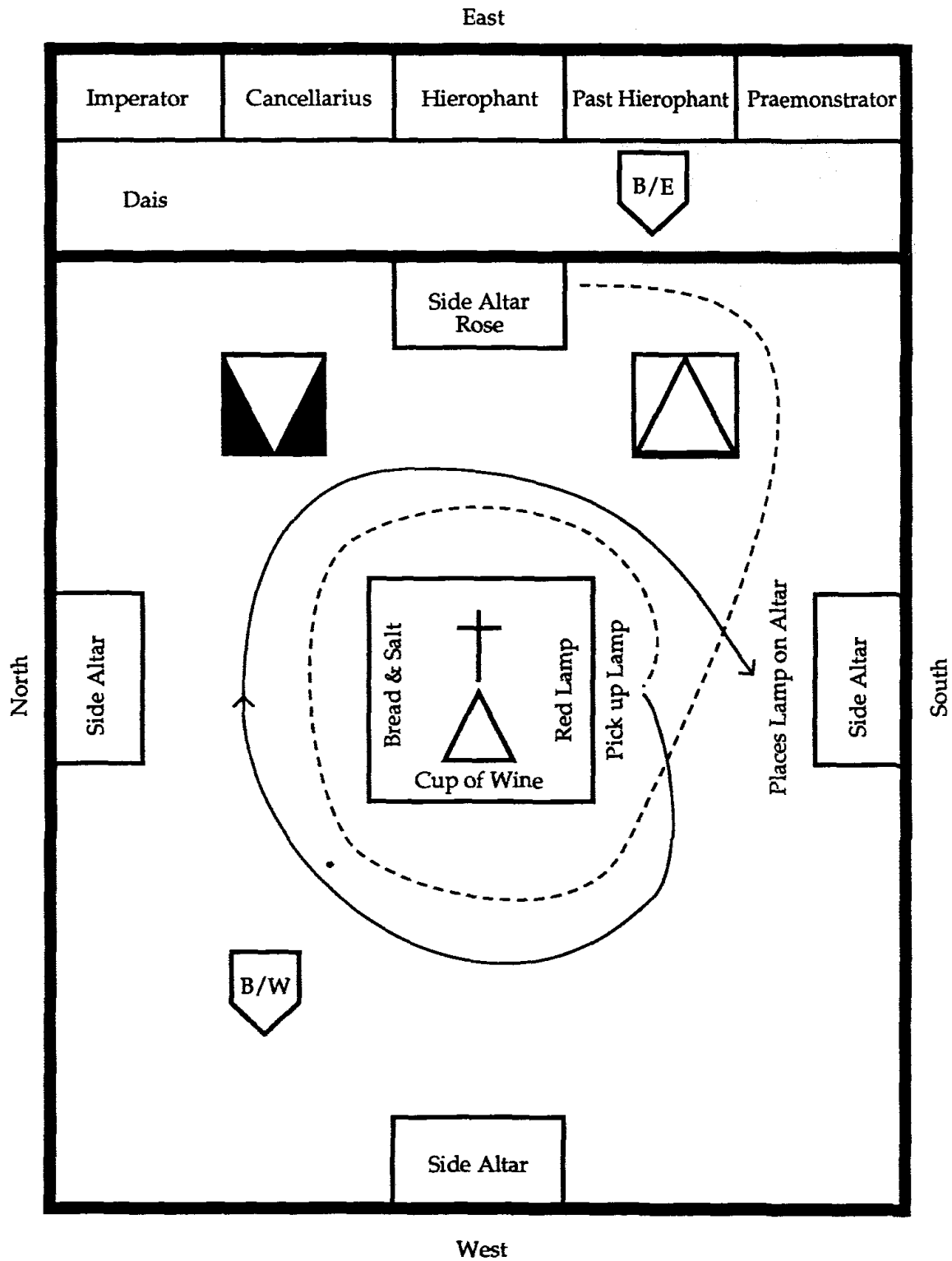

Figure 56
Circumambulation of Kerux from East to South

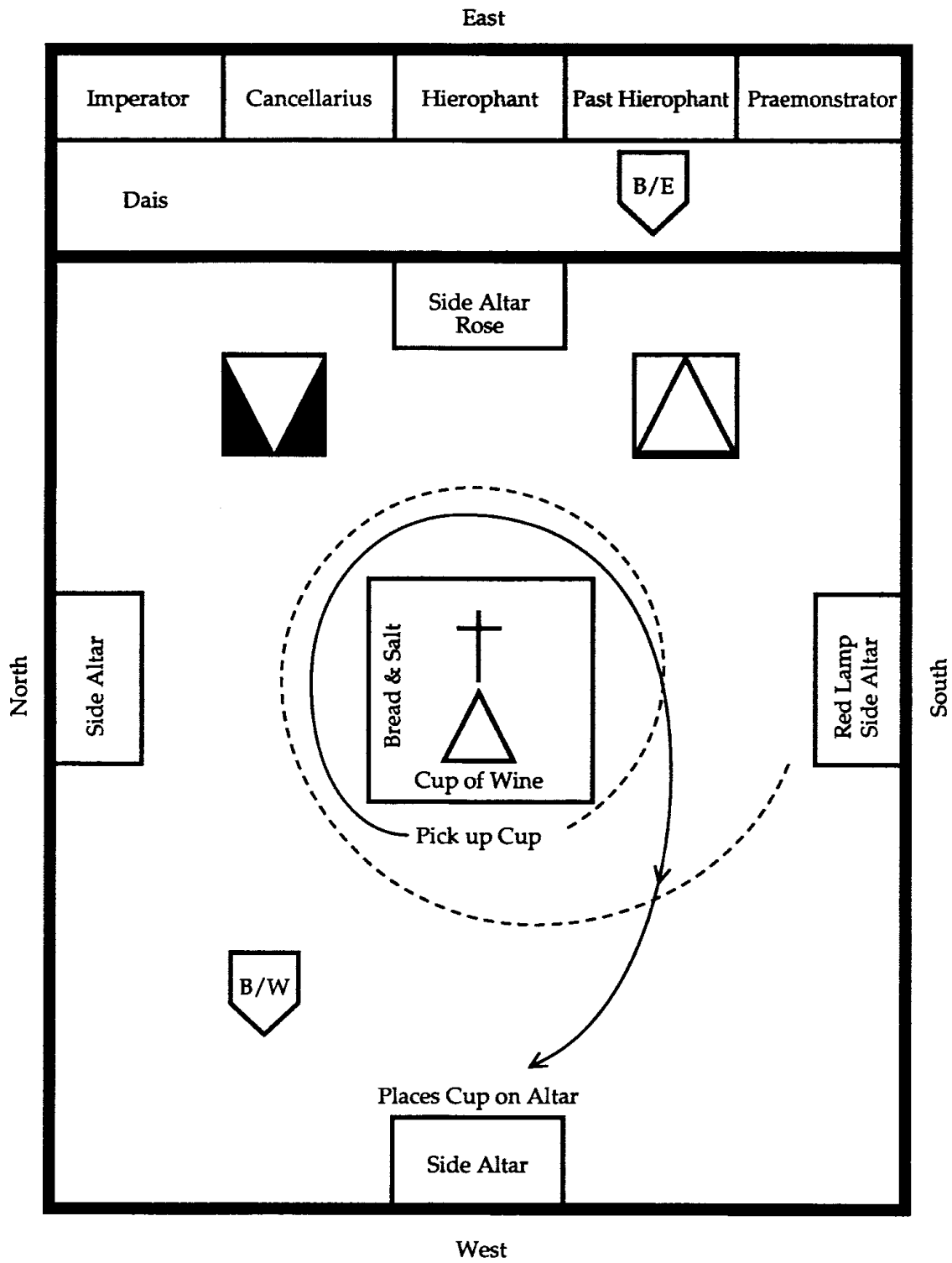

Figure 57
Circumambulation of the Kerux from South to West

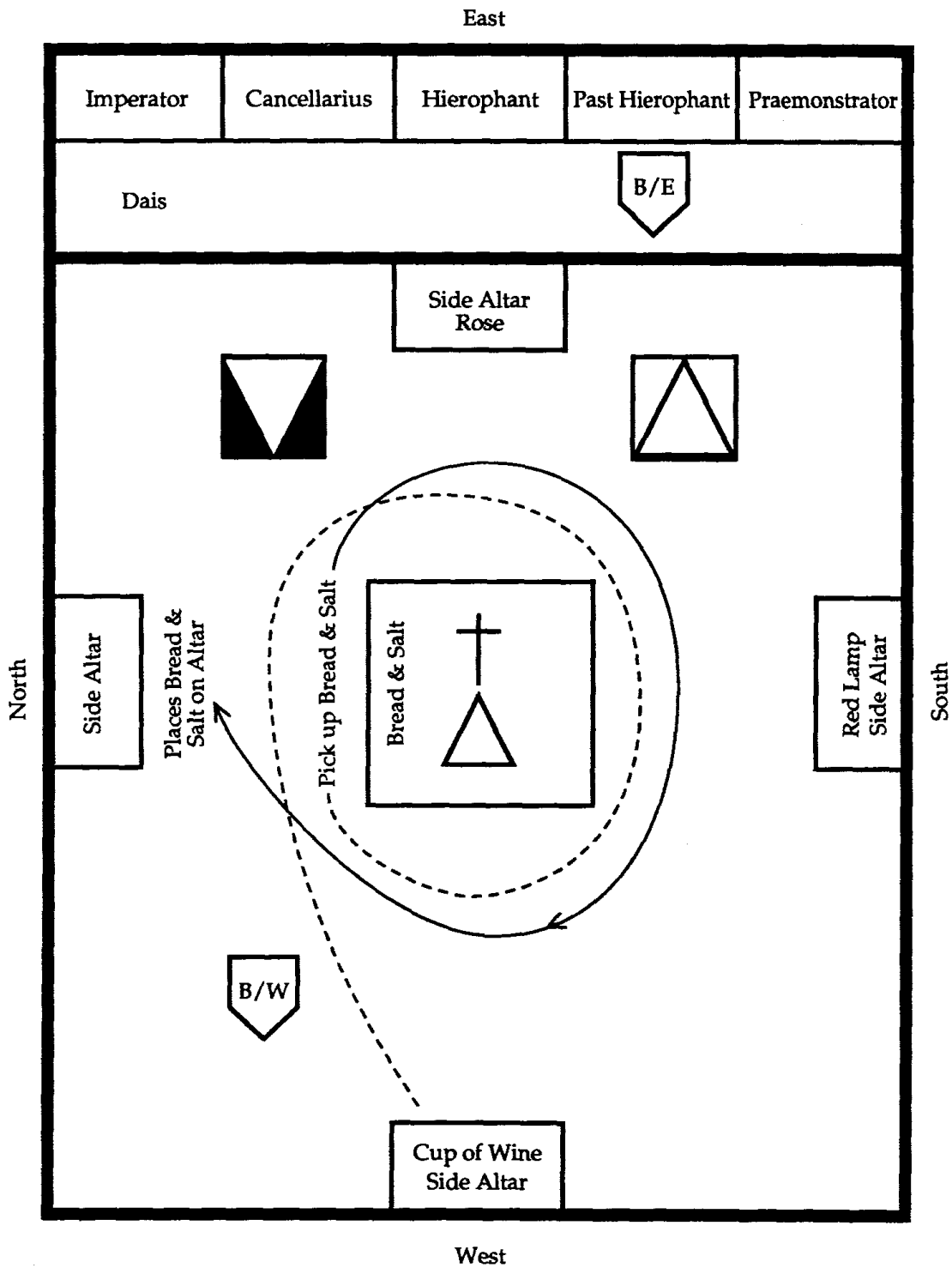

Figure 58
Circumambulation of the Kerux from West to North

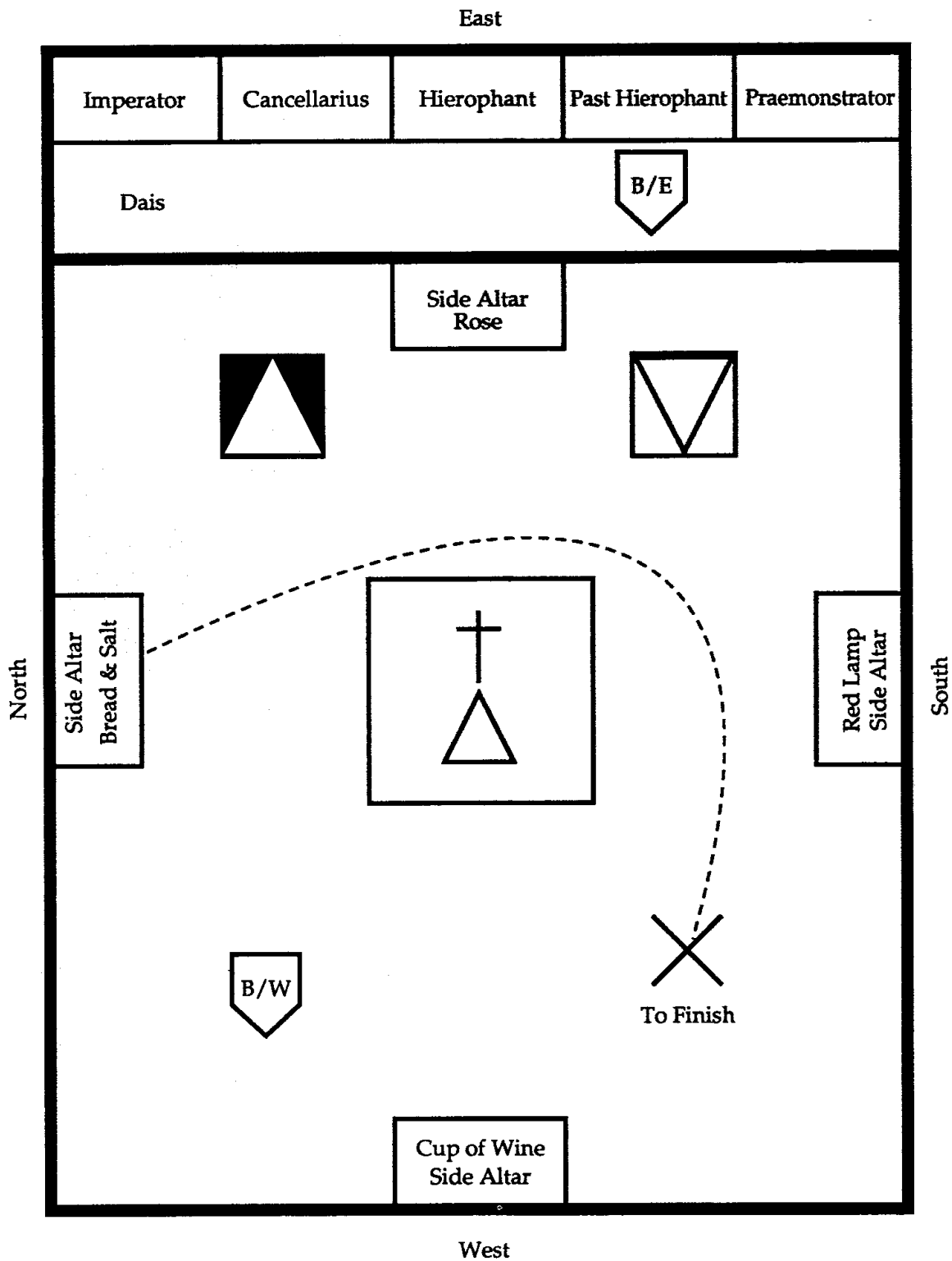

Figure 59
Cikrcumambulation of the Kerux — Finish

through the magnetized process of ritual. Dion Fortune, in her book *Psychic Self Defense*, claimed that the 0=0 ritual she experienced actually repaired her vitality. Many others have made similar claims here in New Zealand and in England. When the implements are taken from the Altar, the corresponding process taking part in the Candidate is fundamentally one of removal—of the etheric blockages in the aura, so that it becomes attuned to that of the ceremony; for the Candidate is controlled by the temple officers long before he or she enters the Hall. The current that they work under is the Osirian one, through the imagery of the Hall of the Two Truths, for this allows the Order access to the Higher Self, who must stand apart from the Candidate, during part of the ceremony. Taylor often stated that the placement of the implements is vital to the success or failure of the ceremony. Not only must they be placed in their respective directions, but they must link correctly to the God-forms that they represent as well. Though the Canopic Gods are in the corners of the Hall, it must be remembered that they cover an entire area, between each cardinal point, and thus are placed centrally between the two.

The spirals initiated by the Kerux are extremely important, for, when done correctly, they draw the power from the central Altar and link it to the cardinal points. This is not to be confused with the actions of the circumambulation which gives the Rise of Light. This is distinctly different, as the circumambulation allows the Light, or the current vibrational pitch, to enter the body of the officers, stimulate the etheric body of the Candidate, and help open the temple. The spirals expand the consciousness of the Candidate through the Osirian current or influence so that the symbolic parts of the Candidate can be removed correctly and without damage. Taylor quoted a case where the Kerux at Whare Ra, during one 0=0 ceremony, accidentally dropped the Paten in the South. After the ceremony, the Neophyte had an inflamed intestinal disorder that was a mystery to the doctors. When Felkin heard of this, he did a small ceremony involving the replacement of the Paten, and, within an hour after the ceremony, the intestinal pain and disorder ceased.

Apart from the etheric influences directly on the body of the Candidate, the implements on the Altar represent the component parts of the Ruach, analogous to the Will (Rose), Memory (Cup), Reason (Paten & Salt), Desire (Lamp), and Imagination as the component part which holds all together (the Altar). This is the start of the dismantling of the bondage that the Ruach has over the Candidate and allows the Light of the Neshamah to illuminate the mind.

Symbolism of the Admission of the Candidate

Preparation of the Candidate

The Candidate is waiting without the Portal under the care of the Sentinel—"The Watcher Without"—that is, under the care of the form of Anubis of the West, symbolically called that so that he' may keep off the "Dog-Faced Demons," the opposers of Anubis, who rise from the confines where matter ends to deceive and drag down the soul. The Ritual of the 31st Path says:

... since, ever dragging down the Soul and leading it from the Sacred Things, from the confines of Matter arise the terrible Dog-faced Demons, never showing a true image unto mortal gaze.

The real link of the Candidate, with the Order, comes through his or her application to join the Order. This fine etheric thread becomes the link, with the Candidate, that enables the subtle centers to be manipulated by the ceremony going on within the main Hall.

The Hegemon, the representative of the Goddess of Truth and Justice, superintends the preparation and symbolism. She is the Presider of the Equilibrium and administrates the process of

Throughout this chapter, the masculine pronoun is used in its generic sense to indicate either sex.

equilibrium in the Candidate himself through the symbols of rectitude and self-control.

The actual preparation of the Candidate should be performed by the Sentinel—the "Watcher Without"—to insure that this preparation is accomplished so that the establishment of equilibrium can occur. Therefore, the Hegemon superintends the preparation rather than actually performs it.

A triple cord is bound around the body of the Neophyte, symbolizing the binding and restriction of the lower nature. It is triple in reference to the White Triangle of the three Supernals.

The eyes are bandaged to symbolize that the Light of the material world is but Darkness and illusion compared with the radiance of the Divine Light. The preparation also represents a certain temporary binding and restriction of the natural body.

The Candidate's Entrance into the Hall

The single knock given by the Hegemon outside the door represents the consenting will of the natural human to receive the force formulated by the Hierophant. It is answered by the Kerux inside, as if a witness were confirming the same. This being done, the Kerux, as a witness, demands authority from the Hierophant to admit the Candidate into the Hall of Truth and Justice. The Hierophant, granting permission, seals the Candidate's aura with a new name given to the physical body of the outward man but signifying the aspirations of its soul.

When the Candidate enters the Hall (normally from the West), he becomes a cornerstone of a triangle. The Hegemon is opposite and level with him. The Sentinel is behind them making up the tip of the triangle. At this juncture, it is important to remember that the Portal of the ceremony does not stretch to the four walls of the Hall, but rather resembles a spherical shape. The exact size of it depends on the Hall, but there are normally quite a few feet around the edge where members not taking part sit and view the ceremony. In front of the triangle, without the Portal, an identical triangle just inside the Portal is formed by the Kerux, Stolistes, and Dadouchos, as shown in Figure 60.

The Portal becomes the separating point between the two

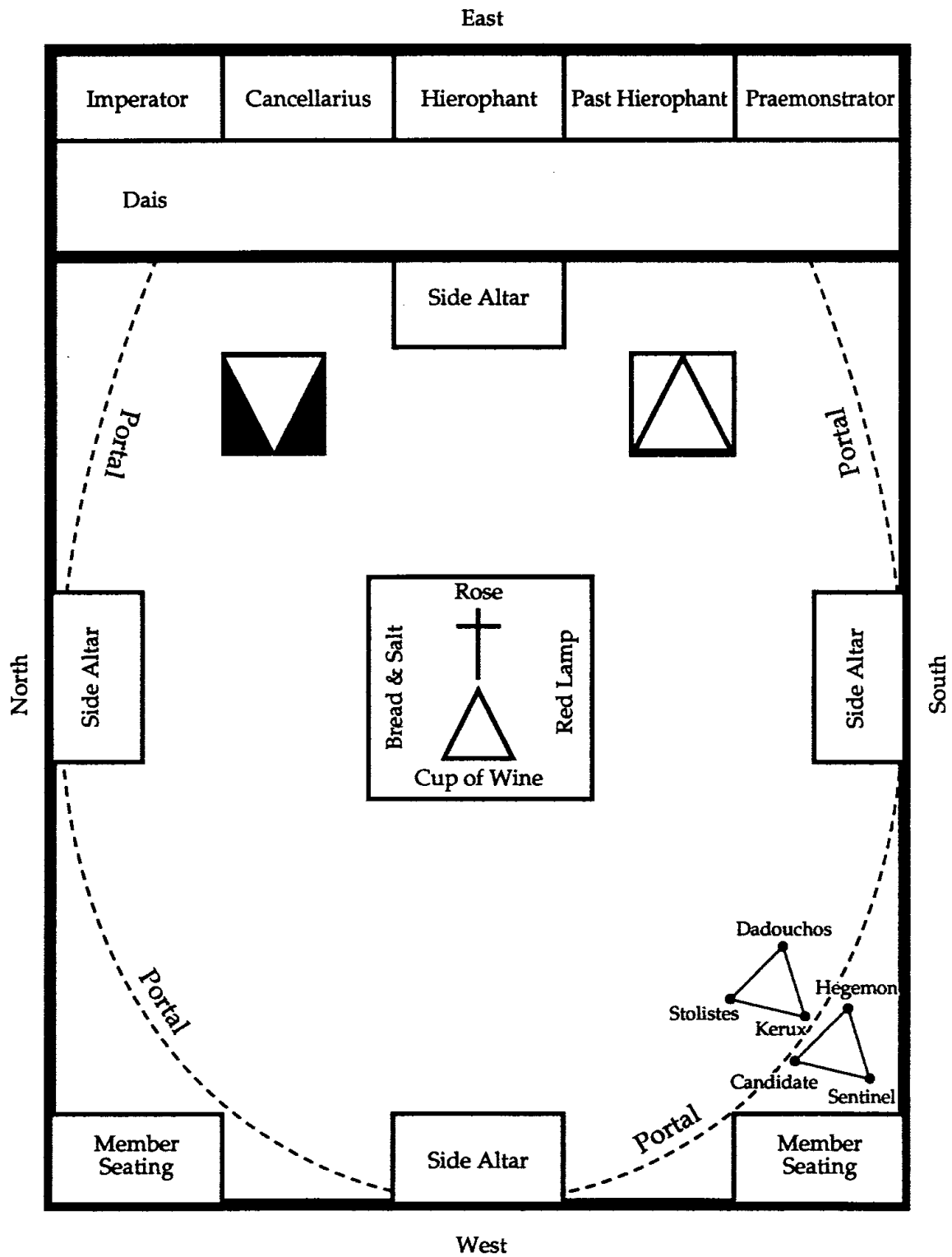

Figure 60
Entrance of the Candidate

triangles. Particular attention must be made to the rim of the Portal, for no officer is to go outside it. To breach the Portal during the ceremony opens it to negative influences. Crossing over from one side to the other must be done correctly. The Hegemon is the only one who can do this during the ceremony, because she is another one of the forms of Maat, part of the basic essence of the formulation of the Hall itself. One can only ascertain exactly where the Portal is through experience, though in practice it is easily found and detected by a heat sensation that is usually about 12 inches in diameter.

To bring the Candidate over the Portal, the Hegemon must first have him consecrated while he stands on the band of the Portal itself. This alters his already attuned aura so that it will balance with the energy within the Portal.

The Kerux instantly bars the Candidate's passage to mark that, though he has been admitted, the natural human being of unpurified desires cannot be a dweller in the Hall of Truth. The consecration immediately calls into action the Pillars of the Candidate's own Sphere of Sensation. This is the first of four consecutive consecrations because, when the Pillars of the Tree are projected onto the Sphere of Sensation, there are four Pillars, of which the Middle Pillar is the axis. The external Pillars represent the boundaries of the aura. The central Pillar represents the subtle body centers, or the minor chakras, situated on the front of the body (these are grouped Kabbalistically), but the main seven chakras are not directly stimulated.

The Hegemon uses her Ruach to stimulate that of the Candidate. At this point in the ceremony, the astral appearance of the Candidate is that of a form wrapped in Darkness, as if extinguished thereby, and having unto his right, and unto his left, the faint semblance of the two Great Pillars of Fire and of Cloud from which issue faint rays into the Darkness which covers him.

Immediately above his Sphere of Sensation, there will appear a ray of bright Light, as if preparing to penetrate the Darkness covering him. The result of this will be that the Candidate, during the whole Ceremony of Admission, will usually appear to

be somewhat automatic and vague. This is not unlike the Indian guru helping a student by giving him some energy so that certain blockages can be removed, but on a much lower scale.

The break in the Portal, caused as both the Candidate and the Hegemon cross over, is held in check by the Kerux with the help of the Stolistes and Dadouchos, who use their energy to focus on closing the opening after the crossing.

Another point of significance is also made apparent by the Candidate, dressed in black, representing the dark untrodden Path, and the Hegemon, in white, representing the illuminated way. The Candidate and the Hegemon enter the darkest part of Malkuth and they walk to the lightest part, citrine. The doctrine is that, in Malkuth, there are four Kabbalistic Trees of Life, each related to a letter of YHVH—or simply the Four Worlds applied to Malkuth. The Candidate must go from the Malkuth of Assiah (Heh) to Malkuth of Atziluth (Yod).

Now the Hegemon, throughout the ceremony, acts as a guide, prompter, and answerer for the Candidate. Her office with regard to the Candidate is analogous to that of the Candidate's Higher Soul—wherefore also the Hegemon holds in her hand the miter-headed scepter, to attract, *since* it is the Scepter of Wisdom, the Higher Self of the Candidate.

At this moment, as the Candidate stands before the Altar, as the simulacrum of the Higher Self is attracted, so also arises the form of the Evil Persona of the Candidate—and were it not for the power of the 42 lettered name in the Palaces of Yetzirah (the gods of which name being usually called the "Great Assessors of Judgment"), the actual Evil Persona would at once formulate and be able to obsess the Ruach of the Candidate. For, seeing that at this time the simulacrum of the Higher Soul is attracting the Neschamah of the Candidate, the human will is not as powerful in the Ruach for the moment because the Aspirant of the Mysteries is now divided. That is, his Neschamah is directed to the contemplation of his Higher Self, attracted by the Hegemon. His natural body is bound and blinded, his Ruach threatened by the simulacrum of the Evil Persona attracted by Omoo-Szathan, and a species of shadow of himself thrown forward to the place of

the Pillars, where the Scales of Judgment are set. At the same time that the first consecration establishes a semblance to the Pillars on his right and left, it also has drawn forth from him a semblance of himself to the place vacated by the Hegemon between the Pillars.

Here, then, stands the shadow of the Candidate while the Scales of the Balance oscillate unseen. Unseen and colossal, there is imaged before him Tho-oth, as Metratron, in the Sign of the Enterer of the Threshold. He is ready, according to the decision of the human will, to permit or withhold the descent of the Lower Genius of the Candidate.

The Obligation of the Candidate

The Obligation of the Candidate has three major functions. The most obvious one is towards the preservation of the Order's anonymity through secrecy. The next level is the binding process that submits the Candidate as part of the new-found Order, which in many ways is a form of esoteric discipline. The final, and deepest phase, is the action or effect the Obligation has on the Candidate through the actions of the Ruach.

When the right hand is placed within the triangle on the Altar, the Ruach is then controlled by the Will—through the operation of Geburah (through Elohim Gibor and the Archangel Kamael), and the vibration of this Sephirah within the Candidate. The Will, under this Archangel's direction, then helps with the force to which the Candidate has bound himself. In simple terms, the Will acts as a type of subconscious police force.

Now a great deal has been said of the Golden Dawn Neophyte Obligation. Taylor taught us that an Oath such as this was in reality up to the dictates of one's own conscience. Some have considered the Obligation as a symbol of the Lightning Flash coming down the Tree of Life, which descends into the aura, but, in effect, no such thing happens. The Obligation binds the Candidate to his Higher Self. As Aleister Crowley put it, the Obligation affirms the very existence of the devotee, and that is inherent in our survival instincts; i.e., not to put ourselves at anyone's mercy whether the person be in the Order or not. The

Obligation activates man's affirmation of his existence, as linked with a form that is beyond the sense of the self to fully comprehend, thus pushing it deep into the layers of the self.

Clairvoyant observation of the Candidate during the Oath shows that a red ray of Geburah is produced in the Sphere of Sensation of the Candidate. This is a combination of fear and martial discipline. The Obligation of the Neophyte uses the will, through the faculty of the imagination, to link other parts of the Ruach together. Also, when the Obligation is taken, the Higher Self stands in the Station of Harpocrates, the God of Silence, whose form is to protect the Candidate from the Evil One in front of him. Once this silence is broken, the Evil One can then take over as the protection of Harpocrates is withdrawn.

Meanwhile, the Great Assessors of Judgment examine the truth of the accusations formulated by the evil and averse antithesis. The Assessors of Judgment come not under the head of the Invisible Stations, but, during the Obligation and Circumambulation of the Candidate, until he is brought to the Light, they hover immediately about the limits of the Portal, with their evil antithesis immediately below. Therefore, when the Candidate stands before the Altar prior to the Obligation, the decision is actually taken by the human will of the Candidate. He sees a disintegration of his component parts. The process of symbolic judgment takes place during the speech of the Hierophant to the Candidate, the answer of the Hegemon, and the Candidate's consent to take the Obligation.

The moment the Candidate consents, the Hierophant advances between the Pillars as if to assert that the judgment is concluded. He advances by the Invisible Station of Harpocrates to that of the Evil Triad. He symbolically stomps down so that, as Aroueris, he stands upon the opposer. He then comes to the East of the Altar, interposing between the place of the Evil Triad and the Candidate. At the same time, the Hierophant advances on the Candidate's left. The Hegemon, on his right, formulates about him the symbol of the Higher Triad before she places his hand upon the symbol of the Three Supernals lying upon the Altar. Again, before doing so, he has been bidden to kneel in

adoration of that symbol, as if the natural man abrogated his will before the Divine Consciousness.

As he kneels in the presence of the Triad of Aroueris, Thmaa-est, and Horus, he places his left hand in that of his initiator to affirm his passive reception of the ritual. His right hand is on the white triangle as a symbol of his passive aspiration towards his Higher Self. His head is bowed to represent the voluntary submission of the human will to the divine—and for this latter reason he repeats in the Obligation his name in the Outer World.

A very important part of the Obligation is the use of the sword by the Hieres. In the hands of an untrained officer, more harm than good can be caused. This is yet another reason for the temple officers on the floor to be all Inner Order members.

There were at least three people at Whare Ra Temple that had their clairvoyant abilities removed after the sword touched the nape of the neck. One person who could see auras to a high degree lost this ability immediately and was told by his Seniors that it would come back better than before—something which did not happen. Twenty years later, another identical case occurred. Taylor recalled its happening a number of times. Since the discipline at Whare Ra regarding excellence was quite strict, one can only come to the conclusion that the officer of Hieres had not performed his function correctly, in the field of magnetic manipulation, at this vital moment in the ceremony. While a few lost clairvoyant abilities, quite a number gained them; and, as the sword of the Hieres was placed at the nape of the neck, a distinct click could be heard by those around the Candidate. This was usually considered a sign that this part of the ceremony had been done well.

Taylor maintained that a good Hierophant should always meet the Candidate informally and study his aura to see if there were any abnormalities in it so that incidents of lost clairvoyance could be avoided. In one incident recalled by Taylor, he actually refused to do a 0=0 ceremony because he read indicators of mental imbalance in the Candidate's aura. (This caused quite a stir at the time.) The individual was put through some time later by

another Hierophant, and Taylor's predictions proved correct some months later when the individual was placed in psychiatric care. When individuals showed natural clairvoyant abilities during the Obligation, Taylor would always reinforce the Candidate's aura with his own magnetism to prevent the incorrect use of the sword in the hands of an inexperienced Hieres.

The Hierophant gives one knock, affirming that the submission unto the Higher Self is perfect. Only at this moment does the invisible and colossal figure of Tho-oth cease to be in the Sign of the Enterer and give the Sign of Silence, permitting the first real descent of the Genius of the Candidate, who descends to the Invisible Station of Harpocrates as a witness of the Obligation.

The Hieres and the Hierophant return to their thrones, and therefore it is not Aroueis, but Osiris himself, that addresses the speech to the Candidate—"The Voice of My Higher Self," etc., which confirms the link established between the Neschamah and the Genius by formulating the conception thereof into the Ruach. For this, Osiris speaks in the character of the Higher Soul, the symbolic form of which is standing between the columns before him. The affirmation of the Higher Soul as the god of the human being does not mean that this is the only God. Rather, it indicates that it is the only presentiment of Him which the natural human being can grasp at all. Neither is it just to say that the Higher Soul is one with God, seeing that the part is by no means the whole; nor can the whole be accurately and sufficiently described as an assemblage of parts. Let not the reverence for the God of thy self cause thee by a misconception to lose thy reverence for the Gods who live forever—the Aeons of Infinite Years. Herein is a great error, and one which may, in its ultimatum, bring about the fall of the genius. This is a sin which entails none the less terrible consequences because it is a sign of the Higher Plane, where the choice is not between good and evil but between the lower and higher forms of good.

The Circumambulation of the Candidate

In the first spiral of the Circumambulation, knocks are given in the East and West only. The concept here is to instill in the Candidate a sense of equilibrium, for those knocks which signify the Middle Pillar of balance represent the central axis of the Tree of Life in the ceremony. More importantly, though, it activates the realization of the Middle Pillar within the body of the Candidate himself. This subtlety teaches the Candidate focalization (this form of awareness was never intended to be instantaneous, but should develop over the ensuing months between the Neophyte and the Zelator grade). Therefore, the Mystic Circumambulation in the Path of Darkness led by the Kerux with symbolic Light formulates the Higher Soul, which is not the only Divine Light, but rather a spark from the Ineffable Flame. The Kerux, in his turn, is but the Watcher of the Gods.

After the Kerux comes the Hegemon, the translator of the Higher Self, leading the Candidate. Then come the Goddesses of the Scales of the Balance, the Stolistes and the Dadouchos. They move once round; the formation in the Darkness of the Binah angle of the White Triangle of the Three Supernals. The Hierophant knocks once as they pass him, in affirmation of Mercy—the Hiereus in affirmation of Severity; and the invisible Assessors each give the Sign of the Enterer as the Candidate passes on the way. At the second passing of the Hierophant, the knock affirms the commencement of the angle of Chokmah.

The first barring of the Candidate, on the second spiral, by the Kerux, is extremely important, for while he bars the gateway to the West, he actually does so in the South. This represents a further division of the spiral. The red (Shin) part of the Kerux's wand is placed firmly in the Candidate's Tiphareth center, working directly through his Ruach to stimulate and attract the current of the Chiah into direct operation. To perform this function correctly, it cannot be done by someone in the Outer Order (yet another argument for Inner Order members for temple floor officers). The Kerux, according to the Z.3, uses his Magic Staff of Power to represent a ray of Divine Light which kindles the Hidden Fire. The Red Ray of the Kerux, through his

Ruach, goes through directly to the Ruach of the Candidate by the power of the fiery part of the Wand. The Kerux Grips the Wand in the yellow (airy) band. This shows that he is in control of his own Ruach; then he directs it to the Chiah by the power of the Secret Fire.

The caduceus lamen that he wears also has a part to play which goes beyond mere symbolism. Its function is to balance the energy directed by the Kerux, and it is placed directly over the Kerux's Tiphareth center, analogous to his Ruach. Any emotive force of a disruptive nature is held in check by this. Also it controls the amount of energy with which the Candidate is stimulated.

The consecration by Fire and Water is more than a simple consecration. The positioning of these officers in relationship to the Candidate is always in the form of a triangle.

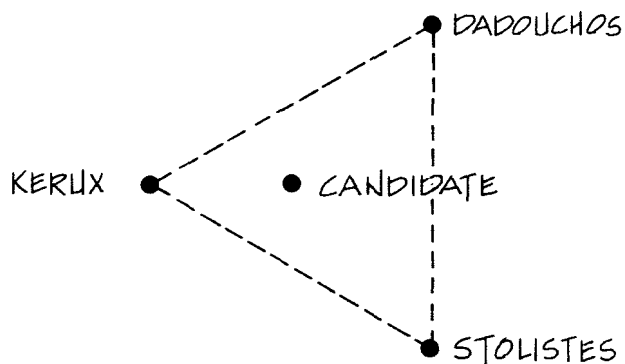

*Figure 61
The Barring of the Candidate*

The barring is shown in Figure 61. Figure 62 shows the Consecration by Fire.

The Kerux retains his position while the Stolistes and Dadouchos move up together so they are both alongside the Candidate. Then they turn 180 degrees to face him, still maintaining the triangular position around him. During the consecration by Fire, the Dadouchos slightly turns the Candidate towards her, but not enough to disrupt the pressure of the

The Sealing of the Candidate's Aura

After the Circumambulation, the Candidate passes to the Altar of the Universe, which receives the influences of the three Pillars. It should be as though the ray from the Divine would descend into the darkness of the mind, for then, but not until then, is he fitted to realize what are the first things necessary to the "Search for the Shining Light."

As the Hierophant advances along the Path of Samekh, he represents the Divine Light coming through the Ruach of the Candidate. He pauses briefly between the Pillars, and his form is stabilized by the Goddess of the Scales, as she also represents the Holy Guardian Angel (a title sometimes analogous to the Tarot Trump "Temperance" in its archetypal representation), the perfected man. When the Hierophant reaches Yesod, he again pauses. Here the Hierophant, as the descending Light of the Order, enters the Candidate's Nephesh through a direct magnetic link. As he stands on the station of the Evil One, he takes control of the Nephesh and pushes aside any negativity, so that the Light draws in the Light from above to the Candidate while the Banner of the East reflects it in the temple (Figure 63).

The form of Harpocrates now formulates a protective envelope around the Candidate, which draws forth the Higher Self of the Candidate, for the negative influences (now under the control of the Hierophant) cannot harm it. The Hierophant gives a single knock to seal the matter and then invokes the Lord of the Universe. Then only is the hoodwink removed. The Hierophant, Hieres, and Hegemon join scepters and sword above the Candidate's head, thus formulating the Supernal Triad, and assert his reception into the Order. They then recite the mystic words to seal the current of the Flowing Light. This is the point where the magnetic influences of the three officers work together, and they direct their influence to the aura of the Candidate. The energy of each implement vibrates so that, at this point, a triangle of Light can be seen (clairvoyantly) above the Candidate's head. This is brought to a fine point with the words "KHABS AM PEKHT—KONX OM PAX—LIGHT IN EXTENSION."

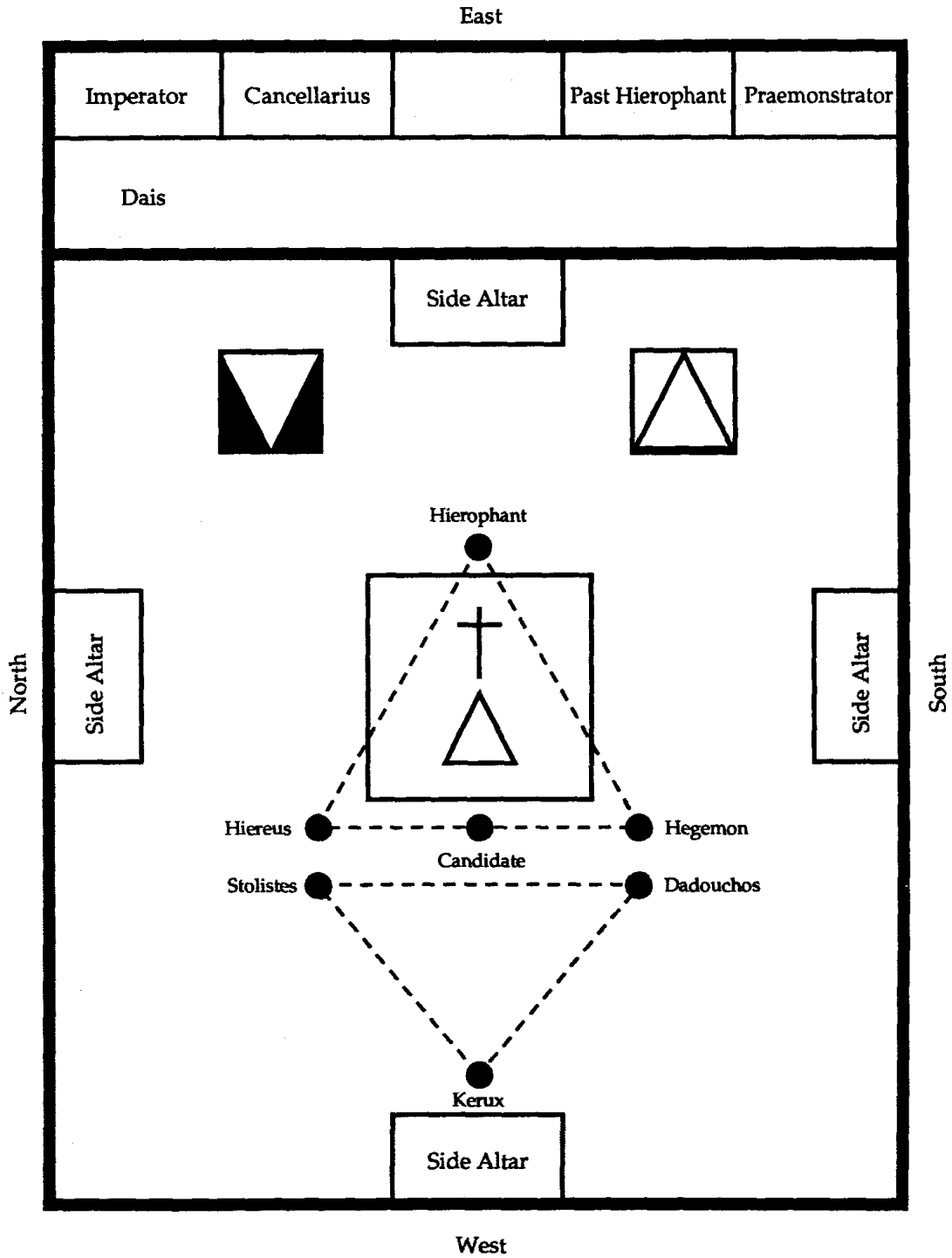

Figure 63
Sealing the Aura of the Candidate

The Hierophant now calls forward the Kerux, cautioning the Candidate that the light has preceded him without his knowledge. It represents to him here a vague formulation of ideas which as yet he can neither grasp nor analyze. This light is not a symbol of the Higher Self, but a ray from the Guardians of the Order themselves.

Only after having thus been brought to the Light is the Candidate led to the East of the Altar—the place of the Station of the Evil Triad—to affirm that with this Light, he will be able to cast out and trample on his Evil Persona, which, when it has been put in its place, will then become a support to him. It is to the Hiererus, "Avenger of the Gods," therefore, that the duty of entrusting the Candidate with the Secret Signs and so on is delegated. It is he who places him for the first time between the Pillars and superintends his final consecration—thus bringing the peculiar force handled by the Hiererus to the aid of the Candidate so that he may more safely and resolutely combat the temptations of the Evil Persona.

The Hierophant has returned to his throne while the Hegemon holds the insignia of the Hiererus while he confers the Signs, etc. She thus affirms to the Candidate the necessity of the force represented by the Hiererus.

The Hierophant on the throne, the Hiererus East of the Black Pillar, and the Hegemon East of the White Pillar again form a Triad, which here represents the reflection of the Three Supernals. The Higher Soul is formulated between the Pillars in the Place of Equilibrium. The Candidate is in the place of the Evil Triad, and the Hiererus now advances to the place of Harpocrates between the Pillars to give the words.

The Instruction of the Candidate

The symbolism and meaning of the Step, Signs, Grip, or Token, and the Words have a threefold interpretation:

1. Apparent meaning.
2. Spiritual or mystical reference.
3. Practical application.

Each is therefore considered under three headings.

First, the foot is advanced about six inches. This represents the foot on the side of Chesed being put forward and taking a hesitating step in Darkness. The left foot is used to represent the power of Isis, or the beginning of action, rather than Nephtys as the end thereof. The distance of "six inches" is employed here only to render it more intelligible to modern initiates. It means a convenient measure of six, and preferably six times the measure of the phalanx of the thumb—the Spirit and Will.

Second, it symbolizes the beginning of the stamping down of the Evil Persona. The foot is advanced six metrical distances, answering to the number six of Tiphareth—Osiris—alluding therefore to the self-sacrifice necessary to accomplish this.

Third, it represents the practical application of the beginning of a magical force. Let the Adept, in using the Sign of the Enterer, give the step as he commences the Sign and let him take that step as if he stamped upon the Earth, and the Earth quaked and rocked beneath him. As it is said, "Clouds and Darkness are round about Him—Lightnings and thunders the Habitation of His feet." Its secret name is "The Step of the Avenger."

Saluting Sign

1. That of groping forward in search of truth.
2. It represents the involution and bringing forward of the Light into the material to aid the will of the Candidate in his search for and aspiration towards the Higher.
3. Standing as before described, in the form of the god, and elevating the mind to the contemplation of Kether, take the step like a stroke with the foot, bring the arms up above the head as if touching the Kether, and as the step is completed bring the hands over the head forward. Thrust them out directly and horizontally from the level of the eyes—arms extended, fingers straight, palms downward, the hands directed toward the object it is wished to charge or to affect. At the same time, sink the head till the eyes look exactly between the thumbs. In this way, the rays from the eyes, from each finger, and from the thumb must all converge upon the object attacked. If any of them disperse, it is a weakness.

Thus performed, this Sign is a symbol of tremendous attacking force and of projection of will power, and it should be employed in all cases where force of attack is required—especially in charging talismans and the like. Generally, it is best to have the thumbs and all the fingers extended—but if a particular effect is desired, you may extend only the fingers appropriate thereto, keeping the rest folded back in the hand. Herewith also may be combined the attribution of the planets to head (Mars to the right nostril, Mercury to the mouth, etc., as explained in the Microcosm lecture), sending at the same time an imaginary ray of color of the planet desired from the part of the head attributed to it. But, when finished, be careful to withdraw the rays again or they will remain like so many outlets of astral force and thus exhaust you. The best way to protect yourself against this is to give the Sign of Silence immediately. For the first Sign should always be answered by the second. The secret names of the Saluting Sign are "the Attacking Sign" or "the Sign of the Enterer of the Threshold."

The Sign of Silence

1. This is simply that of secrecy regarding the Mysteries.
2. It is the affirmation of the station of Harpocrates, wherein the Higher Soul of the Candidate is formulated in part of the admission ceremony. It is the symbol of the center and of the "Voice of the Silence," which answers in secret the thought of the heart.
3. The Sign of Silence withdraws the force put out by the Sign of the Enterer. Take upon thyself as before taught the colossal figure of the god, Harpocrates. Bring the left foot sharply back, both heels together. Beat the ground once with the left foot as it is placed beside the right. Bring the left hand to the mouth and touch the center of the lower lip with the left forefinger. Close the other fingers and thumb and drop the right hand to the side. Imagine a watery vapor encircles you. This is the reflux of the current.

This Sign is also used as protection against attack. The Sign represents a concentration of astral Light about the person.

Having given the Sign as above, it is a protection against all attack and danger of obsession. To make it stronger, the form of the god should be taken. If spiritual force is required, formulate as if standing on a lotus or rising from it. For force in contemplation and meditation, formulate as if seated upon a lotus. But for more material force, imagine standing upon a dragon or a serpent like some statues of Harpocrates. As a defense and protection, the Sign is as strong as the Banishing Pentagram, though different in nature. And as the Sign of the Enterer represents attack, so does this Sign represent defense thereto, as a Shield is a defense against the Sword. From this Sign is a formula of invisibility derived. There is a story told by Dr. Edmund William Berridge, who was a prominent member of the Golden Dawn:

A few years ago I noticed that invariably after a prolonged interview with a certain person I felt exhausted. At first I thought it only the natural result of a long conversation with a prosy, fidgety old gentleman, but later it dawned upon me that being a man of exhausted nervous vitality, he was really preying upon me. I don't suppose that he was at all externally conscious that he possessed a vampire organism, for he was a benevolent, kind-hearted old man who would have shrunk in horror from such a suggestion. Nevertheless, he was, in his inner personality, an intentional vampire, for he acknowledged that he was to marry a young wife in order, if possible, to recuperate his exhausted system. The next time, therefore, that he was announced, I closed myself to him before he was admitted. I imagined that I had formed round myself a complete investure of odic fluid, surrounding me on all sides but not touching me, and impenetrable to any hostile currents. This magical process was immediately and permanently successful—I never had to repeat it.

The "odic fluid" that Dr. Berridge mentions is the same as "an encircling and enclosing watery vapor." This may be done effectively in the astral as well as physically.

The Secret Names of this Sign are "The Sign of the God of Silence" or the "Sign of Defense or Protection." It may be performed with any finger of either hand, but it is most protective

when the left forefinger is used, the Water of Chesed, for the fingers of the right hand represent more violent action, and those of the left more watery action. With regard to taking on mentally the forms of the gods, it may be here noted that the process is of great assistance and use in all magical workings, whether of invocation or evocation, contemplation, meditation, skying in the spirit vision, alchemy, and so on. For the forms of the gods do here represent a certain symbolic material action of the divine forces.

The Sign of the Silence is done after the Sign of the Enterer because it stops the force one activates with the initial Sign. The reason that three Signs are done is to build up more power, but they are all always stopped when the Sign of Silence is given.

During the Circumambulation, when the Sign of the Enterer is given, it is to a certain extent a blind force, for here the energy is expended out only to fortify the outward spiral (under the old regime, it was the circle; going outside the Pillars the same principle was applied) and the energy here expended emanating through the aura as the individual goes around the Altar, but is not given a boost or directed until one arrives at the throne of the Hierophant. The Sign of Harpocrates, given straight after it, seals this force back into your aura so no leakages can occur. This is done a number of different ways, though the Invisible Station of Harpocrates is its power source. For this is where the first Circumambulation is done, nearest the Altar, and it expands out with every turn.

In our own training in the Sign of Silence and its uses, Taylor gave us an example of an individual who did the Sign of the Enterer, and, during the Circumambulation, had energy leaking out of him like a sieve (which Taylor observed through his remarkable clairvoyant ability). This was only rectified when the Sign of Silence was done. Taylor later found that the individual had suffered a personal loss that same day, but had decided to do the ceremony to gain strength from it.

It should be pointed out here that the temple members observing the ceremony, but not taking part in it, should join in the Circumambulation of the temple officers. The Sign of Silence is done in the Astral Form of Harpocrates from its original

position. The power of this god-form draws out towards the East, pulled there by the *kavanah*, or "intent," of the first Circumambulation. The other times it is done, this god-form expands and pushes along the spiral of the Circumambulation. The energy from this is from the Altar, for this is where the power comes from (within the Circumambulation). The throne and Dais of the Hierophant and other seated officers are limited here. Their power has already charged the temple and activated the Altar. The whole concept is an example of the current of Horus working with that of Osiris.

The Grip

1. The steps are taken and the Grip is exchanged simultaneously. Together, this means seeking guidance in the Darkness and silence of the Mysteries.

2. It shows that a steady and resolute will, acting in union with good, will accomplish what it desires no matter how often it fails at first. It inculcates the necessity for harmony and brotherly love—of doing away with pettiness and too much self concentration—for allowances for the weaknesses of others within limits—of shunning resolutely anything in the nature of slander. So that, in the Grip of the Neophyte, the Initiates meet hand to hand and foot to foot in the true greeting of brother and sister, and not in the veiled hostility of an enemy. For, in the working of the Inner, where all invoke the same forces in the same manner, if he becomes unsympathetic with the rest and so separates himself from them, though he weakens the combination of working, yet he still more certainly attracts upon himself a reflex current from the Avengers of Evil.

The name of Silence, which is the Grand Word of this Grade, also represents the Silence of the Sacred Mysteries to be observed toward the Outer Order. It shows also the necessity for respect towards the secrets of any Frater or Soror committed to your care, not endeavoring to search them out for the purpose of curiosity, not repeating them when discovered, nor in any way referring to them as a means of causing humiliation, but to keep them as sacred trust and not to be deflected by them from acting

justly and harmoniously together.

3. In any magical ceremony or other working, if more than one member is taking part, all present putting themselves into the form of the god as taught should exchange Sign, Grip, and Words, so as to establish a current of harmony and the affirmation of a mutual direction of will toward the same object.

The Password

1. The password merely guards the Secrets of the Order against any members resigned or not working; hence it is changed each Equinox.

2. It is an affirmation of the different spiritual, as well as the different physical, constitutions of the Candidates—that all nature cannot be the same without evil and injury resulting thereby—but that each nature should be brought to its own Kether—the best of its kind. This, too, may be done in all things. It is the basis of Alchemy.

3. It should be pronounced as if attracting the solar force, the Light of Nature, during the six months following the Equinox at which it is issued, as a link with the solar force, between that and the Order. This password, therefore, may also be used in a magical ceremony as attracting the support of the Light of Nature acting upon natural forces.

After giving the words and signs, the Hieres draws the Candidate forward between the Pillars and, for the second time in the Ceremony, the Higher Soul stands near and ready to touch the Candidate. The Hieres returns to his place East of the Black Pillar so that the three chief officers may formulate and draw down to the Candidate, by their insignia and other influence of their symbols, the forces of the Supernal Triad. It is important, therefore, that, at this point, they should be in these places.

The Candidate now stands between the Pillars, bound with a rope like the mummified form of Osiris between Isis and Nepthys. The final consecration now takes place by the Goddess of the Scales of the Balance. The Candidate now stands, for the first time during the ceremony, at the point representing the equilibrium of balance. Meanwhile, the Kerux goes to the North,

ready for the Circumambulation, so as to link that with the final consecration of the Candidate.

The final consecration is also demanded by the HieresHoru the powerful Avenger of Osiris, as still menacing the Evil Persona of the Candidate. Its effect is to seal finally, in balanced formation, the four Pillars in the Sphere of Sensation of the Candidate. This does not imply that they were not naturally there before, but, in the natural human being, the symbols are unbalanced in strength—some weaker and some stronger. The effect of the ceremony is to strengthen the weak, purify the strong, and so begin to equilibrate them, and at the same time make a link between them and the corresponding forces of the Macrocosm.

The Effect of the Ceremony on the Sphere of Sensation

Previously, we have briefly touched upon the subject when dealing with the removal of the implements from the Altar and the Admission of the Candidate. The four Pillars thus referred to must at this point be distinguished from the Middle Pillar of the Candidate—which relates to the subtle body centers in the front of the body (which, for the purposes of a simple explanation, could be described as groups of minor chakras which have been grouped Kaballistically), not to be confused with the major

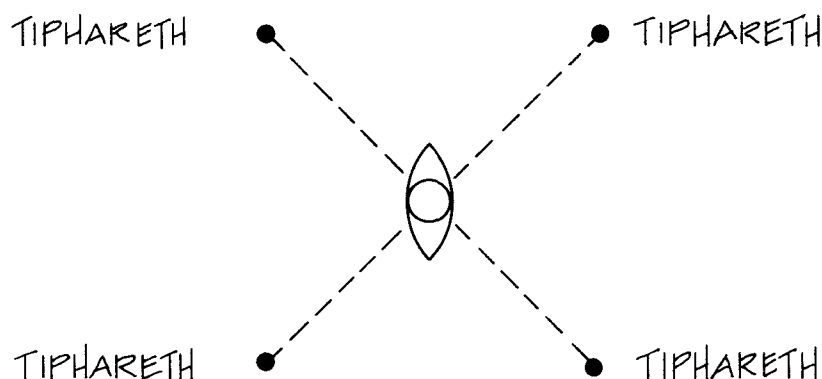

*Figure 64
The Four Tiphareth Points*

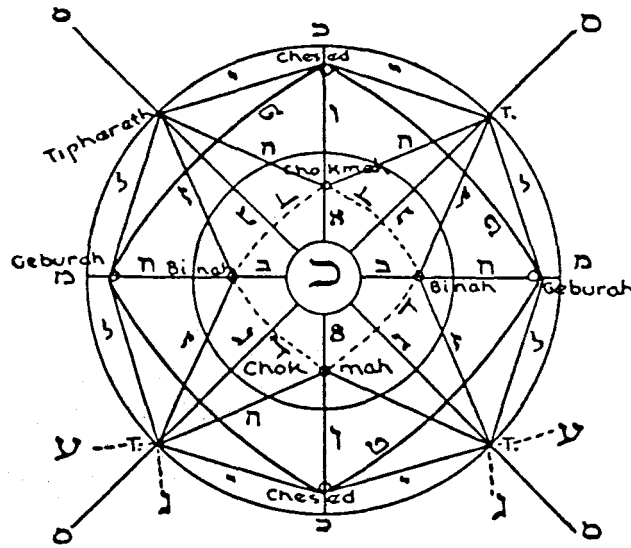

Figure 65
The Tree of Life in the Sphere of Sensation

chakras which are along the spine. The four Pillars represent the Aura of the Candidate. Taylor always taught us that this is what is most affected (the exception is the throat chakra at the back of the neck, which is touched directly by the sword of the Hierophant during the Obligation).

The Golden Dawn, according to Taylor, in its "word of mouth" teachings, considered that the body had seven basic auras and that each grade stimulated an aura. The Neophyte grade affects mainly the physical aura, which is also called the etheric double. It also must be remembered, though, that various parts of the soul which are considered distinct from the auras are also affected.

The Hierophant then commands the removal of the rope, which hitherto has been purposely retained. Symbolically, the rope restrains the actions of the natural human, whose temptations are toward the Evil Persona.

The four Pillars being thus firmly established, the Candidate is

invested with the badge of the White Triangle of the Three Supernals formulating in Darkness. The Higher Self is enabled in reality to also consent. The free will of the natural human is never obsessed, either by the Higher Soul or by the ceremony, but, the will consenting, the whole of the ceremony is directed toward strengthening its actions. As the badge is placed upon him, it is as if the two Great Goddesses, Isis and Nephthys, stretch forth their wings over Osiris to restore him to life again.

The badge referred to is not a physical badge, but a symbolically placed symbol in the aura of the Candidate, on his forehead.

*The Final Circumambulation
in the Path of Light*

The Mystic Circumambulation follows in the Path of Light to represent the rising Light in the Candidate, through the operation of self-sacrifice. As he passes the Hierophant's throne, the red Calvary Cross is astrally formed above the astral white triangle on his forehead, so that, so long as he belongs to the Order, he may bear the potent and sublime symbol as a link with his Higher Self and as an aid in searching out the forces of the Divine Light—if he will.

The Replacement of the Implements on the Altar

The manner of replacing these is the opposite to the figures above, which show how they were taken off the Altar. These represent the component parts of the Candidate, which have now been purified, and his Sphere of Sensation, which has now been equilibrated.

The Address to the Candidate

The Higher Soul or Genius now returns to the Invisible Station of Harpocrates, the place of the Hidden Center, while continuing to retain the link formed with the Candidate. The Address of the Hierophant is intended simply to effect the distinct formulation of the symbols of the 0=0 Grade of Neophyte in the Candidate, and it is therefore only when this is finished that the Watcher Anubis announces that the Candidate has been duly admitted as the initiated Neophyte. The Hieres is charged with a warning

address, as again confirming the will of the Candidate and addressing the final menace to the Evil Persona. The Hierophant states clearly that the symbols must be equilibrated in the Sphere of Sensation before a link can be formulated between them and the forces of the macrocosm. The necessity of examination is insisted upon so that this may be completely done.

Mixing of the Fluids

The Kerux pours out the two fluids to make the semblance of blood. This is to fix in the Candidate's sphere the symbols of the forces of transmutation in nature, and also to make an astral link between these and the Candidate's physical life, as a guard of the secrecy of the Mysteries. This particular form of transmutation is used as showing the effect of a mixture of forcing in producing a third appearance totally different from them. The red color is symbolic of the blood of the Candidate.

In the ancient Mysteries, the Candidate's blood was actually drawn at this time and preserved as an avenging link in case of his proving unworthy (consider the modern theory of Radionics and its effect on a blood sample). Transmutation effects matter quite well, seeing that the astral link is formally established.

The final speech of the Hierophant is further intended, beside its apparent meaning, to affirm that a person only partially initiated is neither fitted to teach nor to instruct even the outer and more ignorant in Sublime Knowledge. He is certain, through misunderstanding the principles, to formulate error instead of truth.

Closing of the Neophyte Grade

With the knock of the Hierophant, the generating current he created to keep the Light through the Portal starts to close. The cry of "Hekas, Hekas, Este Bebeloi" announces to all forces present in the Portal to leave. The four knocks of the officers then withdraw the Light, which then withdraws through the Hierophant—the second stage of the withdrawal. At this point, the Kerux must be ever watchful for any elemental force created during the ceremony, which might linger. There have been a

number of instances in the past where there has been this type of residue left, which, if noticed, should be immediately banished by the Hieres with the sword. The purification ceremony makes doubly sure that no negative side effects remain within the Hall.

Reverse Circumambulation

The reverse Circumambulation is intended to formulate the withdrawal of the Light of the Supernal Triad from the Altar so that it may not be profaned by abiding without due guard. Not that the Divine Light would suffer thereby, but because it might initiate an Avenging Current if profaned. This is what is implied by the Law of Moses in the prohibition about offering unconsecrated Fire either before or within the Veil of the Tabernacle. As a vibratory formula, the reverse Circumambulation represents the reversal of the current and the restoration of the operator to the ordinary condition. The mystic reverse Circumambulation forms its procession in the South, beginning from the Station of Dadouchos, as symbolic of the Ending Judgment of the World by Fire.

Partaking of the Eucharist

The Mystic Repast is communion in the body of Osiris. Its Mystic Name is "The Formula of the Justified One." The important point to remember is that, through the process of the ceremony, both the Paten and the Wine and Salt are magically transmuted through the magnetic influence of the ritual itself. This is done through the Osirian concept which is directed by the Hierophant. The Kerux, in finishing, inverts the Cup, as the Watcher of the God, to show that the symbols of self-sacrifice and of regeneration are accomplished. The proclamation is confirmed by the Hierophant, and the chief officers give three strokes, emblematic of the Mystic Triad, and repeat the Mystic Words. The Hierophant, in his final speech, seals the link, first formulated between the members of the Supernal Triad for each one present, that it may prove to him or her a guide for the ultimate attainment of the supreme initiation—if he will.

From Whare Ra Temple

Lecture on 0=0 Grade*

As I told you before, the 0=0 ceremony is one of the most important of our Order. You will see, I think, the reason for that in a moment, if you consider what it is that we are associated for. For we are here, a group drawn together from all conditions. If you take the whole Order, including the English, French, and Eastern Temples, it is still more noticeably the case. People of every grade of society, of every grade of opinion upon politics, religion, upon all subjects whereon people differ most, people who, if they were not members of this Order, would probably be flying at each other's throats, meet in perfect harmony and absolute trust, because they are all in search of the same thing. They approach it, however, from all sorts of different points. Men of science hope to find the realities which lie behind their subtlest investigations. Politicians, men and women who are anxious in some way or other to benefit humanity, hope that they will learn the secrets and reasons of some of the misfortunes which beset humanity, and how these misfortunes may be lifted. Physicians, hope that they may find the key to some of the deepest mysteries of human life, and human suffering, diseases, and death. And so,

*I am unaware of who wrote this lecture, but it was probably Mrs. R. W. Felkin.

from every point of view, men and women are drawn into the Order, in the hope that they may find the key to some of the mysteries which puzzle them most. And every one of them finds something which is to a certain degree repugnant. Some who come to us are trained with a contempt, it may be, or a distant distrust at any rate, for all ceremony, symbol, and ritual observance. Others come with a great liking for these things. Others, again, come with a great distaste for the learning of symbols, Hebrew letters, and the apparently meaningless objects of Archaic study. Some come with a great delight in all Archaic and mystic study. But within this Order all are treated exactly alike and in the same manner. If he or she wishes to progress, he or she must attend the ceremonies, must understand the ceremonies, the ritual, the symbology. All must learn the lectures and the archaic knowledge. All must go through the discipline, because that very point which to each is repugnant shows the point where he or she is out of key with the Brotherhood; shows an angle which must necessarily be rubbed off before he or she can be at all fitted for the building of the Temple.

Now, the ceremonies you are, as it were, shown and put through in actual physical practice and in the visible form are the Path, and the ceremonies which you will have to go through mentally, psychically, and spiritually in your future training and in your future occult life. And therefore the most important is the first entry into it.

The ritual of the 0=0 is, as I have said, full of symbology, and the symbology is that of the first emergence of the soul and the consciousness from the material, and its entry into the widest spiritual perception. It is somewhat in this way: as though a teacher beginning to train a class upon a vast subject should, partly by showing them a diagram upon a blackboard, it may be, or on a sheet of paper, of the whole course of study that they were to pass through, mapping out the line for them. Now this, in such a subject as ours, cannot wholly be done by diagram. There is so much of change, of growth, of progress, that has to be indicated, that it would take an infinite number of diagrams on paper to

indicate what we can show by our ritual and ceremony within an hour. And every point in that ritual and ceremony has its correspondence in the future mental development of the Neophyte. And therefore every point should be carefully considered, since by it the Neophyte may know whether he or she is on the right line or not in his or her future progress. It would be impossible for me to tell you now the whole of the symbology and the mysteries contained in the ceremony of the 0=0 grade; because, even when you get into the Second Order, and when you attain to the rank of Minor Adeptship even, you have to wait for a considerable time before the full mysteries of the 0=0 ceremony and its full symbology are explained to you. Even if I were allowed to expound it more fully now, the words would be to all of you idle echoes. They would convey no meaning. But a certain amount I can tell you and a certain amount you can understand, and that amount will be quite enough to give you a great deal to think about.

Consider then, when you first enter the Temple in the 0=0 grade. You are, as a Neophyte, blindfolded, but after the hoodwinks are removed, you see. Now consider, what is the arrangement of the Temple when you come into it? The first thing that will strike you is the Altar in the center. That Altar signifies the Universe. The first thing that you have to learn is—that upon first entering occultism your minds must realize that there is a great deal beyond the material universe. By the material universe, I mean the entire universe, not only as far as the eye can reach, to the farthest star, but as far as you can conceive. The whole of that is symbolized by the cubical Altar, the double cube, which stands in the center of the room. Such must be the place that the material universe must occupy in your thoughts as you are thinking upon the subject of occultism. Hitherto it has bulked supreme in your minds, probably. Why a double cube, I shall come to later. But you know that the universe is subject to fixed laws. As far as ever you can trace by science or by induction, the universe is subject to fixed laws, some of which you can formulate, and from that formulation you can deduce others, showing that in all your science and all your undertak-

ings you postulate fixed laws. Now these fixed laws are outside and beyond the universe, therefore upon the universe as operated on by fixed laws do you fix your thoughts. Now you see upon either side of the Altar two seats, occupied by Stolistes in the North and Dadouchos in the South, Stolistes bearing the Cup and Dadouchos the Censer. These are the powers of Water and Fire, the powers of cold and heat, the receptive and the energizing, the negative and the positive, the female and the male. And between them lies the universe. That is the first lesson that you have to learn.

Then you see at the East the throne of the Hierophant, and at the West the throne of the Hiereus. The Hiereus is in a black robe and bearing a sword. The Hierophant is in a red robe and bearing a crown-headed scepter. This symbolizes the powers of Light and Darkness. Again we see the conception of the positive and energizing and the negative or receptive. Darkness absorbs all things. Light manifests and reveals all things. Between the darkness and the light vibrates the Veil of Colors of the Earth. These again are operating upon the cubical Altar, and so you have, as it were, four strenuous streams of force directed upon the universe; and that is the first thought that must occupy the mind of the student just emerging from the outside world, from the condition of material darkness, into the study of occultism. Not only that; from his study of the universe he finds certain laws prevailing,' and therefore assumes that these laws operate more and more widely still, reasoning from the smaller to the greater. He must take, as it were, the Sight of the Eye of GOD, and see the universe as a small speck operated upon by the four powers, who present themselves to the thought of the student as four Angels, or as four Gods according to the earlier system. The Angels of the Egyptian, Gnostic, and Christian systems are all personifications of the Four Forces operating upon the universe, which you see personified by the principle officers in the Hall of the Neophyte—Raphael, Gabriel, Michael, Auriel. Then, just beyond

¹Throughout this chapter, the masculine pronoun is used in its generic sense to indicate either sex.

the Altar, you see two Pillars. These two Pillars represent the same idea in another form; they are the Pillars of Light and of Darkness, the Pillars of Fire and of Cloud of the Israelites wandering in the wilderness. They are the Pillars of Jachin and Boaz of the Temple of Solomon. And between them is another chief officer, the Hegemon, with the white robe and the miter-headed scepter; the white robe also signifying the synthesis of all color. I told you that between the blinding Light and the absolute Darkness vibrates the Veil of Color, and the synthesis, the combination, of all colors is white. The robe of the Hierophant is flame red because the blinding light which issues from the radiant East is that which no eye of man can gaze upon unharmed, and therefore a symbolic color is chosen. Now, fixing the attention for a moment upon the Hegemon, you see that the Hegemon represents the synthesis and the equilibrium of all the forces that act upon the universe. Therefore the Hegemon sits between the two Pillars, representing the perfect equilibrium; between them is the universe. And carrying the thought beyond the universe to the point of equilibrium you see the two Pillars forming as it were a gateway. Between them the Hegemon who is to receive the student of occultism. Such then must be the mental pose of the student, once the student sees the diagram, once the student is taken through it at his initiation. And the intention is that ever afterwards that ceremony and the plan of the whole shall dwell upon his mind and be always present to his mind, in order that he may attain the proper pose of mind to pass on to learn the secret of the universe. At the very opening of the next grade, passing from 0=0 of Neophyte to the 1=10, the first words the Neophyte hears are: "Prepare to enter the immeasurable regions." Now remember, the cubical Altar is the measurable. You desire to learn the secret and the meanings of the forces that operate upon the universe, therefore you must first enter the immeasurable regions. You will never learn them as long as you are within bounds and measures. But mentally elevate the thought above and beyond the region which is measurable, and you will begin to see the forces which form infinity act upon the finite universe. Now, let's go a little more into particulars. This

Altar is a double cube; i.e., it has ten squares which are visible if you walk around it and examine it all over. But, if you are standing upon the Earth and looking at the universe, as a man of science stands upon the Earth and contemplates the universe, as the materialist of any sort contemplates the universe, the cubical Altar is, as it were, raised immediately above the head, so that he can only see the bottom square upon which it stands. Hidden from him by the bottom square are nine other squares. Now the bottom square of the cubical Altar represents all that possibly can be learned by logic and deduction, or by the five senses, by any scientific instrument, by any scientific discovery. A minute and perfect acquaintance with the bottom square of the cubical Altar is the whole that can be gained. Therefore the Neophyte has first of all to learn to put things in their proper place. In this Order no scientific attainment and no scientific discovery is despised or undervalued. On the contrary, it is most highly valued and most highly esteemed. The Neophyte, however, desiring to enter the path of Occult Science, has to remember that the whole of the universe is represented by the cubical Altar in the center, and that the whole of scientific investigation is represented by one tenth of that cubical Altar. And note also that the Altar stands upon its bottom square. The bottom square is therefore out of sight in the ceremonies of the Order. Why? Not because we undervalue the bottom square. On the contrary, we recognize that it is the foundation. It is the basis upon which our Altar stands. But in the studies and in the ceremonies of this Order, it is other things which we investigate and consider. Our Altar must have its basis and we must stand firm upon that basis. This is the position, not only of science, but of everything that can be attained by discovery, by the five senses of the logical brain.

Now, the same ideas are resumed in the implements and the ornaments that lie upon the Altar. At the East end of the Altar there lie one or two roses. At the North end is the Paten with bread and salt. At the South end is the Lamp of Fire. At the West end is the Cup. There is also the Colored Cross and the White Triangle.

According to our teaching, and according to the idea which I want every student to grasp, and to hold in his hand, these resume the ideas, showing how the forces, operating from the four Angels from outside the universe, are reflected in the universe itself. And therefore we can trace the operations of these Angels who are outside of the phenomena which we can observe in the material universe. Now, when the Neophyte is brought into the Hall, all these things are arranged round him, but he sees them not. He is brought in blindfolded and with a rope round his waist, and this is also the mental condition in which the Neophyte must continue his occult study. He must not imagine that he will mentally see what it all means. Not until he has been inside for some time, will he see. Immediately he begins the Path of Occult Study he will be aware of things of which he knows the meaning, certain strange thoughts, strange ideas, and strange questionings as to whether there may not be something or other discoverable behind the veil of matter, which hitherto he has regarded as impenetrable, but they will be but vague voices, vague sounds, vague hints, just as when he comes blindfolded into the Temple he hears vague sounds, vague voices, perhaps some of them familiar voices, some of them not, moving of feet, and so on. He is led on a path he knows not. But why does he go forward? Because he has a certain amount of faith. Because he believes that somehow or another something will be shown to him bye and bye, and that the hoodwink will be taken from his eyes. Now he must learn that in order not to be impatient, because at the beginning of occult study he is unable to see what it all means, or unable to see what any of it means, whither it is tending. Mentally he is hoodwinked, mentally he is bound by the finite conditions out of which he has just emerged. And therefore, his mental pose must be to not be impatient with the blindfolding and with the rope and with the conditions of finite limitations which he is still under, but to believe that he is under the charge of someone who knows, and bye and bye those limitations will be removed. Now in the full Temple ceremony there is a Sentinel outside the door armed with a sword. Practically in most of our ceremonies the Sentinel is dispensed with, but the Sentinel

nevertheless has an important symbology. Because, you will notice, one of the chief officers goes outside the Temple to bring in the Neophyte. Such an officer is known to the Sentinel, and the Sentinel allows the Neophyte, blindfolded, to pass in, in company of the initiate who is known to him. Otherwise the Sentinel is armed with a lethal weapon to strike any intruder who is rash enough to attempt to enter the Portals. Now that is an absolutely true symbology of those who attempt, themselves, without initiation, to force a way into the Occult Mysteries. It is a well-known fact, which I think every physician will testify to, that all who have tried to do so have either failed miserably, being driven back by the Sentinel, or have paid the penalty in the madhouse or in the grave. The initiation comes from within. The message is sent from within to bring the Neophyte into the Temple where he may be taught. The Sentinel's weapon is lowered and he is allowed to pass. Translating that into the material language of everyday life, everyone knows the miserable end to which would-be mediums or students of spiritualist phenomena come usually, if they attain any amount of psychic development without proper training. Whereas, in our Order, everyone has before him the example of others who have trodden the same path, and who are to testify, not only with their voices, but to show by example that the path is safe. But for all of you, as it happens, I stand the most advanced among you, as the only one who has passed into the Second Order, and I can assure you therefore both by my word and by my example that the path is absolutely safe both to brain and body. And to me where I stand there are others far in advance of me who are able to give me the same assurance of the perfect safety of the path, and who are able to instruct me, as I am able to instruct you, on every step of the road. So the Neophyte is brought past the Sentinel, whose weapon is so deadly to those who strive to force their way in.

Then within the doors stands the Kerux, carrying the wand and the lamp. Immediately the student enters mentally the Path of Occult Wisdom, there is a lamp which always goes before him. But at first he sees it not, at first he appears to himself to be wandering in darkness. I want really to emphasize this point

strongly, because it is the experience of every student who enters the Path of Occult Knowledge. In the first steps he appears to be wandering in darkness, and he appears to be going he knows not whither and by a devious road and without a guide. It is for that reason he is led in various circumambulations which all have their meaning, but whose meaning is carefully concealed from the Neophyte. His mental attitude is precisely the same, and must remain the same for some time to come. Now the Kerux leads him on the path round and about the Temple, but observe, not to the point of equilibrium for a long time. First of all he has to show his earnestness by pledging himself to the duties of the Order he is about to join, and to the diligent prosecution of Occult Science, to secrecy and to the Brotherhood. And this pledge is an absolute translation into words of the mental character he has to cultivate. Observe therefore that your mental pose must be that which you take up as a Neophyte in the Hall of the Neophytes in the Temple. The Neophyte is helped at various points by various officers. For example, the Hieres threatens him with the Sword of Darkness, and the Hierophant menaces him with the Scepter of Light. He has to know both extremes before he can know the equilibrium, again an absolute picture of the mental state. This state must vibrate, it must touch the extreme of darkness and it must face the blinding light, but being able to bear neither, it finds that there is no rest in either before it can reach the point of equilibrium. And moreover he must undergo the purification by fire and the purification by water, he must be consecrated by the Stolistes and the Dadouchos. He must, that is, be purged of the influence both of the negative and of the positive, that the limitations and the evil beginnings to those two qualities may be rooted from his mind, and that his mind may attain an absolute equipoise. Thrice must this mystic consecration be repeated, and at last he may be deemed to be purified from the limitations and the evils relating to those two qualities of water and fire. Then at last he is brought up between the Mystical Pillar, into the symbolic gateway of Occult Science. Then the Hierophant advances from his throne to meet him and draws him between the Pillars, thus acknowledging that he has attained the

equilibrium. Now that is the condition of mind that the student has first to attain to, coming in from wandering in darkness, by his faith, passing round under the influence of all the four Angels who operate upon the universe and whose operations produce all the phenomena we know and see. At last faith changes to sight. He is brought up to and attains equilibrium of mind. That is only the first step, and it is a step which will probably take the student a long time to attain. Therefore let the student examine his own mental state and mental pose from time to time, and try to see whereabouts he is mentally in the Initiation Ceremony.

The Lamp of the Kerux will always go before him. Let him then understand that the Light is before him though he sees it not. He will see it by and by, and therefore let him understand that the mind, being set right, and earnestly desiring truth, and earnestly desiring absolute goodness, it is impossible for him to go wrong. Any step he takes is guided, though he knows it not. And if it be any help or any consolation to those who still find it difficult to realize this, I may say of my own knowledge that a time arrives when, a certain advancement having been made, it is possible to see. To every one of you this is possible. Only advance far enough and the hoodwink will be removed off your eyes, and you will actually see and know the Divine Guidance of the Kerux of the universe guiding the step of every Neophyte. The Neophyte is hoodwinked and knows it not, but you will know it and you will see it, though you may not at the moment be able to tell him. Those of us who have advanced far enough can say of our own knowledge that for every student who is really striving in earnest for the Occult Science it is really absolute fact that the Lamp of the Kerux goes before him and not one single wrong step can be taken. Then you notice that as you go on to different ceremonies of the Order that these Pillars are in different parts of the Hall, signifying for you your progress in the Order. The gateway of Occult Science is behind you in some senses, before you in others. It is in one direction or another direction according to your progress. Standing firm upon its fourfold basis is the black square, symbolic of the materiality upon which we all stand, but bearing upon its summit the triangle symbolic of water and the

triangle symbolic of fire. The two triangles and the lamp signifying the Divine Essence on the summit. Observe now there is the seat of the Stolites, there is the triangle of fire, there is the platter of salt signifying the Earth. You are therefore not to conclude that all materiality comes from one direction, or all the spirituality from one direction. In every direction in the Hall you will find, if you study the symbols, that all the elements are united, but some are more prominent according as you fix your attention on one point or another. The position of the Great Angels ruling the universe does not cause them to throw their influence solely and immediately upon that point of the universe that is opposite to their feet, for that would produce discord and want of equilibrium at once; and the influence of the elements again are counterchanged and not even in such regularity and absolute symmetry as could be explained now, but according to a very complex method of counterchanging, the effect of which is to produce that equilibrium which is the keynote of the teaching of the grade.

Now further you are to understand that the signs of the grade are to be very carefully given. The signs of the grade are not conventional forms, not merely signs of groping, although that is their first meaning. This is the sign also of the giving out of force. It is the sign of entering the Portal, and further a sign of humility, and the bowing of the head to a greater light and a greater power. To give the signs properly, you should always remember to give the step of the left foot, which should be given firmly, and the hands should be raised above the head and lowered to the level of the eyes and the hands should be pointed straight. The vital force emanates from the eyes and the hands, and these should be all in the same line, with the foot firmly planted on the ground. That sign is not merely a sign of groping or of respect in passing the throne of the Hierophant, but it is an occult sign of great power whose meaning you will learn hereafter when you enter upon the study of practical magic.

Now, one thing more with regard to this grade. You are to remember that the Hall of the Neophyte, and in fact the whole Temple of the Order of the S. . M. . represents as it were the

porch of the Temple. When your feet are well planted in the porch, you are well on your way to entering the Temple. You must therefore look upon it as though, at this end of the Temple, and behind the throne of the Hierophant, there was a veil extended separating the Outer from the Inner, and that through the veil, as a priest emerging from the Temple, comes the Hierophant to instruct, to initiate, to perform ceremonies which are really of magical import. So, in the same way, you should not look upon any other Adepts who are present. You in the Order can know nothing about these or their grade, you merely know that they are members of the Second Order and that they have attained the grade of 5=6. They may be Minor, Major, or still higher, but, passed within the veil, they are lost to your sight. They come forth in the Temple ceremonies as veiled figures whose advancement in the Outer you can know nothing of. That is the way mentally in which you should look at your own mental future. Now when you have passed through the 0=0 grade, you have a certain lecture, the first knowledge lecture, to study, and no doubt all of you who have had that first knowledge lecture will consider it rather a heterogeneous mass of archaic knowledge of various kinds, none of which matters much, and most of which you were familiar with before. But there is really a good deal more in it than this. Of course anyone who has studied mystic subjects at all is probably familiar with such things as the symbols of the signs of the Zodiac, the Planets, and the Hebrew letters. But these symbols are not chosen by chance, but because they are absolutely necessary to further advance. And I may mention here that it is especially desired by the Greatly Honored Chiefs who guide us in the Second Order that all students should be most exactly particular in the drawing of the symbols and in the form of the Hebrew letters. Of course there is a current Hebrew which some of us may write and which is often badly written. That has nothing more to do with it than writing an English word. But everyone should know the exact form of each symbol and each letter, and be able on occasion to draw them clearly, beautifully, and with mathematical accuracy, because these symbols are not merely conventional symbols. Every one

has a meaning. If you will take for instance the symbol of Fire (\triangle) and the symbol of Water (∇), these are as I have told you the symbols of the Great Gods, and particularly appropriate symbols because the aspiring of the Fire always tending upwards is well shown by the triangle pointed upwards, while the instability, but perfectly horizontal surface, of Water is well shown by the triangle pointed down. And the bar across (\triangle) and the bar across (∇) give us the Hexagram, the equilibrium of the elements, the atonement, and therefore give you these elements as they are in the universe. Hence Earth and Air are the more material and physical representations of the same forces as Fire and Water. And that is the meaning of the bar across which converts Water into Earth and Fire into Air. Then take the ordinary symbol of Aries (Υ); perhaps you will say it is a very ordinary symbol of a goat's head and horns. So it is. Now what was the symbology of "animal" according to the Egyptian and according to the Qabbalistic schemes? "Animal" signified the lower part of man's nature which was to be sacrificed. What then does the ram signify? Sensuality by all the schemes. Now this signifies also the Pentagram, but the evil Pentagram, the Goat of Mendes. How then should the Ram or Lamb be the divine symbol? The symbol of the Vernal Equinox? The symbol of the Dawning Light? Because the ram must be slain, the ram's head inverted; the evil passions subdued and sacrificed, the sensuality cast out. The lamb which was slain, the symbol of the dawning light of the universe, the symbol of the Golden Dawn. As you see, there is a great deal in that symbol of Aries (Υ) read properly. And so again the symbol of Taurus (♉) the bull; the symbol of Earth unites for us the two great lights: the greater light that rules the day and the lesser light that rules the night. These symbolize for us the light and the darkness, yet both illuminated by the divine rays, and therefore the equilibrium, which is the key of progress upon the Earth plane. And so we might go through every symbol of the signs of the Zodiac if there were time. We might deduce a great many lessons from them, but the one lesson that I want to emphasize now is that above all, the symbols must be accurately learned.

I think I told many of you before now that the planetary symbols are formed from the circle, the crescent, and the cross; the cross signifying corrosion, the circle signifying the red, and the crescent the white metals, giving you thus the metals of every planet, and giving you, when you get far enough to understand it, the meaning and influence of every planet. Giving you also, when you get further on still, a key to color, a key to the symbology of that veil of color which vibrates between the light and the darkness. It is not for nothing that the iron, whose color is greenish, in its corrosion becomes red, and that copper whose color is red in its corrosion becomes green. All these have a symbology. Every planet has its color; every sign of the Zodiac has its color; every element has its color. Every symbol in the world has its appropriate color, and every color in the world has its meaning. And the meanings rightly interpreted give the key to much of the physical and material science which is absolutely dark at present because the meaning and the color are not known.

Now, the grouping of the planets, and of the signs of the Zodiac, according to their triplicities, and according to the signs they govern, is extremely important because it gives one the key to the influences which are most strongly directed upon this part of the universe from those Four Great Angels from whom we have seen those forces operating upon the material universe, where they are concentrated and summed up. The ring of the Zodiac is around the world, and the world turns round and presents a different face to each sign in turn. And from the different directions of that wheel are various forces constantly flowing in upon the world. Not in exact equilibrium, for exact equilibrium for the world would mean the cessation of life. The present material and finite life of the world depends upon a certain want of equilibrium. The progress of the student out of the finite into the Infinite Knowledge depends upon his knowledge of the forces flowing in upon the world, which indeed are all equal and in exact harmony, but which, not all falling at the same precise moment of time, are slightly out of equilibrium at each particular point, and therefore by that slight want of equilibrium producing slight

transient change. Therefore the influence and connection of elements, planets, and signs is to be so carefully studied that it becomes absolutely a component part of oneself, and then when the correspondences are learned further on the mental, psychical, and spiritual, results will be immediately perceived. Now, finally in the first knowledge lecture you get the study of the Hebrew alphabet, and the formation of the Hebrew letters is most essential. I can only give you a very slight idea of one or two small points indicating where the great importance comes in. If you take the Hebrew alphabet to be formed from the *Yod* (י), that is the first beginnings, the first thought of the alphabet. And if you look at it I think that it will remind you above all of a tongue of flame curling up from a fire, an escaped tongue of fire not burning centrally as a lamp or candle, but flying off without any material to feed *its* flame. There are many other symbolisms connected with this *Yod*, *many* much deeper, but that will do for the present because it will give you the root idea of the *Yod* in easy, simple form. Now, the *Yod* (י) brought down to Earth plane (the *Yod* lies above the line in writing) as a fire burning upon the Earth, or a fire influencing the Earth, becomes the letter *Vau* (ו). Here then we have two letters of the Great Fourfold Name of God

(יהוה) and two of them indicate the Fire. Now we pass from *Yod* to the first letter of the Hebrew alphabet, *Aleph* (א). This consists of three *Yods*—an elongated one very much like *Vau* between two others, and there you have the Three in One: the Three Fire Spirits, the Three Energizing Spirits from whom proceeded all things; i.e., the Great Unity.

Now the next letter, *Beth* (ב), is the Binary, the Two. If I put a *Beth* beside an archaic ? , you will see that they are very near each other in shape, so near that it is tolerably certain that one was drawn from the other. The Binary is the great point which we have been considering so far, the two forces, the positive and the negative, the Severity and the Mercy which are united in the equilibrium. Therefore AB or ABBA represents the Father. Another symbology in the Binary is that it is almost identically the figure of a swan sailing over the water, the swan being symbolic of the elements of Air and Water, as the *Aleph* (א) is

symbolic of the three *Yods* of Fire, Air, and Water, therefore the elements that are the cause of Earth are the three that are synthesized in Earth. Also, *Beth* (ב) is a house, and is the representation of a lean-to shed against a wall on a section. I give you this to show that the forms of the Hebrew letters are of very great importance. Then *Gimel* ג is the third letter, the letter of production or emergence. A plane, an emergence or passing through, that was the glyph of Horus, a glyph of birth also. Now in the Qabbalistic scheme there was no feminine represented among the causes of the universe. The first great Causa Causans was the Father-Mother, but Isis was Nature. Osiris was male-female, therefore the Spirit, which according to some schemes was not as mystic as the Hebrew, was feminine, is represented masculine by the addition of the *Yod*. Now therefore you have the first glyph of the:

Aleph א Three in One

Beth ב Two, the House

Gimel ג Emergence, the Birth

And the three together representing the origin of the alphabet, the origin of the Word, the origin of things.

The *Daleth*, the square (ד) or this wise, ⊥, the Mason's Square. Or you may put a cross in a diamond-shaped square (⋄) then you need only one line to represent a square. You have your cross which signifies the world and an indication of the quaternary or square beyond it ()+). So the ד and the 4 are the same symbol.

I do not propose to go any further with the Hebrew alphabet. I just indicated that to show you the enormous importance of being absolutely accurate with the forms. And remember, above all things when making your Hebrew letters to make them square. Avoid all cursiveness, that is, in writing anything for inscription or mystic working of any kind. You will not yet be able to use the Hebrew letters for magical ceremonies or anything of that kind, but hereafter you will, and you will find that, if you have got a careless style in writing Hebrew, and you do not fully understand the exact shape of every letter (and I talk as one who has tried and knows), that you will fail in your ceremony and you will fail

absolutely as if you made a chemical combination with false weights or as if you had painted a picture with dirty muddy colors. Absolute accuracy is the only road to success. Every letter must be drawn with as perfect form and perfect intention as if you were making a mathematical working drawing for an engineer to make a machine from. Get out of your head the notion that you are writing a current language when you are making mystic words and symbols.

 Llewellyn's Golden Dawn Series

Z-5

Secret Teachings of the Golden Dawn



Book 2
The Zelator Ritual
1 = 10

Pat Zalewski

LLEWELLYN'S GOLDEN DAWN SERIES

Z-5

*Secret Teachings of the
Golden Dawn*

*Book, I
The Zelator Ritual*

1=10

b y

Pat Zalewski

1 9 9 1

Llewellyn Publications
St. Paul, Minnesota 55164-0383, U.S.A.

Contents

<i>Foreword, by Frater K.◉.M.◉.T.◉</i>	<i>xi</i>
<i>Introduction</i>	<i>xiii</i>
Part 1—The Ritual	1
Ceremony of the 1=10 Grade of Zelator	9
Part 2—The Commentary	25
The 1=10 Earth Grade of Zelator	27
Symbolism of the Opening	67
Part 3—Where Ra Lectures and Addresses	91
Lecture on the 1=10 Ceremony for the Zelator Grade	93
B Lectures and Addresses of the 1=10 Grade of Zelator	109
1. The 1=10 Ceremony	111
2. The Rituals and How to Read Them	115
3. Thinking Backwards	117
4. The Hebrew Alphabet, by M. C. (Mrs. R. W. Felkin)	119
The Second Knowledge Lecture	129
Evil, by A.M.M. (R. W. Felkin)	133
Symbology of the Gate, by M. C. (Mrs. R. W. Felkin)	137
B2: Lectures and Addresses for the 1=10 Grade	139
1. Ancient Egyptian Religion, by M. C. (Mrs. R. W. Felkin)	141
2. Reading of the Scriptures, by M. C. (Mrs. R. W. Felkin)	147
3. The Twelve Tribes and Astrology, by MacGregor Mathers	157
Daily Rhythm for the 1=10	167
The Elementals of the Earth Grade: The Gnomes	169
Part 4—The Ritual According to A. E. Waite	173
The Ceremony of Advancement in the 1-10 Grade of Zelator (A. E. Waite's version)	175
<i>Bibliography</i>	209

Foreword

This book continues an elucidation of the Golden Dawn system of magic that began with the Zalewskis' previous book on the Neophyte grade (Z-5. Book 1). At this stage the student begins to investigate the four elements (earth, air, water, and fire) beginning with earth. It is the task of the student during this phase of the knowledge search to established the qualities of earth in the worlds of the Kabbalah: What is earth on the material plane? My body is earth—what does that feel like . . . what does that mean to me? How does emotion exhibit the qualities of earth? How does wind erode mountains? What's the similarity? The basin of the ocean is earth; what part of myself contains, restrains and forms the shape and movement of my thoughts? Without a base upon which to lay fuel a fire will burn but fitfully, in what ways do I ground my inspiration in concrete activity?

The objective of the Zelator ceremony is the ritual placement of the earth element into the aura of consciousness of the aspirant. In the ensuing months the student must then become acquainted with the element: learning to identify this element

no matter where or how it appears in their subsequent working. The explanatory supplement facilitates the student's exploratory work of the ritual in that it serves to establish associations in the student's mind. It will also inform them of the process whereby these symbol associations may be brought to life within the student.

It is vitally important that the student "do" the independent rituals (ritual of pentagrams, Rose Cross, Invocation, etc.). It is vitally important that the student "do," beyond a shadow of a doubt, the work of establishing the earth and subsequent elements in their consciousness. It is vitally important that the student work at establishing and maintaining a relationship with a peer or lover. They are no different—relationships are initiated, developed and maintained only by careful attention and response to the needs expressed by the partners in the relationship. And again, like any other relationship, expression of needs facilitates response by the other partner whether physical or non-physical. The Zelator, then, must ask her/himself what does earth need from them (physically, emotionally, mentally, spiritually). If the student has reasonable command of imagination they may visualize Gnomes and engage in conversation regarding these needs (being ever wary of getting one's own "stuff" in the *way*; *i.e.*, hearing what you want to hear). The student will be able to engage in meaningful dialogue with the elemental as a result of this interchange based in equality.

Changing oneself is no piece of cake, the answers to these questions may be difficult to accept and integrate into the personality of the student magician but through diligence and persistence change will occur. Yes, the prime ingredient to ritual is to do it. The prime ingredient to instituting change in the magician is to work at it—to do it.

**—Fra. K' . M'. T'.
Hermetic Society of the Golden Dawn**

Introduction

This book is the second in the series of Golden Dawn ritual analyses and is the first on the elemental grades. Very little if anything has been done on the elemental ceremonies in the past, because their function has, for the most part, been obscure. Most Golden Dawn students seem to consider that exposure to the elemental Tablets is the main pinnacle of these ceremonies, and some have even substituted the "Opening by Watchtower" for these grades.

The operative word, throughout both the Outer and Inner Order of the Golden Dawn, was "fusion," where all the main *systems* were brought together for combined usage. While it *is* true that the Elemental Tablets (or Watchtowers, as they are sometimes called) *were* the pinnacle, and related various subsystems together, it is equally true that these tablets were an impetus or force *behind* the system and were never envisaged for direct use in the Outer Order. To truly understand the function of the elemental grades, you must go through the ceremonies.

This book is an analysis of the 1=10 Ritual, from the New Zealand Whare Ra Thmple. Part 1 is the ritual itself. The sec-

and part is an analysis of the ritual which includes many of the "word of mouth" teachings of both the Golden Dawn and, later, the Stella Matutina. Part 3 gives an analysis of the 1-10 Grade from the Whare Ra Temple, though its actual origin is obscure. The writing style is too erratic for R. W. Felkin, who founded and headed the temple, but reminds me very much of Ms. Felkin. The whole lecture gives a very Christian slant to the ritual. Overall, however, it has quite a few pearls of wisdom in it and should be studied with this concept in mind.

This lecture was usually read to the Zelator or Zelators directly after the ceremony, before any officers had a chance to leave the temple. Originally, we thought of blending together this analysis with our own, but, due to differences in the writing style, we decided to leave this version intact, as it was presented to every 1=10 initiate that went through Whare Ra.

This analysis is followed by a series of lectures that were handed out to the Zelator, also from Whare Ra. For the most part, this is new ground. Apart from the ritual itself, most of this material has never been published before.

Part 4 gives A. E. Waite's version of the 1=10 Ritual, plus the Allocution (explanation) of the ritual. This material was taken from a set of papers that Waite gave Felkin, though the rituals themselves are dated 1910 and are Golden Dawn in essence and format, with only some of the wording of the speeches being different. This is of some importance, for it shows that Waite was still using the Golden Dawn rituals as late as 1910. Also, his curious style deserves some airing and is not to be dismissed lightly.

Although the changes in Waite's ritual were made for the sake of change, it is evident that the entire structure is still based on the arrangement of the cipher manuscripts by MacGregor Mathers. A careful study of this ceremony shows clearly that it generates just as much power as did the original Golden Dawn 1=10 ritual. Waite was greatly respected by members of the Golden Dawn, and his knowledge was second only to that of William Wynn Westcott and Mathers (according to Felkin, who by his own admission was jealous of Waite). Waite's

books on Paracelsus and the kabbalah (qabalah) show an understanding of both alchemy and the kabbalah that very few in the Golden Dawn possessed.

We cannot overemphasize the importance of participating in, or going through, the elemental grade ceremonies. The 1=10 Ceremony is something of an enigma, for it differs a great deal from the other three elemental rituals, in the sense of magical direction. Its main concern is strengthening both the physical and astral body of the Zelator. It is not associated with any planet except the one we live on. It fuses together a number of very important magical techniques, such as tunic alchemy, the magical use of biblical Psalms, and the magical use of the *Sepher Yetzirah*. Through the diagrams on the altar and the walls, it draws from the energy of the ancient Temple of Solomon. This creates an empathy with the Earth Tablets.

The candidate is introduced to various god-forms on the Tree of Life; he will later utilize and command these in the higher levels. His advanced work will include slaying the Enochian pyramids, Enochian Chess, talismanic work, and other aspects of the Z.2 formula that the adept must utilize in the Inner Order. All of this is absorbed at a basic level by the Zelator, either directly or indirectly, but absorbed nevertheless, and is resurrected at a later level of the Order's work. It formulates a base on which to work, when one begins to work, directly, with the planetary energies.

Previous publications concerning the Golden Dawn have had a number of diagrams missing from the rituals, as well as many associated commentaries for each of the grades, even though these rituals were Golden Dawn originals. To remedy this, we have written the Z-5 series of books on both the rituals and commentaries of the Golden Dawn, from Neophyte to Adeptus Exemptus.

It has long been the assumption that the rituals of the Stella Matutina were watered-down versions of those of the Golden Dawn. This assumption was mainly due to the papers of the English temples being altered, though those in the New Zealand Order were, for the most part, identical to those of the

Golden Dawn temples, and, in some instances, included additional information.

The various diagrams presented to the candidate as he or she goes through the elemental rituals have a very specific purpose. When Whare Ra Temple was first established, a number of classes were held by Felkin. These went into specific detail about the diagrams. We were told that this was the way of teaching in the Isis-Urania Temple during the heyday of the Order prior to 1900. So, instead of just seeing a diagram on the wall during the ritual, the students were taken by their respective teachers through an entire sequence of related information at a later stage.

This practice, however, fell in abeyance in most temples after 1900, and the diagrams, once an elaborate method of study, represented a small piece of information. Judging by the later unpublished lectures of Mathers, it appears that he intended to include some of the diagrams from the 1=10 grade in his Enochian lectures for the Practicus Adeptus Minor Grade.

Both Aleister Crowley (in *The Equinox*) and Israel Regardie (in *The Complete Golden Dawn System of Magic*) did not think much of the elemental rituals. We have different opinions on this subject, mainly due to the fact that the person who put us through the grades, Jack Taylor, was an esoteric genius who had a magical power and perception I have not perceived in any other person. He knew what he was doing. Crowley told Regardie how unimpressed he was with the elemental grades, while Regardie came to the same conclusion, though both had little regard for their respective Hierophants during these rituals.

Taylor, on the other hand, could cradle your aura and introduce you to energies on one level at a time. When he showed a diagram during ritual, he would open up even more currents of energy, so that one could experience a small manifestation of what it represented. Very few people could do this—virtually none in the Golden Dawn or the Stella Matutina. If there were any who had this ability, you could probably count their numbers on the fingers of one hand.

Regardie, at dinner one night with an American temple chief

visiting in New Zealand, argued that, on the one hand, the elemental grades were unnecessary, yet, on the other hand, they were effective in opening up the aura and inflating the ego. To understand his viewpoint, you would have had to know Regardie. Taylor, however, had such abilities that many held him in awe and others feared him. He had reached the point where, when he was talking about the effectiveness of the Earth grade, he would pull these energies out of his own aura and show what he was talking about by the "show me, don't tell me" principle.

One of the let-downs within the Order was the fact that those who acted as Hierophant did not often have the same ability at ritual as people such as Taylor, Mathers, Felkin, or Waite. Although following the teachings, many unfortunately could not muster the important internal combination that every Hierophant should possess, and as a result their ritual initiations were far short of what they should have been. Mathers realized this, and while he knew he could show them the way, he could not give them the internal impetus to go with it. It's a pity that Crowley and Regardie did not have adequate Hierophants, for if they had, I am sure they would have felt the true power of the elemental ceremonies.

Taylor felt that the 5=6 grade (Adeptus Minor) was not sufficient to be a Hierophant, even though the adept had to undergo training under the Past Hierophant. This was originally done in some temples, but the practice fell into abeyance. The only remaining training was a mechanical approach to ritual that was nothing more than an empty shell. Training a Hierophant takes many years.

We have often thought that temples that are large enough should have classes to train prospective Hierophants. The students should be graded on knowledge and ability. Anyone who failed to pass should not be allowed to hold the Hierophant's position.

When people, both within and without the Order, start talking about shortcuts such as skipping the elemental grades, we are reminded of the story on the formation of the golem of

Prague. Rabbi Yehuda ben Bezalel (Maharal) could have saved himself a lot of trouble in bringing life to the golem if he had not used the elements—or could he?

One of the recent buzzwords used by Golden Dawn aspirants, and unfortunately by some Chiefs, is "conceptionalize"—which should read "cop-out." This approach is generally advocated by those armchair magicians who talk instead of doing. Some of them would have us change the Golden Dawn system into sitting back and visualizing the whole ritual procedure. These people are either too lazy or do not have the ability to perform Golden Dawn ritual. They think that Will alone will suffice, which it will not. The prime ingredient of ritual is to get out there and do it, not just sit back and theorize about it.

The commentary and explanations of the Z-5, Books 2-4 (the 1=10 to the 4=7 grades), were originally a series of four lectures that were part of the 6=5 grade teachings (the explanations of the Portal and 5=6 being part of the 7=4 grade) of the Thoth-Hermes Temple. I have taken the liberty of expanding these somewhat and adding in the Outer Order study program with them.

**—Pat and Chris Zalewski
New Zealand, 1988**

Part 1

The Ritual

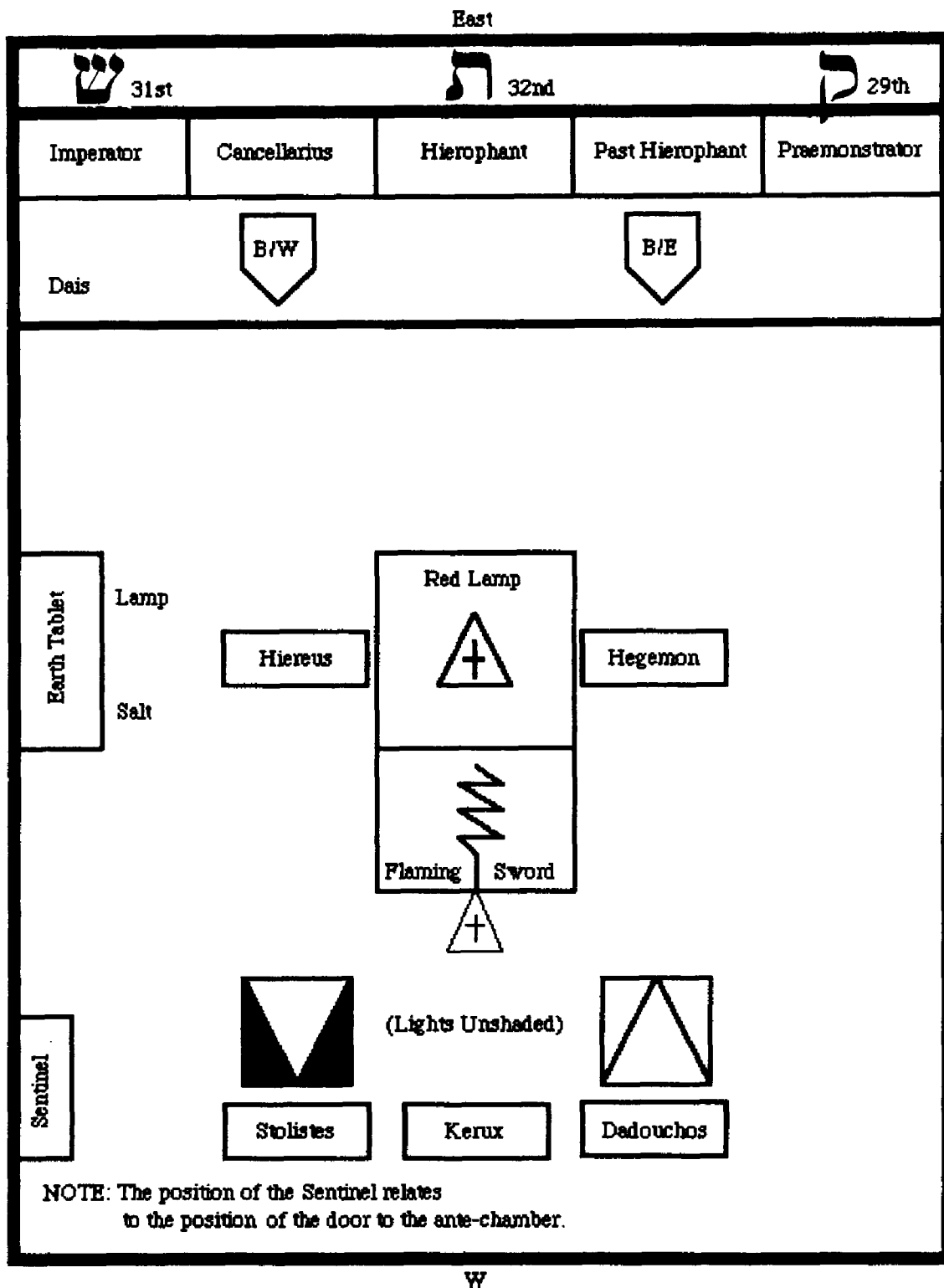

Temple Arrangement—First Part

Ceremony of the 1=10 Grade of Zelator

Officers

On the dais: Imperator, Cancellarius, Praemonstrator, Past Hierophant, Hierophant

(The first four of these officers are optional at this point.)

In the hall: Hiereus, Hegemon, Kerux, Stolistes, Dadouchos, Sentinel

Requirements

Hoodwink, Sash, Fylfot Cross, Three Portals, Shewbread Diagram, Candlestick Diagram, Altar of Incense Diagram, Triangle Diagram, Diagram on Altar, Earth Tablet.

***Note:* If this ceremony is the first to be performed at any meeting, the regulation with regard to the use of the Lesser Ritual of the Pentagram and the prayer to the East holds good, as laid down in the rubric of the 0=0 Grade.**

Opening

The members being assembled and robed, and seated each in his/her proper place:

Hiereus: (Gives one knock)

Hierophant: *Fraters and Sorores of the 1=10 Grade of the Stella Matutina, assist me to open the temple in the Grade of Zelator. Frater (Soror) Kerux, see that the Temple is properly guarded.*

(Kerux knocks without opening door. Sentinel replies with one knock.)

Kerux: *Very Honored Hierophant, the Temple is properly guarded.*

Hierophant: *Honored Hiereus, see that none below the Grade of Zelator is present.*

Hiereus: *Fraters et Sorores, give the sign of the 1=10.*

(All give the signs of Zelator. Hiereus gives sign.)

Hiereus: *Very Honored Hierophant, no one below the Grade of Zelator is present.*

(Hierophant gives sign.)

Hierophant: *Purify and consecrate the Temple with Water and Fire.*

(Kerux advances between the Pillars. Stolistes and Dadouchos, one each side of the Pillars, advance to center of the hall. All salute. Dadouchos makes a cross in the air with the censer and swings it forward three times.)

Dadouchos: *I consecrate with Fire.*

(Stolistes makes a cross with cup and sprinkles thrice towards the East while saying:)

Stolistes: *I purify with Water.*

Kerux: *The Temple is cleansed.*

(All salute; all three retire, Kerux leading and passing with Sol.)

Hierophant: *Let the Element of this Grade be named that it may be awakened in the spheres of those and in the sphere of the Order.*

Hegemon: *The Element of Earth.*

(Hiereus gives one knock.)

Hiereus: *Let us adore the Lord and King of the Earth.*

(All face East.)

Hierophant: *Adonai Ha Aretz. Adonai Melechl Unto Thee be the Kingdom, the Power (makes a circle) and the Glory. Malkuth (makes a cross), Geburah, Gedulah.*

(Hierophant makes a circle and cross with scepter before him.)

The Rose of Sharon and the Lily of the Valley. Amen.

(All give Zelator Sign. Kerux goes to North and sprinkles salt before the Tablet while saying:)

Kerux: *Let the Earth adore Adonai.*

(Hierophant leaves his/her place and goes to North. S/he stands facing the center of the Tablet of the North, and at a convenient distance therefrom [see diagram, page 70]. Hiereus takes his/her place at the right side of Hierophant, Hegemon on the left side of Hierophant, Stolistes and Dadouchos behind Hegemon. All officers face North. Hierophant makes Invoking Pentagonagram of Earth in the air in front of, and concentric with, the Tablet of the North, saying:)

Hierophant: *And the Elohim said, "Let us make Adam in Our Image, after our likeness let him have dominion over the fish of the sea and over the fowl of the air and over the cattle and over all of the Earth and over every creeping thing that creepeth over the Earth."*

And Elohim created Eth ha Adam in their own Image, in the Image of Elohim created they them. In the name of Adonai Melekh and of the Bride and Queen of the Kingdom, Spirits of Earth adore Adonai!

(Hierophant hands his scepter to Hiereus, and taking sword makes the Sign of the Ox in the center of the pentagram, saying:)

Hierophant: *In the Name of Auriel, the Great Archangel of Earth, and by the sign of the Head of the Ox, Spirits of Earth, Adore Adonai!*

(Hierophant returns sword to Hiereus then takes miter-headed scepter from Hegemon and makes a cross in the air, saying:)

Hierophant: *In the Names and Letters of the Great Northern Quadrangle, Spirits of Earth, adore Adonai!*

(Hierophant returns scepter to Hegemon and takes the cup from Stolistes, makes a cross, and sprinkles thrice to the North, saying:)

Hierophant: *In the Three Great Secret Names of God borne upon the Banners of the North—EMOR DIAL HECTEGA—Spirits of Earth, adore Adonai!*

(Hierophant returns cup to Stolistes and takes censer from Dadouchos, makes a cross and three forward swings, and says:)

Hierophant: *In the Name of IC ZOD HEH CHAL, Great King of the North, Spirits of Earth adore Adonai!*

(Hierophant returns censer to Dadouchos and, taking back scepter from Hiereus, returns to Throne. All officers return to their places by way of Sol. All members face as usual.)

Hierophant: **(Knocks four times, knocks three times, then knocks three more times)**

Hegemon: **(Knocks four times, knocks three times, then knocks three more times)**

Hiereus: (Knocks four times, knocks three times, then knocks three more times)

Advancement: First Part

(Hierophant sits East of Altar. Hiereus sits North of Altar. Hegemon sits South of Altar.)

Hierophant: *Fraters and Sorores, our Frater (Soror), having made such progress in the Paths of the Occult Science as has enabled him/her to pass an examination in the required knowledge, is now eligible for advancement to this Grade, and I have duly received a dispensation from the Greatly Honored Chiefs of the Second Order to admit him (her) in due form. Honored Hegemon, superintend the preparation of the Neophyte and give the customary alarm.*

(Hegemon salutes with 1=10 sign, and leaves the room by South and West. Sentinel prepares Neophyte, who wears sash of 0=0 Grade and is blindfolded. S/he carries a Fylfot Cross in his/her right hand. Hegemon instructs Neophyte in the knocks of the Grade. Kerux opens the door until it is just ajar.)

Hegemon: *Let me enter the Portal of Wisdom.*

Kerux: *I will.*

(Kerux opens door and lets them in. Sentinel turns down lights.)

Hierophant: *Except Adonai build the house, their labor is but lost that build it. Except Adonai keep the city, the watchman waketh in vain. Frater (Soror) Neophyte, by what aid dost thou seek admission to the 1=10 grade of the Stella Matutina?*

(Hegemon answers for Neophyte.)

Hegemon: *By the guidance of Adonai; by the possession of the necessary knowledge; by the dispensation of the Greatly Honored Chiefs of the Second Order; by the signs and token*

of the 1=10 Grade: by this symbol of the Hermetic Cross.

(Kerux takes cross from Hegemon.)

Hierophant: *Give the step and signs of the Neophyte.*

(Neophyte gives them)

Hierophant: *Frater Kerux, receive from the Neophyte the Token, Grand Word, and Password of the 0=0 Grade.*

(Kerux places himself in front of Neophyte.)

Kerux: *Give me the Grip of the Neophyte.*

(Neophyte gives Grip.)

Kerux: *Give me the Word.*

(Neophyte gives Word.)

Kerux: *Give me the Password.*

(Neophyte gives Password. Kerux turns to Hierophant and gives Grade salute.)

Kerux: *Very Honored Hierophant, I have received them.*

(Hierophant instructs Hegemon.)

Hierophant: *Lead the Neophyte to the West and set him 1 her between the Mystic Pillars, with his/her face towards the East.*

(Hegemon places Neophyte between the Pillars.)

Hierophant: *Frater (Soror) _____ , will you pledge yourself to maintain the same secrecy regarding the Mysteries of this Grade as you are pledged to maintain regarding those of the 0=0 Grade—never to reveal them to the world, and not to even confer them upon a Neophyte, without a dispensation from the Greatly Honored Chiefs of the Second Order?*

Neophyte: *I will.*

Hierophant: *Then you will kneel on both your knees, lay your right hand on the ground, and say: "I swear by the Earth whereon I kneel."*

(Neophyte makes pledge.)

Hierophant: *Let the symbol of blindness be removed.*

(Hegemon unbinds Neophyte's eyes. Sentinel turns up lights. Hegemon goes back to his/her proper place. Neophyte remains kneeling between Pillars with his/her hand on the ground. Kerux takes the salt from before the Tablet of the North and, passing round the Altar with Sol, stands in front of Neophyte, facing him/her, and holding the salt in front of him/her.)

Kerux: *Take salt with your left hand and cast it to the North; saying: "Let the Powers of Earth witness my pledge."*

(Neophyte makes pledge. Kerux replaces salt, and returns to his/her place.)

Hierophant: *Let the Neophyte rise and let him 1 her be purified with. Water and consecrated with Fire, in confirmation of his /her pledge, and in the Name of the Lord of the Universe who works in silence and whom naught but silence can express.*

(Dadouchos comes forward, around South Pillar, stands before Neophyte, and makes a cross and three forward swings of the censer, saying:)

Dadouchos: *In the name of the Lord of the Universe, who works in silence and whom naught but silence can express, I consecrate thee with Fire.*

(Dadouchos returns by the way s/he came. Stolistes comes round North Pillar, stands before Neophyte, makes cross on forehead, and sprinkles thrice, saying:)

Stolistes: *In the name of the Lord of the Universe, who works in silence and whom naught but silence can express, I purify thee with Water.*

(Stolistes returns to place as s/he came.)

Hierophant: *The 1=10 Grade of Zelator is a preparation for other Grades, a threshold before our discipline, and it shows by its imagery, the Light of the Hidden Knowledge dawning in Darkness of Creation; and you are now to begin to analyze and comprehend the Nature of the Light. In this end, you stand between the Pillars, in the Gateway where the secrets of the 0=0 Grade were communicated to you.*

Prepare to enter the immeasurable regions.

"And Tetragrammaton Elohim planted a Garden Eastward in Eden, and out of the ground made Tetragrammaton Elohim to grow every tree that is pleasant to the sight and good for food; the Tree of Life also, in the midst of the Garden, and the Tree of Knowledge of Good and of Evil." This is the Tree that has two Paths, and it is the tenth Sephirah, Malkuth, and it has about it seven columns, and the Four Splendors whirl around it a vision of the Merkabah of Ezekiel; and from Gedulah it drives an influx of mercy, and from Geburah it drives an influx of severity, and the Tree of Knowledge of Good and of Evil shall it be until it is united with Supernals in Daath. But the Good which is under it is the Archangel Metatron, and the Evil is called the Archangel Samael, and between them lies the straight and narrow way, where the Archangel Sandalphon keeps watch. The souls and the angels are above its branches, and the qliphoth or demons dwell under its roots.

Let the Neophyte enter the Pathway of Evil.

(Kerux takes his place in front of Neophyte, leads him/her in a northeast direction towards the Hieres, halts and steps out of the direct line between Hieres and Neophyte.)

Hieres: *Whence comest thou?*

Kerux: *I come from between the two Pillars, and I seek the Light of the Hidden Knowledge in the Name of Adonai.*

Hieres: *And the Great Angel Samael answered, and said: "I am*

the Prince of Darkness and of Night. The foolish and rebellious gaze upon the face of the created World, and find therein nothing but terror and obscurity. It is to them the terror of Darkness and they are drunken men stumbling in the Darkness. Return, for thou canst not pass me by."

(Kerux leads Neophyte back as s/he came, to between the Pillars.)

Hierophant: *Let the Neophyte enter the Pathway of Good.*

(Kerux leads Neophyte southeast, and halts opposite. Hegemon, stepping aside from before Neophyte.)

Hegemon: *Whence comest thou?*

Kerux: *I come from between the Pillars, and I seek the Light of the Hidden Knowledge in the Name of Adonai.*

Hegemon: *The Great Angel Metatron answered, and said: "I am the Angel of the Presence Divine. The Wise gaze upon the Created World and behold there the dazzling image of the Creator. Not Yet can thine eyes bear that dazzling image of the Creator. Not yet can thine eyes bear that dazzling Image. Return, for thou canst not pass me by."*

(Kerux turns and leads Neophyte back between the Pillars.)

Hierophant: *Let the Neophyte enter the straight and narrow Pathway which turns neither to the right hand nor to the left hand.*

(Kerux leads Neophyte directly up center of hall until s/he is near the Altar and steps aside from before Neophyte, leaving him/her to face the Altar unobstructed. Hierus and Hegemon speak together:)

Hierus
: *Whence comest thou?*

Hegemon

(Hierus and Hegemon cross scepter and sword before Altar.)

Kerux: *I come from between the Pillars and I seek the Light of the Hidden Knowledge in the Name of Adonai.*

(Hierophant advances to East of the Altar with scepter of Hegemon and, raising it to an angle of 45 degrees, says:)

Hierophant: *But the Great Angel Sandalphon said: "I am the reconciler for Earth, and the Celestial Soul therein. Form is invisible alike in Darkness and in blinding Light. I am the left-hand Kerub of the Ark and the feminine power, as Metatron is the right-hand Kerub and the masculine power, and I prepare the way for the Celestial Light."*

(Hegemon and Hiererus step back to South and North of Altar, respectively. Hierophant takes Neophyte by right hand, with his/her left, and pointing to the Altar and diagram, says:)

Hierophant: *And Tetragrammaton placed Kerubim at the East of the Garden of Eden and a Flaming Sword which turned every way to keep the Path of the Tree of Life, for He has created Nature that Man, being cast out of Eden, may not fall into the Void. He has bound Man with the Stars, as with the chain. He allures him with scattered fragments of the Divine Body in bird and beast and flower, and he laments over him in the Wind and the Sea and in the Birds. When the time is ended, he will call the Kerubim from the East of the Garden, and he shall be consumed and become infinite and holy.*

Receive now the Secrets of this Grade. The step is thus given: 6 by 6, showing you passed the threshold. The Sign is given by raising the right hand to an angle of 45 degrees. It is the position in which the Hierophant interposed for you between the Hiererus and the Hegemon. The Token is given by grasping fingers, thumb touching thumb, to form a triangle. It refers to the Ten Sephiroth. The Word is Adonai Ha-Aretz, and means Adonai the Lord of the Earth, to which Element this Grade is allotted. The Mystic Number is 55, and from it is formed the Password, Nun Heh. It means Ornament, and when given is lettered separately.

The Badge of this Grade is the sash of the Neophyte with the narrow white border, a red cross within the triangle, and the number 1 within a circle and 10 within a square, one on each side of the triangle.

(Hierophant invests Neophyte with the sash and points out the Three Portals.)

Hierophant: *The Three Portals facing you in the East are the gates of the Paths leading to three further Grades, which, with the Zelator and the Neophyte, form the First and Lowest Order of our Fraternity. Furthermore, they represent the paths which connect the tenth Sephirah, Malkuth, with the other Sephiroth. The letters Tau, Qoph, and Shin make the word **Qesheth**—a Bow, the reflection of the Rainbow of Promise stretched over our Earth, and which is about the Throne of God.*

(Hierophant resumes Throne. Hegemon points out the Flaming Sword, saying:)

Hegemon: *This drawing of the Flaming Sword of the Kerubim is a representation of the Guardians of the Gates of Eden, just as the Hieres and Hegemon symbolize the two paths of the Tree of Knowledge of Good and of Evil.*

Hieres: *In this Grade, the red cross is placed within the white triangle upon the Altar, and it is thus the symbol of the Banner of the West. The triangle refers to the three paths and the cross to the Hidden Knowledge. The cross and the triangle together represent Life and Light.*

(Hierophant points out the Tablet of the North, saying:)

Hierophant: *This Grade is especially referred to the Element of Earth, and therefore one of its principle emblems is the Great Watchtower or Terrestrial Tablet of the North. It is the Third or Great Northern Quadrangle, or Earth Tablet, and it is one of the four Great Tablets of the Elements said to have been given to Enoch by the great Angel Ave. It is*

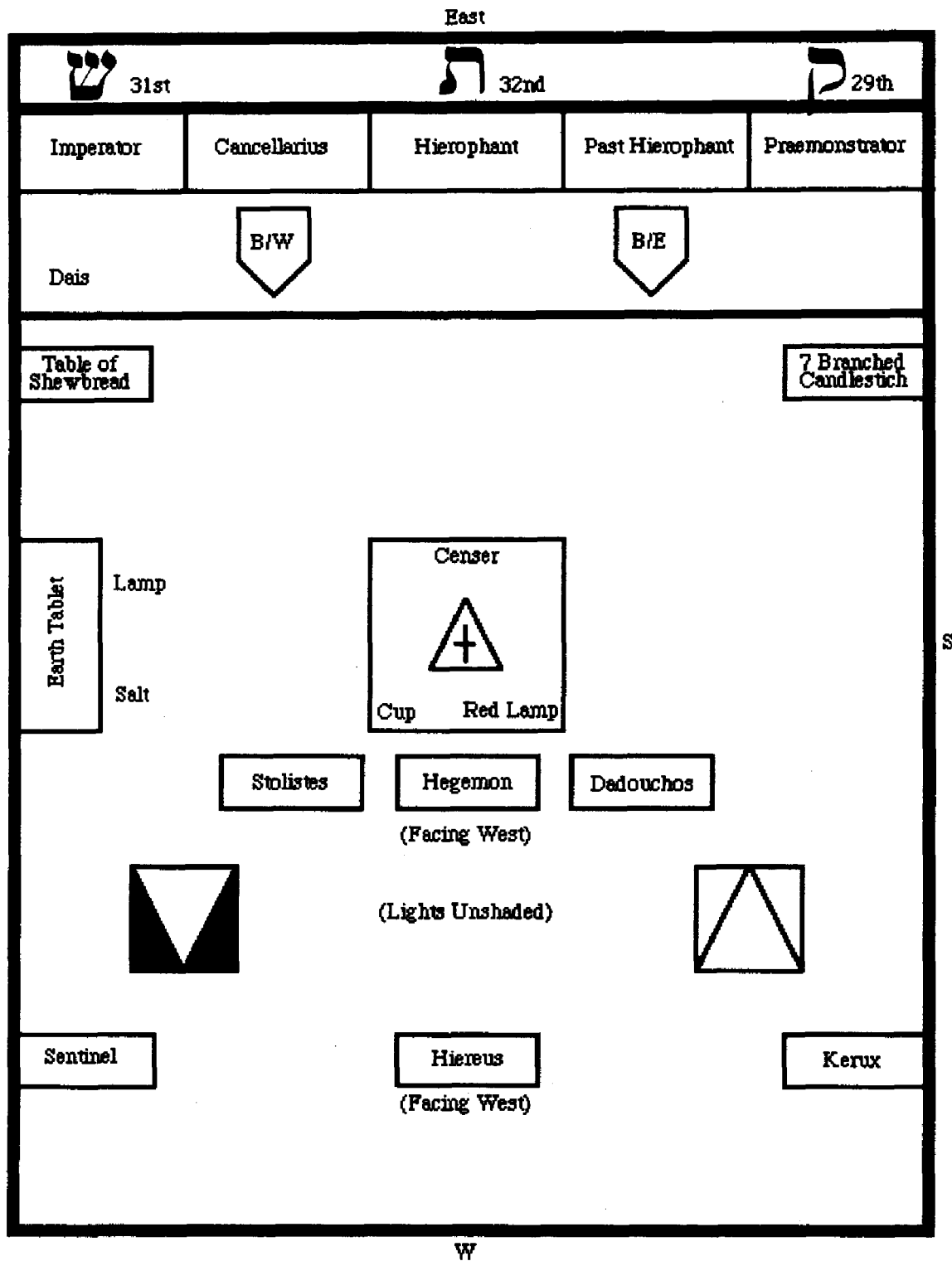

Temple Arrangement—Second Part

divided within itself into four lesser angles. The mystic letters upon it form various divine and angelic Names, in what our tradition call the Angelic Secret Language. From it are drawn the Three Holy Secret Names of God, EMOR DIAL HECTEGA, which are borne upon the Banners of the North, and there are also numberless name of angels, archangels, and spirits ruling the element of Earth.

(Kerux comes forward and hands Fylfot Cross to Hierophant.)

Hierophant: *The Hermetic Cross, which is also called the Fylfot, Hammer of Thor, and Swastika, is formed of 17 squares out of a square of 25 lesser squares. These 17 represent the Sun, the Four Elements, and the Twelve Signs of the Zodiac. In this Grade, the Lights on the Pillars are unshaded, showing that you have quitted the Darkness of the Outer World. You will leave the Temple for a short time.*

(Kerux takes Neophyte out.)

Second Part

(Temple arranged as in Diagram.)

Hierophant: *Frater (Soror) Kerux, when the Neophyte gives the proper alarm, you will admit him. Frater(s) (Soror(s)) Stolistes and Dadouchos, assist the Kerux in the reception.*

(Kerux goes out and instructs the Neophyte in the knocks. Stolistes and Dadouchos take up positions so as to face Neophyte as s/he enters hall. Kerux opens door and admits Neophyte, but does not stand in front of him/her.)

Hierophant: *Frater (Soror) _____, as in the Grade of Neophyte, you came out of the World to the Gateway of Hidden Knowledge, so in this Grade you pass through the Gateway and come into the Holy Place. You are now in the court of the Tabernacle, where stood the Altar of Burnt Offering, whereon was offered the sacrifices of animals, which symbolized the Qlipoth, or Evil Demons, who inhabit the*

plane contiguous to and below the Material Universe.

(Dadouchos makes a cross in the air with censer and censes Neophyte in silence with three forward swings.)

Hierophant: *Between the Altar and the entrance to the Holy Place stood the Laver of Brass, wherein the priest washed before entering the Tabernacle. It was the symbol of the Waters of Creation.*

(Stolistes makes a cross with water, on Neophyte's forehead and sprinkles thrice in silence.)

Hierophant: *Having made offering at the Altar of Burnt Sacrifice, and having been cleansed at the Laver of Brass, the Priest then entered the Holy Place.*

(Kerux takes Neophyte behind Pillars, to North. Stolistes and Dadouchos return to their places. Hiereus takes his/her stand between the Pillars [Kerux having removed the chair] facing Neophyte. S/he guards the path with his/her sword.)

Hiereus: *Thou canst not pass the gateway which is between the Pillars unless thou canst give the Signs and the Words of the Neophyte.*

(Neophyte gives them and, instructed by the Kerux, advances to a position between the Pillars. Hiereus returns to place in the West. Hegemon comes forward, stands East of Pillars facing Neophyte, and bars the way into the Temple with scepter.)

Hegemon: *Thou canst not enter the Holy Place unless thou canst give the Sign and Grip of the Zelator.*

(Neophyte gives them. Kerux resumes his/her seat, after handing Neophyte over to charge of Hegemon. Hegemon leads Neophyte to the North.)

Hegemon: *To the Northern side of the Holy Table stood the Table of Shewbread. The drawing before you represents its occult meaning. On it, twelve loaves were laid as emblems of the Bread of Life, and it is an image of the Mystery of the Rose*

of Creation. The twelve circles are the Twelve Signs of the Zodiac, while the lamp in the center is symbolic of the Sun, which is the source of heat and life. The four triangles, whose twelve angles each touch one of the twelve circles, are those of Fire, Earth, Air, and Water, and allude to the four Triplicities of the Zodiac Signs. The triangle inscribed within each of the twelve circles alludes to the three decanates, or phases of ten degrees of each sign. On one side of each triangle is the permutation of Yod Heh Vau Heh which is referred to that particular sign, while on the opposite side of it is the name of one of the Twelve Tribes which are also attributed to it.

Now the 22 sounds and letters of the Hebrew alphabet are the foundation of all things. Three Mothers, Seven Double, and Twelve Simple Letters are allotted to the twelve directions in space, and those diverge to infinity and are in the arms of the Eternal. These twelve letters He designed and combined and formed with the twelve celestial constellations of the Zodiac. They are over the Universe as a king traversing his dominions, and they are in the heart of man as a king in warfare.

And the Twelve Loaves are the images of those ideas, and are the outer petals of the Rose; while within are the Four Archangels, ruling over the Four Quarters, and the kerubic emblems of the Lion, Man, Bull, and Eagle. Around the great central Lamp, which is an image of the Sun, is the Great Mother of Heaven, symbolized by the letter Heh, the first of the Simple Letters, and by its number five, the pentagram, Malkah the Bride, ruling her Kingdom Malkuth, crowned with a crown of Twelve Stars.

These twelve circles further represent the Twelve Foundations of the Holy City of the Apocalypse, while in Christian symbolism the Sun and the Twelve signs are referred to Christ and his Twelve Apostles.

(Hegemon leads Neophyte to Hiereus, and then returns to place and is seated. Hiereus leads Neophyte to the South.)

Hiereus: *On the Southern side of the Holy Place stood the Seven-Branched Candlestick wherein was burned pure olive oil. It is an Image of the Mystery of Elohim, the Seven Creative Ideas. The symbolic drawing before you represents its occult meaning. The seven circles which surround the heptagram represent the Seven Planets and the Seven Qabbalistic Palaces of Assiah, the Material World, which answer to the Seven Apocalyptic Churches, which are in Asia or Assiah, as these allude to the Seven Lamps before the Throne on another plane.*

Within each circle is a triangle to represent the Threefold Creative Idea operating in all things. On the right-hand side of each is the Hebrew name of the angel who governs the planet; on the left side is the Hebrew name of the sphere of the planet itself; while the Hebrew letter beneath the base is one of the duplicated letters of the Hebrew alphabet which refers to the Seven Planets.

The seven Double Letters of the Hebrew alphabet have each two sounds associated with them, one hard, one soft. They are called "double" because each letter represents a contrary or permutation, thus: Life and Death; Peace and War; Wisdom and Folly; Riches and Poverty; Grace and Indignity; Fertility and Solitude; Power and Servitude.

These seven letters point out seven localities: Zenith, Nadir, East, West, North, South, and the Place of the Holiness in the midst sustaining all things. The Archetypal Creator designed, produced, combined, and formed with them the planets of the Universe, the days of the week, and in man, the gate of the soul. He has loved and blessed the number seven more than all things under His Throne. The powers of these seven letters are also shown forth in the Seven Palaces of Assiah, and the seven stars of that vision

are the seven archangels who rule them.

(Hierous leads Neophyte to Hierophant and returns to place and is seated. Hierophant leads Neophyte to Altar, takes censer from Altar and, holding it with chain short, makes cross and three forward swings.)

Hierophant: *Before the Veil of the Holy of Holies stood the Altar of Incense, of which this Altar is an image. It was of the form of a double cube, thus representing material form as a reflection and duplication of that which is spiritual. The side of the Altar, together with the top and bottom, consists of ten squares, thus symbolizing the Ten Sephiroth, of which the basal one is Malkuth, the realization of the rest upon the material plane, behind which the others are concealed. For were this double cube raised in the air immediately above your head, you would but see the single square forming the lowest side, the others from their positions being concealed from you. Just so, behind the material Universe lies the concealed form of the majesty of God.*

The Altar of Incense was overlaid with gold to represent the highest degree of purity, but the Altar before you is black to represent the terrestrial Earth. Learn then to separate the pure from the impure, and refine the Gold of the Spirit from the Black Dragon, the corruptible body. Upon the Cubical Altar were Fire, Water, and Incense, the Three Mother Letters of the Hebrew alphabet: Aleph, Mem, and Shin. Mem is silent, Shin is sibilant, and Aleph is the tongue of a balance between these contraries in equilibrium, reconciling and mediating between them. In this is a great mystery, very admirable and recondite. The Fire produced the Heavens, the Water, and the Earth, and the Air is the reconciler between them. In the year, they bring forth the hot, the cold, and the temperate seasons, and in man they are imaged in the head, the chest, and the trunk.

I now confer upon you the mystic title of Periclinus (Peri-

dine) de Faustis, which signifies that on this Earth you are in a wilderness, far from the Garden of the Happy.

And I give you the symbol of ARETZ, which is the Hebrew name for Earth, to which the 1=10 Grade of Zelator is referred. The word Zelator is derived from the ancient Egyptian Zaruator, signifying, "Searcher of Athor," Goddess of Nature; but others assign it to the meaning of the **zealous student, whose first duty was to blow the Athanor of Fire which heated the crucible of the Alchemist.**

(Hierophant resumes seat on the Dais; Kerux leads new Zelator to a seat in the Northwest.)

Hierophant: **Frater Kerux, you have my command to declare that our Frater (Soror) has been duly admitted to the 1=10 Grade of Zelator.**

(Kerux comes to the Northwest of Hierophant, faces West, and raises wand.)

Kerux: *In the Name of Adonai Melekh, and by command of the Very Honored Hierophant, hear ye all that I proclaim that Frater (Soror)_____ has been duly admitted to the 1=10 Grade of Zelator, and that he /she has obtained the mystic title of Periclinus (Pericline) de Faustis and the symbol of Aretz.*

(Kerux returns to place by East, saluting, and by South and West.)

Hierophant: *In the Zelator Grade, the symbolism of the tenth Sephirah Malkuth is especially shown, as well as the tenth Path of the Sepher Yetzirah. Among other Mystic Titles, Malkuth is called SHAAR, the Gate, which has the same number as the Great Name ADONAI written in full: Aleph, Daleth, Nun, Yod, which is also called "Gate of Death," "The Gate of Tears," and "The Gate of Justice," "The Gate of Prayer," and "The Gate of the Daughter of the Mighty Ones." It is also called "The Gate of the Garden of Eden"*

and "The Inferior Mother," and in Christian symbolism is connected with the Three Holy Women at the foot of the cross. The tenth path of the Sepher Yetzirah, which answereth to Malkuth, is called "The Resplendent Intelligence," because it exalts above every head and sitteth upon the Throne of Binah. It illuminateth the Splendor of all the Lights (the Zohar ME-OUROTH) and causeth the current of the Divine Influx to descend from the Prince of Countenances, the great archangel, Metatron.

Frater (Soror) _____, before you can be eligible for advancement, to the next grade of 2=9, you will be required to pass an examination on the following subjects:

1. Names and symbols of the Three Principles.
2. Metals attributed to the Seven Planets.
3. The meaning of the special alchemical terms: Sun, Moon, King, etc.
4. Names and meanings of the 12 astrological houses.
5. Names and meanings of the planetary aspects.
6. Names and meanings of the Querent and Quesited.
7. The four great classes of astrology.
8. The arrangement of the Tree of Life.
9. The names of the Four Orders of the Elements.
10. The Three Pillars of the Tree of Life.
11. The names and forms of the Kerubim.
12. Meanings of the Laver, Altar, and Qlippoth.
13. The Names of the Ten Houses of Assiah.
14. Names of the Four Worlds of the Qabalists.
15. Names of the 22 trumps and four suits.

A manuscript on these will be supplied to you. When you are well satisfied that you are well informed on these, notify the Officer in Charge.

Closing

Hierophant: *Fraters and Sorores, assist me to close this temple in the 1=10 Grade of Zelator.*

(All rise.)

Hierophant: *Frater (Soror) Kerux, see that the temple is properly guarded.*

(Kerux knocks on inner side of door. Sentinel returns knock.)

Kerux: *Very Honored Hierophant, the Temple is properly guarded.*

Hierophant: *Let us adore the Lord and King of the Earth.*

(All face East.)

Hierophant: *ADONAI ha-ARETZ, ADONAI MELEKH, Blessed be Thy name unto the countless ages. AMEN.*

(Hierophant gives signs. All give sign and face as usual. Hierophant leaves his/her throne and passes to the North, standing before the Tablet of the North. Hieres stands on the right of the Hierophant, Hegemon on left hand, Kerux behind Hierophant, Stolistes behind Hegemon, Dadouchos behind Hierophant. Other members behind officers, in alternating lines of sexes where possible.)

Hierophant: *Let us rehearse the prayer of the Earth Spirits.*

O, Invisible King, Who, taking the Earth for Foundation, didst hallow its depths to fill them with Thy Almighty Power. Whose Name shaketh the Arches of the World, Thou who causeth the Seven Metals to flow in the veins of the rocks, King of the Seven Lights, Rewarder of the subterranean workers, lead us into desirable Air and into the Realm of Splendor. We watch and we labor unceasingly. We seek and we hope, by the 12 Stones of the Holy City, by the buried Talismans, by the Axis of the Loadstone, which passes through the center of the Earth-O Lord, O Lord, O

Lord! Have pity upon those who suffer. Expand our hearts, unbind and upraise our minds, enlarge our natures. O Stability and Motion! O Master who never dost withhold the wages of Thy Workmen! O Silver Whiteness-O Golden Splendor! O Crown of Living and harmonious Diamond! Thou who wearest the heavens on Thy Finger like a ring of Sapphire! Thou who hidest beneath the earth in the Kingdom of Gems, the marvelous Seed of the Stars! Live, reign, and be Thou Eternal Dispenser of the treasures whereof thou hast made us the Wardens. (Pause)

Depart ye in peace into your abodes. May the blessing of Adonai be upon you. (Makes banishing pentagram of Earth.) Be there peace between us and you, and be ye ready to come when ye are called.

(All return to places and face as usual.)

Hierophant: *In the name of Adonai Melekh, I declare this temple closed in the Grade of Zelator.*

Hierophant: (Makes one battery of four, three, and three knocks)

Hiereus: (Makes one battery of four, three, and three knocks)

Hegemon: (Makes one battery of four, three, and three knocks)

(Candidate is led out by Hegemon.)

Part 2

The Commentary

The 1=10 Earth Grade of Zelator

The Zelator Grade of the Golden Dawn relates to the element of Earth and the kabbalistic Sephirah of Malkuth. It is the second of the Golden Dawn initiations, the first being the grade of Neophyte. (See *Z-5: Secret Teachings of the Golden Dawn—Book I: The Neophyte Ritual 0=0* by Pat Zalewski, Llewellyn, 1991, for a full commentary on the Neophyte Ritual.) The state produced by the 0=0 Ritual has been described by some occult authors as being similar to alchemical dissolution. The effect of this first ceremony is vital to the ensuing elemental grades. The 1-10 grade lays the ground for further auric manipulations that the candidate must go through.

The Zelator Grade is more than just an introduction to the ray or power of the Element of Earth. It is a means by which many things analogous to Earth in nature are introduced to the advancing Neophyte. This is done on a level that the candidate would not have recognized before the initiation, due to the subjective influence of the Order itself. The candidate undergoes

changes, or transmutations, within his or her psychological makeup after exposure to the auric manipulations of the ritual. This can manifest during, or after, the initiatory process.

In layman's terms, the Earth Grade of Zelator is said to "ground" the student's aura by giving him or her a sense of proportion. This will manifest itself on both the etheric levels of the body and on a day-to-day basis.

Some Golden Dawn people consider the elemental grades to be unimportant. They have substituted ceremonies such as the "Opening by Watchtower" instead of going through the elemental grades. Jack Taylor, however, was very adamant that every student should go through the elemental grades. He felt the grades exerted a positive influence on many levels of the student's life.

Using the Opening by Watchtower as a replacement for the elemental grades can cause unexpected problems. When doing this type of ceremony as an initiation, the aura becomes impregnated with one or more of the Elements. The aura of a novice is not given adequate time to adjust to the vibrational rate. Mass confusion can develop because the individual Elements do not have a chance to strengthen and balance each other in correct sequence. The subtle stops and prompts within the Zelator Ritual do not appear in the Watchtower ceremony, and these have a very real place in the Earth Ritual.

The Zelator Grade is the first of the four main filtration processes of the Outer Order of the Golden Dawn. This ceremony is supposed to try to make the student who seeks to join the Order as a means of escape from reality face up to his or her obligations in the Outer World rather than retreat from them. Before any firm development can be undertaken, life must be faced head on; otherwise, these problems will manifest repeatedly when the student goes on to the next levels. If the Zelator Ritual has been performed correctly, then many of those who attain this level as a form of escapism drop out due to the influence of this ceremony. Also, the influence of it will sometimes spill over into the other grade levels—if the student has had insufficient time for this process to manifest itself.

For those people who are earthly by nature; this ceremony will reinforce their strengths without hindering their progress into the next level. There are some who have an earthly nature and a narrow outlook. This grade is designed to widen their field of vision and to show them the practical aspects of their natures. It is done without undue constriction of their intellectual pursuits, by committing themselves to the ideals set by the Order's framework.

The Zelator Grade is also directly related to the *Guph*, or physical body, of the aspirant. When the candidate goes through the ritual, the etheric energies impregnate the aura. This is done to strengthen the body for the trials and tribulations it will undergo as the pressure of the Order's teachings and magnetic manipulations start to take their toll. By this, we do not mean that the ritual will cause ill health. Rather, like homeopathy and natural systems of healing, it may cause dormant illnesses to come to the surface. One of the bodily systems on which this level seems to work best is the alimentary system, the function of which is to expel waste products and poisons from the body. Any dormant illness revealed by the ritual should be confronted and hopefully healed before further advancement through the grades.

In the Golden Dawn paper, "The Microcosm—Man," a very technical description is given of the actions of the kabbalistic soul as applied to the lowest Sefirah, Malkuth. This description is worth repeating, because it shows in detail some of the things the candidate will experience:

From Malkuth is formed the whole of the physical body under the command and presidency of the Nephesch. The Nephesch is the subtle body of refined astral Light upon which, as on an invisible pattern, the physical body is extended. The physical body is permeated throughout by the rays of the Ruach, of which it is the material completion., The Nephesch shineth through the Material body and formal' the Magical Mirror or Sphere of Sensation. This Magical Mirror or Sphere of Sensation is an imitation or copy of the Sphere of the Universe. The space between the physical body and the

boundary of the sphere of Sensation is occupied by the ether of the astral world; that is to say, the container or recipient of the Astral rays of the Microcosm.

The Nephesch is divided into its seven Palaces, combining the Sephirotic influences in their most material forms. That is, the world of passions dominated by the Ruach, or by the world which is beyond. That is, its Sephiroth are passionate, expressing a passionate dominion. Thus, its three Supernal Sephiroth, Kether, Chokmah and Binah, are united in a sense of feeling and comprehending impressions. Its Chesed is expressed by laxity of action. Its Geburah by violence of action. Its Tiphareth is expressed by more or less sensual contemplation of beauty, and love of vital sensation. Its Hod and Netzach, by physical well-being and health. Its Yesod, by physical desires and gratifications. Its Malkuth by absolute increase and domination of matter in the material body.

The Nephesch is the real, the actual body, of which the material body is only the result through the action of Ruach, which by the aid of the Nephesch, formeth the material body by the rays of Ruach, which do not ordinarily proceed beyond the limits of the physical body. That is to say, in the ordinary man the rays of Ruach rarely penetrate into the sphere of Sensation.

Shining through infinite worlds, and darting its rays through the confines of space, in this Sphere of Sensation is a faculty placed even as a light is placed within a lantern. This is a certain sense placed in an aperture of the upper part of the Ruach wherein act the rays from Chokmah and Binah which govern the reason—Daath. This faculty can be thrown downwards into the Ruach, and thence can radiate into the Nephesch. It consists of seven manifestations answering to the Hexagram, and is like the Soul of the Microprosopus or the Elohim of the human Tetragrammaton. Therefore in the head, which is its natural and chief seat, are formed the seven apertures of the head. This is the Spiritual Consciousness *as* distinct from the human consciousness. It is manifested in 7 as just said or in 8 if *Daath* be included. The Father is the Sun (Chokmah). The Mother is the Moon (Binah). The Wind beareth it in his bosom (Ruach). Its Nurse is the Earth (Nephesch). The power is manifested when it can be vibrated through the Earth.

Of the Temple in Reference to the Sephiroth

First Part

The 'Kemple as arranged in the first part of the 1=10 Grade of Zelator (see diagram on next page) shows the Tree of Life in Malkuth, a complete Tree of Assiah. The three paths of *Shin*, *Tau*, and *Qoph*, as illustrated by Hebrew letters above the dais, show the connection to Malkuth from the greater Tree. Kether is shown for the first time in the Outer Order rituals, and it relates to Kether of Assiah, the Higher Self. This is seen by the candidate, in his or her limited comprehension. Kether must be attained and linked to the physical body at the eastern part of the Altar, and under the guardianship of Sandalphon. The Stations relating to the Tree are as follows:

Officers on the Dais Station of the Tree God-form

Cancellarius	Ain Soph Aur	Thoth
Praemonstrator	Ain Soph	Isis
Imperator	Ain	Nephtys
Hierophant	Kether	Osiris

I have amended the original Whare Ra ritual to include these four officers.*

The elemental king is also the main coordinator for the tablet.

*It has been assumed that these officers do not appear in the elemental grade rituals, but in fact they can. In the old Golden Dawn, the placing of these officers was optional. In the Stella Matutina, these officers were generally included, on the dais, or else their places were taken by the Wardens of the Temple. If they are not present, the Hierophant has to take the responsibility of performing all their functions. This is almost impossible, as the Stella Matutina found out in later years. Though their positions were generally not marked on the temple diagrams for the 1=10 ritual, it was always understood that they would be present. It is in areas like this that the experience of members of the Stella Matutina, in working the rituals, discovered the weak areas of early Golden Dawn ritual and compensated for them. You will note that a complete Tree of Life is on the floor, while the Supernals are duplicated on the dais. The Chiefs or Wardens on the dais reflect the power of the Tree on the floor. If only the Hierophant is used, then he will do similar work, but it will be directly through Kether.



1=10 Temple Setup, Part I, View from East



Beginning of Part I



Invocation Before Earth Tablet



Circumambulation



Candidate Before Path of Evil

Mar-White swayed down the
Barber of the West. This political candidate the energy of Mar,
preventing it from disrupting the economy. She has the best



Candidate Before Path of Good



Candidate Between Path of Good and Evil



1=10 Temple Setup, Part II

He directs what forces go where. During the ceremony, through the temple officers, the elemental king enters the etheric aura of the candidate through the chakra centers. His energies are linked to the diversification factor. He raises the vibrational pitch of the candidate's aura so that it corresponds to the elemental plane related to the Earth element.

The three sets of knocks, totalling 10 in each set, relate to the number of the Sephirah Malkuth. Here the Sephirah is invoked, whereas previously the Earth Element was invoked. This *is a* good example of the multifaceted principle of Golden Dawn ritual.

God-Forms of the 1=10 Grade

Behind the stations of the Chiefs are the god-forms of the Three Paths.

Mau—Mau stands in front of the letter *Shin* and above the Banner of the West. This position curtails the energy of Mau, preventing it from disrupting the ceremony. She has the head of a cat, in green, with twin red feathers above a yellow solar disk. She wears a red robe. Her arm bands are red, as are the ankh and lotus wand which she holds. Mau is shown on page 34.

Mut—This god-form stands in front of the letter *Thu* and directly above the throne of the Hierophant. She wears a black vulture's crown with the red and white crown of the North above it. Her nemyss is black-and-white striped. Her dress is black, and her skin is white. Her lotus wand is red and entwined with a green serpent. Mut is shown on page 35.

Opaut—This god-form stands in front of the letter *Qoph*. The wolf's head is predominantly crimson with a green waist cloth, armbands, eyes, and ankh. His skin is a light translucent green. He holds a red ankh and lotus wand. Opaut is shown on page 36.

Isis—The station of Isis is on the place of the Praemonstrator on the dais. She has a blue headdress on which the emblem of the throne is mounted. Her nemyss is of blue and orange stripes. Her skin is golden yellow and her lower dress is blue with orange straps—the same color as her armbands. She holds



Mau



Mut

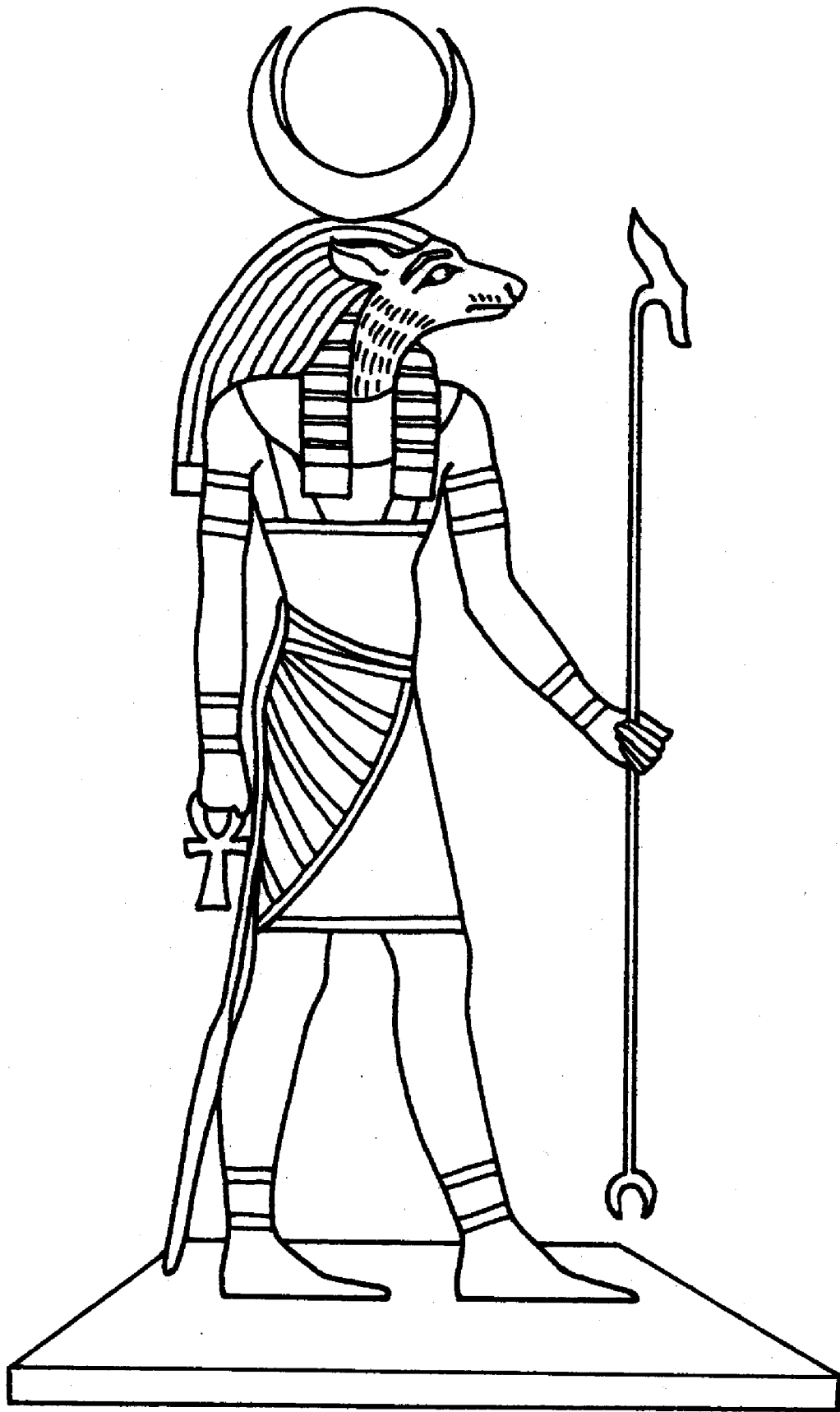

Opat



Isis

a green lotus and a red ankh. Isis is shown on page 37.

Nephtys—This god-form is on the station of the Emperor. She has a lunar-shaped crown over her black vulture headdress. Her nemyss is black-and-white striped with a necklace of the same color. Her skirt is black with white straps. Her armbands are black-and-white striped. She holds a green lotus and red ankh. Her skin is golden yellow. Nephtys is shown on page 39.

Thoth—This God-Form is on the station of the Cancellarius. The color of his ibis head is yellow and mauve. His skin is yellow, while his waistcloth and armbands are mauve. In his left hand he holds a white feather and in the right a white scroll. Thoth is shown on page 40.

Osiris—This god-form is on the station of the Hierophant. He wears a white conical cap with the blue feathers of Maat on each side. His skin is green, and he has a black beard. His body wrap is white, his necklace made up of the elemental colors. He holds a red scourge and a red ankh. Osiris is shown on page 41.

Aroueris—This god-form sits on the throne of the Past Hierophant. His cap is yellow with a mauve surround and blue feather. His skin is green, and he has a yellow waistcloth and armbands. He hold a blue wand and ankh. Aroueris is shown on page 42.

Horus--Horus retains the same position he had in the Neophyte grade, East of the Altar. His face and body are translucent emerald green. He has blue eyes. A curl of blue hair, denoting youth, comes round his face on the right side. He wears the red-and-white double crown. His collar and waist cloth are yellow and blue. His lion's-tail girdle is mauve. His lotus has leaves alternately blue and yellow. Horus is shown on page 43.

Nekebit--Nekebit is a figure of light, translucent green with green eyes. Her headdress is shaped like that of Osiris, mainly white with two plumes of gold. Her dress is red with dark green bands. Her staff is black and entwined with a gold Uraeus symbol entwined around it. The collar around her neck is gold, red, and dark blue. She is in the station of the White Pillar. Nekebit is shown on page 44.

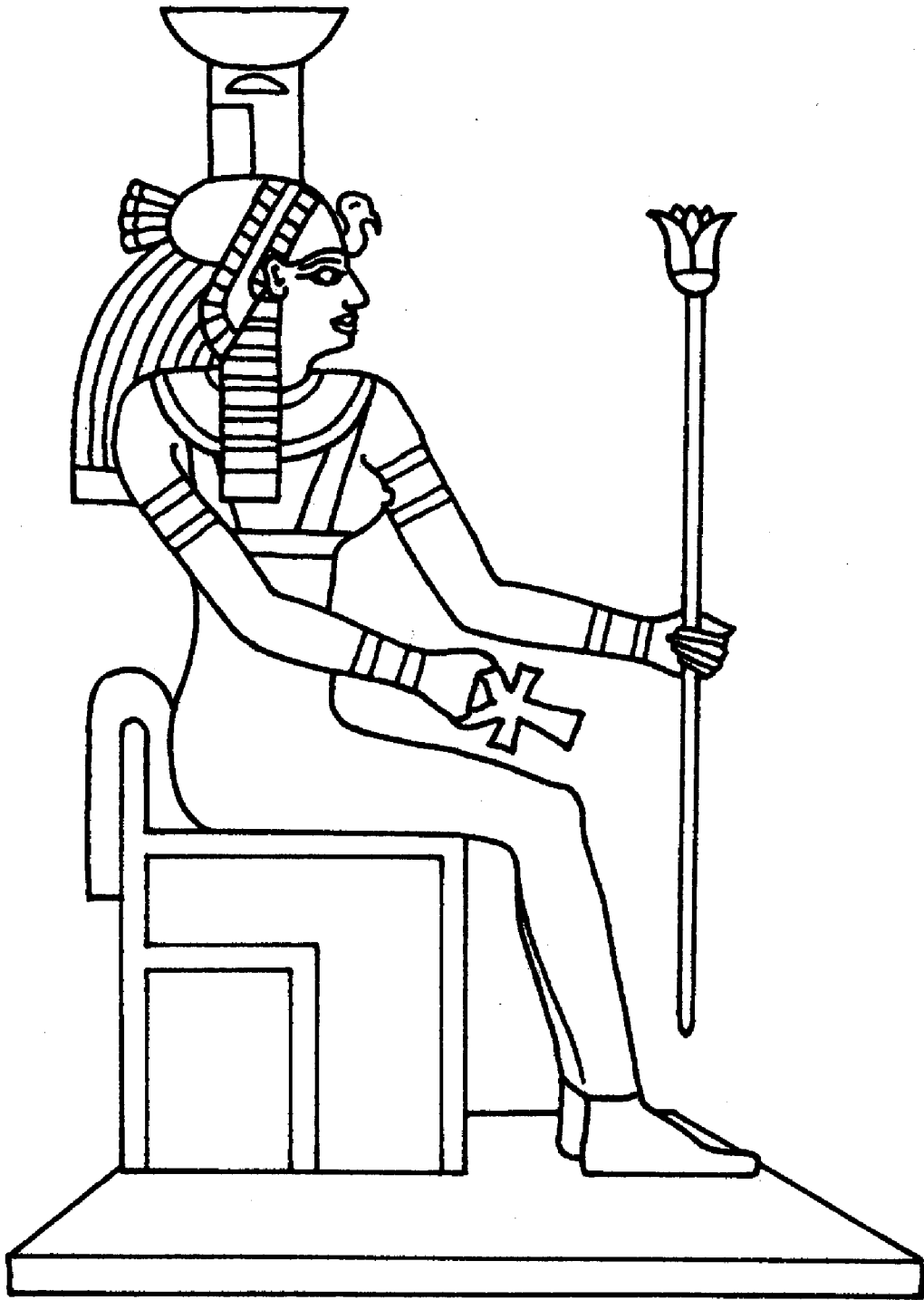

Nephthys

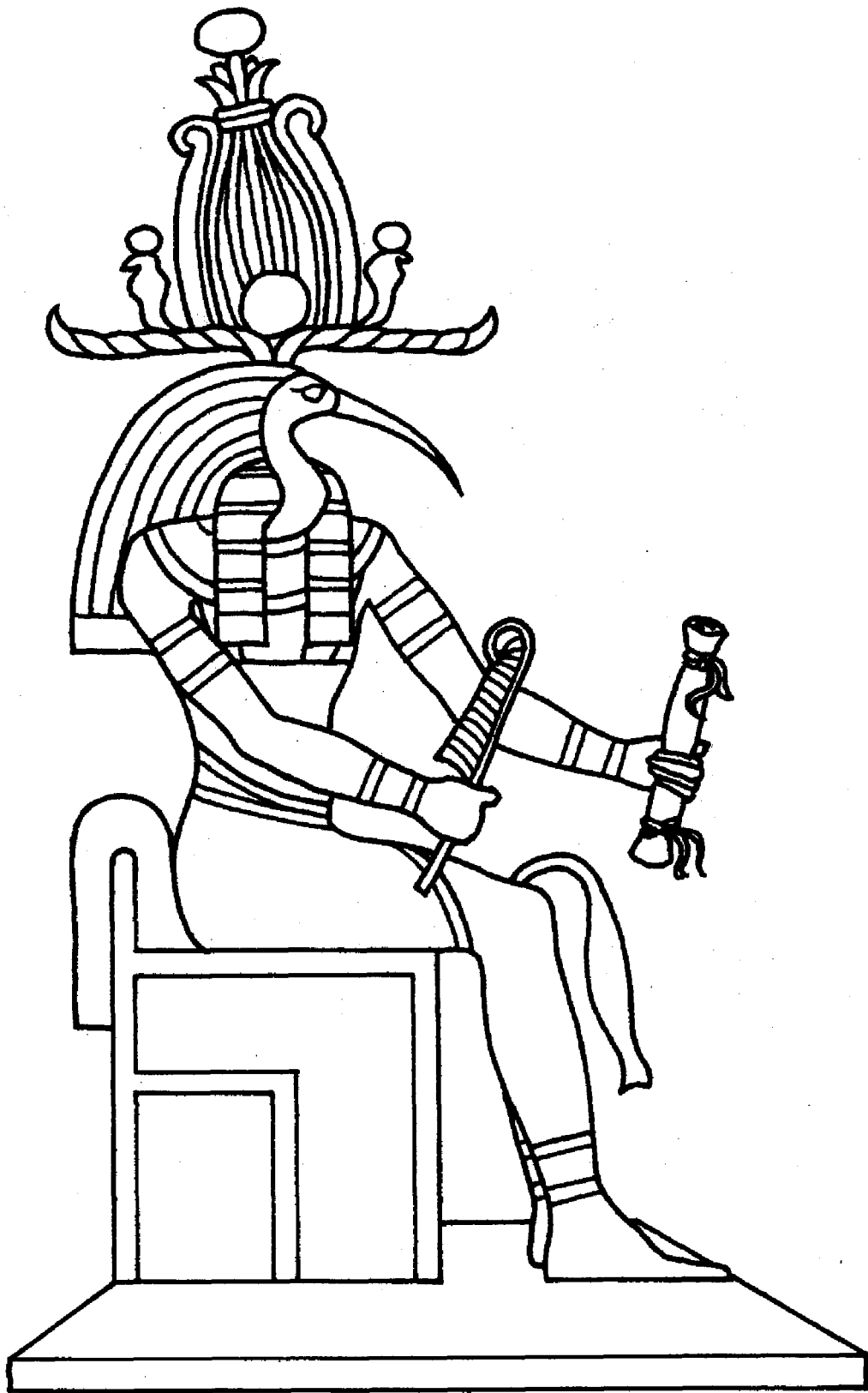

Thoth



Osiris

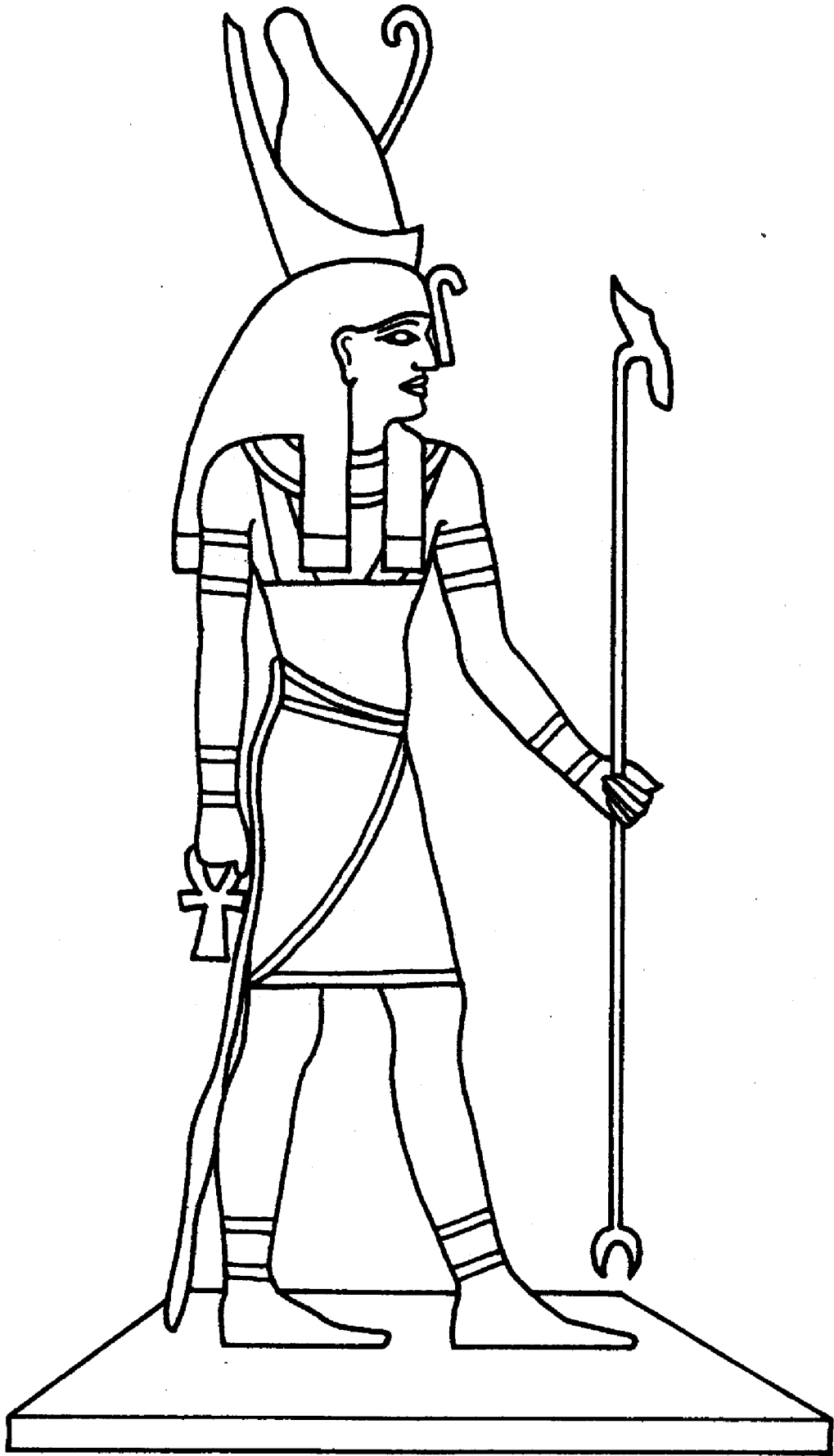

Aroueris



Horus



Nekebit

Uatchet—This god-form has skin of translucent gold; she wears the black crown of the North with a green feather. Her eyes are black, and her dress is violet with gold bands. She has a black staff with a lotus at the end, which is entwined with a green serpent. Uatchet is shown on page 46.

Het-Hert—This Goddess stands at the Western entrance to the Immeasurable Region. She wears green and purple peacock feathers emitting from her pillared crown. Her skin is blackish red; her nemyss is green and red—the same as her collar. Her dress is dark green. She has dark eyes and carries a red ankh and black wand. Het-Hert (or Hathor) is shown on page 47

Kerub of Air: Henkhisesui—This Kerub is formed on the farthest eastern boundary. She has the face of a young girl with translucent gold skin and a mauve dress. Her large, spreading wings are a mauve mixture with flashes of golden yellow. Henkhisesui is shown on page 48.

Kerub of Fire: Shebui—This Kerub is formed on the farthest reaches of the southern boundary. He has the red head of a lion, large red wings that flash with emerald, and a green tunic. His skin is translucent red. Shebui is shown on page 49.

Kerub of Water: **Hutchaiui**—He has the face of an eagle, and is light blue in coloring. His large spreading wings are blue with flashes of orange. He wears an orange tunic. Hutchaiui is shown on page 50.

Kerub of Earth: **Qebui**—**He** has the face and form of a bull. He has heavy, darkening wings, of black, green, red, and white. Qebui is shown on page 51.

Ameshet—The man-faced Child of Horus is in the Northeast. He has a blue nemyss banded with red, blue, and black. His face is red; he has a black ceremonial beard. Round the shoulders of his white mummy shape are bands of red, blue, and black, three times repeated. Ameshet is shown on page 52.

Tmoomathph—The jackal-faced Child of Horus is in the Southeast. He has a black face with yellow linings to his pointed ears. He **wears a blue nemyss with borders of black, yellow, and**

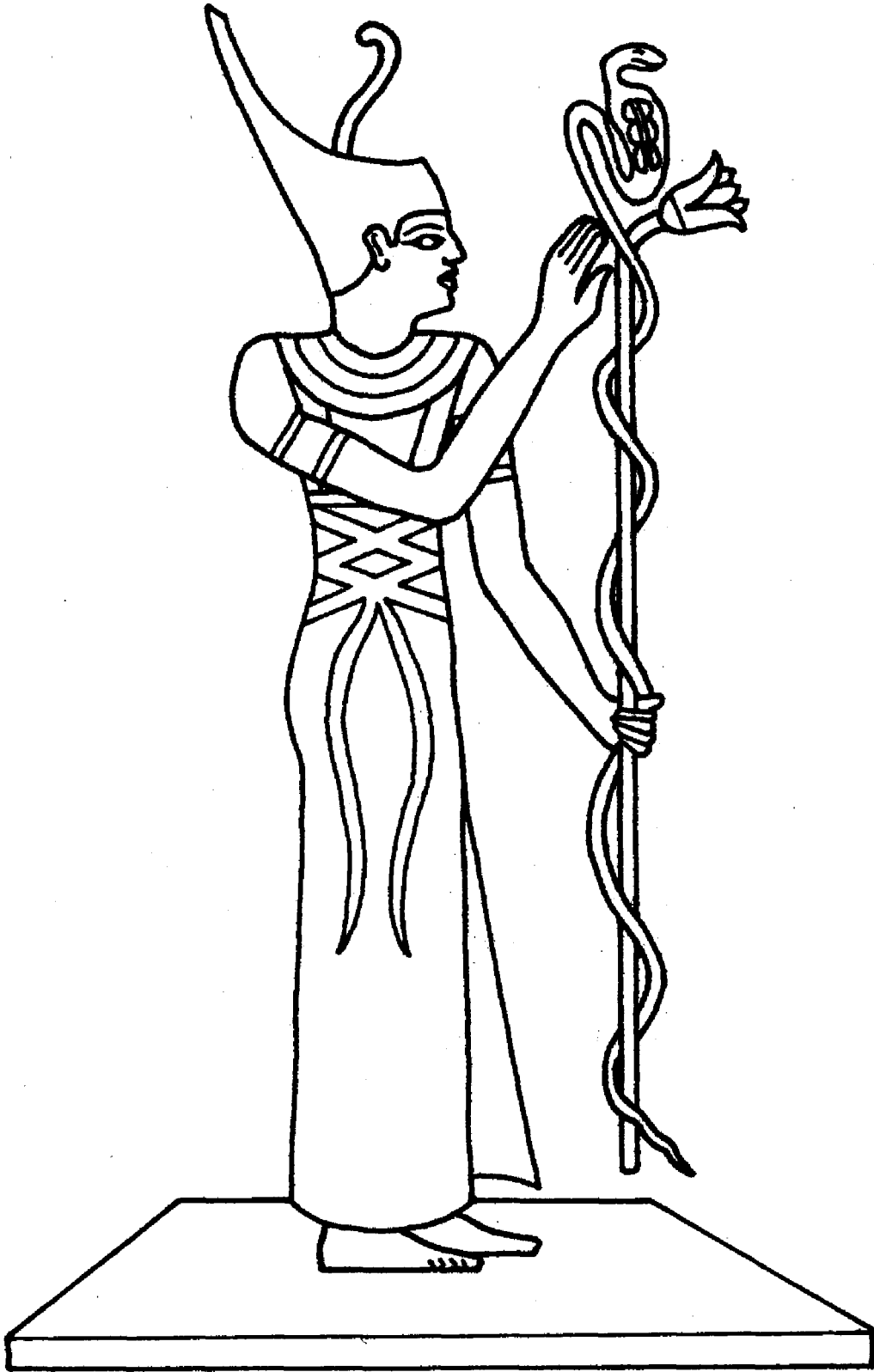

Uatchet



Het-Hert



Kerub of Air: Henkhesesui



Kerub of Fire: Shebui

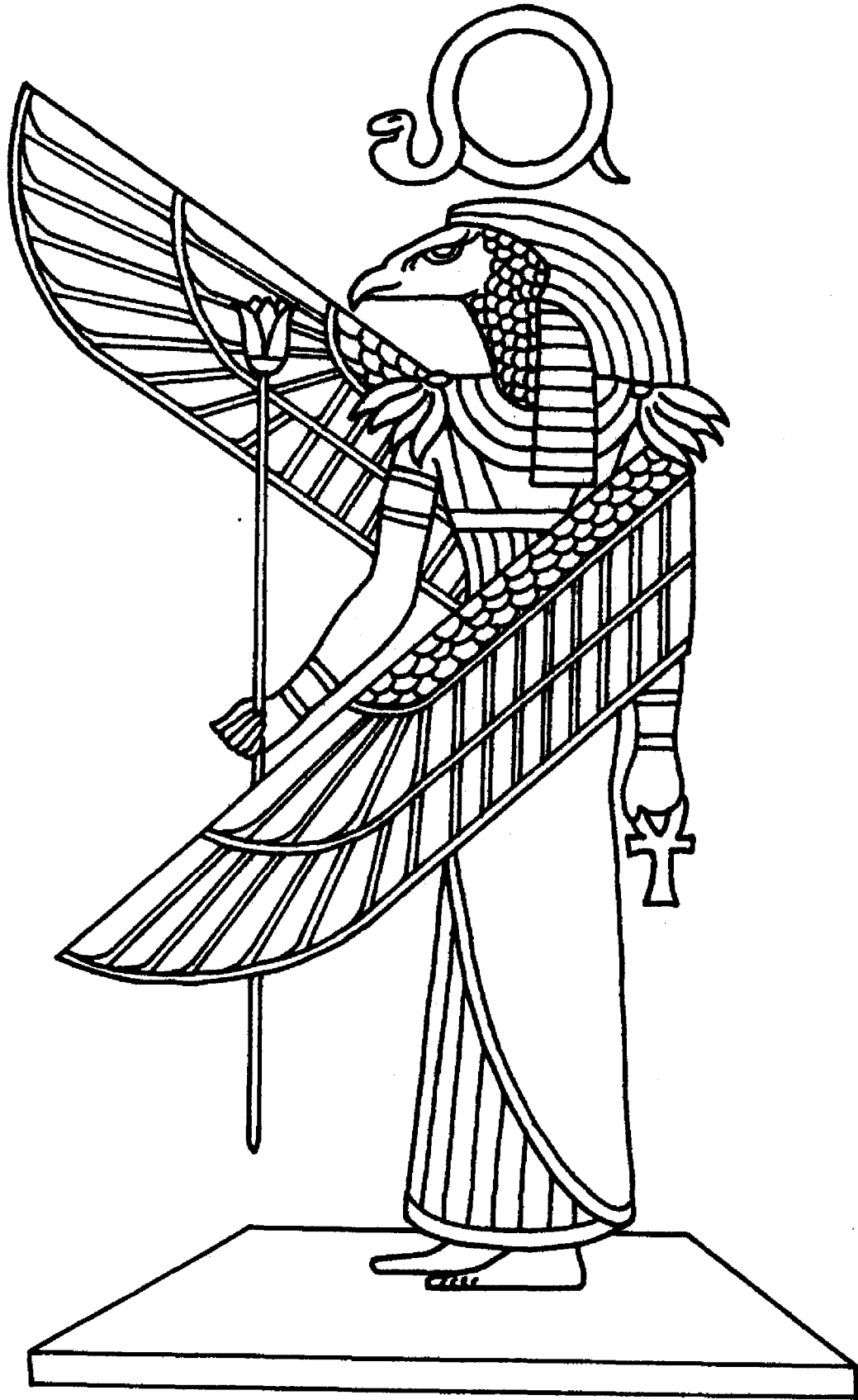

Kerub of Water: Huchaiui



Kerub of Earth: Qebui

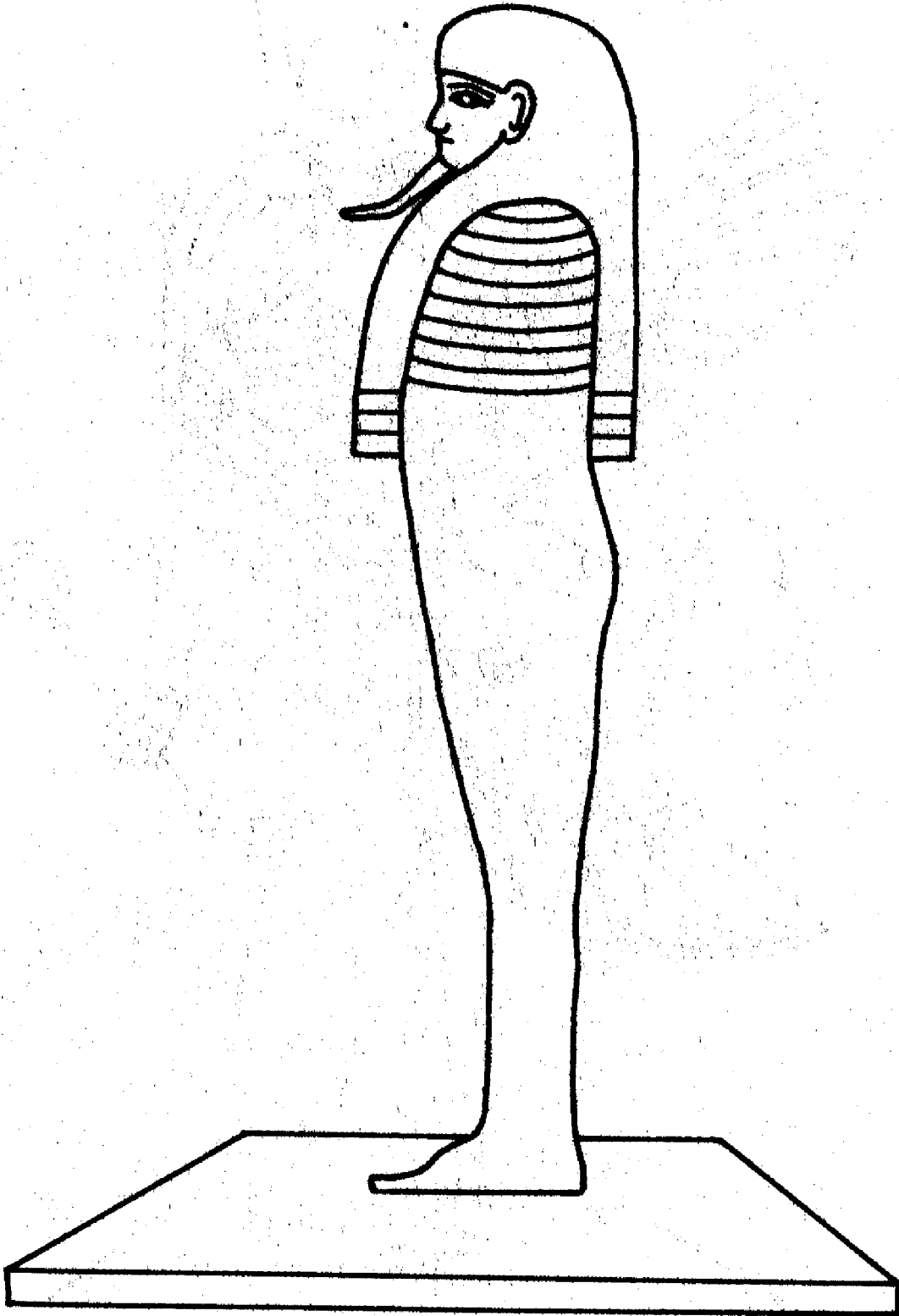

Ameshet

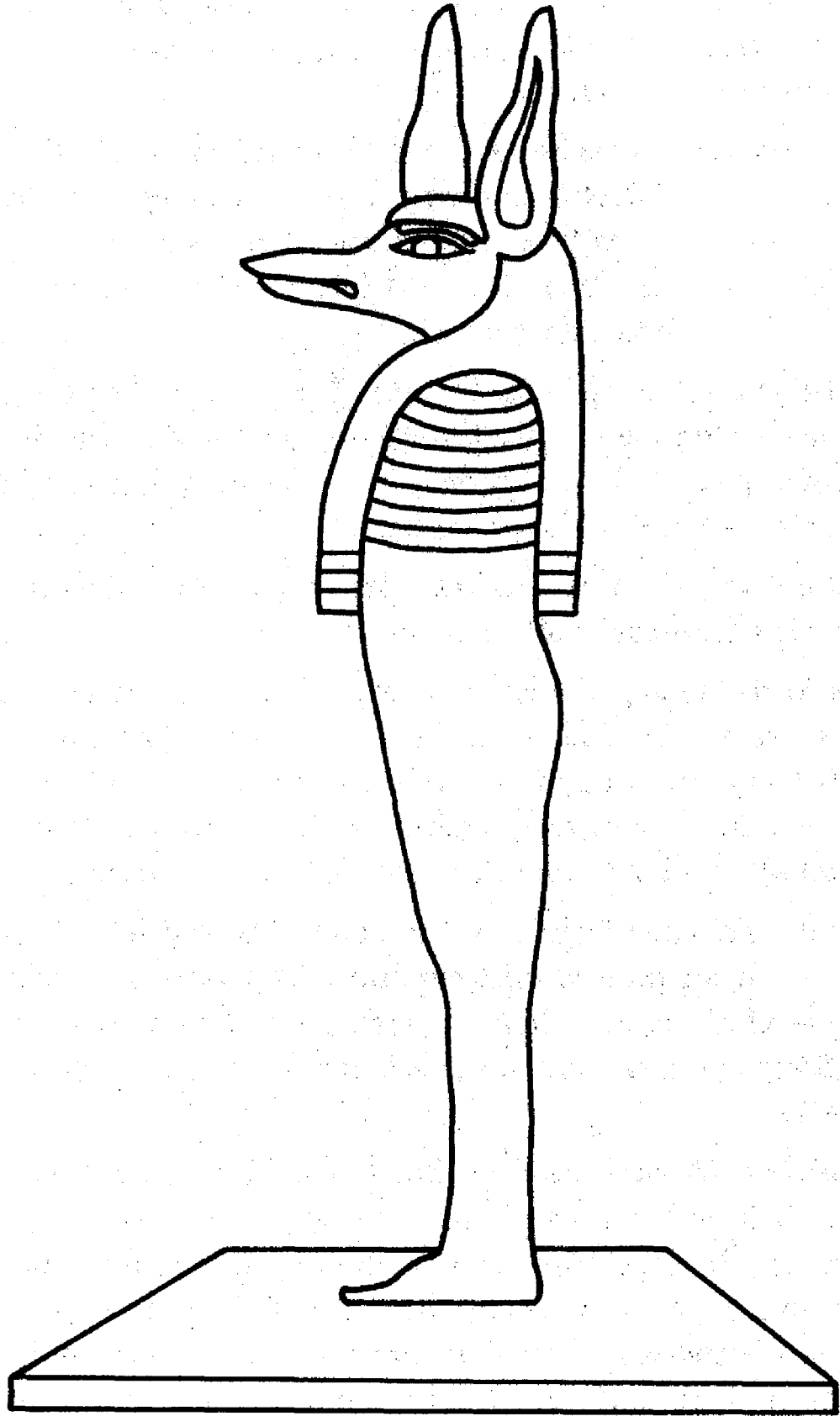

Thoomathph

blue, the same colors appearing threefold at his shoulders. He has a white mummy shape and stands on blue, yellow, and black with a border of green, yellow, and mauve. Tmoomathph is shown on page 53.

Kabexnuv—This hawk-faced Child of Horus is in the Northwest. He has a black and tawny face and a nemyss of black bordered with red, yellow, and black. The same colors appear threefold at his shoulders. He has a white mummy shape. Kabexnuv is shown on page 55.

Ahephi—This ape-faced Child of Horus is in the Southwest. He has a blue nemyss with red, blue, and yellow bands. These colors appear on his shoulders in the same order. His face is a red color. Ahephi is shown on page 56.

The Forty-two Assessors—These god-forms are placed just above the Immeasurable Region.

Tefnut—This god-form is in the place of the Dadouchos. She has a green disk and two gold serpents surmounting a golden lion's head. Her body is translucent yellow; his dress is green with a mauve collar and armbands. She holds a staff with a lily mounted on top and an ankh. Tefnut is shown on page 57.

Shu—This god-form is in the place of Stolistes. He is blue in color with an orange nemyss and translucent blue skin. His orange clothing is trimmed with gold. The plume from his headdress is dark blue, and he has blue eyes. Shu is shown on page 58.

Anubis—Anubis has the head of a black jackal, with very alert, pointed ears—well pricked up. His nemyss is purple banded with white. He wears a collar of yellow and purple bands. His tunic is yellow, flecked with tufts of black hair. His body is red. His waist cloth is yellow striped with purple, and from it hangs a lion's tail. His ornaments are purple and gold; his phoenix wand and ankh are blue. Anubis is shown on page 59.

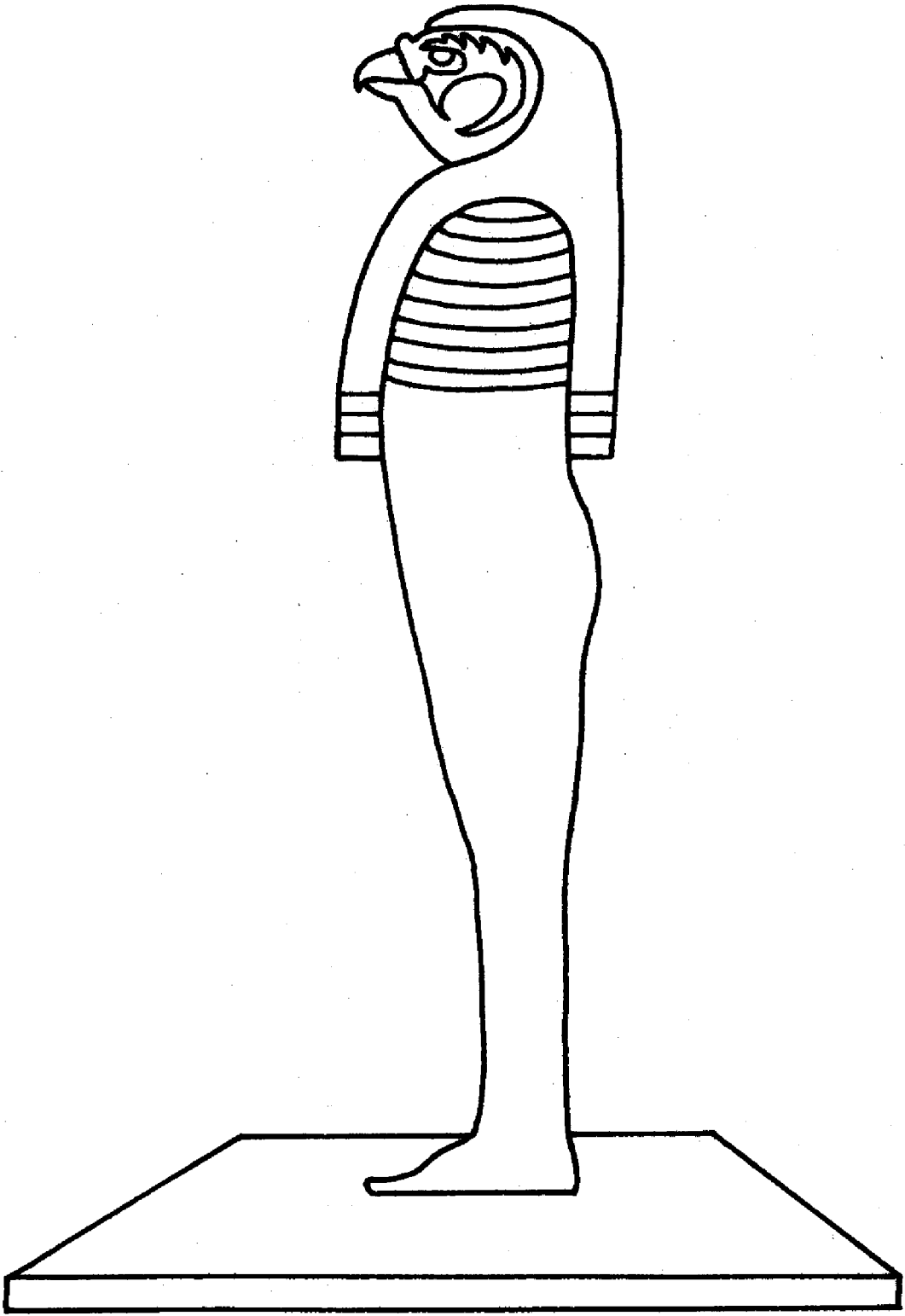

Kabexnuw

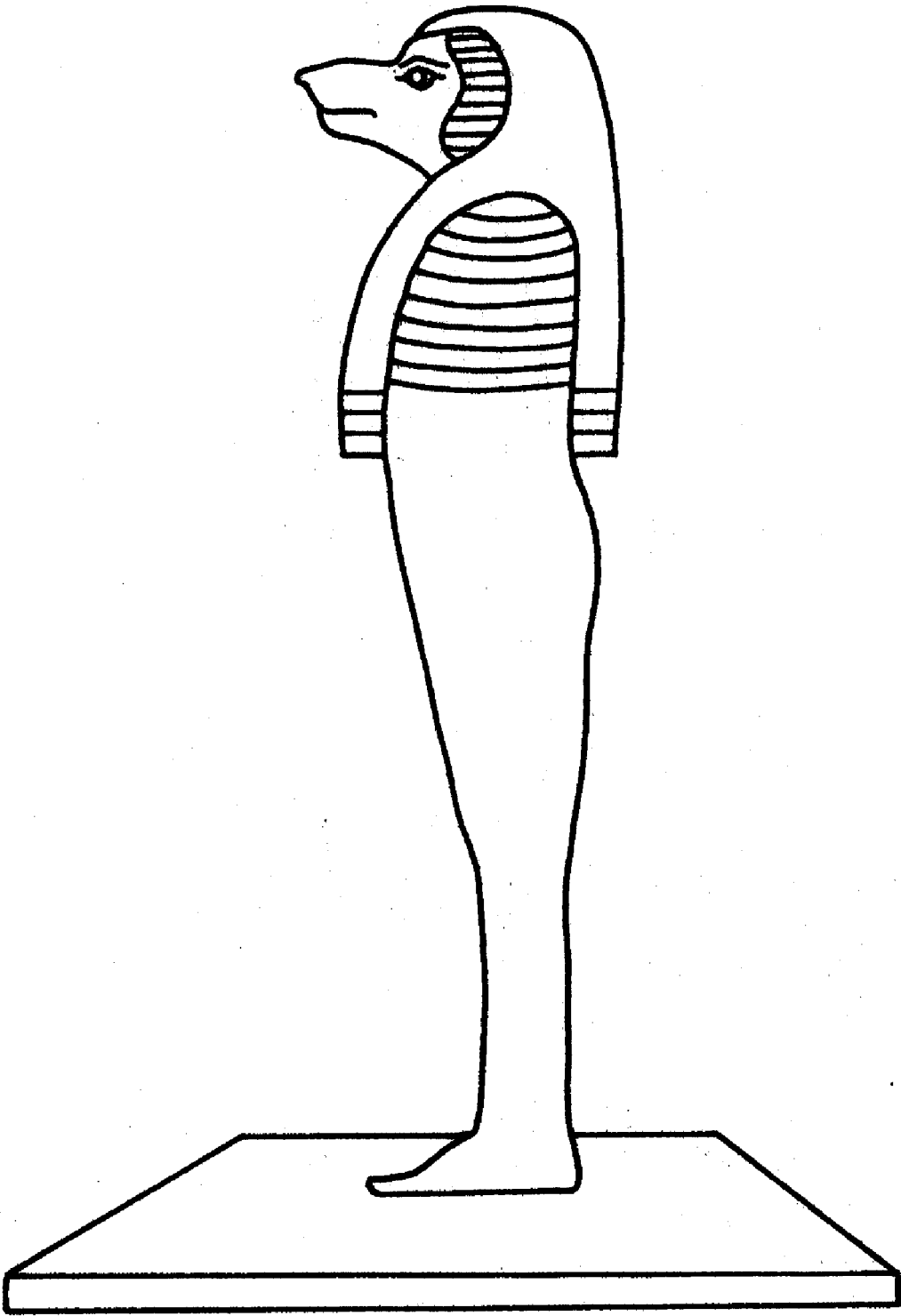

Ahephi

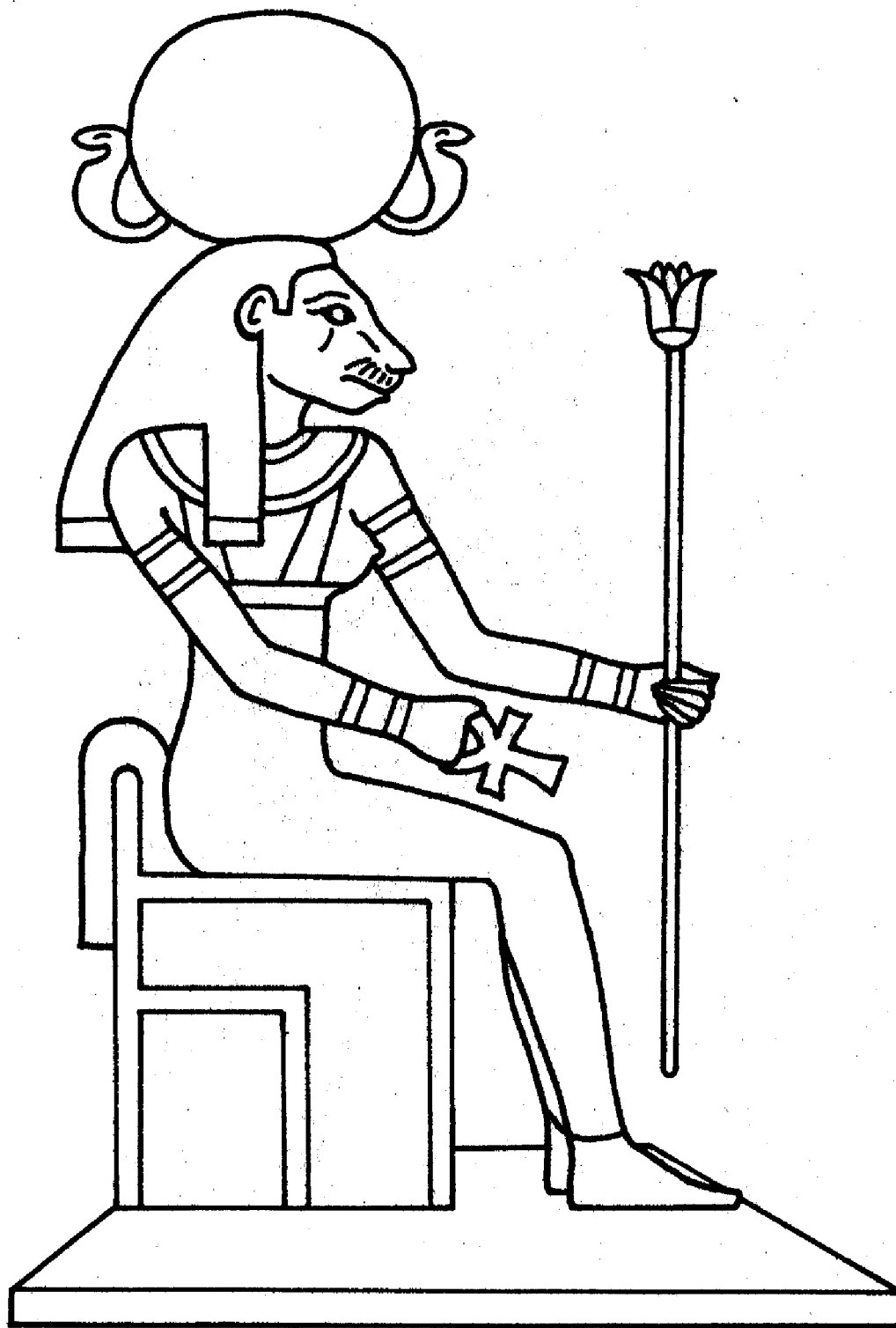

Tefnut

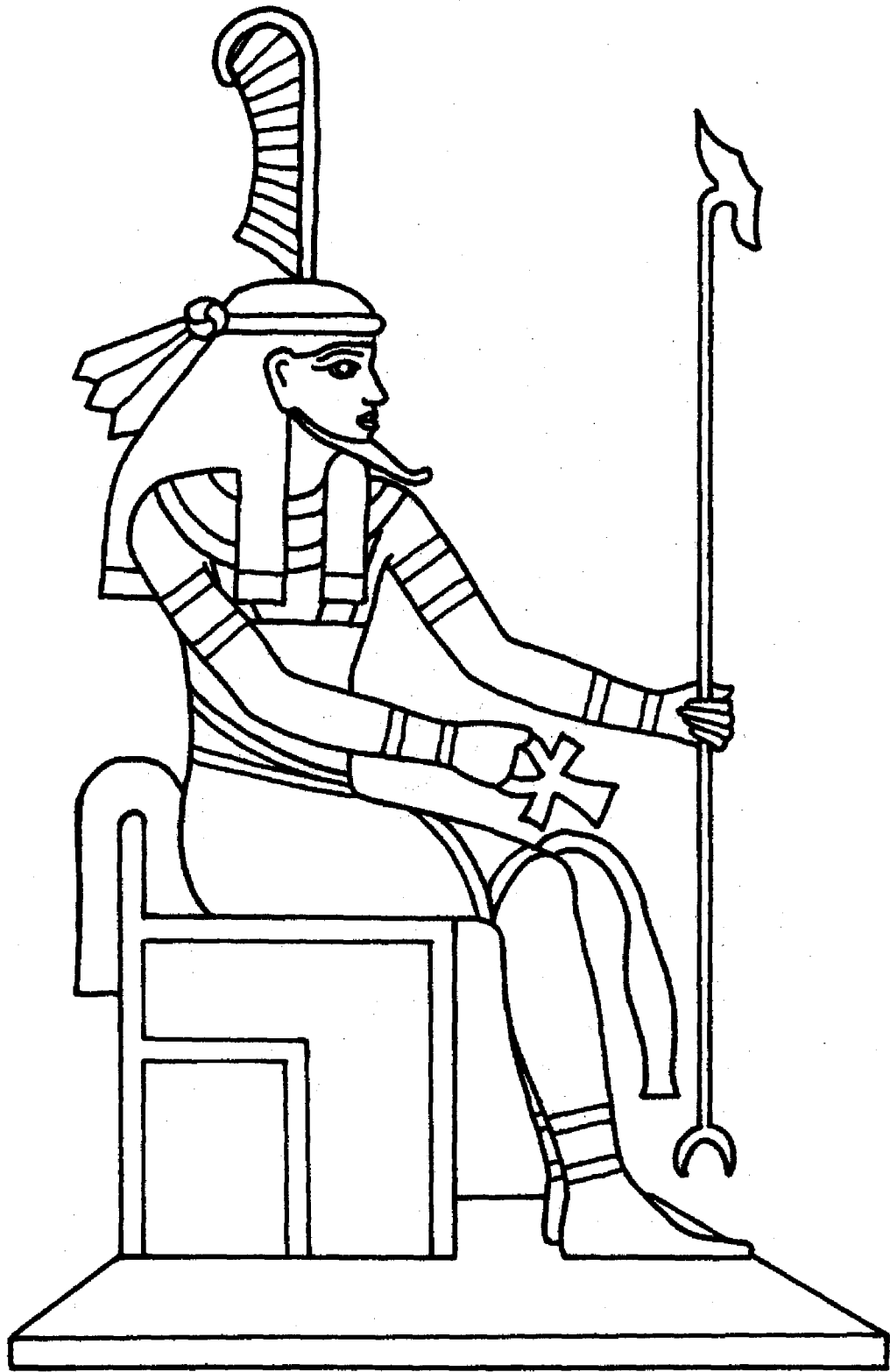

Shu

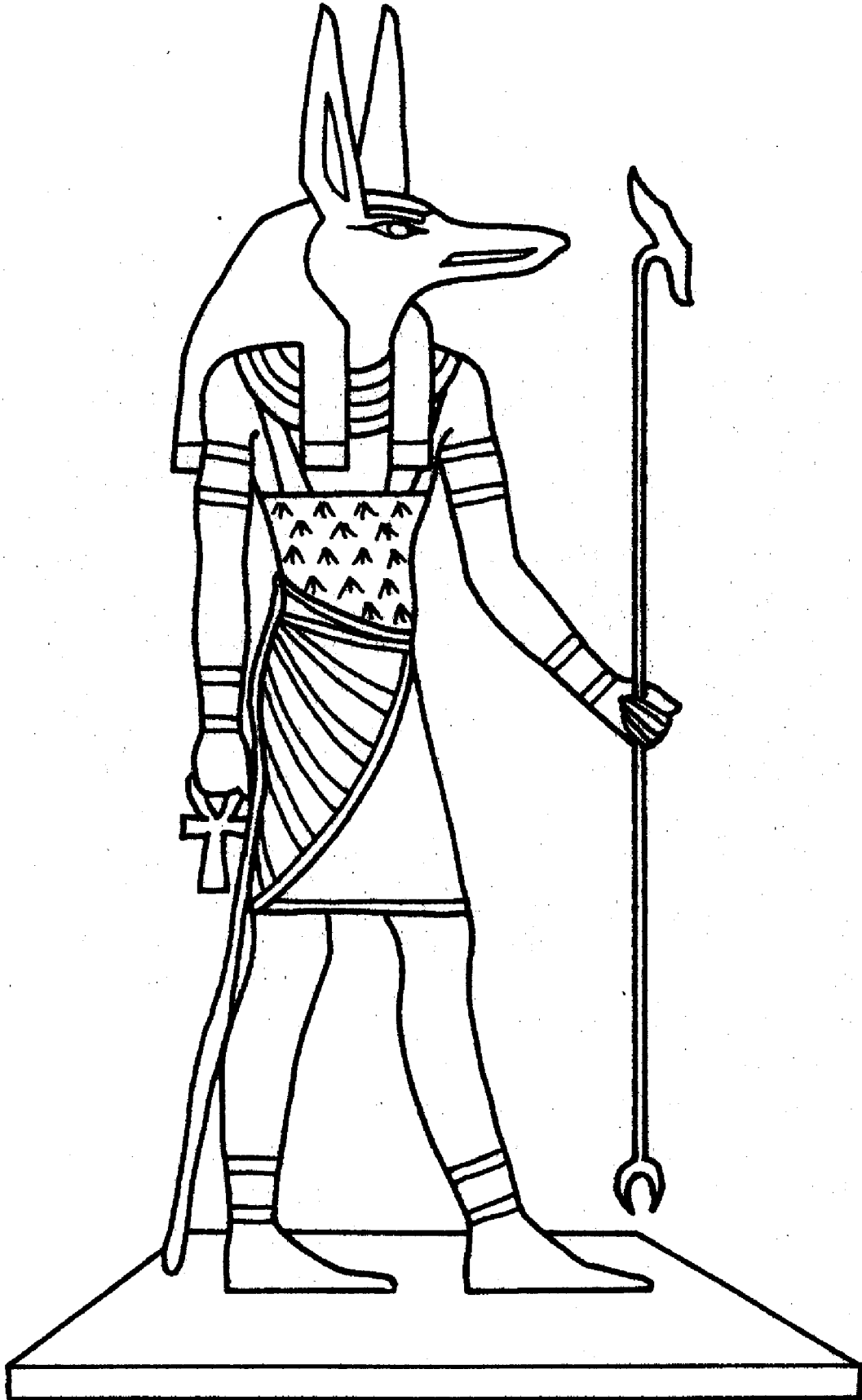

Anubis

Symbolism of the Temple

The three Hebrew letters that hang above the dais represent the untrodden paths of the candidate. They make up the Hebrew word *qesheth*, a bow. This is said to reflect the rainbow symbol over the dais. The rainbow symbolized by these letters is, by analogy, a bridge between man's higher and lower natures. These letters, being placed above the Chiefs, signify the power of the Second Order manifesting in the First or Outer Order. This represents Higher Knowledge given to those who seek it.

The Altar symbolism shows a cross within a triangle, which shows spirit in matter (a reflection of the topic as discussed in the previous paragraph)—a symbol also for mankind. This is also a symbol of both rejection and knowledge attained. The inference of this symbol is that knowledge can be attained—if the cause of a person's ignorance can be discovered through the teachings of the Order. The symbolism on the Altar is the same as that on the Banner of the West, which is explained in the Zelator Grade: the white triangle refers to the three paths connecting Malkuth with the other Sephiroth, while the red cross is the Hidden Knowledge of the divine name which is to be obtained through their aid. "The cross and triangle together represent Life and Light."

Within the Golden Dawn cipher manuscripts, the red cross is also referred to as the Cross of the Kerubim. This is because of the placing of the Kerubim at the cardinal points, forming a cross. The red cross becomes a cross in the microcosm because of this fact. The red lamp, situated on the Altar, shows the Hidden Knowledge. Its position at the apex of the white triangle shows that this must be attained before the red cross can enter the triangle of Spirit. It becomes the symbolic goal of the candidate.

The symbolism of the Flaming Sword, placed on the western side of the Altar, relates to the paths of both ascent and descent: descent of the divine knowledge into mankind, represented by the candidate, and mankind's aspirations to climb the "Path of Higher Learning" through kavanah—devotion. The Black and White Pillars represent the stations of Chesed and Geburah.

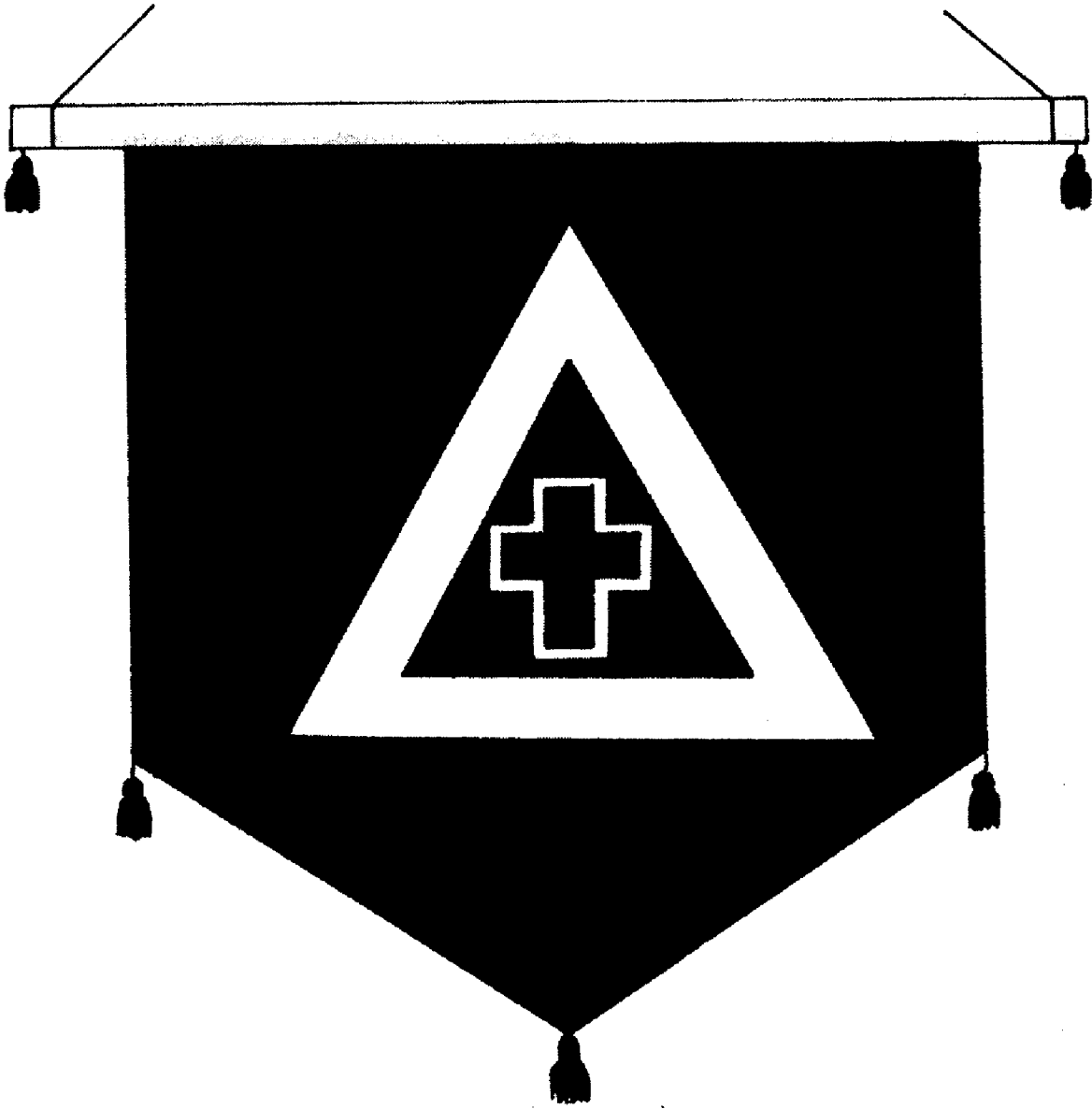

Banner of the West

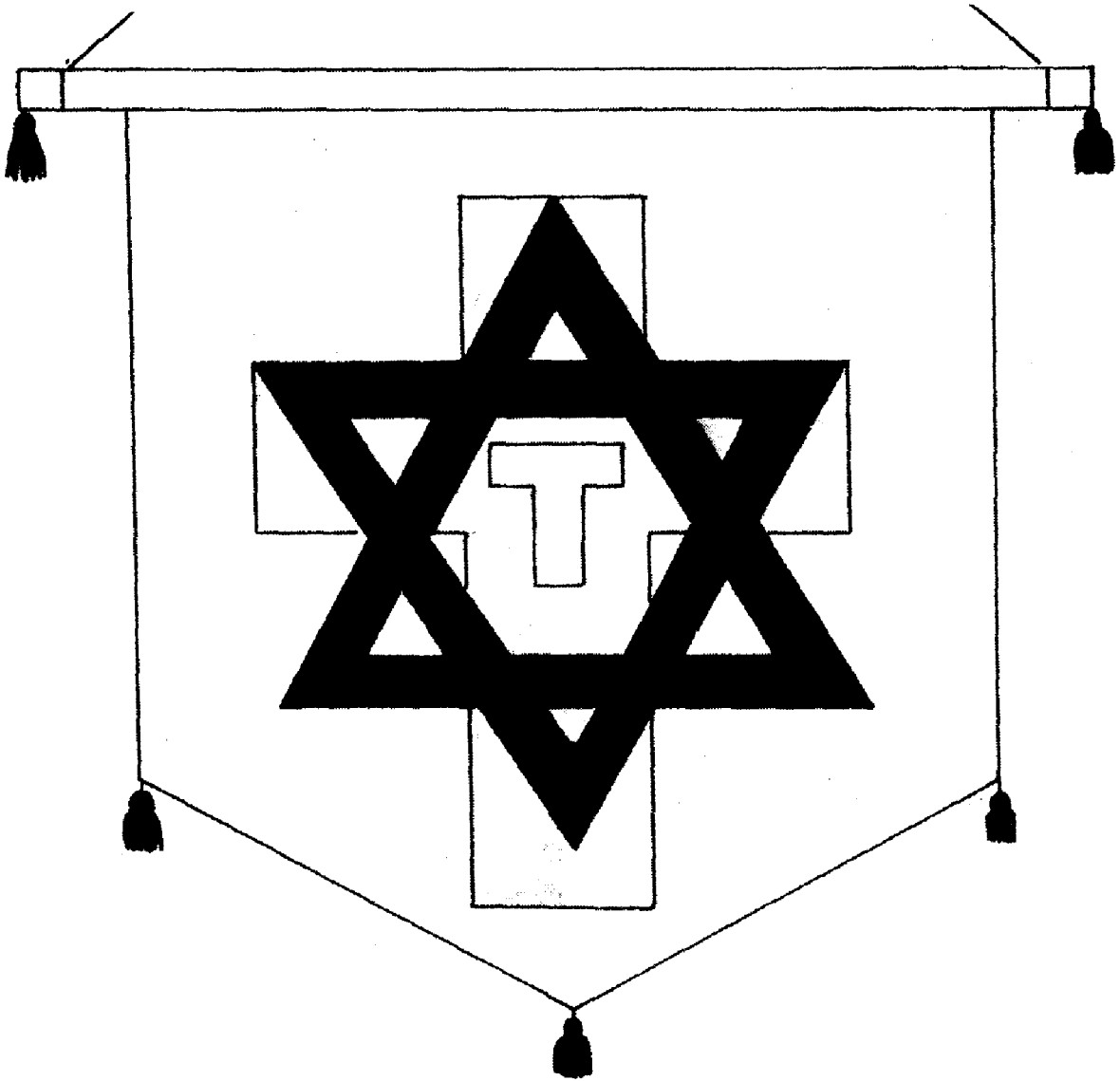

Banner of the East

Placed in the position below the Altar, they create the void between light and darkness called, "the Immeasurable Region," which the Higher Self of the candidate must advance through.

The unveiled Enochian Tablet in the North represents the forces of the Earth element and the hierarchies that the candidate must be exposed to during the ritual. These forces are the ones that control the Earth element. The salt, on the side of the Altar directly in front of the Tablet, shows the tangible form that the Tablet represents. The Earth Tablet is the only one of the four present that is unveiled. The others are covered with cloths that have the colors of their respective elements.

The lamp in front of the Earth Tablet relates to the "Ever Burning Lamps" of the Rosicrucian mysteries, which suggest that, once alight, the lamps were never extinguished until an intruder entered the tomb. In this ceremony, the lamp relates to the ever-present offering to the Earth Element. The following Egyptian invocation was given to me by Taylor to say before the Earth Tablet before the start of the ritual:

Souls of That, that he that knoweth their name shall be with them. This Great God will give him fields, the situation of which shall be in the country of Ur-Ness. He shall stand up with the Gods who stand up, and he shall follow after this Great God. He shall trample the eater of the Ass, and after the division of the Unoccupied Land has been made, he shall eat bread in the Boat of the Earth.

The Banners of the East and West are both placed on the dais. This time, instead of guarding against the Qlipoth, the Banner of the West prevents the energies of the Paths from entering into the ceremony.

Preparation Of the Candidate

1. Obtain an astrological natal chart of the birth time, or approximate birth time, of the candidate.

2. Prepare an electional chart and marry with the natal chart to decide an appropriate date and time for the ritual.

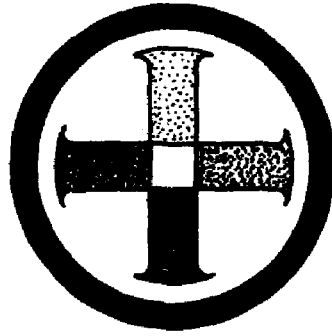

b	O	a	Z	a	R	o	p	h	a	R	a
u v	N	n	a	x	o	P	S	o	n	d	n
a	i	g	r	a	n	o	a o	m	a	g	g
o	r	p	m	n	i	n	g	b	e	a	l
r	s	O	n	i	z	i	r	l	e	m	u
i	z	i	n	r	C	z	i	a	M	h	l
M	O	r	d	i	a	l	h	C	t	G	a
R o	C O	a c	n a	c m	h c	i h	i b	a t	s a	o s	m o
A	r	b	i	z	m	i	i l	l	p	i	z
O	p	a	n	a	l B	a	m	S	m	a	T L
d	O	l	o	P F	l	n	i	a	n	b	a
r	x	p	a	o	c	s	i	z	i	x	p
a	x	t	i	r	V	a	s	t	r	i	m

Earth Tablet (Watchtower of the North)

3. Once the time has been established, (which is never on the dark side of the Moon's influence), the candidate is to fast 12 hours, taking nothing except water.

4. Before the ceremony, the candidate should bathe in herbs of the Composite family (which are too numerous to list).

5. For meditation purposes, the candidate is given a small handful of rock-salt crystals some 30 minutes before the ceremony. The candidate is to extend his/her aura to link with the nature of the salt. The candidate is then given a yellow square on a card. S/he should meditate on this card for about 15 minutes before the start of the ceremony.

Preparation of the Hall

1. The temple props are put into place by the Dadouchos, about two hours before the ceremony.

2. The Hierophant enters the Hall, once the Dadouchos has left, and performs the Banishing Ritual of the Pentagram with the Sword of the Hieres (which should be in its correct station).

3. The Hierophant creates the god-forms of the Visible Stations and the Invisible Stations. He also invokes the power of Earth through the Egyptian invocation.

4. Once all this has been completed, the Chiefs on the dais should enter the temple and create their respective god-forms. If they cannot be present, then it is the Hierophant's duty to create these god-forms.

5. The remaining officers should enter the hall (on a cue from the Hierophant).

6. The candle-lighting ceremony begins when all officers are present.

7. When the candles and lamps are lit in the temple, the officers should assume their respective god-forms, previously created by the Hierophant.

Symbolism of the Opening

The Hiererus knocks to ask permission of the Hierophant to advance the candidate to the elemental grades. This knock is done with the base of the Sword, on the edge of the chair, and becomes a bridge for the first link with the Altar.*

With the opening speech of the Hierophant, he sends forth

***The Hiererus, and not the Hierophant, knocks here as a form of petition for the Hierophant to open up the portal to the elemental grades. This is allied to the Hiererus, acting on behalf of the candidate, to ask permission for the elemental grades to be opened up to the seeker of the Light. It is very important that the Hiererus does this. Taylor put it to us this way: "You do not open the door unless someone seeks admission."**

The Office of Sentinel is not dropped after the Neophyte ceremony. The original Golden Dawn copies, and those from Whare Ra Temple, clearly state that this officer is present. The Hiererus holds his sword upright for the entire ceremony. It is only transferred to his right hand when standing in front of the Tablet of Earth, with the edge of the sword turned slightly outward. The cutting edge faces outward, so that no negative influence can penetrate the area guarded by the Hiererus. The Hiererus does not put down the sword, but gives the grade *sign* with his free right hand. No sign is ever given from a seated position.

the ray of light through his Ruach to the Altar, then to the station of Kerux, thus activating directly the Kerux's station and Sphere of Sensation.

After this, the Kerux sees that the entrance of the Temple is properly guarded. The Hiereus, commanded by the Hierophant, tests those present to insure that they are of 1=10 grade, or higher. This testing procedure is not really for the officers working in the ceremony, but for those present in the hall, outside the portal watching the ceremony. All those within the hall have to reply to the signs at the order of the Hiereus. When all these signs are done in unison, towards the East, it activates the Spheres of Sensation/auras of the temple officers with the god-forms on the temple floor.*

The next phase of operation is the consecration of the Temple with Water and Fire. At this point, the command of the Hierophant specifically states that the Temple be consecrated with Water first and Fire second, yet the reverse is done. The Water and Fire purification, used in both the Inner and Outer Orders of the Golden Dawn, relates directly back to nature. Both the Christian and Hermetic viewpoint apply here equally: the dissolution of the body, after death, through water, with the rising of the Spirit as fire. In only two rituals of the Golden Dawn are the Water and Fire consecrations reversed: the 1=10 Ceremony and the Consecration of the Vault. We believe both are in error, a point Regardie agreed with.

The firm rule of thumb given to all those in the Inner Order, was that, when consecrating an inanimate object, use Water and then Fire. When consecrating a person, with Earth, the reverse occurs. This should be the only exception. In the Golden Dawn cipher manuscripts (see *Secret Inner Order Rituals of the Golden Dawn*), Fire and then Water is the order given for con-

*When the officers link or submerge themselves in the god-form of the station that they represent, during the candle-lighting ceremony, they only link to the lower levels of that god-form. The Hierophant, during this first show of *signs*, completes this by linking the Supernals of the Sphere of Sensation, through the nemysses of the temple officers. After this, the only other link with the god-forms is to the element of Earth.

secrating the candidate. Mathers suggested that the consecration of the Temple follow the same pattern.

There is a good reason in the 1=10 for the candidate to be purified with Fire first. He or she has just completed the 0=0 grade and is at a level where Fire and salt (representing the Earth Element) are analogous to each other. The next alchemical step is a dissolution to water again. Overall, the author(s) of the Golden Dawn ciphers had a marvelous understanding of nature by injecting the reversal principle.*

However, no matter which way it is viewed, the initial consecration of the Temple should be by Water and then by Fire, with the reverse occurring later in the ceremony for the candidate. In the New Zealand order, we have amended our ritual papers so that the Stolistes purifies first.

Also note that the purification by Water is done from the Pillars, in the order of the ascent of the Lightning Flash, which fits in with the overall picture. This aspect is destroyed when Fire is utilized as the first consecration.

The actual consecration is done slightly above the Stations of the Pillars in order to help clear a path to the Ruach of the ceremony. This helps clear the way for the Breath of Life to be received, not only from the East, but also from the North of the Temple as well.

With the speech of the Hierophant, "Let the Element of this Grade be named that it may be awakened in the spheres of those and in the sphere of the Order," all of the officers present activate the earthly part of their auras, charged in previous rituals by the Enochian Tablets. This is done through visualization of the yellow square that the candidate was asked to meditate on before the ceremony.

Before this is done, the officers do the Adoration to Earth, which gives them their initial connecting link. The kabbalistic

***See *Jung's *Mysterium Coniunctionis** for a full explanation of the Water/Fire combination and discussion of associated alchemical texts. The section on "Personification of Opposites" and the subsections, "Regeneration of Sea Water" and "The Interpretation and Meaning of Salt," are of particular interest, as they present the Christian, Pagan, and Hermetic viewpoints.**

cross unites both the macrocosm and the microcosm of the Earth element, which is necessary before linking to the Tablets because they also have a dual link to Earth.

The movement by the Hierophant, when making the cross with the scepter, is directed slightly upward to the sign of Tau hanging above the dais. All those present have previously travelled this path during their own initiations into the Earth element. The following is from an unpublished Golden Dawn document by Mathers, dated 1897:

Let the Officers formulate the Yellow Cube of Earth around them and let their Sphere of Sensation filleth with every expression of Earth so that their very being is enflamed with Salt of the Earth when the Hierophant linketh with Tau through Cross and Circle . . .

The Hierophant then goes clockwise to the North and places himself in a position approximately six feet in front of the Earth Tablet with the other officers forming behind him (*see figure on next page*).

What occurs here is almost a complete pivot of the temple, with the Kerux remaining at his original station to maintain the stream of Light directed by the Hierophant earlier. This helps stabilize the Altar for its fusion with the direct energy from the Earth Tablet.*

The speech by the Hierophant in front of the Tablet is a method whereby the power of the Earth is formulated like that of human beings (even in the macrocosm) so that it is subjected to the same rules as all living creatures, whether spiritual or otherwise, and can be controlled by the Temple officers (Gen. 1:26-27).

In other words, the Hierophant formulates an archetypal fig-

***In the "Introduction to the Elemental Grades," in Israel Regardie's *The Golden Dawn* (Llewellyn, 6th ed., 1989), it states that the officers form a hexagram in front of the Tablets. Since the Kerux remains in his station, this is not quite the case. The Altar remains *as* the lowest portion of the hexagram and, from this configuration, becomes the recipient of the energy about to be drawn from the Tablets.**

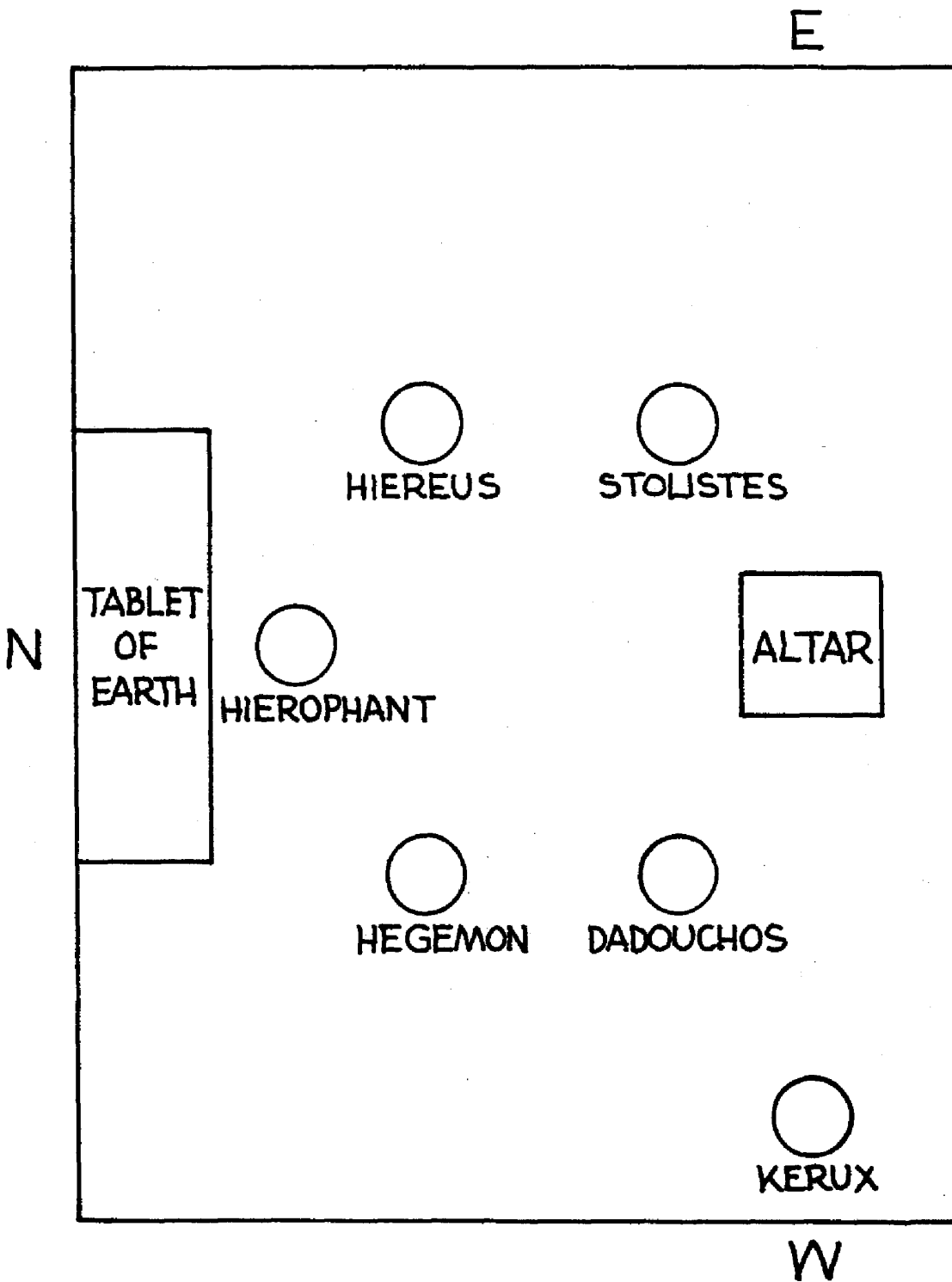

Hierophant and Officers Before Earth Tablet

ure of the archangel Auriel when invoking with Spirit. When directly invoking with the Earth pentagram, this figure can be reduced in size.*

The Hierophant takes the sword of the Hieres. He formulates the *Sign of the Ox*, which represents the Kerub of Earth, who is also invoked in turn. At this juncture, the outermost reaches of the element have been brought under control. An unpublished Golden Dawn paper by Mathers on the subject says:

... Create the Blue Circle in the astral then project it through the Tablet to the very quarter where the Great Arch-angel Auriel standeth. The Pentagrams of Spirit and Earth shall blindeth him with their Brilliance while the force of the Sword will commandeth the Ox, the Great Kerub of Earth who standeth before Auriel though he be somewhat smaller in stature.

This is part of the technique taught in the training of the Hierophant. The Hierophant's scepter acts as a type of long-range blasting rod, used to open, close, and connect to the sword. It is used for invocation and evocation.'

In this elemental ceremony, the invoking pentagram reacts through the tablets, and not at them, as this is its direction. The use of the ox is one example where the Kerub, and not the Tablet, is invoked. In the Opening by Watchtower, one only invokes the Tablet when the Three Holy Names applicable to the Tablet are called as part of making the invoking pentagram. During this opening, the invoking wand is not the Hierophant's Scepter, but the cross, chain, cup, and dagger, which are analogous to the ele-

*Within the old Golden Dawn, and later in the Stella Matutina, both active and passive pentagrams were drawn before the actual invoking elemental pentagram. It is now considered common practice to do either the active or passive pentagram relating to the element concerned rather than the actual elemental invoking pentagram.

fAt this point, we would refer the reader to *Part I: The Neophyte Ritual 0=0*, which described the misuse of the Hierophant's scepter as an invoking instrument during the Opening by Watchtower, and yet it appears to be doing the same thing in the elemental ceremonies, although the Z.1 document warns against such action. This has caused a great deal of confusion.

mental weapons and are Second Order instruments. Book I of the Z-5 series, *The Neophyte Ritual 0=0*, explains further use of the Hierophant's scepter. All further actions in front of the Tablet are passive gestures, such as the cross, to establish an empathy with the ceremony only—not to take the full brunt of its power and inject them into the candidate.

Once the Hegemon's wand is used to make the cross in front of the Tablet, it brings the energy of the Tablet into life through the Earth element. This is done through the Kerub of Earth, by the power of Adonai. With the Cup of Stolistes, a cross is drawn in the air in front of the Tablet. With the most passive weapon available, an empathy is created with the Three Holy Names of EMOR DIAL HCTGA. The Three Holy Names are the keys to tapping the power of the Earth Tablet.*

The Hierophant makes a cross with the censer and calls forth the name of the elemental king, IC ZOD HE CHAL. Under normal circumstances, these names would automatically be awakened by the calling of the Three Holy Names, but when called on directly by the Hierophant, it is done for a specific purpose—to direct the power of the Tablet.

In consecrations and grading ceremonies, the ray of the elemental king is the first to impregnate the aura of the respective

*The oral teachings, from Whare Ra Temple state that each of the Three Holy Names represents an astrological house. During the ceremony, these names affect the second to fourth houses and directly affect the life of the candidate in the three areas, which are as follows:

EMOR: Second House. Affects the possessions of the candidate and is meant to guide and arm him with the necessary values of this life. Taylor called this the "grounding" or "earthing" of the candidate, which instills a balance, helping him to cope with day-to-day activities.

DIAL: Third House. This affects the communicative ability of the candidate and helps him to strengthen the bond between Mends and family, as well as helping him to face problems on this level of existence.

HCTGA: Fourth House. Here, the inherited tendencies of the candidate are being helped and directed towards a common good.

The fundamental philosophy behind this is that, as the candidate goes through the four elemental grades, he goes through the 12 astrological houses. Each one of these is strengthened in turn, thus helping the candidate function on the level of mind, body, and spirit.

object. The Hierophant creates a vital etheric link by merging his aura with that of the Tablet, and then with the object in question, during pertinent parts of the ceremony. When this force is withdrawn at the close of the ceremony the vibration, in empathy, continues apart from the etheric link. The elemental king is also the main coordinator for the Tablet, and directs which forces go where.

During the ceremony, through the temple officers, the elemental king enters the etheric aura of the candidate through the chakra centers. His energies are linked to the diversification factor. He raises the vibrational pitch of the candidate's aura so that it corresponds to the elemental plane related to the Earth element.

Advancement: First Part

The Hierophant announces that *a dispensation* has been given to admit the candidate and orders the Hegemon to *give* the customary alarm.*

The Hegemon goes clockwise to the antechamber, where the candidate is blindfolded and given the Cubical Cross. The Hegemon instructs the candidate in the correct knocks to gain entrance to the hall. The Kerux holds the door ajar and by doing so creates a gap in the portal of the ceremony, which in the 1=10 should extend to the door of the antechamber. With the door open, the portal is kept slightly open. The Hegemon and Sentinel form a triangle with the Kerux.

The figure on the following page shows the temporary break or gap in the portal, which is balanced on the outside by the Hegemon and Sentinel. If a Sentinel is not present, the Hegemon con-

***This is taken from Psalm 127 and shows yet another layer of Golden Dawn ritual training—the magical use of the biblical Psalms. Although scholars have written extensively on this subject, we would refer the reader to a work that Mathers was familiar with, and often used. This is *The Magical Use of the Psalms*, which was published originally in 1788. There were a number of notations (with Mathers' initials) that referred to the *magical uses* of the Psalms on a Golden Dawn master copy of the 1=10 Ritual. This particular Psalm was said to protect a newborn child immediately after birth. The Golden Dawn modified this to protect the candidate after entrance to the hall.**

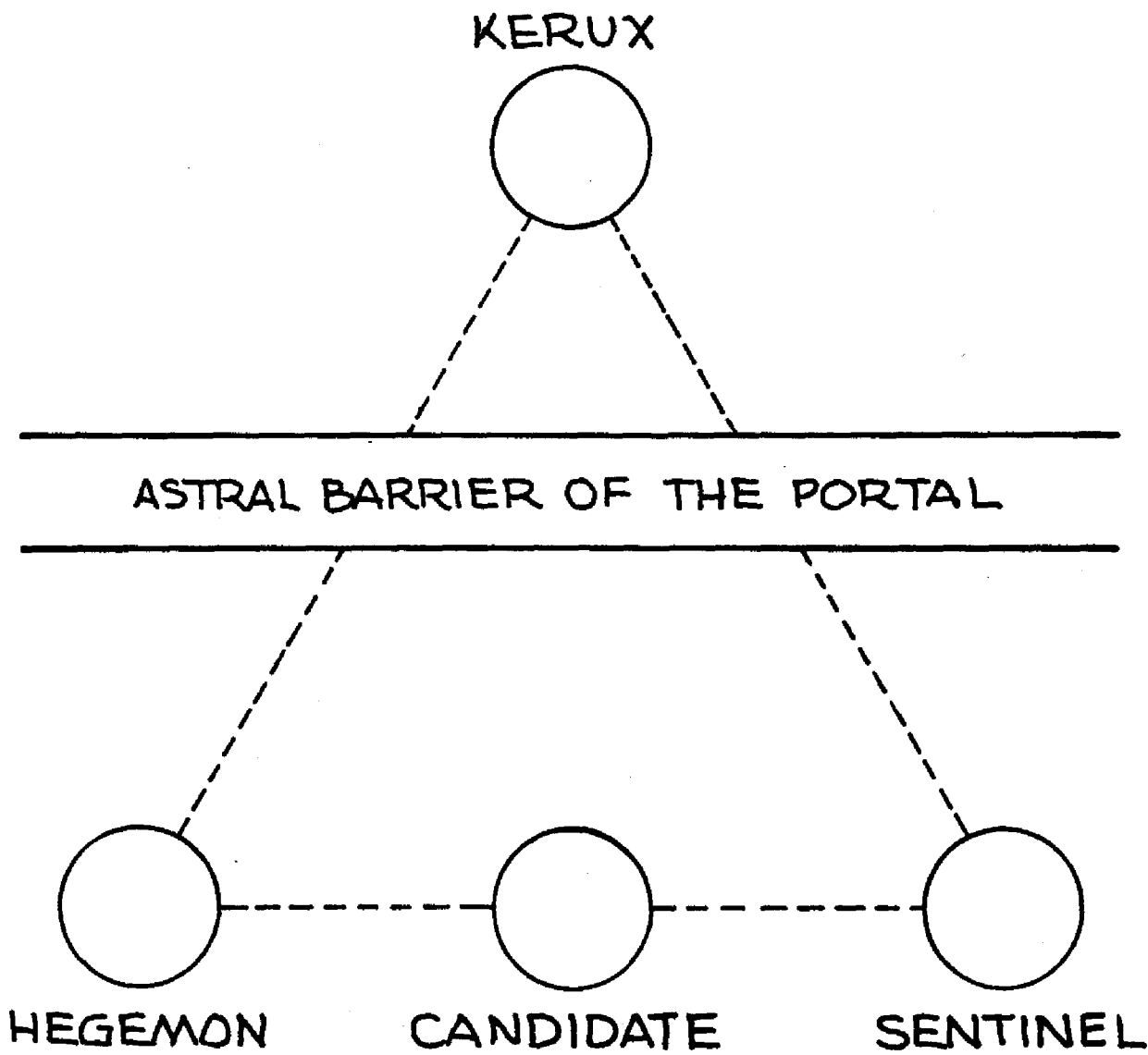

trols the opening and closing of the portal. The symbology of the Kerux dimming the lights is twofold. First, the candidate enters a new area to him or her, the blackness of the Void. Second, with the symbolic lowering of the lights, the Hierophant lowers the vibrational pitch of the portal and allows the candidate to breach it, while the Kerux and Hegemon hold the vortex together.

The candidate gives the signs, word, grip, etc., of the Neophyte Grade to show that he has passed the previous initiation. The candidate carries the Fylfot Cross in his right hand, and it is taken by the Kerux, who holds it right up until the time when the cross is explained to the candidate. He *is* then placed between the Pillars. His Higher Self is held in check, not only by the current of the Neophyte, but also by the Goddess Het-Hert, Guardian of the Immeasurable Region. As the candidate kneels, with his right hand on the earth and with his left hand throws salt to the North, he uses the 'As is above and so is below' principle. The element he touches with his left hand, the microcosm and the macrocosm of the Earth element in nature, extends not only in the soil, but to the stars as well.

The next phase of the operation is the purification of the candidate by Fire and then *by* Water.* In the next phase of the operation, the Hierophant describes the fundamental floor of the Temple (one level of it, that is), which is the Tree of Life of Malkuth of Assiah. In doing so, the Immeasurable Region becomes measurable, for the candidate has been provided with , a blueprint of the Tree of Life (which he learned in the previous grade). The controlling power on the floor at this time is the god-form of Het-Hert. She has formed *a* cocoon or astral station around the candidate *as a* form of protection, and also *as a guide*. The Kerux, as Anubis, leads the candidate towards the station of Samael, where he is challenged by the Hiereus,

**Here, the candidate has achieved the status of salt of Fire. To go on to the next phase, which is a reduction to the watery principle, he is purified with Fire, then with Water. The biblical quotations from Matthew 5:13, "Ye are salt of the earth," and Mark 9:50, "have salt in yourselves and peace with one another . . .," all relate to peace and wisdom being analogous to salt, marking a higher level of understanding.*

telling him of the area he cannot enter. Here, the god-form of Het-Hert has saved the candidate from certain oblivion, and now draws him back along the way he came, guided by Anubis.

At the command of the Hierophant, the candidate goes towards the Pathway of Good. The god-form of Metatron, in the form of the Hegemon, dazzles the candidate with his brilliance. Once again, he is protected by Het-Hert, who softens the glare and protects him from the glory of the reflected godhead. Upon returning to the station from which he started, the candidate has learned that there are no shortcuts to the Hidden Knowledge, lest he be blinded by the brightness of what he will find or corrupted by the darkness that could engulf him. This is also the first lesson in patience. Now, therefore, at the command of the Hierophant, he enters the Middle Path. At this point, the candidate is conducted to the foot of the Altar, guided by Anubis in the form of the Kerux.

When the candidate is a foot in front of the Altar, he is barred by the Hieres and Hegemon, who cross their elemental weapons before the Altar.* -

This barring is done by the lower Sephiroth of the Supernals of the Tree of Assiah. When the Hierophant comes forward, he uses the Light from his scepter to unblock the energies of the higher Supernals.

At this juncture, the energies start to change the aura of the candidate, concentrating indirectly on the lower chakra center on the back through the kabbalistic Sephirah of Malkuth around the feet of the candidate. The Hierophant opens up the energies of the Tree. As he comes forward, he assumes the form of Sandalphon, desiring to link with Metatron in Kether. Guided by Sandalphon, the candidate is then shown the drawing at the base of the Altar.'

*Both officers turn clockwise to face West, as they generally face East and only turn for specific reasons.

†Genesis 2:24, for the speech of the Hierophant. Although Metatron is associated with Chokmah, this is very much the level of reflected glory, toned down, so that the candidate is able to grasp his energies. Metatron inhabits Kether, but works through Chokmah, though, at this point, the energies are now directed from Kether due to the efforts of the Hierophant as Sandalphon.

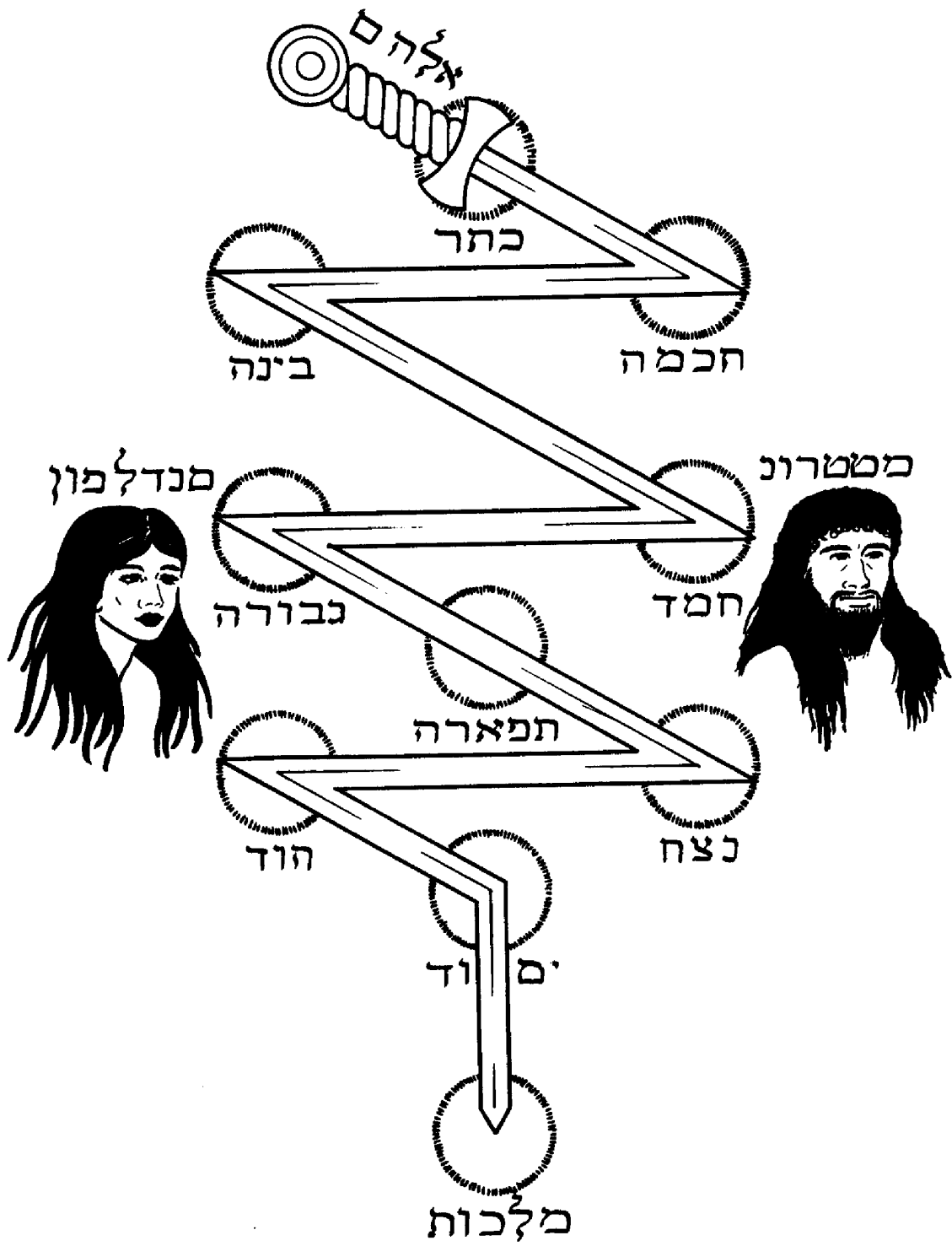

The Flaming Sword

The diagram of the Flaming Sword (at left) shows the descent of the energy through the Tree, from Kether to Malkuth. An unpublished Golden Dawn document states: ". . . the Hierophant, as the Great Sandalphon, sheweth his power through the grasp which giveth the power of Metatron to the Neophyte . . ." What Mathers was trying to show here was that the Hierophant should draw the power of Metatron through his scepter, from the Altar, and then directly inject this into the aura of the candidate, through the grip with which he hold the candidate. The Hierophant actually points in the general direction of the Altar—or to be more precise, the top of it—where the interconnecting currents of energy cross. He draws directly from this juncture.*

The candidate is invested with the Step, the Sign, the Word, the Number, and the Password. Of this, the most important is the Sign, which is given by raising the right hand to a 45-degree angle. The higher teachings of this sign relate it to the power of the Earth, for during any astral contact with any entity, this sign may be given as a sign of its Earth nature.'

The Hegemon draws the candidate's attention to the Flaming Sword and explains its symbolism, which the candidate experienced directly at the hands of the Hierophant. The symbolism of the cross in the triangle is in essence much the same as the Flaming Sword principle—Spirit descending into matter.

The general meaning of the Enochian Tablet of Earth is given

***This method of energy transference, by touch, is a very old one. Taylor demonstrated this transference to us. He could project energy into an aura eight feet away, without touching, and achieve the same result—but without use of a scepter. To do this, one invokes Metatron, through AHHH. The energy is transferred to the candidate by way of Sandalphon. As the energy goes into the candidate, it manifests itself from the top of the head down, much in the same manner as in the diagram.**

†When contacting plant life, one will often find, when requesting that the spirit of the plant reveal its nature, that it will give a series of elemental signs, which are generally a mixture of more than one element. By performing this sign when one invokes the element of Earth during the invoking pentagram ritual, additional force is brought to bear that results in more control for the user. It is also used extensively in alchemical operations. The actual lifting of the hand signifies the raising of the veil to allow the forces of Metatron to mingle with those of Sandalphon in the Tree of Assiah.

and related back to the angel Ave and the biblical Book of Enoch.*

The Fylfot Cross' is handed to the candidate by the Kerux, and is explained as pertaining to the solar system in general, with the Sun, four elements, and 12 signs of the zodiac given. The Kerux then takes the candidate out.

The next gesture, by the Hierophant, is something that was dropped in many Golden Dawn temples, including Whare Ra, except when Jack Taylor was Hierophant. He continued to teach the way of his teacher, who was a protege of Felkin. In order to close the Hall for the first part of the ceremony, without due disruption to the next part, the Hierophant grasps the uppermost grip of the scepter, the Path of Gimel and, with a movement of the cross, temporarily closes the Temple. The wording for this was left up to the individual Hierophant, but the gesture *and* purpose had to be clear. The use of the Gimel part of the scepter effectively cuts off the power from the Supernals of the Tree, as the grip is above Daath. The god-forms and stations will only exist for a short period of time. The initial current of power will still come through, but will be held in abeyance.

***The Inner Order H Document, "Clavicula Tabularum Enochi," as it is sometimes called, states:**

Now as to the general significance of the tables, and of the Officers of the Angels, and other remarkable observations, these tables contain all human knowledge; they stretch to the knowledge of Solomon: for out of it springeth Physic, the knowledge, finding, and use of all metals, the virtues of them, the congelations and virtues of stones (they are all of one matter)—the knowledge of all Elemental Creatures amongst us, how many kinds there are, or what they are created. Those that live in the Air, Water, or Earth, by themselves. The property of Fire, which is the secret life of all things:— but more particularly, the knowledge of all mechanical craft whatsoever; the secrets of man, the moving from place to place, as in the country etc. The knitting together of Nature, and of things that may perish; as well as the enjoying and knitting them together, etc.

†The Fylfot Cross, shown on the next page, is a universal symbol, appearing in early American, European, and Oriental cultures. Its two shapes relate to the passive and active principle. The counterclockwise shape of the Golden Dawn version relates to the inward spiral and Goddesses, such as Artemis and Astarte, who are attributed to the Earth and the feminine attributes. The oral teachings of the Golden Dawn relate the Fylfot to the swirling power of the Sephirah Malkuth, that revolves inward so that the energy then goes back up through the Middle Pillar of the Tree to Kether.

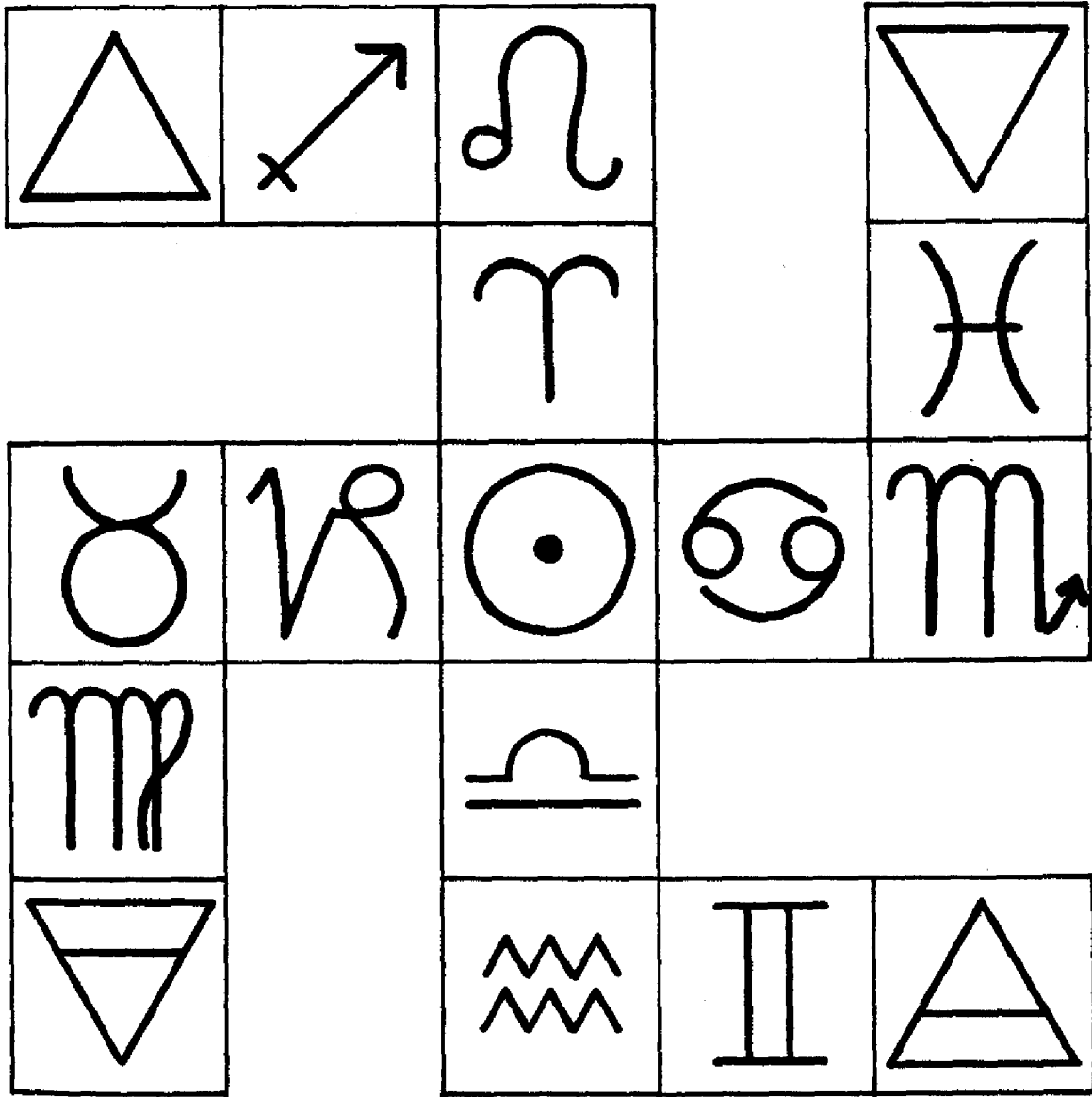

The Fylfot Cross

Part Rye

When all officers are seated, the Hierophant will, by the Gimel grip of the scepter, open the ceremony in exactly the same way as he closed it at the end of the previous session, with only the wording being altered slightly. He then instructs the Kerux to admit the candidate once the alarm has been given. The position of the entry into the hall is exactly the same as in the first part, though, once the door is open, the Kerux steps back, and the candidate steps forward, with the Sentinel directly behind him.

*The Temple ground plan, shown on the following page, relates to the astral form of the Temple of New Jerusalem. Dr. Felkin's copy of the book Cannon contains a number of sections which describe certain parts of the Outer and Inner Order Rituals of the Golden Dawn. The particular passage, ascribed to the "Ground Plan of the 1=10, Second Part," states:

The name of the Tabernacle in the Hebrew (Ex. **XXV.9**) is MShKN, and yields 1060, one less than one length of a vesica 612 broad, two numbers are found in the names of Apollo and Zeus . . . The number 1060 is also the diagonal of a square whose sides are 749.5, and this square is contained within a rhombus ascribed within Saturn's orbit.

(The figure of the enclosed hexagram for the second part helps show exactly where everyone and everything is placed, and why. This has been previously unpublished.)

Saturn is also ascribed to the element of Earth. The circumference relates to the portal, or edge of the magical aspects of the ceremony. The lines show the main currents of power running through the Temple, while the Hegemon is seated directly in the center of the Temple.

Each officer has charge over one or more items that are removed and replaced with the necessary props for the second part of the ceremony. These generally pertain to his or her role in the ceremony. The officers all move silently and efficiently and in a clockwise manner, and, although the Super-nals are sealed by the Hierophant, the Temple is not closed, for it sits in a state of suspended animation, and no loud or sudden movement or unnecessary talk must take place to disrupt the energies.

The Hierophant supervises the Temple transformation, noting that all is in place. A diagram kept hidden in his clothing is advisable, as the "high" from the ceremony tends to make people light-headed, and things can easily be forgotten. It is advisable to keep replacement diagrams and ornamentations, etc., inside the side altars.

Note: No one must cross the portal throughout the duration of the ceremony except where explicitly stated in the ritual.

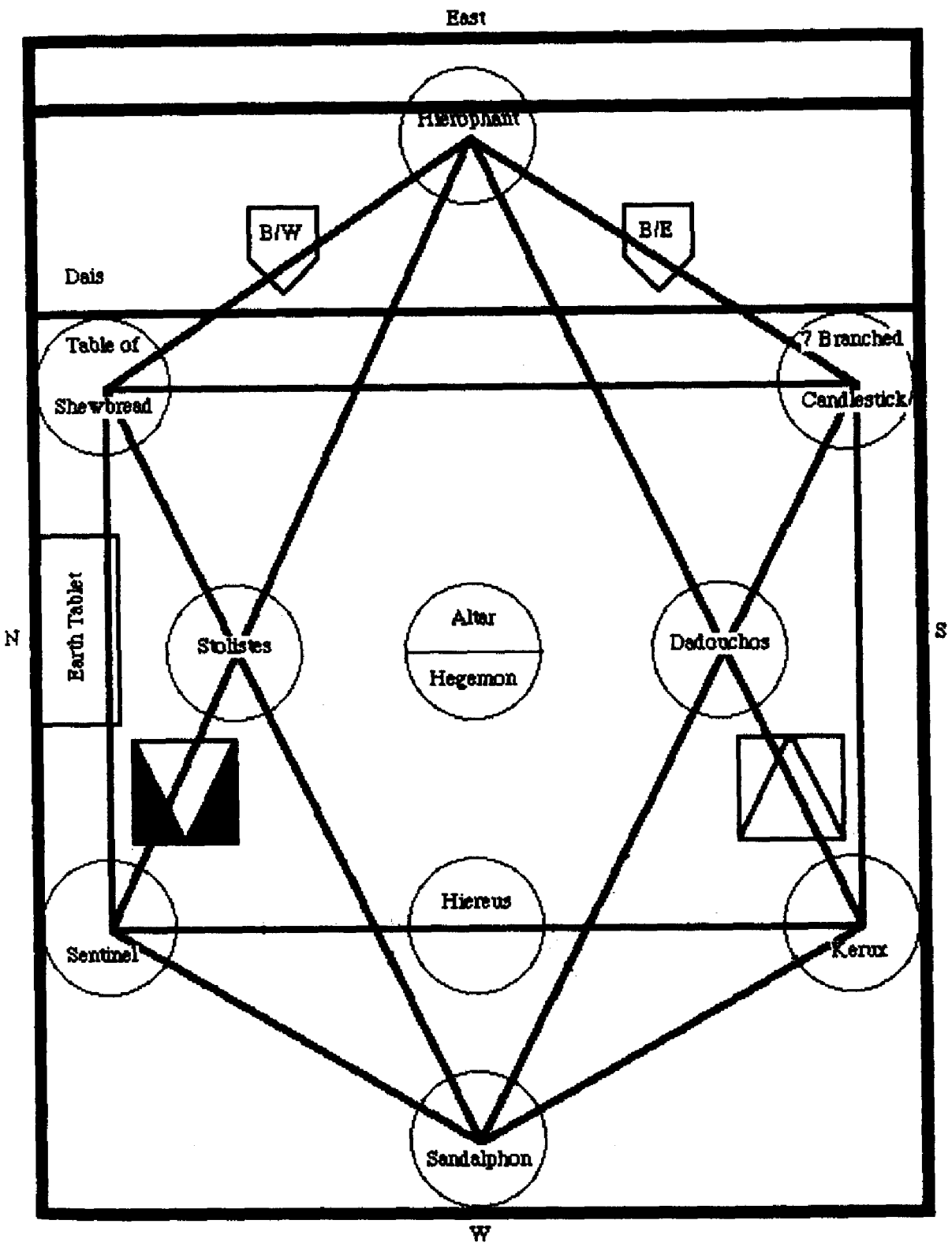

Temple of Jerusalem Applied to Second Part

They form another triangle, with the candidate at the apex. The Hierophant tells him where the Symbolic Altar of Sacrifices stood in the Court of the Tabernacle, which relates to the Qlipothic or negative influences which were left behind during the previous purification. Dadouchos purifies the candidate with a cross and three swings of the censer. This forms the symbol of the cross in the triangle (each swing being a point of the triangle) which is also the symbol on the Altar. Here the link is picked up from the first part of the ceremony. The Stolistes *also* purifies in a similar manner, giving equal balance to the purification rite.

The Hierophant tells the candidate of the symbolism of the Laver of Brass, and its relationship to purification in the Old Testament. The term "Waters of Creation" had its roots in both Egyptian and Hebrew symbolism, for water is the symbol of birth, which in this instance is analogous to the new beginning of the candidate and is to a certain extent a replica of the magical meaning of Psalm 127.

The candidate is taken to the North, where he is barred by the Hieres. On giving the Grip and Signs of the Neophyte, he advances to a position between the Pillars. Hegemon comes forward to face him, and he is again challenged. This time, he is asked to give the Grip and Signs of the Zelator. Kerux returns to his seat, while Hegemon escorts the candidate to the diagram of the Table of Shewbread (see next page), which represents the 12 zodiac signs, the 12 tribes, the 12 loaves, and the 12 Foundations of the Holy City.*

The pressure of the grip of the Hegemon is increased dramatically while he explains the symbolism of the Table of the Shewbread. This diagram is more than a mere diagram of 12 colored triangles, for it has a station of its own in this part of the ritual.

***At this point we are shown an Outer Order version of the diagram. Mathers expanded more fully on this diagram in the Practicus Adeptus Minor Grade, under the heading of "The Knowledge of the Ritual of the 12 Gates in Skrying and Travelling in the Spirit Vision; answering to the Diagram of the table of the Shewbread." As one advanced through the four levels of the 5=6 grades, the Inner Order explanation of this diagram was then made clear. (See *Secret Inner Order Rituals of the Golden Dawn*, page 174. Part of this previously unpublished lecture is included in *Golden Dawn Enochian Magic*.**

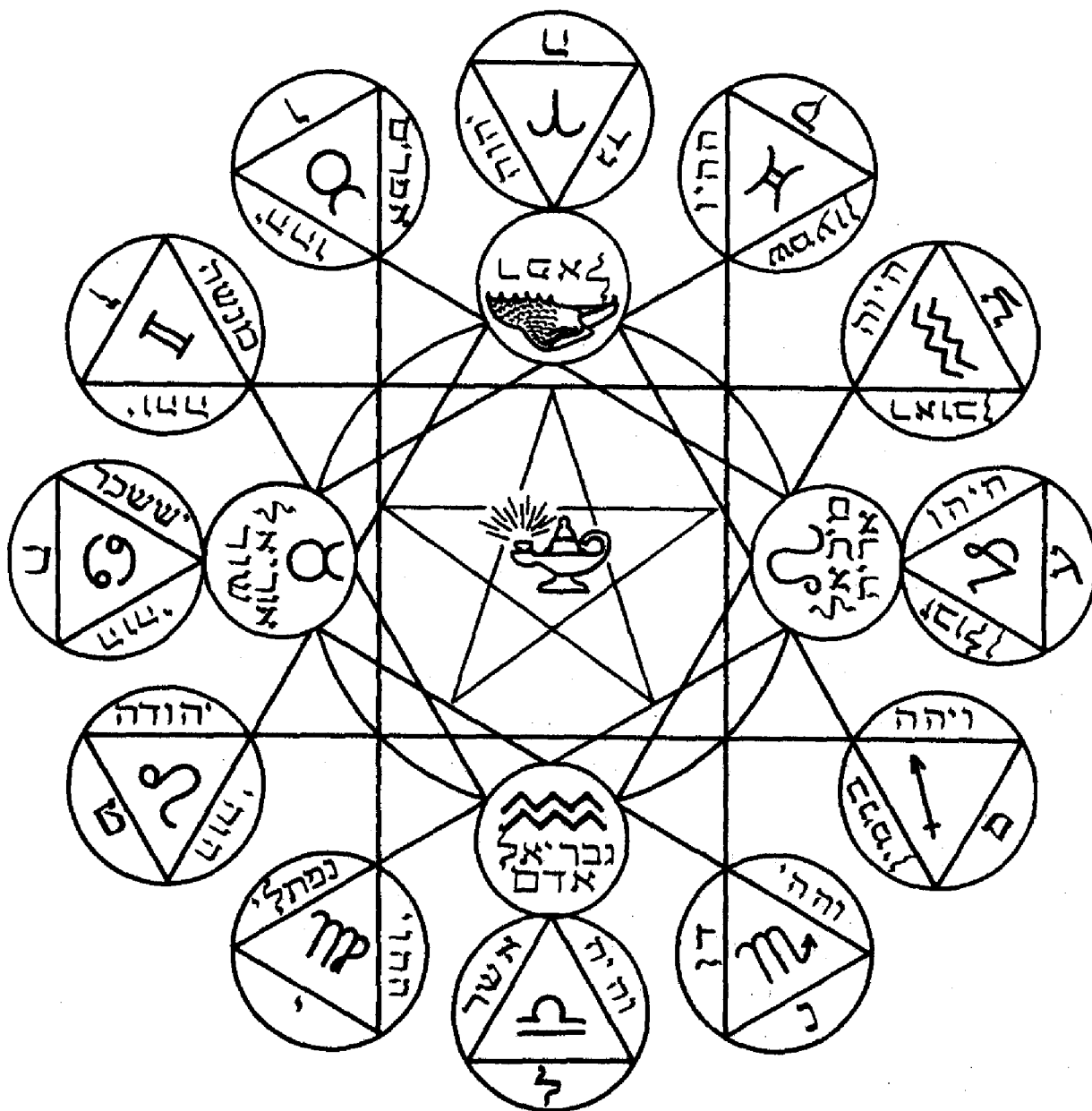

Table of Shewbread

(Very few of the Golden Dawn diagrams were colored. At Whare Ra, the Adept would often go back and color the diagrams in the colors of his or *her* choosing. I am unaware of what the temples in *England* did.) It is the function of the Hegemon to link the Ruach of the candidate to the flashing tablet of the shewbread, for this is exactly what it has become. Its *energy is* directed by the Hegemon into the aura of the candidate, to make him more aware of the effects of nature on himself.

The Hegemon and Hieres conduct the candidate to the diagram of the Seven-Branched Candlestick (shown on next page), where its relationship to the number seven is given. This shows similar influences to that of the preceding diagram, but on a more direct mode. Through the Ruach of the Hieres, the candidate is shown another flashing set of colors. On the level of the Outer Order, it relates heavily to the planets. When this diagram is presented in the Practicus Adeptus Minor curriculum of Mathers, it is described as "The Knowledge of the Secret Ritual of the symbolism of the order of the Days of the Week of Creation, answering to the diagram of the 7-Branched Candlestick." Its roots are in the first seven days of Genesis.*

From this point, the candidate has been taken the route of the Lightning Flash, from the base of the Tree. It is designed to instill in him a concept of learning. The candidate is led to the West of the Altar where the Hierophant comes forward swinging the censer (in the shape of the cross in the triangle) and gives the speech concerning the Altar of Incense.

The Altar of Malkuth is a physical representation of the spiritual Altar of Incense.

The title of Zelator, or *Pereclinus de Faustis*, is bestowed on the candidate. It is to remind him of the early alchemical theme of the Rosicrucian grades. The Zelator was the stoker for the athanor of the alchemist, the most menial of *all tasks* with which to begin his apprenticeship in magic. Its vibratory pitch opens up the mysteries of the Earth element for the student.

***Refer to *Golden Dawn Enochian Magic* for full Inner Order explanation of diagram.**

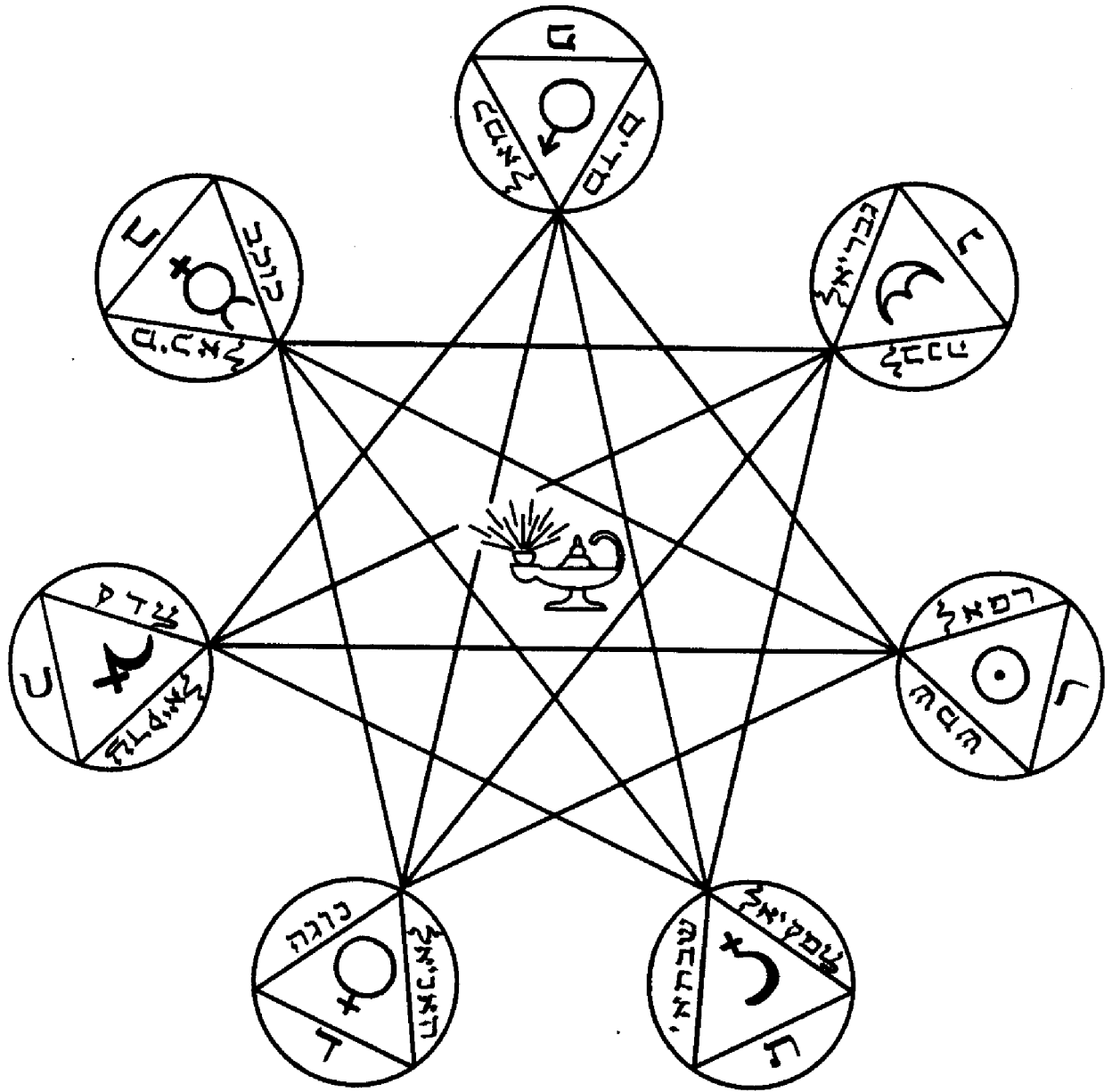

Seven-Branched Candlestick

The Zelator is led to a seat in the Northwest by the Kerux, who uses his wand to indicate where he must go. The Kerux institutes the proclamation that the Zelator is now admitted to the mysteries of *Aretz*, the Hebrew name for Earth. The "Thirty-two Paths of Wisdom" calls this the "Path of Resplendent Intelligence." On this path, one realizes that one is in Malkuth. By that virtue, one attains the unification with the luminations from Kether, because of the central Pillar of the Tree. The old saying, "Kether is Malkuth and Malkuth is Kether," very much applies here. The reference to the "Throne of Binah" by the Hierophant is very complex. It must be remembered that Binah is the first separation of feminine polarity from Chokmah, and gives the first stirrings of a new life, being formed on an as-yet-unmanifested level, which relates to an entire Tree before manifesting in a new area of development.*

Closing

After the proclamation that the Temple is about to be closed, all officers face the East and adore the Lord and King of Earth. They form a hexagram in front of the Tablet and say the prayer of the Earth Spirits in front of the Tablet.'

*The meanings of some of the titles of Malkuth, *as given* in the speech of the Hierophant, are as follows:

"Gates of the Shadow of Death"—This shows the karmic pattern of lives one lives through in which one never really dies.

"Gate of Justice"—This shows that everything must be balanced before ascension to the next level of existence.

"Gate of Prayer"—This shows the devotional aspect of life.

"Gate of the Daughter of the Mighty Ones"—This relates to the birth of Earth itself, in terms of planetary relationships.

"Gate of the Garden of Eden"—The entrance way to the state of the Divine is through Earth and human incarnations.)

†This prayer is taken from Levi's *Transcendental Magic*, and, though there are some differences, they appear to be in that of translation from the French, as this book was not translated into English until 1896—some years after the elemental rituals had been written. The gnomes are the elemental spirits of Earth. Their king, Ghob, was said to live in the subterranean areas of the Earth and to have control of all metals.

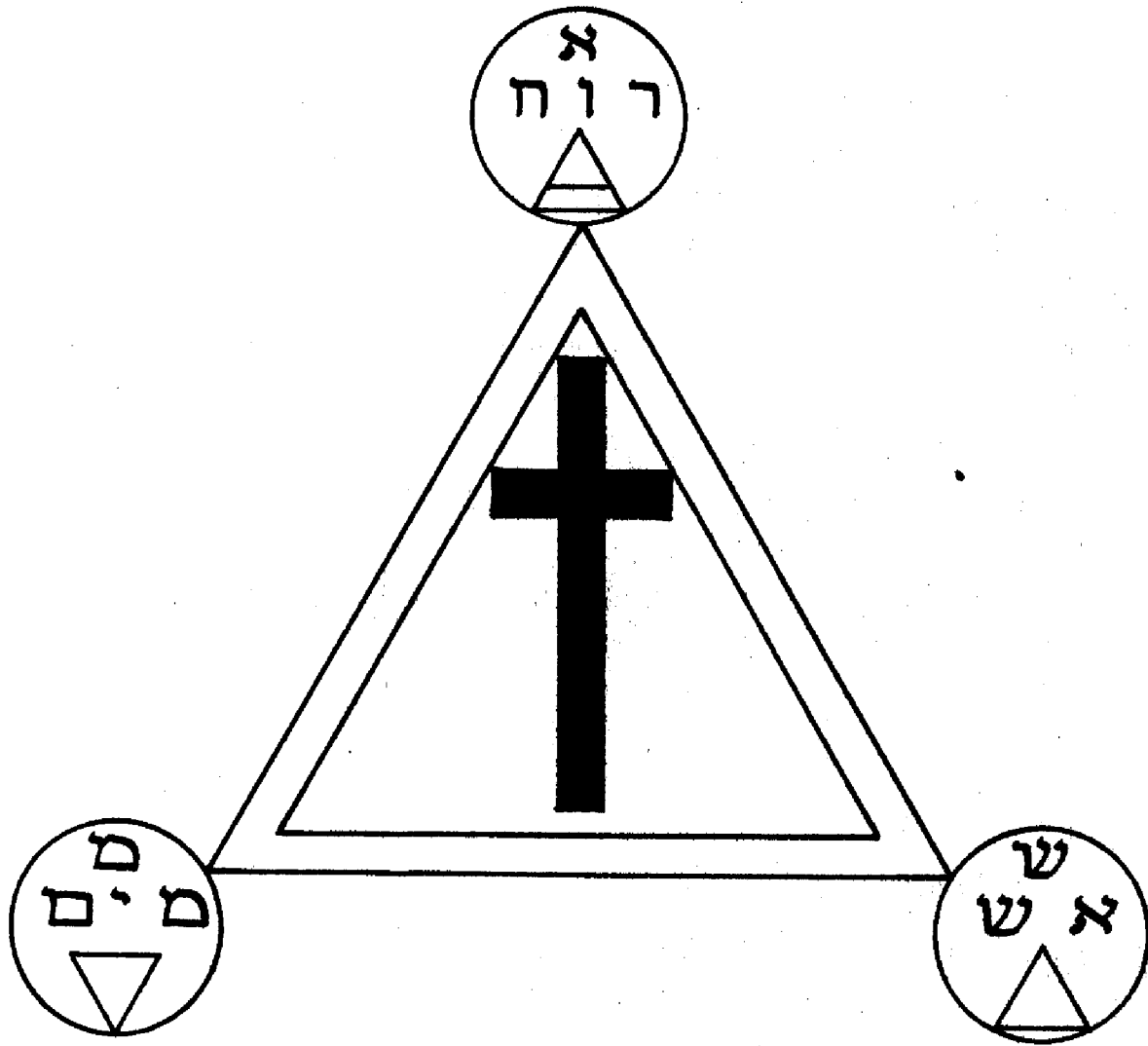

The Banishing Ritual of the Pentagram is done with the Hierophant's scepter, after the command to depart in peace. Again, this is done through the Earth Tablet rather than directly from it. The grade is closed with the 10 knocks of Malkuth by the Hierophant and Hegemon.

Once the prayer to the elements is read out in front of the Tablet, and the elementals are told to depart, the Earth aspect of the ceremony winds down. The elemental king of the Tablet of Earth starts to withdraw his energy from the tablet. The *use* of the scepter here cuts the power from the ceremony and also defuses the god-forms. The god-forms on the dais dematerialize, followed by those of the Temple officers. By the time those in the Temple leave the hall, their auras will be magnetically charged from the ceremony, but the god-forms around them will have ceased to exist.

The allocution is sometimes read out after the ceremony is finished. If so, all members remain seated until it is finished. This aspect of the ceremony depended on how vocal the Hierophant was feeling, and it was included in the candidate's copy of the ritual to study at his or her leisure.

Part 3

*Whare Ra Lectures
and Addresses*

*Lecture on the 1=10 Ceremony
for the Zelator Grade
Whare Ra Temple*

Introduction

Fraters et Sorors:

In order that we may get our ideas thoroughly into form, and be prepared to consider the symbology of the 1=10 Grade, it might be well just for a moment recall what each of us considers the purpose for which we are all associated together. For unless we have some real earnest purpose behind what we do, and impelling us, these our ceremonies are mere burlesque, and unworthy of the attention of grown men and women.

Now, I think there can be no doubt that for all of us the primary idea is that of self-development in some line or another. It matters not for the present what that line is, but we hope somehow or other to make ourselves nobler, wiser or better men and women than we were when we started. And also we hope to gain a further knowledge of the Inner Secrets of Nature, in that we may know more and be able to use those powers of nature whose existence we are conscious of but whose modes of opera-

Lion are hidden from the ordinary brain of man, hidden therefore from the man of materialistic science, and therefore called ordinary Occult. We wish to search out nature that thereby we may come more in contact with Nature's GOD.

I think that summarizes the position of all of us, although I suppose that the aim of every one is to some extent divergent.

Well, now, we believe that in this Order we can obtain a certain amount of help in that great quest. And I think, that all we who have got so far as to pass through the veil that separates the Outer from the Inner, can assure you who are still in the Outer that there is a great deal of help which is given in this Order. One or two ways which are given you may allow me to point out.

One is unknown to you and therefore you must take it on faith, and that is, that one of the Chiefs of the Temple primarily, and all the members of the Second Order to an appreciable extent, but in a less degree, do occult-wise bring an influence, a current of Will, to bear upon all members of the Outer from the Neophyte Grade up to the Grade of 4=7 which insensibly to themselves changes their nature, changes their character and their pose of mind towards the material and Outer Universe. You are not conscious of this. Only the most developed natural sensitives can be conscious of it, and only in a very vague and slight degree. Nevertheless, it does exist, and those of the Second Order who are sufficiently trained to develop their spiritual and clairvoyant perceptions, can perceive it. They can perceive the change in you which you yourselves for the time being are unconscious of until you attain some level and are able to look back on your previous course. Then you will see how that change gradually worked in you.

But there is another way in which this Order helps you, and that is by its Ceremonies, and by the symbolism of these Ceremonies, because as you gradually come to understand the symbolism of grade after grade you will see that they are really, as it were, algebraic formulae which teach you how to develop yourselves in the first instance, how to guide, govern and rule your own body, in order that hereafter, when you have learned

that lesson, you may apply the same formulae precisely to the influencing of the Outer World. First of all you must learn to guide and regulate and govern yourselves and your own bodies. Secondly, you may be allowed to influence material bodies beyond and outside yourselves.

Now, I have spoken, and some of you probably remember it, on the symbolism of the 0=0 Grade, and in that lecture I pointed out that the temple, as arranged for the 0=0 Grade, actually represented in a miniature diagram as it were, the whole of existence, that is to say everything that the Creator has breathed forth into being, and that the *cubical altar* in the centre represented the Material Universe, the Officers representing the various powers by which the Will of the Creator operates upon that Material Universe. And that first teaches you how small in the general scheme of the universal Existence, is what we know as the Material Universe and of the ten squares constituting the Cubical Altar, only one, and that basal square, the square that stands upon, represents the utmost part of the *material Universe* which you can see, handle or hear, or know by the five senses, and that from the position of the Altar, is hidden.

From the time, therefore, that you enter this Temple in the 0=0 Grade, you part with all knowledge which you can attain through the five senses or any reasoning from these, and you seek to penetrate into the domain of the causes which lie beyond—the concealed Majesty of GOD. Now, here in the 0=0 Grade, you stand as it were, upon the threshold, as you might be standing between the doorposts of the doors and looking in. So stand you, in that 0=0 Grade between the Pillars which are symbolically called the *Immeasurable Region*, which you will remember, in this grade which we have just conferred upon you, the Very Honoured Hierophant invites you to enter as you stand between the Pillars.

Now, between the time that you enter the 0=0 Grade and the time you pass into this Grade, you have to study and be examined upon a certain Knowledge Lecture, of that knowledge I spoke somewhat in speaking of the 0=0 Grade. There is no need

to say more about it now, but in that Knowledge Lecture you learned the names and the translation of the names of the Ten Sephiroth, and tenth of these you will remember was Malkuth, and the English translation of Malkuth is the *Kingdom*. And I daresay a shade of wonderment may have come over you as to why Malkuth, the *Kingdom*, is the tenth. The natural man says within himself—surely *the Kingdom is the highest thing to aspire to?* When you attain the *Kingdom* that is all that can be desired or aimed at. How then comes Malkuth to be the Tenth Sephirah?

Well consider for a moment what is a *kingdom* without a *king?*—and in the days before there was a king is Israel, there reigned the Kings of Edom, the Lords of Forces. Now Malkuth is the *kingdom*, it is true, but the *Kingdom of Hell*. It is the lowest of the ten Sephiroth and it represents the *material world*. It represents the human constitution, the material, the physical, tangible body, which we share with all vertebrate animals. Now, what is the duty of MAN? MAN was created by GOD ALMIGHTY, a *living soul*, and his duty is to enter into his kingdom as a king, there to sit as a king enthroned in his kingdom.

Now that is precisely the lesson which is taught you in this Grade of 1=10. You are shown in symbolic language (in algebraic language as I may put it to you) how that process is to be accomplished. You are shown also a synthesis in symbol of the material body and also of all material bodies. Because the Hermetic axiom holds here as it holds everywhere *as is above, so below*, and his process is precisely the same whether it be the entry of a God into a planet, hitherto unoccupied and dead into his kingdom, whether it be the entry of the soul of man to take possession of his body, and to rule there as a King upon his throne, or whether it be man himself (that is afterwards) operating by magical power and taking possession of and influencing and ruling other bodies as a king upon his throne, whether it be the process of Alchemy which takes possession of the base matter and transmutes it into gold, or whether it be the influence of the Thaumaturge entering into the heart of nature and proclaiming changes there, it matters not; the formula is the

same, and that formula is given, absolutely given in full in this grade which you have just passed through. Now, to guard against any disappointment that might occur from large promises and larger indications of this kind, I may tell you that it is very little indeed that I can tell you now—it is very little that I know myself—and that little the nature is such that if I might tell it to you it would be wholly unintelligible in your present stage of advance, because while you are yet in the *Outer*, much of this language must be sealed language to you, and even if I might utter it, it would fall upon absolutely deaf ears.

But what I can do is to call your attention to prominent parts of the Ritual, and show you things which perhaps many of you may have passed over without noticing, and I hope to lead you to search out further matters of thought for yourselves.

Symbolism of the Temple

Now you will notice that the arrangement of the Temple is considerably different in this Grade from what it was when you were admitted to the 0=0. The Hegemon no longer sits between the Pillars, the Pillars are no longer placed in the East, but placed to the West of the Altar. The Black Banner of the West no longer stands beside the Hieres, but it stands beside the Hierophant. And here I may mention one thing that may be of use to you. Always notice whenever the Black Banner changes its position and whenever you find the Black Banner in a different part of the Temple it signifies a bar of some kind.

Now, you have been told that this Grade represents the tenth Sephirah of Malkuth, the Kingdom. You must look upon yourself as the *spirit of man* for the first time entering his body, but that he is the lord and ruler of it, and that if he allow his body in any way to dominate his will he is a king abdicating his throne. Take that conception first, because in the words that were inscribed on the Portal of the Greek temple *Know Thyself*, in your own self you will find the key to all mysteries. Look therefore upon the temple as an algebraic symbol of your own bodies, and look upon the Neophyte entering the temple as your

own Divine Spirit, informed by your own Divine Will, entering to take possession of the Kingdom of which God has given you. Therefore, here, as in the 0=0, it is Hegemon (the representative of the Pillar of Mercy, the the Path of Goodness, and the Synthesis of Equilibrium) who comes to bring you in. It is the equilibrium of the body, the perfect poise which is at peace with all the World, and therefore the representative of mercy, which brings the Divine Spirit. When the body is as poised, then the Spirit can enter.

Advancement: First Part

So it is the Hegemon who is properly and necessarily our leader, but it is the Sentinel, the Watcher Without, who prepares you to enter. Blindfolded, the King enters upon his Kingdom, blindfolded because he must have faith. By knowledge he can never enter; by pride of Will, by pride of accomplishments or attainments he can never enter; for man *may* study his whole life, he may attain riches and honour, but never by these means can be attain to the Kingship of his own body, but only by faith. Therefore he enters the Temple blindfolded, and it is not the Hegemon, representing mercy and Equilibrium, but it is the Sentinel who keeps and guards the door without, who thus prepares him. And as he enters, it is the *Kerux*, the Announcer, who bears the message to the body that the King is coming, who opens the door. So the body, perfectly equiposed and at peace, becomes aware that its king is entering.

Now, the *Hierophant* and the *Chiefs of the Temple*, sitting on the Dais, represent to you the power of the recondite and occult, powers beyond anything you can see, know, or conceive at present, they have emerged through the Veil from the concealed Mystery of the Inner, of the Second Order: Therefore within the Body of Man it is the indwelling Spirit of God who is to you as the Chiefs of our temple, the Chiefs of the temple of your Body. Therefore the *human spirit* enters upon that Temple of your body, silent in reverence, *the Divine Spirit of GOD* indwelling and permeating that Temple. Then *as* you enter the Temple

comes the solemn warning of the Hierophant: "Except the ADONAI build the House their labour is but lost that build it: except ADONAI keep the City the Watchman watches but in vain." Another exhortation to faith, because unless the Divine Spirit blesses you and makes you prosper, you may strive forever and you will never attain the smallest step, but if that assistance and blessing be granted, then everyone, no matter how weak, no matter how feeble, how erring, may aspire to the Kingship of the Kingdom of Malkuth.

There again comes the lesson of faith. No matter then how slow be your progress, no matter how frequent be your stumbles and falls, if ADONAI builds the House, the house will be built, and with the blessing of ADONAI your Spirit, informed by human Will, must at length sit upon the Throne of the human body.

Then does the Hierophant inquire why, by what aid, you seek admission to this Grade. The answer is *five-fold—the Mystic Pentagram* again. There are five aids:

First and almost always by the guidance of ADONAI, for without that you can do nothing.

Secondly, by the possession of the requisite knowledge. The knowledge you must have, but it profits nothing without the guidance of ADONAI.

Thirdly, by dispensation. That shows that not only is it the guidance of ADONAI that you trust to, but a permission which has come from behind the Veil to allow that King to enter upon his Kingdom. And in the human body that dispensation is represented by the Will to succeed in attaining Kingship of the Body.

Fourthly, you seek admission by the Secret Signs, Tokens of the 0=0 Grade. Something of this you know already and much more you will learn hereafter. You know already on entering the 0=0 Grade you are as a blind man groping in darkness. You step as one entering a threshold. You place the finger on the lips as vowing Silence and invoke the name of the GOD OF SILENCE, HAR-PAR-KRAT. There is much more in this than you know,

but so much is sufficient for the present. By these signs of humility, of groping, of seeking for wisdom, of promised silence, you ask admission.

And *lastly*, of the symbol of the Hermetic Cross I shall speak a little later on. The Sign of the Hermetic Cross is peculiarly appropriate to this Grade, and there is little more than that may be said about it beside what was said by the Hierophant in explaining this symbol. And of course I must also ask you to remember that although I am taking the symbology of this Grade with reference to your own bodies, this symbology represents also the World, it represents also the Solar System, and you can as easily translate this symbology by imaginary light, and therefore Divine Guidance and planetary Gods coming into a dead planet such as the moon (which is an assumption of Kingship), as you can take the material body and the coming in of a king.

The Hierophant asks for the step, sign and grip of the Neophyte. For the present it is sufficient for you to take that to mean that you must give a visible and tangible evidence of having passed that Grade and it is only then that you are placed between the Pillars. Now, you remember that I told you that the Pillars are *the Portals of Occult Knowledge—the Mystic Gateway*. The *Portals* are hung up here on the East Wall and I shall come to them presently. But wherever you see those two Pillars you know that there is the Gateway, and you will notice as you go through the other Grades that every time you enter this Temple for a fresh grade the position of the Pillars will vary—sometimes they will be in one corner, sometimes in another, sometimes beside the South Wall. They will be in various places, and you must notice these, particularly with reference to other parts of the Temple, and observe that *there* is the gateway of Occult Science.

Now, in this particular Grade the Pillars stand to the West of the Altar, and you are placed between them, facing the cubical Altar of the Universe, *still* blindfolded. In faith, therefore you reach the portal of the *Immeasurable Region*, and from thence

as a king surveying his kingdom, you must imagine your spirit, guided by your Will, looking towards the material part of our body, your own *material universe in fact*, symbolized by the cubical Altar in front of you: and in that position you pledge yourself—a king coming to take possession of his kingdom must indeed take the Coronation oath—you pledge yourself to adhere firmly to the same strict secrecy which you have previously vowed to maintain, and you swear by that kingdom which you are coming to take possession of, you swear by the earth on which you kneel.

After taking the Salt you begin to see. The hoodwink is removed and you see the temple. You see that the lights upon the Altar are unshaded, showing that you have passed from darkness into light. Then you take a few grains of Salt from the platter and scatter them towards the North. The North is the region of cold and darkness and is also the side of the Black Pillar of severity, and the North is also the side from which the powers of Earth operate upon the Temple. You say, "Let the Powers of Earth witness my Pledge" and then have to be purified again as before. Now the Hierophant speaks directly to you after having tested you and received your path. You are told what this kingdom consists of, under the symbology of the Garden of Eden. "TETRAGRAIVINLATON ELOHIM planted a garden eastward in Eden," and further than that there were two trees in it: (1) the Tree of Life and (2) the Tree of the Knowledge of Good and Evil, and the last Tree is the one that has two Paths.

The two Paths are symbolised by the Two Pillars, and by the Hieres and Hegemon, the Guardians of the paths. Now, when the king, the *Spirit of man*, enters into his body, determined to rule there, the two paths are presented to him. He can rule in one way or he can rule in another. He can guide that body voluntarily outward into the outer darkness, away from the Light of GOD into pure matter and separation from GOD. And mind, this is kingship too, it is not the yielding to the body, but is definitely and by determined design carrying the body along the path of separateness. This is the *kingship of the Devil*.

Now, the *Spirit of Man* which enters blindfolded, knowing

only good, knowing nothing of the distinction of good and evil, will first endeavour the path of separateness, that is always, since the fall of Man, the first impulse towards separateness, and towards the *kingdom of the Devil*. The Hidden Knowledge appears to be best attained in that way, because the "Wisdom of the Devil" is that GOD has hidden this knowledge from jealousy, so that MAN should become as GOD.

That was the voice of the Tempter in Eden, and it has been the voice of the tempter ever since. But there stands the Great Angel Samael, blocking the way, and from that moment that the Hieres puts on the form of that Great Angel and stops the soul progressing on the path of Evil when he says, "Return, for thou canst not pass me by." The Neophyte then returns back to the threshold where the journey begins again only this time on the path of good, though here again he is warned back by the angel Metatron, for it is nigh on impossible for the Soul of man to go on by that Light. The wise man gazes upon the material universe and beholdeth therein the luminous image of the Creator. "Not as yet canst thou bear the dazzling radiance of that Light." So, then, you see, before the Soul of Man lie two things, both of which are barred from access. The weak and foolish man gazes upon the face of nature and beholds therein nothing but confusion because he has not the faith in GOD which enables him to see the equilibrium in the apparent disharmony. The wise man gazes upon the face of nature and beholds GOD through His Outer garments, but that vision is not for the Neophyte yet. Then there is an *alternative*, and the Hierophant says once more, "Let the Neophyte enter the Straight and narrow path which inclineth neither to the right hand nor to the left," the path of absolute equilibrium. And as he would enter upon this Path, Samael and Metatron, the keepers of the paths of good and Evil bar his way. The Hierophant steps down, the image of the Divine Spirit which is in him, whose sceptre draws down from the Eternal Uncreated Light, a ray with which to illuminate the darkness of the material universe, and with that sceptre of Power he strikes asunder the weapons of the two angels who guard the Paths and allows the Neophyte to enter by this path-

way, the feminine power and the power of mercy who prepares the pathway into the Light Divine. Only by sceptre of power and by the Divine Life, it is possible that the Neophyte can enter the *Immeasurable region* and only by that Divine Spirit dwelling in him can the Spirit of Man attain to the lordship of the kingdom of his body.

Thus you see the obstacles that intercept your path as you strive to obtain the mastery over the material body. It is a difficult task and the more you meditate upon the symbology of this temple as it is arranged or this Grade and upon the words which are spoken by the different officers, the more you will see how your spirit has to get in obtaining mastery over your body, how the king has to obtain his rightful throne.

So the Hierophant having thus thrust aside the opposing forces and interposed for you, shows the Flaming Sword and the Cherubim which are placed in the Garden of Eden to keep the way to the Tree of Life open. It is the Tree of Life to which you are aspiring, and the Tree of Life these ten Sephiroth whose names you in this Zelator Grade have learnt, and whose arrangement you now proceed to learn. You are also told the Signs and secrets of this Grade. As there is a great deal in these Signs you can be told now some of their significances.

You should always be able to remember the Sign of the *Interposer* as you give that Sign in remembrance and recognition of the interposition of the Hierophant for you. Therefore you should remember in giving this sign you are recognising and recalling remembrance the sceptre of power bringing down the Divine ray, the Spirit of GOD dwelling in you which interposed to allow the King of the Body to approach his rightful throne.

ADONAI HA ARETZ, the Grand Word, means "Lord of the Earth" in your own body, and not allowing the kingdom to dominate the King. The Password *Nun Heh* refers to an "ornament." "I will bind ye for an ornament upon my hand and for frontlets between my eyes," saith the Lord. The Material Body, the temple of the Holy Spirit, is indeed an ornament worthy of God Almighty, when dominated and ruled by the Divine Spirit which is the King of the body. Therefore *Nun Heh*, the ornament, is a

very fitting password.

Now we come to the Three Portals. We cannot here (as they did in ancient Egypt) pass from Temple to temple through mighty stone Portals, therefore all we do is symbolically represent them, and these Three Portals are the three gates through which successively you will pass to attain any higher grades of this order. Remember therefore that to attain any higher grade or knowledge, always must you return to Malkuth. Whatever knowledge, whatever power you attain yourselves, in the world, though you attain to the very highest adeptship that ever yet was gained by man, the commencement is with your own body. Unless you can be lord of that you are a slave to it. Those Three Portals bear the Hebrew letters of Tau, Shin and Qoph. The purpose of these will be explained later as you study the Tree of Life though for the present remember that these three Hebrew letters make up the word *Quesheth* which means bow, the rainbow of promise. Therefore remember that when the king sits on the throne of the body, before him is the rainbow of promise. There are no heights to which he may not attain when that first step has been attained. In the 0=0 Grade you did not see these Portals which are now visible to you. In the 0=0 Grade you were only at the threshold, you looked upon the kingdom, as it were, which you were hereafter to conquer and rule, you now so promise.

Now symbolically you enter upon to commence to rule your body, so you see the rainbow of promise placed before you, which should be kept in your minds. On the Altar you will see the white triangle which again represents those paths which these Portals communicate, and the red cross is life and life within light, is upon the upper side of the altar.

One more point is shown to you in the first part of the 1=10 Grade, and that is the *Great Terrestrial Watch Tower* or the tablet of the North. At present it will probably be to all of you who are present, with the exception of those who have passed into the Second Order, an absolute sea of mystery. It appears a curious arrangement of squares and letters in different columns, and perhaps you may wonder to see the English and

not the Hebrew Letters upon it, seeing that it is one of the most ancient symbols known in the world. I may tell you, that without betraying any knowledge that is beyond you that these letters are simply transliterated for convenience. I do not think that anyone present in the Temple except myself who read the original language though I may tell you this, that it is a great curiosity, merely from a linguistic point of view, because there is no record of the original characters nor am I aware that this language was ever spoken or these characters used by mortal man. Now that Muller and other great philologists have said that it is impossible that any human being should invent a language, yet here is a language that has existed for as far back as we have been able to trace. One will be able to find traces of it on rock cut Pillars and on temples apparently as old as the world itself but we find no trace of it as ever having been used as a living language and we hold a tradition that it is the angelic *secret language*. Only one instance of this I may be allowed to give. The high priest of Jupiter in the early days of Rome was called *Flamen Dialis*. They will tell you that it is ancient Etruscan, but beyond that they can tell you nothing. It is not the generative of any nominative. On that tablet you will, *see* the second of the. Three Holy Names of God is Dial.

Now, that the tablet represents EARTH, the four tablets represent the Four Elements, and the names of the characters upon them are the key to the power ruling the Elements. They are not placed in the temple to be understood, they cannot be understood, but they do exercise an occult power that they operate, or rather I should say (because no dead thing ever could exercise occult power) they operate as the focus of the Will brought through the Inner Order, which is behind the officers working this temple.

The Fylfot cross represents, as you know, the twelve signs of the Zodiac, and if you look at it carefully you will find that the twelve *Signs are* arranged along the arms in their four Triplicities, and they are put, not in the form of the cross, which is stationary, but in the form of the Swastika, which represents whirlings. Therefore the FyWot Cross represents the whirling of

the wheel of the Zodiac around the earth, disposed in its four triplicities, related to the Four Elements, showing you that the Kingdom, the body which you have come to rule, is not a fixed and solid thing, but is in perpetual motion and it is those motions that you have to rule. You are not expected to find it always the same, but always different. Just as you find the Wheel of the Zodiac up in the heavens different every moment you look at it, so will you find the elements in your own body different at every moment. Sometimes the fiery elements will be uppermost, sometimes the Water, but whatever it is you carry in your hand, you carry the *Spirit* of the Immortal Emanation, from GOD Almighty for you carry the *whirling Elements* in your hand, and that is your badge of admission to our kingdom. Whatever way they whirl around you, which ever is uppermost, it may be Fire, Water, Earth or Air, no matter, you must rule it. You must carry in your hand and hold it any way you please as only you can be King of your own body.

Second Part

Now, if you have appreciated the symbology so far, the second portion may be very soon dealt with. You have learnt what your body is, what the Kingdom is that you have to enter to rule. Now you have to sit down upon the throne thereof, and the symbology is taken from the Temple of Jerusalem. As Saint Paul said: "Know ye that your bodies are the temple of the Holy Ghost?" In fact you are the Divine SPIRIT and Keeper of the Temple, pledged to God Almighty not to allow any profanation thereof, pledge to keep that temple pure and clean and fit for the habitation of the HOLY SPIRIT, whose Temple it is. Therefore you are taught now how to enter the Holy place as a priest of the temple. Hereto before as King you enter your Kingdom, now as a priest you enter the Holy Place of your Temple. Outside stood the *Altar of Burnt Offerings* whereon were sacrificed the various animals. What are these animals? All our evil and animal passions. Everything in our human body which we share with the animals, any desire to eat, to drink, or anything

else, must be sacrificed. That means not that the human needs of the body must be neglected. In olden times when these things were better understood, although animals were offered in sacrifice, animals were used in material things. Because the Jew of old offered oxen for burnt offering it did not prevent his ploughing the land with his oxen; he was commanded to do so. So all our material passions must be offered in sacrifice, but must also be made to subserve our material needs that we may rule them and not allow them to rule us.

Then purify with Fire and purify with Water; then again the Signs must be given. You must grope in your darkness and pledge yourselves to silence. You must recall the Divine interposer who admitted you to your and avow yourself to be an ornament of almighty. Then you may come once more to stand on the threshold of the Holy Palace, and pass through the threshold to the Holy Place in the sign of the Interposer.

Now then you see the *nature of the Throne* you have come to occupy. On the *North Side* was the *Table of Shewbread* and there were the twelve loaves upon it, which symbolised the Twelve Signs of the Zodiac, the Wheel of Life which is steady now because you now rule them, offered up on that table for GOD Almighty. And these Signs of the Zodiac refer to every part of the human body, from Aries which is the head, to Pisces which is the feet. Every Sign has its particular location in the human body; therefore the whole human body lies there upon the Table of Shewbread upon the North Side, offered up to the King of Kings. And on the South Side in the *Seven Branched Candle Stick*—the seven Planets, the Wanderers, the Wandering Lights, the Wandering Influences of MAN, which pass from Sign to Sign, from point to point in his body, his mind, his life, his dominating and governing principles, again all placed in the complete circle and offered up to the Lord who governs motion, and Lord of the North. He governs rest and darkness and silence—only two aspects of the one living God of Heaven. The Seven Planets, Seven Churches, Seven days of the Week, all mystic sevens that are symbolised by the Seven Branched Candle stick, the Seven Light Bearers, are offered here.

Then *Eastward* of you is the veil, which hides the holy of Holies from which the Priests of the temple have emerged, and from you which the glory of Hod shines upon you. And in front of the Temple veil stands the Altar of Incense hence the incense ascends like a prayer to the Throne of God, as you may imagine the Veil of the Holy of Holies stretched behind us here, and you may imagine our forms as those of Divine persons emerged from behind that Veil, or looking at your own body behind the SPIRIT of Prayer which is upon the Altar of Incense, the prayers which you offer to the Divine, you may imagine such manifestations as may be allowed you of the Divine SPIRIT, itself emerged from the Veil which shrouds the Holy of Holies from your Soul's gaze. Now, the Altar, as you are told, is black, but the Altar of Incense in the Temple of Solomon was gold. Why black? Because you are in Malkuth, because black is the colour of Earth, and as I told you, however high you rise you will have to come back to Malkuth always, and the body, the Malkuth of yourselves is a perishing body. Black is the colour of putrefaction, and death must result to this earthly body of ours, therefore is the Altar Black. And the Fire and the Water and the Incense are upon it. Receptive you must be as Water, energetic must you be as Fire, and your prayers like smoke of the incense must rise up to the Throne of God.

So you must learn from this to govern *your own body*. That is the first lesson which is taught to you. And as you proceed you will find that by and by that the same principle which enabled you to govern your own body enables you to obtain any knowledge you want, to produce and effect want to produce and the whole thing lies within the compass of this 1=10 Grade of which I can only give you the very faintest and simplest outline. I have told you nothing new, it is all in the ritual, but perhaps I may have succeeded in calling your attention to some things you may have passed over, because inattention is one of the greatest barriers that keep us from self development.

B1

Lectures and Addresses of the 1=10 Grade of Zelator Whare Ra temple

- 1. The 1=10 Ceremony**
- 2. The Rituals and How to Read Them**
- 3. Thinking Backwards**
- 4. The Hebrew Alphabet**

1

The 1=10 Ceremony

Self-Development, in some form or another, may be said to be that which we are seeking, that for which we are associated together. For unless we have some real and earnest purpose behind what we do, these Ceremonies are mere Burlesques and unworthy of our attention. But by joining the Order and attending its Ceremonies and undergoing its training, we hope to make ourselves better men and women than we were. We also hope to gain a further knowledge of the inner secrets of Nature, so that we may be able to use those powers of Nature whose existence we are conscious of, but whose modes of operation are hidden from materialism and which are therefore called "occult" In our, quest the Order helps in many ways. First of all, the Chiefs of the Temple, and to a lesser degree all Members of the Inner Order, can and do help occultly all members of the Outer Order from the Neophyte Oracle up to that of 44.

There is another way in which this Order helps you, and that is by its Ceremonies, and by the symbolism of its Ceremonies: that is what we are concerned with in this Lecture. As you grad-

ually come to understand the symbolism of Grade after Grade you will find that you are really learning formulae for your own development. Having learnt how to apply these formulae to yourself you can then apply them to the influencing for good of the outer world.

Remember that of the ten squares constituting the Cubical Altar in the center of the Temple only one and that the one on which it stands, represents the utmost part of the "material universe" of which you can have knowledge by what are termed the senses, and that, from the position of the Altar, is hidden. Therefore you are bidden, at the very beginning of this 1=10 Ceremony, to "enter the immeasurable region," to penetrate into the domain of the causes which lie beyond the material universe, to seek the concealed Majesty of GOD.

Now this Grade is referred to Malkuth, the Kingdom, the lowest of the Ten Sephiroth: it represents the material, the physical, the human constitution: It is your duty to enter into your Kingdom as a King, and there to sit enthroned as a King in his Kingdom: this is the lesson of the 1=10 Grade. The Kingdom is in fact the physical body, and the Kingship is the absolute control of this body. In ordinary life control of the body is necessary, but in the occult life it is far more so.

The outstanding feature of the first part of the Ceremony was your choice of one of the three pathways. That of "Good" may have seemed the natural one to have chosen, but it was barred for it is impossible to live the entirely spiritual life in the flesh. The true path, you were told finally, is the middle one, to live a true and upright life but not rejecting the material plane. Equilibrium, perfect control, is necessary before the King can really reign in his Kingdom. Remember the Hierophant's solemn warning:—"Except ADONAI builds the house their labour is but lost that build it." We of ourselves can do nothing.

The admission badge, the whirling Swastika, or Fylfot Cross, symbolically resumes this idea of control. The whirling of the Zodiac, disposed in four Triplicities, related to the four Elements, shows that the Kingdom, the body, which you have to rule, is not a fixed and solid thing but that it is in perpetual

motion. Whatever way it may whirl, whatever element may be uppermost in you, you must rule it: so only can you be King of your own body.

The second part of the Ceremony takes its symbology from the Temple at Jerusalem and carries this lesson of ruling the body a step further. As a King you entered your Kingdom, now as a Priest you enter the Holy Place. On the Altar of Burnt Offering are to be sacrificed our animal passions: but though offered in sacrifice they must be made to subserve our material needs so that we may rule them and not allow them to rule us. Then on the North side of the Holy Place was the Table of Shewbread. The twelve loaves are the Twelve Signs of the Zodiac and these again refer to the twelve parts of the human body: therefore the whole human body lies there offered up in sacrifice. On the South side was the Seven-branched Candlestick: the seven Planets or the seven senses. The whole of the symbology then points to the ruling of the Kingdom, the governing of the body. As you proceed you will find that the same principle which enabled you to govern your own body will enable you to obtain any knowledge you want, to produce any effect you want to produce: the whole thing lies within the compass of this 1=10 Grade.

One or two other points in connection with this 1=10 Ceremony may be noted. As the Grade is referred to Earth and deals with the physical body, therefore the Earth Spirits or Gnomes are invoked at the opening, and these may be seen by those who are clairvoyant during the Ceremony. Similarly at the subsequent Grades the other Elementals are invoked in turn. This is not for any idle display of magical power, far from it. By these Ceremonies the Elementals are definitely aided in their spiritual progress, so in addition to them helping us, we are helping them.

Then finally come to the "Three Portals." We are not able to do as they used to do in Ancient Egypt, pass from Temple to Temple through mighty stone portals. Therefore we symbolically represent them by the Hebrew Letters, and they are the gates through which you must pass to attain a higher Grade.

Remember that however high you attain you must always return to Malkuth. The commencement is within your own body: unless you are Lord of that you can be Lord of nothing. The Three Portals in the 1=10 are nOp, making the word Queseth, the Rainbow of Promise, Now, having entered the Kingdom which is to be conquered and ruled, you have before you the promise, and limitless is the height to which you may attain when once you have crossed the threshold. Again remember the warning:—"Except ADONAI build the house their labour is but lost that build it."

2

The Rituals and How to Read. Them

At the first hearing the Rituals of the Grades of the Outer Order may seem to some to be almost incomprehensible. It is certainly true; that it is necessary to be a Member of the Inner or Second Order before a full grasp of their meaning can be obtained. For one thing, these Ceremonies do not take place on the physical plane only, they have their counterpart on the higher planes, Inability to grasp their full significance at once should be a stimulus rather than a bar to the study of them, Taken singly or as a consecutive whole, the Rituals will be found to be a veritable mine of information and an inexhaustible source of inspiration.

It must be borne in mind that, although during these Ceremonies you may fail to understand much of what is going on and may be mentally fogged by being shown a number of what to you are meaningless diagrams, yet every action, every dia-

gram, has a definite effect upon your "sphere of Sensation," upon your aura, vivifying the symbols contained therein. This may not be noticeable to you at the time, but you will derive the benefit subsequently. These Rituals are intended to stimulate thought: they are full of tabloid information, camouflaged to a certain extent perhaps, if you like to use that term. But a prize which has to be striven for is valued more highly than an outright gift. Surface reading will yield but little: read and re-read, and come to the ceremonies to hear them read.

Before you have gone very far in your training you learn that "when rightly understood, the TREE OF LIFE is the key of all things." Consider, then, each Ritual in its relation to the Tree of Life: to which Sephira it refers. Consider also what Paths are trodden during the Ceremony, the admission badges and their symbolism and the general purport of the various diagrams which you are shown. Look up in a dictionary or elsewhere the various classical allusions: if a Mason, compare with Masonic degrees: in general, seek out all correspondences.

After generalities go through each Ritual, endeavouring to identify yourself with each officer in turn, In the opening part of the O=O Ritual the names of the Officers and the nature of their Offices is set forth at length. Ascertain therefore how in each Ceremony the Officers do carry out the functions attributed to them: consider each officer's actions as well as words—the effect which they would have on you as that officer and also their relation to the candidate, Finally identify yourself with the candidate. Ponder on what he experiences when hoodwinked, and then what he experiences when the symbol of blindness is removed—and this right through the Ceremony. What influence should each Ceremony have upon the Candidate, and what symbols should be vivified in his sphere of sensation? Naturally to do this thoroughly will take time, but nothing worthwhile is ever attained without effort. If the Rituals are conscientiously studied, the taking of an Office at a Ceremony, instead of being a case for nervous prostration, will be a joy and a privilege and the subsequent writing of a thesis upon the Outer Rituals (a thing expected later on of all candidates) will not be the cause of confusion.

3

Thinking Backwards

'Thinking backwards' is a piece of training that will assist you in many ways; will strengthen your mind, memory and will-power.

Every night for a few minutes before retiring to bed, make yourself comfortable in an easy chair, with your back to the North and with your feet warm. Then start thinking backward right through the day, taking incident by incident in order until you reach the time when you awoke in the morning. Don't go into too much detail at first: let the day pass before you as a cinematograph film, the incidents etc. taking place in the reverse order to that in which they actually occurred. With practice you will be able to go back through several days, then weeks, and finally years; it needs no imagination to see the value of being able to recall what you are doing or saying at any past time.

Eight hours out of every twenty-four, for one third of your life, you are asleep and normally do not know what you are doing. During that time your subconscious self is looking after your

body helping it to recuperate. Having done this, the subconscious self goes and meets the *Higher Self*, transferring to it the sum total of the day's events, thus you are constantly character building outside yourself, If you train yourself to think backwards the time will come when you will be able to ascertain what you were doing ere you awoke, to have knowledge of the subconscious life during sleep when the subconscious self is not in the body. Finally you may learn of your last and previous lives, of when you made your first choice of incarnation.

There is a Trinity above and below: before you entered this world you were three points in a circle, At birth two of these incarnated in the physical body prepared for you—your mind and your subconscious mind, The other point, your Higher Self, stayed outside, connected with the physical body by a very thin attenuated line of etheric substance. The base line of a triangle is made between the brain or waking consciousness and the subconscious self. During sleep the subconscious self is in contact with the Higher Self, forming the base and one side of the triangle. The third side of the triangle we formulate for you at the 0=0. In time you may be able to draw down your Higher Self to converse with you, and so find out whence you came, why you are here at all, and what your real object in this life is. Surely it is worthwhile to find this out, to have a certainty, rather than a pious hope or idea, as to the past, present, and may be the future too, if GOD wills.

4

The Hebrew Alphabet

by M.C. (Mrs. R. W. Felkin)

In giving our students the Hebrew Alphabet to study we are taking them back to the foundations of the intellectual tradition of the present day. To understand this it is necessary for us to glance back to the beginning of human history. We have reason to believe that humanity in its present form was evolved on the antediluvian continent of Atlantis and that at the submergence of this continent offshoots of their civilization survived in those races which we know as the Egyptian, the Caucasian and the Celtic. There were also the forerunners of the Mongolian. Here, then, we have those primitive races who first reduced the spoken word to the written symbol. Celtic origins are still veiled in obscurity, but the remaining three reveal themselves to the patient investigation of the archaeologist and etymologist as unbroken streams descending and branching out into the languages of today. With Mongolian tongues we have no concern, they are alien alike in sound, construction and written form. But from the Sanskrit of the Caucasian and the Egyptian are derived the modern tongues of the greater part of the present civilisation.

There can be but little doubt that when the wandering tribes of the Hebrews first settled in Egypt they had practically no written language. They spent, we are told, 400 years in the land of Goshen, that is approximately as long *as* from the time of Queen Elizabeth to the present day! When they first settled in the land of Goshen on the Eastern side of the Nile there were 70 people, including women and children. When they fled, four centuries later, their number is said to have been over six hundred thousand. It is reasonable to conclude that in the interval, although they remained separate from the natives of the country, yet they imbibed most of their customs and as much as possible of their language and learning. Moses, their leader, was brought up by the priests and initiated into their mysteries. He was familiar with their system of hieroglyphics and there can be but little doubt that when he set himself the stupendous task of recording the history of Israel he availed himself of both the form of writing and much of the cosmogony which he had acquired in his temple training. By this means he was enabled to preserve the inner tradition while at the same time presenting an exoteric history. For it is the peculiarity of the genius of both Egyptian Hieroglyphics and of the Hebrew writing that it is capable of a three-fold interpretation, literal, symbolic and spiritual.

In studying the actual letters as we now possess them we must of course admit that they have undergone a considerable modification since the days of Moses, the most important being their approximation to the Chaldean owing to the exile. From the Chaldean also was borrowed the vocalisation system by means of points placed above, below, or within a letter. Nevertheless the hieroglyphic idea is retained in that each letter represents not merely a sound, but also an object, and the name of the letter *is* also the name of the object, hence the list which you were given in the First Knowledge Lecture. That is to say—ALEPH (Arabic, ALIF) not only means the letter A or E (or more accurately, the opening of the mouth to make a sound), it is also the name of an ox. The word BETH is not only the letter B or V, but it is also the name of *a* house.

There is another thing you have to bear in mind. In all the ancient languages there was only one system of notation for both sound and number. Therefore each letter is also a number and each word has a numerical value equal to the sum of its numbers. Thus **שן** is not only a sound EL or AL, and a Divine Name, it is also 30 plus 1= 31.

Moreover a language like Hebrew had comparatively few words, but each word had numerous shades of meaning indicated either by the context or by the inflection and also each individual letter had its own essential meaning: therefore it follows that the word was the sum of or modification of those meanings, just as numerically it was the sum of those individual numbers. Thus **שן** which signifies the number 31, is formed from **ן** the sign of power and from **ש** the sign of extension. Its spiritual meaning is therefore Extended Power, and hence GOD, the Power extended over all. Used in a restricted or materialised sense it may be translated as towards, against, upon. The same letters reversed **נס** represent spiritually the prolongation of movement to infinity, which translated upon a lower plane becomes a negative and may be rendered as no, not.

Let us now consider the abstract symbolism of each of these letters.

ן is the sign of power, stability, unity. It represents mankind as ruler of the earth. ALEPH = an ox.

ב is interior action. It represents virility, and an interior, a dwelling place. BETH = a house. Unite these two and you have **בן** or **באב**, a father.

ג is the sign of organic development, hence the throat, or a canal which organises or controls inflexion of sound, a glass of water. GIMEL = a camel.

ד is the sign of abundance from division, divisible nature, the source of physical existence: the breast, source of nourishment. The word DALETH signifies a door, the entrance or exit.

ה This letter merits special attention. It is the symbol of Universal Life, the breath. It be translated as either E or H and is

closely akin to ה in meaning as well as form. It is frequently used as an article, and may be translated as the, this, that, of. In this aspect it is used as a prefix or as an affix. It forms when united with a vowel sound the principal Deity Names and in this aspect it indicates an abstraction which no modern language can render adequately. Thus הִי is Absolute Life, Eternal, Immutable. הַיְיָ can only be adumbrated as That Which Is—Was—Will be. It is the root of the verb הָבָה, to exist, and is used to denote the source of human life in the Name הִיָּהּ which we translate as EVE, but which also may be given as HUA the third person singular of the verb To Be, or simply as HE. When the significant is added it becomes Tetragrammaton הַיְיָ the Inviolable Name which must not be taken in vain and which was only intoned by the High Priest upon entering the Holy of Holies. Even today no orthodox Jew attempts to utter it.

ו This letter is equivalent to O, U or V. It is therefore convenient to use the point to indicate the sound since its symbolism differs widely according to its pronunciation. As a V ו is used as a conjunction and is placed at the beginning of a word; it may be translated as and, also, thus, then, afterwards; but it links words together more intimately than any of these. Used as a vowel, ו = O, ו = U or OU, it is then a sign of action and has the peculiarity of transforming a verb from the present to the past or from the past to the future. In these aspects it no longer represents the junction of two things (as an hook and an eye, a knot, a link), rather it is the symbol of light, sound, air, wind. Hence הַוַּי the wind, breath or soul, because ו movement, הַיְיָ life, and ו in the midst gives the peculiar human character to the word which indicates expansion, inspiration.

ז The hissing sound of something passing through the air, hence a sword or arrow, a javelin or spear. It also denotes the refraction of light, suggesting the dazzling appearance of a ray of light falling on polished metal. It may be transliterated as Z, C or S.

ח This letter is closely allied to ה both in form and in significance; but as it is more closed in form so it is more guttural

in sound and of a material connotation. It signifies life, but on a lower plane. It implies effort, labour, care. Thus in concrete example it indicates a field, an enclosure upon which labour must be expended.

𐤁 hieroglyphically shows the coiled serpent protecting her eggs, hence the universal tradition of the serpent guarding treasure. From that we get the idea of a shield, shelter, a roof protecting man's family as the serpent protects her eggs. Finally a haven, refuge or goal.

𐤂 Here we come to another profound symbol of deep significance. The hieroglyphic interpretation is that of the hand. But it is a hand held out in action, thus it is the symbol of, creation. It is the symbol of a flame detached from any material base, free, the leaping creative impulse. By a natural transition we get the phallic symbol of creative power. On the abstract spiritual plane we have the Divine Creator. Thus this letter transmutes 𐤁𐤁 the feminine source of life, into 𐤁𐤁𐤂, the Ineffable Supreme.

𐤃 Hieroglyphically this represents the closed or half-closed hand, a fist; hence a hollow, therefore a receptacle: the power of assimilation, reflection, meditation. It forms a link between 𐤁 the sign of manifest life and 𐤂 the sign of organisation, and carries in itself something of the symbolism of both these. Used as an article or preposition it may be translated as similar, according to. Vocalised by 𐤂 it signifies and 𐤂𐤃 because, for, then, when.

𐤄 In a material sense this suggests any extension, the outstretched arm of man, the unfolded wing of a bird, hence the further symbolism of the whip lash or ox-goad. But when these interpretations are raised to the spiritual plane we perceive at once how significant this letter becomes. 𐤄𐤁 therefore, represents an Extension of Power, omnipotence. Hence 𐤄𐤁𐤂 is the Extension of the Power of Life to the nth degree, that aspect of the Divine which is capable of creating without effort. Conversely 𐤄𐤂, signifies an indefinite and therefore unknown and

incalculable quantity, which brought down from the abstract to the concrete becomes negation, no, not.

𐤁 The sign of plastic or passive action; the genuine protective aspect of creative power. Hence vocalised as 𐤁𐤍 it signifies water, always used in the plural since the final MEM is collective *as* water is the condensation of moisture. With the letter 𐤅 prefixed we get 𐤁𐤍𐤅, the Heavens, the ethereal water or atmosphere. Used as an article or prefix 𐤁 may be rendered *as* from, out of, with, among. Hieroglyphically we may *say* that 𐤁 indicates rough water, sea waves, while 𐤁 *final* suggests rather still, calm water.

𐤂 This letter is the image of produced or reflected existence, offspring, fruit, a child; hence it represents hieroglyphically a fish, the inhabitant of water. Joined to 𐤁 the sign of interior action, it becomes 𐤁𐤂 son. This is more clearly defined when we realise that 𐤂 final is augmentative and emphasises the individuality. 𐤂 at the beginning of a word suggests passive action, contemplation folded in upon itself: 𐤂 at the end is the converse, unfolding. Thus 𐤁𐤂 represents inspiration, prophecy, ecstasy. From this is derived 𐤁𐤂𐤍 a prophet.

𐤃 As it presents the development of the hissing sound of 𐤅, so hieroglyphically it is the duplication, the duplicate link forms a prop, not merely joining but supporting. It is the image of all circular and spiral movement, possibly a deduction from the peculiar movement of the serpent.

𐤄 Hieroglyphically this letter signifies an eye and here we find one of the most curious and erudite survivals of occult knowledge. Superficially there seems to be but little likeness between the letter and the symbol. When we come to consider it more carefully we find that it is indeed an extraordinary glyph of the organs of vision. Externally we have the two eyes " " but inside our head lies a small body, one (or rather two closely connected) of the so-called "ductless glands" of modern physiology—the pineal and the pituitary glands. These glands are connected with the external eyes by delicate nerves, and when the external eyes are exercised in certain methods they awake

הַתְּלִמָּה, the vortex, the beginning of primeval movement, the Sphere of the Elements. It is the centre unfolding to the circumference, the creative elemental fire: the renewal of all by movement; the perpetual vibrations of ions building up matter. Hence **אֵשׁ**, fire, action, contrasted with **שֶׁשׁ**, potential fire.

שׁ is said to represent the teeth, by which its sound is produced. It completes the symbolism of **ו** and **ב** and is in a sense bound to them, for as **ו** = the arrow and **ב** = the bowstring so **שׁ** symbolises the bow itself; hence we are told that the Three Paths on the Tree of Life form **קַשׁוּב**, the Bow, the material sign of reciprocity between God and man. **שׁ** is the symbol of movement and duration, Used as a prefix it communicates a double power of movement and of conjunction. It may be pronounced either SS or as SH and it usually has a point above it to indicate which sound is to be used, **שׂ** = SS and **שׁ** = SH. Geometrically it represents the semi-arc of circle, whereas **ו** is the straight forward movement of a radius and **ב** a spiral. By analysis we find that the Divine Name **שׁוּב** represents the Overarching Heavens protecting the fecundity and abundance of Nature—hence Providence.

ת The last letter of the Hebrew Alphabet, is a glyph of the Cross, the name being still retained to indicate the ancient form of Cross—the Tau T, sacred to THOOTH. It is probable indeed, that the letter was originally written thus and gradually elaborated to distinguish it from **ו**. It is the sign of reciprocity, of that which is mutual, interchanging, sympathetic. Joined to the first letter of the alphabet it indicates **תּוֹב**, the essence, the inmost self of a thing or a person, and in this form it is repeatedly used by Moses as a prefix in his account of Creation to indicate that he is not describing a material or individual, but an essential process which developed on a higher plane preliminary to any physical manifestation.

In analysing the various Names that occur in the Knowledge Lectures and elsewhere, it must be remembered that each letter modifies as well as emphasises the others; that the meaning of the whole word is the combination, not the simple addition of its

constituents. But an intelligent appreciation of the wonderful symbolism contained in the 22 Letters of the Alphabet will go far towards helping us to gain an insight not only into the Hebrew but also into all other languages, since every superstructure must conform to its foundations. I may add that each letter has also been attributed to a portion of the human body, but as Astrology has accepted this system with regard to the Zodiacal and Planetary Signs it is better not to confuse the issues by dwelling upon this classification. Rather let us conclude with the saying of the Rabbi—"In the Beginning GOD took the 22 Letters, and with them He formed, combined, and designed all that was made."

The Second Knowledge Lecture

Whare Ra Temple

The three Principles of Nature as addressed to their Alchemical aspects are:

Sulphur
♁

Mercury
☿

Salt
⊖

The Metals attributed to the Planets are:

Lead ♃

Iron ♂

Gold ☉

Copper/Brass ♀

Quicksilver ☿

Silver ♃

SOL PHILOSOPHORUM: The Pure Living Alchemical Spirit of Gold; the refined essence of Heat and Fire.

LUNA PHILOSOPHORUM: The Pure Living Alchemical Spirit of Silver; the refined essence of Heat and Moisture.

GREEN LION: The Stem and Root of the Radical essence of Metals.

BLACK DRAGON: Death—Putrefaction—Decay.

KING: Red—The Qabalistic Microprosopus.

Tiphareth—analogous to Gold and the Sun.

QUEEN: White—The Qabalistic Bride of the Microprosopus.

Malkuth—analogous to Silver and the Moon.

THE FOUR ORDERS OF THE ELEMENTALS ARE:

- | | |
|---------------------|-------------|
| 1. Spirits of Earth | GNOMES |
| 2. Spirits of Air | SYLPHS |
| 3. Spirits of Water | UNDINES |
| 4. Spirits of Fire | SALAMANDERS |

These are the Essential Spiritual Beings called upon to praise GOD in the "Benedicite Omnia Opera."

The KERUBIM are the Living Powers of Tetragrammaton on the Material Plane and the presidents of the Four material Elements. They operate through the Fixed or Kerubic Signs of the Zodiac and are thus symbolized and attributed

Kerub of Air	Man	Aquarius	♒
Kerub of Fire	Lion	Leo	♌
Kerub of Earth	Bull	Taurus	♉
Kerub of Water	Eagle	Scorpio	♏

TETRAGRAMMATON means Four-Lettered Name and refers to the Unpronounceable Name of God symbolised by Jehovah.

THE LAVER OF WATER OF PURIFICATION refers to the Waters of Binah, the Female Power reflected in the Waters of Creation.

THE ALTAR OF BURNT OFFERING for the sacrifice of animals symbolises the Qlipoth of Evil demons of the Plane contiguous to and below the Material Universe. It points out that our passions should be sacrificed.

THE QLIPOTH are the Evil Demons of Matter and Shells of the Dead.

THE ALTAR OF INCENSE in the Tabernacle was overlaid with Gold. Ours is black to symbolise our work which is to separate the Philosophic Gold from the Black Dragon of Matter.

The Altar Diagram shows the Ten Sephiroth with all the connecting Paths numbered and lettered, and the serpent winding over each Path. Around each Sephirah are written the names of the Deity, Archangel, and Angelic Host attributed to it. The twenty-two Paths are bound together by the serpent of Wisdom. It unites the Paths but does not touch any of the Sephiroth, which are linked by the Flaming Sword. The Flaming Sword is formed by the natural order of the Tree of Life. It resembles a Lightning Flash.

The Two Pillars on the side of the Altar represent:

ACTIVE—WHITE PILLAR ON SOUTH SIDE.

Male.

Adam.

Pillar of Light and Fire.

Right Kerub.

Metatron.

PASSIVE—BLACK PILLAR ON NORTH SIDE.

Female.

Eve.

Pillar of Cloud.

Left Kerub.

Sandalphon.

THE FOUR WORLDS OF THE QABALAH ARE:

Atziluth, Archetypal—Pure Deity.

Briah, Creative—Archangelic.

Yetzirah, Formative—Angelic.

Assiah, Action—Matter, Man, Shells, Demons.

The Ten Houses, or Heavens of Assiah, the Material World are:

1. Primum Mobile, Rashith ha-Gilgalim.
2. Sphere of the Zodiac, **Mazloth.**
3. **Sphere of Saturn, Shabbathai.**
4. **Sphere of Jupiter, Tzedek.**

5. Sphere of Mars, Madim.
6. Sphere of Sol, Shemesh.
7. Sphere of Venus, Nogah.
8. Sphere of Mercury, Kokab.
9. Sphere of Luna, Levanah.
10. Sphere of the Elements, Olam Yesodoth.

The traditional Tarot consists of a pack of 78 cards made up of four suits of 14 cards each, together with 22 Trumps, or Major Arcana, which tell the story of the Soul. Each suit will consist of ten numbered cards, as in the modern playing cards, but there are four instead of three honours: King or Knight, Queen, Prince or King, Princess or Knave.

The Four Suits are:

1. Wands or Scepters comparable to Diamonds.
2. Cups or Chalices comparable to Hearts.
3. Swords comparable to Spades.
4. Disks or Coins comparable to Clubs.

Evil

by A.M.M. (R.W. Felkin)

I can remember quite well, about 28 years ago, going through this 1=10 ceremony myself. Then I think was the first time I ever realised what Evil was, and how thankful I was for it. I want you to get hold of the idea of Evil as opposing forces.

This 1=10 ceremony shows you three paths, either of which you might have chosen had you been left to yourself, these two paths being that of Good and Evil. A better road, the straight and narrow one, is ultimately pointed out to you as the one to be followed.

Now it is absolutely essential to have opponents to struggle against in order to develop a balanced nature. Think of life in that way and you will get much help. If it had not been for all the evil of the years of the war there would not have been the same chance for the materialization of all the good that which was developed and shown by those who were fighting and by those who were helping in other ways. Evil then is an opposing force which helps us towards the attainment of a balanced nature, and by overcoming that force we develop the opposite quality.

Before the candidate enters the temple for this ceremony the Spirits of Earth are invoked and near the Northern Tablet are the Elemental Gnomes. They are working for the world, and it is our privilege to help them to a higher degree of Spiritual power and utility; they too are struggling and striving for perfection, and in our ceremony we do aid them in their progress. In subsequent ceremonies you will come across the other Elementals in a similar way.

Remember, then, this is the Earth Grade, resembling the physical body, bones and muscles. It also shows you that a sound basis is necessary for the perfect development of a temple for the Holy Spirit; your object and duty is to accomplish this *as far as possible*.

After each ceremony, take and study the ritual, for it contains so much that it would take literally *weeks* of study to really grasp the whole of the cosmic knowledge and teaching in it. In all sacred scriptures the words themselves are only the *garment*: get behind the text and study and meditate and really penetrate what really lies behind. We know that the Bible tells us that the creation was accomplished in six days, in a week that is, and the dates given in the margin tell us that this took place not many thousands of years ago. Yet we know from geology and from other sources that the earth is five or six thousand million years old; instead of "days" we must therefore understand years or long eras of time. One of these great eras is now coming to an end, and the next begins when the Sun enters the Sign of Aquarius.

Since the disturbing influence of the Great War, as well as before it, there has been industrial unrest, all manners of striving and general wonderment as to what will happen next. An increase of spiritual power must come and descend upon the world: these are the Signs of the times. You will realise therefore the responsibility which rests upon you is very great, for you have your part to play in the reconstruction of the world. You have knowledge to spread, not that it means revealing of Order Secrets, but so altering your lives and aspirations in the light of what you are learning, you will be able to do good to all

with whom you may come into contact.

Whose fault is all the present industrial unrest? People do not realise that there must be give and take on both sides: and so it is in everything connected with this life, this is the only way of progress. Cultivate the balanced nature and let each do what he or she can towards spreading this idea amongst them.

Symbology of the Gate

by M.C. (Mrs. Felkin)

You will notice that in this grade the Symbology of the Gate is constantly used: it is one of the most interesting and wonderful symbols in life, and as you study the rituals of the Order you will see that they are founded upon the Tree of Life, the Ten Sephiroth being joined by the twenty two paths, and in each grade there is a gateway to a higher stage or plane. We are told that our first parents were driven out of the gate of Eden, that is from the Higher plane to the Material plane, their coats of skin symbolising their physical bodies. Each of us must of necessity seek that gate in order to return whence we came.

As we pass along the road of life, we see many gates, which we want to open and look over, but we must be on our guard lest we follow the path of evil. There is a form of Black Magic which maintains that the only way of arriving at true knowledge is to tread the Path of Evil. But our system of White Magic teaches its pupils that only he who passes through the gate with clean life and pure heart can obtain his quest, and it is only with clean hands that he can lift the Grail.

You are told during the ceremony "to tread the pathway of Light," but that is barred, for it is impossible to live the entirely spiritual life in the flesh. The true path then is in the middle way; to live a true and upright life, not rejecting the Material plane.

This is not only the Gate through which we can pass, but there is always an elder brother waiting to help, which is one the functions of an *elder* brother. The word "priest" means "elder Brother" and one of his functions is to open the gateway; and we are told that we are all lay-priests and kings, all initiates must be ready to open to those that come after. Then the time will come when the Great elder brother will open the gates for us to meet HIM. That is the gate which David speaks of when he says "Lift up your heads O ye gates and the King of Glory shall come in." Thus shall we also be admitted to the Kingdom of God.

B2
Lectures and Addresses
for the 1=10 Grade

1. Ancient Egyptian Religion (by M.C.)
2. How to Read the Scriptures (by M.C.)
3. The 12 Tribes and Their Relation to the Zodiac
(by MacGregor Mathers)

1

Ancient Egyptian Religion

by M.C. (Mrs. Felkin)

Of all the ancient religions, that of Egypt strictly concerns us. When the Hebrews went into Egypt, they were a small tribe with a strong family feeling; a clan, the Scotch would have called it. They were struggling towards the ideal of an overruling Providence who had set them apart from the rest of the world. They were nomads with little knowledge of learning beyond their skill in breeding cattle, but they had extraordinary tenacity and vitality and a well marked "Psychic" faculty. Two hundred years later they emerged a nation, wielded together by persecution, led by a man who had been trained in the Universities of the day, a man who could not only give the moral code which has proved to be the foundation of law and order ever since, but also a cosmological philosophy unsurpassed by any, and a sanitary and hygienic system which bears comparison with most modern.

Where did these leaders acquire their enlightenment? Moses was visionary, an idealist, but he was also an eminently practical man. He had been brought up at the Egyptian Court,

trained in the college of the Egyptian priests, and by the age of forty he had passed all their severest tests and had become what is termed an Initiate. What is an initiate? Briefly, it is one who has passed beyond belief into a wider realm of knowledge. You believe what others tell you: you know only by intimate personal experience.

Thanks to the Egyptian habit of inscribing their history and doctrines on stone walls and parchment scrolls, we are now in a position to study a great deal of this "wisdom of the Egyptians" in which Moses was learned. Not all of it, however, for we know that the highest degree of teachings was always given orally, but enough remains to show us an extraordinarily profound and comprehensive religion and philosophy. All religions have two sides, the exterior which appeals to the majority, and the interior which is grasped by the few only, and this characteristic is strongly present among the Egyptians. For the majority there were many Gods under various forms and appellations; for the few there was the One, Eternal, Incomprehensible, manifesting in the threefold aspect of Father, Mother and Child.

Before we go further, I want you for a moment to consider the geographical position of Egypt. If you look at a map of the northern part of Africa you will see the Nile rising above the mountains and flowing northwards to the Delta. Along its shores is a strip of wonderfully fertile land, irrigated naturally by the annual rise of the waters, owing to conditions in the far off mountains: beyond that fertile strip lies the desert. That long narrow strip of irrigated land is Egypt. It has two great divisions, North and South, which in early times had separate kings: later on they were joined and Pharaoh received the title of King of the North and South and assumed the double crown with which frescoes and statues have made us familiar. But besides the two great divisions there were innumerable lesser ones called by names which correspond roughly to our countries. Each had its own capital, its own temple, and its own governor: more so, each one had its own peculiarly sacred animal which was preserved in the temple precincts, considered strictly

"tapu"* by the inhabitants and mummified after death. It does not follow that the animal in itself was regarded as divine, but it was certainly considered symbolic of some attribute of divinity. Let us take for instance the animal with which we are all familiar, the cat. What are the peculiar qualities that the cat shares with its bigger cousins, the lion and the leopard? Remember that both these animals abounded in the deserts abutting Egypt. The Egyptian cat was, and is, a big, fierce, many coloured creature: its colour blends in with the desert and suggests the burning heat, the destructive force of the sun: it was a beast of prey, impossible, insatiate. So on one hand it typified all the forces of Fate, Visham or Karma. But the cat has other marked characteristics: physically it has the curious faculty of seeing in the dark: the pupils of its eyes contract to mere slits at noonday or in strong light; they expand to the whole width of the iris at night or in darkness. Therefore its eyes symbolise the moon which waxes and wanes. Moreover the cat is pro-life and a devoted mother: she will face any danger in the defence of her kittens, and she is also capable of great friendship with and devotion to human beings. So in this aspect she symbolises maternity, protection, womanhood. Under the one aspect she was dedicated to the lion-headed Goddess Sekhah, and under the other to Pasht, the Mother. The Temple of Bubastis was her special home and there innumerable tame cats were kept and regarded as sacred. It was a crime to kill one of them and when they died they were mummified and given all funeral honours.

So it was with each home: each had its own sacred animal, but in the process of time some of these animals were established as sacred throughout the whole kingdom. The hippopotamus and the vulture, like the cat, symbolise maternity. The ram and the bull represent the male principle and the scarabaeus beetle was sacred to the creator of the world. This gives us a curious little sidelight on the extent and the accuracy of the sci-

*This is a Maori word which is analogous to "taboo."

entific knowledge amongst the priests. The scarabaeus has the peculiar habit of laying its eggs in suitable material which it then rolls into pellets about the size and shape of a pea. Then it proceeds to roll along, pushing them with its head, assisted by its front legs, and using its hind to walk with. The pellet was taken as a symbol of the world, but a symbol must resemble that which it symbolises, and therefore it became evident that these ancient Egyptians knew that the world was round, not flat. Naturally enough the uneducated people identify the sacred animals with those Gods whom they were associated with, and as Egypt was invaded and conquered repeatedly by successive warriors who all brought their own Gods, which were added to those already accepted, there accumulated an enormous Pantheon: but Egypt had a characteristic in common with Britain: however varied her conquerors, they were all absorbed into herself until they too became Egyptian. Each Pharaoh in turn found that the only way to govern the country was to accept its traditions and teachings. His sons were trained by the priests and became in due course head, not only of State, but also of the religion.

From the confusion of animal Gods we penetrate by degree to a remarkable clear and rational cosmic religion, the inner teachings which lay behind all the rest. First, and beyond all, was the Supreme, Unmanifested, Ineffable--Amon. Today we retain this mysterious name in Amen, with which we conclude both prayer and praise. By His command both heaven and earth came forth into being, and from their union issued five Gods, Osiris, Isis, Set, Nephthys and Anubis. The first three correspond to the Hindu Trinity, Osiris the Creator, Isis the Preserver, Set the Destroyer. Of the remaining two, Nephthys represents the passive aspect of the Feminine, while Anubis is at once the guardian of the sanctity of the Gods and the guide who leads those who earnestly seek after divine things. No doubt some of you are familiar with the story of Osiris and Isis, but I will repeat it for those who have not heard it.

Osiris and Isis descended to earth to live as King and Queen over Egypt and to teach the people the peaceful arts of agricul-

tune. They showed them how to cultivate their fertile land and how to grow crops, especially wheat, and how to irrigate. The country flourished and the people prospered under their beneficent rule: it was a Golden Age. But after a time Osiris set forth on a journey in order to teach these arts to other people, leaving Isis as regent during his absence. No sooner than he was safely gone than his brother Set came upon the scene. He avowed friendship with Isis and gathered a party of the nobles about him and awaited the return of Osiris. In the meantime he gave orders for the construction of an elaborate and very beautiful coffin; that is, the outer shell a mummy is laid in before being put in the great stone sarcophagus. You know that the Egyptians paid a great deal of attention to all that pertains to death: the Pharaohs and priestesses especially had very wonderful mausoleums and coffins prepared during their lifetimes, elaborately painted, recording the story of their lives on earth and also their progress after death. Set then, no doubt, had an exceptionally beautiful coffin made. When at length his brother returned, Set took a foremost part in the rejoicing and gave a great feat in his honour.

During the feast the new coffin was produced and Set offered it as a gift to whomsoever it would fit. One after the other laid down in it, but for each it was too big or too small, for it had been made from the measurements of Osiris. At last he in turn lay down in it and immediately Set and his confederates shut down the lid securely and poured boiling lead through the holes which had been pierced in it. So Osiris died and they set him adrift in the great river which carried him away until the coffin was caught in the branches of a tree which had been submerged by flood.

Meanwhile, Isis discovered Set's treachery, for he had seized the Kingdom and would have taken her also had she not fled. For a long time she wandered to and fro in search of her husband: it was her tears falling on the bosom of the Nile which caused it to rise in flood and thereby prevent the coffin from drifting out to sea.

At last, after many adventures, she found and recovered the

body of Osiris and carried it to a hiding place in the papyrus swamps. There by the power of her love she recalled Osiris to momentary life, and from that recall was afterwards born Horus. But Osiris again lay in her arms and Isis set forth to collect the oils and spices with which to embalm him. In her absence, Set found the body and this time he tore it asunder in fourteen pieces which he caused to be scattered over the whole country. So when Isis returned she had again to set forth on her tragic quest. In the process of time she found the fragments, and on each place hallowed by the fragments of a relic she had a temple built. When Horus was born, her sister Nephthys helped to nurse him and then he was brought up with great care and was trained so that in due time he might avenge his father's death. He met and challenged Set and they fought a great battle, but in the end Set escaped in the form of a crocodile.

Here we have an allegorical history of the human race shown forth. The descent of the Initiate, his teachings and illumination followed eagerly for a time. The powers of evil entice man from his allegiance: the death and disappearance of the Initiate rescued from oblivion by the devotion of love: the survival of Light and subsequent struggle between Light and Darkness.

The Egyptians believed in the resurrection in a dual sense. A man rose again upon the earth in his children, but his spirit passed on to a spiritual world. They believed in a personal judgement after death: each man must stand before the judgement seat of Osiris who reviewed his deeds and awarded his judgement. The part of the recording angel seems to have fallen to Anubis, who was also guardian of the Sanctuary. If a person failed to pass the required tests he was turned back and sent to the level of the beasts. If he were passed, then Isis and Nephthys led him past the judgement house and he became one of the company of Gods, he became "Osirified." He must *pass* through the region which corresponds to purgatory and thence he rose through the planes of Light. The spirit was represented in hieroglyphics and frescoes as a bird hovering with outstretched wings, ready to soar.

2

Reading of the Scriptures

by M.C. (Mrs. Felkin)

In studying the great scriptures of the world, we very soon find that there are at least four ways in which they may be approached:

1. They may be taken literally at their face value—a method which we find was almost universally accepted in the 19th century as regards the Bible, when we find even in regard to translation, "verbal inspiration," the shibboleth of a considerable number of those who call themselves the educated classes.

2. There is the opposite extreme to this, the practice of regrading them more or less *as a* haphazard collection of folklore and stories suitable for children, of value to men chiefly as indications of persistence of traditions. The leaders of this school wasted a vast amount of energy who tried to prove that the books were not written by the men whose names they bore, or in trying to prove that the scriptures (we use the name to denote sacred writings of all nations—the Vedas, Koran, the Egyptian Book of the Dead, Hebrew Scriptures and all the

myths of Scandinavia, Greece and elsewhere) are originally either totemistic or else purely nature allegories.

3. There is a small but conservative group of those who seek to give a purely spiritual interpretation, maintaining that there is no historical basis at all for the various stories and traditions enshrined in these books.

4. Lastly, there is the steadily increasing school of occultists, to which we ourselves belong.

If the true occultist there is always a material basis which contains the key to the spiritual truth. So that the occultists will believe that any scripture worthy of the name must be regarded from all these points of view if the reader is to penetrate to its real message. Since we are chiefly concerned with Hebrew Scriptures, to which we accorded par excellence the title of the Holy Bible, we will conform our attention to that.

The Bible, then, must be regarded in the first place as an historical record, dealing for the most part with the rise and preservation of a small Semitic race who possessed certain strongly marked characteristics. In the second place, this history is dealt with in such a manner that it contains an almost unbroken parallel with the great cosmic phenomena observed and recorded by those occultists who were the forerunners of modern science: and thirdly, these records contain within them the stupendous drama of the human soul. Take any point of the Bible, haphazard and, if you have eyes to see and a heart to understand, you will find therein the story of God's dealing with man—man as an individual or as a human race.

We as members of a Secret Order that has existed for centuries, have this advantage over most of those who seek to interpret this extraordinary document. We start out with a hypothesis that a secret tradition has existed from time immemorial; that is, has been preserved by means of Occult Orders such as our own, and much of its teaching has been handed on by oral tradition and conveyed by means of ceremonial.

We are taught that humanity is the child of union between

animal and spirit, that our bodies are the logical product of age-long evolution, which is recorded in the Book of Genesis, the Book of Beginnings. Bearing in mind that this is a condensed, but unintelligible account of evolution. What do we find? "In the beginning" it says there was a Divine Intelligence which the human brain can only vaguely conceive. The Qabbalists named it the "AIN SOPH AUR"—Limitless Light; another title is the "Negative Existence" or we can speak of "Potential Energy" This energy manifested in that form which Kelvin postulated as "vortices"—there was a movement, but without form. But movement produces form, and therefore in the course of Aeons worlds were born, and as further aeons passed by, these worlds became differentiated and clothed. Remember that to the occultist there *is* no such thing as death; matter may change its form, but is indestructible. More than that, a world is a living being, an entity with its own soul and intelligence. It must pass through a process of growth and development, analogous to the growth of a tree or of a human being. It is no mere form to say "The moving stars sang together and the Sons of God shouted for joy."

Translating the "evening and morning" of our English version to denote the geological period, you will find that the account given in Genesis does not differ in any essential form than that given by modern science. In the process of time, the human form was produced: all traditions agree that man was primarily androgynous. We may take it that the record so far brings us down to what is known as the Lemurian stage. The world was clothed and inhabited, but it was very much less solid than we know it. Then came the separation of the sexes and the subsequent awakening of desire with the resultant "Fall" and its accompaniment of physical conditions very much as they are today. Here we reach the Atlantean Epoch. Those who can read the Akashic Record* tell us that humanity reached a very high

***This is a record of all events of things that have happened and are about to happen. Some psychics refer to it as being like a library. The American psychic Edgar Cayce used to obtain many of his prophecies there. The Lemurian and Atlantean period are also discussed by Cayce in his tens of thousands of readings, at great depth.**

degree of civilisation. Now turn to the story of the Flood, and other lines of tradition speak of a great flood also. It is clear that at some time or another there existed a country that linked Africa and America, that some great cataclysm destroyed the country and drove the inhabitants to take refuge in the surrounding lands, forming colonies in Egypt, Mexico, Chaldea, India, and Mongolia.* All these colonies possessed certain traditions in common and recorded them with similar symbols. In all cases we find that beings of a Higher Race continued to appear occasionally and to impart instruction which was preserved more or less intact. The Hebrews claimed that their founder ABRAM came from Chaldea, his name AB-RAM, or Father of Ram, indicates that he was an Initiate of a High degree, for we find the title of 'father' associated with advanced grades of all schools. Moreover, he not only received direct teachings from the higher planes, but in obedience to it, he altered the whole mode of his life and set forth to found a new school, or Order as we say. Here we may pause for a moment to note a remarkable parallel in the story of all the great Initiates, Rama, Buddah, Moses, and our own Founder. At a certain stage in their own progress they were driven forth from their inherited surroundings to found a new Order, so was Mahomet, so today is Abdul Baha Abbas Effendi. It would seem that to preserve the life of the spirit it is essential from time to time to bring an upheaval, and transplantation must take place.

From the story of Abraham to the Apocalypse of St. John we have the history of Initiation. You may, as I have said, take it historically as containing the fragmentary record of a nation. You may find abundant evidence of cosmic myths and totemistic beginnings; it is *easy to see*, for instance, that the Ram was the totem of the ancient Hebrews and that it is therefore constantly referred to in these stories. Or you may say that the Sun passes

*See *Sacred Mysteries Among the Mayans and the Quiches* by Augustus le Plongeon, 1886; 1973 edition by Wizards Bookshelf. This book goes on to back up Mrs. Felkin's statements concerning common languages in America and Egypt.

into the Sign of Aries in the period of the substitution of the Ram for Isaac and the destruction of the Golden Calf of Moses. And again, you may quite accurately say that the story of Abraham represents the awakening of the human soul to the recognition which is inevitably followed by the sacrifice, the recognition of a Divine Presence and a sacrifice, actual or potential, of all to the Supreme Claim. It is the fashion now to speak of Jehovah as a Tribal Deity, to contrast his teaching and claims with those of CHRIST: yet if you look below the surface you will find that there is a fundamental identity. CHRIST also said "He that loveth father or mother, or wife or child, more than Me is not worthy": at some time or another in our progress we are confronted with that choice.

I do not propose to enter into any detailed analysis of the Bible: you can easily select points here and there which support the contention that to be understood it should be regarded from these varying standpoints. Take, for instance, the story of Joseph and his Brethren. On the face of it the number of actors immediately suggests a solar interpretation, the 12 brethren being the 12 Signs of the Zodiac. But again if you bear in mind a singular suggestiveness in this story, remember that in an Order the pupil is the Son, the teacher is also the Father. It is quite possible that in many cases this relationship was material as well as mental, but if we regard the Sons of Israel as being members of an Occult Order we will further recognise the fact that Joseph's coat of many colours was the robe of office with which Israel invested him as his chosen successor. It is natural then that the older members of the Order should resent having this youth appointed as their future Chief: their resentment was not lessened, but increased, when he showed, by his visions, that he was entitled to that office. Again we come to the necessary isolation and transplanting which the initiate must undergo. Jacob in his youth had been sent into exile that he might undergo his probation; Joseph must go through the same experience. I do not wish to lay down a hard and fast rule: I do not suppose that everyone who enters upon the Path must pass through this phase, but it has certainly been my experience.

There are two other characters whom I would like you to consider from the Order point of view, David and Solomon. David is pre-eminently the type of Seeker, eager, passionate, and impulsive. In modern language we would say that he had the artistic temperament, and since he never learned to control his passions and impulses, so he never attained to the higher grades, for it was not given to him to build the Temple. Solomon was exactly the reverse: in his youth he chose the mystic path: he asked for and received the high grades of Chokmah and Binah. In his arrogance he claimed that he need not undergo the probationary training: he need not lay the tiresome foundation in the etheric* nor gain the victory over the astral. And so GOD granted him the desire of his heart and sent leanness to his soul. Having been allowed to build the Temple he yet failed to dwell therein. To find the true Initiate of the Old Testament we must turn to Elijah or to Isaiah. Elijah, I think, stands for the ascetic: Isaiah for the mystic visionary, St. John the Baptist or St. John the Divine.

This brings us to the New Testament, and I want you for a moment to consider our everyday lives. I think that you will find, broadly speaking, that life falls into two great divisions. The small yet necessary incidents which occur but leave little or no trace. They belong entirely to the material plane and have no spiritual significance. But the other division belongs primarily to the spiritual plane and is indeed a reflection of that which exists externally. In reading the Gospels you will find that every incident recorded bears this interior cosmic significance. Commentators and critics may wrangle over the variations in the accounts given and over the probable dates of the writings, but those are details which concern us very little.

What does intimately concern us is that we have here the record from out of four widely differing standpoints of One Man's career. Try to realise that at the time when Jesus of Nazareth was born, there were numberless Orders in existence,

***The Etheric Body or plane is next to the world as we now perceive it. The Astral Plane is the next higher plane or level of existence.**

the Essenes, the Parsees, the Nazarenes, and the Gnostics. All these were the veils more or less to Hidden Orders of which there is no direct record but which can be traced indirectly. It was from these Orders that the Apostles and the Outer Circle of Disciples were drawn. The common attribution of the Kerubic emblems to the four Evangelists gives us a clue to their respective Orders:—

Matthew	Aquarius	Essene
Mark	Leo	Parsee
• Luke	Taurus	Thearapeut
John	Scorpio (Eagle)	Gnostics

Each of these was bound to have his outlook, memories and records, strongly coloured by his previous training, and yet how marvellously they agree in essentials.

I suppose most of you have wondered wherein Christianity differs from other great Wisdom religions. It is probably difficult for you to realise the attitude induced by the Calvinistic teachings which has made such a great profound influence on most Scotch and many English minds during the last three hundred years, though you partake of the subsequent rebound from that stern creed. The agnosticism of the 18th and 19th centuries was the inevitable revolt against the appalling doctrines of narrow minded ignorance which had striven to enslave men body and soul. Calvinism is in fact the counterpart of Islam, and in its logical position is that of a missionary with a Bible in one hand and a sword in the other. It was from this perversion of the teachings of Christ that the idea arose of GOD as an implacable Judge who could only be induced to pardon mankind from the everlasting punishment by the substituted punishment of a victim. This is not the teaching we find in the New Testament: what is?

You will remember in a previous lecture the diagram of the Principles on Man: I want you to observe that the attribution of Kether is Christos. Therein I think you will find the Key to the Inner Doctrines of Christianity, the doctrine which has been dis-

torted and misunderstood in the exoteric churches. When the Great White Christ incarnated in the chosen vehicle of Jesus, whose body was a product of 42 generations of selection (note that 42=Beth, the House of Sacrifice), a stupendous cosmic event was consummated. The Divine Christ Principle, which had hitherto existed only potentially, now became the integral part of humanity. This is why we are told that after the Crucifixion (which is the symbolic perfection of the Union between Human and the Divine) CHRIST descended into Hell, he preached unto spirits in prison. Thenceforth it became possible for each human being to become a Christos or Chrestos (anointed or perfected). "I am the way" CHRIST tells us, and again. "I , if I be lifted up, will draw all men unto Me."

The Calvinists evolved the extraordinary doctrine of "imputed righteousness," which has been well likened to clothing a dirty man in a clean garment. The Scriptures tell us that "He shall save His people from their sins": He is truly the Saviour, but He saves us from our sins, not from their logical results. The CHRIST shows us the way to rise above sin, He teaches us the perfect Law of Love: we are to love GOD with the whole being and our fellow beings as ourselves, as brothers.

He sanctifies every form of Love: marriage becomes a sacrament and children GOD's messengers. Friendship is holy because He had friends; service is dignified because He had served others; "Love fulfilleth the Law." And from out of Love springs the true doctrine of vicarious suffering; for the strong may suffer in order to help the weak: the Path of Initiation is in its very nature the willing acceptance of suffering. The Initiate endures hardships, not merely that he may become purified himself, but rather that by his suffering he may help others who are not yet initiated and thus draw to them nearer to Union with GOD. As our master is the Atonement for matter, uniting in the consummation of his earthly life, Humanity with Divinity, so each of us is permitted to become in one degree part of the Atonement until all is consumed and becomes infinite and holy.

So we find that the New Testament is the logical sequence to the old. In the Old Testament we have a record of partial Initia-

tion, the Way of the Glorified Adept, birth, suffering, endurance, vision, death, resurrection. And through all the consciousness of GOD in us, the Practice of the Presence of God.

Note: **Two small Fishes = Light and darkness, Positive and negative, Male and Female. Five Loaves= Pentagram, Spirit and Four Elements, undivided Man. 5000 = Human Race, traditional period from Adam to Christ. 12 baskets = Divisions of the race, 12 Tribes, 12 Apostles, 12 Signs.**

3

The Twelve Tribes and Astrology

by MacGregor Mathers

The Twelve Tribes* are thus attributed to the Twelve Zodiacal Signs and permutations of the Great and Holy Name of Tetragrammaton and the Angelic counterparts:

Sign	Letters of the Name	Tribe	Angel
Aries	Yod Heh Vau Heh	Gad	Melchidael
Taurus	Yod Heh Heh Vau	Ephraim	Asmodel
Gemini	Yod Vau Heh Heh	Manasseh	Ambriel
Cancer	Heh Vau Heh Yod	Issachar	Muriel
Leo	Heh Vau Yod Heh	Judah	Verchiel
Virgo	Heh Heh Vau Yod	Naphthali	Hamaliel

*This lecture by Mathers has two versions. The only difference between them is that the Enochian names are placed in front of each tribe in one version. The Golden Dawn gave this lecture out at the 4=7 Grade. At Whare Ra Temple, it was given out first at 4=7 for a very brief time, then later at 1=10. It was incorporated into the " papers, though no indication is given in the Whare Ra papers as to who wrote it.

Libra	Vau Heh Yod Heh	Asshur	Zuriel
Scorpio	Vau Heh Yod Heh	Dan	Barchiel
Sagittarius	Vau Yod Heh Heh	Benjamin	Advachiel
Capricorn	Heh Yod Heh Vau	Zebulun	Hanael
Aquarius	Heh Yod Vau Heh	Reuben	Cambriel
Pisces	Heh Heh Yod Vau	Simeon	Amnitzel

Of these, especially the Bull, the Lion, the Scorpion (but in good symbolism the Eagle) and the Man are to be noted as forming the Kerubic figures of Ezekiel and John. To these signs are allotted the tribes of Ephraim, Judah, Dan and Reuben, who, as we shall presently see, encamped towards the Cardinal Points around the Tabernacle of the Congregation, and *as* the leaders of the others. The signs of the Twins, the Fishes, and in a certain sense as a compounded figure,* the Centaur armed with a bow, are also called bi-corporate, or double-bodied Signs. 'Ib these refer Manasseh, Simeon and Benjamin. Manasseh was divided into two half tribes with separate possessions (being the only tribe thus divided), and thus answers to the equal division of the Sign of the Twins, Castor and Pollux, the Great Twin Brethren. Simeon and Levi are classed together, like the two Fishes in the Sign, but Levi is withdrawn later, to form as it were the binding and connecting link of the Tribes, as the priestly caste. Benjamin is the younger brother of Joseph, for Rachael had only these *two* sons, and is the only one of the sons of Jacob who at his birth was called by two names, for Rachel called him "Ben oni," but his father Benjamin, and in the sign of the two natures of Man and Horse are bound together in one symbol.

We shall find much light upon the connection between the Signs and the Tribes shown by the blessing of Jacob, and of Moses, from the former of which the Armorial bearings of the Twelve Tribes are derived.

Let us note that as in the Tribes Levi was withdrawn, and the

*For an in-depth study of these tribes, see "The Testament of the Twelve Patriarchs" in *Lost Books of the Bible & the Forgotten Books of Eden*. Also see Ethelbert Bullinger's *Witness to the Stars*.

two Tribes of Ephraim and Manasseh substituted for the simple one of Joseph, so in the New Testament, Judas is withdrawn from the number of the twelve Apostles and his place filled by another, Matthias, who was chosen by lot to fill his place.

The following is the order by birth, of the children of Jacob: Leah bore Reuben \approx , Simeon \times , Levi, afterwards withdrawn, and Judah. Bilhah (Rachel's maid) bore Dan \mathcal{M} and Naphthali \mathcal{N} . Zilpah (Leah's maid) bore Gad Υ and Ashur Leah again bore Issachar σ , Zebulun \mathcal{V} and Dinah (a daughter). Rachel bore Joseph, whose sons were Manasseh Π and Ephraim \mathcal{O} , but died at the birth of Benjamin \nearrow , whom she wished to call Ben-oni.

In the Wilderness the Tabernacle was pitched in the midst, and immediately surrounding it were the tents of Levi. At a distance towards the four cardinal points were the standards of the Twelve Tribes erected thus:—

East	Judah, Kerubic Sign of \mathcal{O} with Issachar σ and Zebulun \mathcal{V}
South	Reuben, Kerubic Sign of \approx with Simeon \times and Gad Υ
West	Ephraim, Kerubic Sign of \mathcal{O} with Manasseh Π and Benjamin \nearrow
North	Dan, Kerubic Sign of \mathcal{M} (Eagle) with Asher \simeq and Naphtali \mathcal{N}

[See also the diagram on the following page.]

Save for the Kerubic emblems, the arrangement seems at first very confused; but when we notice the Maternal Ancestors of the Tribes, this confusion disperses, and we notice that at the East are three tribes descended from Leah, viz. Judah, Issachar and Zebulun. Opposite to them, towards the West, three tribes descended from Rachel, viz. Ephraim, Manasseh and Benjamin. At the South are two descended from Leah and one descended from Zilpah, viz. Reuben, Simeon and Gad, and at the North, two descended from Bilhah and one descended from Zilpah, viz. Dan, Naphthali and Asher. Here two tribes descended from Zil-

pah, Gad and Asher, are the only ones separated, and placed in opposition to each other, for these are two signs of the Equinoxes.

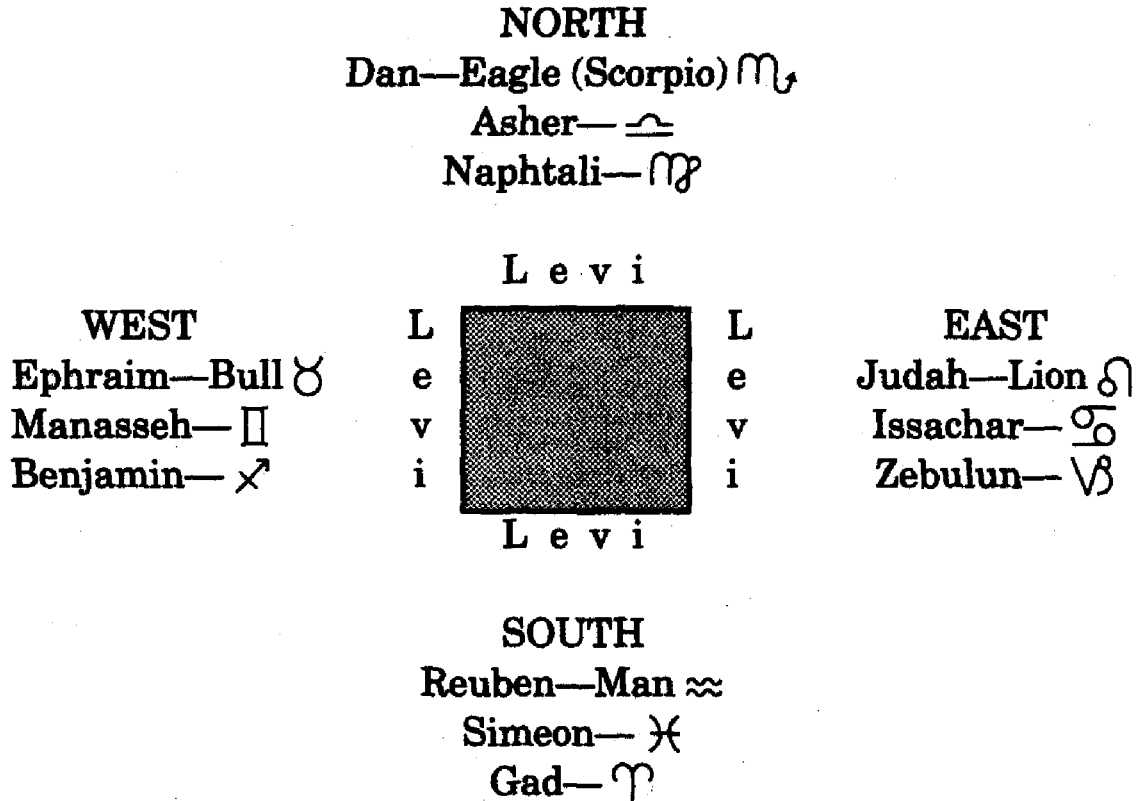

The substitution of the two tribes of Ephraim and Manasseh for the single one of Joseph is given in Genesis 48, where Jacob blessed them prior to the general blessing of the Tribes, stating at the same time that Ephraim, though the younger, should take precedence over Manasseh: "And Jacob said unto Joseph . . . And now thy two sons, Ephraim and Manasseh, which were born unto thee in the land of Egypt before I came unto thee in Egypt, are mine; as Reuben and Simeon they shall be mine. And thy issue which thou begettest after them shall be thine and shall be called after the name of their brethren in their inheritance . . . Moreover I have given unto thee one portion above of thy brethren."*

Let us now notice the blessings of Jacob and Moses, and corn-

*This is the Assyrian fish-god Vannes, who was half man and half fish.

pare them with the Signs of the Zodiac attributed to each Tribe. We shall take them in the Zodiacal order.

Of Gad (Aries), Jacob says, "Gad, a troop shall overcome him, but he shall overcome at the last." Moses says, "Blessed be he that enlargeth Gad: he dwelleth as a lioness, and teareth the arm with the crown of the head, and he provideth the first part for himself because there, in a portion of the law-giver, was he sealed; and he came with the heads of the people, he executed the justice of the Lord, and his judgements with Israel." The armorial bearings of Gad are, white, a troop of cavalry. All this coincides well with the martial and dominant nature of Aries, the only one of the twelve signs in which the superior planets alone bear sway, for it is the House of Mars, exaltation of the Sun and triplicity of Sun and Jupiter. The symbolism of the Lion is also proper to Aries on account of its solar, fiery and martial nature.

Of Ephraim and Manasseh (Taurus and Gemini), classed together under their father's name, Jacob says, "Joseph is a fruitful bough, even a fruitful bough by a well, whose branches run over the wall; the archers have surely grieved him and shot at him, and hated him: but his bow abode in strength, and the arms of his hands were made strong by the hands of the mighty God of Jacob; (from thence is the shepherd, the stone of Israel:) Even by the God of thy father, who shall help thee, and by the Almighty who shall bless thee with the blessings of Heaven above, blessings of the deep that Beth under, blessings of the breasts and of the womb: the blessings of thy father have prevailed above the blessings of my progenitors unto the utmost bound of the everlasting hills: they shall be on the head of Joseph, and on the crown of the head of him who was separate from his brethren." Moses says, "Blessed of the Lord be his land, for the precious things of heaven, for the dew, and for the deep that coucheth beneath, and for the precious fruits brought forth by the Sun, and for the precious things put forth by the moon, and for the chief things of the lasting hills. And for the precious things of the earth, and the fullness thereof, and for the good will of him that dwells in the bush: let the blessing come upon

the head of Joseph, and upon the top of the head of him that was separate from his brethren. His glory is like the firstling of a bullock, and his horns are like the horns of unicorns: with them he shall push the people together to the ends of the earth, and they are the ten thousands of Manasseh.'

The Armorial Bearings of Ephraim are: Green, an Ox. Those of Manasseh are flesh-colour, a Vine by a Wall. All this refers to the natures of Taurus and Gemini, the firstling of the bullock and the earthy nature of the sign, shown by the hills, to Taurus while the archers over Manasseh, as Sagittarius, the sign of the Archer, is in opposition to Gemini.

Of Issachar, Cancer, Jacob says: "Issachar is a strong ass couching down between two burdens: and he saw the rest was good, and the land that it was pleasant, and he bowed his shoulder to bear, and became a servant under tribute." Moses says: "Rejoice Issachar, in thy tents . . . and they shall suck of the abundance of the seas." The armorial bearings of Issachar are Blue, and an ass crouching beneath its burden. This coincides with the peaceful nature of the quiet and watery sign of Cancer.

Of Judah, Leo, Jacob says: "Judah, thou art he whom thy brethren shall praise: thy hand shall be in the neck of thine enemies; thy father's children shall bow down before thee. Judah is a lion's whelp: from the prey, my son, thou art gone up; he stooped down, he crouched as a lion, and as an old lion; who shall rouse him up? The sceptre shall not depart from Judah, nor a lawgiver from between his feet, until Shiloh come; and unto him shall the gathering of the people be. Binding his foal unto the vine, and his ass's colt unto the choice vine; he washed his garments in wine, and his clothes in the blood of grapes: his eyes shall be red with wine, and his teeth white with milk." ' Moses says, "This is the blessing of Judah, and he said, Hear, Lord, the voice of Judah, and bring him unto his people, let his hands be sufficient for him and be thou an help to him from his enemies." The armorial bearings of Judah are Scarlet, a lion rampant. All this well agrees with the regal and leonine nature of the Sign. "Binding the ass's colt unto the choice vine" may allude to the ass of Issachar, Cancer, lying between Judah, Leo,

and the vine of Manasseh, Gemini.

Of Naphthali, Virgo, Jacob says, "Naphthali is a hind let loose, he giveth goodly words." Moses *says*, "O Naphtali satisfied with favour, and full with the blessings of the Lord, possess thou the West and the South." The armorial bearings of Naphthali *are* Blue, a hind.

Of Asher, Libra, Jacob *says*, "Out of Asher his bread shall be fat, and he shall yield royal dainties." Moses *says*, "Let Asher be blessed with children, let him be acceptable to his brethren, and let him dip his foot in oil. Thy shoes shall be iron and brass, and as thy days, so shall thy strength be." The armorial bearings of Asher are Purple, a Cup. All this coincides with the nature of Venus and Libra, while the feet refer to the sign of Pisces, which rules the feet, and in which Venus is exalted. Iron and Brass are the metals of the friendly planets of Mars and Venus.

Of Dan, Scorpio, Jacob says: "Dan shall judge his people as one of the tribes of Israel. Dan shall be a serpent by the way, and adder in the path, that biteth the horse's heels, so that his rider shall fall backward. I have waited for thy salvation, O Lord." Moses says. "Dan is a lion's whelp, he shall leap from Bashan." The armorial bearings of Dan are Green, an Eagle. These things fit with the martial and fierce nature of this sign in which Mars principally bears sway. To the sign of Scorpio, the Egyptians attributed the Serpent, and also Typhon, the Slayer of Osiris, and on this account they call it the "Accursed Sign." In good symbolism it is generally represented by the Eagle. The horse's heels which the Serpent sometimes bites are found in the Centaur figure of Sagittarius which follows Scorpio in the Zodiac.

Of Benjamin, Sagittarius, Jacob says, "Benjamin shall ravin as a wolf: in the morning he shall devour the prey, and at night he shall divide the spoil." Moses says: "The beloved of the Lord shall dwell in safety by him; and the Lord shall cover him all the day long, and he shall dwell between his shoulders." The armorial bearings of Benjamin are Green, a Wolf. These suit the character of Sagittarius, partly keen, partly of the nature of Jupiter, and partly brutal.

Of Zebulon, Capricorn, Jacob says: "Zebulon shall dwell at the

haven of the sea, and he shall be for a haven of ships, and his border shall be unto Sidon." Moses says: "Rejoice Zebulon in thy going out, and Issachar in thy tents, they shall call the people unto the mountain, there they shall offer sacrifices of righteousness, for they shall suck of the abundance of the sea, of the treasures hid in the sands." This suits well the tropical, earthy and water signs of Capricorn and Cancer, The armorial bearings of Zebulon are Purple, a Ship.

Of Reuben, Aquarius, Jacob says: "Reuben, thou art my first-born, my might, and the beginning of my strength, the excellency of dignity and the excellency of power. Unstable as water, thou shalt not excel, because thou wentest up to thy fathers bed, then defiledist thou it; he went up to my couch." Moses says: "Let Reuben live and not die, and let not his men be few." The armorial bearings of Reuben are Red, a Man. "Unstable as water" is still shown in the undulating hieroglyphic which marks this aerial and brilliant, but often superficial sign of the Water-Bearer.

Of Simeon and Levi, Pisces, Jacob says: "Simeon and Levi are brethren; instruments of cruelty are in their habitations. O my soul, come not thou into their secret, unto their assembly, mine honour, be not thou united: for in their anger they slew a man, and in their selfwill they digged down a wall. Cursed be their anger, for it was fierce; and their wrath, for it was cruel: I will divide them in Jacob, and scatter them in Israel." This alludes to their smiting Shalem, the city of Hamor and Shechem, and slaying the latter because they had carried off Dinah, the daughter of Leah. Moses says of them: "Let thy Thummim and thy Urim be with the Holy One, whom thou didst prove at Masah, and with whom thou didst strive at the water of Meribah; who said unto his father and mother, I have not seen him; neither did he acknowledge his brethren, nor knew his children; for they have observed thy word, and kept thy covenant. They shall teach Jacob thy judgements and Israel thy law: they shall put incense before thee, and whole burnt sacrifice upon thine altar. Bless, Lord, his substance, and accept the works of his hands; smite through the loins of them that rise against him,

and of them that hate him, that they rise not again." The armorial bearings of Simeon are Yellow, a Sword.

These are the blessings of the twelve tribes of Israel, whose names were engraven upon the twelve stones of the High Priest's breastplate, upon which, according to some traditions, certain flashes of light appeared playing over certain of the letters, and thus returning the answer of the Deity to the consulter of the Oracle of the Urim.

By comparing these blessings with the nature of the Signs attributed to the particular tribes, we have thus been enabled to trace more or less clearly the connection between them, and also the derivation of the armorial bearings ascribed to them in Royal Arch Freemasonry

Daily Rhythm for the 1=10*

On Rising: 1=10 Sign and say

"May the Fire of the Sun fill me with Life."

Bath: "May the purity of this water be mine."

Dressing: "Except Adonai build the house their labour is but lost who build it, Except Adonai keep the city, the watchmen waked' but in vain."

I am unable to trace whether this was an original Golden Dawn document or something used only by the Stella Matutina or Wham Ra in particular. Person, I find this "Rhythm" just a bit too Christianized for my taste, but for those who wish to use their own phrasing, it is an ideal way to become more aware of what grade you are working from. At Thoth Hermes, all those who go through this grade do the invoking pentagram of Earth in each quarter and then recite the prayer of the Gnomes from the ritual itself instead of using the "Daily Rhythm? The effect is quite stimulating when done every morning and evening, and it is every bit as effective as the 'Daily Rhythm,' if not more so. The same procedure is then carried out with each of the elemental grades.

Noon.: "Let the earth Adore Adonai."

**Evening: "Let the Earth Adore the Lord and King of the earth,
Adonai, Adonai Ha-Aretz, Adonai Malekh. Blessed be Thy
Name to the countless ages—Amen."**

**Night: "O Stability in Motion,
O Darkness veiled in Brilliance,
O day clothed in night,
O master who never doth withhold the wages of Thy workmen, O
silver whiteness,
O Golden Splendour,
O Crown of living and harmonious diamond,
May the blessing of Adonai be upon you all."**

**Affirmations: An easy way to gain strength during the day is
by use of Affirmations. Such as:**

**"Praise the Lord O my Soul and all that is within me praise
His Holy Name"**

"All things are possible etc."

**"He will give strength and power unto His people,
Let those who seek Thee be glad and joyful."**

The Elementals of the Earth Grade: The Gnome?

We are all so accustomed to the presence around us of plants, trees, insects, reptiles, animals and birds that we take them for granted and do not realize how entirely alien their lives are from our own. They belong, in fact, to a different world from ours and their outlook must be from a different angle.

But when we are told there are other living creatures not normally perceptible to our senses, we are apt to reject the idea as the survival of old fables and fairy tales. Nevertheless, such beings not only exist, but are of vital importance both to us personally and to the conduct of the world at large. Without their presence and unceasing activities the processes of life as we know it would cease to function. Let us examine this statement in some detail.

Where does life begin and how does it manifest itself?

*This is not a bad little paper, though unfortunately it does not go far enough. I do suggest the reader obtain a copy of the book *Devas and Men*, a compilation of work put out by the Theosophical Society, which goes into great detail on both elementals and devas. The structure of the elementals is an area that the Golden Dawn did not go into far enough.

Not so many decades ago we should have said that life begins with plants and manifests in movement. Now we have to realize that movement is to be found everywhere, in minerals, in metals, in earth, air, water and fire. So it seems profitable to think that there must be some form of life present in all the kingdoms of the world. Consider the Element of Earth for instance. Here we find the foundation of all the forms of life with which we are familiar. But if life springs from the earth then life must be inherent therein. Even in the great deserts of the world there is some form of life to be found, it may be in those curious plants which we class as cacti; it may be in the multifarious forms of insects and beetles. At the opposite extremes from these we have the teeming forests and swamps.

Both these extremes have one common requirement—that of movement—if the earth is to support life then it must be kept in constant movement; rocks must be broken up, soil must be crumbled and the various constituents of earth must be mingled in order to supply the necessary combination of the appropriate forms derived from it.

Now the expansion of these various movements rests in the hands of the gnomes. They are actually the living essences of the Earth and by their constant activity and unremitting attention they enable the Earth to nourish all other forms of life, directly or indirectly. In the old legends the Gnomes, Goblins, Pixies and Brownies are represented as guardians of treasure—as indeed they are. They guard the secret treasure house of life's origin and their unending task is to shift and blend in perpetual permutations. To form the veins of metal, the matrix of gems, they must call in the aid of the Fire Spirits, the Salamanders, so that together they may exert an inconceivable amount of pressure; for metals and gems are the product of the compression of certain ingredients. For the support of any form of plant life they must have the assistance of the Gnomes and Sylphs since a plant demands moisture and air to stimulate its growth. The Gnomes guard the activity of earth and roots, but the Sylphs must reserve and supervise the stems and leaves as soon as they appear above the ground.

Another thing that we find very hard to realize is that just as our

eyes and ears can only discern a very small section of the immense scale of vibrations which build up the Universe, so also, our perceptions are usually aware of only those forms which approximate our own in vicinity. This applies to both ends of the spectrum. Our eyes cannot perceive the colors below dark crimson or above the delicate pinky-lilac which marks our boundaries, neither can our ears distinguish sounds below or above a certain range. In the same way we are normally unaware of forms which are either extremely dense or extremely tenuous, although such forms do exist and may, under given' conditions, impinge upon our consciousness. We know from observation and experience that living creatures can move through those elements which are somewhat less dense than themselves, and that they must be formed to resist the external pressure of their own element. A fish moves with ease through the water, a bird through the air. Animals and man being denser than either of these require the support of earth to enable them to move easily in either water or air. But being more adaptable than fish or bird, man (and a few animals) can free himself to discard earth for a long period. Man can learn to swim, but if he is to fly he must have some support.

The Gnomes, and certain other entities with which we are not now concerned, live and move with ease through the earth. They are so dense that earth is to them as air is to us, and they move through it without consciously seeing it although they are aware of its varying degrees of density and the pressure exerted, just as we are aware of wind.

The human senses are not unlike stringed instruments which can be tuned in to a lower or a higher pitch. Therefore, it is possible so to tune in our perceptions that we become more or less clearly aware of these extra-normal living creatures. We know that the more any sense is trained, the more sensitive it becomes. A musician can distinguish notes to which an unmusical person is deaf; an artist perceives colors to which most of us are blind. And in the same way a trained occultist becomes aware of the infinite range of life which is in active existence all about us.

Part 4

*The Ritual According to
A. E. Waite*

The Ceremony of Advancement in the 1=10 Grade of Zelator

*Newly Constructed from the Cipher Manuscripts,
and Issued by the Authority of the Concealed Superiors
of the Second Order, to Members of Recognised Temples*

*A. E. Waite's Version of the Zelator Ritual
Privately Printed 1910*

The Solemn Ceremony of Opening the Temple in the Grade of Zelator

The arrangement of the Temple is shown in the Official Diagram of the First Point.

If the Temple should not have been opened previously in the Grade of Neophyte, the ceremonial robing of Members and Officers, the clearing of the Temple and the Invocation at the Throne of the East are performed as exhibited therein. The Hierophant takes his place and assumes the Sceptre of his Office. The Members and Officers are seated, the position of the Zelatores being in the North-East of the Temple. The titles and duties of Officers are identical with those of the Neophyte Grade.

Hierophant: —1—

All rise. The Sentinel leaves the Temple.

Hierophant: Fratres et Sorores *of the Holy and Glorious Order of the assist me to open the Temple with recollection and great reverence in the Grade of Zelator. Frater Kerux, I direct you to see that the Temple is guarded on the hither and further sides, remembering the Treasure that is within.*

The Kerux raises his Lamp and Wand in obeisance to the Hierophant, and passing to the door of the Temple knocks once on the hither side--1--. The Sentinel responds on the outer side, using the hilt of his Sword-1--. The Kerux turns to the East with uplifted Wand.

Kerux: *Truly Honoured Hierophant, I testify by the Pearl of Great Price that the Portal is watched and guarded.*

Hierophant: Fratres et Sorores, *let us see to the guarding of the sacred and beautiful Light which has come in the Morning Redness to hearts that are prepared within.*

This is said with raised eyes and uplifted Sceptre, and there follows a moment's pause.

Hierophant: Honourable Frater Hiereus, *I command you to prove the Brethren; assure yourself that all present have been advanced to the Grade of **Zelator** and are zealous students, seeking the Holy Ends.*

The Hiereus leaves his Throne, passes to the door of the Thmple, where he draws his Sword and uplifts it.

Hiereus: Fratres et Sorores, *in the name of the Holy Watchers, and by the ordinance of the Truly Honoured Hierophant, I demand the Sign of the Grade.*

This being duly given, the Hiereus sheathes his Sword.

Hiereus: *Truly Honoured Hierophant, in obedience to your commands, I have received from the **Fratres et Sorores** the Sign of intervention and mediation, which is that of the Grade of Zelator.*

He communicates the Sign to the Hierophant, by whom it is

repeated in turn.

Hierophant: *I testify on my own part, and on behalf of the whole Order, that we who are present have been dedicated by our own free will, and have pledged and set apart ourselves, seeking the high things belonging to this Grade of Zeal. Interpose, O Lord, in Thy mercy, and so sustain those who have entered within the Gate that they may come at last to Thy Presence.*

This is said with raised eyes and uplifted Sceptre, and there follows a moment's pause.

Hierophant: *Let the Temple be hallowed with sacred fire, to symbolise that consecration of the earthly part of our nature which God fulfills within us.*

If the temple has not been consecrated previously in the Neophyte Grade, the Dadouchos comes round with the sun to the Throne of the Hierophant, the blessing of the Vessel of Incense takes place in the prescribed form and the Dadouchos returns with the sun to his proper place. Then—and in either case—he advances to the Pillars and, standing between them, makes a Cross in the air with his Thurible and offers incense three times. He makes obeisance to the Hierophant between the Pillars and uplifts his Vessel.

Dadouches: *It is written that God shall save both man and beast. I have consecrated the Ample with Fire.*

He returns to his place.

Hierophant: *Let the Temple be cleansed with water, to symbolise the greater purification, by which we are purified from stain in our earthly part.*

The same form of procedure is followed by the Stolistes, and when he passes between the Pillars he makes a Cross with his Aspergillus and sprinkles thrice. Thereafter he makes obeisance to the Hierophant and raises the Cup of Water.

Stolistes: *He that is washed, needeth not save to wash his feet, but is clean every whit. I have purified the Temple with water.*

He retires to his place. The Kerux comes forward and, standing between the Pillars, lifts up his Lamp and Wand, saying:

Kerux: *The body of the Temple is cleansed.*

Hierophant: *But I testify that there is another Temple, which is the body of man and his actions. Do Thou cleanse, O Lord, our earthly part, and bring us to see Thy face.*

This is said with raised eyes and uplifted Sceptre, and there is a moment's pause.

Hierophant: *Let us name the Element to which this Grade is attributed, that the sense of its dedication may be awakened, O Honourable **Hegemon**, in the hearts of those who are here and now present and in the uplifted heart of the Order.*

Hegemon: *It is the Grade of the Element of Earth and the material of the work of the wise. The earth is the Lord's and His is the fullness thereof.*

Hierophant-1—: *Now, therefore, **Fratres et Sorores**, let us offer up our souls in adoration, giving glory and thanks and honour to the Lord and King of Earth.*

The Hierophant descends from his Throne and faces the East front of it.

Hierophant (with upraised Sceptre in the sign of the 1=101 Grade): *Adonai Ha Aretz, Adonai Malkah (he makes the Kabalistic sign of the), unto Thee be the Kingdom, the Power and the Glory, **Malkuth, Geburah and Gedulah**, the Valley of Vision, the Seat of Judgment and the Place of Magnificence: unto Thee be the Rose of Sharon, the Lily of the Valley, the indwelling glory and fountain of all influx, wherewith the Garden is watered for ever and ever.*

This Sign of the Grade is given by all present. The Kerux proceeds to the North and sprinkles Salt before the Tablet of the North, saying:

Kerux: *Amen. Let the earth adore Adonai.*

He returns to his place. The Hierophant faces West, standing in front of his Throne, and says with raised eyes and uplifted Sceptre:

Hierophant: *And purified, consecrated, dedicated, let the part of earth of his servants, the holy body of man, adore Adonai.*

He proceeds by South around the Altar to the Northern part of the Temple and there as he pauses:

Hierophant: *For the body is a holy sanctuary and the Lord is the light therein. Wherefore we look for its adoption, to wit, the redemption of the body, that it may be the body of heaven in its clearness.*

The Hierophant stands facing the Tablet of the North, at a convenient distance, say, six feet therefrom. The thereus, coming up by the North, takes his place at the right of the Hierophant, and the Hegemon is on his left side. The Stolistes stands behind the Hiererus and the Dadouchos behind the Hegemon. All Officers and Members face North.

Hierophant: *From the Palace at the Centre, the Sublime Palace, wherein is the King in His Beauty, to the Palace of Material Things, wherein reigns the Lord of the visible world in the likeness of the Lord of Glory, the order and sequence, of high and holy mysteries proceeds without break or interruption, and man aspires to the Eternal in the height and depths of his nature. In the mystic name **Adam**, the letter **Aleph** looketh towards the Supreme Crown; the letter **Mem** looketh towards the Great Mother in **Binah**, who is the Divine Mother of souls; but the letter **Daleth** looketh towards the **Sephira Malkuth** and the mother in manifestation. May the grace of the Lord descend upon me and the brightness of the*

Lord encompass me, while I recite the Sacred Invocations.

The Hierophant lifts up his Sceptre.

Hierophant: *It was said of old by the Elohim: Let us make Adam in our image, after our likeness—the things which are manifest after the mode of things that are unmanifest and the will below in correspondence with the will which is above. It was said also: Let them have dominion over the fish of the sea and the lower emotions which they symbolise; over the fowl of the air, which are the wandering thoughts of the mind; and over the cattle and over all the earth—over every material part—and over every creeping thing that creepeth upon the face of the earth. And the Elohim created Eth-HaAdam, which is the Archetypal Man, as the pattern of the natural man; in the image of the Elohim created they him, male and female created they them.*

The Hierophant makes a great circle in the air concentric with the Tablet of the North. Therein he makes the Invoking Pentagram of Earth, saying:—

Hierophant: *Sanctify our congregation, O Lord; clothe us with the garment of salvation; cover us with the robe of righteousness, as a bridegroom is adorned with jewels. In the name of Adonai Malkah, the Bride and Queen of the King. dom, looking towards the Gates of Light, Spirits of Earth, adore Adonai.*

He hands his Sceptre to the Hiererus, takes the Sword of the Hiererus, and makes the Sign of the Ox therewith in the centre of the Pentagram, saying:—

Hierophant: *In the Name of Auriel, the Great Angel of Earth, Leader of Heavenly Hosts, in memory of the manifested Law, and by the sign of the Head of the Ox, Spirits of Earth, adore Adonai.*

Returning the Sword to the Hiererus, he takes the mitre-headed Sceptre of the Hegemon and makes a Cross in the

air, saying:—

Hierophant *By the sacred Names and Letters which are inscribed on the Tablet of Earth, and by the inward mystery which they communicate, Spirits of Earth, adore Adonai.*

Returning the Sceptre to the Hegemon, he takes the Cup of the Stolistes and, making a ffl, sprinkles thrice in the North, say-

Hierophant: *By Emor Dial Hectega, the Divine Names which are written about the Northern Quarter of the Universe, by the protection from the enemy therein, and by their grace operating in man, Spirits of Earth, adore Adonai.*

Returning the Cup to the Stolistes, he takes. the Thurible from the Dadouchos and, making a ffl, offers incense, swing:-

Hierophant: *By Ic-Zod-He-Chal, the Sacred Name attributed to the Symbolic King of the North, Spirits of Earth, adore Adonai.*

Returning the Censer to the Dadouchos, he receives his Sceptre from the Hiereus, and goes back to his Throne in the East. The other Officers also return to their places. All members face as usual.

Hierophant (with raised face and uplifted Sceptre): *Seal us, O Lord, for ever with Thy Holy Names; may they be written about the hearts of Thy servants. Fratres et Sorores, the Spirit and the Bride say, Come; and come therefore, my Brethren: bring offerings of aspiration and come into the House of the Lord. In the Name of Adonai Malkah, the House is swept and garnished; the Temple is duly opened in the Holy Grade of Zelator.---1 11 All 1 11*

The Battery is repeated by the Hiereus and Hegemon. The Sentinel re-enters the Thmple. Officers and Members are seated. Here ends the Solemn Ceremony of Opening the Temple in the Grade of Zelator.

The Ceremonial Advancement of a Neophyte to the 1=10 Grade of Zelator

The First Point

The Hegemon is seated at the eastern side of the Altar, facing West. The Throne of the Hierophant has been placed on the southern and that of the Hieres on the northern side of the Altar, both facing West. The Kerux, Stolistes and Dadouchos occupy a parallel line behind the Pillars and looking towards the East.

Hierophant: *Fratres et Sorores, the dispensation of the High Light has been committed to our charge, working towards the will in its conversion under the mystery of the Divine Will; and seeing that from the Unknown Superiors, who communicate the gifts of compassion behind the order of the .• .• I have received a warrant for its exercise in the person of our beloved Frater, **Adveniat Regnum (vel alius), a Neophyte of this Holy Order, and am empowered duly to promote him from the Portal of the .• .• I beseech you to unite with me spiritually in the consecration of his natural body for the better manifestation, the greater preparation and liberation of the man within. Do you therefore, Honourable Frater Hegemon, our Mediator and Reconciler, Prince of Purity and Lord of Peace, go forth and prepare the Candidate, in the grace and the light, the benediction and mystic beauty, of your all-saving office.***

The Hegemon rises, makes obeisance with the Sign of the grade and leaves the Temple by South and West.

Hierophant: *Fratres et Sorores, the Neophyte is prepared in the body because already he is prepared in the mind; he holds the outward warrants of advancement, being warranted from within the Order, seeing that we are acquainted with his zeal. The light is not hidden which he received in the Portal of the ... pray you to prepare for him a place in your own hearts, that the love of brotherhood may encompass him who*

is on the Quest of Divine Love. Concur with me also in his advancement, that with recollection and reverence we may lead him beyond the gate and place him at the entrance of that symbolic path which leads to the Hidden Wisdom.

The Hegemon has in the meantime prepared the Neophyte, who wears the Ribbon of his Grade, is hoodwinked and carries the Fylfot Cross in his right hand. The Hegemon instructs him in the battery proper to the Grade. When it has been given by the Neophyte, the Kerux turns down the lights and opens the door, so that it is just ajar.

Hegemon (speaking for Candidate): *Let me enter the Gate of Wisdom, for without are darkness and sorrow, and the eye opens in vein.*

The Kerux throws back the door and admits them. It is closed by the Sentinel.

Kerux: *May that which has opened at your knocking be even as the House of God and to you as the Gate of Heaven.*

Hegemon (for Candidate): *Open to me the gates of righteousness; I will go into them; I will praise the Lord.*

Kerux: *Come in peace. The Lord loveth the Gates of Zion more than all the dwellings of Jacob.*

The Hegemon advances slowly with the Candidate, and pauses at the speech of the Hierophant.

Hierophant: *The beginning of wisdom is the most true desire of discipline, and the care of discipline is love, and love is the keeping of her laws; and the keeping of her laws is the firm foundation of incorruption; and incorruption bringeth near to God. Therefore the desire of wisdom bringeth to the everlasting kingdom.*

Hegemon: *I have passed through the gates of understanding; I have come to the gate of wisdom; I have passed the threshold thereof: O give unto me the path of peace, the path*

which leads to the Temple and the place where wisdom dwells. I will build my tabernacle thereby and abide in the light of her presence.

Hierophant: *Except the Lord build the House, they labour in vain that build it; except the Lord keep the city, the watchman waketh but in vain. May He keep your city for ever, O Neophyte of the .• .• .. May He build your house in beauty. By what aid have you come to our Portal? Who has brought you across the threshold? Who leads you on this holy ground?*

Hegemon: *The call has come to the Wardens, and by a gracious act of intervention they have decreed the advancement of this our beloved **Frater**. The call is dual and the call is also one; it is from the depths of the heart of the aspirant and from that which is withdrawn in the Order—a sacred motive working in goodwill towards man. The Neophyte therefore enters by an act of permission and an act on his own part. The aids to entrance are in the sense of this dual motive. It is written that the earth is the Lord's and the fullness thereof; the Neophyte is guided by Adonai, the Lord of the earth. He is qualified by the knowledge that there is a secret path of wisdom; he is recognised by the dispensation, which you hold; the secrets of the 0=0 Grade are treasured in his heart; and he carries the Hermetic Cross.*

The Hegemon takes the Symbol, exalts it in the sight of the Hierophant, and it is then given to the Kerux.

Hierophant: ***Frater Kerux**, I direct you to receive from the Neophyte the Step, Sign, Token, Grand-Word and temporal Pass-Word communicated at the last Equinox.*

This is done accordingly, the Candidate being prompted when necessary and assisted throughout by the Honourable Frater Hegemon, with fraternal and loving care. Having received the Pass-Word, the Kerux faces the Hierophant, giving the salute of the Grade, and says:—

Kerux: *Truly Honoured Hierophant, I have received the secrets of the Neophyte Grade.*

Hierophant: ***They are the outward forms of our mysteries; let us remember that the body of our sacred Ritual is not not without its spirit. . . . Frater Hegemon, you will lead the Neophyte to the due West of the Temple, and place him between the Pillars, with his face toward the East.***

This is done is due form, the Hegemon leading the Candidate.

Hierophant: *Frater Adveniat Regnum (vel alius), he who certifies that God is his aid, when he enters our Holy Temple, will ever command our own. Stand therefore, Frater, and, erect between the mystic Pillars, bear witness to your high intention. Do you covenant to maintain the same honourable and perfect silence regarding the Mysteries of this Grade which you have already been pledged to preserve respecting those belonging to the Portal of the .• .• .? Will you never reveal them to the world? Will you never confer them on a Neophyte, except by dispensation from the Second Order? And do you testify with true lips, in the presence of the brethren who are here and now assembled, that the dispositions that brought you to the Portal have passed into a sense of dedication, and that you will continue to the best of your ability to be worthy of your high calling?*

The Neophyte (being prompted by the Hegemon and repeating the words after him): *I pledge my soul to silence; I will communicate only as I have received in the ceremonies of the Temple, and the sense of my dedication burns like a holy fire in my heart.*

Hierophant: *I now bid you kneel down, place your right hand upon the earth, and as one who calls upon his proper body in testimony, say in a clear voice: I give my body to the gods; I will go where the great gods are: I swear by the earth whereon I kneel and by the body with its activities and all the train of their consequences. Let me be uplifted from the*

earth; let me tread the wine press of the Kingdom.

This is repeated by the Neophyte, following the Hierophant.

Hierophant: *And even as the immemorial soul, may your heart continue to demand the higher things. Honourable Frater Hegemon, in virtue of the sacred testimony which has been borne on his knees by the Candidate, let him be restored to the light.*

The Hegemon unbinds the eyes of the Candidate and the Kerux turns up the lights. The Hegemon repairs to his proper place and the Neophyte remains kneeling between the Pillars, his hand still upon the ground. The Kerux goes to the North, takes the vessel of Salt from the pedestal of the Tablet of the North, and, passing with the sun round the Altar, presents the vessel to the Neophyte.

Hierophant: *Frater Adveniat Regnum (vel alius), the seekers of eternal life are the salt of the earth. Take salt in your left hand, cast it towards the North and say in remembrance of your covenant: Let the mystical powers of earth bear witness to this my pledge.*

This is done accordingly.

Hierophant: *Rise therefore, O Neophyte, an accepted Postulant for advancement to the Grade of Zelator.*

The Kerux, having assisted the Neophyte, replaces the Salt and returns with the sun to his seat.

Hierophant: *With Water from the Wells of Understanding do Thou cleanse us, O Lord, from sin; with Fire from the Altar of Incense, do Thou consecrate us again to Thy service, that we may offer up a clean sacrifice in Thy Holy Place. Fratres Stolistes et Dadouchos, approach in the grace and sanctification of your respective offices; purify the earthly part of our beloved Postulant.*

The Stolistes comes round the Pillars, holds up his Vessel of

Water in obeisance to the Hierophant, turns westward, cross-marks the Neophyte on the forehead and sprinkles three times before him, saying:

Stolistes: *Waters of purification, Waters of the Great Sea, for the cleansing of the earth and man, I purify with water.*

He turns eastward, again elevates his Cup before the Hierophant, and returns to his seat. The Dadouchos comes round the Pillars, holds up the Thurible in obeisance to the Hierophant, turns westward, raises his Thurible before the Candidate, makes the sign of the Cross therewith and censes him thrice, saying:

Dadouchos: *Fire from the Altar which is above; Fire for the consecration of earth and man: I consecrate with fire.*

He turns eastward, again elevates the Thurible before the Hierophant and goes back to his seat.

Hierophant: *The blessing of the Order overshadows you, its welcome awaits you, its God-speed goes before you, as you pass from the gates of the Temple towards the Sanctuary that is within. You have knelt between the Pillars, to lay down the uneasy yoke and the intolerable burden of the old unconsecrated life; you have arisen between the Pillars to the new and dedicated life. Between the Pillars you have been purified and made ready in the sense of the life of dedication; its vistas stretch before you. You stood in the Portal of the .•.•*

at the threshold of our discipline. I bid you lift up the eyes of your spirit, for this is holy ground, and that which lies before you is the path of your attainment and return. Hail unto you, our Postulant and Frater, for your blessed dispositions towards the Light.

*And **Tetragrammaton Elohim** planted a Garden eastward in Eden; and there He put the man whom He had formed. And out of the ground made Tetragrammaton Elohim to grow every tree that is pleasant to the sight and good for food: the Tree of Life also in the midst of the Garden,*

Kerux (answering for Neophyte): *I come from between the mystic Pillars; I seek the way to the heights and the Path of Life in the Name of Adonai.*

Hiereus: *I am Samael, the Great Angel, the Prince of Darkness and of Evil. I am the providence of God in its concealment, trying and sifting the elect, but not beyond their strength. You have called upon the Name of the Lord; return in that Name of majesty: you shall not pass by.*

The Kerux leads back the Neophyte by the same way, that is to say, against the sun, and sets him between the Pillars. The Hegemon rises in his place, with uplifted Sceptre.

Hegemon: *Watch us, going forth and returning; watch us, O Lord, for ever. Let the Neophyte enter the path of Goodness.*

The Kerux leads the Postulant by the South-East and brings him before the Hierophant, who rises with uplifted Sceptre.

Hierophant: *Whence come you?*

Kerux (answering for Neophyte): *I come from between the mystic Pillars; I seek the way to the heights and the Path of Life in the Name of Adonai.*

Hierophant: *I am Metatron, the Great Angel—Angel of the Divine Presence and Indwelling Glory, the Legate of Shekinah. It is not in the law and the order to overleap every thing and attain perfection at once. Your eyes cannot stand its brightness. Return in the Name of the Lord: your time is not yet, and you can not pass by.*

The Neophyte is led back by the Kerux to his place between the Pillars. The Hegemon rises for the third time with uplifted Sceptre.

Hegemon: *Lead us, O Lord, until our death, that we may come alive into Thy Presence. Let the Neophyte enter the strait path, as one of the few that find it. It turneth not to the right or to the left. I have watched long for your coming, O Son of*

*and the Tree of Knowledge of Good and of Evil. And a river went out of Eden to water the Garden, and from thence it was parted and became into four heads. The Tree of Knowledge of Good and of Evil in in the **Sephira Malkuth**, which is also the inferior Garden, wherein are good and evil. For in the correspondence of things which are above with those that are manifested below, there is a Supernal and there is a Lower Eden. The one is the place of our desire and the place whence the influx cometh; the other is that of our purification. From **Gedulah**, or Mercy, there is derived into **Malkuth** the influx of benignity and mildness, on the side of goodness, and from **Geburah** an influx of severity, on the side of evil. The good therein is called the Archangel **Metatron** and the evil is the Archangel **Samael**. It is the Tree of divided Knowledge and it shall be united with the Supernal in **Daath**. But the Tree of Life which stood in the midst of the Garden is that Tree by which **Malkuth** is united with **Binah**. Herein is a great mystery. For the way of the Tree of Life is by the way of Knowledge, and the union with the Supernal in **Daath** is by the middle path which is kept by the Archangel **Sandalphon**. But this allegory of **Malkuth** is also in the mystical sense an allegory of the body of man, above which there is the crown of all life. It is said of the middle path that above it are the Blessed Souls and the Holy Angels, but the **Kliphoth** or demons dwell beneath its roots. So also the permanent part of our nature is above and the shells of wandering thoughts and evil dreams are below.*

The Hegemon rises in his place, with uplifted Sceptre.

Hegemon: *Guide us, O Lord, and guard in all our ways. Let the Neophyte enter the path of Evil.*

The Kerux, with Lamp and Wand, leads the Postulant by the North-East towards the Hieres, who rises with drawn Sword to meet them.

Hieres: *Whence come you?*

Truth.

The Kerux leads the Neophyte up the centre of the Temple and halts at the Western side of the Altar. The Hierophant and Hiereus rise together and turning inward join their Sceptre and Sword over the Altar, saying together:-

Hierophant
: *Whence come you?*

Hiereus

Kerux (for Neophyte): *I come from between the mystic Pillars; I seek the way to the heights and the Path of Life, in the name of Adonai.*

The Hegemon rises and between the Sceptre of the Hierophant and the Sword of the Hiereus he thrusts his own mitre-headed Sceptre, raising it to an angle of * *. He thus parts them asunder with the Sign of the Grade.

Hegemon: *I am Sandalphon, the Great Angel; I am the left-hand, feminine Kerub of the Ark, as the Hierophant is the male Kerub on the right hand. I rise in the place of Benignity. I come from before the Golden Mercy-Seat. I am the Preparer of the Way which leads to the Celestial Light. Peace and reconciliation are in my hands. I have the power and will to save all who shall enter by the middle path of prudence. I have seen the Tree of Life and the twelve manners of fruit. Make way for me, ye Lords of Truth; I carry the grace of mediation, and before I have finished my course I look to make all things one.*

The Hierophant and Hiereus resume their seats South and North of the Altar respectively. The Hegemon remains standing.

Hegemon: *And Tetragrammaton Elohim placed at the East of Eden Kerubim and a Flaming Sword, which turned every way to keep the way of the Tree of Life. Frater Adveniat*

Regnum (vel alius), from Malkuth, which is the tenth Sephira, the manifested world, the incorporation of man's spirit in flesh, there extends a middle path, and it is the way of your return to the height. It is the path of Equilibrium between the Evil and the Good, and at some far point thereof the Tree of Knowledge shall become the Tree of Life. We have told you concerning that Tree in the middle of the mystic Garden, of the original condition of man when the Divine Substance was continually communicated to his soul. You know that he was sent forth into exile and since that strange prenatal time has been the denizen of an inferior garden. But the vestiges of the old transcendent state have not been removed utterly. The scattered fragments of the Divine Food allure him still in his exile; they are administered in the sacraments of Nature and Grace for ever and ever; they are the aids and consolations accorded to him in the way of his return homeward; they are the sanctities of the path of his redemption. Remember therefore, O Frater, whence you have come; remember whither you are going: lift up your eyes and know that salvation is continually at hand.

The Hegemon resumes his seat. The Hierophant rises to confer the secrets of the Grade as follows:

Hierophant: *Receive now the official secrets which are reserved to the Grade of Zelator. They consist of a Step, Sign, Grip or Token, a Word, a Mystic Number and a Pass-Word formed therefrom. The Step is taken * * * *. It indicates that you have crossed the Threshold. In this position extend * * *. This is the Sign of the Grade, and it commemorates the manner in which the **Hegemon** interposed for your assistance between the Hierophant and Hiereus, acting as guardians of the paths. The Grip or Token is exchanged by * * *. This is the distinguishing grip of the First Order. The Word is * * *, signifying * * * *, and refers to the **Queen of the Earth**, to which element this Grade is attributed. The Mystic Number is * * *, and from it is formed the Pass-*

*Word * * *, meaning Ornament. It is to be lettered separately when given. The Badge of this Grade is the Ribbon of the Neophyte, with the addition of a Red Cross within the triangle, and the numbers 1 and 10, within a circle and a square respectively, left and right of the apex of the triangle.*

The Hierophant invests the Neophyte with the Ribbon and continues:

Hierophant: The three Portals in the East are the Gates of the Paths leading to three further Grades which with those of Zelator and Neophyte constitute the first and lowest circle of our Fraternity. They also represent the Paths which connect the Sephira Malkuth with the Sephiroth which are above. The Portals are inscribed in their centres with the Hebrew letters, Tau, Quoph and Shin, being the consonants of the mysterious word Quesheth, which signifies a bow. It is a reflection in things beneath of that rainbow which is said, in another form of symbolism, to encircle the Throne of God. It refers also to the Quest of the Self-Knowing Spirit in the path of manifestation and to the Eternal Covenant between the Divine in man and the Divine in the Universe by which there is, world without end, a path of return to God.

The Hierophant resumes his seat. The Hegemon rises in his place and comes round to the West of the Altar.

Hegemon: The Flaming Sword of the Kerubim is represented by the most simple outline of its symbolism in the diagram before you. It has however a much deeper meaning than that of the symbolic weapon which kept the way of the Tree of Life. Frater Adveniat Regnum (vel alius), may God be with you in your Quest, and seeing whence you have come down, may His own wisdom teach you the most practical of all lessons—which is how to go back.

The Hegemon returns to his place. The Hiererus rises from his seat and faces towards the Altar.

Hiereus: *In the Grade of Neophyte the Red Cross was placed at the apex of the White Triangle upon the Altar, but is placed within it in this Grade, to symbolise the Divine Life abiding in the Divine Light. When the Light of the Spirit is declared, my Brother, in your consciousness, may the Life be communicated to you therein.*

He resumes his seat. The Hierophant rises in his place to indicate the Tablet of the North.

Hierophant: *The Grade of Zelator is referred in our mystical symbolism to the element of earth, and one of its emblems is called the Tablet of Earth, the Northern Quadrangle and the Great Watchtower of the North. It is one of the four Elemental Tablets said to have been entrusted by the Holy Angel Ave to that patriarch **Enoch** who walked on earth with God, until a day came when he was not, for God took him. The Tablet contains Divine and Angelical Names referable in symbolism to the Northern Quarter of the heaven and by correspondence to the element of earth. They serve to remind us that the universe and man who dwells therein are encompassed on all sides by the powers and the providences, the graces and the blessings of the Divine; they are part of the Eternal Covenant that He has given His Angels charge over all those who work for the Hidden Wisdom and follow the Quest of Him.*

The Hierophant resumes his seat. The Kerux comes forward and hands the Fylfot Cross to the Hierophant.

Hierophant: *The Hermetic or Fylfot Cross is a great astronomical symbol which speaks to those who can interpret concerning concerning the Divine in the universe. It is formed of 17 squares extracted in a peculiar manner from a square of 25 squares. Observe that the Sun is in the centre and that it is surrounded by the four elements and the twelve zodiacal signs. You also are a centre in the universe; let your light shine before it. You are a centre of your own system; let the light of your consciousness be poured over your elements,*

over the parts of your personality, over your seals and characters and signs. As a memorial that you have left the darkness, that you look for the sun of justice to rise in your soul, the veils have been removed from the lights on the summits of the two Pillars.

A pause.

Hierophant: Frater Kerux, *you have my commands to conduct the Zelator from the Temple, which he will afterwards re-enter amidst the symbolism of another stage of his progress.*

The Kerux leads the Neophyte to the door. The Kerux and Neophyte (who is prompted) give the Sign of the Grade, and they leave the Temple. The Kerux returns immediately.

Here ends the First Point.

The Second Point

The arrangement of the Temple is shown in the Official Diagram.

Hierophant-1--: Fratres et Sorores, *having been reminded of whence he came and whither he returns, our beloved Neophyte and Postulant for Advancement in this Grade has left the Temple, and he will find it transformed on his return, as if to a place of external religion, a Holy Place, with a Holy of Holies beyond it, behind which there is an inner religion, but its mysteries are not communicated to him in this Grade. . . . Honourable Frater Hegemon, may God be with you for ever. Assume your ministries of mercy, in the performance of which you represent in the world of Assiah the glorious loving-kindness and benignity descending from the Supreme Crown through the unmanifest and manifest worlds.*

The Hegemon rises in his place and makes the Sign of the Grade.

Hegemon: *I will take unto me the strength of the Eagle; I will*

unfold the wings of the Dove; and all who desire in their hearts the graces and lights which abide in the Holy Place, I will bring unto the Mercy-Seat and the rest of the Eternal Sabbath.

The Hegemon leaves the Temple.

Hierophant: Frater Kerux, *when the Neophyte, under gracious guidance, gives the symbolical battery of the Grade, signifying his obedience to the Law, you will admit him according to form. Fratres Stolistes et Dadouchos,* *follow with your mystic vessels and perform your holy part in the consecration of the Neophyte for the last time in the solemn ceremonies of the Temple.*

The Kerux rises in his place. The Stolistes joins the Dadouchos in the South, and they proceed together to the West, where they follow the Kerux to the door. The battery being given as follows:-1111 111 II I—the Kerux opens the door.

Hierophant: Frater Adveniat Regnum (vel alius), *you were admitted in the Grade of Neophyte through the Portal of a Holy House, typically represented by that place of God which was built of old in Israel. You came already into the precincts thereof, even into the Court of the Tabernacle, where stood the Altar of Burnt Offerings, on which animals were immolated in sacrifice. It is an image of that greater Altar whereupon the Archangel Michael sacrifices the souls of the just.*

The Dadouchos makes a Cross with his Thurible in front of the Neophyte and censes thrice.

Dadouchos: *When his earthly part has been burnt to ashes, the spirit of man shall ascend, as the sparks fly upward.*

Hierophant: *Between the Altar of Burnt Offerings and the entrance to the Holy Place stood the Laver of Brass, wherein the priests washed before they entered the Tabernacle. It was a symbol of the Waters of Creation. Remember, O*

Frater, that through the fires and waters of this earthly life we are prepared for the things that are of heaven.

The Stolistes marks the Neophyte with a Cross on his forehead and sprinkles thrice.

Stolistes: Purify the earthly part, O Lord: purge away the old leaven: sanctify the acts of man.

The Hegemon returns to his seat and the Kerux takes charge of the Candidate.

Hierophant: *Having made his offering at the Altar of Burnt Sacrifice, having been cleansed in the Laver of Brass, the Priest then entered the Holy Place. From earthly into spiritual life, from the places of lesser purification, come into the place that is holy; enter into the presence of God.*

The Kerux stations the Neophyte at a short distance behind the Pillars with his face to the East. The Stolistes and Dadouchos return to their seats. The Hiererus proceeds with the sun round the Black Pillar, and stands between the Pillars, facing the Neophyte, guarding the Path with his Sword.

*Hiererus: Purified in the earthly part, consecrated in the manifest body, O Neophyte of the ' . . * , give me the signs of the Neophyte. They are the title of your passage through the gate.*

The Signs are given. The Hiererus returns to his Throne. The Kerux leads the Candidate between the Pillars. The Hegemon, coming forward, stands East of the Pillars and bars the way of progress with his Sceptre.

Hegemon: I come from the Mercy-Seat; I come in the Name of the Light. You who are zealous of the Light, you whom I will lead into its glory, show me the warrants that you bring; give me the Sign of a Zelator.

It is given accordingly. The Hegemon draws the Neophyte between the Pillars. The Kerux returns to his seat.

Hegemon: *I will lead you, I will bring you, into the House of Light.*

The Hegemon takes the Zelator to the North.

Hegemon: *The Table of Shewbread stood on the Northern side of the Holy Place, and the Twelve Loaves placed thereon were emblematic of the Bread of Life. Some part of its secret meaning is shown in the diagram before you. The 12 external circles represent the mystic loaves, and the Lamp in the centre is the grace and life and light by which the material nourishment of man may be changed into the food of souls: it is the power behind the Sacraments. In another sense the diagram represents the Rose of Creation, the universe of manifested things and the Divine Immanence which abides like a secret light within it. The 12 circles are referred to the 12 simple letters of the Hebrew alphabet, and these also typify the Divine Elements by which all creation is permeated. They signify further the 12 directions of space, the 12 constellations of the Zodiac, the 12 permutations of the Sacred Name of God and the 12 tribes of Israel, representing those who have been called and chosen, out of all tribes and tongues and peoples and nations, for the mystic work in the world. Finally, the circles compose the crown of 12 stars on the head of Adonai Malkah, the Mother in manifestation, ruling in her kingdom of Malkuth. They are the outer petals of the Rose. Within the 12 circles are 4 interior circles, containing the Kerubic emblems—the Lion, the Man, the Bull and the Eagle, which are in correspondence with the 4 parts of our natural personality. In this sense the Lamp, standing on the Pentagram, represents their transmutation and quintessence. You should understand in conclusion that, the explanation of every thing being within and not without us, the Rose of Creation is also the Rose of our humanity, and the Lamp in the centre of the diagram is the higher consciousness. Man is thus the explanation of every thing, and the key to this mystery is that God is within.*

The Hegemon takes the Zelator to the South, where he is joined by the Hieres. The Hegemon *resumes* his seat.

Hiereus: *The Seven-branched Candlestick stood on the Southern side of the Holy Place, and it is represented here in a diagram by the mystic star of the Heptagram. It is in correspondence with the Seven Palaces of Assiah, or the material world, and with the seven double letters, signifying the Divine efficacy therein, by which the Palaces of **Assiah** become the Holy Place. This place is the glorious Palace of Holiness, represented by the Lamp in the centre. The Seven-branched Candlestick is also in analogy with the Seven Churches of Asia, and even as the branches of the light-bearer are bound together, springing from one root and one stem, so are the Seven Churches one Holy Church of the Elect. And as the Angels of the Churches are Stars for the enlightenment thereof so is there a mystic lesson in the seven planets and in the days of the week. For the days are like Seven Churches, and it is yours, O Elect Frater, through the week of your earthly life, so to consecrate and rule your life within them that they shall be one Church and one most Holy Temple, with God dwelling therein. Thus shall you deserve to be crowned at the end of all with that chaplet of Seven Stars which are the gift of the Spirit.*

The Hiereus conducts the Zelator to the West of the Altar, whither the Hierophant comes. The Hiereus returns to his seat. The Dadouchos lifts up his Thurible, which is taken by the Hierophant, who makes a Cross in the air therewith and offers incense thrice.

Hierophant (at the first censuring): *Glory be to God, Who is declared in the heart of man to those who are pure in heart. (At the second censuring.) Glory be to God, Who is manifested in the light of created things. (At the third censuring.) Glory be to God in the Transcendance, in the place of concealed mystery. We adore Thee in the presence of the veil. O take us in Thine own good time, Thy gracious and saving time, beyond all veils, behind Thy palms and pomegranates, into the Holy of Holies.*

A pause.

Hierophant: *Before the Veil of the Holy of Holies stood the golden Altar of Incense, of which this is an image. It stands in the middle place of our Temple and is in the form of a double cube, presenting the surface of things to the eye of sense but concealing the root and the source, as He is concealed in the universe Who is Author and Cause of all. The Altar of Incense was gold because of the Quintessence, but this altar is black because of the corruptible elements from which the Quintessence is extracted, because of the Divine Darkness, because we await transmutation, and because the witness of Nature to Grace is a witness in the night of time. Upon the Cubical Altar were Fire, Water and Incense, corresponding to **Aleph, Mem and Shin**, the three Mother letters of the Hebrew alphabet. The divisions of this alphabet, of which you have heard briefly in connection with the Table of Shewbread, the Seven-branched Candlestick and the Altar of Incense, are but a part of the deep symbolism which lies behind the letters of the word of man—itsself a shadow and reflection of that Eternal Word which is concealed everywhere, but is declared in the secret heart. From the throne of your imperishable spirit, **O Frater Adveniat Regnum (vel alius)**, may the Triad and the Unity therein look forth upon the Kingdom which is yours; may the seven spirits and the seven graces encircle it; and may the twelve fruits of the Tree of Life ripen in your external part.*

The Hierophant returns to his Throne, the Zelator remaining at the Altar.

Hierophant: *I now confer on you the Mystical Title of **Pereclinus de Faustis**, which signifies that on this earth you are as in a wilderness far from the garden of the soul. As it is also the name of those who have come out from the life of earth, seeking the light of the Spirit, I give you the symbol of **Aretz**, which is the Hebrew name of Earth. The word **Zelator** has been sometimes referred to the ancient Egyptian **Mr' athor**,*

signifying Searcher of Athor, the Goddess of Nature. May you so seek, my brother, that through Nature you shall enter into Grace. May you be worthy of your high calling. May you come with joy and go forth in gladness. May God Himself guide you, if haply our steps fail in the path which leads to the heights.

The Kerux comes forward and conducts the new Zelator to a seat in the North-East.

Hierophant-1--: *Frater Kerux, lift up your Wand of Office; lift up the Light that you carry; and declare in this Holy Temple that our **Frater Adveniat Regnum (vel alius)** has been advanced to the Grade of **Zelator** and has received, by a regular communication, the titles conferred therein.*

Kerux: *The Name of **Adonai** is before us; The Name of **Malkah** is before us; the Lord of Earth, the Bride and Queen of the Kingdom: Truly Honoured Hierophant, in those names and obeying your high ordinance, I proclaim that **Frater Adveniat Regnum (vel alius)** has been regularly admitted to the 1=10 Grade of **Zelator** and has received the **Mystic Title of Pereclinus de Faustis**, with the symbol of **Aretz**.*

He salutes the East in passing and returns by West to his seat.

Hierophant: ***Malkuth** is a place of the darkness, a place of the shadowed light, a place of illumination in Holy and Secret Sanctuaries. The powers and the glories, the mercies also and the graces, through the paths and worlds of the **Sephiroth** above, are sent down therein. It is the first **Sephira** in the way of our return whence we came, and it is therefore called 1 in our system. But seeing that on the outward path, by which the spirit of man travelled into manifestation, it is the tenth and last **Sephira**, so also its number is **10**, and it is in this sense that the Grade to which you have been advanced is described as 1=10. As it is a path which takes into manifestation, so it is a gate which leads therefrom. It is therefore termed **Shaar**, which signifies gate, and this*

*word produces by metathesis another word **Oshr**, which signifies **the** number 10. In Chaldaic a gate is **Throa**, the numeration of which is identical with the Holy Name **Adonai**, when the latter is written at full length.*

*The Tenth Path of the **Sepher Yetzirah**, or **Kabalistic Book of Formation**, is referred to the **Sephira Malkuth** and is termed the **Resplendent Intelligence**, because it is exalted above every head and is enthroned finally in **Binah**, or the sphere of **Supernal Understanding**. It is the root and the fountain of light, the splendour of all illumination, and thence is derived that **Divine Influence** which descends from the **Prince of Countenances**, the **Great Angel Metatron**.*

A pause.

Hierophant: Frater Adveniat Regnum (vel alius), *your title to further advancement in the Grades of the Order will continue to depend upon the maintenance of the Holy Fire which your aspiration has enkindled within you. Guard therefore that fire, as we on our side will guard your memory in our hearts; and be sure that when you come again to our Temple, carrying the proper warrants, asking in humility and reverence for tidings of the Holy of Holies, we shall hear your voice, and when you knock we shall surely answer.*

Here ends the Second Point.

The Allocution of the Grade follows, and may be delivered by the Hierophant or one of the Wardens of the Thmple.

The Allocution of the Grade of Zelator

Fratres et Sorores, *by the faithful witnesses whose counsels have been transmitted from of old, we know that the Tree of Life is united to the Supernals in **Daath**. In some high region of the mind, above the distinctions which obtain between good and evil, and merged in the absolute goodness which fills the soul entirely, there is an union which the soul attains, so that knowl-*

edge is on all sides, and is infinite and holy. I invite you, therefore, to hear in the repose and the stillness which follow each stage of activity, marking our progress in the work, the Allocution belonging to the Grade of Zelator. And you, our Postulant, who have this day crossed that threshold to which you were brought only in the previous degree, I solicit and claim your attention to a few salutary inferences which should be taken away from the experience through which you have just passed, being that of the advancement which follows reception into the House of Our Order. Here, as in other departments of intellectual and spiritual life, advancement is in virtue of knowledge extended slowly. It corresponds to the partial communication of that light which in the Grade of Neophyte we desire may be extended to the Postulant and increased within him. He is now pictured as having reached the outer side of that Portal which is called Wisdom, and if it be only in symbolism that he has earned the title for it to be opened at his knocking, he is still instructed to knock, and what follows is that it does open. He enters amidst the harmonious rumours which move about the building of the Mystic House and of the Spiritual City; his face is set towards the East, as one who should see Zion on the sacred hill when the Orient from on high has flooded it, when the night and its shadows are over. But the Postulant for the Grade of Neophyte comes in darkness to the threshold and in the Court of the Holy Temple his eyes are opened for a period. They close again in the Grade of Zelator, because of the unknown heights, but it is for a moment only, and again they are now opened. Let us pray that for him and those who are like him all folds and scales and bandages may fall from the inward eyes and that there shall be no more darkness within.

The symbolic experience through which the Postulant passes in this Grade is that of the middle path, as between good and evil or light and shadow. The Angel of the Evil Path, as the protector against that evil which is within him, has told him that he shall not pass by, for his own pledges forbid him. But the Angel of the Perfect Path tells him that he cannot proceed, seeing that he enter only in the likeness of the natural man, as yet unquali-

fled further. That which is open to him is therefore the Path of Equilibrium, and it takes him to the East, which symbolises spiritual knowledge. Thence the Postulant looks, from his base on this earth, towards the City which is beyond, or the House of his desire, and he sees the great distance stretching before him—an immeasurable distance which he is prepared to enter. He knows also, or may at least divine it, if he have brought within the circle of our Order something of the light of thought, that distances of themselves are nothing, nor do places signify, because that which we reach in the height is already here. There are no greater opportunities than those of to-day; there are no hindrances so insuperable that will and desire cannot in their transmutation, and with their changing power, convert them into perfect paths. When, therefore, the Postulant looks toward the East of the Temple, when the voice of the Hierophant speaks to him of Great Mysteries, of the Tree and the Garden, he knows that these things are also here and now, that Malkuth is the Kingdom, that the Kingdom is also a Garden and the Paradise that is below, while the Tree is not separable from these. Fratres et Sorores, here is the way of the Tree of Life, now is the call thereto, and if some swords are broken at the entrance-gate, if for some the Sword of the Kerubim keep that way too keenly, there is also a Sword of the Spirit, before which even the Kerubim raise their guard, so that those who are born for the Sanctuary may enter and go in. Here ends the First Point.

The symbolism has changed in the Second from that of the Garden of Eden to the Mysteries of the Holy Place, of the Spiritual House manifested on this earth—this earth enlightened by a material sun, itself the sphere of the elements, encircled by the belt of the Zodiac. For the earth is the gate of the Holy Place, and the Holy of Holies is manifested therein for those who are qualified to enter. Whether we are conscious or not of His Divine Presence, the Reconciler is always with us, speaking from the Mercy-Seat and preparing the way to the Celestial Light. In such a Temple, my brethren—at once manifest and concealed—you are the burnt offerings; you are also the altar; it is by the sacrifice of your proper selves, and so only, as in a great purgation

*and cleansing, that you can enter truly and essentially the Holy Place which you have now entered symbolically. There is the Bread of Life, which is shown in our symbolism to correspond with the whole of creation, because God nourishes His children, substantially and supersubstantially, on all the planes, and the high angels, which guard the inmost precincts of the Mysteries, do communicate—to those who can receive—the Food of Souls, in every region of the universe. In that Temple also are held, as if in archives, the hidden doctrines of the Divine Mystery, leading by steep paths to the Crown and Quintessence of all Experience in the term of sanctity. But you should note that it is out of the corruptible earth that the true Quintessence is extracted, showing that the way of your election—the path of life to which and in which it has pleased God to call you—is for you the nearest way. After this manner does the mystic Temple contain all things symbolically. But **Malkuth** is also the Temple, and the Mystery of the Tenth Path, about which you have just heard, shows that **Malkuth** is understood after more than one manner, because that which is begun on earth is completed in Heaven. There is, lastly, a certain state of mind by which an intelligence that is other than the logical understanding—which is more resplendent and more highly enthroned—descends through an ordered channel, as a light of the Prince of Countenances. And this channel is that Path by which the **Zelator** goes up.*

If the Minutes of any previous Meeting or other official business are to be taken in the Grade of Zelator, the Temple must be reduced at this point to the Grade of Neophyte. By the power of his Sceptre, the Hierophant must close in the higher Grade, open in the lower, and, after the business has been completed, must close therein and reopen in the Grade of Zelator.

The Solemn Office of Closing the Sacred Temple in the Grade of Zelator

The Sentinel having left the Temple:

Hierophant-1—

All rise.

Hierophant: *Fratres et Sorores Zelatores, I beseech you to assist me with one mind in the closing of the heart against the world.*

Hiereus: *Truly Honoured Hierophant, I testify on behalf of the Brethren, I testify on my own part, that the heart is guarded.*

Hierophant: *Let that which is watched within, even in the sacred precincts, be protected also beyond, in the world to which we return. . . . Frater Kerux, remembering the correspondence between things within and without, I direct you to see that the Temple is properly secured.*

The Kerux knocks once on the inner side of the Portal, and is answered after the same manner by the Sentinel without.

Kerux: *Truly Honoured Hierophant, that which is symbolised on the hither side of the Portal is reflected on the further side by diligent, external guarding.*

Hierophant: *The earth is full of His goodness; the pillars of the earth are the Lord's; the earth is full of His riches: let us adore the Lord and King of Earth.*

The Hierophant descends from his Throne and faces East. He extends his Sceptre on high in the Sign of the Grade. All face East and maintain the Sign.

Hierophant: *Adonai-Ha-Aretz, Adonai Malkah; we have desired Thee in all generations. Spirit of the Lord, say: Come; Bride of the Lord, say: Come. We have watched in the night because of Thee: we have worked in the day because of Thee:*

we die in the endurance of our longing: make us alive in Thee. 0 earth, earth, earth; part of the earth in us; hear the Word of the Lord. Amen.

The Hierophant passes to the North, and pauses before the Tablet of the North. All face to that point. The Hiererus takes up his place at the right of the Hierophant and the Hegemon on his left hand. The Kerux stands behind the Hierophant, the Stolistes behind the Hegemon and the Dadouchos behind the Hiererus, carrying their respective implements of Office.

Hierophant: *Let us offer the mystic prayer of the Earth-spirits, typifying the powers and activities of our own material part, aspiring towards the Great Master.-1—*

The Prayer of the Spirits of Earth

0 King Invisible, Who, taking the Earth for a foundation, didst hollow its depths to fill them with Thine Almighty Power! Thou Whose Name shaketh the Arches of the World; Thou Who causest the seven metals to flow in the veins of the rocks; King of the Seven Lights; Rewarder of the subterranean workers; lead us into the desirable air, into the realm of splendour. We watch and we labour unceasingly; we seek and we hope; by the Twelve Stones of the Holy City; by the Buried Talismans; by the axis of loadstone which passes through the centre of the earth! 0 Lord! 0 Lord! 0 Lord! Have pity on those who suffer, expand our hearts, unbind and upraise our minds, enlarge our natures! 0 Stability and Motion! 0 Day clothed with Night! 0 Darkness veiled by Splendour! 0 Master, Who never dost withhold the wages of Thy workers! 0 Silver Whiteness! 0 Golden Splendour! O Crown of Living and Melodious Diamonds! Thou Who wearest the Heaven on Thy finger as a sapphire ring; Thou Who concealest under the earth, in the kingdom of precious stones, the marvellous seed of stars; Live; Reign; and Be Thou the Eternal Dispenser of the treasures whereof Thou halt made us the Wardens. Amen.

The Hierophant makes the Banishing Pentagram of Earth.

Hierophant: *Depart in the peace of the Everlasting; depart to your proper places, your paths and grades and activities. The graces and benedictions of Adonai be upon you, and be you ready for the call of His service.*

All Officers return to their places and all face as usual.

Hierophant: *Our hearts are licensed to go forth into the outer world, carrying the memorials of the covenants made within. In the name of Adonai, I declare this Temple closed in the Grade of Zeal and Aspiration.*

Hierophant-1111 111 111—

Hiereus--1111 111 111—

Hegemon-1111 111 111

Here ends the Ritual of the Grade of Zelator.

Bibliography

Bullinger, Ethelbert W. *Witness of the Stars.* Grand Rapids, MI: Kregel Publications, 1972.

*Jung, C. G. **Mysterium Coniunctionis.*** Princeton, NJ: Princeton University Press, 1970.

le Plongeon, Augustus. *Sacred Mysteries Among the Mayans and the Quiches.* San Diego, Ck. Wizards Bookshelf, 1973 (original ed. 1886).

Lost Books of the .Bible & the Forgotten Books of Eden. New York: New American Library, 1948.

Regardie, Israel. *The Golden Dawn.* St. Paul, MN: Llewellyn Publications, Inc., 6th ed., 1989.

Regardie, Israel. *The Complete Golden Dawn System of Magic.* Phoenix, AZ: Falcon Press, 1984.

Zalewaki, Patrick J. *Secret Inner Order Rituals of the Golden Dawn.* Phoenix, AZ: Falcon Press, 1988.

Zalewski, Pat. *Golden Dawn Enochian Magic*. St. Paul, MN:
Llewellyn Publications, Inc., 1990.

Zalewski, Pat. *Z-5: Secret Teachings of the Golden Dawn—Book I:
The Neophyte Ritual 0=0*. St. Paul, MN: **Llewellyn Publications,
Inc., 1991.**