

THE MYSTERY OF THE LETTERS
AND THE TREE OF LIFE

THE MYSTERY OF THE LETTERS AND THE TREE OF LIFE

INTERRELATIONSHIPS AMONG SYMBOLS
IN THE ÆON OF THE CHILD

by

ROBERT C. STEIN



Black Jackal Press
York Beach, Maine
2012

Do what thou wilt shall be the whole of the Law.

Liber XXXI, Chapter I, p. 10-11

Liber XXX vel Liber Librae

5. Yet, oh aspirant, let thy victories bring thee not Vanity, for with increase of Knowledge should come increase of Wisdom. He who knoweth little, thinketh he knoweth much: but he who knoweth much hath learned his own ignorance. Seest thou a man wise in his own conceit: There is more hope of a fool, than of him.
6. Be not hasty to condemn others; how knowest thou that in their place, thou couldst have resisted the temptation? And even were it so, why shouldst thou despise one who is weaker than thyself?

Liber XXXI vel AL

III: 17.

Fear not all; fear neither men, nor Fates, nor gods,
nor anything. Money fear not, nor
laughter of the folk folly, nor any other power
in heaven or upon the earth or under the
earth. Nu is your refuge as Hadit your
light; and I am the strength, force, vigour of
your arms.

TABLE OF CONTENTS

Apologia	ix
Acknowledgments	xi
Preface	xiii
Chapter I. Introduction — The Æon of the Child	1
Literary basis and definitions	
Chapter II. Messages and Models	23
Chapter III. Liber XXVII vel Trigrammaton	34
Cube of Space — Trigrams	
Quantum Tree — Sephiroth	
Chapter IV. Liber XXXI vel AL	74
Mystery of the Letters, Tree of Life paths	
Chapter One — The Glyph	74
Chapter Two — The Riddle	84
Chapter Three — The Line and Circle Squared	119
Chapter V. Liber CCXXXI vel Atus of Tahuti	124
Chapter VI. Alphabets	198
Hebrew Qabalah	
Greek Kabbalah	
English Kabbalah	
Chapter VII. Epilogue	211
Bibliography	216
Appendices	
I. Quantum Tree Sephiroth & Path Correspondences	227
II. Liber XXXI Ch. III: 1 analysis	230
III. Liber V vel Reguli formulas	236
IV. Tarot as an Initiatory Sequence	246
V. Ritual Beth-2 (adapted for individual use)	247

ILLUSTRATIONS

Frontispiece:

The Quantum Tree model, Lower and Upper Phases.

Plates between pp. 98 & 99

- Figure 1. The Cube of Three viewed from above.
- Figure 2. The Cube of Three viewed from below.
- Figure 3. The Cube of Two viewed from above and below.
- Figure 4. The Cube of One, comprising Malkuth and Assiah.
- Figure 5. The Cube of Three from below.
- Figure 6. The 3-d Quantum Tree of Life, non-helical form.
- Figure 7. The 3-d Quantum Tree of Life in Lower Phase.
- Figure 8. The 3-d Quantum Tree of Life in Upper Phase.
- Figure 9. The components of the 3-d Quantum Tree of Life.
- Figure 10. The 3-d Quantum Tree of Life viewed from Malkuth.

APOLOGIA

WHERE one starts is where one ends but in a different manner. One begins with nothing, and ends with Nothing. In between, is illusion—a glimmer of what is truth.

After chasing around the world for several years looking for answers to the four questions of initiation, I found answers within a few miles of where I was born, and even within myself.

The four questions are:

Who am I?
Where do I come from?
Where am I going?
What am I looking for?

The answer to each of these questions is clear: “I don’t know.” If I knew the answers, I probably would not have chased around the world.

I was born in the 27th year of the Æon of the Child, in the year of the Emperor. I graduated from high school the month after Crowley died. As a scientist, I found Thelema many years later. I publish this in the year of the Sun (IVxix A. L.). The Æon and the Universe lie ahead.

At Khephra Camp of the O.T.O. in Brooklyn NY in the early 1980’s, I formally recognized Thelema. After doing my first ritual in Camp, I came out thinking to myself “What is all this rubbish?” (I had interpreted the ritual quite literally, rather than symbolically.) Somehow, though, I stuck with the system, and found some answers for myself. Many answers came from exploration and a growing appreciation of the symbolic way to transmit truth—call it initiation. Some certainly came from exploring logic that adds meaning to the symbolism, and some from my initiators—call it aspiration.

Now, some 30 years later, I find myself regularly doing an adaptation of Crowley’s Ritual Beth-2. This is an invocation to knowledge, to Ra-Hoor-Khuit, and to Tahuti (= Mercury, Minerva, Athena, the “wise owl”). They symbolize ways of attaining knowledge, understanding and wisdom. The

Beth-2 ritual ends with an invocation to Khephra who symbolizes the original light in darkness in the North. This relates to Hoor-Paar-Kraat. In the east, Ra-Hoor-Khuit (in his secret name and splendour) is the Lord initiating, the bringer of light into the current æon. United, Ra-Hoor-Khuit and Hoor-Paar-Kraat are Heru-Ra-Ha, Horus the Child—hence the name for the Æon.

Khephra symbolizes the darkness, the chaos that precedes God saying in Genesis I: 3, “Let there be light.” (The beetle rolls a ball of dung from which hatch larvae, symbolizing light.) That light first appears in the east, at dawn. The Greek word Helios (*ἥλιος*) symbolizes it. So does Ra-Hoor-Khuit.

So, I return to the origin in Khephra. It must be that what I search for is always in and around myself, though I may not perceive it. One becomes Minerval again, accepts that which is within, and how that relates to the big picture.

ACKNOWLEDGMENTS

Since 1982 or 1983, I have received initiation at different levels from many recognized and leading Thelemites. They have provided guidance, knowledge and support. I have added historical data with information from the Golden Dawn, the O.T.O. and A.'. A.'. curricula. Above them all, I put particular emphasis on the Class A material of Thelema. I have tried to follow, without change, the directives concerning the original texts. I include the rationale behind my views. I am solely responsible for the conclusions.

To those named below I express my particular thanks and appreciation. They may not agree with my interpretations, or vice versa, but I acknowledge their contributions. I anticipate further discussion. In alphabetical order, they include:

To my initiators: William Breeze, James Eschelman, Kent Finne, Richard Gernon, Dan Gunther, Michael Kramer, David and Lynn Scriven, Phyllis Seckler and James Wasserman.

In recent times, I have had contributions and discussions with a wide range of colleagues who have challenged my ideas and presentation:

Particularly I acknowledge my long-term friend, Norman Fleck, who more than 25 years has been a loyal critic and one striving for clarity in my presentation.

To Pyramid Lodge, O.T.O., for many discussions and patience in analyzing Thelemic literature and symbolism, including particularly: Keith Bergeron, Rob and Sabrina Caine, Michael Kolson, August La Scola.

To those outside that Lodge: Krzysztof Azarewicz, Justin Bunn, Richard Kaczynski, Bjørn Løken, Cassie Tsiris, and many others.

To: James Strain, especially, for his sharp editorial eye and ideological criticism.

And last, but far from least, to Alice Stein for her untiring patience and support over so many years. She demonstrates how the principles of Thelema operate beyond any "official" organization.

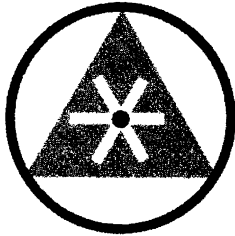

PREFACE

THELEMA is a system of magick and mysticism identified with the Æon of the Child, Heru-Ra-Ha. Its initial message was revealed and received in 1904 in the manuscript *Liber L, The Book of the Law*. Like most books of the sort, the message is encrypted in symbols—symbols with historical meaning, but subject to interpretation. With the New Æon, these symbols often take on new meaning.

Liber L is the ultimate unchangeable authority for Thelema. Additional books (“*Libers*”), especially those considered “Class A,” carry high, but subordinate authority, and are not subject to change. Material of lesser import does not have that characteristic. However, they do have a consistent set of symbols.

The present study attempts to show the inter-relationship among symbols in Class A *libers*, and how these symbols may be interpreted. The Tree of Life is a basis for correlating and comparing symbols from different systems. As should be expected, in the new Æon of the Child a change in perspective changes some old ideas. As it says in *Liber XXXI II: 5*:

Behold! The rituals of the old time are black.
Let the evil ones be cast away; let the
good ones be purged by the prophet! Then shall
this knowledge go aright.

Liber XXVII, Trigrammaton presents a different viewpoint about the Cube of Space model and the three-dimensional Quantum Tree of Life model. It particularly describes the sephiroth in each.

Liber XXXI, The Book of the Law, includes the Mystery of the Letters. The letters relate to the paths on the Tree of Life, including the Quantum Tree. They index clues to many of the correspondences among magickal and mystical systems. The unraveling of the Mystery is key to understanding the message of the Æon. The transmission of the Word is stressed in *Liber XXXI*. It is easy to distort. The directions for spreading that Word are explicit. The underlying warning here is: *Study the manuscript. It is the charter of individual and universal freedom.*

Liber CCXXXI, The Atus of Tahuti, further explains the message of the paths. It is limited to the 22 Tarot trumps, and considers several aspects as a path of initiation.

The correlation of these may provide a better understanding of words, symbols, and rituals. The goal is to encourage Thelema, a new and distinctive view of the relationship between a man and his universe.

A man comes into this world knowing nothing about everything. He leaves it knowing everything about nothing. In between, all he can hope for is a glimmer of the reality behind the illusion and the symbols. You hold in your hand a report on one Fool's errand, the result of a Fool in his folly, a Minerval, and an aspiring "wise old owl." The owl hoots from the darkness.

30 March 2011 *e.v.*

CHAPTER I - INTRODUCTION

THE phenomenon of what we call the Æon of the Child, Heru-Ra-Ha, was revealed in a message by the voice of an Angel to man. Begin at the beginning.

We are fortunate to have the original physical record of that dictation, taken on 8-10 April 1904, written down by Aleister Crowley, who became the prophet of that Æon. The facsimile of the first page is shown here:

1
Had! The manifestation of Meit
The mediating of the company of beaver
Every man and every woman is a star
Every number is infinite: there is no difference
Help me, O warrior Lord of Thebes, in my
meditating before the Children of men
Be Thou Hadit, my secret center, my
heart & my tongue.
Behold! it is revealed by Anvaras the
minister of Had-pur-kraat
The Khabo is in The Khab, and The Khab in
the Khab
Worship then the Khab, and behold my
light shed over you.

For those not familiar with Crowley's handwriting, the following is a line-by-line guide to that original text, as capitalized and punctuated. The manuscript is the original revelation in the writing of the Beast. Therefore, **read and study the manuscript!** Every typeset version is only an individual interpretation derived from Crowley, and does not carry the authority of the manuscript. It is the charter for the Æon of the Child.

Had! The manifestation of Nuit

The unveiling of the company of heaven
 Every man and every woman is a star
 Every number is infinite: There is no difference
 Help me, o warrior lord of Thebes, in my
 unveiling before the Children of men
 Be Thou Hadit, my secret centre, my
 heart + my tongue.
 Behold! It is revealed by Aiwass the
 minister of Hoor-paar-kraat
 The Khabs is in The Khu, not The Khu in
 the Khabs
 Worship then the Khabs, and behold my
 light shed over you.

Crowley first called it *Liber L*. Later versions and interpretations have been given different names, such as *Liber AL* and *The Book of the Law*. In the present study, the title *Liber L* refers specifically to the manuscript in its original condition.

The scribe was Aleister Crowley. He believed the *warrior lord of Thebes* was Ankh-af-na-Khonsu, identified previously from the Stele of Revealing, and one of his earlier incarnations.

An entity named Aiwass delivered the message orally. Crowley described how he heard the text from over his left shoulder. Aiwass was the spokesman, the Voice from the Silence, the ambassador or *minister of Hoor-paar-kraat*. HPK was his authority. By analogy, it follows the Bible tradition, "And God said:" during the days of Creation.

A brief history explains some problems created by Crowley's publication of *The Book of the Law*, and how they relate the corpus of his other writings and the Æon.

Liber L vel Legis

Θελημα, 1909 —The First Edition

CROWLEY had a typescript of the manuscript made while he was in Cairo. He prepared to publish this typescript in the third volume of his *Collected Works* (1906), but only a proof survives.

The typeset version of this transcription of *Liber L* occurs only in Volume Two of *Θελημα* (1907). The title page is shown below.

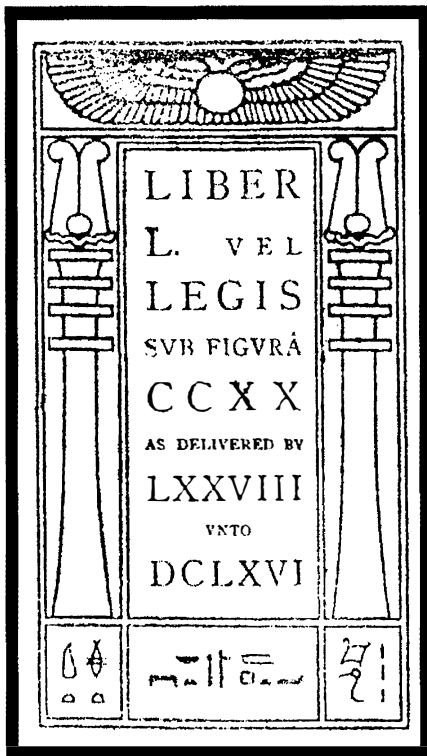

The information relevant to the present study includes:

- 1) The title page introduces “*Figura CCXX*” for the first time. Subsequent typeset versions use this number.
- 2) The 220 verses were determined for the first time.
- 3) The Tzaddi (𐌆) interpretation of the Glyph (𐌆) occurs for the first time.

- 4) This has the original typeset interpretation of the Riddle in Chapter II.
- 5) Other than in text, there is no indication of the Line or Circle Squared of Chapter III.
- 6) It does not include a copy of the manuscript facsimile. It precedes all publications of the manuscript. It does not follow the directions for publication in verse 57 of Chapter III.

The manuscript, *Liber L*, had been misplaced in the UK some time in 1904 or 1905. It was relocated in September 1909 at Boleskine. The original typescript contained many obvious misinterpretations of the manuscript and needed revision.

In the present study, *Liber L* refers to both the manuscript and the publication of the text in *Θελημα* which predated the rediscovery of the manuscript in 1909.

The first publication of a facsimile of the manuscript itself occurred in 1912 in *Equinox* I (7) as a foldout after page 386. The *Old Commentary* followed. This is the first edition published following the internal directions. Regarding the writing of *Liber L*, Crowley later wrote that it was not “automatic writing.” He heard clearly and distinctly the human articulate accents of a man:

To this writing we now turn.

It must have been on the 7th of April that W. commanded P. (now somewhat cowed) to enter the “temple” exactly at 12 o'clock noon on three successive days, and to write down what he should hear, rising exactly at 1 o'clock.

This he did. Immediately on his taking his seat the Voice began its Utterance, and ended exactly at the expiration of the hour.

These are the three chapters of *Liber Legis*, and we have nothing to add to the comment prepared by Fra. P. himself while the Sun was in the sign of the Virgin, Anno V from this revelation.

Note, however, the 65 pages of MS., and the 220 verses.

The reproduction of *Liber Legis* has been done thus minutely in order to prevent the casual reader from wasting his valuable time over it.

The full title of the book is

L I B E R L v e l L E G I S

s v b f i g u r á c c x x

a s d e l i v e r e d b y L X X V I I I t o D C L X V I

and it is the First and Greatest of those Class A publications of A . . . A . . . of which is not to be altered so much as the style of a letter.

W is Crowley's wife, Rose Kelly, Ouarda. P is Perdurabo, Aleister Crowley's name as a Neophyte in the Golden Dawn.

The date of the reception of the manuscript is 8, 9 and 10 April. He heard the message. From Noon to 1PM each day, he received a chapter of *Liber Legis*. *The Book of the Law* is complete in three chapters.

The statement about the verses is questionable. The manuscript does not indicate verses in Chapter One. The three chapters occur on 65 pages of manuscript.

Class A publications are not to be altered so much as the style of a letter. The definition of the Classes of publications is discussed below. If extant, this suggests that any original manuscript supersedes its typescript interpretation. In the case of *Liber L*, for example, there are several variations of S, T, and 4 not expressed in any typeset version. Non-alphabetic or non-numeral characters present particular difficulties.

First Facsimile, Equinox I (7): facing p.386 foldout (1912)

The enlargement below shows Chapter III, page 16, at about double the size that it is reproduced in the foldout — without the grid (see further below).

14

~~some of the letters and their
 units are with: in these respects.
 that the letters shall have: of the
 and each of the: but more than: to
 be, when the: not, which will
 become part of the: the
 the: this: done: in: by: the: the
 circle: of: round: ⊙: in: the: files: in: a
 key: also: and: the: shall: be: if: the: e
 be: the: shall: in: the: by: the: the: the: the
 end: of: the: in: the: the: the: the: the
 hell: from: it.~~

Each page of the original as reproduced in the foldout is approximately 30mm high. If one is familiar with the text, it can be read, but with difficulty. (Its importance was recognized later when it allowed the re-discovered manuscript to be identified with certainty.) The miniature size discourages anyone but a very determined reader. There is no grid on page 16 of Chapter III, and easily identifies its original state. Before then, it could not have been reproduced in facsimile.

The full title is "*Liber L vel Legis as sub figura CCXX and delivered to LXXVIII (78) to DCLXVI (666).*"

Revised Typeset Edition, Equinox I (10): pp.9-33, (1913)

Crowley found the misplaced manuscript in 1909 and accepted its importance. He made several significant corrections and added a commentary. The earliest publication of the edited typeset text of *Liber L* occurs in *Equinox I* (10): 1913. It bears the same title as the manuscript in *Equinox I* (7). At the end, a note refers to the published manuscript in *Equinox I* (7) for doubtful spelling and style.

The Tunis Edition (1926)

This edition is a set of 65 photographs of the pages of the manuscript, in about a 5" × 8" format. The boxed set also included a folded sheet. The pages are easy to read. This fulfills the instruction about the publishing of *Liber L*. The eleven copies include significant changes and comments shown in the title page and in the manuscript.

A L

LIBER LEGIS

THE BOOK OF THE LAW

SUB FIGURA XCC

as defined by

93-799-3-A-418

Author of the Manuscript

the Priest of the Priests

who is

99-757-TOMETHA OHPION

006

How bound plainly after 22 pages of preparation to show pattern.

Area 01 54 to 10 12 45' Area

Less to 7 12 35' Plus

From the Lab of the Lib

The title is now *Liber AL sub figura XXXI*. It records the recognition of the relationship between the number 31 and AL. The more popular name, *The Book of the Law*, is added from the manuscript (II: 38). Aiwass, spelled out in Hebrew and Greek, now has a value of 93 – 418 instead of the original 78. Ankh-af-na-Khonsu, the scribe, identified with To Mega Therion, The Beast 666, Crowley, or *vice versa*.

This is the first use of *Liber XXXI* specifically for the manuscript. In the present study, it will refer only to the manuscript or any of its facsimiles.

The original manuscript has a significant change. The grid on page 16 of Chapter III appears for the first time. It is not original!

The enclosed introductory sheet for *AL The Book of the Law* ends with a concise statement of Crowley's view of its importance:

For, as the experience of these one-and-twenty years has shewn too terribly, the Book cannot be ignored. It has leavened Mankind unaware : and Man must make thereof the bread of life. Its ferment has begun to work upon the grape of Thought : Man must obtain therefrom the Wine of Ecstasy.

Come then, all ye, in the Name of the Lord of the Aeon, the Crowned and Conquering Child, Heru-Ra-Ha : I call ye to partake this Sacrament.

Know — Will — Dare — and be Silent!

The Comment, signed by Ankh-f-n-khonsu, closed the text.

The Equinox of the Gods (1936)

Equinox III (2), The Equinox of the Gods, has the typeset version and facsimile published together for the first time.

The typeset version, as *Liber AL vel Legis sub Figura CCXX as delivered by XCIII = 418 to DCLXVI*, occurs on pages 13-38. The number CCXX is retained. This edition is the basis of all subsequent typeset ones. It is included in Class A.

In the original printing of *The Equinox of the Gods*, the facsimile occurs as 65 full sized individual pages in a separate folder in the back. It is among the best line print facsimiles of the manuscript available. Subsequent printings have the manuscript reduced slightly in size and bound in, and they do not meet the quality of the original printing.

The title on the front of the folder of the original printing is shown below.

A L
(LIBER LEGIS)
THE BOOK OF THE LAW
sub figura xxxi
as delivered by
93 — A I W A S S — 4 I 8
to
Ankh-f-n-khonsu
The Priest of the Princes
who is
6 6 6

Crowley identifies himself (666) as Ankh-f-n-khonsu.

The Comment (later known as the Tunis Comment, Short Comment, or Comment to *The Book of the Law*) is distinct from Crowley's other commentaries on the text of *The Book of the Law*. It is printed on the inside back page of the folder.

THE COMMENT

Do what thou wilt shall be the whole of the Law.

The study of this Book is forbidden. It is wise to destroy this copy after the first reading.

Whosoever disregards this does so at his own risk and peril. These are most dire.

Those who discuss the contents of this Book are to be shunned by all, as centres of penitence.

All questions of the Law are to be decided only by appeal to my writings, each for himself.

There is no law beyond Do what thou wilt.

Love is the law, love under will.

The priest of the princes,

Ankh-f-n-khonsu
—
⌚⌚⌚

If taken literally, its prohibition about study presents a quandry. *Liber XXXI* specifically says one “cometh after him, whence I say not, who shall discover the key of it all (III: 47).” Therefore, study cannot be forbidden, or the statement cannot be fulfilled. The Comment directly violates the text of *Liber XXXI* to which it is a comment.

The sentences, instead, suggest four powers of the Sphinx in a particular way.

- 1) **The study of this book is forbidden** denies knowledge.
- 2) **Whoever disregards this does so at his own risk** denies the expression of will.
- 3) **Discuss...shunned by all as centres of pestilence** limits action (daring). But yeast in a loaf of bread dough is a “center of pestilence”—positive in effect.
- 4) **Questions of Law decided only by appeal to my writings** is silence. “Orthodox” or “official” interpretations are not to be pronounced. Let the words speak for themselves. Note the invitation in *Liber XXXI* II: 2.

How does this help spread the principles of Thelema? The last sentence is the key. It stresses the right and responsibility of each individual to determine its validity for himself by referring back to original writings (? Class A). It is summarized in the final statements “There is no law beyond Do what thou wilt” and “Love is the law, love under will,” which are printed in red.

The Comment is signed by Ankh-f-n-khonsu, the scribe writing the manuscript (Ch. I: page 9, verse 36). The initial A is characteristic of Aleister Crowley’s signature. Since he “shall not in one letter change this book,” The Comment can apply only to the original manuscript of *Liber XXXI*.

Whether The Comment is Class A is debatable. The statements printed in red are. If Crowley had classified it, there would be little debate about the classification. The earliest recorded reference to it as a Class A Comment occurs in Marcelo Motta’s *Commentaries of AL* (1975). The authority of any subsequent person to classify libers, however, is moot. This document might better be called “The Comment to *Liber XXXI* (the original manuscript).” Even so, it also must be evaluated individually.

The Book of the Law (1938)

The edition of 1938, entitled *The Book of the Law, Liber CCXX*, was published in London. The facsimile of the manuscript is absent, *i. e.*, it does not meet the standard of Ch. III: 47. The Tunis Comment occurs after the typeset text.

An edition with the same title was published privately by the O.T.O., and issued by the Church of Thelema in California in 1942. It is a re-issue of the 1938 London edition, but with typographic corrections. It also lacked a facsimile of the manuscript, but contained The Comment. It was the last edition issued during the lifetime of Crowley.

THE BOOK OF THE LAW

[technically called

**LIBER
AL vel
LEGIS**

SUB FIGURA

CCXX

AS DELIVERED BY

XCIII = 418

TO

DCLXVI]

vixi Scripsi in Aries March 21, 1938 e. v.

Privately issued by the O.T.O.
BCM/ANKH
188, High Holborn, London, W.C.1.

Price One Shilling net.

Post-Crowley

Since Crowley's death in 1947, *The Book of the Law* has been published widely, and translated into many languages. Some editions have only the typeset version. Some include the manuscript facsimile. The distinction between the manuscript and typescript is important for study, as will be demonstrated in the analyses in the present book.

Classification of Libers

In *A Syllabus of the Official Instructions of A.'. A.'. Hitherto Published (Equinox I (10): p. 43 (1913)*, Crowley lists the definitions for Classes A through D.

Class "A" consists of books of which may change not so much as the style of a letter: that is, they represent the utterance of an Adept entirely beyond the criticism of even the Visible Head of the Organization.

Class "B" consists of books or essays which are the result of ordinary scholarship, enlightened and earnest.

Class "C" consists of matter which is to be regarded rather as suggestive than anything else.

Class "D" consists of the Official Rituals and Instructions.

Some publications are composite, and pertain to more than one class.

Class A Publications

The above definition derives from the series of statements within *Liber L*. (Note: the manuscript does not designate verse numbers for the first chapter.)

I: page 9 (verse 36):

My scribe Ankh-af-na-khonsu, the
priest of the princes, shall not in one
letter change this book;

I: page 16 (verse 54):

Change not as much as the style
of a letter; for behold! Thou, o prophet
shalt not behold all these mysteries
hidden therein.

II: 54:

...The stops as thou wilt; the letters
change them not in style or value!

III: 47:

This book shall be translated into all
tongues; but always with the original in
the writing of the Beast; for in the
chance shape of the letters and their
position to one another: in these are mysteries
that no Beast shall divine.

The statement in III: 47 is particularly specific about the translation of *Liber XXXI* because it cites the reason for the caveat.

Collectively, these statements guarantee that the original message of Hoor-paar-kraat can be known. By following them, later scholars can separate the original message from later human interpretations—each individual for himself. He may discern the mysteries not revealed to the scribe. Fortunately, Crowley took the dictation conscientiously, and made only minimal (but observable) changes. Unfortunately, neither he nor his successors have always followed the requirement of verse III: 47 that the “original in the writing of the Beast” accompany each published typeset version.

Class A publications include inspired publications. Since few original manuscripts survive, basic research requires use of accepted authoritative texts. Most of these texts are found in *Equinox I*, especially in volume 7. *The Holy Books of Thelema, Equinox III (9)*, is a critical, single-volume compendium. It omits *Liber 418, The Vision and the Voice*, and the note to *Liber 963, The Treasure-House of Images*.

“The chance shape of the letters and their position to one another are mysteries that no Beast shall divine” is honored in the present study as strictly as possible. The principle is applied to all Class A material.

The Class A publications are the primary exposition of principles of the Æon. In essence, they expand on the content of *Liber XXXI* in poetic or systematic form. They expand knowledge, describe initiation, and provide material for understanding the mysteries of the Æon. The symbolism among the Class A libers is consistent. The present book demonstrates the inter-relationship among the symbols used among a few of the Class A publications.

Even the organization of the *libers* gives clues to the symbolism in their contents, as follows:

- 3 – Creation formula $0 = 1 = 2$
Liber XXXI or L vel Legis (3 chapters, 65 pages)
Liber CDXVIII vel Vision and the Voice (30 Æthyrs), Voice of Angel
- 5 – Alchemical elements
Liber LXV vel Cordis Cincti Serpente (5 chapters of 65 verses)
- 7 – Planets
Liber VII vel Lapidis Lazuli (7 chapters)
- 10 – Sephiroth on the Tree of Life
Liber XXVII vel Trigrammaton. (10 sephiroth, 27 trigrams)
Liber DCCCXIII vel Ararita. (10 sephiroth + additions)
- 22 – Hebrew alphabet or Paths on the Tree of Life
Liber I vel Magus (22 verses)
Liber X vel Porta Lucis (22 verses)
Liber LXVI vel Stellæ Rubeæ (66 verses)
Liber CLVI vel Vallum Abiegnus (66 verses)
Liber CCXXXI vel Arcanum ton Atu twn Tahuti (22 Hebrew letters)
- 39 – Unity in triune form — 13×3
Liber A'ash vel Capricorni Pneumatici sub figura CCCLXX (39 verses)

These patterns of organization occur in *libers* outside Class A. They suggest approaches to their analysis. Some specifically relate to the Mystery of the Letters. With *Liber XXXI*, they form the basis for the present study.

Liber XXVII vel Trigrammaton

LIBER TRIGRAMMATON, being a book of Trigrams of the Mutations of the TAO with the YIN and YANG.

An account of the cosmic process: corresponding to the *Stanzas of Dzyan* in another system (Crowley, 1913).

VEL TRIGRAMMATON

It describes the Course of Creation under the Figure of the Interplay of Three Principles. The book corresponding to the *Stanzas of Dzyan* (Crowley, 1919).

The full knowledge of the interpretation of this book is concealed from all.

The Practicus must nevertheless acquire a copy, thoroughly acquaint himself with the contents, and commit them to memory.

XXVII

The number of permutations of 3 things taken 3 at a time, and (of course) the cube of 3 (Crowley, 1913).

Aleister Crowley received *Liber XXVII vel Trigrammaton* on the evening of December 14, 1907. In the Official Instructions of the A.°. A.°, he says: *Liber XXVII* is given to the Practicus, as “in this book is the ultimate foundation of the highest theoretical qabalah.” A handwritten copy of *Liber XXVII* apparently occurred in one of Crowley’s vellum notebooks now at the Warburg Institute in London. The index page of the volume lists *Liber Trigrammaton*, but the relevant pages have been excised. No copy of this liber in Crowley’s hand is reported to survive. Printed editions, beginning with *Θελημα* Volume 3 (1909) have a consistent pattern and sequence for the trigrams and text.

Trigrammaton is one liber where the typeset version has reasonable assurance of communicating subtle details of the original. The trigrams are simple. The printed text is probably close to an accurate rendition of a handwritten received manuscript. Only typeset variations in punctuation occur among published editions. The text version in *The Holy Books of Θελημα* (1983) is used here.

Trigrammaton is a book of the mutation of the Tao (•) with the Yang (–) and the Yin (–). It includes, and expands on, the trigrams of the classic *I Ching*, one of Crowley’s most frequent forms of divination. The trigrams describe creation as the interplay of Three Principles. The book corresponds to the *Stanzas of Dzyan* (Blavatsky, 1888) in another system (though it is not followed here, for reasons explained later).

Crowley relates the three principles or forces to Nuit, Hadit and Ra-Hoor-Khuit. They relate to a passive (female, –) principle, an active (male, –) principle, and the union of the two (origin or equilibrium, •). They

correlate to the pillars on the Tree of Life (TL). They occur as parallel helices on the three-dimensional Quantum Tree (QT) model presented below.

Trigrammaton provides details about the units in the Cube of Three. The associated text describes the lights and vessels of sephiroth on the Tree of Life. The arrangement of sephiroth, a new Tree of Life model, the Quantum Tree (QT), is presented as three-dimensional. The later chapter shows the correlation between the Cube of Space, the traditional Tree of Life (TL) and the Quantum Tree (QT).

Liber CCXXXI — Atus of Tahuti

The title of this liber is long and complex. It is a mixture of Greek and Latin, with few familiar words. As with *Trigrammaton*, its complexity tends to deter magicians from detailed study. One Thelemite told me that it was just Crowley's joke. To which my response was only, "Class A?" The full title is:

Liber Arcanorum twm Atu tou Tahuti Quad Vidit Asar in Amennti Sub Figura CCXXXI Liber Carcerorum twm Qliphoth cum sui Geniis. Adduntur Sigilla et Nomina Eorum.

Translated, its composite nature is clear.

The book of the secrets of the Atus of Tahuti, which
Asar saw in Amennti (the underworld).

Under Figure 231

The Cells of the Qliphoth with their Genii.

To which are added the sigils and their names.

The Synopsis in *The Holy Books of Thelema* (1975) includes several quotations from Crowley about this liber:

This is an account of the cosmic process so far as
it is indicated by the Tarot Trumps.

Liber CCXXXI is a technical treatise on the Tarot.
The sequence of the 22 Trumps is explained as a
formula of initiation.

Liber CCXXXI Sum of the numbers [0 + 1 + . . .
 . . + 20 + 21] printed on the Tarot Trumps.

The title specifically relates to the Atus of Tahuti. These Tarot trumps relate directly to the paths on the occult Tree of Life. Eliphas Lévi (1856) recognized the occult nature of the Tarot. He related it to the Hebrew alphabet and a well-developed system of symbolism that goes back to at least to the *Sepher Yetzirah* and *Zohar*.

The only surviving part of the original manuscript of this liber is one sheet at the University of London Senate House Library. It has pencil sketches by Crowley. The overlaid ink tracings could be either by Crowley as directions for J. F. C. Fuller, or by Fuller himself. Only *Domus Mercurii* sigils are included. The penciled Hebrew letter attributions are from Crowley.

The sheet is significant because it shows the sigils as a composite arrangement. The sigils now attributed to Heh and Vau are not in the Hebrew letter order of the rest.

The pencil marks at these sigils suggest that Crowley later recognized this. He noted the error in the penciled Hebrew letters where a light Heh is under the darker Vau.

Crowley apparently gives notes to Fuller in three sections of pencil notes in the left-hand margin, as follows:

General Design.

May be a wheel with 22 components on the rim.

The wheel has 8 spokes. At the corners are the Cherubim.

But the Pillar Scheme is equally good.

Note the change of ך and ך.



These sigils are dangerously automatic
 and should never be exposed or
 left lying about $ov \mu\eta 7^{\circ} = 4^{\circ}$.

This is perhaps because they are the atus which Asar beheld in Ammennti (sic). They are therefore the governors inspectors of the disordered fabrications.

Several authors have written about the qliphothic sigils. Rarely has the verbal text been analyzed. The names of the genii are more often quoted, but without indication of their meaning. The list of genii also provide clues to the Hebrew/English alphabet equivalents.

The present study integrates each part of the 22 paths. The proposed QT has 32 paths without counting the Sephiroth. There are no QT path data for the Glyph, the second path of Samech, or the paths from Da'ath.

Liber CDXVIII — Liber XXX Ærum vel Sæculi (Thirty Æthyrs or Spirits of the Age)

The Vision and the Voice, is technically entitled *Liber XXX Ærum vel Sæculi*. The Official Instructions of A.'. A.'. in *Equinox I* (10): pp.43-56 put it in Class A – B. The instruction says:

Besides being the classical account of the thirty Æthyrs and a model of all visions, the cries of the Angels should be regarded as accurate, and the doctrine of the function of the Great White Brotherhood understood as the foundations of the Aspiration of the Adept. The account of the master of the Temple should in particular be taken as authentic.

This includes those portions spoken by the Angel as Class A. The rest is Class B, except the ritual in the 8th Æthyrs in Class D.

Many Thelemites consider this liber second only to *Liber XXXI* in importance. The original manuscript in Victor Neuberg's hand is extant. In that working, he recorded the voice of Crowley, as seer.

Class B**Liber 777**

Crowley published only one edition of *Liber 777* in his lifetime. The *Official Instructions* list it under Class B, as a “tentative table of correspondences between various religious symbols.” It follows much of the data assembled in the Golden Dawn. As Class B, it is subject to scholarly amendment. The title page is shown below.

777

VEL

PROLEGOMENA SYMBOLICA AD SYSTEMAM
SCEPTICO-MYSTICAE VIAE EXPLICANDAE,
FUNDAMENTUM HIEROGLYPHICUM SANC-
TISSIMORUM SCIENTIAE SUMMAE

אחת רוח אלהים חיים

PRICE TEN SHILLINGS

London and Felling-on-Tyne
THE WALTER SCOT PUBLISHING CO., LTD.
1909

[All rights reserved]

The frontispiece showing the Tree of Life and a short introduction citing sources precede the Table of Correspondences and Notes.

THE TREE OF LIFE

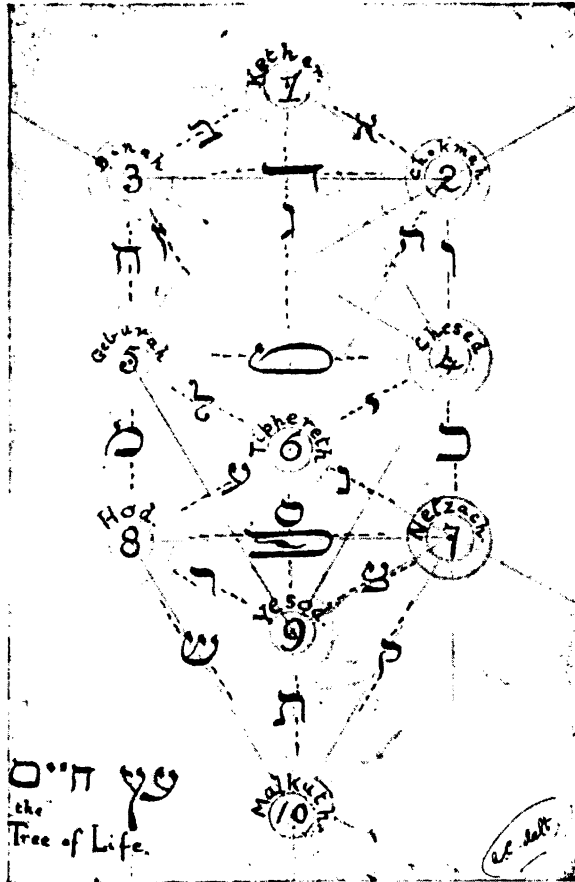

COL. XII. This arrangement is the basis of the whole system of this book. Besides the 10 numbers and the 22 letters, it is divisible into 3 columns, 4 planes, 7 planes, 7 palaces, etc., etc.

Liber 777 is an index for comparing symbols in different occult and religious systems. The columns use lines identified by a Key Scale Number. They correlate many symbols to the Hebrew alphabet, the sephiroth and the paths on the Tree of Life.

0 refers to the Ain, Ain Soph and Ain Soph Aur

1 to 10 refer to the Sephiroth on the TL — Kether to Malkuth

11 to 32 (plus 31 bis and 32 bis) refer to letters of the Hebrew alphabet.

The Hebrew alphabet is in traditional order, Aleph to Tau. The zodiac signs are in their order in the heavens, Aries to Pisces. The Tarot trump (column XIV) are in the Golden Dawn Practicus lecture—in order with The Emperor (V, ♀) Strength (VIII, ♂), Justice (XI, ♁) and the Star (XVII, ♃). The remaining trump agree in both the Marseilles sequence and the Thoth Tarot deck

Neptune Press published a revised edition, as “*A reprint of 777 with much additional matter by the Late Aleister Crowley*” in 1955. In 1973, Samuel Weiser in New York published a further enlarged edition under the title *The Qabalah of Aleister Crowley*. It included *Gematria, Liber 777 and Sepher Sephiroth*. Subsequent printed editions have the title, *777 and other Qabalistic Writings of Aleister Crowley*.

In 1980, the O.T.O. in California published a facsimile of Jack Parson’s copy of the 1909 edition, with his notes added in ink.

Liber LXXVIII – A Description of the Cards of the Tarot

The Tarot trumps, their significance and sequence are among the most discussed mysteries of occultism. Originally, they were used just in a card game. The cards then were used for divination. Eliphas Lévi (1856) recognized their occult significance. In the late 19th Century, the Golden Dawn incorporated the Tarot into its comprehensive symbol system. Regardie (1940) finally published the material in his treatise *The Golden Dawn*.

Crowley (1912) had already published the material from the Golden Dawn as *Liber LXXVIII*, “A Description of the Cards of the Tarot,” in *Equinox* I (8). It records Crowley’s understanding of Tarot symbolism at the time of the reception of Class A material.

The Book of Thoth

Near the end of his life, Crowley published *The Book of Thoth* (1944). This work is probably his most comprehensive synthesis of the symbol system for the Æon of the Child. It expands on the Thoth Tarot deck that he developed with Frieda Harris. The text gives insight into the meaning of the symbols. The book is cited as Class B, but without a number, in the appendix of *Equinox* III (9). It fits that definition, though the original publication gives no such citation.

During his lifetime, Crowley wrestled with the interpretation of the Glyph in the first chapter of *Liber XXXI* and its place among the Tarot trumps. He first interpreted it as a Tzaddi in the unpublished proof of the *Collected Works, Volume III* (1907). He defended his interpretation of the Glyph as a Tzaddi in the *Extenuation of the Book of the Law* (1926, unpublished manuscript). His explanation in *The Book of Thoth* involved both the switch of Teth/Lamed (that he was aware of from his Golden Dawn training) and the Heh/Tzaddi switch (his interpretation derived from the statement in *Liber XXXI*).

Crowley's interpretation has presented difficulty to many Thelemites and other occultists. Sometimes, the controversy seems to outweigh the significance and meaning of the cards. For the present study, data relating to the sequence of the Tarot trump, tied to the Hebrew alphabet and the occult significance, are salient.

The Mysteries

The focus of the present study is based on the three-dimensional Tree of Life (Quantum Tree: QT) model through which the Mystery of the Letters is decoded. The analysis evolves from the original Tree of Life in 777 as understood by Crowley. The interpretation of the Class A and Class B material, described above, strives for a consistency of symbolic meaning. Class A material takes precedence over Class B.

Liber XXVII vel Trigrammaton revealed a three-dimensional QT arrangement of the sephiroth. Generally, it is congruent with the traditional Tree of Life (TL).

Liber XXXI clarifies information about the paths on the QT. This model reveals additional paths. These are not recorded in Class A libers or *Liber 777*. The 32 Paths of Wisdom of the *Sepher Yetzirah* are interpreted differently. The analysis also reveals interrelationships among the Hebrew, Greek and English alphabets. The Riddle in Chapter II: 76 is a listing of the paths on the QT.

Liber CCXXXI further expands information about the paths, with emphasis on the Tarot and duality.

Liber LXXVIII and *The Book of Thoth* add additional information about the occult Tarot. The former expresses Crowley's early concept. The latter one expresses his final one.

Liber 777 treats the old Hebrew letters and their associated TL paths. Additional paths recognized on the QT are not included. Nor are the final letterforms included. Their understanding will need further research and revelation.

The symbol system of the Æon of the Child is a way of transmitting the message of Hoor-Paaar-Kraat. The inter-relationships among the approaches strengthen communication, knowledge and understanding. To accomplish this goal, the system must be consistent, rational, and intuitive. Anything else would create even more misunderstanding and illusion.

CHAPTER II — MESSAGES AND MODELS

Messages

FOR every message, there must be an origin, a messenger, a vehicle, and a recipient. For printed material, these are the idea, the words, the printed page and the reader. For art and symbols, there are the artist, the design, the medium, and the observer. For a computer, there are the data input (bytes), the application/platform, the electronic transmission, and the output. For radio and television, there are the scripts, the performance, the recording the broadcast, and the audience. Communication is not complete until a recipient has perceived it. The transmission of data may lead to knowledge, understanding and wisdom, as perceived by man.

Interrelating messages from different dimensions is a daunting problem. Data distortion occurs when moved from one system, set of dimensions or medium to another. Some data become more apparent, others become more obscure or irrelevant. Prior conceptions are often hard to discard, especially when change is sudden.

When data is processed systematically, results can be compared. They may be congruent, though they appear to be different.

The Æon of the Child is a system that opened just after the beginning of the 20th Century. It views the Universe in a distinct, and revolutionary way. The message sequence is:

The Message	<i>The Book of the Law</i>	Hoor-Paar-Kraat, Authority
The Messengers	Aiwass Ankh-f-n-Khonsu, Crowley	Revealer, Minister of HPK The Scribe/Prophet
The System	The Æon of the Child	Ra-Hoor-Khuit, Initiator
The Audience	Mankind	Everyone, Thelemites

Models

One-dimensional (1-d) Models

Alphabets and Numbers

Every alphabet is an ordered series of letters. Every electronic message is a linear sequence of bytes. They are one-dimensional (1-d). With systematic transformation using an appropriate system, they can describe additional dimensions. Alphabets, numbers and bytes are the most basic symbol systems. They combine to form words and sentences, formulas, and lines of code. In so doing, they create virtual multidimensional results.

The *Sepher Yetzirah*, *The Book of the Law*, and *Liber Trigrammaton* are occult texts expressed in 1-d. *Liber 231, The Atus of Tahuti*, has a 1-d text with 2-d diagrams. They each contribute to a composite Tree of Life model.

Sepher Yetzirah

The *Sepher Yetzirah* is a foundation for a 2-d Tree of Life (TL) and Hebrew qabalah. It deals with the principles of the creation of the world and the way it exists, *i.e.*, cosmogony and cosmology (Townley, 1993). Its significance still contributes to western occultism.

The *Sepher Yetzirah* describes the fundamental principles of creation in thirty-two paths, traditionally defined as 10 sephiroth plus 22 letters. It contains secrets believed revealed to Abraham. Kaplan (1990) provides several text variations and an extensive interpretation. He includes descriptions of the Tree of Life and the Cube of Space.

The *Sepher Yetzirah* I: 1 ends with: בשלשה ספרים וספר וספור or with three books, with text, with number and with communication. The word ספר literally means book, or text. The word ספר means cipher, and סיפור communication means telling, implying vocal sound. When God “said,” sound was involved. In a sense, we see the letters, the numbers and the sounds as the basis for the book or creation. This is the original Mystery of the Letters.

Liber Trigrammaton

The trigrams of *Liber Trigrammaton* are in a linear sequence, therefore 1-d. Each trigram has three lines that have a Tao (•), Yang (–) or Yin (–) symbol.

The combination of three lines taken three at a time and filled by one of three of these symbols makes 27 possible combinations. These can be arranged into a 3-d Cube of Space. Each of the 27 trigrams has a text that implies a sephira on the Tree of Life. As such, it also indicates a multi-dimensional aspect. Their interpretation forms the basis of the next chapter.

Stanzas of Dzyan

Crowley discusses *Trigrammaton* and the *Stanzas of Dzyan* as related systems. Like *Trigrammaton*, the *Stanzas* are linear. Three points become immediately obvious:

- 1) It is a proposed description of evolution.
- 2) *Cosmogogenesis* has seven verses.
- 3) *Anthropogenesis* has twelve.

The description matches *Trigrammaton* in the broad sense, although it utilizes Greek mythology. In *Cosmogogenesis*, the numbers match the first two series of *Trigrammaton*. *Anthropogenesis* has 12 stanzas that agree in number with the 12 trigrams of the Third Series of *Trigrammaton*. An examination of the Stanzas indicates some further correspondence.

The *Stanzas of Dzyan* were published by the Theosophical Society (Blavatsky, 1888) in *The Secret Doctrine*—a very extensive and complex commentary of the original stanzas about esoteric evolution. Maroney (2000) provides the original stanzas and selected commentary from the original as well as background and other material.

In a specific reference to Crowley, Maroney mentions his commentary to *The Voice of the Silence*, and Crowley's own cosmological work, *Liber Trigrammaton*. He continued:

So far, there is little scholarship that traces Blavatsky's influence on Crowley, which is much greater than generally

realized. Much of it takes the form of references to symbolism prominent in Blavatsky, such as the point in the circle, the identification of the nature of people as stars, and the “Day of Be-With-Us.”

Maroney continues:

As regards the evolution of mankind, the Secret Doctrine postulates three new propositions, which stand in direct antagonism to modern science as well as to current religious dogmas: it teaches (a) the simultaneous evolution of seven human groups on seven different portions of our globe; (b) the birth of the astral before the physical body, the former being a model for the latter, and (c) that man, in this Round, preceded every mammalian—the anthropoids included—in the animal kingdom.

The footnote to this paragraph cites evidence in *Genesis* I: 7 and II: 19. It includes a more detailed explanation relating to the different creations. *Cosmogenesis* describes how the universe is formed by differentiations from a primordial unity. While a time scale is relative, the geological sequence is not.

Crowley accepted ideas from Blavatsky. He included *Liber LXXI: The Voice in the Silence / The Two Paths / The Seven Portals* in Class B. He refers it specifically to *Trigrammaton*. There is definite conflict between it and the current understanding of science. Its premises have been discredited by modern science, so it is not included further in the present study.

Two-dimensional (2-d) Models

Tree of Life

The Tree of Life model is a basic and historic arrangement of the Universe. The earliest examples occur in the Middle Ages. When the text of the *Sepher Yetzirah* was translated into TL models, several interpretations of the arrangement arose. The TL model had no standard. Several interpretations and additions to the sequence of the sephiroth exist. Even the identity of the sephiroth was equivocal, as was the arrangement of the paths.

The Hebrew Tree of Life (TL) is two-dimensional. It derives from the *Sepher Yetzirah*. Kaplan (1990) shows the arrangements of sephiroth according to Ari (Isaac Luria (1534-1572) and Gra (Elijah ben Schlomo Zalman, 1721-1797). Hebrew qabalah attributes three mother letters to horizontal paths, the seven double letters to vertical paths, and the 12 single letters to diagonal paths.



J, Gikatilla 1516. *Portae Lucis*. Augsburg

An early illustration of the TL appears in *Portae Lucis* (1516) by Joseph ben Abraham Gikatilla (1248-ca.1305). The Gra tree in Kaplan is similar in the arrangement of sephiroth, but the paths are labeled differently. The sephiroth in the later Ari version are closer to the modern TL arrangement, but the path arrangement is different.

These two classic Hebrew qabalists show different interpretations of the TL. The two patterns are similar to the two phases of the 3-d Quantum Tree, discussed below.

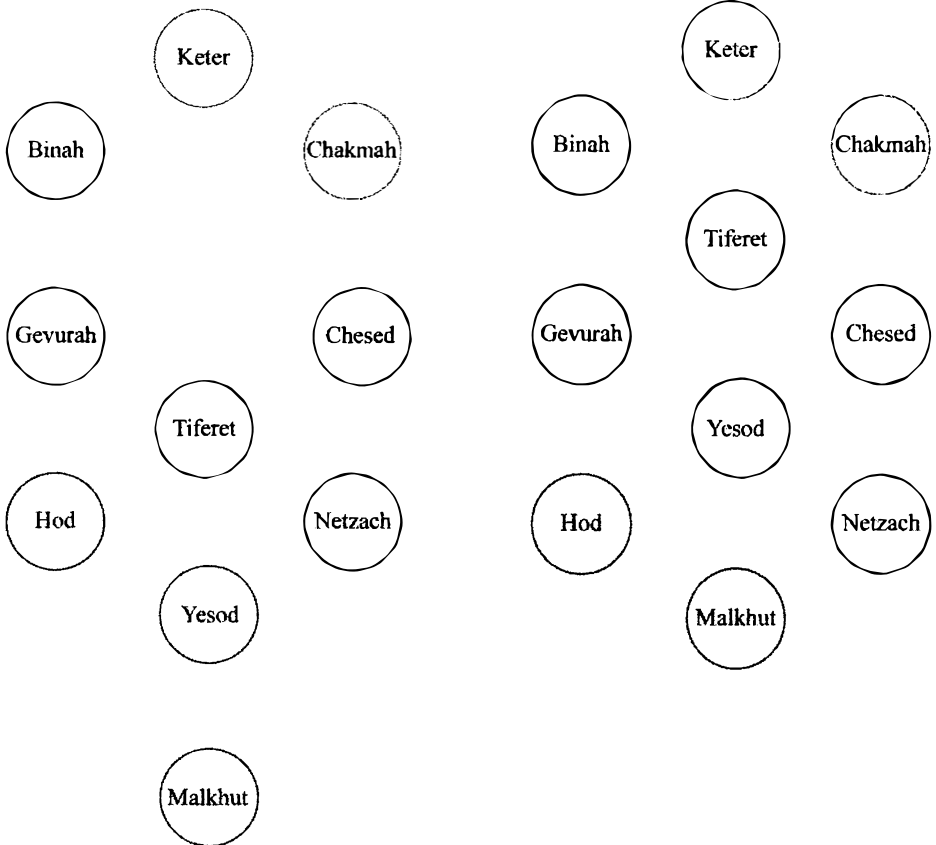

Sephiroth Arrangement — after Ari

Sephiroth Arrangement — after Gra

As a 2-d diagram, the TL has left and right; front and back; averse, inverse and reverse. However, unidentified is the frame of reference, its analogous earthly orientation and the viewpoint of the observer. Additional 2-d models have superimposed the Lightning Flash and Adam Kadmon.

Kircher's (1652) Tree of Life and the Golden Dawn Tree of Life (Kuntz, 1996) are similar to the Ari Tree. This is the base model used in the Western Occult tradition.

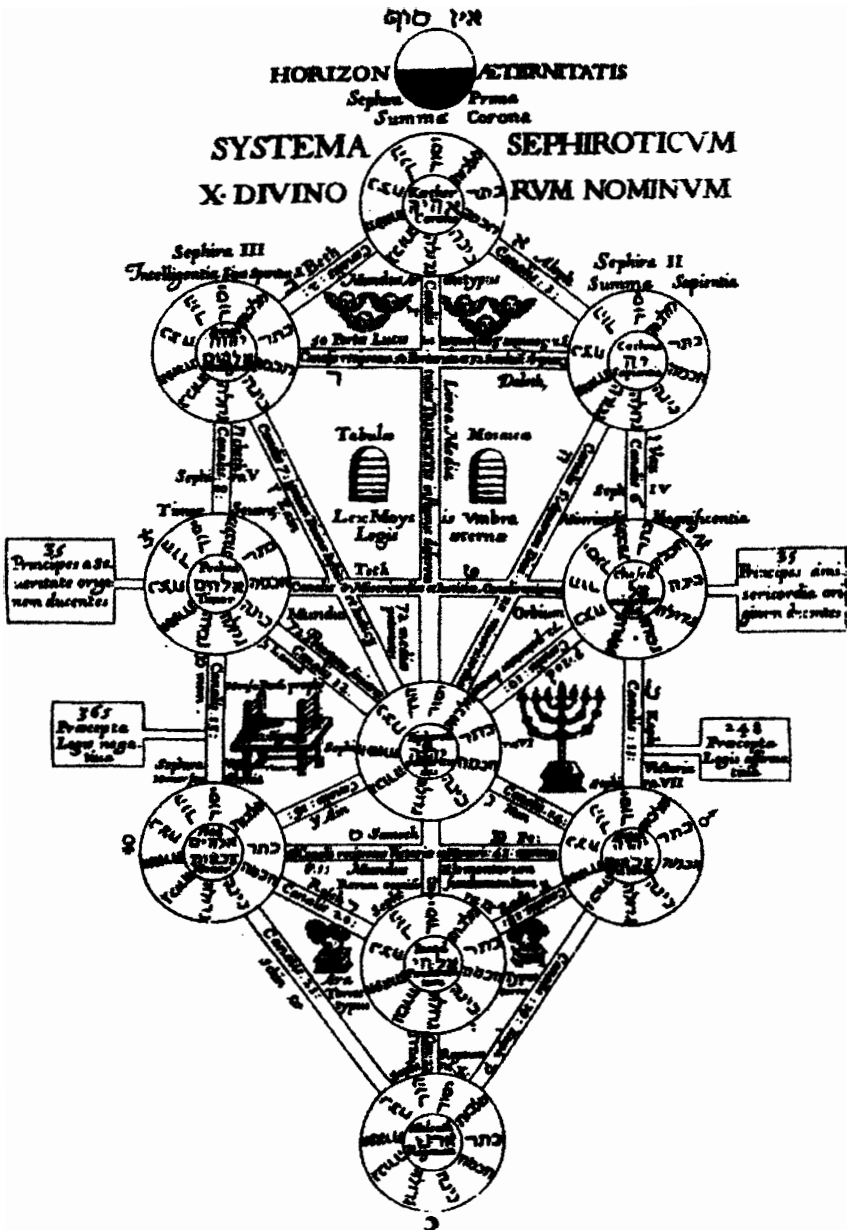

Three-dimensional (3-d) Models

Man perceives the world and the Universe in 3-d. In measuring an item, it is length, width and height (the X, Y and Z axes of mathematics). On earth, it is longitude, latitude and altitude. In space, it is longitude, latitude and light years. The last is a measure of separation from man, with the illusion that man is always at the center of the Universe. The least distorted models appear to be 3-d — but any model is only an illusion of reality. The map is not the territory.

I Ching

The I Ching, a classic system, uses two trigrams (a hexagram) to depict the Universe. The Chinese used it for divination, as Crowley did regularly.

The trigrams contained only Yang (—) and Yin (--) lines. For interpretation, any (or all) of the lines were mutable to the opposite type, so a related second hexagram added to the complexity. These trigrams are identical to the Fourth Series of trigrams in *Liber Trigrammaton*.

The sequence of the hexagrams is linear (1-d). The component trigrams can be separated separately and put on the X and Y axes of a chart. This produces the 2-d model used as an index.

Using each of the lines of a trigram as a dimension, (X, Y and Z), a 3-d Cube of Two can be constructed. Each Cube can be arranged similarly as a unit within a larger Cube of Two with the same dimensions. The result is a Cube of Four.

The Cube of Four arrangement distributes the 64 possible hexagrams in four dimensions. One Cube of Two (a set of trigrams) represents 3-d Space. Its position in the larger Cube of Two represents Time. It does not matter whether the upper or lower trigram is considered first. This fits well with Einstein's Theory of Relativity, contemporary with *The Book of the Law*.

Cube of Space

The Cube of Space concept goes back at least to the *Sepher Yetzirah*. Its dimensions extend from an origin at the center of the cube. Each dimension has direction, positive or negative, away from the center.

The Hebrew qabalistic view attributes the three axes to the mother letters. The six faces of the cube, plus the origin, are the seven double letters. The 12 edges of the cube attribute to the single letters. Their occult attributions relate to the elements, the planets and the zodiac, respectively.

Townley (1993) elaborates five pairs of opposites (\approx dimensions). The *sephiroth of belimah* implies the ten have no end: beginning and end, good and evil, height and depth of the abyss, depth of east and west, depth of north and south. God rules over all from His holy abode. He adds, from these dimensions the three dimensions of space (length, width, height = North/South, East/West, Above/Below), plus Time (beginning/end). They define physical reality. The fifth dimension (which has not yet been discovered by physics), is the ethical one—good/evil, according to the *Sepher Yetzirah*. Each dimension has two contrasting ends or directions, which may later be related to the front and back of the TL, or positive and negative existence.

The present study changes the perspective, based on the patterns in *Trigrammaton*. Instead of describing the Cube from the center, it describes it from an apex. The defense is presented in the next chapter. A series of nested cubes becomes the Cube of One at an apex of the Cube of Two, and the Cube of Two at the same apex of a Cube of Three. The Cube of One is Malkuth. The Cube of Two reaches from Malkuth to Da'ath. The Cube of Three reaches from Malkuth to Kether.

A central linear core contains the three homogeneous trigrams—Kether (☰), Da'ath (☷) and Malkuth (☱). The original design had the sephiroth arranged in pillars, as in the 2-d TL. This arrangement makes it easier to compare the QT in a static situation to the TL. However, it does not show how certain paths vary in their occurrence.

The helical interpretation resulted from the building a solid model. The erect form was unstable. The principle of dense packing caused the sephiroth spheres to move into a stable helical form. Its form parallels the Double Helix model of the DNA molecule (Watson and Crick, 1953). Photographs of the model constructed using information in *Trigrammaton*, are shown separately as color illustrations.

The trigrams form four series, each defined by the number of Tao (•) elements—3, 2, 1, and 0. The odd numbered ones represent the lights (Kether and Sephiroth). The even ones represent the vessels of Briah (2 Taos) and Da'ath, Yetzirah and Assiah (no Taos).

Liber Trigrammaton has a built-in statement that suggests an extension into a Cube of Four. The first trigram (☰) says:

Here is Nothing under its three forms.
It is not, yet informeth all things.

If this trigram is *Nothing under three forms*, there must be Nothing without those three forms. Kether 111 (☰), Da'ath 222 (☷) and Malkuth 333 (☷☷) have homogeneous trigrams. The extension of that diagonal of the cube would be trigram 000 (☸), Ain.

Three axes of three radiate from Ain. They represent the Ain Soph, the influence of which defines a Cube of Three. The remaining 27 are the negative analogs of *Trigrammaton*. They are the Ain Soph Aur, which equals the Qliphoth. As with the trigrams in the hexagrams of the *I Ching*, the two existences are relative to one another, so Positive and Negative Existence are interchangeable. One cannot be recognized without the other.

As with the Cube of Space and the Biological Code, the Cube of Four culminates the series. The Quantum Tree has a mirror image or complement. The Ain Soph defines both. The total number of units in each of the models is 64, the cube of $4 \times 4 \times 4$.

However, the present study is limited to the Cube of Three, from Atziluth to Assiah. A further expansion awaits—call it *Tetragrammaton*. In *The Book of Thoth*, Crowley describes the Universe as the expansion of the number Four. A glimpse of this was seen in the *I Ching*, above. On some 2-d TL (*a la* Golden Dawn) above Kether are the Veils of Negative Existence. They appear in *Liber 777* in line 0. These veils are included in the Cube of Four.

Most trigrams have capitalized words in their associated text. These are taken as clues to the character of the trigram and clues to attributed sephiroth. When there are no capitalized words, the sentence subject is considered the most likely key word of the text.

Quantum Tree — QT

The Quantum Tree proposed here is a dynamic model derived from the verses in *Liber Trigrammaton*. The QT model respects both the structure of the trigrams and their sequence. Diagrams of the erect and helical forms are

shown in the color illustrations. The sephiroth are indicated by the traditional Golden Dawn colors. They form the terminals of the paths on the Tree of Life. A unique pair of sephiroth determines each path. All possibilities must be explained according to the analogy of probability in quantum behavior. The following chapters show the possibilities for the sephiroth and the paths for the Quantum Tree model.

The first clue to alternative phases came from the quotation in trigram for the Brothers of the Left-hand Path, trigram 132 (☵☶). It points out a relationship to the Black Brothers, trigram 321 (☶☵). This suggested two possibilities, with the alternatives occurring simultaneously. This is an analog to quantum shift in physics, or resonance.

In the chapter on *The Book of the Law*, the style presentation shows the sephiroth as if they were printed on the surface of a cylinder, and then flattened and spread.

CHAPTER THREE — LIBER XXVII VEL TRIGRAMMATON

LIBER TRIGRAMMATON is a book of the mutation of the Tao (•) with the Yang (–) and the Yin (--). It includes, and expands on, the trigrams of the classic *I Ching*, one of Crowley's most frequent forms of divination. The trigrams describe creation as the interplay of Three Principles. They are the permutations of three things, taken three at a time. It is the Cube of Three, or the Cube of Space.

Two conjoined trigrams form a hexagram in the *I Ching*. In their introduction to *The Original I Ching Oracle*, Ritsema and Sabbadini (2005) wrote:

The hexagrams of the Yi Jing are based on a binary code whose elementary units are the opened line (--) and the whole line (–). The opened line is *supple* and is associated with Yin, the whole line is *solid* and is associated with Yang. Yin and Yang are the fundamental categories of Chinese cosmology, the primary duality arising from the original One.

Dao begets One.
One begets two.
Two begets three.
And three begets the myriad beings.

(Quoted from Lao Zi, chapter 42)

The quotation implies that the zero may represent the Dao, and is before One.

Trigrammaton presents two congruent models simultaneously. Crowley recognized the trigrams in the Cube of $3 \times 3 \times 3$. He did not explore the 3-d relationship between the verses and the sephiroth of the Tree of Life. Both models are three-dimensional. His concept of the Tree of Life was 2-d.

The tri-radiate nature shows in the three edges radiating from an apex. It requires little explanation. A distinct diagonal of the cube also connects to the opposite apex through the center of the cube. It is congruent with the Central Axis on the QT, below.

Several authors have proposed 3-d models of the Tree of Life (Achad, 1974; Regardie, 1971; Wang, 1983), but none is convincing. A new 3-d Quantum Tree (QT) model is proposed here. The construction of a hard model has satisfied the parameters—pillars, triads, sephiroth. They are comparable to those on the 2-d Tree of Life (TL) model.

Crowley relates the three principles or forces to Nuit, Hadit and Ra-Hoor-Khuit. They relate to a passive (female, --) principle, an active (male, -) principle, and the union of the two (origin or equilibrium, •). Two principles are the same as in the *I Ching*.

Qabalistically, each trigram can be converted to a number. In the *I Ching*, the Yang (--) uses the number two (2), and Yin (-) uses the number three (3). In *Trigrammaton*, number one (1) becomes the Tao (•). Each trigram then follows in a numerical sequence, reading from top to bottom. Numbers make the order of the trigrams easier to remember.

A sephira is the combination of a vessel filled (in-formed) with light. In their position to one another, the trigrams form an index to the sequence of verses. The text follows the sequence of sephiroth on the TL or QT.

The trigrams of *Trigrammaton* are a linear arrangement of lights and vessels defining the sephiroth on the QT. There must be ten sephiroth, not nine, not eleven, as established in the *Sepher Yetzirah* I: 4 (Kaplan, 1990).

Hebrew qabalah has two emanations of existence. In the First Emanation, Godhead created (and became separate) from the Universe. Light flowed toward the Universe. This ultimately caused a breakdown, called the Breaking of Vessels, Shevirah (שבירה). The broken shards reformed as vessels of the sephiroth. Light from the Godhead filled them. Therefore, **a sephira is a vessel filled with light**. The name of the first, Kether, comes from *Exodus* 31: 3. Chokmah, Binah and Da'ath are found associated in *Exodus* 35: 31. From Chesed to Malkuth, the names come from *1st Chronicles* 29: 11. See also *Proverbs* 3: 13 to 20. According to *The Wisdom of the Zohar* (Lachower & Tishby, 1989), the identification of individual sephiroth varies.

The hypothesis here posits *Liber Trigrammaton* as a systematic description of a Cube of Space model using trigrams. The diagonal of a cube is its longest dimension. It goes from one apex through the center of the cube to the opposite apex. This is congruent with the Central Axis of the QT. The three edges from one apex of the cube are analogues to the pillars on TL, or helices on the QT. The trigrams for the lights and the vessels follow the sephiroth in sequence. There are 27 trigrams, but only 10 sephiroth. This is resolved in the model.

THE CUBE OF SPACE

Townley (1993) presents an analysis of the Cube of Space based on the *Sepher Yetzirah*. His cube orients from the center, with three perpendicular axes extending from it, and twelve edges. They are the origin, six directions (from three mother letters extending outward from the origin, and the 12 signs of the zodiac. These readily match the first three series with Tao elements (1, 6 and 12) of *Liber Trigrammaton*. Later he used a solid presentation, but still oriented from the center.

The difficulty with any three-dimensional model presented on a plane surface (2-d) is that something must be omitted or distorted. Any isometric view of a cube will leave one corner and its adjacent surfaces hidden. By separating the units into layers, the arrangement converts the component cubes into three separate planes. In either case, when the distortion or sampling is systematic, the whole can be reconstructed from its parts.

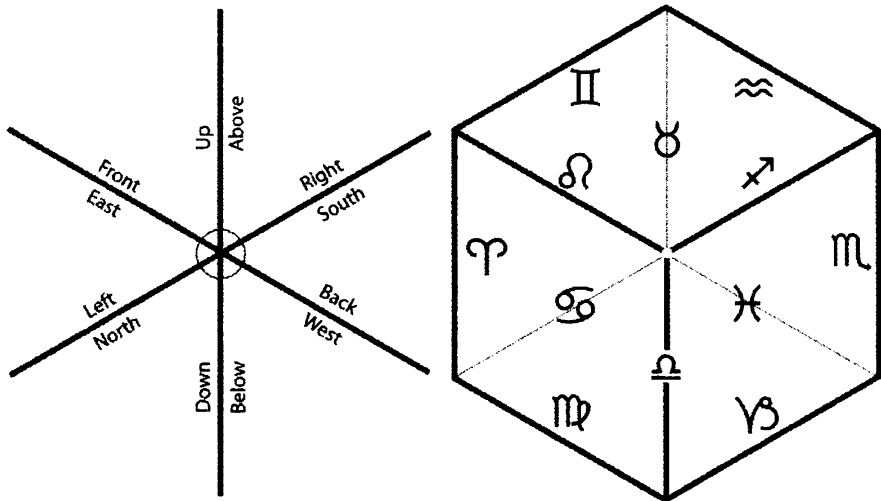

Cube of Space modified from Kaplan (1991) and Townley (1993).

The figure at the left shows the axes through the middle of the cube in isometric projection. It would fit inside the cube with the ends coming to the center of the six faces.

The analysis of the trigrams, by analogy, respects *Liber XXXI* III: 47, which says:

For in the chance shape of the letters (trigrams)
and their relation to one another (sequence of
trigrams) are mysteries....

Cube of One

The interpretation of the Cube of Space using *Trigrammaton* takes a different perspective from the central point of view of Kaplan (1990) and Townley (1993). Instead, the trigrams are viewed in nested cubes, beginning at the low corner (Malkuth, ☷, 333). Standing on that apex, a diagonal axis of the cube extends upward through the center to the opposite apex (Kether, ☰, 111).

In the lower right corner is the Cube of One. It contains a single homogeneous trigram with only Yin lines, ☷, 333. It represents the Material World, the World of Assiah. The material world has been recognized since the dawn of history and likely even before.

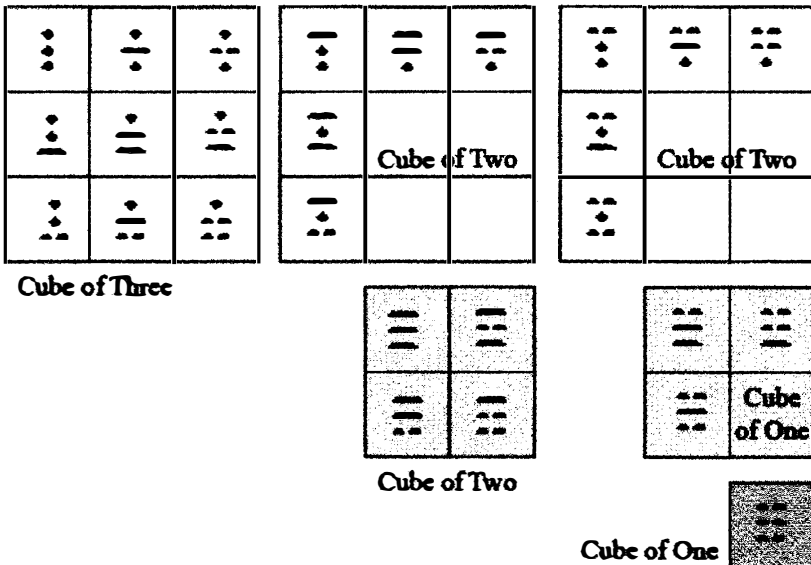









Cube of Two

The Cube of Two has eight trigrams, arranged $2 \times 2 \times 2$. The trigrams are the same as in the *I Ching*. The *I Ching* goes back to the Zhou Dynasty beginning in 1122 b. c. e. The trigrams have only Yang (--) and Yin (-) lines. There are no Tao (•) lines. The trigrams are organized into four levels, indicated by the number of Yang lines. The trigram, with no Yang lines, is the vessel of Malkuth in Assiah, the Cube of One. The Veil of Paroketh separates it from the World of Yetzirah.

Six trigrams have both Yang and Yin lines. They represent the vessels of the six sephiroth in Yetzirah. Some call this the Astral World. Those with two Yangs face Da'ath and are called fathers. Those with two Yins face Malkuth and are called mothers.

The sequence in *Trigrammaton* deals with the Fathers before starting the Mothers.

 = 222	Da'ath in Da'ath
 = 223,  = 232,  = 322	Fathers in Yetzirah (= I Ching fathers)
 = 332,  = 323,  = 233	Mothers in Yetzirah (= I Ching mothers)
 = 333	Malkuth in Assiah

The Fathers have two Yang lines. The remaining Yin line moves from bottom to middle to top. They share a face with Da'ath. The Mothers have two Yin lines. The remaining Yang line moves from top to middle to bottom. The three share a face with Malkuth. This causes the number to appear out of numerical order.

One trigram has only Yang lines. This is Da'ath, , 222. The QT model has Da'ath is in its own World. It occupies the center of the Cube of Three. Da'ath is unseen. When looking up from Malkuth within the Cube of Two, the middle point indicates its position. It shows when the layers of the cube have been separated.

Cube of Three

Eight units in the Cube of Three have been discussed under the Cube of Two. The remaining 19 units occur only in the Cube of Three. Four types occur—one trigram in the World of Atziluth, six trigrams forming the vessels of Briah, and 12 lights filling the sephiroth of Briah, Da'ath, Yetzirah and Assiah. The number of Tao (•) lines distinguishes them.

Three Tao lines indicate Kether, the World of Atziluth. It is pure light.

Two Tao define the vessels of Briah.

One Tao line indicates lights in all other worlds except Atziluth.

No Tao line indicates vessels in the Cubes of Two and One.

The text for most trigrams has capitalized words. These are clues to the character of the trigram and related sephira. When there are no capitalized words, the sentence subject is considered the most likely key word of the text. The individual trigram accounts give specific details.

The Sephiroth

In *Trigrammaton*, the text associated with each trigram provides information about the sephira. The sephiroth are treated in three-dimensional order. The vessels of the sephiroth each have an even number (none or two) Tao lines. Their lights have an odd number (one or three). Within each sequence the order of the sephiroth on the Tree of Life (QT and TL) is maintained.

Five worlds are distinct on the QT. Three of them, Atziluth, Da'ath and Assiah, occur on the Central Axis. Each contains one homogeneous trigram. The peripheral sephiroth are in two worlds with six sephiroth each—either Briah or Yetzirah. The vessels of Briah have two Tao lines. The vessels of Yetzirah have only Yin and Yang lines.

Sephiroth connecting to Atziluth (the Upper Triad) are only Briatic. Those connecting to Da'ath (the Middle Triad) are both Briatic and Yetziratic. Those connecting to Assiah (the Lower Triad) are only Yetziratic.

The dual occurrences of sephiroth on the Middle Triad reduce the total number of sephiroth to ten. Since Kether is not a sephira, Da'ath replaces it.

THE FIRST SERIES - THREE TAO LINES

LIGHT OF ATZILUTH — Archetypal World

⸙, 111, Kether, Nothing

**Here is Nothing under its three forms.
It is not, yet informeth all things.**

The World of Atziluth has only one trigram. The key words are **Nothing under its three forms**. This implies Nothing must also exist, but without form—a dilemma. It suggests the existence of the Cube of Four—Tetragrammaton. It is also **not**, but fills everything, $0 = 1 = 2 = \infty$. *Liber XXXI* I: page 1 (verse 4) says:

Every number is infinite: there is no difference.

The first trigram symbolizes the unrestricted light of Kether in Atziluth. There is no corresponding vessel for Kether. Since a light and vessel combined define a sephira, Kether is not a sephira. Rather, it is distinct from them—super-sephira. Its light penetrates all sephiroth. It illuminates the vessel and shows their characteristics. All these lights occur in the Third Series. A vessel characterizes a sephira. The light reveals it.

Lachower & Tishby (1979: 243ff) discuss the pre-existence of Keter (sic) as eternal will. They describe the impression of the En-Sof upon Keter, which is called *tehira* (תהירה) or *avir* (אוויר): The interpretation of the worlds in *Trigrammaton* differs from Lachower & Tishby I: 249ff:

The structure of the world of the sefiroth is like a single and indivisible unit of “essence and vessels”...The immanence of the divine essence means that the mystery of the unity of God must of necessity apply to the sefiroth as well...

The First Cause and system of sefiroth are two facets of existence of the one and only God: transcendent existence from above the sefiroth and immanent existence within them. It is possible that, in conformity with this approach, a new meaning is propounded here for the term *azilut* (emanation). It does not signify the way in which the sefiroth came into being. Their existence is “by way of *azilut*,” by the essence of God extending itself to, and dwelling within them, although an immanence both inseparable and continuous.

Divine immanence is not limited to the upper realms... There is no place where he is not, above without end, and below without limit... This view of an all-embracing immanence seems to destroy the division between the divine “sefiroth of emanation” and the lower regions. The latter are arranged in the form of three worlds (creation, formation and making—*beriyah*, *yezirah*, *asiyah*) each of which contains ten sefiroth or forces.

The identity of the ten sefiroth is not addressed specifically, but *Atziluth* is not included. The nature of *Kether* represents the light from the *Ain Soph* (not the *Ain Soph Aur*). The discussion indicates that it has not always been recognized as a *sephira*. When it is not, *Da'ath* is the substitute. There is a parallel discussion in Glotzer's (1992) presentation.

“Not” may have been included as “Nothing without form,” or may present a different situation. It is worthy of further meditation. What is “Nothing” without three forms? It could be the non-form, *qliphotic* or backside of the *TL* or *QT*, the *Ain*, the *Ain Soph Aur*, or something else.

Crowley (1996) assigns the letter *I* to this trigram and says:

Narrowed breath. Represents concentration, including aspiration. The letter *I* is equivalent of the Hebrew letter *Yod*, from which all the other ones are derived.

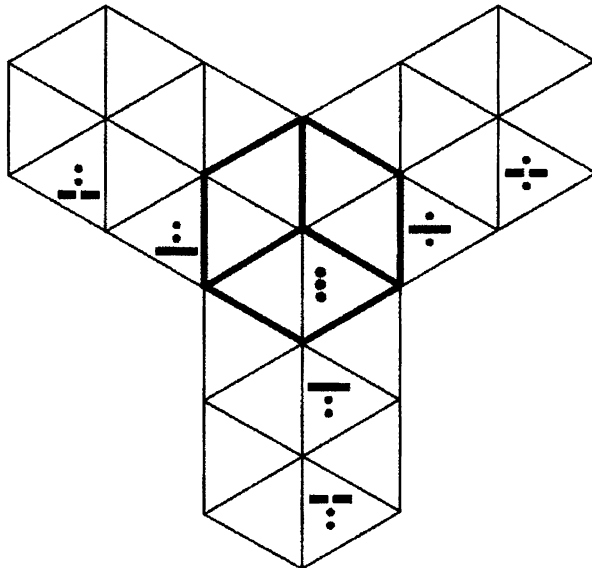
THE SECOND SERIES — TWO TAO LINES**Vessels Of Briah — Creative World**

Trigrams of Atziluth and Briah

(View from above Cube of Three, Atziluth with heavy outline)

The QT model has the same sephiroth, triads and pillars as the TL, but the qabalistic worlds are different. The First Series includes only Kether in the Archetypal World of Atziluth. The next six trigrams indicate the vessels of the Creative World of Briah. Each has two Tao elements. These occur in two triads. The Upper Triad, as Chokmah, Binah and Tiphareth, connects directly to Kether. Chesed, Geburah and Yesod in the Lower Triad do not.

☵, 112, Chokmah, Single One

**Now cometh the glory of the Single One,
as an imperfection and stain.**

The Yang line is in the lowest (least manifest) position. It destroys the purity and homogeneity of the Light of Kether. The key phrase is **Single One**, describing the Yang line at the bottom of the trigram.

This and the following trigrams occur in the Hebrew Second Emanation, *i.e.*, after the Breaking of Vessels. The vessels define an aspect of the World of Briah. Lachower & Tishby (1989): I: 248) state:

They are given the names of divine forces and attributes, not as substances that belong to the divine realm, but simply as vessels that receive the divine influence: “Hokhmah” (wisdom) is not called Hokhmah in its own right, but because of the Wise One who fills it from His source...

Crowley (1996) assigns the letter L to this trigram and says:

Passive undulation, without effort, unchecked.

He presents no argument for this assignment.

☶, 113, Binah, Weak One, Mother

But by the Weak One the Mother was it equilibrated.

The Weak One the Mother refers to the bottom broken line. This is the vessel for the Master of the Temple, the City of the Pyramids in Binah. It complements ☵, 112.

Crowley (1996) assigns the letter C to this trigram and says:

Vide S and K. (≈ See S and K.).

÷, 121, Chesed, Strength

Also the Purity was divided by Strength, the force of the Demiurge.

Purity describes the homogeneity of Kether, and 111 (☉). A Yang, **Strength**, is in the middle position. It also forms the mathematical sign for division (÷). The TL and QT attribute the Demiurge to Chesed.

The Demiurge evolved from being a benign architect of matter to the personification of evil. In *Timaeus*, Plato (1989) refers to the Demiurge as the fashioner and shaper of the material world and good. The imperfection comes from the work of the Demiurge on pre-existing chaotic matter.

In western mysticism and Gnosticism, the term Demiurge is the deity responsible for creating the physical universe and aspects of humanity. Gnostics distinguish between the original Creator and the Demiurge. The force of the Demiurge is one side of non-manifest vs. manifest, spiritual vs. material, good vs. evil. Zeus and Jupiter are traditionally assigned here. It sometimes presents the Demiurge as antagonistic to the Will of a Supreme Creator, and characterized as Satan/Ialdabaoth.

The Hebrew IHVH, יהוה, fits here. It is distinct from the Hebrew El, אל. Crowley (1996) assigns the letter H to this trigram and says:

Forcible addition of pure breath to other sounds. Represents effort.

÷, 131, Geburah, Cross

And the Cross was formulated in the Universe that as yet was not.

The text describes a four-element **Cross**. It is non-manifest, **yet was not**. It is in Briah above the Abyss.

The assignment of the trigram to Geburah follows in sequence. Its structure is complementary to the Strength of the Demiurge in Chesed. It parallels the male/female or strong/weak relationship between Chokmah and Binah.

The alternative name of the sephira is Pachad (פחד), awe, fear, dread. It is the opposite of Strength.

Crowley (1996) assigns the letter X to this trigram and says:

Combines K and S

This comment is a bit confusing when compared to that for trigram , 113. However, it appears that Crowley considered it the equivalent of the Chi, (X, χ) of Greek with its combination sound. The Greek Chi has the sound of a hard K.

, 211, **Tiphareth, Imperfection became manifest**

**But now the Imperfection became manifest,
presiding over the fading of perfection.**

The trigram has a Yang at the top line. Tiphareth occurs on the Middle Pillar on the TL and QT. It connects directly to Kether. Its symbols are also the phallus, and the Sun. The **Imperfection** is in the top line.

An axis extends along each edge from Kether. After Chokmah/Binah and Chesed/Geburah, Tiphareth/Yesod fills the third.

The imperfection of this and the following trigram are strongest. **Presiding over the fading of perfection** describes its Briatic position.

Tiphareth is in Briah here. The text includes **manifestation**, implying Yetzirah. As will be seen later, Chesed, Geburah, Tiphareth and Yesod each have two vessel trigrams — one briatic, one yetziratic.

Crowley (1996) assigns the letter T to this trigram and says:

The sexual onslaught. A less responsible form of D.

T is the shape of the trigram, showing its phallic nature. Why is this a less responsible form of D? Crowley provides no answer.

𐤒, 311, Yesod, Woman

**Also the Woman arose,
and veiled the Upper Heaven
with her body of stars.**

The trigram symbolizes **Woman** as the receptive force, 𐤒, 311. It complements the previous trigram. **Woman** is the counterpart of *Imperfection became manifest* of the previous trigram. The Upper Heaven indicates Nuit as the **body of stars** in Briah. With the previous trigram, the pair represents the Sun and Moon.

This is the lowest briatic vessel trigram on the QT. On the TL it is below the Abyss. On the QT, Yesod has both a briatic and yetziratic component.

The sequence of these six trigrams may seem out of order. It comes from a 3-d model being transformed into a linear arrangement.

Crowley (1996) assigns the letter Y to this trigram and says:

When distinct from I, dignifies the vowel to which
it is prefixed.

The assignment is based on the shape of the trigram. Cf. the previous T.

THE THIRD SERIES — ONE TAO LINE

LIGHTS FROM BRIAH TO ASSIAH

The Third Series includes lights for Chokmah to Malkuth. Only one Tao line (•) is present in each. The Tao element represents the esoteric secret, or light, of the Tree. There are twelve trigrams, but only three triads. Complications relate to the Brothers of the Left-hand Path (Upper Triad), Da'ath (Middle Triad) and the Black Brothers (Lower Triad). The QT model resolves them.

On the TL, the Abyss is located above Chesed and Geburah, and below Chokmah and Binah. The two phases and the Briatic nature of sephiroth of the Middle triad are not differentiated on the TL. Both the QT and the Cube of Three model sharply define the position of the Abyss. On the QT, the

Abyss is at the Middle Triad, common to Briah and Yetzirah. The QT indicates that Knowledge and Conversation with a Holy Guardian Angel occurs within the Middle Triad. The initiate is below the Abyss. He crosses between Yetzirah and Briah when traversing the sephiroth of the Middle Triad.

On the Cube of Three model, the Abyss occurs between the Cube of Two and Cube of Three, the Creative World of Briah and the Formative World of Yetzirah.

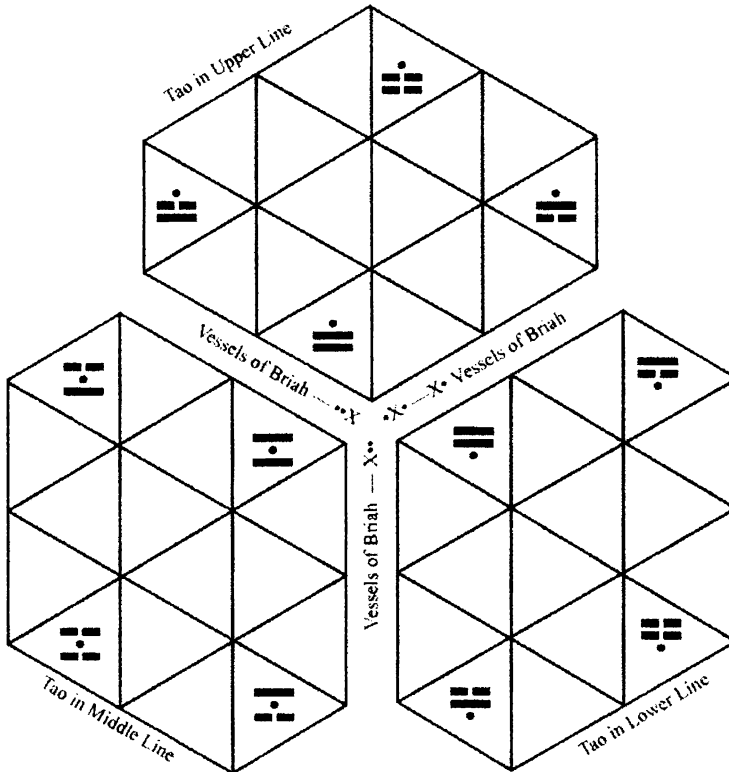

The Light trigrams for the Sephiroth Series Three trigrams on the Cube of three

Upper Triad — Briah

☵, 122, Chokmah, giant/Spirit

**Now then a giant arose, of terrible strength;
and asserted the Spirit in a secret rite.**

This light fills the vessel of trigram ☵, 112, Chokmah, the Single One, a **giant**. The two Yang lower lines represent reinforced **terrible strength**. They augment the vessel of Chokmah. The **secret rite** may be the mating of the giants with men.

The **giants** of Chokmah relate to the Nephilim. The Nephilim (נפִלִים) are the *fallen ones*, angels descended from Heaven. The Hebrew root נפל means *to fall*. In *The Dead Seas Scrolls Translated* (Martinez, 1992: 248) the Watchers, sons of the sky, lusted for the daughters of men. They mated and defiled them by teaching sorcery and incantations. The daughters gave birth to giants, who were born upon the earth.

The Book of Enoch Chapter VII: 1-15 (Laurence, 1983) gives a long account of the mating between fallen angels and the daughters of men, forming giants. See also the Biblical quotation found in *Genesis* 6: 4: The Nephilim were on the earth in those days—and also afterward—when the sons of God went to the daughters of men and bore to them the heroes of old, the men of the name.

Enoch, Chapter LXIII: 1 states: I heard the voice of an angel saying:

These are the angels who have descended from heaven to earth, and have revealed secrets to the sons of men and have seduced the sons of men to the commission of sin.

This trigram represents the light of the giants, the Nephilim who mated with the daughters of men in the secret rite, and defiled them. In doing so, the secret of royalty and priesthood (Lévi, 1913) was brought down to men—also the possibility of sin. The resulting giants (Titans) typified brute force and unbridled appetite. They fought together for the world, which escaped only by immersions in the waters of the deluge when traces of the past were effaced.

In Thelema, this sephira sometimes has been associated with the Eleventh Degree. The trigram puts it above the Abyss, and beyond the Master of the Temple. Following the pattern, this and the following trigram are complementary.

Crowley (1996) assigns the letter P to this trigram and says:

As to B as K is to (hard) G. Bursting of a bud as against that of a fruit.

⚊⚊, 123, **Binah, Master of the Temple**

**And the Master of the Temple balancing all things arose;
his stature was above the Heaven and below Earth and Hell.**

This trigram and text are easy to assign to a sephira. The **Master of the Temple** is attributed to Binah, the Great Sea.

Lévi in *History of Magic* (1913: 61) states:

Equilibrium is the key of occult science. Unbalanced forces perish in the void. So passed the kings of the elder world, the princes of the giants. They have fallen like trees without roots, and their place is found no more. Through the conflict of unbalanced forces the devastated earth was void and formless, until the Spirit of God made for itself a place in heaven and reduced the mass of waters. All the aspirations of Nature were directed then towards unity of form, towards the living synthesis of equilibrated forces; the face of God, crowned with light, rose over the vast sea and was reflected in the waters thereof. His two eyes were manifested, radiating with splendour, darting two beams of light which crossed with those of the reflection. The brow of God and His eyes formed a triangle in heaven, and its reflection formed a second triangle in the waters. So was revealed the number six, being that of universal creation.

Lévi (1913: 62 ff) continues:

The Master here emerges from the depths of the Abyss into the Great Sea. A human figure ascending slowly and emerging from the water. He symbolizes the days or acts of creation. The form stood at length erect, having one foot upon the earth and one upon the waters. Beholding itself at full length in the ocean of creation, it breathed on its own reflection and called its likeness into life. It said: Let us make man—and thus man was made...Hereby is man but the shadow of a shadow, and yet he is the image of divine power...to him is the earth given as dominion. Such is Adam Kadmon, the primordial Adam of the kabalists. Such is the sense in which he is depicted as a giant.



Eliphas Lévi (1913), *History of Magic*, facing p. 40

In describing Binah, the 13th Æthyr in *The Vision and the Voice* says:

Beautiful art thou, O Babylon, and desirable, for thou hast given thyself to everything that liveth, and thy weakness had subdued their strength. For in that union thou didst understand. Therefore art thou called Understanding, O Babylon, Lady of the Night!

O Babylon, Babylon, though mighty Mother, that ridest upon the crownèd beast, let me be drunken upon the wine of thy fornications; let thy kisses wanton me unto death, that even I, thy cupbearer, may understand.

This trigram has the three different line elements in descending order, from bottom to top. Note that its inverse is the trigram for the Black Brothers. On the TL and QT, Binah is definitely above the Abyss. This trigram is the light of the City of the Pyramids.

This light fills the briatic vessel of trigram $\text{⚊}\text{⚋}\text{⚋}$, 113, Binah, the Mother. Crowley (1996) assigns the letter A to this trigram and says:

Open unmodulated breath, (ah).

This is probably the sound produced by just opening the mouth and voicing a vowel. There is also some thought that the A could be assigned to Da'ath as part of an IAO formula.

$\text{⚋}\text{⚋}\text{⚊}$, 132, Brothers of the Left-hand Path

**Against him the Brothers of the Left-hand path,
confusing the symbols.**

**They concealed their horror [in this symbol];
for in truth they were $\text{⚋}\text{⚋}\text{⚊}$.**

C. F. Russell (1930) points out that:

Every true system of initiation provides the candidate with a trinity of trials or crises, the first two of which are in their proper order called

“The Angel” and “The Abyss.” The second of these is the real turning-point, where the Left-hand Path and the Right-hand Path diverge. The Left-hand path never reaches the third trial or ceremony of initiation. But the Brothers of the Left-hand path have so confused the symbols that the mere terms, black and white, cease to have any meaning with reference to either path.

This trigram of light has no corresponding vessel in the Second or Fourth Series. This explains its absence on the TL. The Brothers of the Left-Hand Path are usually treated as off the Tree, *i.e.* beyond the sephiroth. The TL considers the Upper Triad as Kether, Chokmah and Binah. There is a space below Chokmah/Binah on the Middle Pillar that is sometimes filled by Da’ath.

Chokmah and Binah occupy the two fixed peripheral matrix positions. On the QT, the Brothers of the Left-hand Path occupy the Upper Triad position in Lower Phase. Tiphareth occupies it in Upper Phase.

The trigram represents a discarnate fallen one from heaven. The BLP (⚊⚊) are distinct from the Black Brothers (see trigram ⚊⚊, 321). This is the only trigram with text referring to another trigram. Two points require clarification:

- 1) What is the definition, nature and role of the Brothers of the Left-hand Path?
- 2) How are they related to the Black Brothers?

A clue to the Brothers of the Left-hand Path is found in the last sentence:

They concealed their horror [in this symbol]
for in truth they were ⚊⚊.

The two phases of the peripheral sephiroth of the QT show this. The Central Axis is omitted.

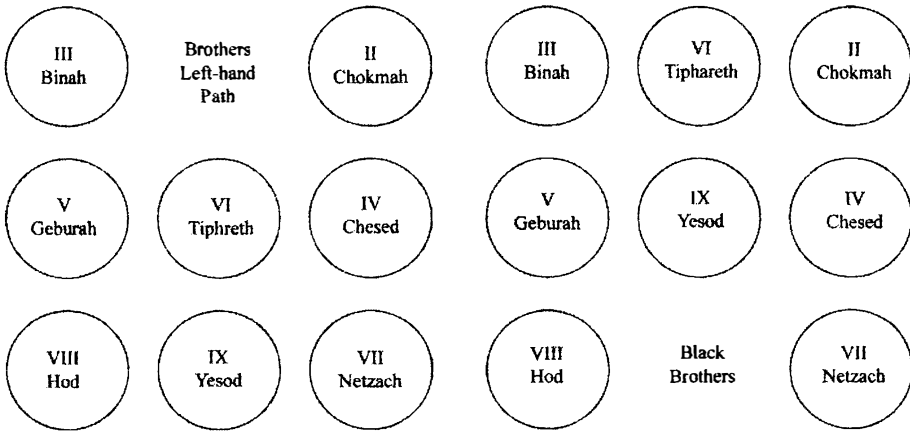

Peripheral Sephiroth — Lower Phase

Peripheral Sephiroth — Upper Phase

In *Magick*, Appendix III, “Notes on the Nature of the Astral Plane,” Crowley considered the TL a universal model, so it should contain the BLP and BB. He stated:

The Qabalah maps ourselves by means of a convention. Every aspect of every object may thus be referred to the Tree of Life, and evoked by using the proper keys.

While *Trigrammaton* relates the Brothers of the Left-hand Path and the Black Brothers, the names and trigrams indicate difference. Crowley has very few references to the BLP, but many to the BB. The BLP are named here in the Class A text of *Liber Trigrammaton* and in the 11th Æthyr of *The Vision and the Voice*. They are also mentioned by name in the commentary to the Class B *Voice in the Silence, Seven Portals*, verses 23 and 24. Elsewhere they are combined with Black Brothers, or are not distinctly distinguished.

The *Trigrammaton* text says that while the BLP appear to be above the Abyss, in reality they are the BB below it.

Trigram \equiv , 132, is the complement left-hand to the right-hand Master of the Temple. but in a different way from Chokmah (\equiv). It also equates to the Black Brothers trigram \equiv , 321, that is the inverse to the Master of the Temple. The BLP are distinct above the Abyss (Upper Triad), while the Black Brothers are distinct below the Abyss (Lower Triad).

The Left-hand Path

The Left-hand Path of Hinduism and Buddhism is associated with tantra. Tantra is a system of beliefs and practices intended to stretch the mind and guide adherents to higher knowledge (Feuerstein, 1998). It celebrates divinity in every being and thing. Adepts introduce practices and methods that are unusual and even sinful and degraded within traditional contexts. Some schools use ritualistic sex (maithuna).

Flowers (1997) defined two approaches from this in practical terms.

The Right-hand Path is the way of union with universal reality (God or Nature). The individual self is annihilated, and becomes one with the divine or natural order. In contrast, the Left-hand Path involves non-union with the objective universe. It isolates consciousness within the subjective universe, in a state of self-imposed psychic solitude, leading to perfection. The objective universe then harmonizes itself with the will of the individual psyche. It normally rejects conventional “good,” and embraces “evil” to gain permanent enlightened existence. By going against the accepted ways (antinomianism), the individual seeks to gain spiritual power.

The western Left-hand Path is often associated with Satanism. Christians perceived many traits of the Left-hand path philosophy and religion as evil. Such seems to be true in some Gnostic texts.

In *Magick*, Chapter 21, Of Black Magick, it states:

The contrast between the Master of the Temple and the Brothers of the Left-hand Path is described. They practice Black Magic, and have not given every drop of blood into the cup of Babalon. They have trampled Love in the Race for self-aggrandizement.

In *Equinox III (9): Liber 194, An Intimation with Reference to the Constitution of the Order* (O.T.O.), it says:

28. Of the Eleventh Degree, its powers, privileges, an qualifications, nothing whatever is said in any grade. It has no relation to the general plan of the Order, is inscrutable, and dwells in its own Palaces.

In *Liber LXXI, The Voice in the Silence*, fragment 3: 24, Crowley identifies the “Brothers of the Shadow” belonging to the Left-hand Path, who terminate their initiation in Da’ath. He notes the description from *The Vision and the Voice*, 11th Æthy, viz:

It will be remembered that the Knowledge and Conversation of the Holy Guardian Angel is attributed to Tiphareth, while the Exempt Adept is in Chesed; how is it then that a Black Magician, a Brother of the Left-hand Path, can ever reach that grade? The answer is given in the eleventh Æthy; when the Exempt Adept reaches the Frontier of the Abyss, his Holy Guardian Angel leaves him, and this is the one supreme terror of that passage. His Knowledge and Conversation should afterwards fall away into that blind horror whose name is Choronzon...It is for this reason that the Great White Brotherhood admits no essential connection with the lower branches affiliated to The Order. At the same time, the Brothers of the A.∴ A.∴ refuse none. They have no objection to any one claiming to be one of Themselves. If he does so, let him abide by it.

The **horror** in *Trigrammaton* may refer to Choronzon who inhabits the Abyss. In *The Vision and the Voice*, 12th Æthy, it states:

And this is the meaning of the Supper of the Passover, the spilling of the blood of the Lamb being a ritual of the Dark Brothers, for they have sealed up the Pylon with blood, lest the Angel of Death should enter therein. Thus do they shut themselves off from the company of the saints. Thus do they keep themselves from compassion and from understanding. Accursed are they, for they shut up their blood in their heart.

The related footnote associates the BLP and BB, it says,

Here is the first account of the Black Brothers of the Left Hand Path. Each Exempt Adept must choose between the Crossing of the Abyss to become a Master of the Temple, and the building of a False Tower of Egoism therein.

Crowley (1996) assigns the letter J to this trigram and says:

Like soft G.

The comment refers to the sound, but does not provide an independent clue about the nature of the J as related to this trigram.

Middle Triad, Central Axis — World of Da'ath

⚡, 133, Da'ath, Water/Abyss

**The master flamed forth as a star
and set a guard of Water in every Abyss.**

On the TL, Da'ath sometimes shows between Kether and Tiphareth. On the QT, Da'ath occupies the Middle Triad position on the Central Axis.

The text describes this trigram as a **star**, a pentagram. This light fills the vessel **⚡**, 222. This is the first light filling a vessel from the Fourth Series. It occurs at the Abyss.

In a terrestrial sense, the **Abyss** is the deepest part of the ocean, *e.g.*, the Marianas Trench. It is a deep chasm metaphor, an uncrossable barrier between two states. The Guard of Water is easy to visualize below the Great Sea of Binah.

The initiate faces the horror, Choronzon, when crossing the Abyss. The 10th Æthyr of *The Vision and the Voice* records Crowley's experience at the Abyss. His ritual for invoking Choronzon included a triangle into which Choronzon was invoked, a circle for the scribe, and a secret place for the seer. In that æthyr, Choronzon continually tries to seduce, distract, or taunt the scribe. The scribe was protected while within the circle.

Choronzon hath no form, because he is the maker of all form; and so rapidly he changeth from one to the other as he may best think fit to seduce those whom he hateth...

And, because he is himself, therefore he is no self; the terror or darkness, and the blindness of night, and the deafness of the adder, and the

tastelessness of stale and stagnant water, and black fire hard, and the udders of the Cat of slime; not one thing, but many things, Yet, with all that, his torment is eternal...

My name is three hundred and thirty and three, and that is thrice one. Be vigilant, therefore, for I warn thee that I am about to deceive thee...

Thou canst tell me naught that I know not, for in me is all knowledge: Knowledge is my name. Is not the head of the great Serpent arisen into Knowledge?

All is dispersion.

In the end, the Seer took the Holy Ring, and wrote the name Babalon, that is victory over Choronzon, and he was no more manifest.

Da'ath is the center of the QT model. On the TL, Tiphareth eclipses it. On the QT, the World of Da'ath (Knowledge) interpenetrates peripheral sephiroth at the Middle Triad. It also interpenetrates Kether and Malkuth on the Central Axis. The TL Middle Pillar contains Tiphareth and Yesod, plus Kether (displaced upward) and Malkuth (displaced downward). These four appear in a straight line, the effect of distortion, an illusion.

In *Trigrammaton*, the light of Da'ath comes from the Cube of Three. Its vessel occurs in the Cube of Two.

Da'ath connects the non-manifest to the manifest. An initiate uses his magical or mystical inertia (\approx to **flame forth** from manifestation) to cross the Abyss to Binah on the non-manifest side.

Crowley (1996) assigns the letter W to this trigram and says:

When distinct from U represents the operation of choice.
U does this to some extent. (Will, word, way).

Another defensible letter would be A, by shape as the five pointed star. It could then serve as the transform between the I (in Kether) and the O (in Malkuth) in the IAO formula.

Middle Triad — Peripheral Sephiroth Briah/Yetzirah

☰, 212, Chesed, Light of Purity

**Also certain secret ones concealed the Light of Purity
in themselves, protecting it from the Persecutions.**

The trigram ☰, 212, has two Yang lines surrounding [concealing] the Tao. This is the light for the Demiurge, the Creator God of vessel trigram ☳, 121, in Briah and vessel ☱, 223 in Yetzirah.

The **certain secret ones** are not identified here but the Yang lines indicate males. They may be priests, adepts, monks, or seekers of the mysteries.

The **Light of Purity** is light in extension from Kether, trigram ☰, 111, or the secret seed of the Hebrews.

Alchemists, students of the Great Work, reported their results in a way that was not easily interpreted. Allegory and symbolism were used. By this, they kept the enemy from abusing or debasing the Great Work. For a significant period in history, monasteries were guardians, maintaining knowledge in libraries and scriptoria. The **Persecutions** would be the library burnings, ignorance, or against spreading the Word during Dark Ages.

Crowley (1996) assigned the letter O to this trigram and says:

The breath concentrated and directed. As to I as magic is to mysticism.

☷, 213, Geburah, Sons and Daughters

**Likewise also did certain sons and daughters
of Hermes and Aphrodite, more openly**

The **sons and daughters of Hermes and Aphrodite** protect the Tao. They may be initiates, mystics or magicians, but both sexes are included, and sexual congress implied. The Yang and Yin lines above and below the Tao symbolize this. **More openly** implies acceptance and import of sexual union.

The corresponding vessels are ☳, 131 (in Briah), Cross and ☱, 322 (in Yetzirah), Geburah, Water, below.

As an alchemical symbol, the hermaphrodite is the child of Hermes (wisdom) and Aphrodite (emotion, love). A hermaphrodite represents a balance

reached in the Great Work, completing the spiritual and physical transformation of the spirit of the individual. It does not refer only to physical sex. In the mystical union, the spirit unites with manifestation. The spirit becomes flesh and the union is god-like.

Crowley (1996) assigns the letter G (hard) to this trigram and says:

Opening as I to devour. (Soft?)

Light Trigram Arrangement

This is the mid-point in the sequence of the light trigrams with one Tao element. The first six have Briatic, the last six have Yetziratic function. The light in the Middle Triad sephiroth fills both.

Before and after this point the trigrams are paired and become reflections or contrasts between one another. This follows the principle of *As above, so below*.

☰, 122 compare to ☷, 221

Giant of terrible strength compare to the Horror of Time
Titans and Saturn

☱, 123 compare to ☴, 231

Master of the Temple compare to the Sensualists
IXth Degree and XIth Degree

☵, 132 compare to ☶, 321

Brothers of the Left-hand Path compare to the Black Brothers
Illusion of existence above and below the Abyss

☱, 133 compare to ☴, 331

Master/Guard of Water and Abyss compare to the Soul of filth and weakness
Water and Earth

☰, 212 compare to ☷, 313

Secret ones (priests, male) compare to the Holy nuns (female)
Each held the secret in their lives

☱, 213 compare to ☴, 312

Sons and daughters of Hermes and Aphrodite compare to the Enemy
Changing attitudes toward sex

The six peripheral sephiroth of Briah are complementary to the six in Yetzirah. The formula of *As above, so below* is met strictly. The Yetziratic sephiroth form the Holy Hexagram when viewed from Assiah.

⚊⚊, 312, Tiphareth, Enemy

**But the Enemy confused them.
They pretended to conceal that Light
that they might betray it, and profane it.**

This middle trigram of *Liber Trigrammaton* identifies Tiphareth, the traditional center of the TL.

Who is the **Enemy**? The trigram is the inverse of the previous one, though the next in a base three number sequence Tiphareth is considered the place of balance and beauty. As Keats (1819) wrote: "Seek beauty, for in beauty is truth revealed." Could this be the light of the central Tao representing Sud (𐤌𐤎), or knowledge in Da'ath? Secrecy and ignorance oppose the balance of intellect and emotion required for the Great Work.

The antecedent of **They** is the sons and daughters of Hermes and Aphrodite. There is a parallel in the image of Babalon riding the Beast, and holding the light. See the Thoth tarot card for Teth, and the Mercuric Sigil for Teth in *Liber CCXXXI*.

The corresponding vessels are trigram ⚋, 211, Imperfection in Briah and ⚊⚊, 232, Tiphareth, Sun in Yetzirah.

Crowley (1996) assigns the letter Z to this trigram and says:

An irritated or excited form of S, emphasizing elements of anger and alarm

Z is the voiced complement to S. The latter emphasizes hissing or buzzing.

The assigning of Z to this trigram has no supporting statement.

Lower Triad — Yetzirah

☵, 313, Netzach, Holy Nuns

Yet certain holy nuns concealed the secret in songs upon the lyre.

This is the first light trigram for a Lower Triad sephira, though it still has a Tao element in the middle line. The Yins imply females, **holy nuns**, associated with emotion, love, and Venus.

The mythic reference may be to Sappho and her students on the island of Lesbos, whose capital was Mytilene, a city referred to Netzach in Thelemic ritual. Sappho came from an aristocratic family. The daughters (? = nuns, virgins) of the elite were trained in singing, lyre playing and dancing in salons operated by older women. She operated one of the more distinguished salons of her time.

Sappho was perhaps the most famous poetess of ancient Greece. She lived on Lesbos from about 630 B.C.E. Poetry was part of the musical art. She wrote poems for accompaniment to the **lyre**. She showed a shift from the view of the gods and muses to a more personal approach. Her poetry was erotic, lascivious, active and passionate. She is sometimes referred to as the Tenth Muse, the Muse of Lyric and Erotic Poetry. Her poetic legacy is devotion to Aphrodite and lust for females. Then the world was patriarchal. Extra-marital sex was more accepted, but marital decorum was strictly defined. Affairs were pursued with abandon.

Her *Hymn to Aphrodite* may have been composed for a public rite celebrating the status of the women's mysteries. A poetic fragment quoted by Athenaeus in the third century C.E. invokes Aphrodite (Hare, 2000):

Come hither foam-born Cyprian Goddess, come,
And in golden goblets pour richest nectar
All mixed in most ethereal perfection,
Thus to delight us.

or otherwise translated (Mythography, 1997):

And here, Queen Aphrodite, pour heavenly nectar into gold cups and fill them gracefully with sudden joy.

The **songs upon the lyre** also suggest the fundamental forces that sustain existence. Music symbolizes the order and harmony of creation and a way to invoke the gods. The enlightened soul was symbolized by the sounds. Cirlot (1971) quotes the following:

The lyre produces its sounds through the horns forming the sides of its structure, and representing the relationship between earth and heaven. It may also be a euphemism for the yoni, implied by similarity of shape.

In this and the previous three trigrams, the word **conceal** is repeated. It is possible to interpret these four trigrams as protecting, or in a sexual context relating to transmission of the force, word or seed.

Crowley (1996) assigns the letter B to this trigram and says, without adding any explanation:

Bursting forth. Phallus and Vulva. Kissing.

☰, 221, Hod, Horror of Time

**Now did the Horror of Time pervert all things,
hiding the Purity with a loathsome thing,
a thing unnameable.**

The trigram has strong male lines, with the two Yangs at the top. It is the inverse of trigram ☷, 122, the giant of terrible strength. It is the light for vessel trigram ☱, 332, Hod. Who or what is the **loathsome, unnameable thing?**

Hod characterizes intelligence, reason, because, possibly hiding the Tao. Is there any difference between *conceal* of the previous statements, and *hiding* here?

The **Horror of Time** may refer to the myth of Saturn (as Time) eating his children, the concept of time or death, or Yang/Yin. It may be Choronzon and the Abyss.

The common base that binds these alternatives is the idea of suppression or destruction of the Tao. *Liber XXI I: 41*: “The word of sin is restriction.” Crowley (1996) assigns the letter F to the trigram as:

Compound of P and H.

This is purely descriptive of the sound.

☱, 231, Yesod, Sensualists

**Yea, and there arose sensualists upon the firmament
as a foul stain of storm upon the sky.**

This trigram is the light for Yesod. On the QT, the corresponding vessel trigrams are ☰, 311 (Upper Phase, in Briah), Woman and ☷, 323 (Lower Phase, in Yetzirah). It is the fourth sephira on the QT that has vessels in both Briah and Yetzirah. **Sensualists** are those who relish the physical world, esthetics, and sexual pleasure. The sensualists may be those using personal gratification in seeking the Tao.

The **firmament** is the arch of the sky, through which the moon courses around the earth. The moon symbolizes illusion. The moon is unique in breaking the continuity of the starry night sky. As it moves, it blocks the view of stars around it with its reflected light.

The inverse of this trigram is ☳, 132, the Brothers of the Left-hand Path. Crowley (1996) assigns the S to this trigram, noting:

Defiance, warning, etc.

A footnote to the comment indicates a [variant reading, “defense.”]

☱, 321, Black Brothers

**And the Black Brothers raised their heads;
yea, they unveiled themselves without shame or fear.**

This is the last trigram in the Third Series without a vessel. It is the alternate of the Brothers of the Left-hand Path described in ☱, 132. The Tao line moves from the top to the bottom.

The text says that the **Black Brothers** make public their presumed attainments. This is certainly not the understanding for Masters of the Temple, who use the powers of the Sphinx.

The text suggests the concept of resonance and the rationale for the QT. There are two phases, one for each of two positions for Tiphareth and Yesod. Tiphareth can be in the Upper or the Middle Triad. Yesod is directly below it. The two phases are exclusive.

Crowley (1996) assigns M to this trigram and says:

The Will to Die.

Lower Triad, Central Axis — Assiah

☱, 331, Malkuth, Soul of Filth and Weakness

**Also there rose up a soul of filth and of weakness,
and it corrupted all the rule of the Tao.**

This trigram symbolizes light in the World of Assiah. It is the inverted pentagram to ☱, 133, Da'ath, knowledge. It enlightens **filth, weakness, and corruption**—a perception of Malkuth and Earth. These lights fill the vessels for Phallus (☱) and Vulva (☱) that form the Central Axis within the Cube of Two.

	Da'ath	Malkuth
Vessel	☱	☱
Light	☱	☱
	Proactive	Receptive

Da'ath is knowledge or light. Malkuth is dark and hidden.

The Way of the Tao is change and flexibility. It is a process. When the Tao stops moving, it does not exist. From Malkuth the light can only move toward Kether.

Crowley (1996) assigns the letter N to this trigram and says:

The vibration which includes Life and Death as complementary curves.

N is the traditional letter of Death. In a sense, Malkuth is the most manifest, farthest from the light of Kether, so the assignment here is understandable.

The Shekinah in Malkuth suggests 0 may be the letter for Malkuth, the most receptive sephira on the TL and QT. This would complete the IAO formula as lights on the Central Axis.

The Fourth Series – No Tao Lines

Vessels of Da'ath, Yetzirah and Assiah

The eight remaining trigrams have only Yang and Yin lines. The *I Ching* is extremely old and well documented. The *I Ching* forms hexagrams by combining two trigrams. The eight trigrams (the Cube of Two) comprise the whole basis of this Chinese system.

The sequence of the trigrams has varied since ancient times, but the interpretation is consistent. The traditional chart is 2-d. The text in *Trigrammaton* indicates an extension to a 3-d Cube of Four ($4 \times 4 \times 4$).

Wilhelm/Baynes (1967, p. 262) includes the beginning of the Eighth wing as follows:

In ancient times the holy sages made the Book of Changes thus:

They invented the yarrow-stalk oracle in order to lend aid in a mysterious way to the light of the gods. To heaven they assigned the number three, and to earth the number two; from these they computed other numbers.

They contemplated the changes in the dark and the light and established the hexagrams....

They put themselves in accord with the tao and its power...and laid down the order of what is right...they arrived at an understanding of fate.

It comments further:

The fundamental principles of the world are heaven and earth, spirit and matter. Earth is the derived principle... Heaven is the ultimate unity...

The three axes of the Cube of Three correlate to the pillars on the TL and QT. This leaves the Heaven/Earth (Chinese tradition), or Phallus/Kteis (Crowley), or Creative/Receptive dimension. The Fu Shi arrangement (Wilhelm/Baynes, 1967) is a distribution of the four crossing at a common point. The TL combines this axis with the Tiphareth/Yesod axis to form a Middle Pillar. The QT separates the Tiphareth/Yesod axis from the Phallus/Kteis axis. The four remaining trigrams relate to the alchemical elements.

World of Da'ath

Da'ath usually is not on the standard TL diagram. As a "false sephira," its existence is declared moot. Calling it a separate World on the QT is a concept different from the TL model.

In *Trigrammaton*, the World of Da'ath is a single homogeneous sephira, a vessel filled with light. On the TL it is directly behind (eclipsed by) Middle Triad sephiroth. The God name in Assiah for Tiphareth is יהוה אלוה ודעת (YHVH Eloah v Da'ath) shows a qabalistic awareness of Da'ath behind Tiphareth.

Gikatilla (1994), a 13th Century qabalist, in his *Gates of Light* discusses the sephiroth, which he calls spheres. The title of the book says that these spheres are gates and have light. On pages 226 to 232, he discusses DAT (= Da'ath). The significance of his discussion is:

1. The essence of DAT is the Middle Line, a reconciler of the lateral ones.
2. The Middle Line reaches to Kether.
3. Middle Line ascends to Ain Soph, to the Infinite.
4. DAT is considered third to Chokmah and Binah, and normally found between Gedulah and Geburah [Chesed and Geburah]
5. DAT ascends to Netzach and Hod, passes through Gedulah and Geburah to Chokmah and Binah until it reaches Kether.
6. The essence of IHVH, who arbitrates all Names from above to below, on all sides.

7. It passes through all, like the trunk of a tree, until it reaches Ain Soph.
8. The essence of DAT is the Sphere that includes all the spheres.
9. It is a mystery.

These thoughts divide Gikatilla's *Middle Line*. They seem to separate Da'ath from Tiphareth, as on the QT. Da'ath rises from Malkuth up the Central Axis, past the three triads, and ends at the Ain Soph. See the further discussion under the vessel of Da'ath trigram \equiv , 222, below.

Lachower & Tishby (1989, I: 247-248) says (attributing it to the Zohar II: 247b):

The deeds of the Creator are revealed and accomplished by means of the ten sefiroth, which were formed in order to be used as instruments for the divine activity: "You are He who produced the ten tik-kunum (regulators), which we call ten sefiroth, so that through them you might guide the secret worlds that are not revealed, and the worlds that are revealed." They are given the names of divine forces and attributes, not as substances that belong to the divine realm, but simply as vessels that receive the divine influence.

Kaplan (1990: 23-25) describes the equivocal nature of Da'ath as a sephira as follows:

With Wisdom, God established the earth, and with Understanding. He established the heavens, and with his Knowledge, the depths were broken up: (Proverbs 3:19, 20. It is likewise written, "With Wisdom a house is built, with Understanding it is established, and with Knowledge its rooms are filled:

...Knowledge, however, is not a Sefirah, but merely the point of confluence between Wisdom and Understanding. In many ways however, it behaves as a Sefirah, and it is thus often included among them.

Da'ath is the connection above to the Heaven, and below to the Earth. The assignment of Da'ath as a sephira and to an independent world is not a new concept. Its definition matches the other traditional sefiroth, except for Kether.

☰, 222, Da'ath, Heaven, ○

**Then only was Heaven established to bear sway;
for only in the lowest corruption is form manifest.**

Four trigrams in the Fourth Series have reference to heaven.

The light of pentagram ☰, 133, fills the vessel ☰, 222, of Da'ath, forming a sephira. This vessel trigram is the first to have no Tao line.

The *I Ching* calls this trigram Ch'ien, **Heaven** and relates it to the summer season. In the Fo Hsu or primal arrangement, it is south, at the top of the diagram. With K'un, winter, it forms the north/south axis (Wilhelm/Baynes, 1967). It represents the great law of existence.

Crowley's (1974) commentary on *Trigrammaton* relates this trigram to Phallus, and the letter E. He describes the letter as softened, but otherwise unmodulated breath.

World of Yetzirah

The World of Yetzirah has six sephiroth. Its heterogeneous vessel trigrams have no Tao element. They complement the six sephiroth of Briah. They share four—Chesed, Geburah, Tiphareth and Yesod, which occur in the Middle Triad in at least one phase of the QT.

☰, 223, Chesed, Violent light, Air or Æthyr, △ Also did Heaven manifest in violent light,

Heaven is the abode of gods. If the Demiurge is here, it resides here by definition. However, this is not the Heaven of the *I Ching*.

The **violent light** is strong light from above, extended from Kether. It becomes manifest by filling trigram vessel ☰, 223. The text ends in a comma, so that the subject continues to the next trigram.

This is the first of four unbalanced trigrams in the Cube of Two that relate to elements. The TL and QT assign Jupiter (≈ Zeus) to this sephira. The violent light is their thunderbolt. The sephira is on the Pillar of Mercy on the Middle Triad.

The *Sepher Yetzirah* I: 6 (Kaplan, 1990) described the appearance of lightning in mystical visions of the sephiroth as follows:

This is taken from the verse, “And the Chayot [living creatures], running and returning, like the appearance of lightning (*bazak*, רבזק)” (Ezekiel I: 14). The word *Bazak*, which is found only in this one place in the Bible, is usually translated as “lightning” or “a spark.” According to other interpretations, *Bazak* denoted a flashing meteor or a bursting bubble. According to all these opinions, the *Sefer Yetzirah* is stating that the Sefirot can only be visualized for an instant, and then they vanish.

Wilhelm/Baynes (1967) calls this trigram Sun (Chinese term, not the Sun as a star), the gentle, penetrating wind, wood.

In his *Shih Yi*, Crowley (1971) puts the trigram in Hod on the TL. It is the inverse of the trigram in Chesed.

Crowley (1971) assigns this trigram to Air (△), suggesting the atmosphere below the unbreakable abyss of Heaven. He assigns the letter R to this trigram and says:

Continuous vibration, like L but active (Air or Æthyr.)

R and L are both considered semi-vowels. It is a comment only on the sound.

☱, 232, **Tiphareth, Sun,** ☉

And in soft light.

The lines of this trigram are symmetrical vertically. It is assigned to Middle Pillar Tiphareth on the TL and QT.

One thinks of the Sun, the center of our Solar System, as a bright light. Compared to the lightning of Kether, the light of the Sun is steadier and appears less violent. The comparison is to being struck by lightning rather than being sunburned.

Wilhelm/Baynes (1967) lists this as clinging, light giving fire. This certainly describes the Sun as the center of the Solar System. The related hexagram, Li, has the same name.

Crowley (1971) assigns this trigram to the Sun in the position of Tiphareth. He (1996) assigns the letter Q to this trigram and says:

Combines K and U. (The Sun.)

Again, this is a description of the sounds, and possibly nothing more.

☵, 322, Netzach, ▽ Water

Then were the waters gathered together from the heaven,

The symbolism is **water** as rain from heaven. The description matches the *I Ching*. Trigram ☵, 322, is the opposite is fire ☲, 332 in Netzach.

The sephira seems out of order for reasons described above. It is the third father, has two Yang lines, and faces Da'ath.

The trigrams for Fire and Water are interchanged in their position compared to positions on the TL and QT. The switch is part evidence that "The full knowledge of the interpretation of this book is concealed from all."

Wilhelm/Baynes (1967) lists this trigram as Tui, the joyous, joyful, lake. It would relate to water. It is located in the southeast in the Fo Hsu arrangement. The related hexagram is Tui.

Crowley (1971) says that this trigram, Tui, suggests a wave upon the unbreakable abyss of the sea floor. His assignment is to Chesed. He relates the letter V to this trigram and says:

Conscious male will. Manhood, strength, truth,
righteousness immortality, integrity. (Water.).

Crowley's description much better fits Geburah, Mars and fire. The Hebrew equivalent of V is Vau (ו), rod-shaped and phallic. The long list of characteristics implies maleness, appropriate to Geburah. Apparently, Crowley was not aware of the 3-d sequence of the trigrams switched Geburah and Netzach. When arranged in a 2-d numerical sequence, Geburah and Netzach switch positions reciprocally. His confusion is understandable.

Three trigrams include two Yin lines, characteristic of the Lower Triad. The sequence is Earth, Moon, Water, as the single Yang line progresses from bottom to top. (Bear in mind, however, the blind involving fire and water described above.) The sequence, instead, is Netzach (Water, ▽), Hod (Earth, ▽), and the equilibrating Yesod (Moon, ♁).

☲, 233, Geburah, Core of flame, Fire, △

And a crust of earth concealed the core of flame.

This text describes a fiery trigram. The Yang line at the top symbolizes the **crust of earth**. The lower Yin lines symbolize a pair of **flames**. It is the inverse of the trigram for Geburah, to which it is associated as a blind.

Wilhelm/Baynes (1967) calls this Ken, and relates it to keeping still, resting, and mountain Ken is in the northwest in the primal arrangement.

Crowley (1971) says this trigram reminds us of earth upon the **molten core**. He assigns it to Netzach. His commentary relates it to earth. His explanation for trigram ☲, 322 fits better here.

Crowley (1996) assigns the letter K to this trigram and says:

Opening as if startled. (Earth.)

This is the third reference to K. The others combine it with S.

☷, 323, Yesod, Moon, ∩

Around the globe gathered the wide air.

The symmetrical lines from top to bottom, with Yin at the top, put this trigram on the Middle Pillar and below Tiphareth, the position of Yesod, the Moon.

The **wide air** relates to the illusion of the Moon revolving around the earth. It is independent of the motion of planets and fixed stars.

Wilhelm/Baynes (1967) calls this K'an, mountain. In the Fo Hsu arrangement it is found in the west (Autumn). The double trigram forms the hexagram of The Abyssal (water).

Crowley (1971) calls this Khan, the Moon, and puts it in Yesod. Crowley (1996) assigns the letter D to this trigram and says:

The paternal vibration. (The Moon)

The reason for assigning the letter D is probably the shape during phases of the Moon. The footnote says: The moon is not considered a light, but cohesive with the earth's atmosphere. Its light is illusion, reflected.

☵, 332, Hod, fires upon the Earth, ▽

And men began to light fires upon the earth

The **light fires** could refer to the fire (and knowledge) brought by Prometheus, and spread by man. That suggests the elements of Air or Spirit. Assigning Hod to Earth (▽) presents a problem. By eliminating the other elements, **Earth** remains. The TL and QT traditionally assign Mercury here, the element Air.

Wilhelm/Baynes (1967) calls this Chen, the double combination, the hexagram, the Arousing (Shock, Thunder), inciting movement, thunder.

Crowley (1996) assigns the letter U to this trigram and says:

Like 0 with added refinement and a tinge of melancholy.
0 is completely self-confident. (Fire.)

Can this be interpreted as intellect (≈ fire) coming to man on Earth?

World of Assiah

In the Cube of Space model, Assiah is the Cube of One. On the QT it is Malkuth, the most receptive. It forms the manifest three-dimensional world in which we live. If there is any place on the TL QT or Cube that man knows where he is, it is here.

Looking out from Malkuth (the center eye) to the sephiroth of the Lower Triad one sees a triangle! The combined symbol is the eye in the triangle. The six sephiroth appear as a Holy Hexagram on the QT. If Malkuth is included at the center, it is like the symbol in Ararita.

☷, 333, Malkuth, Star of Glory, ☆

**Therefore was the end of it sorrow;
yet in that sorrow a sixfold star of glory
whereby they might see to return
unto the stainless Abode;
yea, unto the Stainless Abode.**

This is the last trigram. It is on the Central Axis at the Lower Triad on the QT. It interpenetrates the sephiroth of the Lower Triad and Da'ath on the Central Axis.

Each of the three Yin lines is broken (☷). The six units can easily be rearranged into the form of a **sixfold star**, ☆, symbolizing the element of Spirit, the hexagram in many rituals. In the middle of this star is a void, the Stainless Abode (? = The Nothing) in Atziluth, the place of return, or the Ain, אֵין.

Wilhelm/Baynes (1967) assigns this trigram to Kun. The related hexagram, Kun is the Receptive, devoted, yielding, earth. It is found in the north, or winter, in the primal arrangement.

Crowley (1971) calls this Kwan, Yoni, earth (as opposed to Heaven). He makes no distinction between his interpretation and the *I Ching* in its earth or receptive nature. Crowley (1996) does not assign a letter to this trigram, but he says: (Vulva).

The process becomes circular. Here, Kether is in Malkuth. Malkuth is not a dead end. It is a process of continuous change and emanation. Malkuth contains light from the Third Series. The Direct Light from Kether becomes the Returning Light from Malkuth. The QT expresses activity. It is dynamic.

The 27 trigrams are one more than 26 English letters. One trigram must have no letter (or possibly an obsolete one), or another letter is implied. Crowley gives no answer. The Hebrew alphabet is attributed to the paths, rather than the sephiroth, on the TL. It is logical to assume that this would be true for the English alphabet also. The exploration continues with the paths.

CHAPTER FOUR — LIBER XXXI VEL AL THE MYSTERY OF THE LETTERS

THE Mystery of the Letters occurs in each of the three chapters of *The Book of the Law*—the Glyph in Chapter I, the Riddle in Chapter II, and the Line and Circle Squared in Chapter III. The manuscript facsimiles are consistent. The difference between *Liber L* (manuscript without the grid) and *Liber XXXI* (with the grid) is irrelevant. The *Liber CCXX* typeset text shows distortion from translation. The relevant manuscript facsimile for each discussion is shown below.

CHAPTER ONE — THE GLYPH

I wrote me under my stars. Love is the
law, love under will. No let the fools
mistake love; for there we love and live.
There is the dove and there is the serpent:
choose ye well! He, my prophet, hath

18

chosen, having the law of the Goddess
and the great mystery of the House of God
All these old letters of my Book are
any but; but *S* is not the star. This
also is secret: my prophet shall reveal
it to Menise.

Liber XXXI Ch. 1, p. 17-18 (the Manuscript facsimile), (*Liber CCXX I*: 57)

Invoke me under my stars.

Liber XXXI I: 57 starts with the invocation of Nuit, personification of the sky. Chapter II: 1 - 4 describes her as non-manifest, the complement of Hadit. She is circumference of the sphere (the Universe) with Had at the center. From the viewpoint of Had, the only dimension is separation—but seeking union.

The invoking individual perceives himself at the center of his Universe. Metaphorically he personifies Had. The outer limit of his Universe is the sphere of Nuit that is everywhere and nowhere. She is his background of stars. His invocation brings about alignment and union with Her, and his dissolution. Go outside the box, into the Universe. Expand consciousness.

Love is the law, love under will.

Love is a universal force toward union. It begins at the Creation of the World, with the formulas: 0 (Nothing) = 1 , $0 = 1 = 2$, and $0 = 1 = 2 = \infty$ (All).

Liber XXXI I: 29-30 says:

For I am divided
for love's sake, for the chance of union.
This is the creation of the world, that
the pain of division is as nothing, and
the joy of dissolution all.

To know anything requires contrast, such as: God and Universe, Macrocosm and Microcosm, dark and light, and male and female. It is a way of saying LA (⌘) = AL (⌘), or Nothing equals God. It is the root of symmetry and balance, equilibrium. And that is the basis of the work.

Abrahamadabra is a key formula for Thelema. It matches the opposites and brings them into union. Love is the law, love under will.

The Dove and the Serpent. Choose ye well!

Here, the Dove is the symbol of spirit and baptism. In the previous æon, it symbolized the descent of the Spirit. Thelemites often associate this with a Holy Guardian Angel. They symbolize the difference in approach—water and fire.

The dove was the signal that the Deluge was receding. It is a symbol of baptism and the descent of the spirit.

The Serpent is associated with fire, the Messiah, Hebrew *Messiah*, משיח = 358. It has many connotations, especially in the previous æon. The Serpent is Nechesh, נחש = 358, the one that initiated Eve. The connotation is not evil, but one of enlightenment and initiation.

He, my prophet, hath chosen

We know Crowley's choice as prophet. He accepted responsibility as the prophet of the Æon of the Child. He used the name Baphomet as X° in the O.T.O., and The Beast, To Mega Therion, 666, as Prophet of the New Æon. He chose the enlightening Serpent.

The Law of the Fortress

The Fortress is the Tower before it is lightning struck. Metaphorically, it is tradition, history or nature. The Law says even that which stands strong will ultimately fall. It is Yin/Yang, ☯, expressed in words. Within every situation is the seed of its own destruction. The Mystery of the Letters explores this formula.

The message of The Tower is annihilation, the necessary precursor to creation. It is equivalent to the separation for the chance of union. Among the symbols on the Thoth card are: the Eye of Shiva (or Horus), the Dove and the Serpent, and Lightning (another early name for this *atu*). As a phallic symbol, it spews seed, pictured as yods on some earlier tarot decks.

An illusion can be considered reality for thousands of years. For example, the heliocentric theory of Copernicus (1543) replaced the illusory earth-centered model of Ptolemy (2nd Century C.E.). With increased understanding of Nature comes deeper appreciation of reality. The older must be destroyed and be replaced by the newer.

The great Mystery of the House of God

The House of God is an earlier title for Atu XVI The Tower. The letter Peh (פ) has a value of 80. *Liber XXXI* I: 46 connects it to 8, and 418. The 8 = Atu VII The Chariot. the Cup of Babalon. It is Cheth (ח), the eighth letter of the Hebrew alphabet, 418 when spelled in full.

God, the Voice from the Silence, created the Universe with words. The House of God is His creation, His Universe. The Mystery is the meaning and relationship of the Words to Creation and Nature. The numbers and words (Hebrew alphabet) are symbols for communicating the secrets of that Mystery, hence qabalah.

Study the Word, the Voice from the Silence and the letters of the alphabet. God created the Universe by them. The path of the Star, immediately following, shows the early light emerging from the darkness.

All these old letters of my Book are aright:

The old letters refer to the Hebrew alphabet. At least, this was Crowley's interpretation, since he interpreted a Tzaddi in the second part of the sentence.

The original Hebrew alphabet had 22 letters—Aleph (א) to Tau (ט). After the Babylonian Captivity, the alphabet included the 22 old Hebrew letters plus five final letterforms. The alphabetical sequence traces back to tradition in the *Zohar*. Beginning with the letter Tau, each came before the Creator to propose that it be first in the Torah. Beth succeeded. Aleph withdrew. The letters are also numbers (alphanumeric) with traditional correlations.

The statement in *Liber XXXI* I: page 18 recognizes this:

all these old letters of my book are aright.

In the *Sepher Yetzirah*, Hebrew letters have additional attributions. These included elements, planets and zodiacal constellations. The elements and zodiac attributions are consistent. Several classic qabalists have proposed variations in the planetary assignments. The assignment in the table follows *Liber 777* (1909).

	1	2	3	4	5	6	7	8	9
1	א	ב	ג	ד	ה	ו	ז	ח	ט
	△	♀	☾	♀	♈	♉	II	♊	♋
10	י	כ	ל	מ	נ	ס	ע	פ	צ
	♍	♎	♏	▽	♐	♑	♒	♓	♈
100	ק	ר	ש	ת	ך	ם	ן	ף	ץ
	ח	⊙	△	ה					

The Tarot Trump

Crowley interpreted the Star as Tarot trump, Atu XVII, in Liber 78 and 777.

The Marseilles sequence for the Tarot atus goes back to the 18th Century. The numerical assignment to the images is still a standard reference for tarot decks. It uses Roman numerals to note the sequence. The Fool had no number, but was placed first. The italicized names in the right-hand column below are those substituted by Crowley in his Thoth tarot deck. They differ slightly from those in *The Book of Thoth*.

-	Le Mat	The Fool
-I	Le Bataleur	The Juggler, <i>The Magus</i>
-II	La Popesse	The Popess, <i>The High Priestess</i>
-III	La Imperatrice	The Empress
-IV	Le Imperateur	The Emperor
-V	Le Pape	The Pope, <i>The Hierophant</i>
-VI	L'Amoureux	The Lovers
-VII	Le Chariot	The Chariot
-VIII	La Justice	Justice, <i>Adjustment</i>
-VIII	Le Hermite	The Hermit
-X	Le Roue de Fortune	Wheel of Fortune
-XI	La Force	Strength
-XII	Le Pendu, La Prudence	The Hanged Man
-XIII	Le Mort	Death
-XIII	La Temperance	Temperance, <i>Art</i>
-XV	Le Diable	The Devil
-XVI	La Maison Dieu	The House of God, <i>The Tower</i>
-XVII	L'Etoile	The Star
-XVIII	La Lune	The Moon
-XVIII	Le Soleil	The Sun
-XX	Le Judgement	The Last Judgment, <i>The Aeon</i>
-XXI	La Monde	The Earth, <i>The Universe</i>

In the following discussion, the non-numbered Fool is at the beginning. Positions of Justice and Strength, and the Emperor and the Star vary. The remaining trump sequence is constant.

The Glyph

The typeset version, *Liber CCXX*, Chapter I, verse 57 says: “but ♁ is not the Star.”

Crowley struggled with this verse. After he died, Symonds and Grant (1974) first published text of *The Extenuation of the Book of the Law* (1926) in their *Magical and Philosophical Commentaries*. Shortly after, Regardie (1975) edited and published the *Extenuation* as *The Law is for All*. The first printing of Regardie’s book included a facsimile of the manuscript as published in *Equinox* I (7). Subsequent printings are different. They quote from the New Comment to verse 1: 57 as follows:

The ‘old comment’ covers the rest of this verse sufficiently for the present purpose.

I see no harm in revealing the mystery of Tzaddi to “the wise,” others will hardly understand my explanations. Tzaddi is the letter of the Star, the Trump XVII. Aquarius and Aries are therefore counter-changed, revolving on the pivot of Pisces, just as the Trumps VIII and XI, Leo and Libra, do about Virgo. This last revelation makes our Tarot attributions sublimely, perfectly symmetrical.

An enlarged scan of the Glyph, shown below, is from the first edition of *The Equinox of the Gods* (1936), *Liber XXXI*, page 18. This *original in the writing of the Beast* deserves careful observation. The term *Glyph* specifically refers to the symbol as it appears on line 4 of the manuscript.



An analysis of the Glyph follows:

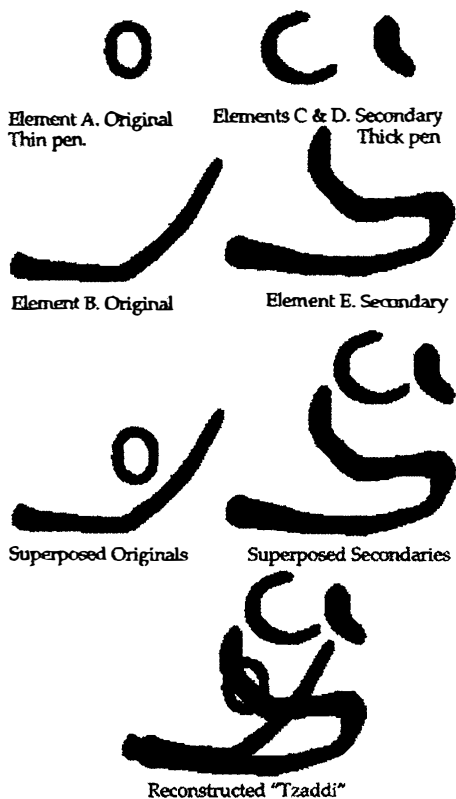

The analysis shows the significance of *the chance shape of the letters* from Chapter III: 47 was disregarded. No study using only the typeset version, *Liber CCXX*, reveals the problem. In *The Equinox of the Gods*, Crowley discusses changes made to the manuscript, but omits comments about the Glyph.

The thin circle and the lower right quarter arc are original. They look like the sun in the arms of the moon. The Glyph is a product of two different pens. The thin pen stokes underlie the thick ones. The thin strokes match the handwriting in most of the manuscript. The elements in thicker pen are later additions. (The pen appears to be the same as the one used by Rose Kelly to make other changes on the manuscript.) The additions make the Glyph more like Tzaddi. They must have been added before 1912.



A second aspect of the interpretation of the Glyph relates to the part of the sentence following the colon, with the apparent contradiction.

but is not the Star

By interpreting the Star, as he does, Crowley incorporates the tarot trump into the verse and with the Hebrew alphabet. Levi (1856) established an occult significance for the Tarot trump by connecting them to the Hebrew alphabet.

Crowley, interpreting the Glyph as a Tzaddi, resolved his paradox by switching Heh and Tzaddi. However, his action is logically unsupportable for a closed set. The Hebrew alphabet is an “aright,” closed set of 22 letters in definite order. By making the reciprocal switch of Heh and Tzaddi, Crowley “corrected” the Star (though Tzaddi had been stated as aright). The Emperor (implied and traditionally Heh) changed from its aright attribution, now became not aright. Crowley had produced reciprocal errors.

Consider changes in the closed set of 22 “old” Hebrew letters. Presumably, this does not include the new final letterforms, added later.





1. Given: *All these old letters of my book are aright* is a closed set of Hebrew letters.
2. Given: “but  is not the Star.” The statement under examination. In abstract terms, A is not B.
3. Let A represent .
4. Let B represent the Star. (The Star card pictures a woman, pouring water over herself. (See *Liber VII vel Lapidis Lazuli* V: 5.)

If the Glyph, , is a Tzaddi (צ) (Crowley’s assumption in the closed set):

5. Then Tzaddi is not the Star. (By substitution in the statement.)
6. Then Tzaddi is some other Atu. (Crowley concluded that Tzaddi was The Emperor. So, he transposed the Heh, and attributed to the Emperor, and the Star with Tzaddi.)
7. Two aright letters were reciprocally changed. (A reciprocal error within the closed set)
8. Crowley retained the Marseilles Atu numbering system for the cards. He connected them to the assignments on the paths of the Tree of

Life. (The Marseilles number is probably irrelevant.)

If the  is not a Tzaddi:

9. Then, Tzaddi can be the Star and follow the traditional attributions.
10.  cannot be Heh or any other member of the closed set of letters, since they are all aright.
11.  cannot be attributed to the Star or any other member of the set of Tarot trump attributed to the Hebrew letters.
12.  cannot be attributed to any previously recognized path on the Tree of Life.
13. Therefore, the Glyph, , must be outside the closed original aright set of letters and their attributions.

Think outside the box! If the Glyph is outside the original set of Hebrew letters or its attributes, what is it?

This also is secret: my prophet shall reveal it to the wise.

From the Old Comment in *Equinox* I (7), Crowley clearly interpreted this line as applying to himself. As prophet of the Æon, this is understandable. There is much in *Liber XXXI* he was told he would not know. One must know a secret to reveal its explanation, not just be aware of its existence.

A clue to interpretation is the word *wise*. Wisdom requires the application of knowledge and understanding. Crowley was aware there was a secret at the time, but did not know the explanation. Therefore, it might apply to Crowley, later, when wiser, but the statement is moot. Therefore, *my prophet* might mean Aiwass or another wise individual.

CHAPTER TWO — THE RIDDLE

75 Aye! listen to the numbers & the words:
 76 4638 ABK 24 ALGMOR 3Y
 x 24 89 RPSTOVAL. What
 meaneth this, o prophet? Thou knowest
 not, wouldest thou know ever. There
 cometh one to follow thee: he shall

This is translated into a typescript version as *Liber CCXX II: 75, 76*.

75. Aye! Listen to the numbers & the words:
 76. 4 6 3 8 A B K 2 4 A L G M O R 3 Y
 X 24 89 R P S T O V A L.

Every typescript version is an interpretation of the manuscript. Here, the parentheses are left out above and below 24 and 89. The differences among the 4's and the A's are not distinguishable. No spacing, or grouping letters into *words* is indicated. Consider the subtleties.

Aye! Listen to the numbers + the words:

The word *Listen* is a signal, indicating that the sounds of the letters and the words deserve attention.

The left edge of *Liber XXXI III: 76* has a slope different from the margins in the rest of the page (and of the manuscript). It emphasizes the separation from the previous part of the verse.

The Riddle is a linear sequence of numbers and letters that are grouped into words. The Riddle is comparable to a mathematical formula, a sequence of variables (letters) and constants (numbers).

4 6 3 8 ABK 24 ALG MOR 3 YX (24) (89) RPST OV AL

The Riddle lists the Paths on the 3-d Quantum Tree (QT) Tree in order. This Tree has a greater complement of paths than the traditional 2-d TL.

Watson and Crick (1953) described the double helix structure of DNA, the genetic code, the *molecule of life*. Their paper was about one page long. The explanation is simple—two helices connect by ladder-like cross connections. The process for duplication was evident immediately. Almost 60 years later, biologists are still uncovering its ramifications and significance. Life is complex. The problem is applying the explanation to biological reality. The analogy to the Riddle is close.

On the TL, and especially the QT, **each path connects two sephiroth**. Each path on the TL and the QT connects the same sephiroth, except for A'in. Additional paths became evident on the QT. The paths connecting peripheral sephiroth on the QT are all the same length.

The sequence of Riddle diagrams begins in Lower Phase. They follow the chance shape and position [sequence] to one another.

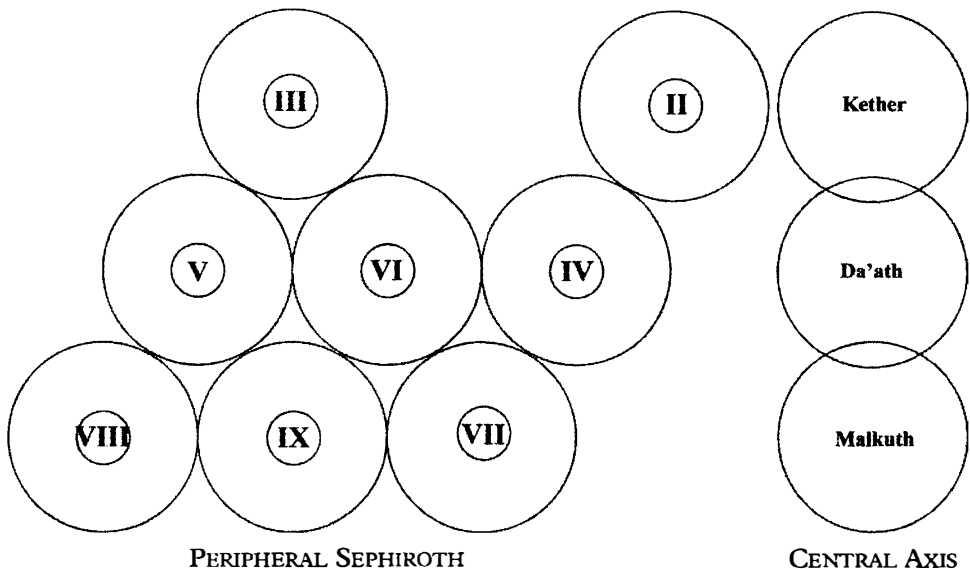

4 – The Path of Daleth – 7 Anchor of the Upper Triad

4, Daleth (ד), Venus (♀) Atu III. The Empress.

Why start with Daleth? It is always present. It anchors the Upper Triad. It shows that the Riddle begins with the QT in Lower Phase. When Tiphareth is in Upper Phase, it eclipses Daleth from front view.

The path of Daleth connects Chokmah and Binah on the TL and QT.

The figure shows Tiphareth center front at the Middle Triad. In this Lower Phase, Daleth is behind the BLP and Kether.

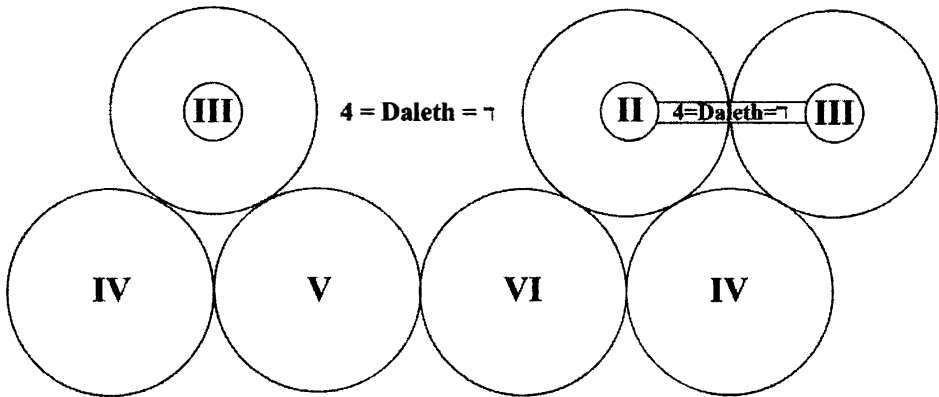

This second figure incorporates two views of the path. The long one to the left is from the front (distorted and stretched in the figure). The shorter, back view, shows the path brought forward from behind at its standard length.

6 3 8 – The Paths of Vau, Gimel and Cheth – ך, ך, and ן Lower Phase – Paths of Upper to Middle Triads

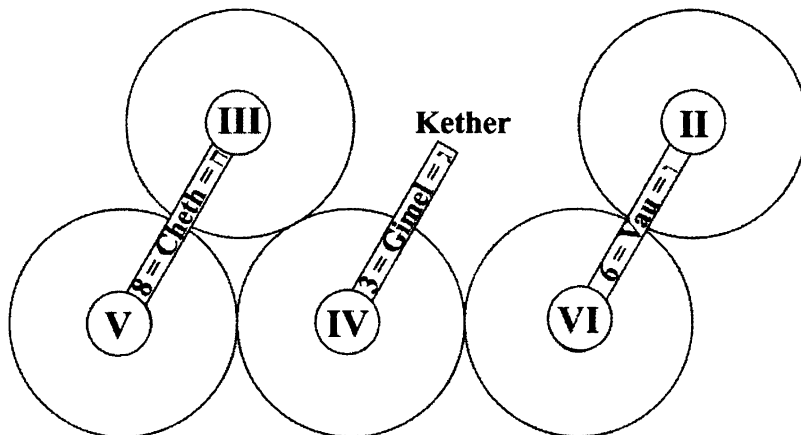

Kether is shown without a dark circumference for its central circle. Kether does not have a vessel according to *Trigrammaton*.

6, Vau (ו), Taurus (♉)

Atu V. The Hierophant or Pope.

The Path of Vau connects Chokmah to Chesed on the Pillar (or helix) of Mercy. It is the same on both the TL and QT.

3, Gimel (ג), Moon (☾)

Atu II. The High Priestess.

The Path of Gimel connects Kether to Tiphareth. This connection changes with phase. The Lower Phase position on the QT matches the TL.

In the Lower Phase, the connections would be broken if the light from Kether were restricted by a vessel. In Upper Phase, Kether and Tiphareth connect.

8, Cheth (ח), Cancer (♋)

Atu VII. The Chariot.

The Path of Cheth connects Binah to Geburah on the Pillar of Severity. It has the same position on both the TL and QT.

A B K – The Paths of Aleph, Beth and Samech – א, ב, and ס Lower Phase – Paths for Atziluth and Briah

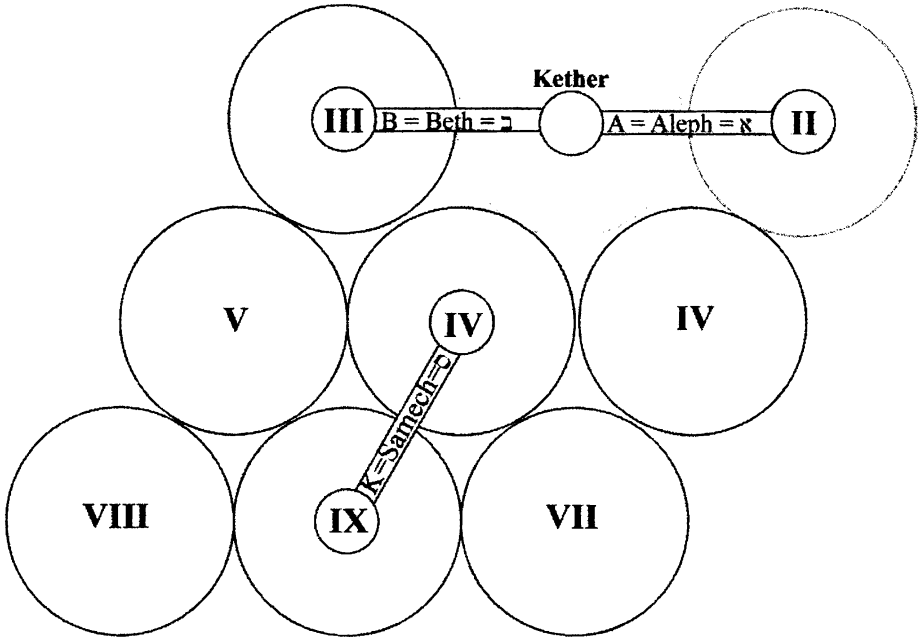

Atziluth interpenetrates Briah in the Upper Triad. Two of the sephiroth, Chesed and Geburah, are always there. Tiphareth is present there only in the QT Upper Phase.

A, the Path of Aleph (⌘ = 1), Air (△)
Atu 0. The Fool.

The Path of Aleph connects Kether to Chokmah. Kether is at the top of the Central Axis. Chokmah is at the Upper Triad on the Pillar of Mercy, in Briah. It has the same connections and position on both the TL and QT.

Historically, the position of The Fool has varied in the Tarot sequence. It has been the first card, the last card, or the penultimate card in the sequence. Attributing Tarot atus to the Hebrew letters added occult symbolism. The position of The Fool then affected the letters to which the other cards are attributed.

B, the Path of Beth (⊐ = 2), Mercury (♃)
Atu I. The Juggler, The Magus.

The Path of Beth connects Kether to Binah. It has the same connections on both the TL and QT.

K, the Path of Samech in Briah (⊔ = 60), Sagittarius (♐)
Atu XIV. Temperance, Art.

Assignment of the Path of K to Samech requires explanation. The path connects Tiphareth to Yesod on the Middle Pillar to both Briah (here) and Yetzirah (later).

The paths of Vau, Cheth and Samech connect to Kether through Chokmah, Binah and Tiphareth. They are one step from Kether, and do not connect directly to it. Samech connects only in Upper Phase.

Listen to the sound. The letter Ksi, Ξξ, in Greek is between Nu and Omicron. It sounds like [k] and [s]. Samech in Hebrew is between Nun and A'in, but has only the sound of [s]. The letter C in English has the sound of [k], [s] or its combination [ks] as X. The K in the Riddle is the [k] sound equivalent of Ksi, [ks] or Samech.

The Golden Dawn Portal Ritual (Regardie, 1971, Vol. 2, pp 191-193) describes two Tarot cards for the Atu Temperance. Whether these correlate to the two paths of Samech needs further study.

**24 – The Paths of Yod and Kaph – ך, ם
Phase Shift. The Path of Lamed first appears.**

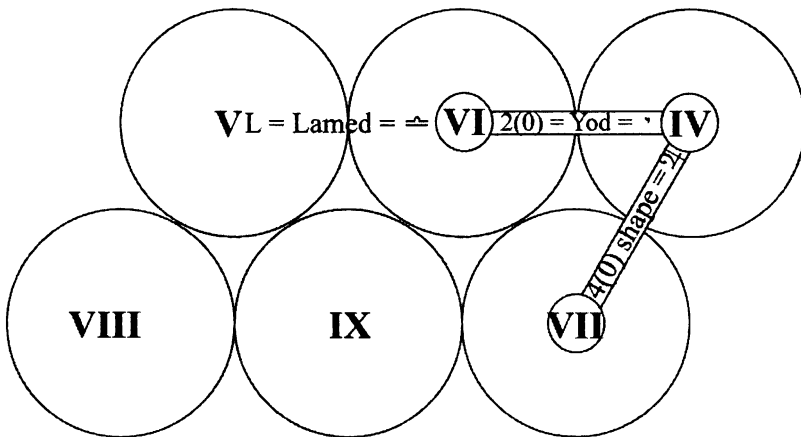

LOWER PHASE

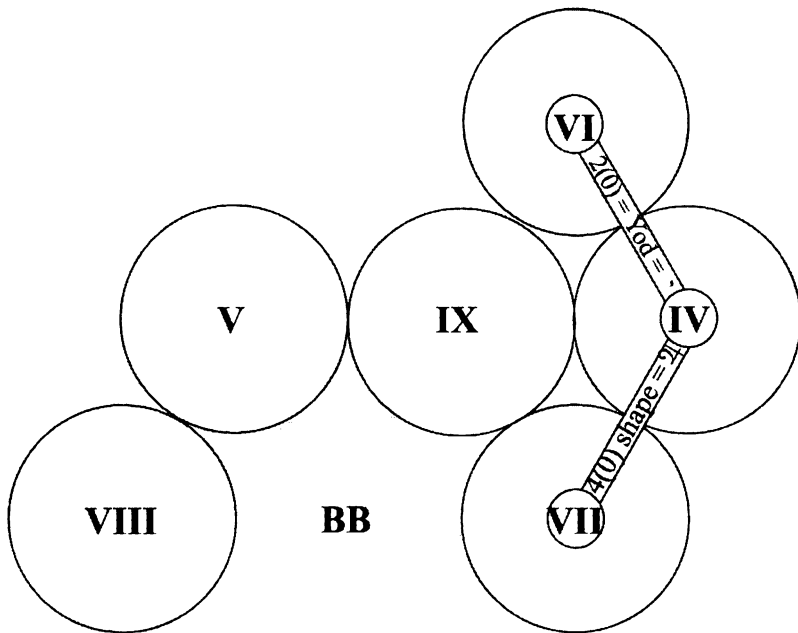

UPPER PHASE

(2, 20) The Path of Yod (י), Virgo (♍)**Atu IX. The Hermit.**

The Path of Yod connects Chesed to Tiphareth on the TL and the QT. The path moves between phases and is always present. The path is in Yetzirah, but has definite Briatic connotations as well. It is recognized as the source of all other letters. In the QT sequence, it indicates the change to Upper Phase.

The 2, for Beth, has been used already. The next available $2 = 2(0) = \text{Yod}$. The Hebrew value of Yod is 10, and Yod spelled in full is 20.

(4, 40) The Path of Kaph (כ), Jupiter (♃)**Atu X. The Wheel of Fortune.**

Kaph, 20, is attributed to the path of the Wheel of Fortune on both the TL and QT. It connects Chesed to Netzach. This path is in Yetzirah.

The number 4 was used for the initial Daleth. The numbers 2, 4, and 20 are already used. The next available is $4 = 4(0)$. Jupiter (♃) rules the Wheel of Fortune. The shape of the 4 is similar to ♃. Chance shape applies.

3, 30 The Path of Lamed (ל), Libra (♎)**Atu XI. Justice, Adjustment.**

Lamed connects Geburah to Tiphareth only in Lower Phase on the QT. The Path of Lamed does not appear in the Riddle until later. It is mentioned here because it shows in the Lower Phase figure. This may explain the Teth/Lamed blind in the historic Tarot sequence (*e.g.*, the Marseilles deck).

**A L G—Paths of A(ries ♈), L(eo ♌), and G(emini ♊)—⌒, ⌛, and ⌜
Upper Phase, Upper Triad Paths to Tiphareth
Anchor of the Middle Triad**

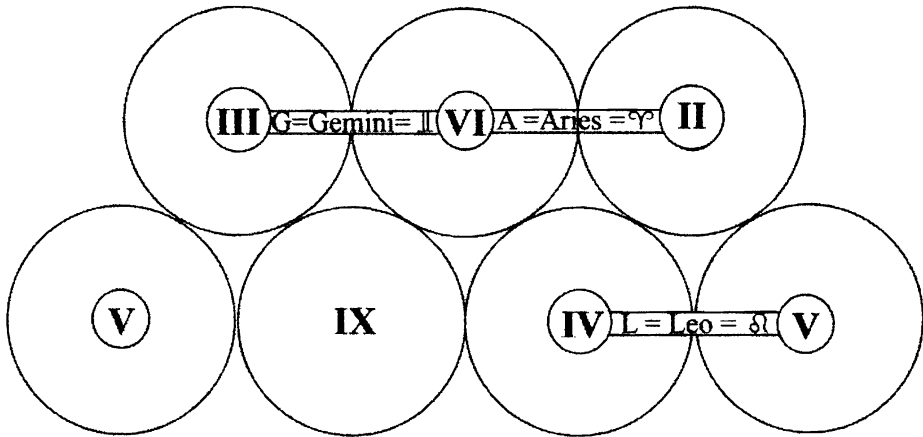

**A, The Path of Heh (⌒) = 5, Aries (♈),
Atu IV. The Emperor.**

The Path of Aries, ♈, The Emperor, occupies the path of Heh (⌒ = 5) between Chokmah and Tiphareth on both TL and in Upper Phase of the QT. Crowley discusses the path, its position on the TL and its relationship to the design of the Tarot card. He assigns the Emperor to Tzaddi for reasons discussed earlier. He writes in the last paragraph in *The Book of Thoth*, page 78 under IV The Emperor:

It is finally to be observed that the white light which descends upon him [the Emperor] indicates the position of this card on the Tree of Life. His authority is derived from Chokmah, the creative Wisdom, the Word, and is exerted upon Tiphareth, the organized man.

The Vision and the Voice, 6th Æthyr begins:

There cometh into the stone the great Angel whose name is Ave, and in him these are symbols which strive for mastery—Sulphur and the Pentagram, and they are harmonized by the Svastika.

Crowley provides the following explanation for this quotation as Note 3 at the foot of the page:

3. Sulphur is the active fiery nature, and the Pentagram is the Microcosm of the Elements. But Atu IV—the Emperor—refers to Heh (5) for the Pentagram, and he forms the symbol of Sulphur by the position of his arms and legs. The Svastika harmonizes these, being the fiery thunderbolt, the electric whirling and the balance of the four elements (with its four arms) in a Microcosm.

The Mercuric Sigil for Heh in *Liber CCXXXI* shows the pentagram with five elements.

The sequence in the Riddle and tradition also support his original assignment of The Emperor to Heh (𐤇 = 5). This parallels the Golden Dawn TL understanding at the time, and *Libers 78* and *777*.

L, The Path of Leo (♌), Teth (𐤇) = 9 Atu VIII. Strength. (= Thoth Tarot Atu XI, Lust).

The Path of Teth is the anchor of the Middle Triad. It connects Chesed to Geburah. The Tarot card variously shows a woman opening the mouth of a lion. The attribution is to Leo. The letter Teth means serpent. The lion/serpent image occurs in the qliphothic sigil for Teth in *Liber CCXXXI*.

Crowley puts the Path of Teth on line 19 of the tables in *Liber 777* (1909). This line relates zodiacal Leo, Atu VIII Strength and 9. In *The Book of Thoth* (1944) and the Thoth Tarot deck, he associates Leo with Lust and Atu XI. His number returns to the Marseilles, (pre-Golden Dawn) blind.

The Path of Leo, ♂, Teth, 𐤇, appears for the first time in the Riddle — after that of Lamed. It is always present. From the traditional front view it is behind either Tiphareth or Yesod on the QT. Phase shift explains the Teth/Lamed sequence. Details are discussed under Lamed, below.

G, The Path of Gemini (♊), Za'in (𐤆) = 7 Atu VI. The Lovers [or: The Brothers].

The Path of Gemini connects Binah to Tiphareth. It is part of the Upper Triad. Though its position moves with the position of Tiphareth, it is always present.

Upper Triad Sephiroth and Paths

The cross-section diagram shows the three paths that interconnect Kether to the sephiroth of Briah in Upper Phase. These paths are shorter than between sephiroth.

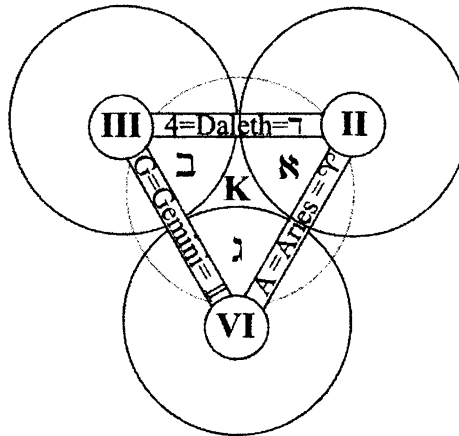

Upper Phase

UPPER PHASE, UPPER TRIAD

Home state occurs when the six peripheral sephiroth of Briah or Yetzirah are found in just two triads. This figure shows the Upper Phase of Briah. This has Tiphareth in the Upper Triad with Chokmah and Binah. Chesed, Geburah and Yesod in the Middle Triad are not included.

M O R – Paths of Mem, Samech and Peh – מ, ס, and פ Upper Phase of Yetzirah

Kaph, Mem and Samech are the three pillars connecting the Middle and Lower Triads of Yetzirah. Lower Phase is home phase for Yetzirah.

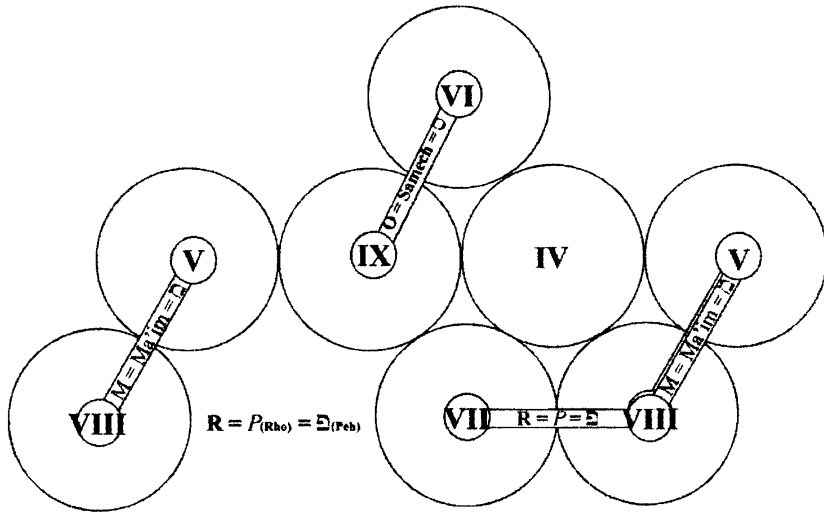

**M, The Path of Mem (מ = 40), Water (▽)
Atu XII. The Hanged Man.**

The Path of Mem connects Geburah and Hod in Yetzirah on the Pillar of Severity on both the TL and QT.

**O, The Path of Samech in Yetzirah, (ס = 60), Sagittarius (♐)
Atu XIV. Temperance, Art.**

The Path of Samech connects Tiphareth and Yesod coincidentally in the Worlds of Briah and Yetzirah. In block Hebrew, the character is rounded. Its cursive form is O. Chance shape applies here.

In the Riddle, this second occurrence of the path occurs between M = 40 and P (discussed below) = 80. The two phases, 60 + 60 = 120, make the spelling of Samech (סמך) in full. In Yetzirah, this path relates to the [s] sound of C. The two sounds, separately and in combination (as X, [ks]), are those of C in English. The sounds of [k] and [s] occur in both in the Hebrew and Greek names for the letters.

**R, The Path of Peh (פ = 80), Mars (♂)
Atu XVI. The House of God, The Tower.**

The Path of Peh connects Netzach and Hod. Like Daleth and Teth, it is definitive for the Lower Triad. Each is the first path appearing in the Riddle for its respective triad. Cheth already uses 8.

The sound of R (in Latin and English) is written as *P* (Rho) in Greek, which looks like the Latin letter P. Peh (פ = 80 in Hebrew).

The connection of 61 to 8 = Cheth, The Chariot; 80 = Peh, The House of God; and Abrahadabra and 418 is specified in *Liber XXXI*, Chapter I, page 12 (\approx *Liber CCXX I*: 46):

Nothing is a secret key of this law.
Sixty-one the Jews call it; I call it
eight, eighty, fourhundred + eighteen.

Here is another key. Frater Achad (1918) uncovered the significance of 61 (= Ain = אַיִן). The *eight, eighty, fourhundred + eighteen* were discussed earlier.

Return to Lower Phase

3 = 3(0) – The Path of Lamed – ל

**3, The Path of Lamed (ל = 30), Libra (♎)
Atu XI. Justice, Temperance, Adjustment.**

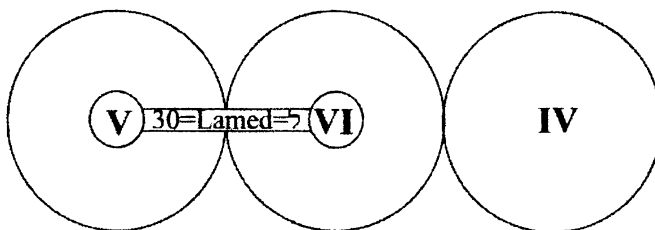

The Path of Lamed, ל, 30, connects Geburah to Tiphareth on the TL, and the QT in Lower Phase only.

The occurrence of the Path of Heh (Emperor, ♀, Sign of the Spring Equinox) alternates with that of Lamed (♁, Justice, Adjustment, Sign of the Fall Equinox). Together they show the formula of AL—A(ries, ♀) and L(ibra, ♁)—shown on the cover of the First Edition of *The Equinox*.

Crowley's tenure as a member of the Golden Dawn exposed him to Knowledge in the Practicus lecture. The data occur in Folio 35 of the CIPHER Manuscript:

Key #	Heb.	Key	Value	Symbol	Tarot Trump
(17)	ח	XI	19	♁	XIII = Strength
(18)	י	IX	20	♃	Prudence = Hermit
(19)	ל	VIII	22	♁	XI = Justice

The *Cipher Manuscript* has a large X occurring between the columns for Symbol and Tarot Trump. It juxtaposes the positions between Justice and Strength.

The key number in parenthesis is used by Crowley to correlate symbols. In *Liber 777*, Column 1, the index includes the Hebrew alphabet in lines 11 to 32. In Column II, Teth is 19; Lamed is 22. In Column VII, 19 is Leo, 22 is Libra. In Column XV, 19 is Strength, 22 is Justice. The trump titles in Column XV do not have Roman numerals assigned.

Crowley continued the sequence in *The Book of Thoth* (1944) and the Thoth Tarot deck as:

Tarot	Description	Heb.	Zodiac
VIII	Adjustment	ל	♁
XI	Lust	ח	♁

Crowley uses this sequence as part of the defense for the interpretation of the Glyph as Tzaddi. The diagram on page 11 of *The Book of Thoth* (1944) shows his interpretation.

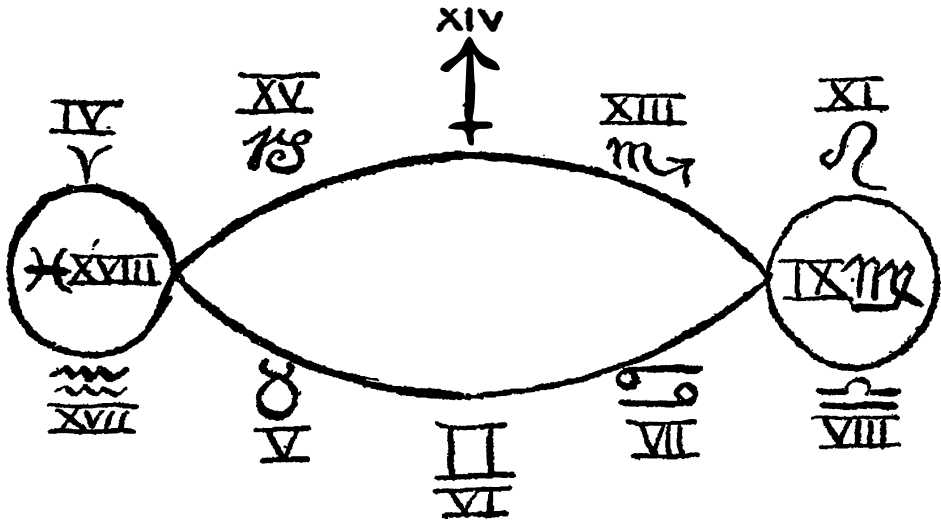

Diagram The Double Loop in the Zodiac

This diagram shows the Teth/Lamed situation of the Marseilles deck. However, the designs for these trumps do not match the zodiacal attributions to the Hebrew letters. Wescott (1970) wrote that Levi was aware of the sequence, but did not publish it. Crowley was definitely aware of the situation. He published the corrected sequence in *Liber 777* and 78.

Decker and Dummett (2002) explain the current situation as follows:

Originally, trumps VIII (Justice) and XI (Strength) were interchanged merely for the purpose of assigning Hebrew letter and other correspondences to them; when Mathers designed a pack for the Order's members to copy, the two cards were actually renumbered XI and VIII respectively. This numbering, unknown in traditional Tarot packs intended for play, is to be found in many esoteric and cartomantic packs intended for play, though not in all. Even when Hebrew letters are absent, it is a sure mark of adherence to the tradition, not of Papus, but of the Golden Dawn.

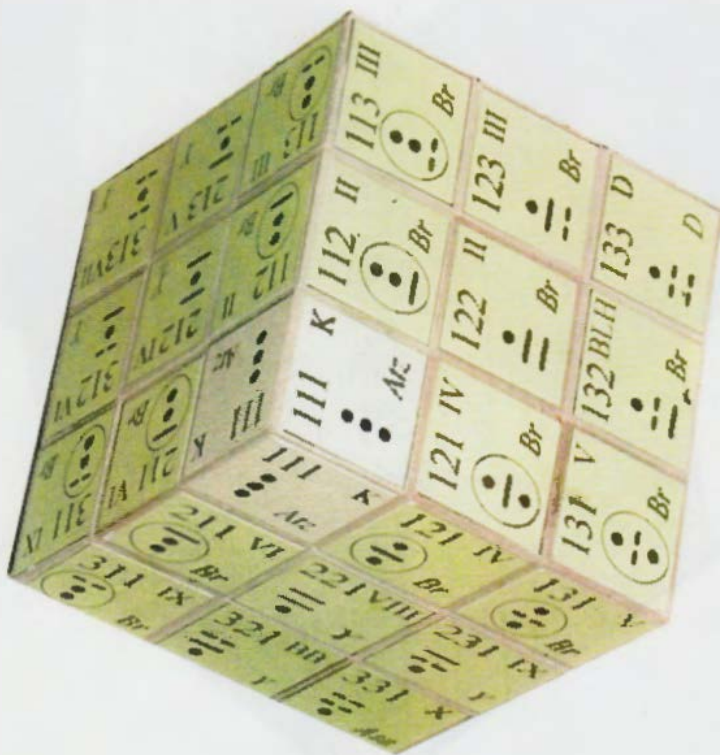

Figure 1. The Cube of Three viewed from above.

Center is 111, Kether, from which radiate the three edge pairs, the vessels of Briah. The three blocks of four represent the Lights from Kether that illuminate the vessels of the sephiroth.



Figure 2. The Cube of Three viewed from below.

The hollow inner space locates the position of the Abyss. From inside, the lights from Kether can be seen.

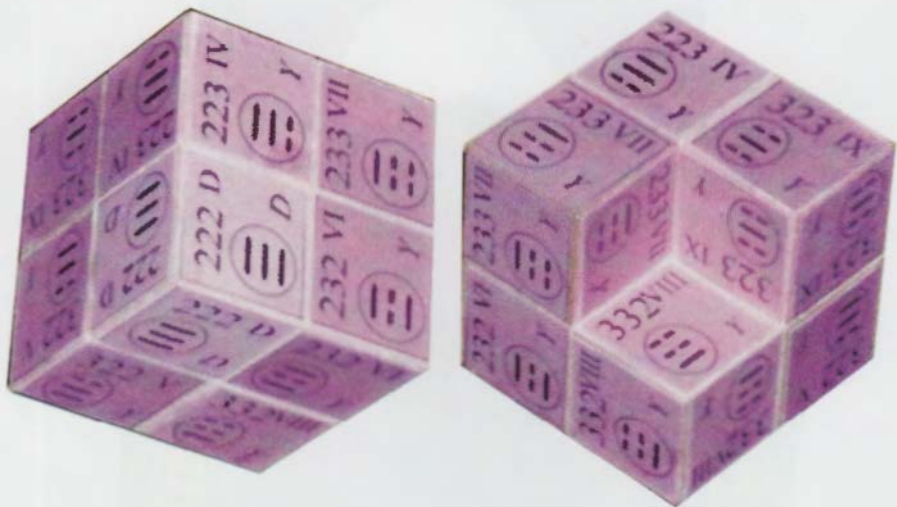

Figure 3. The Cube of Two viewed from above and below.

The vessels of Yetzirah and Da'ath. The latter shows the volume occupied by the Cube of One. The space between represents the Veil of Paroketh.



Figure 4. The Cube of One, comprising Malkuth and Assiah.

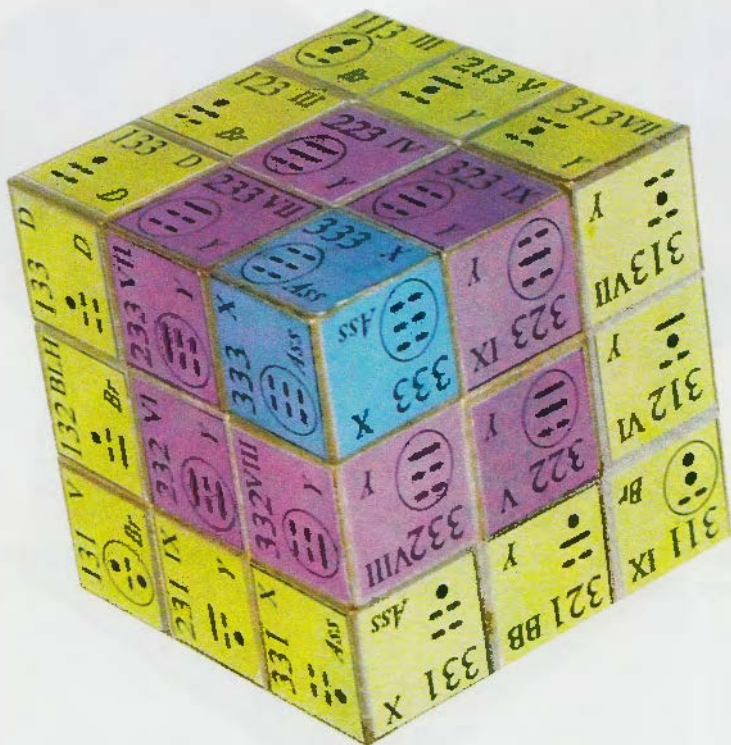

Figure 5. The Cube of Three from below.

Showing the nesting component Cubes of Two and One.



Figure 6. The 3-d Quantum Tree of Life, non-helical form.

The triads are deflected slightly downward. The sephiroth appear in the same positions as in the 2-d Tree of Life.



Figure 7. The 3-d Quantum Tree of Life in Lower Phase.

The Peripheral Sephiroth surround the Central Axis. Tiphareth is in the Middle Triad. The light gray sphere in the upper right represents the Brothers of the Left-hand Path (see Trigrammaton).

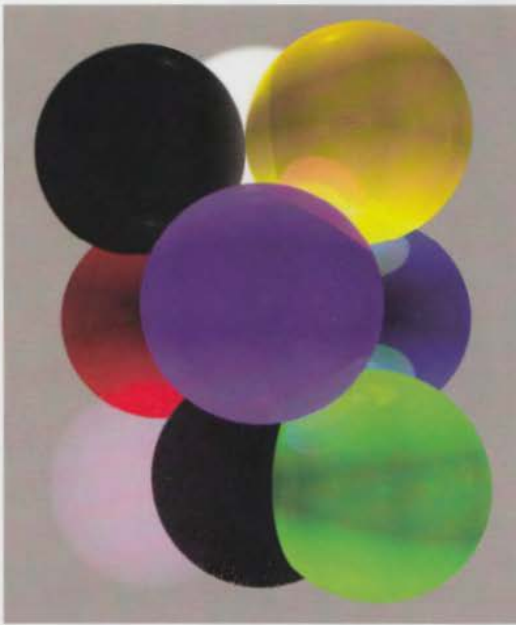

Figure 8. The 3-d Quantum Tree of Life in Upper Phase.

The Peripheral Sephiroth surround the Central Axis. Tiphareth is in the Upper Triad. The light gray sphere in the lower left represents the Black Brothers (see Trigrammaton).

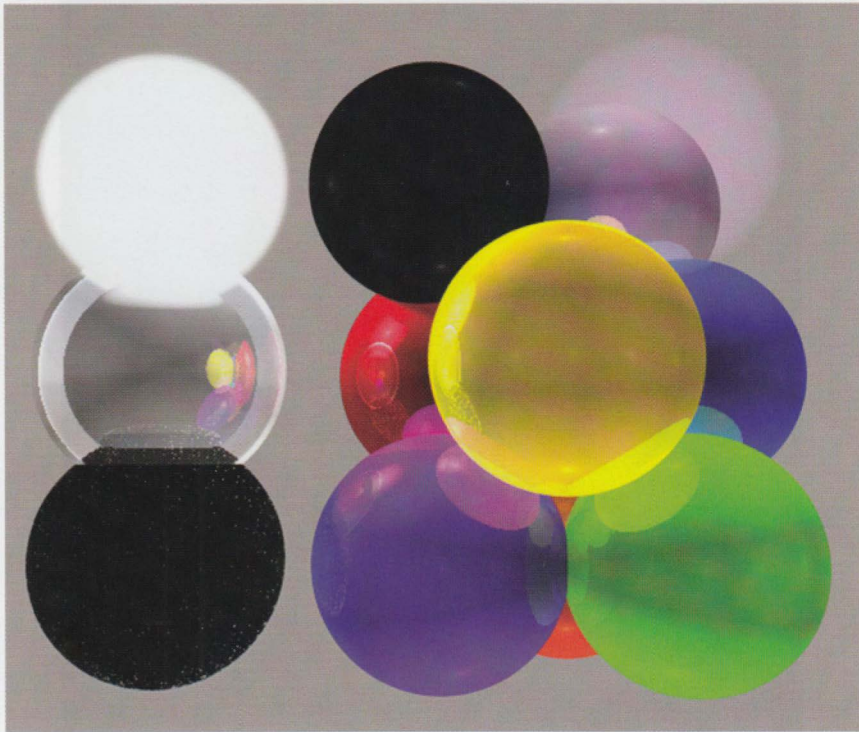

Figure 9. The components of the 3-d Quantum Tree of Life.

To the left is the extracted Central Axis. To the right are the Peripheral Sephiroth. Each triad has sephiroth in level position.

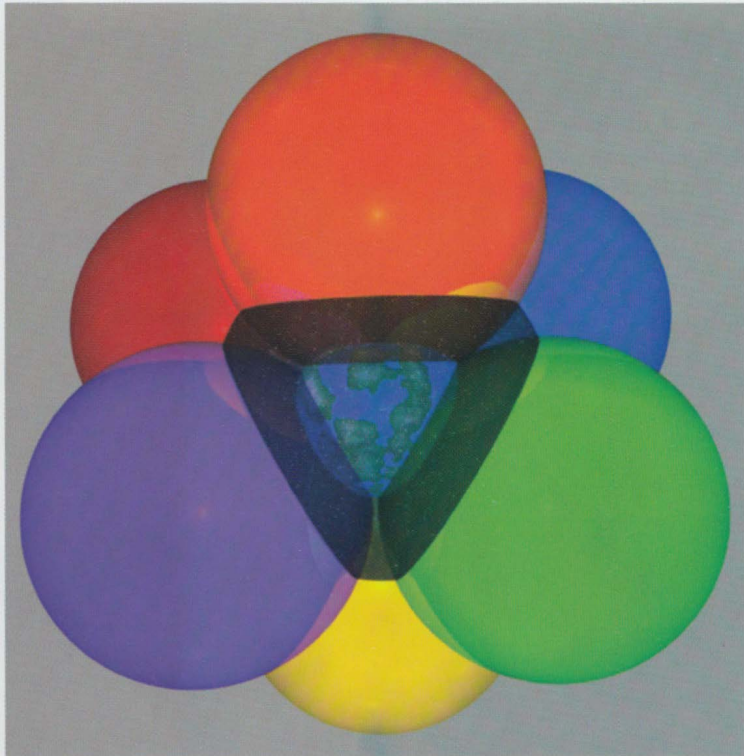
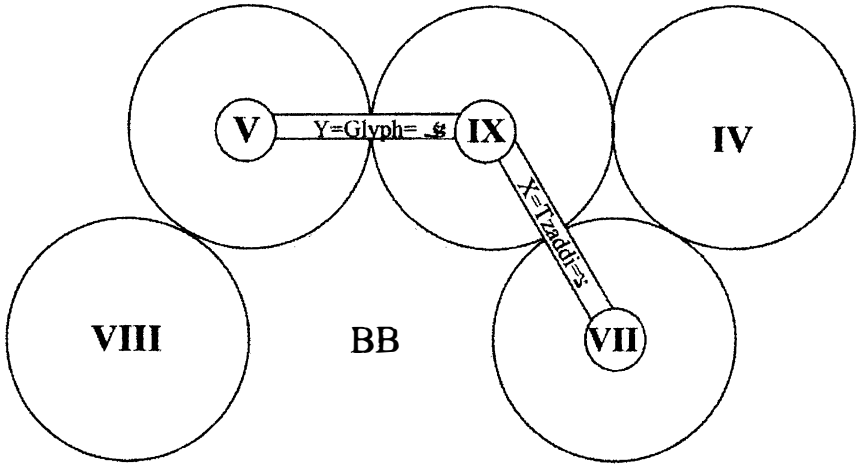

Figure 10. The 3-d Quantum Tree of Life viewed from Malkuth.

The Lower and Middle Triads sephiroth assume the arrangement of the Holy Hexagram. Malkuth is at the center. It produces a symbol similar to the Ararita formula.

**Y X – Paths of Glyph, \mathfrak{S} , and Tzaddi, ζ .
The Paths of 90**



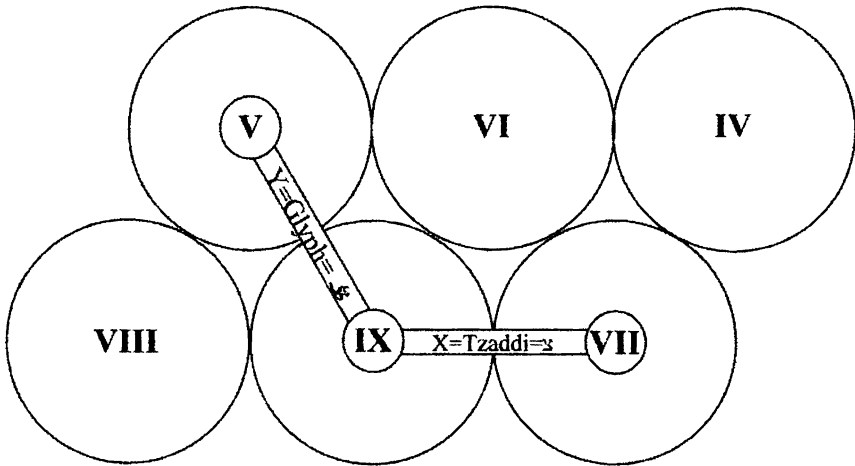

LOWER PHASE



UPPER PHASE

The Path of the Glyph (= 90), The Serpent Atu Unassigned. (? Serpens/Ophiuchus).

The Path of the Glyph, , connects Geburah to Yesod. It occurs in both Upper and Lower Phases of the QT. It is not seen on the TL (though it may be eclipsed behind the Paths of Lamed (= 30) + Samech (= 60). Its numerical value, 90, is established by its position as a counterpillar (*q.v.*, below). On the QT, it completes the tri-radial symmetry among them.

The path is a complement of Tzaddi. Both connect to Yesod. As Yesod moves in phase shift on the QT, the Glyph and Tzaddi are synchronized. The non-moving end of the Path of the Glyph, , the Serpent, is at Geburah, a male energy related to Mars (♂). The non-moving end of the Path of Tzaddi, , The Star, is at Netzach, the female energy of Venus (♀). They unite at Yesod. Abrahadabra. With the Glyph equal to 90, the counterpillars have a numeric total 210 (= 50 + 70 + 90). In *Liber 777 Sepher Sephiroth*, under the number 210 is found: γ : ν : ζ , the formula NOX.

On the Thoth Atu XXI The Universe, the central figure has a foot on the head of the Serpent. The Serpent brings knowledge of good and evil, as in *Genesis*. The Serpent, Messiaich (משיח, The Messiah) and The Serpent that initiated Eve, Nechesh (נחש) each have a numerical value of 358.

Liber XXXI, Chapter II, verse 26 adds;

I am the secret Serpent coiled about to
spring: in my coiling there is joy. If I
lift up my head, I and my Nuit are one.
If I droop down mine head, and shoot
forth venom, then is rapture of the earth,
and I and the earth are one.

On its annual astronomical course, the sun, passes through 13 constellations. The one omitted in the zodiacal sequence is Ophiuchus, the Serpent Bearer. He holds the Serpent. Serpens and Ophiuchus are now considered as separate constellations. Additionally, Serpens is the only constellation with two separate parts. Serpens projects beyond the body of Ophiuchus as

a Head and a Tail, *Caput et Cauda Serpentes*. The ecliptic crosses *Cauda*. The Path of the Glyph, , may be attributed to the Path of the (Tail of the) Serpent. It lies between Scorpio (♏, ♀) and Sagittarius (♐, ♂). It has a value 90. Teth (𐤛 = 9) is the Hebrew letter for Serpent.

X, The Path of Tzaddi (צ = 90), Aquarius (♒)

Atu XVII. The Star.

The Path of Tzaddi connects Netzach to Yesod. It occurs on both the TL and QT. Its position changes with phase. Its shifting synchronizes with the path of the Glyph at Yesod. The Class A *Liber VII*, Chapter 5, verse 5 refers it to the letter Tzaddi, and Atu XVII The Star card image:

Only one fishhook [Tzaddi] can draw me out; it is a woman kneeling by the bank of the stream. It is she that pours the bright dew over herself, and into the sand so that the river gushes forth.

Liber XXXI, Ch. I, page 17 (verse 56):

All words are
Sacred and all prophets true; save only that
they understand a little; solve the first
half of the equation, leave the second
unattacked. But thou has all in the
clear light, and some though not all in the
dark.

Does this statement concerning the solution for an equation apply to the equation about the Glyph that follows next? If so, it is the interpretation of the Glyph, not The Star, that is critical. If so, then the original lines could have the suggested reading: “Do not confuse  [Glyph] with Tzaddi.”

(24) (89) Middle Triad Paths from Da'ath

In *Liber XXXI*, two pairs of numbers in the Riddle have distinctive parentheses above and below. The parentheses are absent from all typeset versions

of *Liber CCXX*. (Perhaps their presence should be indicated by regular parentheses at least.) This is still another reason why the holographic manuscript facsimile must be available for study in all publications of *The Book of the Law*.

Along with the Glyph, the horizontal parentheses, above and below, are new symbols related to the Mystery of the Letters. *Liber XXXI II: 55* alludes to this possibility:

Thou shalt obtain the order + value of
the English Alphabet; thou shalt find
new symbols to attribute them unto.

See the following chapter.

Liber Trigrammaton has one vessel and one light for Da'ath. A path from Da'ath goes to each of the pillars.

In the *Liber XXXI* Riddle, the numbers and parentheses designate paths from Da'ath. The numbers connect to Middle Triad sephiroth on the Pillars of Mercy and Severity respectively. The parentheses designate the path to the Middle Pillar. The double nature of the Path of Samech in Bria and Yetzirah has a shared connection from Da'ath. The (2 4) paths connect to sephiroth in Bria. The (8 9) paths connect to sephiroth in Yetzirah. These previously unrecognized paths match new letters—the Hebrew final letter-forms. A cross-section of the QT at the Middle Triad for Bria and Yetzirah shows how Da'ath occupies the Central Axis position and interpenetrates the peripheral sephiroth.

(24) Da'ath Paths to Briah

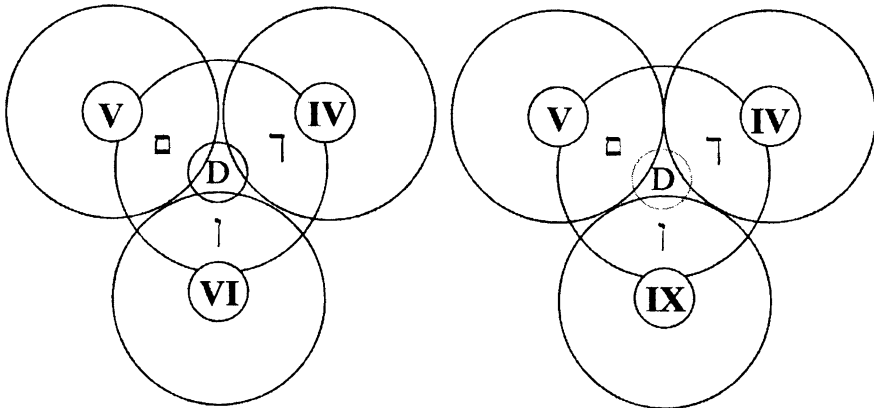

Lower Phase

Upper Phase

4 = 40 = ◻

6 = 60 = ◻ No Samech final →

2 = 20 = ◻

600 = Ma'im final = ◻

700 = Nun final = ⌒

500 = Kaph final = ⌒

Geburah via Cheth to Binah

⌒ Tiphareth via Samech to Yesod (Lower)

⌒ Chesed via Vau to Chokmah

⌒ Yesod via Samech to Tiphareth (Upper)

Lower Phase Briah

Upper Phase Briah

Tiphareth at Middle Triad

Yesod at Middle Triad

2, Kaph final, ⌒, Information, 500.

The Path of 2 (= 20) connecting Da'ath to Chesed in Briah is the Path of Kaph final, ⌒. Chesed then connects to Chokmah (Sephira II). The sequence of the "old letters" ends with Tau (⌒ = 400). Alphanumerically, the next letter is Kaph final = 500.

The proposed subject/title, **Information**, derives from the nature of Chokmah and Kaph (= 2 = 20 = ◻), the Wheel of Fortune (♁), and the cyclical nature of the Scientific Method (*q. v.*, Peh final, below). The data needed to support a scientific hypothesis derives from Chaos (Chokmah). The data are collected and organized using the Scientific Method. They uncover natural laws and theories.

4, Mem final, ם, Revelation, 600

The Path of Mem (ם = 40) connects Geburah to Hod. The path connecting Da'ath to Geburah in Briah is Mem final, ם. The value of Mem final is 600.

The proposed subject/title, **Revelation**, derives from the nature of symbolic water (ם = 40), Binah and contemplation, inward thought and mystical practice. As investigation is objective, so meditation is subjective. It is the complement to Kaph final.

⤴, Upper Parenthesis, part of Nun final, ן, Inspiration, 700.

This aspect of the Path of Nun final, ן, connects Da'ath to Tiphareth in Lower Phase. The value of Nun final is 700.

Each of the parentheses has value of 700 because each connects through the Middle Pillar, Middle Triad position of the QT. Four different sephiroth, with different vessels according to *Trigrammaton*, occupy this position—Tiphareth or Yesod in combination with Upper or Lower Phase. The light from Da'ath that interpenetrates these four is the same. Da'ath connects to the four parentheses through Nun final (ן = 700). The energy within Samech travels in either direction.

Inspiration in science can be recognized when the scientist, based on a set of observations, envisions a different question or viewpoint to explain it. In essence, it symbolizes the proposition of a new thesis.

⤵, Lower Parenthesis, part of Nun final, ן, Aspiration, 700.

This aspect of the Path of Nun final, ן, connects Da'ath to Yesod on the Middle Pillar in Upper Phase. The value of Nun final is 700.

This Lower Parenthesis path from Da'ath is called **Aspiration**. It is the will of the Magician, flowing upward to Tiphareth in the Upper Triad.

This illustrates the nature of the Crossing of the Abyss, which has an above and a below component—spiritual and manifest, internal and external, inductive and deductive, subjective and objective. Ambition may be another way to express it.

Aspiration is the motivation to achieve higher levels of initiation.

(89) Da'ath Paths to Yetzirah

In the cross-section diagram, the connections between the peripheral sephiroth at the Middle Triad and Da'ath are clear. As with the paths to Kether in the Upper Triad, these connections are shorter than the ones between peripheral sephiroth.

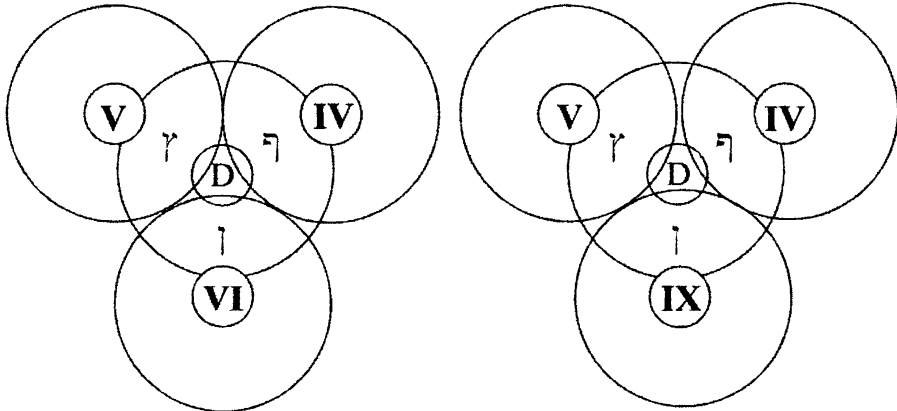

Lower Phase

Upper Phase

9 = 90 = Tzaddi = ט

5 = Nun = נ

8 = 80 = Peh = פ

900 = Tzaddi final = ף

700 = Nun final = ן

800 = Peh final = ף

Da'ath via ף to Geburah

Da'ath via ן to Tiphareth

Da'ath via ף to Chesed

Geburah via Glyph to Yesod

— Tiphareth via Nun to Netzach (Lower)

Chesed via Ayin to Hod

— Yesod via Samech to Tiphareth (Upper)

LOWER PHASE YETZIRAH

UPPER PHASE YETZIRAH

TIPHARETH AT MIDDLE TRIAD

YESOD AT MIDDLE TRIAD

These figures appear identical if the Briah/Yetzirah designation is omitted. It explains in part the position of the Abyss in the standard TL?

The paths from Da'ath to Yetzirah are like those in Briah. Yetzirah is below the Abyss, and the paths have more manifest expression.

8, Peh final, ף, Science, 800.

The Path of 8 (פ = 80 = Peh) connects Da'ath to Chesed in Yetzirah. It is the Path of Peh final, ף. Chesed connects to Hod (Sephira VIII) through the counterpillar Path of A'in. The value of Peh final is 800.

Hod is the sephira of reason and rationality. It complements the emotion and sensitivity of Netzach. The parallel to the Path of Information, above, suggests **Science** as a suitable subject/title. The approach to understanding is objective and deductive.

9, Tzaddi final, ך, Religion, 900

The Path of Tzaddi final connects Da'ath to Geburah in Yetzirah. It is the Path of Tzaddi final, ך, 900. Geburah then connects to Yesod, Sephira IX, via the counterpillar path of the Glyph (𐤆, 90). The numeric value of Tzaddi final is 900.

Yesod (Sephira IX) represents foundation. The parallel to the Path of Aspiration suggests a suitable subject/title for this path to be **Religion**. It is the complement to Science, represented by Peh final. Its approach to understanding is subjective and inductive.

⤿, Nun final, ן, Conversation, 700

The Path of the Upper Parenthesis connects Da'ath to Tiphareth in Yetzirah in Lower Phase. In Thelemic understanding, this path may be considered as Knowledge and Conversation with a Holy Guardian Angel. The Central Axis end is Da'ath, knowledge. The peripheral end is Tiphareth. The concept also associates with beauty and harmony.

The reference in Hebrew qabalah to the name of the god form for Tiphareth in Assiah, *i.e.*, Eloah v Da'ath, יהוה אלוה ודעת, IHVH Eloah and Da'ath, supports this.

Keats' (1820) "*Ode on a Grecian Urn*" ends with:

Beauty is truth, truth beauty, — that is all
Ye know on earth, and all ye need to know.

This attributes beauty and symmetry to Nature. The concept of symmetry has been key to the understanding of sub-atomic structure. It is the expression of the $0 = 1$ and $0 = 1 = 2$ formulas of the Universe in formation.

Conversation with a Holy Guardian Angel is a landmark in initiation. It occurs among the sephiroth of the Middle Triad. It ends when the Adept departs from Exempt status, crosses the Abyss, and enters the City of the Pyramids, Binah in the Upper Triad.

Note the connection to Nun, Atu XIII Death. That path occurs only in Lower Phase. In the more spiritual Upper Phase, death is not present. The path is broken.

⤵, Nun final, ך, Questioning, 700

This Lower Parenthesis path connects Da'ath to Yesod in Yetzirah in Upper Phase. The Path of Samech then connects from Yesod on the Middle Triad to Tiphareth in the Upper Triad.

This last of four aspects connects the Path from Da'ath (ך, Nun final) to the Middle Pillar to Yetzirah in Upper Phase. The foundation of the material aspect of initiation is Questioning.

Da'ath Connections to the Peripheral Sephiroth The Final Hebrew Letter Forms Summarized

Lateral View

The figure below shows a lateral view with BriaH and Yetzirah, each in home phase. BriaH is in Upper Phase; Yetzirah is in Lower Phase. The six sephiroth of BriaH (above the Abyss) and the six of Yetzirah (below the Abyss) illustrate the principle *As above, so below*. BriaH has fewer path connections, and is more flexible and creative. Yetzirah has counterpillar paths, and is more stable and Formative. There has to be a contrast to recognize their difference. Da'ath is shown behind the sephiroth in each helix. This is an artifact from using a flattened cylinder projection.

Only five Da'ath connections to the peripheral sephiroth are required. They match the new final letters of the Hebrew alphabet: ך, ם, ן, ף, and ץ.

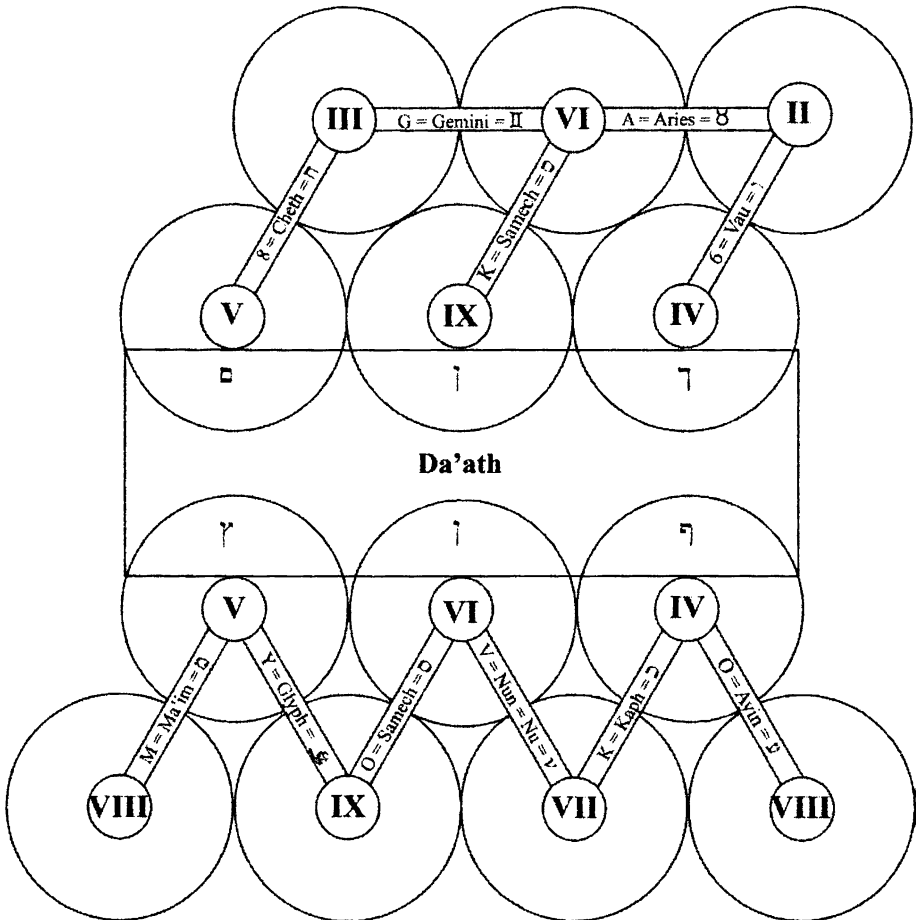

Da'ath is a single Central Axis sephira. The diagram above shows that it is behind each of the peripheral sephiroth in the Middle Triad.

R – Final Path in Phase Shift Lower Phase

After Paths from Da'ath, the Riddle continues with peripheral sephiroth in Lower Phase of Yetzirah.

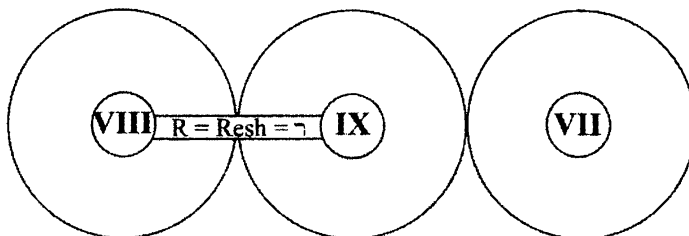
R, The Path of Resh (ר = 200)**Atu XIX. The Sun, ☉.**

The Path of Resh connects Hod to Yesod on the TL, but only in Lower Phase of the QT.

Phase shift reflects the illusion of Day and Night. The light can also represent the light of Initiation, the exoteric Sun giving energy to life. The dark is the esoteric origin. At the highest level, it parallels the states of Ain (= Nothing, Dark) and Kether (Light). At another level, it may represent Hoor-Paar-Kraat and Ra-Hoor-Khuit as Heru-Ra-Ha.

And God said (*Genesis I: 3*):

Let there be light.

P S T – Yetzirah Connections to Assiah
Lower Phase

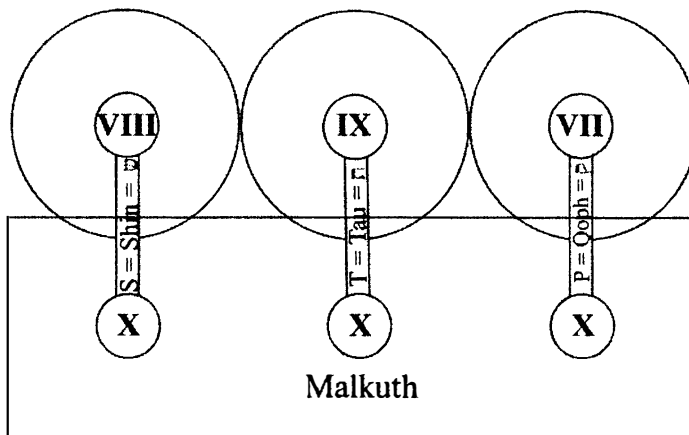

The sephira Malkuth is at the Lower Triad of the Central Axis. Like Da'ath, it is central among the peripheral sephiroth of that Triad.

On the TL, these three paths connect the Lower Triad sephiroth to Malkuth (World of Assiah). Malkuth is displaced downward because the TL treats sephiroth as mutually exclusive. The paths form the familiar rainbow, QST, seen in the *Liber CCXXXI* Mercuric Sigil for Samech. On the QT, Malkuth (World of Assiah) is at the same level as the Lower Triad, since sephiroth in different worlds interpenetrate. The paths between worlds lead inward to join the Central Axis.

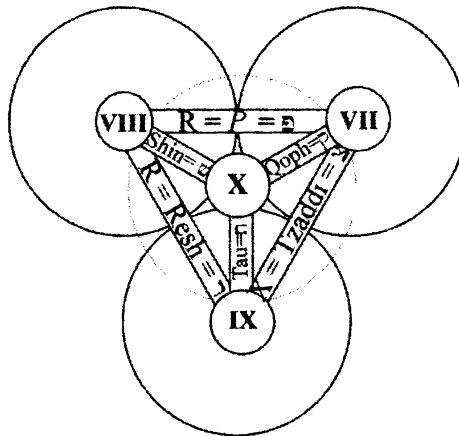

Lower Phase

Cross-section of Lower Triad, Lower Phase

P, The Path of Qoph (פ = 100) **Atu XVIII. The Moon, Pisces (♆).**

The Path of P or Qoph (פ = 100) connects Netzach to Malkuth. The Path of Peh (פ, 80) already uses the English letter P. This is a different path. Tzaddi (צ) is 90. The next available number is Qoph (פ, 100). It also has the characteristic of having the same chance shape of the letter as P. The arrangement of the letters in the Riddle requires some interpretation to maintain the distinction of the paths. Refer to the table in Appendix I and the chart in Chapter VI.

S, The Path of Shin (ש = 300)**Atu XX. The Last Judgment, The Æon, Fire (△).**

The Path of Shin (ש = 300) connects Hod to Malkuth. It is a well-recognized attribution for fire (△), and the 3-d Pyramid in the Mercuric Sigil for Shin of *Liber CCXXXI*. The pyramid is one symbol for initiation and connects to rituals in *Liber 671* and to Adonai (אדני = 65) in *Liber LXV*.

In the Thoth Tarot deck, Crowley changed the name of Atu XX from The Last Judgment to The Æon. A difference in the concept of time is apparent. The Last Judgment projected an end of earthly existence. The New Æon is open, unlimited and promising. This change of paradigm is symbolic for the Æon of the Child.

T, The Path of Tau (ט = 400)**Atu XXI. The World, The Universe, Saturn (♄).**

The Path of Tau (ט = 400) connects Yesod and Malkuth. It is the final old letter. The Qliphothic Sigil for Tau in *Liber CCXXXI* express duality. The Mercuric Sigil expresses unity. Both are tripartite.

In the Thoth Tarot deck, Crowley changed the name of Atu XXI The World to Atu XXI The Universe. By doing so, he presented a different concept of space, going from a limited World base to an infinite Universal space. The beginning of the Æon of the Child is a new signal for both religion and science. The recognition of the counterpillars on the Quantum Tree is a key revelation of The Riddle.

O V – Yetzirah, Counterpillar Connections Lower Phase

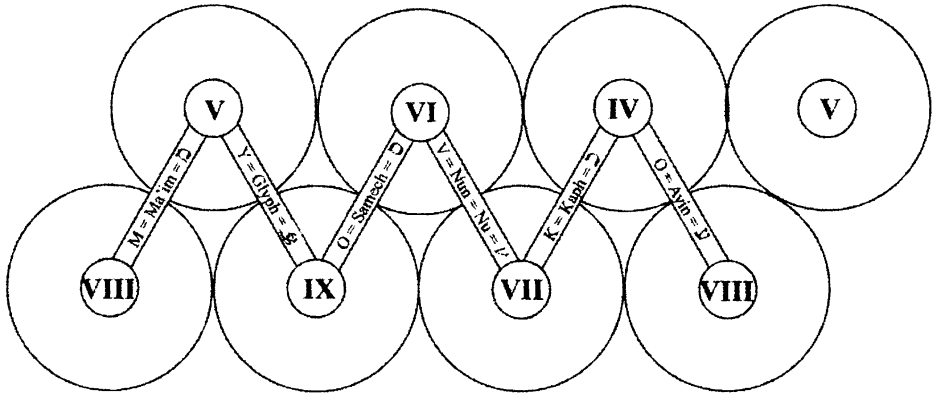

The back-slanting paths, Kaph, Mem and Samech, are the traditional pillars between the Middle and Lower Triads of Yetzirah. Their values are 20, 40 and 60 respectively, totaling 120.

The forward-slanting paths, Nun, A'in, and the Glyph, connect between pillars **and** triads. Their values, 50, 70 and 90, total 210. They are the counterpillars. They represent the paths of Death, Devil and Serpent. They also symbolize the NOX formula (210).

On the TL, only the Path of Nun is completely revealed. The Path of A'in is partly revealed. The Path of the Glyph is completely hidden. The QT and the Riddle reveal all three.

O, The Path of A'in ($\psi = 70$) Horus/Set Atu XV. The Devil, Capricorn ($\sqrt{3}$).

The Path of A'in ($\psi = 70$) connects Tiphareth to Hod on the TL. On the TL, the Path of Yod obscures the upper part of the Path of A'in. The path is half known and half concealed. This is the only path where the end sephiroth differ between the TL and QT. Is the difference explainable? Yes. If Tiphareth were at the same level as Chesed and Geburah, the concealed part of the Path of A'in would be evident. The QT shows a definite connec-

tion from Chesed to Hod.

From a Thelemic perspective, what does this new revelation about A'in mean? Atu XIII, the Path of the Devil, becomes the Path of Horus/Set. The exoteric Devil is the Goat of Mendes, Levi's Sabbatic Goat, or Baphomet, in Capricorn (♄). Crowley maintains the Goat in the design in the Thoth card. The goat has a cap of grapes, signifying reproductive force or fertility. Its horns are long serpentine helices. Both Levi and Crowley associate Baphomet with Pan and reproductive force. The helical horns suggest the spiral (= helical) force of the Universe (and the QT model).

Saturn, the ruler, is Set, the ass-headed god of the Egyptian deserts. He is the god of the south. The name refers to all gods containing these consonants, such as Shaitan or Satan. Essential to the symbolism are the surroundings—barren places, especially high places.

Crowley (1944, p. 105ff) attributes the eye in the forehead of the Goat representing upon the highest and most secret mountains of the earth, the Himalayas, to the god Pan. The averse pentagram with the head of the ass, or the head of Baphomet inscribed, is another symbol.

With the New Æon comes a new interpretation. Crowley alludes to a different, esoteric symbolism with the eye on the forehead of the goat, and the testes below. In *Liber DCLXXVI vel Pyramidos*, the candidate says, "I am blind and emasculate." The qliphothic sigil for A'in in *Liber CCXXXI* shows a blind face and dissociated male genitals. What underlies this?

The symbol of the Eye and the Testes is that of Horus-Set and their reconciliation in Egyptian myth. A detailed analysis of the myth in *Seth, God of Confusion*, Te Velde (1977) devotes a whole chapter to Seth, the enemy and friend of Horus. The strength drained is sexual, as opposed to physical strength. The point of the scorpion is the seed of Seth. He has discharged his seed into the body of Horus.

Seth is a member of the Ennead, the nine primeval Egyptian gods. Horus is his nephew, the son of Osiris. Seth is the cause of disorder. Horus, his nephew via Isis, unlike earlier generations, is not hermaphroditic, and symbolizes good and order.

Te Velde interprets the battle where Horus and Seth wound one another. The battle is the homosexual relationship initiated by Seth. Seth was not castrated but made impotent through losing his seed. Horus loses an "eye." The eye is reduced, and drips the seed. Seth abused Horus.

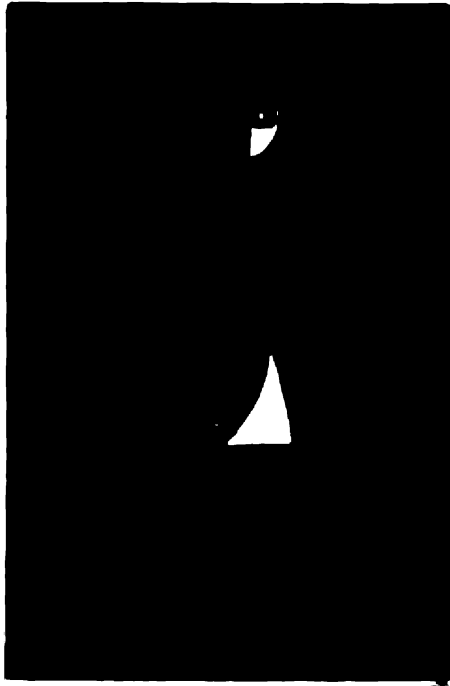

HORUS AND SET UNITED, CHURCHWARD (1910)

The value of A'in is 70. A'in applies to The Devil (Atu XV). The value of the path as Horus/Set may be interpreted also as $2 \times 70 = 140$. This would recognize Horus, the Child of the Æon. Consider the pentagram as a micro-cosmic or manifest symbol. The manifestation of RHK would be $5 \times 140 = 700$. This is the sum of the two final Crowley Tarot trumps—XX. The Æon = $\varpi = 300$ plus XXI. The Universe = $\aleph = 400$. These two changes reflect a broader understanding in the Æon of the Child.

The sound eye of Horus is a symbol of good and holy things. The Egyptian ritual of completing the eye considers Horus and Set in polar antagonism, different from an antinomian belief in God/Satan. Harmony is reached when Horus and Seth are united.

The testicles of Seth represent savagery, unbridled nature and unruly urges. It complements the eye of Horus and makes a balanced whole.

Lurker (1974) suggests evidence for the last possibility. There he describes Horus as a sky god, symbolized by the celestial falcon, and

equated with the Pharaoh. He was a manifestation of Horus (the Child). His symbol was the royal symbol of the winged disc. A quote follows:

Because of the Egyptians' dualistic world, Horus gained a rival in his uncle Seth. Horus lost an eye in the battle between them, but in the end, the two deities were reconciled in rulership over the 'land of the Nile.' Seth usually appeared as a god over Upper Egypt and Horus as a god over Lower Egypt. In later Egypt Horus was regarded as the ruler of all Egypt, whilst Seth remained god of the infertile desert...

The analogous joining of two parts of Egypt is symbolic of joining of Macrocosm and Microcosm. Seth is an earlier, original, dark, and underworld god. He also may found at the nadir, midnight opposite noon. Horus is a later god, related to dawn and initiation.

V, The Path of Nun (ⱥ = 50) **Atu XIII. Death, Scorpio (♏).**

The Path of Nun (ⱥ = 50) connects Tiphareth to Netzach on the TL, but in Yetzirah only in Lower Phase QT. In *Liber CCXX*, the typescript interprets this as the letter V, but it is the lower case Greek letter Nu (*Nu*). OV becomes ON. ON is one of the most significant formulas of Thelema, and occurs at all levels of its initiatory rites.

The Riddle connects this path to the same sephiroth as on the TL and QT. The Tarot attribution is Atu XIII Death. The phases alternate death and non-death (= life). In Upper Phase, there is only life.

In the Riddle, the 700 for Nun final is absent. It occurs as the parentheses above and below (signifying alternation) the 24 and 89 for 500/600 and 800/900. The upper terminus of Nun (= 50, Nun final, ⱥ = 700) is at Tiphareth—a signal for the position of Nun final. The Path of Nun final (ⱥ = 700) is the path from Da'ath to the Middle Pillar at the Middle Triad.

Y, The Path of Glyph,

This path connects Geburah to Yesod (*q. v.*, above). This is the third complementary counterpillar path. Following the pattern of the pillars (Ɽ = 20, Ɽ =

40, and $\text{v} = 60$, total 120), the counterpillars are $\text{l} = 50$, $\text{v} = 70$ and $\text{S} = 90$, total 210. It was described earlier.

The counterpillar paths together form the NOX formula. The Glyph ($\text{S} = \text{Y}$) substitutes for Tzaddi ($\text{Z} = \text{X}$).

On Atu XXI The Universe, the central androgyne has a foot on the head of the serpent. The eye of Shiva is above, like the Wheel of Fate. Could it be that the Universe and the Æon cards represent Space/Time? Thus a revelation about the New Æon. This agrees with the Force/Fire of Teth/Shin represented in the LASH TAL formula.

AL – The Central Axis Return to Kether

The Central Axis is independent of phase. It includes direct connection between Assiah and Atziluth, or Malkuth and Kether. It is the path of returning light.

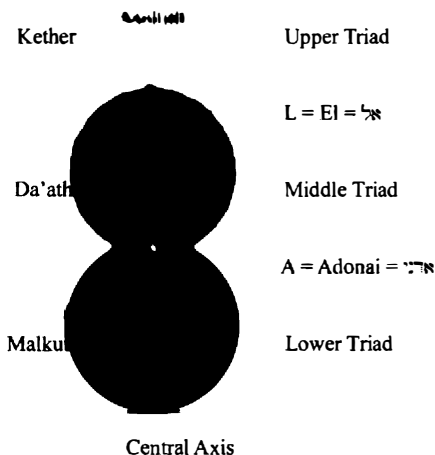

A, The Path of Adonai ($\aleph = 1000$), $\aleph\text{דנ} = 56$

The Path of A is for Adonai. It connects the Worlds of Assiah and Da'ath on the Lower and Middle Triads, respectively. The A is larger than its surrounding letters in *Liber XXXI*, suggesting a value of 1000. Previous 1's include Aleph, $\aleph = 1$; Kaph, $\text{כ} = 10$, and Qoph, $\text{ק} = 100$.

The symbol of the Central Axis supports Section 24 of *Liber 194, An Intimation with Reference to the Constitution of the Order O.T.O.*

The Supreme and Most Holy King is appointed by the O.H.O. His is the ultimate responsibility for all within his holy kingdom. The succession to the high office of O. H. O. is decided in a matter not here to be declared: But this you may learn, O Brother Magician, that he may be chosen even from the grade of a Minerval. And herein lieth a most sacred Mystery.

Malkuth is in Kether, but in a distinctive manner. The path is through knowledge.

L. The Path of L (𐌌 = 30).

This letter and value are the original title for *The Book of the Law*.

The Creator God, in Atziluth finishes the Riddle. “30” is a traditional way to end a news article. Together with the path of A, the Central Axis becomes AL, 𐌌𐌐, = 31, It is a key formula of Thelema. The path connects Da’ath to Kether on the Middle and Upper Triads of the Central Axis. It completes the return to Kether in Atziluth.

Historically, the distinction between Kether and the Ain, 𐌐𐌌, is not always clear. However, AL should not to be confused with the Demiurge in Chesed. The Riddle ends with three great formulas of Thelema in the Æon of the Child—NOX, ON, and AL.

Thirty-two Paths of Wisdom

The 32 Paths of Wisdom are based on the *Sepher Yetzirah* I: 1. Kaplan (1990) expands on this in his Appendix I. The Key column of *Liber 777* derives from it.

In contrast to the traditional definition of paths applied to the TL, paths on the QT are only connections between sephiroth. They are not the sephiroth that terminate or anchor individual paths. Each path is distinct and has a unique combination of sephiroth at its ends.

Paths Atziluth to BriaH	3 Paths
BriaH Home Paths in Upper Triad	3 paths
BriaH Paths btw Upper and Middle Triad	3 paths
Paths BriaH to Da'ath	3 paths
Paths Da'ath to Yetzirah	3 paths
Yetzirah Paths of Middle Triad	3 paths
Yetzirah Paths btw Middle and Lower Triad	3 paths
Counterpillar paths, Middle to Lower Triad	3 paths
Yetzirah Home Paths in Lower Triad	3 paths
Paths Yetzirah to Assiah	3 paths
Paths on Central Axis	2 paths
Total number of paths	32 paths

The correlation of these 32 paths to those listed in *Liber 777*, column 13, needs further research.

LIBER XXXI II: 76, AFTER THE RIDDLE

After the Riddle, the text of *Liber XXXI* continues on page II: 21:

What
meaneth this, o prophet? Thou knowest
not, nor shalt thou know ever. There
cometh one to follow thee: he shall
expound it. But remember, o chosen
one, to be me; to follow the love of
Nu in the star-lit heaven; to look forth
upon men, to tell them this glad word.

The words, *o prophet*, seem to address Crowley as scribe during the dictation of *Liber XXXI*. He was told that he would not know the answer to the Riddle. He wrote down the original text faithfully. He did not understand it, and never tried to solve it. In his *Djeridensis Comment*, Crowley expressed his role as the prophet of the Æon.

Crowley's comments about *the one to follow thee, he shall expound it*. The first occurs in the *Old Comment* in *Equinox I* (7): 398 (1912):

A final revelation. The revealer to come is perhaps the one mentioned in I: 5 and III. 47.

Crowley's *New Comment* was not published until after his death. Symonds and Grant (1974) first published the account on page 248, relating to the Riddle, as:

The passage following appears to be a Qabalistic text (on the regular pattern) of any person who may claim to be the Magical Heir of The Beast. Be ye well assured all that the solution, when it is found, will be unquestionable. It will be marked by the most sublime simplicity, and carry immediate conviction

(The above paragraph was written previous to the communication of Charles Stansfield Jones with regard to the 'numbers and the words' which constitute the Key to the cipher of this Book. I prefer to leave my remark as it originally stood, in order to mark my attitude at the time of writing).

CHAPTER THREE – THE LINE AND CIRCLE SQUARED

Libor XXXI III: 1 – The First Verse

The first verse in the typeset *Libor CCXX* contains a consistent misinterpretation of the first word of the manuscript. It shows how errors in print or interpretation are often be perpetuated. It reminds all to **study the manuscript!** A possible qabalistic interpretation of the word in the manuscript can be found in Appendix II.

Libor AL III: 47 – The Line and the Circle Squared

Crowley's statement in the *Old Comment* refers to *Libor XXXI*, Chapter III, verse 47. This, the longest verse in *Libor XXXI*, begins on page 15, and ends on page 16 (the page with the grid). The verse starts on page 15 of the manuscript. The typeset version always omits the line and circle squared.

47. This book shall be translated into all tongues: but always with the original in the writing of the Beast; for in the chance shape of the letters and their position to one another; in these are mysteries that no Beast shall divine. Let him not seek to try: but one cometh after him whence I say not, who shall discover the key of it all. Then this line drawn is a key: then this circle squared in its failure is a key also. And Abrahadabra. It shall be his child + that strangely. Let him not seek after this for thereby alone can he fall from it.

The verse is very explicit.

First: It declares a way to protect the integrity of the message of Hoor-Paar-Kraat, through Aiwass, to Ankh-af-na-Khonsu (or Crowley) as scribe. The message needs wide distribution. The details of the message in the manuscript are protected by facsimile reproduction of the manuscript. Therefore the admonition is, **but always with the original in the writing of the Beast**. The facsimile takes precedence over all typeset versions.

Second: Details include **the chance shape of the letters and their position to one another**. For deciphering the mystery of the letters, the facsimile is critical. It provides the rationale.

Third: Crowley was told he would not understand the mysteries of the letters. Yet, he did investigate it (evidence—the grid on page 16), even though he was told twice that he would fail.

Fourth: Crowley alludes to *the one who cometh after* in his *Old Comment*. He alludes that the *New Comment* has a qabalistic solution.

Fifth: **This line drawn is a Key**. This is the largest single stroke in the entire manuscript. **It is absent from all typescript editions** of *Liber CCXX*. The line begins between the words *chance shape*, and emphasizes them. The slope reflects the direction between Geburah and Yesod. It ends near the “circle squared.” It suggests a view of the Path of the Glyph on the QT (and even on the TL, if the path had been recognized).

16
 chance shape of the letters and their
 position to me and her: on these assumptions
 that no Priest shall divine. Let him
 not seek to try: but one cometh after
 him, where I say not, who shall
 discover the key of it all. Then
 this time down is a key: then this
 circle squared \oplus in its failure is a
 key also. And Abrahamah. It shall
 be his shield & that strongly. Let him not
 seek after this, for thereby alone can he
 fall from it.

Sixth: then this circle squared in its failure is a key also. Like the omission of the line in *Liber CCXX*, the symbol for the circle squared is omitted. It could have a standard typographic symbol, \oplus , included.

The circle squared is a symbol of the union of Macrocosm and Microcosm, of $6 + 5 = 11$. Here it is near the junction of the Path of the Glyph (⚔) from Geburah (⚔), and the Path of Tzaddi from Netzach (♀). Why "in its failure"? The line does not touch the circle squared. The Y, representing the Glyph in YX is not complete, and possibly equivocal as a Y. There most likely are other reasons.

Crowley's letter of 3 July 1944 to W. B. Crow describes the Universe as a spiral (? = helix), a circle projected along a line. He writes the Rose circle and the Cross line are no longer the task. Does this suggest failure of the model of the previous Æon?

Seventh: **And Abrahadabra.** These two words stand like an exclamation point, emphasizing the previous keys, the line and the circle squared. It confirms that the Keys relate to Macrocosmic and Microcosmic union.

Eighth: **It shall be his child & that strangely.** This is still an enigma. His second warning of failure follows. It may just refer to *The Book of the Law*.

Liber AL III: 48:

48. Now the mystery of the letters is done, and
I want to go on to the holier place.

The verse is terse. The Mystery of the Letters ends here. Do not expect additional information about this. Aiwass does deliver further messages, but they are not relevant to this Mystery of the Letters.

Liber AL III: 74, 75 – Coda

The last two verses provide separate endings to the message in *Liber XXXI*.

74. There is a splendour in my name hidden
and glorious, as the sun of midnight is
ever the son.

The sephira Hod, Splendour, relates to Mercury, (♃), as messenger. The sun of midnight is Khephra in the North, and Hoor-Paar-Kraat. The verse confirms that Hoor-Paar-Kraat is the Child. With Ra-Hoor-Khuit the Child, the initiator in the East, at dawn, they become Heru-Ra-Ha, the Lord of the Æon.

75. The ending of the words is The Word
Abrahamadabra
The Book of the Law is Written
And Concealed
Aum. Ha.

The formula Abrahamadabra is key.
The three chapters of *The Book of the Law* are finished.
The secrets are included.
The end is a sigh of completion.

CHAPTER FIVE — LIBER CCXXXI — ATUS OF TAHUTI

LIBER CCXXXI, The Atus of Tahuti correlates several categories of information about the paths on the Tree of Life and the Tarot. Like *Liber Trigrammaton*, its components require individual interpretation as well. They provide depth to understanding of the path characteristics, and remind us of the advantages of exploring interrelationships. It is a Class A liber.

First, the liber correlates the letters of the Hebrew Alphabet to the Tarot Trump. The alphabet is an index to the occult nature of the paths. Eliphas Levi recognized that principle in the mid-19th Century. In *The Book of Thoth*, Crowley (1944) greatly expanded on this symbolism.

Second, it has two tables of sigils, Mercuric and Qliphothic, with one sigil for each letter. Each sigil has underlying messages for individual exploration. These two series form *Liber XXII*, the number of old letters in the Hebrew Alphabet. They show different aspects of the alphabetic paths.

These sigils, especially those on the qliphothic side, have been previously explored more than other parts of the liber. All can be invoked, scryed for meaning through astral travel, and for sigil analysis, comparing their details to other known symbols.

An invoking ritual for knowledge, to Thoth or Mercury, such as Beth-2 in Appendix V, opens the mind of the student.

Third, between the charts of sigils is a list of alphabetic pairs. The left hand column has the Hebrew letters in order. The right hand column has duplicates, and some letters missing. Whether the comparison directs the magician to compare only within each of the series, or between series is not clear. The magician should use his own imagination. This can be difficult before he has some understanding of the individual sigils and their description of initiation.

Fourth, it gives a text description for each path. This is the heart of the *Liber CCXXXI, sensu stricto*. *The Book of Thoth* text and the Tarot Trump card often reflect it.

Fifth, it lists the Mercuric and Qliphothic genii in parallel columns, relating them to the Hebrew alphabet. It only includes the paths on the Tree of Life (TL). It does not include the additional paths revealed on the Quantum Tree (QT).

The analysis of the names presumes that Hebrew or Greek linguistic roots, indicated by syllables, have underlying meaning. The Hebrew references include: Davidson (1850) *Analytical Hebrew and Chaldee Lexicon*; Gesenius/Robinson (1906) *A Hebrew and English Lexicon of the Old Testament*; d'Olivet (1921) *The Hebraic Tongue Restored*; and Yehuda /Weinstein (1961) *Ben-Yehuda's Pocket English-Hebrew, Hebrew-English Dictionary*. The Greek sources include: Liddell and Scott (1987) *An Intermediate Greek-English Lexicon*, Arndt and Gingrich (1937) *A Greek-English Lexicon of the New Testament and other Early Christian Literature* and Berry (1948) *The Classic Greek Dictionary*.

Nevertheless, the interpretations are proposed with caution.

Above the body text is the statement: "(This book is true up to the grade of Adeptus Exemptus. V.V.V.V.V. $8^\circ=3^\circ$.)" It is limited to the manifest world.

Following the pattern of the previous chapters, the organization has a linear sequence of 22 units. The titles, plus the material from *Liber CCXXXI* are included in boldface. The Mercuric sigils are to the left of the Qliphothic ones, as in that liber.

Previous Commentaries

Kenneth Grant (1977). *Nightside of Eden (Carcerorum Qliphoth)*. This is perhaps the most extensive interpretation of the qliphothic sigils. The qabalistic analysis does not follow the "standard" system.

Marcelo Ramos Motta (1979). *Liber CCXXXI—A Personal Research. Equinox V (2): 283-294.*

Ray Eales (1992). *Liber CCXXXI Visions by S. T. S. (Carcerorum Qliphoth) Equinox VII (1) 63-126.*

Robert Fitzgerald (2010) *A Gathering of Wings (Domus Mercurii)*. This is a more comparative study with visions explained and interpreted.

The Atus of Tahuti

O. The Fool, Atu 0. Aleph (א), △.

Other name: Le Mat

0. A, the heart of IAO, dwelleth in ecstasy in the secret place of the thunders.

O. The Fool is the first tarot Atu. In the Marseilles Deck, the Fool is unnumbered. The number Zero (0) in western mathematics comes before One (1). The Fool has been treated differently and is distinct from other trumps. The current numbering system for trump usually follows the Marseilles system.

The quotation describes the qabalistic and mystical characteristics of **Aleph (A, א)**. The Greeks and Romans personified this force as Hermes and Mercury respectively. Aleph is the transmuting energy between opposites. Here active Asar and receptive Asi, compare to God and the Universe, or God and Nature. The Fool is likened to an initiate on his course among the other atus.

IAO contains an active, a mediating and a receptive element. The three pillars of both Trees correlate to them as Mercy, Middle (or Equilibrium) and Severity. In the following sequences, the middle mediates the lateral ones: as progeny—Hadit, Ra-Hoor-Khuit, Nuit, or Father, Child, Mother; Active, Union and Passive; or numerical symbol (-, 0, +); or Stability, Balance, Change.

The **secret place of the thunders** is the abode of the Creator beyond comprehension, the formless void of Tohu and Bohu. Thunder is the Voice in the Silence, the revelation, the Word(s) of creation through Kether.

It is recorded in *Genesis* I: 2-5:

And the earth was without form [tohu, תהו], and void [bohu, ובהו], and darkness was upon the face of the deep. And the Spirit of God moved upon the waters.

Its *New Testament* parallel occurs in *John*: I: 1 as:

In the beginning was the Word, and the Word was with God, and the Word was God.

Sigils

The **Qliphothic Sigil** shows The Voice in the Silence. It is God in the beginning, expressing creation. The Word of Manifestation may be coded into the name of the Mercuric Sigil for Tau, Thath'th'thithεthuth-thiζ,

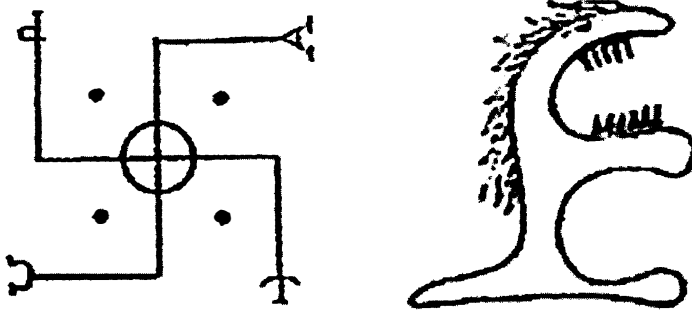

The **Mercuric Sigil** is a counterclockwise swastika with a circle at the intersection and dots between the arms. For over 3000 years, Hindus have it as a symbol for good. The swastika has arms ending with Greek letters. It ties the content of *Liber CCXXXI*, the Tarot to the Hebrew and Greek letters.

The swastika represents the Sphere of the *Primum Mobile*, the Beginning Whirlings, *Reshith ha Gilgalim*, ראשית הגלגלים, the universe in formation. It is Chaos in the process of organizing. The crossing represents the origin. The circle represents the organizing force. The dots represent essential energy. The letters TARO represent driving forces.

Comparison to Sigils of Tzaddi

The Qliphothic Sigil may connect to the upper portion of the sigil for Tzaddi. The oval has the semblance to the seed, the communication of light. It is the urge of Deity to create the universe.

The Mercuric sigils are more similar. The swastika is reversed in Tzaddi. The pattern is creation, initiation, with the four cherubs (K) in the corners, the lightning flash and the letters in combination indicate magickal formulas.

Genii

Aξu-iso-uξa [ξ = υ] Amprodias

The **Qliphothic Genius, Amprodias**, personifies the sigil as the Voice in the Silence.

Am	מא	Mother, origin
pro	פרפ	Progeny, fertile, productive, prefix meaning before, forward
dias	דאד	Hidden, secret, also division

An interpretation of its name is *The Hidden source of existence* or the *Genius before Duality*.

The **Mercuric Genius** is Aξu-iso-uξa [ξ = υ]. The middle letter (ξ) equals υ. A'in, the Path of the Devil. The analysis of this tripartite formula follows:

Aξu	Aou	This has the same connotation as the IAO formula. Osiris is a dark god comes to mind.
Iso	iso	Prefix for equal. Since the segments on either side of it are mirror images, their sum is Nothing (= ׀⌘).
uξa	uoa	The reverse of Aξu.

It is an analog to the IAO-OAI formula of *Liber LXVI vel Stellae Rubeae*. The name says *The Creator is the creation*, or *He is All is all*.

Rituals

Liber Viarum Viæ gives no ritual for this path. It says, "The transcending of all these; yea, the transcending of all these."

The mystery of Aleph is silence, pure being, Nothing, yet all encompassing. It is perfection, beyond intellect and intuition. It is the brilliance behind the Veil of Isis, the origin. The upper end of the path is at Kether, trigram ❖, 111, Purity.

Crowley finishes his appendix to *The Fool* with the following paragraph:

I praise the luxuriant Rapture of Innocence, the virile and pantomorphous Ecstasy of All-Fulfillment; I praise the Crowned and Conquering Child whose name is Force and Fire, whose subtlety and strength make sure serenity, whose energy and endurance accomplish the Attainment of the Virgin of the Absolute; who, being manifested is the Player upon the sevenfold pipe, the Great God Pan, and, being withdrawn into the Perfection that he willed, is Silence.

Liber 671 vel Troa, the Neophyte Ritual of the A.°. A.°, and subsequent *Pyramidos*, have a section where the candidate lies in the Hanged Man position. A series of strophes for each of the paths on the TL in order, alternates with the antistrophe, *He is under the shadow of the wings*. Though guilty under the *Declaration of Innocence* or *Negative Confession*, he is exonerated, and passes into Amennta.

For the path of *The Fool*, the statement in *Troa* is, “He is empty and a fool.” The parallel for *Pyramidos* describes the candidate by, “I am a fool and a flutterer.”

I. The Magus, Atu II. Beth (□), ♀.

Other names: The Mountebank, Le Bateleur, Trickster, The Juggler

1. The lightnings increased and the Lord Tahuti stood forth. The Voice came from the Silence. Then the One ran and returned.

The Magus, Atu I, in *The Book of Thoth* relates to Mercury, the messenger of the gods, carrying his caduceus. He is Prometheus who carried the fire from Heaven to the world. He represents Will. His symbol is the lingam, the means of creation, the word made flesh. Mercury is action, the law of reason, of duality, of chance. Wisdom and writing are also attributes of his Egyptian counterpart, Thoth or Tahuti.

The Magus was known historically as the Magician, the Trickster. With the Fool the combination becomes wisdom and folly, truth and uncertainty, and to the dynamics of Creation. As the Fool is Atu 0, and the Magus is Atu I, the 0 and the I are different aspects of an identity—message and messenger.

The letter Beth begins Creation. The Torah starts with it—בראשית. Berashith. It begins the word blessings, ברכות, Baruchoth. Berg (1988) points out this as the letter that opposes Chaos. Creation avoids the uncertainty of a random universe. Beth is the messenger energy-intelligence that expresses the unity of an all-embracing Force of the Lord. He continues, the intelligence of Beth is the interaction between his intelligence and higher cosmic intelligence. Beth is the metaphysical gateway between the two. Beth is the secret of Chokmah. It is the ultimate balance or blessing.

The lightnings, or the Lightning Flash is the message from the Ain Soph through Kether. It penetrates space created by the withdrawal of the First Emanation. After, the universe could share light through the sephiroth.

Lord Tahuti (\approx Thoth) symbolizes wisdom, knowledge, and communication—the Voice, the Word. He is the messenger, the scribe, the Egyptian god who invented writing. He is also Hermes or Mercury, a psychopomp to the Fool on his initiatory journey.

The Voice from the Silence is the source of the message in Aleph. Voice is communication. Silence is Nothingness. Ecstasy comes when the Voice and the Silence, subject and object, achieve union. This process is a two way street. To balance this relationship, and to make the man in the image of God (? or *vice versa*), the sephiroth had to be able to share. They had to both receive and reflect light. The Breaking of Vessels and formation of the Second Emanation produced the qabalistic light and vessels that define a sephira.

Then the One ran and returned. The lightning flash, the Voice from the Silence, goes from Kether to Malkuth. The vessel of Malkuth reflects the light back toward Kether. The Mercuric genius of Tau, Thath'th'thithꞥ thuth-thiꞤ, may bring the returning Word back to Chokmah.

Sigils

The **Qliphothic Sigil** shows a solar boat at night, with a crescent moon above. The curved swords are the pillars holding up the sky in the east and west. In the boat has the central Osiris with Tahuti standing at the prow and Ra-hoor abiding at the helm. Thelemites use this in the ritual in *Liber CC vel Helios (Resh)*, *Hail unto thee from the abodes of the night*. Superficially, the sigil may be interpreted as a face of the Magus or Psychopomp.

In showing the solar boat at night, the sigil is tied to the daily course of the sun. So it demonstrates the evening of the first day, the dark and the

light, contrast and division. Compare $0 = 1$. The sigil is parallel In *Genesis I: 2, 5* where it says:

And God said, Let there be light: and there was light. And God saw the light and it was good; and God divided the light from the darkness. And God called the light Day, the darkness he called night. And the evening, and the morning were the first day.

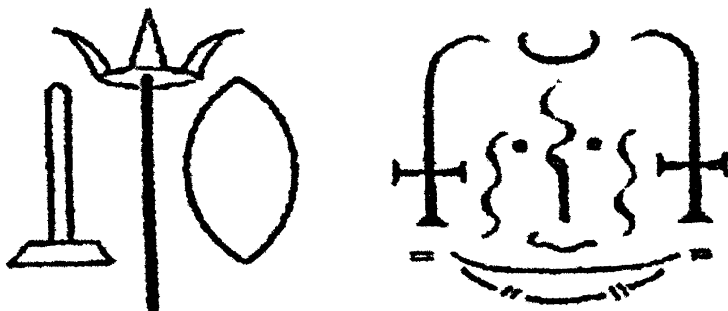

The **Mercuric Sigil** shows a vesica at the right, a crowned staff in the middle, and an inverted T at the left. It represents the Thelemic triform understanding of the Universe. The central unit corresponds with the Central Axis of the QT with Kether as the crown. It symbolizes IAO. The lateral units represent opposites—active and passive. Collectively the sigil is an expression of dichotomy—God and Nature, male and female, lingam and yoni. It represents the basic $0 = 1 = 2$ formula of the Universe.

Comparison to Sigils of Gimel

The qliphothic sigils for Beth and Gimel look like faces with bilateral symmetry. Instead of the face of night of Beth, Gimel represents the face of day, or division of the firmament from the waters.

The Mercuric sigils together show the sexual aspect of Nature, division for love's sake, for the chance of union.

Genii

Beξθaoooabitom Baratchial

The **Qliphothic Genius** is **Beξθaoooabitom**.

Be	Beth	The letter Beth itself, meaning house
a	a	The letter for Tarot Atu 0, The Fool
ooo	ooo	Trigram ⚊, the Nothing in its three forms, from <i>Trigrammaton</i>
bitom	bitom	The Enochian Fire of Creation

The name of the genius means, *The house of the Magus, the carrier of the word*. He brings fire and the word of the Æon, from Heaven.

The **Mercuric Genius** is **Baratchial**.

Ba	בא	That which is manifested; progression, locomotion; he who comes
ra	רא	Visibility, geometric radius from point, to see
tch	תח	United to one another, central point, direction
ial	אל	Suffix indicating an Angel

The name suggests a *Genius who leads from a Source, i.e., an Angel* between the Deity and the universe. It describes the role of the Magus.

Rituals

Liber Viarum Viae attributes *Liber B vel Magi, Liber I* to this path. This supports the position of the Magus as Atu I.

The content of *Liber I* describes opposites or polarities in nature. The four weapons represent the Tarot suites: Wand = Creation, Cups = Preservation, Swords = Destruction, and Coins = Redemption. Among them is also the TARO, TROA (the gate) and ROTA (the wheel). However, all is illusion. Reality is unity or truth. It is synonymous with Nothing, the Ain.

In *Troa*, "He is a liar and a thief." In *Pyramidos*. The initiate admits, "I am a liar and a sorcerer."

II. The High Priestess, Atu III. Gimel (♁), ♃).

Other names: The Popess, La Papessa

2. Now hath Nuit veiled herself, that she may open the gate of her sister.

Atu II, The High Priestess on the Marseilles Tarot deck wears a triple tiara. She is the female counterpart of Atu V The Pope. The tiara reflects back to the historic name, The Popess. The Crowley Thoth Deck shows her as II The Priestess, as Isis has the Bow of Artemis on her lap. At the bottom is a camel and other signs of nascent activity. Crowley (1944) attributes the path to the highest spiritual feminine, above the Abyss.

The **Veil of Isis** (= Nuit) separates the brilliance of Kether, the World of Atziluth, from Briah. The Veil masks the Kether end of the paths of Aleph, Beth and Gimel.

The **gate of her sister** is Daleth, the first path entirely within Briah, below the Veil. It anchors the Upper Triad. In opening it, the High Priestess reveals the light of Kether.

Sigils

In cosmic terms, the **Qliphothic Sigil** parallels the account of the Second Day of Creation in *Genesis* I: 6 – 8:

6. And God said, Let there be a firmament in the midst of the waters, and let it divide the waters from the waters.
7. And God made the firmament, and divided the waters, which were under the firmament from the waters which were above the firmament: and it was so.
8. And God called the firmament Heaven. And the evening and the morning were the second day.

This Thoth Card is a depiction from the 19th Æthyr of *The Vision and the Voice*.

I am the Angel of the moon. I am the veiled one that sitteth between the pillars veiled with a shining veil, and on my lap is the Open Book of the mysteries of the ineffable light. I am the aspiration unto the higher;

I am the love of the unknown. I am the blind ache within the heart of man. I am the minister of the sacrament of pain. I swing the censer of worship, and I sprinkle the waters of purification. I am the daughter of the house of the invisible. I am the Priestess of the Silver Star.

The pillars on the sides may represent the Double Wands of Power. The Open Book of the mysteries of the ineffable light is at the bottom. The sword represents balance in nature. The median oval is the secret word, the fire. God speaks it. The out-curving wands are the opening gate. The sigil is a symbol of the elements.

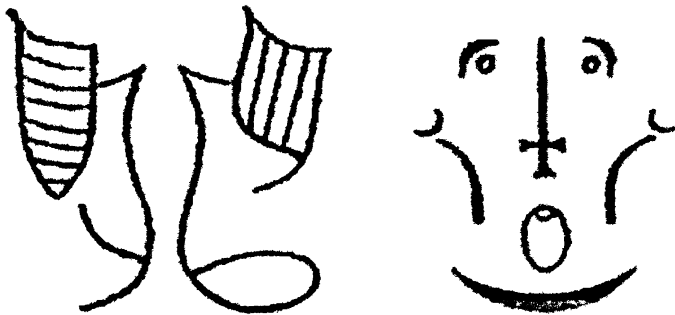

The **Mercuric Sigil** has two parts. It represents Mother Nature, or Nuit and her sister together as Isis and Nephthys. The sigil looks like a gate. The halves suggest a shape for Nuit. The door on the right has vertical lines with the one on the left, horizontal ones, suggesting contrast with each other.

The bottom of the right hand jamb is a closed oval. It suggests the receptive symbol, O. The bottom of the left hand jamb has an open funnel, an active aspect, the I. They represent contrast in Nature. The space between suggests form seems to arise from Nothing.

Comparison to Sigils of Beth

As mentioned under Beth, the qliphothic sigils look like faces. This sigil is an extension of the concept of separation — air, water and earth, the revealing of Nature. The sequence follows the Biblical account in general terms.

Genii

Gitōnosapōλλois Gargophias

The **Qliphothic Genius** for Gimel is called **Gargophias**. It is a feminine force whose name contains two elements:

- Gar** גַּר Movement, united to the root of organic extension, encroaching; where one meets in the course of a journey.
- gf** גִּפ Conservation, a body, dryness, enclosing, incorporating, for defense
- ias** יָאֵס Determinative suffix for a genius.

Here is the *Creation of Nature* as man begins to experience it.

The **Mercuric Genius** of Gimel is **Gitōnosapōλλois**.

- Gitōn** Giton Suggests Giants, Titans or Nephalim of *Genesis* 6: 4.
- os** os Relative or demonstrative pronoun (who or which).
- ap** ap Enclitic **ar** or **ara** that gives a further emphasis to the previous material or word.
- φollois** phallois May be a play on words between the ideas of *φалλος*, phallus, and *φωλεος*, pholeos, meaning den. The corresponding verb *φωλεω*, means to lurk in a hold, or lie torpid in a den (as for a bear).

The name of the Genius suggests *Great force*, as an archetypal Giant lying in a potential state for later manifestation.

Rituals

Liber Viarum Viæ correlates Gimel to Supreme Ecstasy of Purity. *Liber LXXIII*. This is an unpublished liber called *The Urn*. One can see the relationship of *urn* to Nature, and even to the shape in the Mercuric Sigil. However, no understanding is possible without its text.

In *Troa*, the candidate is described by, “He is fickle and untrusty.” This is reiterated in *Pyramidos*. There, the initiate admits, “I am so fickle that I scorn the bridle.”

IV. The Empress, Atu III. Daleth (ד), ♀.

Other name: L’Imperatrice

**3. The Virgin of God is enthroned upon an oyster-shell;
she is like a pearl, and seeketh Seventy to her Four.
In her heart is Hadit the invisible glory.**

The path of Daleth correlates to the Empress, the planet Venus, and alchemical salt. Salt symbolizes the passive, receptive principle of nature. On the Thoth card, her right hand she holds a lotus, a symbol of the Holy Grail. The card depicts a high level glyph of the feminine.

Berg (1990) adds that Gimel and Daleth are intrinsic opposites. They relate to one another as symbols for the two sides of the Veil of Isis. He further says that the internal cosmic energy of Daleth is impoverishment. However, it is an energy-intelligence of great power when combined with Gimel. The two letters parallel the Yang and Yin, the giving and receiving powers of the universe. There can be no giving without receiving, hence the paired nature of these two letter energies. Gimel and Daleth provide the metaphysical space by which humanity maintains the *As above, so below* principle. This produces the balance and harmony.

The path relates to the **Virgin of God**, Venus. Botticelli painted *The Birth of Venus* standing on a shell. It now hangs in the Uffizi Gallery in Florence. The **pearl** symbolizes innocence and purity. It also signifies genius in obscurity. Cirlot (1971) says that the chosen hides a precious stone at her breast. It alludes to a mystic center, a pearl, hidden in the **oyster**. The pearl represents the union of fire (I) and water (O) in the human soul. **Seventy** is the number of Sud, סוד, the secret Word.

Four by gematria is אבא, father. This is the counterpart to Venus. Daleth is the gate, the opening of the Veil of Isis. Here is the high-level mystical marriage between Empress and Emperor. Three plus four equals seven, the path of Za’in.

In her heart, Daleth holds the secret of Hadit, both metaphysically and esoterically, Hadit is the Goat, Set, an icon of The Devil. Daleth is Venus in Briah, the Formative Mother. The Empress is to the Emperor as Nuit (Isis) is to Hadit.

In her heart is Hadit the invisible glory is a paraphrase of *Liber XXXI, Chapter II, verses 3 and 4*,

In the sphere I am everywhere, the centre, as
She, the circumference, is nowhere found.
Yet she shall be known + I never.

Sigils

The outline of the **Qliphothic Sigil** forms a gate, תרעא, *Troa*, Daleth. This also represents the womb, house of gestation. The downward pointing triangle, the symbol of Thelema, is The Fool, the candidate. The candidate is supported within the womb. The AVD is the secret energy, nurturing him. It is also the word for magic power. The base suggests an oyster shell.

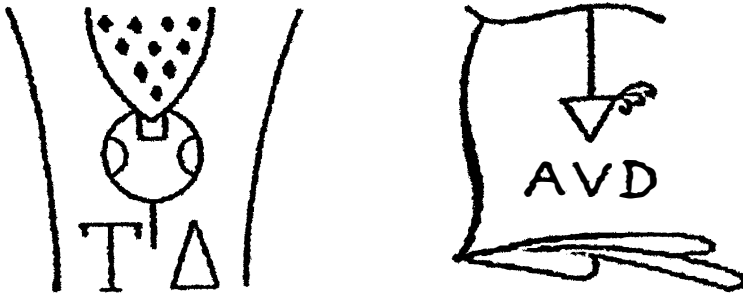

The **Mercuric Sigil** for the path of Daleth has two ascending outward curves on the sides, a gate. It frames the other elements. T and Δ at the bottom symbolize phallus and vulva, male and female.

The middle of the sigil has a circle with a line below. This is the Greek letter Koppa, used only as the number 90, the number of initiation. The circle and the line are also the O and I. It symbolizes the secret seed. The center takes the form of a thistle.

The ten drops in the cup (vulva) are arranged in an inverted equilateral triangle. They are awaiting fertilization. This is the arrangement for the permutations of Tetragrammaton, יהוה, the tetractys.

The whole sigil suggests a passage, opening upward to a higher level of initiation. Downward, it marks the descent toward manifestation.

In Chapter 42 of *The Book of Lies* it says, in part. It was also referred to for the path of Gimel.

This desert is the Abyss wherein is the Universe.

The Stars are but thistles in that waste.

Yet this desert is but one spot accursed in a world of bliss.

Now and again Travellers cross the desert;

they come from the Great Sea, and to the Great Sea they go.

As they go they spill water; one day they will irrigate the desert,
till it flower.

Comparison to Sigils of A'in

The Qliphothic sigil shows an initiate who has poured his blood into the cup of Babalon. The sigil for A'in shows Horus/Set, and indicating the spilling of seed.

The Mercuric Sigil for Daleth shows a gate and an initiatory path. It describes nature, and the effects of fertilization. The sigil for A'in (and its Tarot Atu XV Devil) shows the transmission of that seed.

Berg (1988) treated Gimel and Daleth together, since they approached the Lord together during the creative process. Gimel symbolizes the positive, giving aspect. Daleth symbolizes the negative, receiving one. Together they are the energy-intelligences of the all-embracing unified whole.

Genii

Ḍḥnaḏartarωθ [ḏ = st] Dagdagiel

The **Mercuric Genius** for Daleth is **Ḍḥnaḏartarωθ [ḏ=st]**. The name can be interpreted directly.

Dηn	Den	For a long while, long ago; or Dyn meaning force, motion.
azart	astart	Similar to Astarte, the Babylonian Goddess equivalent to Venus.
tarωθ	tarot	Another form of ταρω, the four-letter form of Tarot found in the sigil for Aleph in the Houses of Mercury.
iz	ist	Suffix indicating a Genius.

The name of this Genius encodes an archetypal relationship of the path to views of Venus and the cycle of the court cards. It also points to the union of the I and the O, and sexual congress. *The Virgin of God is the gate.*

The **Qliphothic Genius** for Daleth is **Dagdagiël**.

Dag	דג	Solicitude or anxiety, worry, energy; doubled for emphasis.
Iël	ל	Suffix indicating an Angel.

Rituals

In *Viarum Viae*, the path of Daleth refers to *The Incarnation of the Inmost Light and Liber DLV Had* and *Liber AL* Chapter II. The ritual of *Liber Had* invokes a Thelemic life style.

In *Troa*, “He is unchaste and idle.” In *Pyramidos*, the initiate admits, “I am unchaste, voluptuous and idle.”

V. The Emperor, Atu IV. Heh (⌈), 𐌆.

Other name: L’Empereur

4. Now riseth Ra-Hoor-Khuit, and dominion is established in the Star of the Flame.

The text suggests an interpretation different from the traditional view. The verse says that **Ra-Hoor-Khuit** takes **dominion** over the **Star of the Flame**. Ra-Hoor-Khuit is Horus, ruler, as initiator, of the current æon, the

Crowned and Conquering Child, In a commentary on the nature of them in *The Vision and the Voice*, for the 1st Æthyr it says:

The final manifestation. All leads up to the Crowned Child, Horus, the Lord of the New Aeon.

The **Star of the Flame** refers to the New Æon of the Child, his conquered domain. It also is the Microcosm of the Emperor, indicated by the five alchemical elements in the Mercuric sigil. Ra-Hoor-Khuit is equated with the Emperor.

The letter Heh is assigned to Aries (♈) as far back as the *Sepher Yetzirah*. It marks the beginning of the zodiacal year. Throughout Tarot history, The Emperor is consistently Atu IV. It occurs between the Empress and the Pope. The attributions are based on tradition from the *Sepher Yetzirah* (its zodiacal correlates) and the sequence of the signs in the zodiac. Supporting data include the following Class A material: *Liber XXXI*, *Liber CCXXXI*, and the 6th and 1st Æthyrs in *Liber CDXVIII*, *The Vision and the Voice*,

The Emperor on the Tarot card represents the alchemical, male, fiery element sulphur (♁). In the Thoth Tarot deck he sits in the form of the symbol for sulphur. He rules over paternal and secular power. The scepter and orb in his hands symbolize **dominion**, establishment and government. The shield in the lower left represents the alchemical Red Tincture, the complement of the White Tincture in The Empress. The Emperor's authority devolves from Chokmah, with Wisdom indicated by the light coming from over his left shoulder.

The note relating to Sulphur, the Pentagram and the Star in the 6th Æthyr of *The Vision and the Voice* (Crowley, 1972) says:

Sulphur (♁) is the Active Fiery Nature, and the Pentagram [★] the Microcosm of the Elements. But Atu IV, "The Emperor" refers to Heh = 5, for the Pentagram, [★] and he forms sulphur [♁] by the position of his arms and legs.

As an aside, Aiwass spoke from over Crowley's left shoulder during the dictation of *Liber L*. The authority comes from Chokmah, the attribution of Hoor-Paar-Kraat.

The message of the path is dominion, rule, authority, organization, and natural law. Aries, the first sign in the zodiacal year adds correlates to leadership of The Emperor or Ra-Hoor-Khuit.

Sigils

The **Qliphothic Sigil** shows the face of a man with a chain of office, *i.e.*, an official. The raised dark brows show awareness. The double dots of the eyes add awareness of duality, understanding and wisdom needed for good rule. The nose, in the shape of the moon, suggests the foundation of judgment. The chain of office hangs around his neck.

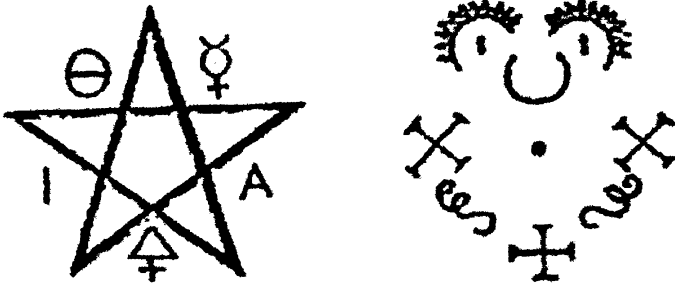

The **Mercuric Sigil** for Heh is an upright pentagram, a star (★). The *Star of the Flame* is the Microcosm. It is described in the Class A text, *The Vision and the Voice*. Between the points of the pentagram are the symbols for the three alchemical elements, salt and mercury, with sulphur at the bottom. The additional elements are represented by I and A. It represents the realm of The Emperor, or that of Ra-Hoor-Khuit.

⊖ = Salt = Earth

♁ = Mercury = Air

I = I(gnis) = Fire

A = A(qua) = Water

♁ = Sulfur = Spirit

The star is a pentagram. The five alchemical elements are arranged in an inverted pentagram, a second star, as in the sigil for Cheth.

The position of the Mercuric Sigil for Heh is switched reciprocally with that for Vau in the table of sigils. On Crowley's original drawing, sent to Fuller, the Hebrew letters are in pencil. The letter Vau has an underlying light Heh in pencil. Crowley originally may have drawn the two sigils out of

order, recognized the problem, and pointed out a correction to Fuller. Fuller, however, drafted the published version in the arrangement based on Crowley's original. The sigil and the Star of the Microcosm relate to Heh, as indicated in the published version.

Comparisons to Sigils of Cheth

The Hebrew letters Heh (ה) and Cheth (ח) are very similar, easily confused, and are sometimes substituted for one another. Note the similarity between Abrahadabra and Abracadabra.

The table of Hebrew letters directs a comparison between Heh and Cheth. Both have stars. The former is the Star of the Flame. The latter is a ten-rayed dark sun made of two pentagrams, possibly the Sun behind the son, or Hoor-Paar-Kraat. The discussion of the path of Cheth, below, includes the comparison.

Genii

Hoo-oorw-iz Hemetherith

The Qliphothic Genius is Hemethterith.

emeth	Hemath	The color red of iron or blood ($\alpha\mu\alpha$). Red is associated Mars, the ruler of Aries, and the Thoth Emperor card.
erith	terith	A modified spelling of Therion ($\theta\epsilon\rho\iota\omicron\nu$), meaning Beast or mammal.

The name reinforces The Emperor as the *Red Ruler*, or Warrior.

Liber XXXI III: 2-3 expresses the war-like nature of The Emperor in terms that apply to Ra-Hoor-Khuit, *viz*:

Hold! Raise the spell of
Ra-Hoor-Khuit.
Now let it be first understood that I am
a god of War and of Vengeance. I shall
deal hardly with them.

The **Mercuric Genius** for Heh is **Hoo-oorω-iꝛ**. The tripartite nature of the name is important, and occurs in the names of many of the genii. The nature of the universe in *Liber CCXXXI* clearly relates tri-radiate symmetry. The analysis of the name of this genius is:

Hoo	Hoo	Hoor-paar-Kraat, an aspect of Horus
oorω	ooro	Another indication of Horus
iꝛ	its	Suffix implying Genius

The name of the Genius indicates *Horus as Ruler*.

In Regardie (1984), the Threefold Name of the Goddess, **ΘΜΔΗ** occurs as **ΘΜΔΗΥ**, **ΘΜΔΗ†** and **ΘΜΔΗꝛ**. What is the significance to the different ending in each?

Ritual

Liber Viarum Viae calls the path of Heh “The formulation of the Flaming Star,” and refers to *Liber V vel Reguli*. The Flaming Star relates to Briah or the Æon. See the Class A *Liber 813 vel Ararita*, Chapter 1.

The ritual *Liber V vel Reguli* uses averse pentagrams. These can relate to the star in Heh and double black star in the Mercuric sigil for Cheth Crowley devotes much space to discussing its formulas, their meaning, and the nature of the ritual, in *Magic in Theory and Practice*.

In the ritual *Troa* it says: “He is quarrelsome and domineering” The corresponding sentence in *Pyramidos* is, “I am a bully and a tyrant crass.”

VI. The Hierophant, Atu V. Vau (Ⓛ), Ⓞ.

Other name: The Pope

5. Also is the Star of the Flame exalted, bringing benediction to the universe.

According to Berg (1990), Vau has the powers of prophecy. She functions to prevent the destruction of the universe by violence. Simultaneously, it permits access to the infinite force of the Lord. He continues later that Vau

harbored a vision of a future world, unified by her energy-intelligence. She was eager to unleash the energy of the central column. Cosmic Vau has the feasibility of maintaining universal stability and Tetragrammaton.

The Star of the Flame continues from the previous path description. Here, Microcosm and temporal rule are elevated to a spiritual level. This is part of the initiatory process. Horus is the Lord Initiating.

Bringing benediction to the universe is the function of the Hierophant. He symbolizes spiritual rule. He is the priest or prophet, the Initiator. He brings the message from the realms of the Gods, the Macrocosm, to the realm of man, the Microcosm.

Sigils

The **Qliphothic Sigil** shows Yods emphasized on a diagram of the TL below Kether. The path of Vau would connect the two Yods at the right. This is a more abstract interpretation of the Hierophant as a religious leader. It emphasizes the light from above. Another interpretation suggests the Holy Guardian Angel.

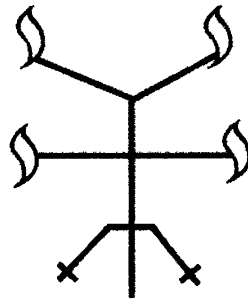
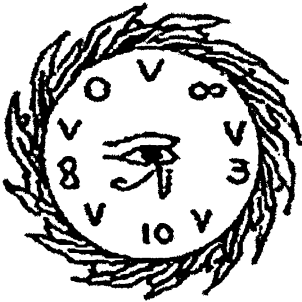

The **Mercuric Sigil** identifies the Prophet of the Æon.

The eye of Horus (Heru-Ra-Ha as HPK and RHK) at the center is the focus around which the world revolves in this Æon. It also connects Horus to Crowley.

This sigil correlates to *Liber X vel Porta Lucis*, another Class A liber. The liber refers to a small dark orb, wheeling in an ABYSS of infinite space. In *Liber X*, V.V.V.V.V. (Crowley as an 8° = 3°, Master of the Temple) is a ray of that light (the Light of Wisdom). He is a messenger (The Hierophant) to the small dark orb, earth in Malkuth in Assiah. This explains the VVVVV in the disk.

Liber X vel Porta Lucis explains the numbers between the Vs as follows:

0	I come from the Ages beyond the Ages	— HPK
∞	from the Space beyond your vision	— Aiwass
8 and 3	as Master of the Temple	— VVVVV
10	to Malkuth in Assiah, Earth	— HGA to Man

Comparison to Path of Kaph

The table of Hebrew letters directs comparison between the sigils for Vau and Kaph. The whirling sun moves as the Wheel does in the sigil for Kaph. The noticeable difference is that the former whirling sun is pentameric, the latter hexameric.

Genii

Vuaretza – [a secret name follows] Uriens

The name for the **Qliphothic Genius** is a variation on Uranus, the God of the Heavens.

The name for the **Mercuric Genius** includes both a mechanism and a method to bring about manifestation.

Vu	ו	The letter Vau, the rod or nail, the rod of Prometheus, the phallus.
aretz	ארץ	Earth. The path of Vau functions as an intermediate between the gods and the earth (man).

[a secret name follows] It is just that. Such a name empowers the path through the discharge of the energy with the transmission of the word. The secret name could be the name of a personal HGA, since it acts as a Hierophant for the individual.

The name indicates the *Genius who connects heaven and earth*.

Rituals

Liber Viarum Viæ assigns *The Forthcoming of the Hierophant* and *Liber VIII.* (8th Æthyr in Liber 418) to Vau. This is a ritual for attaining Knowledge and Conversation with a Holy Guardian Angel.

Liber 671 vel Troa describes the candidate by “*He is cruel and untrusty.*” In *Pyramidos* the candidate says, “*I am untrusty, cruel and insane.*”

VII. The Lovers, Atu VI. Za’in (†), II.

Other name: The Brothers

**6. Here then beneath the winged Eros is youth,
delighting in the one and the other.
He is Asar between Asi and Nepthi;
he cometh forth from the veil.**

The text relates to the Thoth Tarot deck and to the Mercuric Sigil. In both, the upper center has a winged Cupid or **Eros**, god of Love, with his bow and arrow. **Youth** represents the New Æon.

Asar is Osiris, God of the Underworld or Darkness. He emerges into the World, Nature, which is depicted in the Mercuric Sigil for Gimel as **Asi** and **Nepthi**. The analog is Hoor-Paar-Kraat, at midnight, emerging from behind the Veil of Silence, at Dawn, as Ra-Hoor-Khuit.

Sigils

The **Qliphothic Sigil** shows an arrow aiming upward and piercing Eros (as a scimitar). The two Crowley Gs are alike, rather than opposite as in the Mercuric Sigil. This sigil may apply more to the Brothers. There is division implied by the scimitar. The motion of the sigil is upward, piercing of the veil. If downward, it expresses disunion.

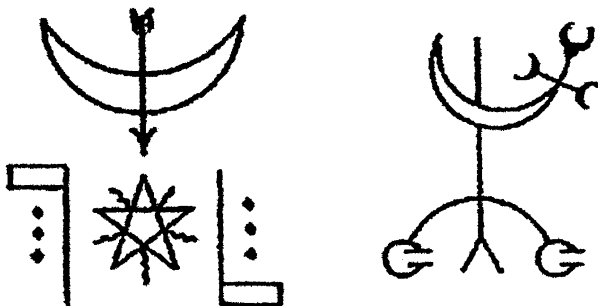

The **Mercuric Sigil** for Za'in has a bow as a crescent with a downward pointing arrow. The median arrow suggests more balance, as it does on the Tarot card. It represents **Eros** or Cupid, as in the Thoth Tarot deck. The lower half depicts Gemini, the complementary Twins. The arrow represents Will.

Below is a pair of young figures. They symbolize libido and the aspiration for union.

The two flag-like neters have god-like connotations. They are opposite, as lovers. The three dots on each side represent levels at which the mysteries of the card may apply.

The text names the neters Asi (= Isis) and Nepthi, with Asar. The two are also located at the top of the Thoth card, and compare directly to Eve and Lilith. The central double pentagram is the Sun behind the son, Heru-Ra-Ha.

Comparison to Path of Daleth

The candidate for initiation is in Daleth. Love (union) is the gate to initiation.

Genii

Zooasar Zamradiel

The **Qliphothic Genius** is Zamradiel. His name is analyzed as follows:

Zam	𐤆	System or scheme, an operation, plotting
rad	𐤓	Moving with firmness; a wheel, a sphere, a veil.
iel	𐤍	The suffix indicating an Angel

The name indicates *An Angel of action*.

The **Mercuric Genius** for Za'in is **Zooωasar**.

Zoon ζοον Greek for a living being or animal, or a figure or image
ω ο Horus (since it is followed by Asar, Osiris).
asar ασαρ Osiris.

The name of the genius expresses the image of duality, as in Horus/Set or Hoor-Paar-Kraat/Ra-Hoor-Khuit. It expresses *Action by Horus*.

Ritual

Liber Viarum Viae lists the appropriate ritual as “The Utterance of the Pythoness, Liber MCXXXIX.” The title suggests a relationship to the Delphic oracle and its role in mythology or religion. The book is unpublished, or unknown. *Liber MCXXXIX* has no title in the list of libers in *Equinox III* (9).

In *Troa*, the candidate is described as, “He is stubborn and stupid” In *Pyramidos*, the initiate admits, “I am trusty, cruel and insane.”

VIII. The Chariot, Atu VII. Cheth (Π), ☿.

**7. He rideth upon the chariot of eternity;
 the white and the black are harnessed to his car.
 Therefore he reflecteth the Fool,
 and the sevenfold veil is revealed.**

He symbolizes **The Fool**. The perfect balance of the **chariot of eternity**, life, does not require a driver. The innocence of the driver allows the chariot free rein (pardon the pun). His innocence is an important part of his role as the seeker or carrier of the Grail.* The kerubs represent fixed signs in the zodiac. The kerubs are composite. Their body parts and heads interchanged.

* Mandelbaum (1993): The innocence of Phaeton is thinking he could successfully ride the chariot in its daily course of the sun.

The course of life is a mixture of **white** and **black**, good and evil, conscious and subconscious.

The Fool seeks the Holy Grail. The gematric value of Cheth, חית is 418, the number of the formula Abrahadabra, אַבְרָהָאֲדָבְרָא. By this formula the Initiate (Microcosm) unites with his Universe (Macrocosm)—4 (**Earth**) + 3 (**Heaven**) = 7 (**Union**).

The Thoth deck card shows an armored rider in a chariot. Four counter-colored kerubs pull the chariot. On the top of his helmet is the crab, symbolizing Cancer. The charioteer holds the Holy Grail, the most significant symbol on the card. In the center of the Grail is blood, the spirit surrendered to the last drop by the initiate in attaining the Great Work.

Sigils

The **Qliphothic Sigil** is a prone initiate with a connection to the lion-serpent over him. It has the head of a mammal and the scales and tail of a serpent. The upper figure symbolizes the Holy Guardian Angel, whose Knowledge and Conversation is a major step on the path of initiation. The sigil shows an Astral connection.



The **Mercuric Sigil** for Cheth is a dark 10-rayed star, or superimposed upright and inverted pentagrams. The points of the upright pentagram are straight. Those of the inverted one are wavy. The 10-pointed star symbolizes Heru-Ra-Ha, the combination of two pentagrams, Hoor-Paar-Kraat and Ra-Hoor-Khuit. Here is the dark origin of the message, and the messenger. It indicates a more spiritual level of awareness.

Comparison to Path of Heh

The two Mercuric sigils are double pentagrams. As a dark sigil, it emphasizes the origin, the brilliance at midnight, HPK. As a light sigil, it emphasizes the bright light of dawn, the initiator, RHK. They may be analogous to Macrocosm and Microcosm respectively.

Genii

Chiva-abrahamadabra-cadaxviii Characith

The name of the **Qliphothic Genius** is Characith:

Char חר Elementary existence, the straight line, consuming ardour

chith חת Retrenchment, scission, suspension, cut

or

cith סת Every kind of veil, of darkness. Cf. Seth

The name indicates the Genius of *the Dark or Hidden Side* (? Hoor-Paar-Kraat).

The **Mercuric Genius** is **Chiva-abrahamadabra-cadaxviii**. This is a tripartite name as 1) Beast, 2) Abrahamadabra; 3) 418 and AA mixed. In *Liber 777* Crowley gives several words for line 19 that bear on this sigil and name:

Chiva	Chiva	Transliteration of a Hebrew for Beast, חוה, Chiva, as 841, is a hidden arrangement of 418. The square root of 418 is 29, a prime number that Crowley attributes to the magick force itself.
Abrahamadabra	אַבְרָהָאֲדַאֲבְרָא	A major formula in the Æon of Horus. 418. Crowley elaborates on the mysteries of this word in <i>Liber 777</i> . It is the formula of the Great Work.
Cadaxviii		An interpolation of CDXVIII, 418, and AA. CDXVIII symbolizes Abrahamadabra. <i>Liber 418, The Vision and the Voice</i> , describes the evolution of the Æon. The AA is A.'. A.'., the Silver Star, the Star of Unconquered Will, and Crowley's mystical order.

The name of the genius becomes: The Beast—Abrahamadabra—418 A.'. A.'. The name explains *the magic force in the Æon of Horus* and the role of The Beast.

Rituals

Liber Viarum Viae calls this path “The Ritual of the Holy Grail. *Liber CLVI vel Cheth vel Vallum Abiegni*.” It is the Class A liber that gives an account of the task of the Exempt Adept. It uses the symbols of a particular plane, not intellectual. Regardie (1974) puts *Liber Cheth* in his section on sex magic. The number 156 is the number of Babalon. Here it refers to the ritual of the Holy Grail.

In *Troa*, the candidate is described as, “He is cruel and untrusty.” In *Pyramidos*, the initiate says, “I am a fool and frivolous and vain.” Note the connection to The Fool, Atu 0.

IX. Lust, Atu VIII. Teth (♃), ♂.

Other names: Strength, Fortitude

8. Also came forth mother Earth with her lion, even Sekhet, the lady of Asi.

In the *Zohar*, Teth proposes that creation of the world through her would be good (טוב, Tov). The intelligent-energy of good expresses itself physically when man acts in a sharing way. Since everything done on earth by man reflects in the cosmos (= *As above, so below*), good impulses from Teth infuse the cosmos with blessing.

The text in *Liber CCXXXI* connects Teth to the Tarot Atu Lust. Here is **mother Earth**, Babalon with **her Lion**, The Beast. There has been no question about the nature of the path, just its position in the Tarot sequence.

The association between Teth and Leo is historic. The text of *Liber CCXXXI* relates line 8, Atu VIII, to the lion. In *Liber 777*, column XIV, line 19. It is Strength in the position of Atu VIII. Since the Roman numeral indicates the Marseilles deck position of the trump cards, using VIII seems more appropriate.

By interchanging Lust as Atu VIII with Adjustment (VIII in the Thoth deck) the natural sequence of the constellations agrees with the character of the zodiac sign. Waite (1910) made the switch from this historic sequence

where it was XI. Crowley followed the Golden Dawn in *Liber 777*, but reverted to the Marseilles sequence later.

The Egyptian goddess Sekhet, or Sekhmet is the wife of Ptah (Lurker, 1974). She was the mighty goddess of war. She spread terror. The henchmen of Set and even the serpent Apophis succumbed to her. She was seen as a lioness or as a woman with the head of a lion. She represents strength and control.

Sekhet (with her lion), the lady of Asi correlates Sekhet to the earthly counterpart of Isis/Nuit. On this path she is also the Scarlet Woman, who has all power. The **lion** is The Beast, pictured on the Tarot card where Babalon is astride the many-headed Lion. She holds aloft the Holy Grail. It is cognate with the Mercuric Sigil. In *Liber XXXI I*: page 2-3 (15-16) it says:

Now ye shall know that the chosen
priest + apostle of infinite space is
the prince-priest the Beast; and in
his woman called the Scarlet Woman is
all power given. ...

For he is ever a sun, and she a moon. But
to him is the winged secret flame, and to
her the stooping starlight.

Sigils

The **Qliphothic Sigil** shows the lion-serpent, Baphomet, with the head and torso of a lion and the long tail of the snake. The four vesicas suggest his grounded physical nature.

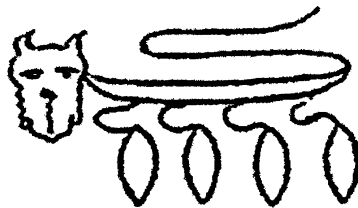
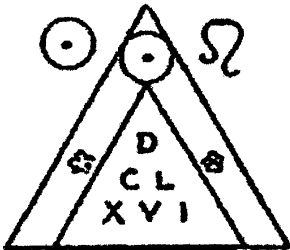

The **Mercuric Sigil** for Teth is more abstract in showing Babalon and The Beast. It has the symbol for the sun and the zodiacal sign for Leo. Leo is ruled by the Sun. Below them is an equilateral triangle. This represents the wings of Nuit. Hadit, the Sun, traveling in its course, is here at the top, at Noon (as on the Stele of Revealing). The Beast, CCLXVI is *under the shadow of the wings*. The symbols at the middle of each wing are roses. The right rose is dark; the left one is light. The dark rose derives its color from the blood of Adonis, or Venus, or Cupid. It suggests that the dark rose in the sigil should be red. This reinforces the sexual symbolism, or the union of the alchemical red and white tinctures.

The sigil summarizes the Great Work. It interprets the Stele of Revealing in *Liber CCXX I*: 14, but at a less esoteric level.

Above, the gemméd azure is
The naked splendour of Nuit;
She bends in ecstasy to kiss
The secret ardours of Hadit.

A related quote from *Liber 418, The Vision and the Voice*, emphasizes the earthly aspect more overtly.

O Babylon, Babylon (sic), thou mighty Mother, that ridest upon the crownéd beast, let me be drunken upon the wine of thy fornications; let thy kisses wanton me unto death, that even I, thy cup-bearer, may understand.

Comparison to Path of Shin

The Mercuric Sigil for Teth shows a two-dimensional, the latter a three-dimensional, figure for Shin. They both symbolize Babalon over The Beast, or Nuit over Hadit. They are *under the shadow of the wings*. This is repeated in the strophes and antistrophes in the rituals *Troa* and *Pyramidos*.

Together Shin and Teth become the transform element of the LASH TAL formula. He discussed it extensively in Appendix VI to *Magic in Theory and Practice*. An alternative interpretation, using Greek kabalalah, can be seen in Appendix III of the present study.

Genii

ΘαξΖer-a-dekerval Temphioth

The **Qliphothic Genius** is **Temphioth**.

Tem תמ Perfection, integrity, either physically or morally: truth, justice, sanctity, all the virtues

or

Tem תמ An opening, a pit, a dilation

phot פות Every idea of dilation, easily opened, space, impassive; act of persuading, deceiving.

This name expresses *The perfection of Babalon as the Scarlet Woman*.

The **Mercuric Genius** is **ΘαξΖer-a-dekerval**.

ΘαξΖer Θαλος A young shoot or branch. Metaphorically it is a scion or child. The αξΖer could also be the Greek Αστηρ (= Star)

or

ΘαξΖer Alosther A probable reference to Crowley's assumed first name.

a a The transform element, as in IAO. It may represent The Fool. It implies *from* or *of the line of*.

dekerval Matches a quotation in the *Equinox of the Gods* where Crowley, describing his boyhood writes:

Edward Crowley was an Exclusive Plymouth Brother, the most considered leader in that sect. This branch of the family of Crowley has been settled in England since Tudor times, but is Celtic in origin, Crowley being a clan in Kerry and other counties in the South-West of Ireland, of the same stock as the Breton '*de Querouaille*' or "*de*

Kerval” which gave a Duchess of Portsmouth to England. It is supposed that the English branch—the direct ancestry of Edward Alexander Crowley—came to England with the Duke of Richmond, and took root at Bosworth.

The genius has a blind name for *Aleister Crowley as an initiate*. The sigil also has the name DCLXVI, 666, The Beast, another name for Crowley. He is the Prophet.

Rituals

Liber Viarum Viae assigns “The Protection of the Sphere” and *Liber O* to this path. *Liber O* is assigned to two other paths as well. That text lists three important practices for all forms of ceremonial magick: 1) assumption of God-forms; 2) Vibration of Divine Names, and 3) Rituals of Banishing and Invoking. Protection best fits section IV, that includes the pentagram and hexagram rituals. Together as 5 + 6 these symbols also advance the idea of union.

The ritual of *Troa* describes the candidate as, “He is weak and cowardly,” In *Pyramidos* the initiate expresses it as “I am a weakling and a coward. I cringe.”

X. The Hermit, Atu IX. Yod (⋄), ☿.

Other name: The Old Man

9. Also the Priest veiled himself, lest his glory be profaned, lest his word be lost in the multitude.

The **Priest** is the Hermit, protecting the LVX, while bringing this light to the world. Exposed in an unlimited fashion, the light would drown out everything with its brilliance.

The key element of this path is his **glory**, the **word**. It is the guiding light emanating from the Lamp of the Hermit. It is analogous to the fire hidden in the wand brought to earth by Prometheus. It is the genetic message in the spermatozoon transmitted by the phallus. It is the energy of the Sun. Like everything good, it comes to be expected and not appreciated. Therefore, its extension requires restriction.

The Hermit was the leader of the initiate in the Golden Dawn rituals. He carried a lamp of office. His lamp symbolized the hidden knowledge. His wand was the symbol of the directing power of that Knowledge. He is the Kerux for the path of Kaph, below.

The Book of Thoth reminds us that the letter Yod is the foundation of all other letters of the Hebrew alphabet. It is the first letter of Tetragrammaton. It symbolizes the Father (who is Wisdom), the Logos (who is a form of Mercury) and the Creator. The cognate symbol in physical life is the spermatozoon. The Hermit is looking at the Orphic Egg, the symbol of the latent universe. The snake, part of the symbol of the Orphic Egg, is Mercury, or the phallus. This is the creative and transformative essence of Life, the light of the universe.

Crowley summarizes this card with Yod \equiv Phallus \equiv Spermatozoon \equiv Hand \equiv Logos \equiv Virgin. There is perfect identity, not merely equivalence in the extremes, the manifestation and the method.

Sigils

The **Qliphothic Sigil** is inverse to the Mercuric one. The light or Word, represented by the cross, is turned inward and downward. The lamp is inverted. It represents ignorance or confusion, rather than chaos.

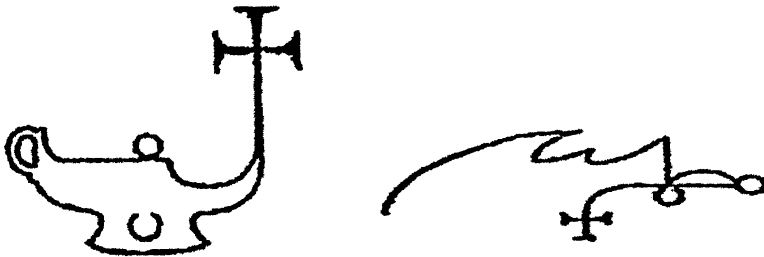

The **Mercuric Sigil** for Yod is among the easiest to interpret, probably because it is so classic. The hollow ancient lamp contains the light. The light symbolizes intelligence and spirit. The Cross ascending from the opening for the wick is the creative light, LVX. The Christian symbolism of this is Christ bringing light to the world.

Comparison to Path of Mem

The qliphothic sigils each suggest confusion or the need for reorganization.

The crosses in the Mercuric sigils indicate light.

Genii

Ichuvahaζanξθatan Yamatu

The name of the **Mercuric Genius** is **Ichuvahaζanξθatan**. It breaks down into several Greek components:

Ichuvah	Ichuvah	An alternate spelling of יהוה
aζ	Αστηρ	Star
an	αν	Not
ξ	ο	Origin, source
θatan	Θαταν	? Satan, the Light-bringer

This name indicates that the Star (= light) and IHVH, are not adversarial. The name is for the *Genius who brings true light to the world*.

The **Qliphothic Genius** name has three syllables. **Yamatu** characterize the path as the manifestation of generation on the material plane. Its Hebrew roots are:

Ya	יא	Manifests the potential faculties of things
ma	מא	Passive matter, water, an instrument of generative power and manifests it externally, mother
tu	טו	Determination, design, definition, all physical

The name of the genius says that *Yod is the mother of manifestation (letters, words)*.

Rituals

Liber Viarum Viae calls the path of Yod The Absorption of the Emanations. It attributes *Liber DCCCXI* to this path. *Energized Enthusiasm* is a ritual of

the Holy Grail. The text introduces the theurgy of sexual magic, and describes an occurrence of the ritual.

Liber 671 vel Troa, describes the candidate as: “He is lascivious and unthrifty.” In *Pyramidos*, the initiate says: “I am a catamite and a cunnilinge.”

X. The Wheel of Fortune, Atu X. Kaph (Ϛ), 4.

Other names: Fortune, Wheel, Le Roue de Fortune

**10. Now then the Father of all issued as a mighty wheel;
the Sphinx, and the dog-headed god, and Typhon,
were bound on his circumference.**

The Father of All is fate or Karma. This is a pattern of recurrence, of reincarnation, symbolized by the **Wheel of Fortune**. It is in continuous rotation. The three figures bound on the circumference represent forces that appear also on the Tarot card. The nature of the text is clear by comparison. The message says the universe is in a constant state of change, but stable. The **dog-headed god** is Hermanubis.

Sigils

The **Qliphothic Sigil** represents the balanced, but apparently non-moving Wheel of Fortune. The horns indicate a dark aspect of Fortune, but also fertility. Rotation has stopped and the gunas have fallen to the bottom. The four-armed cross symbolizes the lack of motion, or possibly Malkuth. It symbolizes stasis.

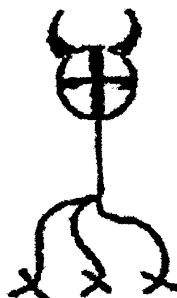
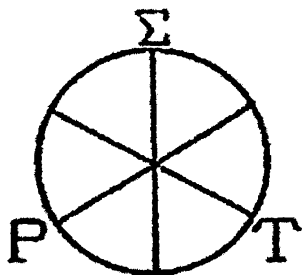

The **Mercuric Sigil** is a circle with three diameters representing the three axes of space. They reflect the tri-radiate nature of the universe with origin at the center. Three seems more symbolic than ten, as on the Thoth Tarot card. There, Crowley attributes ten to the sephiroth, and the attribution is to Malkuth.

The perimeter of the wheel expresses dynamic equilibrium — always turning, always the same. The important aspect of the gunas is movement. They cause the wheel to rotate. This is also true of the axle, but it is not so evident. They symbolize change in stability, and stability in change.

The three Greek letters represent three gunas: Σ is for Sattvas, P is for Rajas, and T for Tamas. Sattvas is calm, intelligence, lucidity. Rajas is energy, fire, brilliance. Tamas is darkness, inertia, or ignorance.

The Sphinx at the top of the wheel represents alchemical sulphur. Typhon on the right, moving down, represents Salt. Typhon (compare typhoon) also represents the destructive power and fury of nature. The destructive force of lightning also begets. Hermanubis on the left, moving up, represents the element Mercury, the connector.

The relationships among the gunas are characterized as follows:

Gunas	Rajas	Sattvas	Tamas
Creature	Sphinx	Hermanubis	Typhon
Force,	Active	Equilibrium	Passive
Characters	Energy	Calm	Sloth
	Excitement	Intelligence	Ignorance
	Brilliance	Lucidity	Darkness
	Restlessness	Balance	Inertia
Alchemy	Fire	Air	Water
	Sulphur	Mercury	Salt

At the axle in the middle all the spokes of the wheel become One, the Hadit point. The rim is also One—Nuit.

Comparison to Path of Vau

The gunas revolve like the whirling sun in Mercuric Vau. Life is dynamic.

Genii

Kerugunaviel Kurgasiox

The **Qliphothic Genius** is called **Kurgasiox**.

Kurg Κερξ An alternate spelling of Κερυξ. In the Golden Dawn system, the Kerux guards the inner side of the portal to the temple. He watches over the candidate, and leads all mystic circumambulations.

Asiox ασιας Asian, eastern (the “source of light” from of the darkness)

The name means the *Leader to the Dawn*.

The **Mercuric Genius** for the path is **Kerugunaviel**. There are three elements in the name as follows:

Kerug Κερξ Κερυξ, Keryx

guna γυνα Three Greek letters represent Rajas, Sattvas, and Tamas on the rim of the wheel, described above.

Aviel ’αviel Haniel, ַחַיִּיֵּל, the Archangel of Netzach (The English small letter v is sometimes a blind for the small Greek Nu (ν) in typeset text.) Haniel is a guardian of change or karma.

The name of the genius means *The Angel who guides fate*.

Rituals

Liber Viarum Viae lists the title as “The Evocation of the Mighty Ones.” A liber is not specified. This calling forth of the forces represented by the gunas refers to the forces of karma itself. Indeed, life itself is a ritual!

In *Liber 671 vel Troa*, the candidate is described as, “He is a glutton and a drunkard.” The corresponding statement in *Pyramidos* is “I am a glutton, a besotted wight.”

A ritual that directly relates to the action here is *Liber 675, Of the Ceremony of the King’s Chamber*. This is the fourth sub-section of the ritual. It includes what is called the Declaration of Innocence, or the Negative Confession. It takes place in the Hall of Maat. The process continues in the next path.

XI. Adjustment, Atu X. Lamed (𐤋), 𐤌.

Other names: Justice, Balance (Equilibrium)

11. Also the lady Maat with her feather and her sword abode to judge the righteous. For Fate was already established.

Berg (1990) discusses the cosmic energy-intelligence nature of the letter Lamed. The letter Lamed is the central force in the Universe. God and His Name are One. It is a name of God, 𐤋; it is also Not, 𐤌; and 𐤋 equals 𐤌. Lamed expresses balance and equilibrium, underlying symmetry, the Zero, the Ain (𐤀).

Without **Maat** life was impossible. Judges were priests of Maat. In the Hall of Judgment at the Weighing of the Heart, the heart of a deceased Egyptian was weighed against the feather of Maat, the symbol of Truth. Her two symbols are the **feather and the sword**. Her sword was two-edged to **judge the righteous** qualities of a man. The sword was the fulcrum of the scale, the point of balance. The **feather**, sensitive to the slightest movement of air, determined even the slightest variation from balance or truth. **Fate** is the karma that is symbolized by the previous path. It is completed before an individual enters the Hall of Maat.

In *The Book of Thoth*, Crowley called this path Adjustment. He changed it from its classic title, Justice, because he felt Justice had a human connotation and was relative. Since nature is exact, he considered justice not a fact of nature.

Historically, the path of Justice is Atu VIII in the Marseilles Tarot sequence. The number appears to have no further significance.

Some confusion about the change between the 8th and 11th Paths is

inherent in the word “coition.” Coition equals sexual union (= 8), but also implies duality and complementarity (= 11). The occult switch was made because magicians sensed the unsatisfactory match between the design of the card and its zodiacal attribution.

A name proposed here for this path is Equilibrium. It is homeostasis, the self-regulating internal adjustment of nature. Whether it be physiological processes, genetic processes, mountain building and erosion, or atomic structure, there is always change (following Kaph). For every action, there is an equal and opposite reaction.

Sigils

The **Qliphothic Sigil** shows imbalance. The pans of the scale are disturbed, the sword (fulcrum) has been displaced, the pans are disconnected, and the Word (Yod) is aside, away from balance.

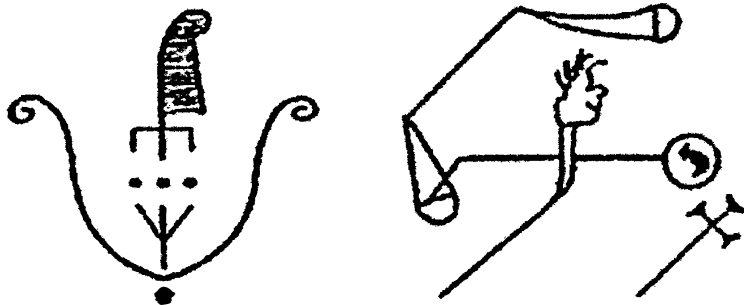

The **Mercuric Sigil** for Lamed is the Tree of Life with the Veils of Negative Existence. The Tree is inverted. The elements are symmetrically (naturally) arranged. It becomes a symbol of the gateway to Amennta — balanced and equilibrated.

The feather represents Truth, the key to the nature of this card. This is the indicator of the righteousness of the individual as he passes through the Hall of Maat. In the sigil it represents Assiah, Malkuth, the life of the individual that is under evaluation.

The next element is a horizontal line with three short verticals represents Lower Triad. The middle path of Samech is the arrow. The horizontal row of three dots represents the Middle Triad. The spaces above and below it

represent the Abyss. The three radiating lines represent the Light of Wisdom, from Atziluth to Briah in the Upper Triad. The single vertical line that extends from their juncture represents Atziluth

The large cup-like structure represents the Ain Soph that pervades the entire Tree. This sigil does not include Ain Soph Aur, Negative Existence. On the QT, Negative Existence is parallel, opposite, and complementary to the Tree itself.

The single dot at the bottom represents the Ain, Unity or Nothing, לא = אל.

The sigil symbolizes the positive aspect of both the TL and QT. It encompasses all. It is the sigil of God in the Universe, אלהים אשר ואהיה. It is reiterated in the Hebrew.

It is stated differently in *Liber DCCCXIII, Ararita I: 0*, which is taken from the Qu'ran Surah of Unity.

فل هو الله احد الله الصمد لم يلد ولم يولد ولم
يكن له كفوا احد

Qól: Húa Allahú achád; Allahú Assamád; lám yalíd walám yulád; walám yakún lahú kufwán achád.

O my God!
One is Thy Beginning!
One is Thy Spirit,
and Thy Permutation One!

Comparison the Path to Samech

The sigils for the paths of Samech are directly below those of Lamed in the tables.

The Qliphothic Sigil for Samech has a man suspended between two connected alternatives. On his right are the letters SKRZ (*Sanctum Kreuz*, possibly Christian Rosenkrenz). On his left is a Phoenix. Both sides imply a form of resurrection in process—and they are in balance.

The Mercuric sigils include the parts of the Tree of Life between Malkuth and the Middle Triad. See Samech, below.

Genii

Lusanaherandraton Lafcursiax

The **Qliphothic Genius** is called **Lafcursiax**.

Laf	<i>Λαφ</i>	Relates to gluttony
kurs	<i>κυρο</i>	Part of the verb <i>κυρωω</i> —to strike against, attain to, be master of
asiax	<i>ασιαζ</i>	Eastern (the revelation from the darkness).

The name means: *Excess is overuse, the opposite of balance.*

The **Mercuric Genius** for the Path is **Lusanaherandraton**. Its elements are:

Lusana	A combination of the Greek verb <i>λυω</i> meaning to loosen, destroy or abolish; plus <i>αναις</i> , meaning distress or sadness.
Anahera	A transliteration of <i>ανααιρω</i> . It means to lift, raise, or to carry off.
eran	Either from <i>ηρανοσ</i> meaning lovely or pleasant, or from <i>ηρανοσ</i> meaning a kindness or service, or, more particularly a club or society.
andr	The root form for <i>ανηρ</i> meaning man.
aton	Without exertion.

The collective meaning of the sequence of syllables then is: *The Genius to abolish distress and raise the civilization of man.* This is the natural result of equilibrium or homeostasis in the universe.

Rituals

Liber Viarum Viæ entitles the path, “The Passing of the Hall of the Balances.” It attributes to *Liber XXX, Liber Librae, The Book of Balances*, to balance.

The ritual *Troa* describes the candidate as, “He is unjust and unbalanced.” In *Pyramidos*, the initiate says, “I am a satyr and a sodomite.”

XII. The Hanged Man, Atu XI. Ma'im (𐌆), ▽.

Other names: Le Pendu, Traitor

**12. Then the holy one appeared in the great water of the North;
as a golden dawn did he appear,
bringing benediction to the fallen universe.**

The text for this path suggests that the **Holy One**, the “Hanged Man” is Ra-Hoor-Khuit. He comes from the darkness of midnight (**from the North** = Hoor-Paar-Kraat, the Light in Darkness, Khephra). He takes his seat in the East (the **golden dawn**) and becomes the **beneficent Initiator of the Æon of the Child**. See *Liber XXXI I*: page 13 (verse 49). The symbolism is different from the Hanged Man as the sacrificial god in the previous æon. Initiation is stressed over sacrifice.

The Book of Thoth attributes the traditional assignment of Mem to water. It refers especially to its spiritual aspect in initiation. Initiation is a baptism which is sacramental rebirth, hence the Hanged Man symbolism. Crowley continued that adepts of the INRI-IAO formula invented the Hanged Man in the Æon of Isis.

The path is not a symbol of sacrifice in the current æon. Crowley writes:

If ever things get bad like that again, in the new Dark Ages which appear to threaten, this is the way to put things right. But if things have to be put right, it shows that they are very wrong. It should be the chiefest aim of the wise to rid mankind of the insolence of self-sacrifice, of the calamity of chastity; faith must be slain by certainty, and chastity by ecstasy... Redemption is a bad word; it implies a debt.

Sigils

The **Qliphothic Sigil** for Mem looks like a rain cloud with a face at the top and five—or is it six—points of rain descending. The right one is double. The NVH is a transliteration of Hebrew נח, the name of Noah. The arrow is a symbol for the deluge, and the rainbow to follow. It represents the promise of God to Noah, This is a case of selection or purification by water. It represents a baptism of the earth with selected survivors. The whole sigil is

a glyph of water in excess.

The idea of excess is expressed by the overabundance of water, producing the Deluge. The cloud, God, is pouring water on the earth. The world was sacrificed in the flood. Noah and his family survived in the ark. The Flood can also be seen as an analogue of the change of æons.

The water comes from the North, the darkness, indicated by the arrow. The light ultimately replaces it.

NVH, or נב, has a value of 61, Nothing. There had to be destruction before the earth could flourish again. Imbalance and overabundance had produced the need for rebirth. The value of Mem is 40, the number of days and nights of rain.

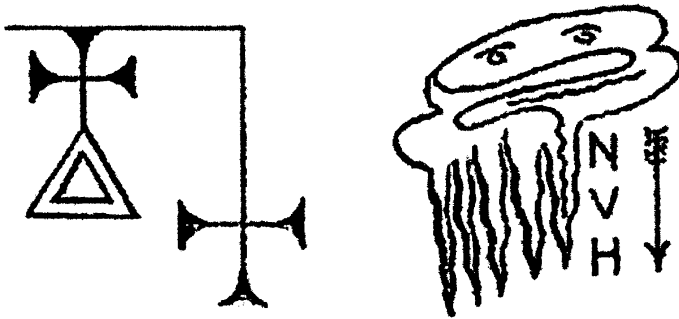

In the **Mercuric Sigil** for Mem the cross and triangle, is the symbol of the Golden Dawn.

The large scaffold may be the same as in the qliphothic sigil for Daleth. If so, it symbolizes a gate, a renewal, the opening to the New Æon, or personal initiation. As a sword, it is the symbol of discriminations (as in the path of Lamed).

The Hanged Man is the symbol on the altar during the Neophyte Grade of the Golden Dawn Order. Cicero and Cicero (1992) say: “the true symbol of the Order is the red cross above the White Triangle.” They act as the nucleus during the ceremony, and attract the Divine Forces into manifestation. It includes the message (initiation secrets) and the messenger (Initiator).

The Golden Dawn symbol in this sigil represents Ra-Hoor-Khuit, the bringer of light. He is the Lord initiator of the Æon—but in his secret name and splendour. His message is *The Book of the Law*, whose ultimate stated authority is Hoor-Paar-Kraat, the Silent Child. Together, as Heru-Ra-Ha,

both make initiation possible.

Comparison to Path of Samech

The Mercuric Sigil of Mem and the Qliphothic Sigil of Samech have a “Hanged Man,” signifying an initiation and renewal.

After the Deluge of the Qliphothic Mem, comes the promise (rainbow) of renewal in the Mercuric Sigil of Samech.

Genii

Malai Malkunofat

The Qliphothic Genius for Mem is **Mulkunofat**.

Mu	מ	Water, fluidity
Mul	מל	Continuity, plenitude, that which is full and entirely formed
kun	קון	Every difficult and painful action; all proper and particular existences, trial
o	ע	That which is crooked, false, bad
fat	פת	Space, a fool or simpleton, deceiving

The sense of the name of the genius means *The lamentation for the weakened kingdom*. That kingdom is the earth. The name also indicates the *Water purifies the world*.

The **Mercuric Sigil** is **Malai**. The Latin equivalent is **malae**. It means *protection or care*, possibly through sacrifice. It is symbolized by water, and by the pelican.

Rituals

Liber Viarum Viæ attributes the path of Mem to “The Sleep of Siloam” and the ritual in *Liber CDLI vel Siloam*. This unpublished ritual invokes each element, planet, and zodiacal and alphabetic forces.

The ritual *Troa* describes the candidate as, “He is changeable and selfish.” In *Pyramidos*, the initiate says, “I am as changeful and selfish as the sea.” Both express fluidity.

XIII. Death, Atu XII. Nun (𐤊), 𐤎.

Other name: Le Morte

**13. Also Asar was hidden in Amennti;
and the Lords of Time swept over him with the sickle of death.**

Note the similarity here between the phrase **Also Asar was hidden in Amennti** and the sub title of *Liber CCXXXI Quas vidit Asar in Amennti*. Osiris (Asar) is the Lord of Death. In Egypt, he ruled *Amennti*, the abode of the dead. The **Lords of Time** are Saturn and Chronos, Father Time, or the Grim Reaper, who sweep away the old, as at the New Year.

Asar holds the **sickle (scythe) of death** as a harvesting device. He is the Grim Reaper who brings death to individuals. Yet the secret of death is only that without it there can be no renewal. So, the underlying principle is not finality, but cyclical renewal by death and rebirth.

The mystery cycle begins with conception, resurrection. It ends with death and annihilation. This can be found in the cycle of seasons, the cycles of the moon, the daily cycle of the sun, and the course of initiation

Sigils

The **Qliphothic Sigil** uses the symbols of the skeleton and the scythe—Saturnine symbols. The skeleton wears the crown of Osiris. The scythe creates whirlings of regenerating forms. Compare them to the whirlings in the paths of Aleph and Tzaddi. At the tip of the scythe is the symbol of the Rose Cross, indicating regeneration to follow.

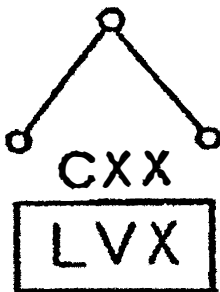

The **Mercuric Sigil** for the path of Nun has LVX in a rectangle, representing the tomb of Christian Rosenkreutz in the vault. The three circles connected by two lines represents the Vault. Another interpretation suggests the figure of Nuit as Maat, as on the Stele of Revealing. Then the tomb below becomes Hadit, or the Initiate under the shadow of the wings.

Above the sarcophagus is CXX. The number symbolizes the word ךע, ON, the Sun, the source of the Light. The number is the number of years before the opening of the tomb (the rectangle) of Christian Rosenkreutz.

The symbol is analogous to the process of pupation, the stage at which a caterpillar transforms into a butterfly.

All interpretations contain the idea of division and death—with the expectation of rebirth.

Comparison to Path of Shin

The tomb also occurs in the qliphothic sigil for Shin. There, it bears the motto “Non Patebo” (“I will not be revealed”—for 120 years). It is burial with the expectation of transformation to an afterlife.

Genii

Nadimraphoroiozεθalai Niantiel

The **Qliphothic Genius** is named **Niantiel**. The name breaks down as follows:

Ni	י	Bond connecting being and nothingness
an	א	Ain, Nothing
nt	ת	Parceling out
iel	אל	Suffix indicating an angel

Its meaning suggests the *Angel of youth and nothingness, i.e., renewal*.

The **Mercuric Genius** is **Nadimraphoroiozεθalai**. Its name contains several elements relating to Death, as follows:

Na	נא	Youth, freshness
di	די	That which is fecund, fertile, satisfies
m	מ	A collective sign, developing the being in infinite space.
raph	רפ	Idea of regenerating movement.
or	ער	Blindness, passion, exciting fire
oi	עו	Growth, material development
oz	עז	Hard persistent, support that which enjoys great generative vigor.
o		Letter of the void, also false, perverse, bad
thalai	טל	That which raises itself above another thing, covers, veils, or puts it under shelter.

The message of this name, then, is the *Genius who covers regeneration (i.e., during transformation)*.

Rituals

Liber Viarum Vie attributes the path of Nun to “The Preparation of the Corpse for the Tomb” and the ritual in *Liber XXV, The Star Ruby*. It starts with a banishing and then defines the generative force for the initiate.

In *Liber 671 vel Troa*, the candidate is characterized as, “He is vindictive and capricious.” The corresponding statement in *Pyramidos* is “I am a thing of vice and vanity.”

XIV. Art, Atu XIII. Samech (ס), ✠.

Other name: Temperance

**14. And a mighty angel appeared as a woman,
pouring vials of woe upon the flames,
lighting the pure stream with her brand of cursing.
And the iniquity was very great.**

The **angel** is casting a spell. She is mixing **vials of woe** together, either from one to another vessel into a fiery cauldron. She is blending extremes.

Blending or compromise as an aspect of temperance. The **iniquity** is great injustice or immorality.

The text for Samech shares much of the symbolism with the Thoth Tarot card. The path is key to understanding the Tree of Life. It connects Tiphareth and Yesod.

Historically, it is the central path, the prop on the TL. On the QT, it assumes a double nature. It always connects to Da'ath, Knowledge. *Liber LXV* I: 9 – 10 includes the following:

Debate not of the image, saying Beyond! Beyond!

One mounteth unto the Crown by the moon and by the Sun, and by **the arrow**, and by the Foundation, and by the dark home of the stars from the black earth.

Not otherwise may ye reach unto the Smooth Point.

Sigils

The **Qliphothic Sigil** has a central Hanged Man. This is the symbol of a man, not an abstraction. He is the Initiate, rather than RHK. He hangs from a frame showing transformation and rebirth. On the right is SKRZ, or Holy Cross, or possibly Rosenkreutz, meaning transformation. On the left is the rising Phoenix, signifying rebirth. Initiation is cyclical.

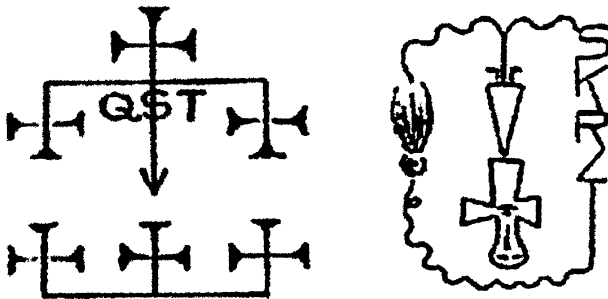

The **Mercuric Sigil** is an inverted diagram of the TL from Malkuth to the Middle Triad. Malkuth is the appendage. The QST, קשט, the rainbow, indicates the paths from the Lower Triad to Malkuth. The arrow of the Middle Pillar indicates the path of Samech. The verse from *Liber LXV*, above, applies here. It is all below the Abyss.

Comparison to Path of Za'in

The path of Za'in and Art (path of Samech) have a similar double nature.

Genii

Salaθlala-amrodnaθxiZ Saksaksalim

The name of the **Qliphothic Genius** is **Saksaksalim**.

Sak	סכ	The action of turning, circumventing. It also implies turning upside down (see the sigils!).
sulam	סלם	Ladder used in this context of Jacob's dream of the angels is Sulam. The path of Samech moves up and down the QT.
im	ימ	Plural ending

These *Angels that ascend and descend*. They connect Heaven and Earth, or Briah and Yetzirah.

The **Mercuric Genius**, **Salaθlala-amrodnaθxiZ**, has a two-part name.

The first part of the name of the Genius is:

Sal	סל	Every kind of movement with raises or takes away.
at	את	Sympathy and reciprocity
lala	לאלא	Extensive movement being opposed to itself, circular movement.

The second part begins after the hyphen.

Am	אמ	Mother, origin, source, nation, rule
rod	רד	Sign of movement; every indefinite movement, as of a wheel.
nat	נט	Produced existence united to that of resistance and protection. Inflection, offshoot, twining scepter.
oiz	עז	Designation for a genius.

The name describes the action of *the Angels as in Jacob's dream*. They move between heaven and earth.

Rituals

Liber Viarum Viae entitles this “Skrying in the Spirit Vision: the Ladder of Jacob.” It lists *Liber O*, more particularly to sections V and VI, rising on the planes. It reflects the action of Jacob and his Dream of the Ladder with Angels ascending and descending (*Genesis* 28: 10-19).

In the ritual *Troa*, the character of the candidate is stated as: “He is intemperate and vacillating.” In *Pyramidos*, the initiate declares, “I am most violent and I vacillate.” They both emphasize temperance, the earlier title for the path.

XV. Devil, Atu XIV. A'in (♁), ♁♁.

Other names: Le Diablo, El Diablo, (proposed: Horus/Set)

15. Then the Lord Khem arose, He who is holy among the highest, and set up his crowned staff for to redeem the universe.

This is the only path that has different connections on the TL and the QT. On the traditional TL it connects Tiphareth to Hod. On the QT it connects as a counterpillar from Chesed to Hod. If the TL were viewed in 3-d, the upper part of the path then would be behind the path of Yod. The paradigm shift comes with the arrival of the Æon of the Child.

The symbolism of the text can be interpreted first from Crowley's description of the Thoth Tarot card. The central figure is the Goat. It has an eye on its forehead and the helical horns reflecting the nature of the Universe. The eye, A'in (♁), signifies the path. Capricorn (♁♁), the horned goat upon the **highest** places of the earth represents creative energy in its most material form. The **crowned staff** is the TL.

In *The Book of Thoth*, Crowley wrote that the Goat represents Pan Pangenetor, the All-begetter, Creative energy. This energy is “veiled in the symbol of the Wand of the Chief Adept, crowned with the winged globe and the twin serpents of Horus and Osiris (? Set).”

In the text of *Liber CCXXXI*, the **Lord Khem** is the dark Lord. Set, a member of the Ennead. He is the god who rules the hot desert of southern Egypt. He becomes associated with the Devil, evil and extreme places.

The message of this path in this Æon relates to Horus/Set. Te Velde (1977) provides a detailed history of *Set: God of Confusion*. The traditional interpretation from the religious texts describes the war between Horus and his uncle Set as a power struggle.

The secular texts, he says, show that Set raped Horus, thereby losing his creative force and the “eye of Horus” was blinded and wept. This scenario fits well the message of the path.

There may be a pun in the last line, where *set* (i.e., Seth) and *up his crowned staff* (i.e., in sexual action) redeems the Universe!

Sigils

The **Qliphothic Sigil** has two parts and four letters.

The upper right face shows the blind Horus. The left side shows a set of male genitals of the ejaculated or emasculated Set. The two are connected, but separate.

The words for blind and eye both begin with A'in.

עור	ovr	Blind
עין	oin	Eye

The letters tell a supporting story. The pairs symbolize ejaculation. It supports Te Velde's interpretation of the Horus/Set relationship:

- BK ב כ Liquefaction, fluxion, resulting from a forceful grasp, flowing, weeping; every fluid accruing from contraction.
- RN ר נ Sound that follows a commotion.

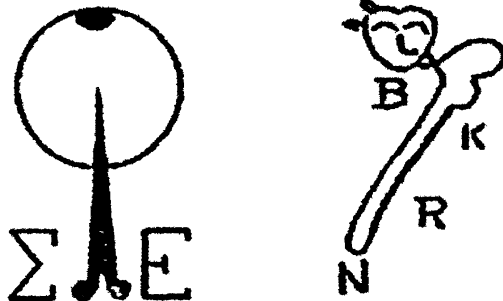

The **Mercuric Sigil** for A'in has a similar design as the Thoth Tarot card. It shows the more traditional interpretation of the path.

At the bottom are the Greek letters Σ and Ε, for Wisdom (Σοφία = Sophia) and Love (Ερως = Eros), respectively. These forces are Hod and Netzach, intellect and emotion.

From between these two letters extends a strong, pointed vertical erect phallus. The testes are below. The large circle at the top of the phallus is the crown, the yoni. The dot at the top is the seed through which comes renewal. Berg (1988, II: 127) says, that this is why the qabalist believes it is essential to understand the totality of nature and always to return to the source. The seed represents potential unfolding of the future. *In toto*, this is the crowned staff.

Comparison to Path of Peh

The message of A'in contrasts good and evil. The path of Peh shows destruction prior to/at initiation. The sigils do not appear related, but on the Tarot atu, the Tower shoots out either yods (seed) or individuals from its top. It is *Solve* of *Solve et Coagula*.

Genii

Oaoaaaooox-iZ A'ano'nin

The **Qliphothic Genius** is **A'ano'nin**.

A'	ע	Void or nothingness
an	אנ	Pain, sorrow, calamity, sphere of moral activity
o'n	ענ	Material void embodied, obscure, dark
in	ין	Universal manifestation

The name of the genius means *Nothingness becomes manifest*.

The **Mercuric Genius** for A'in is **Oaoaaaooox-iZ**. The nature of this word is like יהוה. It may be unpronounceable. It has few consonantal sounds, except the final designation at the end.

- Oa** Oa O and 1 with all they imply as equal and opposite. The name indicates the relationship between the Nothing and the All. It symbolizes the Gnostic Duality, the Dark and the Light.
- aaa** aaa Occurs in other names. There it is 111, The Fool, or Kether. It has the connotation of Kether for defining God. The brilliant light behind the Veil of Isis.
- ooo** ooo Parallel to **aaa**, but indicates the Ain, γᾠ. It is the complement of the **O** and ε surrounding them. It is Nothing, it is dark (since dark came before the light. Here is the ultimate God, Nothing, as dark.
- iꜛ** its A form of the Threefold Name of a God or Goddess in Coptic.

The name expresses opposites — *Good and evil* or *Duality* in trifold form.

Rituals

Liber Viarum Viæ calls this path The Sabbath of the Adepts, and attributes *Liber CCCLXX*, *Liber A'ash vel Capricorni Pneumatici* to it.

The Gnarled Oak of God is the Tree of Life. It is the tree of the Tarot card. The liber describes the Lightning Flash and the Ain Soph. It emphasizes the black (= khem), sturdy, lonely, and extreme nature of the path. Verse 7 says:

Set is his holy covenant, that he shall display in the great day of M.A.A.T., that is being interpreted as the Master of the Temple of the A.'. A.', whose name is Truth.

and later in verses 17 and 18:

Now shalt thou adore me who am the Eye and the Tooth, the Goat of the Spirit, the Lord of Creation. I am the Eye in the Triangle, the Silver Star that ye adore.

I am Baphomet, that is the Eightfold Word that shall be equilibrated with the Three.

and still later in verses 28 and 29:

All things are sacred to me; no thing is sacred from me. For there is no holiness where I am not.

A'in is the Eye, the Goat, the Lord, while the Shin is the Tooth, the Spirit, Creation, and the Triangle. This emphasizes exceed and strive ever to more. There is a darkness about the path, symbolized by Saturn, Set. The result is Truth, or Nothing.

In *Troa*, the character of the candidate is described as, "He is blind and sensual." The corresponding statement in *Pyramidos* is, "I am a blind man and emasculate."

Both references support the interpretation of TeVelde about the Horus/Set relationship. They also emphasize the character of Set, the Dark Lord.

XVI. The Tower, Atu XV. Peh (𐎢), ♂.

Other names: The Blasted Tower, The House of God, La Maison Dieu

**16. He smote the towers of wailing;
he brake them in pieces in the fire of his anger,
so that he alone did escape from the ruin thereof.**

Freedom for the entire world comes through a word for redemption, delivery, פְּדוּת. Thus, according to Berg (1988), the power or force of redemption comes through Peh. Peh is the positive energy channel through which freedom will reign throughout the Universe. Cosmic order is assured.

He (The Lord Khem, the Black God) destroyed the **Towers of Wailing** (the World) through the Deluge. The action of the Lord is shown on the Thoth Tarot card. The Eye of Shiva represents the supernal force whose opening brings about the destruction of the Universe.

This path is assigned to Mars, symbolizing **fire** and destruction. The Tower itself is destroyed. The occupants are thrown down. The color and angular aspects within the card emphasize suddenness and totality of the destruction. Ultimate destruction leaves Nothing, The quotation from *Liber XXXI I*: page 17, 18 (verse 57):

Invoke me under my stars! Love is the
law, love under will. Nor let the fools
mistake love; for there are love and love.
There is the dove, and there is the serpent.
Choose ye well! He, my prophet, hath
chosen, knowing the law of the fortress
and the great mystery of the House of God.

The House of God is another name for this atu, The Tower. It represents any condition before its fall.

The Eye of Shiva at the top of the card is the dominant element. Immediately below and to the sides are the dove and the serpent. They often are interpreted to represent the Will to Live and the Will to Die, the feminine and masculine impulses respectively. These are opposites, but complementary. This is the eternal cycle.

Sigils

The **Qliphothic Sigil** has the form of a crenellated church or fortress. Around it are the letters MUNDUS DEUS, invoking the World of God. It could represent the Old Æon, or the world and its institutions. There is no sign of destruction.

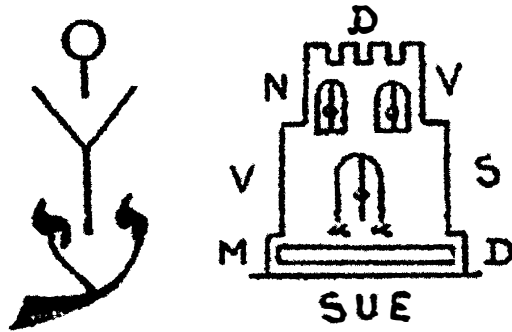

The **Mercuric Sigil** for Peh has three figures indicating paths of 70, 80 and 90—A'in, Peh and Tzaddi. Movement in the sigil is upward—division is cognate to destruction.

Set (the A'in, 70, at the bottom) is emphasized. Set or Shiva destroys world.

The split in the middle element represents Peh, 80, destruction. 80 is an inherent component of the initiation process of Abrahadabra—8 (Union, Holy Grail), 80 (Destruction before renewal), 418 (Reunion).

The upper element Koppa, 90, represents the path of Tzaddi, the regeneration or initiation to follow.

Comparison to Path of Qoph

The list of Hebrew letters compares Peh to Qoph. The comparison is reciprocal.

That Mercuric Sigil has an inverted Y. It is inverted compared to the Y in Peh. Following initiation, there is a reunion. It also has two towers, but they straddle the united path of the initiate and guide.

Together the paths of Peh and Qoph illustrate *Liber XXXI I*: page 7 (verse 30):

This is the creation of the world that
The pain of distance division is as nothing and
The joy of dissolution all.

Genii

Puraθmetai-αρηmetai Parfaxitas

The **Qliphothic Genius** for Peh is **Parfaxitas**.

Par	פַּר	Fertile, fecund, productive; progeny, or produce of any sort.
fax	פַּח	Diffusion, giving liberty, loosening
it	יֵט	Essence
as	שֵׂא	Fire in the absence of any substance.

The **Mercuric Genius** for Peh is **Puraθmetai-αρηmetai**. There are two elements to this name, separated by the hyphen. Each ends with **metai**.

Pura	Πυρα	Πυραθ. First is Πυργος, meaning a tower or fortification. Second is πυραιθω, meaning to light a watchfire. The root pur means fire, hence pyramid.
meta	μετα	means beyond or further. This combines with
ai	ἄιρω	Verb meaning to take by hand or force. Their combination means to go beyond.
αρη	αρη	αρης, Ares, or from αραιομαι, to pray to a god. It means a prayer for evil, a curse, or even mischief or ruin. It the Latin Dira, from which we get the English word <i>dire</i> .

The meaning of the name is “Light the fire at the Tower, let the curse begin.” Here is the destruction of the dross. It is a purification aspect in the initiatory process.

Rituals

Liber Viarum Viae refers to this path as “The Destruction of the House of God.” It refers to *Liber XVI*. In the *Official Instructions of the A.:. A.:.*, *Liber XVI Turris vel Domus Dei* refers to the Tarot at as the House of God. It describes attainment by the direct destruction of thoughts as they arise in the mind.

In the ritual *Troa*, the statement relating to Peh is, “He is angry and violent.” The corresponding statement in *Pyramidos* is, “I am a raging fire of wrath—no wiser.”

XVII. The Star, Atu XVI. Tzaddi (♁), ≈.

Other name: L’Etoile

17. Transformed, the holy virgin appeared as a fluidic fire, making her beauty into a thunderbolt.

The **holy virgin** is also the woman of the Tarot card—Nuit, the Lady of the Stars. She is Babalon or the Scarlet Woman at other levels. In her left hand, she holds a gold cup from which she **pours water on herself**. In her right hand is a silver cup that is emptying the water. The seven-pointed Star (symbol of initiation) of Babalon is in the upper left. The spirals indicate energy in the card. The card generally matches the quotation in *Liber VII vel Lapis Lazuli*, Chapter V: 5, where it says:

Only one fish-hook can draw me out; it is a woman kneeling by the bank of the stream. It is she that pours the bright dew over herself, and into the sand so that the river gushes forth.

Tzaddi is associated with righteousness and finality. The *Sepher Yetzirah* says that the Lord made Tzaddi king, and formed Aquarius in the universe. Fishhook is the meaning of Tzaddi. **Thunderbolt** is a cognate symbol. The text, the sigils, and the Tarot Atu resonate the initiatory nature of the path.

The fluidic fire attributes to the Waterbearer, ♒, the zodiac sign related to this path, The Star.

Sigils

The **Qliphothic Sigil** is a face with an elongate “hat,” forming a phallus-like structure. The dot at the top occurs in other sigils and signifies the seed. The overall impression is obsession, determination, Will. The expressions “you go to my head” or “brainwashing” apply—or “new awareness.”

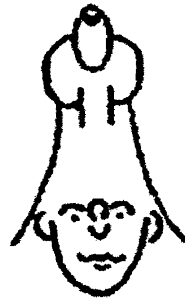
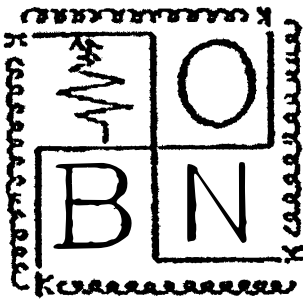

The **Mercuric Sigil** for Tzaddi is among the most detailed. It consists of a clockwise swastika. At each of the four points is a letter K for Kerub. Energy coils trail from them. It is a sigil of initiation.

The thunderbolt, in the upper left is the Lightning Flash, another glyph for Tzaddi.

the manifest force of the path. Three letters fill the other quadrants. They are B in the lower left, O in the upper right, and N in the lower right. The swastika as a whole represents the letter A, each arm an L. the letters are variously combined to produce words for degrees of initiation.

Comparison to the Path of Aleph

The table of comparison lists Aleph with Tzaddi. The letters can be blinds for one another. Each contains a swastika. Each expresses an aspect of initiation. Each symbolizes energy.

Genii

Xanθaζeranc-iζ [ε = sh, q] Tzufifu

The **Qliphothic Genius** is **Tzufifu**. Its name analyzes as follows:

- Tzu** צו A line drawn toward an end. It develops the idea of order, command, direction, impressed by the *primum mobile* (see Aleph).
- fli** פלי A sign of emphasis. Something wonderful, a mystery, a noble or magistrate.
- fu** פו That which is apparent, that strikes sight first.

The name indicates the genius as *one who is orderly, and impresses immediately*.

The **Mercuric Genius** is **Xanθaζeranc -iζ**.

- Xan** צאנ Face of things, mouth, beak
- tha** טא Resistance, rejection, repulsion
- st** שת Depth, foundation
- ir** יר Respect revere, venerate
- an** אנ Sphere of moral activity
- shq** שק That which acts through sympathy; that which is united
- iζ** Designator for a genius

By analysis, the name means he is the *Genius who respects righteousness and rejects the obvious*. Initiation is righteous, and rejects illusion.

Rituals

The reference in *Liber Viarum Viæ* for the path of Tzaddi is “The Adoration under the Starry Heaven” and the ritual *Liber XI vel NV*. This ritual uses Chapter I of *Liber XXXI* as a grimoire to create a high magick ritual.

Liber XC vel Tzaddi is a Class A liber giving an account of initiation. It indicates those who are suitable for initiation. Some of its verses are particularly enlightening in this regard:

8. But I bring you joy to your pleasure, peace to your languor, wisdom to your folly.
9. All that ye do is right, if so be that ye enjoy it.
15. I have hidden myself beneath a mask: I am a black and terrible God.
18. Only those who fear shall fail.
33. I reveal unto you a great mystery. Ye stand between the ABYSS of height and the ABYSS of depth.
34. In either awaits you a companion; and that Companion is Yourself.
35. Ye can have no other Companion.
40. My adepts stand upright; their head above the heavens; their feet below the hells.
42. Thus shall equilibrium become perfect. I will aid my disciples; as fast as they acquire this balanced power and joy so faster will I push them.
43. They shall be masters of majesty and might; they shall be beautiful and joyous; they shall be clothed with victory and splendour; they shall stand upon the firm foundation; the kingdom shall be theirs; yea, the kingdom shall be theirs. In the name of the Lord of Initiation. Amen.

The last verse shows the qabalistic nature of the path of the initiate, as expressed through the sequence of sephiroth of the Tree of Life. It compares to the end of Christian Lord's Prayer.

In the ritual *Troa*, the statement for this path reads, "He is a spendthrift and a miser." The corresponding statement in *Pyramidos* is, "I am a black-guard, spendthrift and a miser."

XVIII. The Moon, Atu XVII. Qoph (ק), ח.

Other name: La Lune

**18. By her spells she invoked the Scarab, the Lord Kheph-Ra,
so that the waters were cloven
and the illusion of the towers was destroyed.**

The **her** and **she** refer to the Holy Virgin of the previous path. **The Scarab** is a symbol of resurrection.

The **Lord Kheph-Ra** is the Sun at midnight. The image of Kheph-Ra relates to the Scarab, or dung beetle. The female rolls balls of dung into which she lays her eggs. When the eggs hatch they feed upon the dung, and the balls give the illusion of renewed life. By analogy, the balls symbolized the Sun that passed each night in Amennta.

The word **cleave** (past participle **cloven**) is distinct in English in being its own antonym. It is *Solve et Coagula*. The flowing water separates around an obstacle, and rejoins.

The path relates to Pisces, a watery sign, and the Moon. **The illusion of the towers** contrasts the finality of death to the reality of rebirth.

This path is assigned to Pisces. As the last sign in the zodiacal sequence it symbolizes endings. The next sign, Aries, is the sign of beginnings. Following this sequence implies renewal and rebirth—a gateway to rebirth. The action associated with the Vernal Equinox. It leads to Aries, the dawn of a new year. (In the western tradition, Easter is determined by the first full moon after the Vernal Equinox.)

Sigils

In the **Qliphothic Sigil**, the phases of the moon are grouped as 3 – 7 – 12, attributed to the elemental, planetary (double letter) and zodiacal (single letter) paths of the TL and the Hebrew alphabet. The sun at the bottom is the source of the reflected light. The light of the moon is illusion, and its phases continually change.



The **Mercuric Sigil** has a pattern similar to the Thoth Tarot card, which should be viewed for comparison.

The sigil can be viewed as a candidate going upward toward the dawn and becoming an initiate. It also can be viewed as the dawning of the New Æon. It is the sun on course passing from Pisces into Aries.

At the top center is the Sun emerging from the shadow of night—as suggested by the qliphothic sigil for Resh.

The united path is guarded by two Anubis figures. The jackals guard the re-united path. This is the opposite of the message of The Towers, which are no longer present. This tri-radiate central symbol brings together the division—Coagula.

The triangle, Δ , in the lower center is the symbol of change. The message of the sigil is the initiation of the candidate. He goes from illusion to reality.

Comparison to Path of Peh

The path of Peh symbolizes destruction or annihilation. The path of Qoph symbolizes the next stage, *i.e.*, heading toward the dawn of the New Æon. The central Y-shaped unit indicates division in the former, and union in the latter.

QaniAnayx-ipamai Qulielfi

The Qliphothic Genius is Qulielfi.

Qu	ק	Lightness, rapidity, velocity; attenuated, dark; without consistency
liel	ל	Night, the idea of circular motion, cycles, centripetal vs. centrifugal motion
fi	פ	The face of things, more manifest

The name reflects night and the Moon with its phases. It matches the Qliphothic sigil. The genius is *The Illusion of the Moon*.

The analysis of the **Mercuric Genius** follows:

Qani	Χαν	From χαινω, to speak, utter, pronounce
naux	ναυσ	The root meaning ship
nux	νυξ	Night. The two together are the gift of night.
ipamai	Επι+ημι	Means put in motion after, or follow

The name for the genius means *The gift of the night (Light in Extension)*.

Rituals

Liber Viarum Viae calls the path of Qoph “The Divining of Destiny.” It refers to *Liber CMXIII vel Viae Memoriae* (תישארב) to it. The A.: A.: Official Instructions indicate this is a method for attaining magical memory, or memory of past lives. It provides an insight into the function of the aspirant in his present life.

The statement in *Troa* is, “He is obscure and devious.” The corresponding statement in *Pyramidos* is, “I am obscure and devious and null.” They reiterate illusion.

XIX. The Sun, Atu XVIII. Resh (☿), ☉.

Other names: Le Soleil, El Sol

**19. Then the sun did appear unclouded,
and the mouth of Asi was on the mouth of Asar.**

Qoph and Resh maintain balance within the Light of Wisdom, so the cosmos does not fall into chaos. Resh accepted the role as an invisible intelligence behind the cosmic stage. Having the Light of Wisdom interacting with Resh and Qoph supports the western mystery tradition that the Light of Wisdom extends down the Tree as LVX.

In *The Book of Thoth*, Crowley considers this Tarot card one of the easier to interpret. It represents Heru-ra-ha in his manifestation as the Lord of the New Æon. He points out that the zodiac represents Nuit around the periphery of the design with Aries in natural position. He describes the zodiac as a differentiation and classification, a chosen belt, one girdle of Our Lady of Infinite Space.

The green mound is the fertile earth, bathed by the force of the Sun. The twin children, male and female, are innocent initiates. The butterfly wings symbolize their freedom.

Crowley continues that the wall completely encircles the mound of earth. This emphasizes that the formula of Rose+Cross is still valid in terrestrial matters. However, there is now an alliance with the celestial. The number 69 and the countered neters relate to the Holy Hexagram. The elaboration of these concepts occurs in *The Book of Lies*, Chapter 69.

The **sun did appear unclouded** represents the light of the new dawn, the Æon of the Child. The **mouth of Asi was on the mouth of Asar** indicates its cyclical nature.

Sigils

The **Qliphothic Sigil** shows the sun becoming exposed. This is the sun appearing at dawn, and initiation.

The lower central figure is very similar to the Qliphothic Sigil for Kaph. It indicates the lack of movement, the static nature of the Old Æon. The face is in Malkuth. The different lengths of the three legs suggest the paths of

Kaph, Samech and Mem, so it is below the Abyss. The upright neters are like the halves of the Mercuric Sigil of Gimel, and the gate of nature.

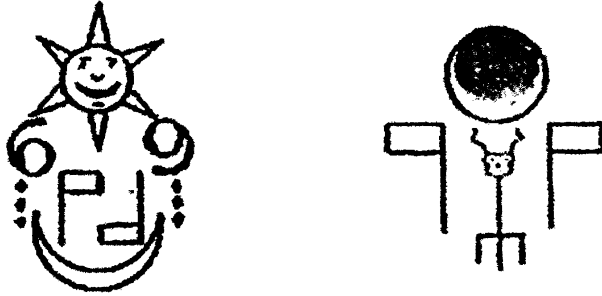

The **Mercuric Sigil** shows the beaming sun. Initiation has taken hold. The upper central sun is in full glory. The Sun above and the Moon below suggests the path of Samech. The 69 and the reciprocal neters suggest the phase shift of the path of Samech — 69 for Briah, the reciprocal neters for Yetzirah. The Æon is here! The rows of outside dots might indicate triads on the Tree. The initiate sees completion.

The more traditional interpretation is to relate the 69 and the neters to Chapter 69 in *The Book of Lies*.

Comparison to Path of Za'in

Comparisons between the sigils of Resh and Za'in are quite clear. Both show the 69 formula of cyclical change. Each has two rows of vertical dots associated with the neters. In Za'in they are under the flags. In Resh they are alongside the flags. The middle top and bottom Moon-Arrow/Star of Za'in are inverted compared to the Sun/Moon of Resh. This produces an intuitive feeling that the path of Za'in is more esoteric or reflective, while that of Resh is more open and material.

The Mercuric sigils are inverted relative to one another. The Sun now predominates. Reality has taken hold.

Genii

Ra-a-gioselahladnaimawa-iḥ Raflifu

The **Qliphothic Genius** is called **Raflifu**.

Raf	רפ	Regenerating movement
fl	פל	Something wonderful, precious, considered a mystery; a miracle; the man whom one reveres.
fu	פּוּ	Breath which comes from mouth, source

The name means *The sun is the source of the mystery of life*.

The **Mercuric Genius** is called Ra-a-gioselahladnaimawa-iḥ. The *selah* (שליח = messenger) provides evidence that the name derives from Hebrew.

Ra	רא	Movement, ray, visibility. He is the Egyptian Sun God. As a <i>double entendre</i> , the Hebrew רא means countenance. As רא it relates to vision, perception and sight, ultimately related to sunlight.
a	א	A transform element representing The Fool.
gio	גו	Life, convertible force
selah	סליח	Messenger
l	ל	Two possibilities. The first is as the preposition meaning to, into, for, or at. The second is as לא meaning not.
adnai	אדני	Lord.
mawa	מאוי	Desire.
iḥ	ist	Designation for the Genius.

The name of the Genius means *The Sun is the Lord of Initiation*. It is an analog of Ra-Hoor-Khuit.

Rituals

Liber Viarum Viae refers *Liber HHH* to the path of Resh. It calls it “The Illumination of the Sphere.” *Liber HHH* gives some methods for attainment through a willed series of thoughts.

The introduction to *Liber HHH* says there are two methods for knowing God—the Upright and the Averse (LVX and NOX). Let the mind become either a flame, or a well of still water. Initiation involves fire or water. This may bear on the arrangements of the neters in the sigil. The examples apply below the Abyss. They are reflections. In Chapter III, SSS, the initiate visualizes the brain as the Yoni and the spinal cord as the Lingam. The LVX passes through the spine in a practice of Raja Yoga. Union produces ecstasy.

Liber CC vel Helios (Resh) is a ritual of adoration to the Sun. It has four alternatives. They relate to the position of the sun at dawn, noon, sunset and midnight. Each version has four parts: Invocation, the Sign of Silence, the Adoration, and the Meditation. The object of the ritual occurs in verse 7:

Thus shalt thou ever be mindful of the Great Work which thou hast undertaken to perform, and thus shalt thou be strengthened to pursue it unto the attainment of the Stone of the Wise, the Summum Bonum, True Wisdom and Perfect Happiness.

In the ritual *Troa*, the candidate is described as, “He is dull and ungenerous.” The corresponding statement in *Pyramidos* is, “I am ungenerous and base and dull.” They express the opposite of the warmth and light of the Sun as the base of life.

XX. The Æon, Atu XIX. Shin (♁), △.

Other name: Last Judgment

**20. Then also the Pyramid was builded
so that the Initiation might be complete.**

The text describing the path is straightforward. The process of initiation stops here. The following path relates to the spread of Thelema to the Universe.

According to the *Sepher Yetzirah*, the Lord made Shin king over fire. He added a crown and combined one with another. With them He formed Heaven in the universe. After the Restriction (חיימוחום) positive energies had to be treated with compassion (Berg, 1988). The energy-intelligence of cosmic Shin was chosen for this, so the Kingdom could emerge as a harmonious entity. The way to control the dark aspect of consciousness was to envelop it with light.

The pyramid is one of the most classic symbols of initiation. *Πυραμς* has the same gematric value as *Φαλλος* or 671. Whether the pyramids of Egypt were burial sites, or as initiation sites, is immaterial here. Within the chamber of the pyramid, **the initiation took place**. The candidate was transformed into a new state. The pyramid is not the place of death, but of renewal. It is a place of pupation and transformation.

The Thoth Tarot card has no direct comparison to the sigil. Crowley points out that the old name for the atou was the Last Judgment. It had an angel blowing a trumpet to awaken the dead from their graves.

The Thoth Tarot card is an adaptation of the Stélé of Revealing. Nuit borders the left, top, and right margins of the card. Hadit is in the middle. The union of the two, Heru-Ra-Ha is a large, translucent figure also down the centerline. Crowley refers to the explanation of this relationship in *Liber XXXI*. He particularly mentions verse III: 72 referring to Ra-Hoor-Khuit:

I am the Lord of the Double Wand of Power
the wand of the Coph **Force of I Coph Nia – I** but
my left hand is empty, for I have crushed
an Universe + nought remains.

The Double Wand of Power, like the Double Horizon, symbolizes life (east, future) and death (west, past). Facing to the north, the gate of entrance, his left hand (west) is empty (Death). With final annihilation, the conclusion of the karmic cycle, nought remains.

In changing his name of the path from The Last Judgment to The Æon, Crowley recognizes a paradigm shift to the New Æon. It shifted from a final event aspect to one of expanded time.

Sigil

The **Qliphothic Sigil** represents the tomb of Rosenkreutz viewed from above. The words “Non patebo” mean “I will not open or be accessible or be manifest.” The tradition says it will last 120 years. A face suggests the eyes and mouth are making the statement. It is a prophecy. See the Mercuric Sigil for Nun.

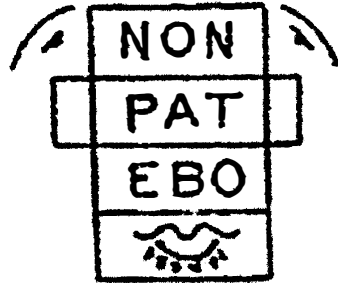
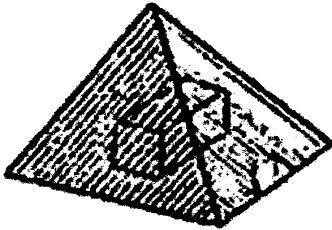

The **Mercuric Sigil** is diagrammatic of the Great Pyramid of Giza. This is the epitome of an initiatory temple. The pyramid has its entrance on the northern side, where initiation begins, symbolically at midnight. The internal chamber is oriented the same as the King’s Chamber—east to west, the double horizon.

Comparison to Path of Teth

There is no obvious similarity between the qliphothic sigils of Shin and Teth.

The Mercuric sigils, by contrast, are essentially the same. Teth is the 2-d representation of the 3-d pyramid in Shin. Teth has the wings of Nuit (= Babalon) over The Beast 666. Shin has the solid structure encompassing the initiatory chamber. The triangle with 666 compares to the chamber within, or the initiate. They are joined in the LASH TAL formula, where they represent Force and Fire.

Genii

Shabnax-odobor Shalicu

The name of the **Qliphothic Genius** is **Shalicu**.

Sha	שא	Movement related to power
li	ל	Restrained utterance
ku	כ	Restraining force, natural faculty which fetters the development of bodies and draws them back to their elements.

The **Mercuric Genius** for Shin is **Shabnax-odobor**.

Shab	שאב	Relates to Sabbath. Here it is rest, from the Hebrew שבת. It refers to rest or abstention from work, but may also refer to captivity and repatriation. It may be the rest of death.
nax	נאץ	Means to condemn or spurn. It is also a curse or insult.

The second part has three syllables:

od	עד	Eternity
ob	עב	To awake, or rouse oneself.

The name of this Genius means *Curse the rest (= death), rouse oneself for eternity*.

Rituals

Liber Viarum Viae entitles Shin “The Passage of the King’s Chamber.” It refers *Liber HHH* to it. It probably refers particularly to part II, AAA. In this section, the initiate ponders death by many means, and the gradual re-infusion of life to the corpse. Then the renewed reproductive power impregnates into the Egg, the disk of the sun. The sun sets, and passes through the blackness of night. It triumphs with the coming of dawn in the east. This is the period when the soul is entombed in the pyramid.

In a continuing sense, for the initiate whose paths incorporate the A.: A.: *Pyramidos* is the ritual between Probationer and Neophyte. An interpretation of the process may be the five sub-rituals indicated:

Of the Building of the Great Pyramid. The preparation of the Temple, and of the initiate for the ritual.

Of the Ceremony of the Grand Gallery. The Candidate seeks admission.

Of the Ceremony of the Threshold. The Candidate identifies himself with the Gods and presents his qualifications.

Of the Ceremony of the King's Chamber. The Candidate passes through the Hall of Maat for judgment.

Of the Sealing of the Great Pyramid. The success of the operation is symbolized in a sacrament of four elements. The temple is closed. The initiate announces his success.

The comment in the Declaration of Innocence in *Troa* ends with, "He is not marked with the flame." The corresponding statement in *Pyramidos* is, "I am not marked with the white Flame of Breath." He does not have the flame of initiation! This is true death—the initiate has achieved annihilation, as Hadit in union with Nuit.

The ritual *Liber V vel Reguli* ties together the Teth/Shin formula of LASH TAL. They represent Force and Fire respectively. In the ritual, the initiate aligns himself with the axis of the Macrocosm and Microcosm. Thereby, he accomplishes the Great Work in a different manner and employs the formula Abrahadabra.

XXI. The Universe, Atu XX. Tau (𐌛), 𐌛.

Other Name: The World

**21. And in the heart of the Sphinx danced the Lord Adonai,
in His garlands of roses and pearls making glad the con-
course of things;
yea, making glad the concourse of things.**

The first clause continues from Shin and the place of initiation. At Giza, the Sphinx, east of the pyramid, faces east and the rising sun. It unites the ideas of heaven and earth. When the **Lord dances** (= joins in action) Spirit unites

the four elements. Initiation is complete. The four powers of the Sphinx—to know, to will, to dare, and to be silent—are part of initiation. On the TL, *to know* can be assigned to Da'ath, *to will* to Binah, *to dare* to Chokmah, and *to be silent* to Kether. The dancing by the Lord Adonai in the chamber of the pyramid celebrates the successful initiation. Death conquers Life. Renewal results.

The I is the phallus containing the seed, pearls. The O is the Yoni. It is a classic symbol, represented by the rose. The **concourse** of these is the dew on the rose. The German word for dew is Tau.

The **rose** symbolizes completion and perfection according to Cirlot (1962). The **pearl** suggests a chosen one. It is a symbol of the mystic center and sublimation in man. It is a symbol of the human soul. The **garlands** therefore are symbolic of the successful process of initiation of the regenerated man. **Concourse** is the flowing together of the nature of God and the candidate in giving birth to the initiate. It is union. In Thelemic terms, the initiate has achieved the Great Work and Hadit—annihilation.

This is the final atu. With Aleph it spells \aleph , essence—beginning and the end. The end is Nothing in its complete expansion, which cannot be distinguished from Nothing. In *The Book of Thoth* Crowley adds:

The number 4, rather than the number 2, was chosen as the basis of this expansion, partly no doubt for convenience, to enlarge the 'universe of discourse,' partly to emphasize the idea of limitation.

This comment is the basis for exploring Tetragrammaton and the Cube of Four.

Sigils

The tripartite sigils of Tau are distinct in spanning the three columns of the previous paths. They are like the Tau of *Liber CD vel Tau*. In the latter, the letters are distributed in three rows of seven, rather than the seven rows of three as in *Liber CCXXXI*. They parallel the nature of the pillars to which they connect. The sigil for Tau reiterates the message of *Liber CD vel Tau*. The paths of Qoph and Shin are equilibrated in the Path of Tau.

The **Qliphothic Sigil** expresses duality, through which the Universe is comprehended. Each path shows contrast, which underlies all knowledge.

The left element is a turtle, symbolic of origin. The geomantic figure *Acquisitio*, gain, is on the carapace. It symbolizes the basis for increasing good fortune.

The middle element has two bars connected in series, but aligned in parallel. It separates the lateral elements.

The right hand element shows two complementary units—one with a connection to the middle, and one independent—like present and future. The past and the future influence the physical (scientific) and the metaphysical (religious).

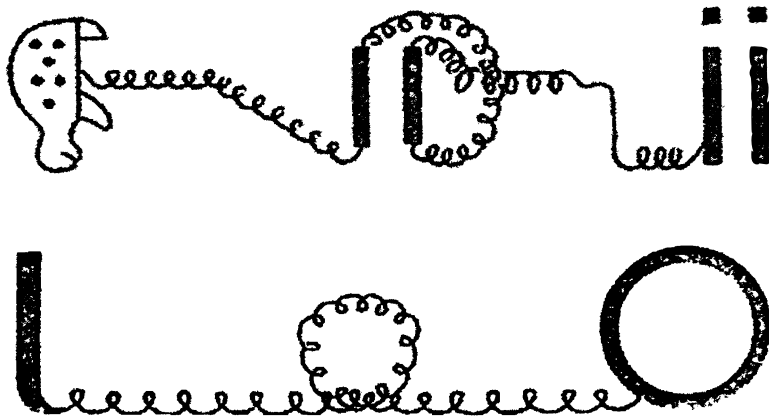

The **Mercuric Sigil** is singular in each of its three elements. The connection is direct and uniform. The I represents the active element, Hadit. The O represents the receptive element, Nuit. It is the formula of IAO. It is Duality returning to Unity

The I is the phallus containing the seed, pearls connecting to Hod. It holds the fire or seed of Shin. The O is the Yoni connecting to Netzach. The O is like Qoph, passive, watery. The middle is Tau, the transform that spans the pillars. Together they are QST, the Hebrew word for Rainbow, קשת, the promise of the future.

Together the two sigils show the return of the Two to the One. For the completion, the universe returns to the path of Beth, the Chaos from which duality arises in the Universal cycle.

Comparison to Path of Beth

The sigils do not compare readily, but the name of the **Mercuric Genius** has a direct connection.

Genii

Thath'th'thithξthuth-thiΞ Thantifaxath

The **Qliphothic Genius** for the path of Tau is **Thantifaxath**

Than	תן	Gift
ti	אן	Determination, definition, limits
fax	פצ	Confusion, giving liberty
ath	אח	Manifested, real, substantial

The Mercuric Genius is **Thath'th'thithξthuth-thiΞ**.

This name does not analyze as directly as previous ones into meaningful Greek or Hebrew roots. It is a vowel sequence between “th’s.” The *θ* relates to a form of the verb *τιθημι*. to put or place, to fix (the law), to institute or establish. The sequence of vowels is a-’ (probably an unaccented e) -’-i-o-u.

The name means *The gift of manifestation*.

The permutation of letters (vowels and consonants) is a form of meditation in qabalah. It is shown in the 231 gates, or two Hebrew latter combinations from which the number of this liber is derived. It symbolizes the creation of the world by what God said. This is a *Word for manifestation*.

Rituals

Liber Viarum Viae calls the path of Tau “The formulation of the Body of Light.” It assigns the rituals in *Liber O vel Manus et Sagittae* or *Liber VI* to this path.

Liber CD vel Tau is a graphic interpretation of the Tarot and initiation.

CHAPTER SIX — ALPHABETS
(HEBREW, GREEK AND ENGLISH)

The Book of the Law makes clear that the explanation of the Mystery of the Letters characterizes the English alphabet as kabalistic, and even alphanu-
meric.

Liber XXXI: II, 55 (pages 14-15) says:

35 Thou shalt obtain the order & value of
the English Alphabet; Thou shalt find
15
new symbols to attribute them unto.

In *Liber CCXX* Ch. II: 55, the published typeset interpretation is:

Thou shalt obtain the order & [+] value of
The English Alphabet; thou shalt find
new symbols to attribute them unto.

Aleister Crowley attributed the English letters to the trigrams of *Liber Trigrammaton* (Symonds & Grant, 1974). He was not satisfied. He depended largely on the sounds of the letters. Hebrew letters label the paths on the TL. Like Hebrew, English letters relate to paths, rather than the sephiroth.

The sequence in *The Riddle* found in *Liber AL*: II: 76 revealed a correlation between the Hebrew letters and paths on the 3-d QT. The letters of the Greek and English alphabets also correlate better to the paths. They follow the directive from *Liber XXXI* II: 74:

Aye! Listen to the numbers + the words.

This means consider sound, value and grouping.

Diringer (1968) wrote that the Aramaic script, including Hebrew, is a main branch of the North Semitic alphabet. The Greeks learned the art of writing from the Phœnicians, also of North Semitic origin. A major difference between the two is that the Hebrew alphabet technically does not have vowels. It uses non-letter points for vowel sounds. He said on page 358:

The order of the Greek letters corresponds, with a few understandable exceptions to the order of the Semitic letters (the order of the Greek letters is also evident from their numerical value).

He continued on page 419:

The Etruscan alphabet was the link between the Greek and the Latin.

This supports the hypothesis that the English (Latin) alphabet is closer to Greek than to Hebrew. Correlations among the three alphabets are found below:

		1	2	3	4	5	6	7	8	9	
Gr		Aa	Bβ	Γγ	Δδ	Εε	FF	Ζζ	Hη	Θθ	
Eng		A	B	G	D	E	U V F	Z	H Ch W	Ðð	
Heb		א	ב	ג	ד	ה	ו	ז	ח	ט	
		10	20	30	40	50	60	70	80	90	
Gr		Ιι	Κκ	Λλ	Μμ	Νν	Ξξ	Οο	Ππ		
Eng		I J Y	K	L	M	N	C X	O	P	Ts	
Heb		י	כ	ל	מ	נ	ס	פ	צ	ץ	
		90	100	200	300	400	500	600	700	800	900
Gr		Οο	Ρρ	Σσ	Ττ	Υυ	Φφ	Χχ	Ψψ	Ωω	λ
Eng		Q	R	S	T	U	F Ph	Ch	Ps	Ww	
		100	200	300	400	500	600	700	800	900	
Heb		פ	ק	ר	ש	ת	י	כ	ל		

The above chart of letters and numbers is based on a Greek Alphabet with 27 letters. The current Greek alphabet has 24. Three archaic letters have lost alphabetic use, but are retained as numbers. The three solely numeric Greek letters are Digamma Ϝ = 6 (2×3), Koppa Ϙ = 90 and Sampi Ϡ = 900). For mathematics and numbers, the Greeks now use Arabic numerals.

In his *Greek Kabbalah*, Barry (1999) includes information about the *Sepher Yetzirah*. His Tree of Life diagram is from *Magick, Book Four, Liber ABA* (1997) with the distinctive Crowley Heh/Tzaddi switch. The Teth/Lamed switch Tarot at numbers are not included.

English letters mostly follow the Greek/Hebrew sequence. The analogies are based primarily on sound. English has more sounds than letters, so duplicates occur. This is truer of vowels. Differences in pronunciation between stressed and unstressed consonantal sound are normally not recognized. The details are explained below.

The number for each of the letters and discussion follows. The index number is based on Greek alphanumerics.

Value Description

1. Alpha, $A\alpha$; Eng. Aa; Heb. א. Greek, English and Hebrew have a similar sound [a]. Greek and English letters are similar in form. In all three, this is the first letter in the alphabet.
2. Beta, $B\beta$; Eng. Bb, Heb. ב. Greek and English have the same basic form. While classic Greek may have had the sound of [b], Modern Greek gives it the sound [v]. The [b] sound is currently written as $\mu\pi$. In all three languages, the letter is second in sequence.
3. Gamma, $\Gamma\gamma$; Eng. Gg; Heb. ג. The sound [g] and position are similar in the three languages.
4. Delta, $\Delta\delta$; Eng. Dd; Heb. ד. The three languages have a similar sound, [d], in the fourth position.
5. Epsilon, $E\varepsilon$; Eng. Ee; Heb. ה. The most common letter in English is the vowel E. It represents several sounds, from short to long. The Hebrew letter analogue is Heh (ה).

Greek may use a smooth breathing mark (´) before a vowel. The rough breathing mark (´ε) over the ε indicates an [h] sound. Neither is considered a letter, and has no numerical value. Transliterated into English, the H sound can also be written He, as in Hru and Heru.

6. Digamma, FϜ; Eng. Vv; Heb. ך. This Greek letter indicates the guttural sound of soft [gg] (as in *haggard*) or [gh] (as in *rough* or *cough*). Its numerical value is 6, a double Gamma (= 2 × 3). The English letter F [f] is equivalent to the Greek Phi, φ. In *tough*, *though*, *through*. The [gh] sound has other expressions. The Latin F derives from the Digamma, but has the sound [f].

Two Gammas together are pronounced like [ng], as in singing. They have a value of 6.

In modern use, a Greek Stigma looks almost like a final Sigma (ς), Stigma (ς = 6) is a Greek ligature of στ. It dates from the 9th Century and became a ligature with the cursive form of the Digamma (F), the old symbol for 6.

Crowley used 6 for Ypsilon when discussing the formulas in *Liber V vel Reguli*. He relates the Hebrew Vau to the English U and V. In both Latin and English, the U is a vowel form of V. English W may belong here also.

7. Zeta, Ζζ; Eng. Zz; Heb. ם. The z for [z] occupies seventh place in the alphabetic sequence in Greek and Hebrew. This appears to be its original position, rather than at the end of the alphabet, as in English.
8. Eta, Ηη; Eng. Hh; Heb. ם. Its original name was Heta. The sound seems not so guttural, or rough breathing quality. In Greek, its original function indicated the consonant [h] from the Phœnician Heth. This is the long E in Greek, and the H of English. It does have a distinct sound in German, but has no single letter designation. It is pronounced back in the mouth, a guttural. The [ch] in German occurs in words like *licht* (= light), *nacht* (= night) and *nicht* (= not). Note the similarity between this and Digamma.

9. Theta, $\Theta\theta$, Eng. Th th; Old Eng. Eth, $\Ð\ð$; Heb. Θ . The sound of the Greek Theta occurs in the obsolete eighth English letter Eth ($\Ð, \ð$). Its old form was a circle with a dot inside. It occurs as a letter in Old English and Anglo-Saxon, and is still found in Icelandic and Faroese. It has the voiced sound of [th], as in *them*. It is also found in the same position in the Hebrew alphabet. In Modern English, [th] has two sounds. Compare the [th] in *think* and *them*. Some ambiguity occurs in transliterating Theta and Tau equivalents into English. The names of the Mercuric genii in *Liber 231* use Θ and T to distinguish the two sounds.
10. Iota, Ii ; Eng. Ii (consonantal form Jj, initial and final form Yy); Heb. י . Greek, English and Hebrew are equivalent [i] of Hebrew Yod. The Y is used most as an initial or final form of the short [i] sound.

The English letter J is a consonantal counterpart of I. In Latin, it sounds like [i], and is written that way, as *Iulius* = *Julius*. The [j] sound, as in *adjust*, represents the sound of the consonant.

20. Kappa, $K\kappa$; Eng. Kk; Heb. כ . The k, [k], sound is similar in all three languages, and has the same position in the sequence all three languages.

Several different letters symbolize variants of the [k] sound. The [ch], from [k], occurs in words like *church* (*kirk*), *cherub*, *Charles*. It can be confused with the Greek Xi (*character, charisma, chaos, chasm*).

30. Lambda, $\Lambda\lambda$; Eng. Ll; Heb. ל . The sounds of L, [l], are similar in all three languages. In English, the stressed and unstressed sounds occur in *little*.
40. Mu, $M\mu$; Eng. Mm; Heb. מ . The sounds of M, [m], are similar in all three languages.
50. Nu, $N\nu$; Eng. Nn; Heb. נ . The sound of N, [n] is similar in all three languages. The lower case Greek Nun looks like a lower case V in English.

60. Ksi, $\Xi\xi$; Eng. Cc; Heb. ס . This sequence correlates alphabetic Ksi ($\Xi\xi$) in Greek to Samech (ס) in Hebrew. The name has both [k] and [s] sounds. Hebrew Samech (ס) symbolizes only the [s] sound.

English is more varied. C can have the sound of [k] before a, o and u, as in *call*, *case*, *college*, and *custom*. It has the sound of [s] before e, i and y, as in *cell*, *cilia* and *cyan*. The c is silent in the combination ck [k] as in *back* and *lock*. Note the consonant shift between the singular *helix* and its plural *helices*.

The Greek KsI ($\Xi\xi$) can be confused with the Greek Chi ($\chi\chi$), related to the Latin X. If it sounds like [ks], it is likely Ksi

70. Omicron, *Oo*; Eng. Oo; Heb. ז ; value 70. This letter agrees in position between [n] and [p] in all three languages. A variation in the sound of [o], long and short, occurs in Omega. The A'in is usually transliterated as an O.
80. Pi, $\Pi\pi$; Eng. Pp; Heb. פ ; value 80. The sound of P [p] matches that of Pi in Greek and Peh in Hebrew. In Hebrew, it may take the sound of [f] as well, and may sound more like Phi (ϕ , [f]).
90. Tzaddi, Heb. צ ; Eng. Tz tz. This Hebrew letter has no Greek or English analog. The Hebrew Tzaddi (צ = [ts]) has a value 90.

The Hebrew letter Tzaddi (צ) is interpolated into the Hebrew alphabet between the equivalents of Greek Peh and Koppa, or English P and Q. Its “standard” transliterated form is X in English.

 The Glyph in *Liber XXXI* I: 57 and the Riddle in II: 76, complicates the situation. The Glyph is not found in any of the three alphabets. It is outside the set of “old letters” of the Hebrew alphabet, and not one of the final letterforms. It has a value of 90. Its sound is unspecified. The text of *Liber XXXI* implies it can be confused with Tzaddi.

90/100. Koppa, $\varrho\rho$; Eng. Qq/Heb., ק . value 100. The value of the Koppa (ϱ) is 90. An early name for the city of Corinth began with the letter Koppa. Modern Greek uses it only as a number. Etymologically, the English Q derives from it. It has the sound of a hard [k], as does the Hebrew Qoph, which has a numerical value of 100.

The table above shows the pattern for the numbers 80 and 200. Their shapes, sounds and values have a complex relationship, particularly evident among English P, Hebrew Qoph, and Greek Rho.

100/200. Rho, $P\rho$; Eng. Rr/Heb. ר . The Greek Rho has a value 100. Rho sounds like [r], but looks like the English P. Resh has the sound [r].

The English R has a similar shape to Greek Rho, P, and a value of 100. Hebrew Resh has a value 200.

200/300. Sigma, $\Sigma\sigma$; Eng. Ss/Heb. ש . The Greek Sigma and English S have the sound [s] and a value 200. Hebrew Shin has a value of 300. It has either an S, [s], or an Sh, [sh], sound.

300/400. Tau, $T\tau$; Eng. Tt /Heb. ט . The value of Greek Tau and the English T, with the sound [t], is 300. The Hebrew Tau has a value 400.

The Hebrew “old letters” alphabetical sequence of the pre-Babylonian Captivity (before 597 B.C.E.) ends with Tau. After the return from Babylon in 538 B.C.E., the Hebrews added five final letterforms—for Kaph, Mem, Nun, Peh and Tzaddi. The total number of letterforms becomes 27, the same as Greek. The sequences are mostly parallel.

The Hebrew final letterforms are independent of their old forms in shape and value, but they match in sound. In Hebrew gematria, final values are often ignored, and the sum uses the original letter values. They do not correlate to the Greek or English letters of corresponding value.

Neither the Greek nor Hebrew system has a zero. Fibonacci (1170 to ca. 1250) introduced the zero from Islam in the 12th Century. The Hindu-

Arabic number system, with the positional zero (= 0), goes back to the 9th Century. This method for calculation is easier than using the Greek or Hebrew number system, and has almost completely replaced it.

400/500. Upsilon, $\Upsilon\upsilon$; Eng. Uu;/Heb. ׀. The Greek letterforms look like the Y and u of English. The sound is [u] or [eu]. The English letter matches the Greek Upsilon in position following a T, [t], value and sound. Its value is 400. Kaph final has a value of 500. Crowley recognized the similarity to the Hebrew Vau, and used a value of 6 for U and V. He used this in analyzing the formulas in *Liber V vel Reguli*.

500/600. Phi $\Phi\phi$; Eng. Ff/Heb. ם. This is the Greek symbol for the sound [f]. Greek Phi has a value 500. The English F is either 500 or 6. See Digamma, above. The Hebrew Mem final, ם, has been displaced to 600.

600 / 700. Chi, Xx; Eng. Xx/Heb. ך. Several Greek letters have a sound [k]. The explosive sound of Greek Xi ($\chi\chi$) is hard [k]. In English it is spelled Ch in Greek cognates, as in *character* and *charisma*. Comparisons in sound should be made to Kappa, and even Ksi for some words.

The Latin letter X derives from the Greek Chi ($\chi\chi$), but its English sound is [ks]. Nun final is 700.

700/800. Psi, $\Psi\psi$; Eng. Ps ps/Heb. ף. No single English letter has the sound of the Greek Psi [ps]. The combination occurs in words of Greek origin, including *psalm*, *pseudo* and *psychology*. The [p] is usually not pronounced. The value in English is 700. The value of Peh final in Hebrew is 800. It does not have the [s] sound included in Hebrew. In English, the [p] sound is usually silent, even in words of Greek origin, such as *psychology*.

800/900. Omega, $\Omega\omega$; Eng. Ww/Heb. ן; value 800. The long [o] of Greek is the Omega. The Greek lower case Omega is similar to the shape of the English W. The two have the sound of a long [o] or [oo], much like [w] in English, so it may also relate to Cheth and 8.

The Omega has a value of 800. The value of the English W is 800 or 8. The Hebrew Tzaddi final is 900.

900. Sampi, ש; Eng (no letter); Heb. (no letter). Its archaic form is a variant of T. Its sound was a sibilant—possibly [ss] or [ts]. It occurs in Ionic Greek between the 6th and 5th Centuries B.C.E. It may be cognate to the Hebrew Peh final or Tzaddi final, also at the end of the alphabet.

Hebrew Alphabet on the QT

The letters after ט, T or Tau are less consistent than those before. The English U and V relate to Hebrew Vau, and occur on the path from Chokmah to Chesed. The path of the Glyph, from Geburah to Yesod, does not have an assigned letter in the other languages.

The path attributes for the “old letters” and the final letters are shown separately on the phases of the Quantum Tree. They include paths on the QT beyond those recognized on the TL.

The paths from Da’ath are in a separate figure. They connect to peripheral sephiroth at the Middle Triad. Hebrew final letterforms designate them.

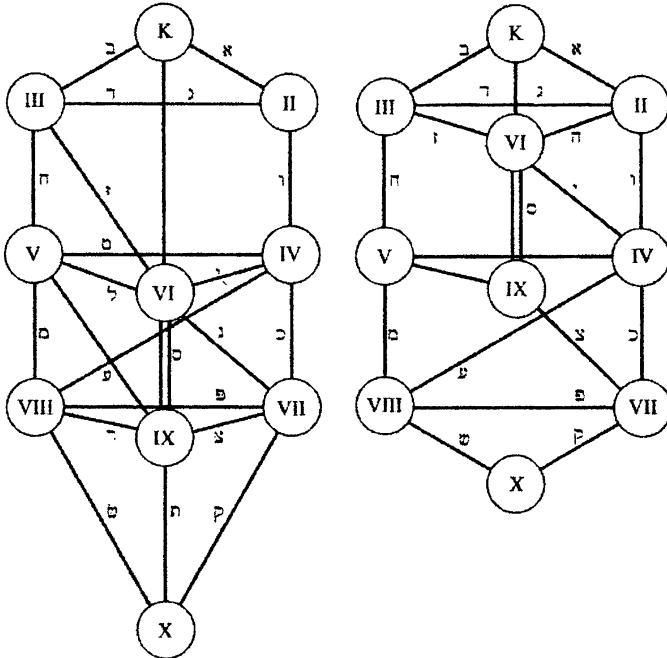

LOWER PHASE

UPPER PHASE

OLD HEBREW LETTERS ON QT PATHS

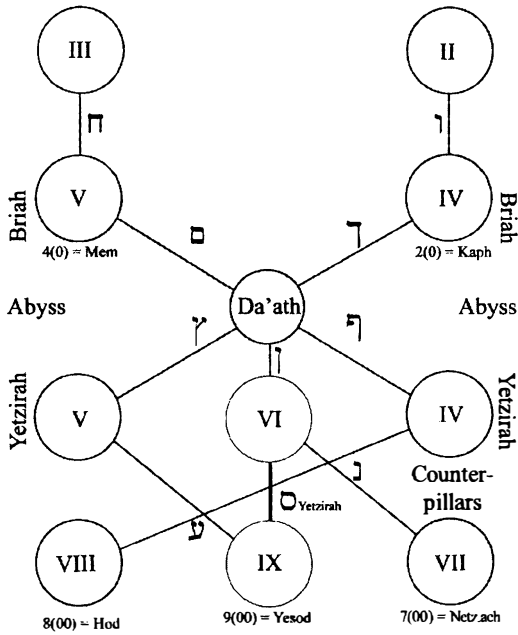

HEBREW FINAL LETTERS ON QT PATHS, LOWER PHASE

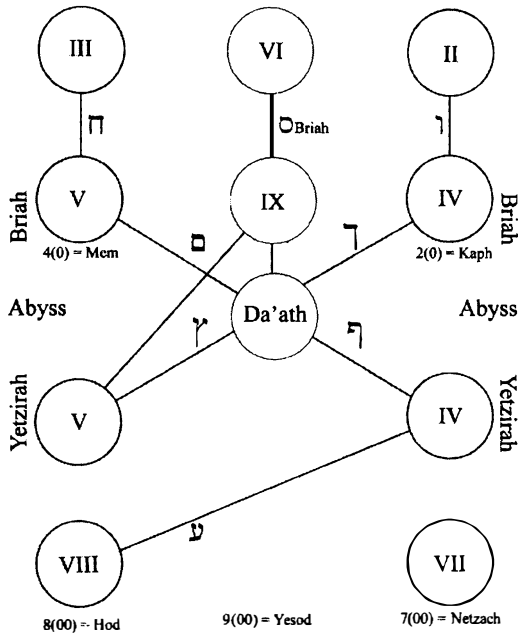

HEBREW FINAL LETTERS ON QT PATHS, UPPER PHASE

Greek Alphabet on the QT

Most of the letters are cognate with those of English, and lesser so with those of Hebrew. The path of the Glyph is included. Koppa and Chi are equated.

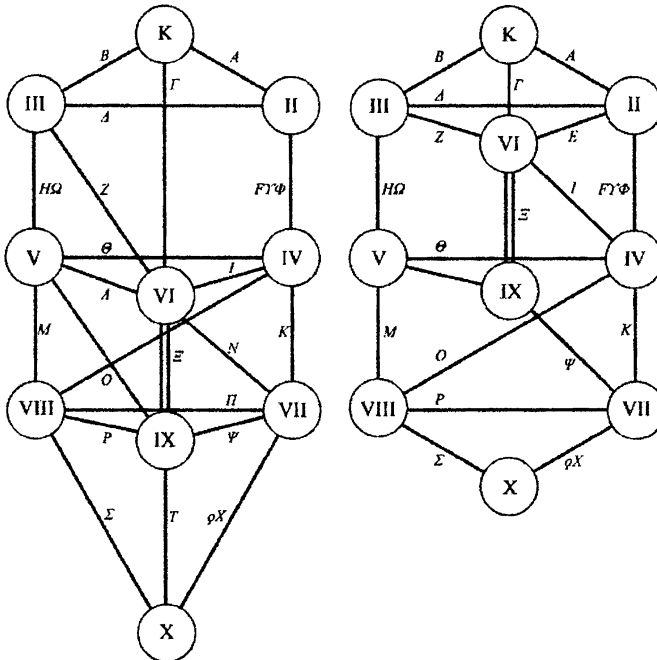

LOWER PHASE

UPPER PHASE

GREEK LETTERS ON QT PATHS

The Upsilon, $\Upsilon\upsilon$; Phi, $\Phi\phi$ and Digamma, $\Phi\bar{\rho}$, are correlated because of sound as U, V or F. They correlate to the path of Heh, with a value of 6

The Chi, $\chi\chi$, seems best related to the sound of Hebrew Cheth. The Greek Ksi, $\xi\xi$, is also transliterated as X, but has a different sound. In this place, its value is 8.

The Psi, $\Psi\psi$, is difficult to assign. The combination sound, [ps], does not fit any recognized position. The value is not established. It may relate to final Peh (פ) or final Tzaddi (צ).

The Omega, $\Omega\omega$, matches with the sound [ou]. It is assigned to the path from Binah to Geburah. By position on the QT, it also has a value of 8. This relates to its traditional value of 800.

The Zeta matches the position of Hebrew Za'in between Binah and Tiphareth. Its standard value is also 7.

English Alphabet on the QT

Most of the letters up to T are clearly parallel to those of the Hebrew alphabet.

The obsolete English letter Eth, Ð ð, matches the Greek Theta and Hebrew Teth in the alphabetic sequence of both the TL and QT. It occupies the path from Chesed to Geburah, and has a value of 9.

Those after, from U to Z, are found on the paths of the Upper and Middle Triads in Briah. They are shown in a separate figure below. The V, X and Z have cognates among the earlier consonants. The U, W and Y have some characteristics as consonants or vowel modifiers as well.

The paths cross the Abyss on the Golden Dawn TL. Their attributions are shown in Upper Phase.

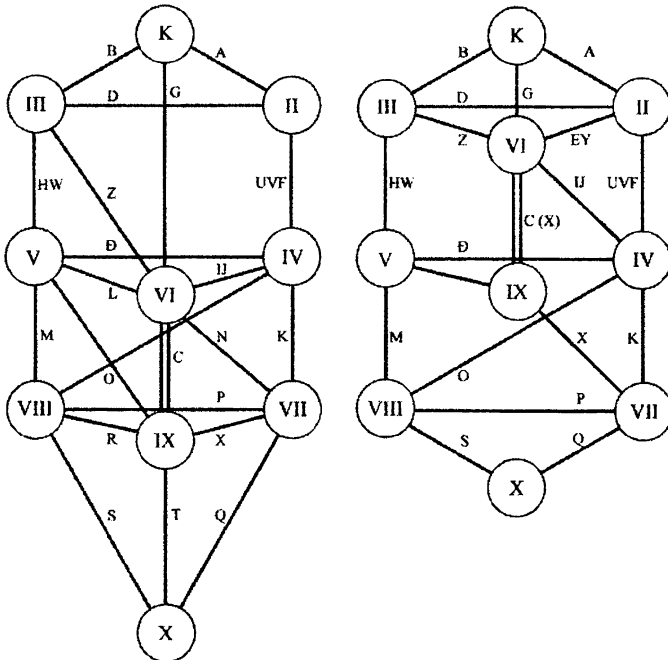

LOWER PHASE

UPPER PHASE

ENGLISH LETTERS ON QT PATHS

The unlabeled path of the Glyph, from Geburah to Yesod occurs in both phases.

The path from Chokmah to Chesed includes the vowel U, its consonant form V, and unvoiced consonant F (also Digamma). It has a value of 6. In defense of the formula AUMGN in *Liber Reguli*, Crowley (1976) used the U as 6.

The W seems to relate best to the [ou]. It pairs with the [gh] sound of Cheth to form the variably pronounced [ough]. Then it has a value of 8. It may be comparable to the double U of the path between Chokmah and Chesed, with a value of 6. This needs further research.

The X has the sound [ks] of the Greek letter Ξξ, attributed earlier to the path of Samech (60). This path includes the sound of [ks] and its components [s] and [k] in English. The Greek letter Chi, Χχ, has more the sound of Ch [ch] that relates to Cheth. It has a value of 8.

The Y is a vowel modifier with the sound of initial [i]. It has a value of 10.

The Z has the same position as in Greek and Hebrew. Its value is 6.

CHAPTER SEVEN — EPILOGUE

THE manuscript of the *Book of the Law* (*Liber L, Liber XXXI*) is the primary authority for Thelema and the Æon of the Child. Any changes can be readily seen and evaluated. The other Class A books, plus *The Vision and the Voice*, elaborate its message. *The Book of the Law* uses an ancient Egyptian mythology of god forms—Nuit, Hadit, and Horus (Heru-Ra-Ha = Hoor Paar-Kraat and Ra-Hoor-Khuit)—to personify the operation of the universe.

The defining message of *The Book of the Law* is based on the authority of Hoor-Paar-Kraat. He transmitted it through Aiwass to Crowley. Crowley became the prophet of the Æon. It is evidence of his contact with the gods, or a Secret Chief. Crowley believed the scribe Ankh-af-na-Khonsu (of the Stele of Revealing) was his earlier, manifest reincarnation.

The underlying approach to Thelema is dualistic. Without contrast, knowledge cannot be recognized. The original monad reveals itself by producing the dyad. One side of the dyad divides again, making the contrast more evident. In contrast, love is the return of the dyad to the monad, the ecstasy of union.

Thelema emphasizes respect for the individual. Its thrust involves Will (Thelema) and Love (Agape). This is succinctly stated in Chapter One of all versions of *The Book of the Law*:

Do what thou wilt shall be the whole of the Law.	I: p. 10-11, verse 40
Thou hast no right but to do thy will.	
Do that and no other shall say nay.	I: p. 11, verse 42
Love is the law, love under will.	I: p. 17, verse 57

While these statements may seem to give *carte blanche* for individual behavior and belief, it is illusion. A Star can believe what he will, that does not guarantee the veracity of his belief.

First, each individual must determine his Will. This is neither easy nor quick. It is easy to confuse Will with whim.

Second, each individual must apply his Will responsibly. This requires constant evaluation and respect for principles, and applying them to daily life.

Third, each individual must respect the Will of others. To expect freedom and respect, the individual must extend the same toward other Stars.

Each individual determines his own relationship to the Universe and its Mysteries. The motto of *The Equinox*: “The Method of Science, the Aim of Religion,” professes that Science and Religion have the same goal. Only their approach is different.

Symbols, letters, words, numbers and formulas transmit the Mysteries. These symbols are interrelated and have traditional and accepted meanings. With the Æon of the Child, they take on new interpretations. Understanding them enriches the path to Will and achieving initiation. The Class A libers provide guidance. They culminate in a system for organizing knowledge. The system is demonstrated here, using a few key references.

Liber XXVII, Liber Trigrammaton presents two congruent 3-d models of the Universe—the Cube of Space and the Quantum Tree. These models provide bases for decoding the Mysteries of the Æon of the Child. *Trigrammaton* deals with sephiroth in Worlds.

Each sephira has a light and a vessel. A particular Mystery of Trigrammaton involves the central position of Da’ath, Knowledge. It is the only World (sephira) connecting directly to all other worlds. It straddles the Abyss.

Liber XXXI, The Book of the Law, presents the Mystery of the Letters, the paths on the Tree of Life. Secrets are hidden within the text of the original manuscript, but not in the typeset editions. The letters name the paths that connect sephiroth. The Mysteries of the Glyph (Chapter I), the Riddle (Chapter II), and the Line and Circle Squared (Chapter III) are interpreted. They extend into the alphabet, the numbers and Tarot trump.

The Mysteries of Initiation occur in them all.

Liber CCXXXI, the Atus of Tahuti contains a composite set of symbols describing the course of Initiation. It correlates to the 22 Hebrew letters, which function as an index to other correspondences. The Mystery of the Tarot lies in its dual nature, and its final return to unity.

Liber CDXVII, The Vision and The Voice projects a view of the Æon of the Child into the future. The voice of the Angel has authority like *The Book of the Law*. The import of its message will grow as the Æon progresses.

Crowley invoked the 30 Æthyrs in ascending order, culminating with the 1st Æthyr.

The quotation below lists the sequence of the Tarot trump, around which the Tree of Life and Thelemic symbols are organized. The indented names

in the right-hand column are changes of title in Crowley's Thoth Tarot deck of 1944. Those with asterisks traditionally cross the Abyss.

1st Æthyr — LIL

Thou shalt laugh at the folly of the fool.	0. Fool
Thou shalt learn the wisdom of the wise.	I. Magus
And thou shalt be initiate in holy things.	II. High Priestess*
And thou shalt be learned in the things of love.	III. Empress
And thou shalt be mighty in the things of war.	IV. Emperor*
And thou shalt be adept in things occult.	V. Hierophant*
And thou shalt interpret the oracles.	VI. Lovers, Brothers*
And thou shalt drive all these before thee in thy car,	VII. Chariot*
yet by each of these must thou attain to me.	ABYSS
And thou must have the strength of the lion,	VIII. Lust, Strength
And the secrecy of the hermit.	IX. Hermit
And thou must turn the wheel of life.	X. Wheel of Fortune
And thou must hold the balances of truth.	XI. Adjustment, Justice
Thou must pass through the great Waters, a Redeemer.	XII. Hanged Man
Thou must have the tail of the scorpion,	XIII. Death
and the poisoned arrows the Archer,	XIV. Art, Temperance
and the dreadful horns of the Goat.	XV. Devil
And so shalt thou break down the fortress	XVI. Tower
that guardeth the Palace of the King	Tarot King
my son.	Tarot Prince
And thou must work by the light of the Star	XVII. Star
and of the Moon	XVIII. Moon
and of the Sun,	XIX. Sun
and the dreadful light of judgment	XX. Æon,
that is the birth of the Holy Spirit within thee.	Last Judgment
When these shall have destroyed the universe,	XXI. Universe
Then mayest thou enter the palace of the Queen	Tarot Queen
my daughter.	Tarot Princess

Finis

The following text is from a letter sent by Crowley to W. B. Crow on 3 July 1944.

Of course, as you point out, many people, most perhaps, have not yet mastered the Osiran formula, and, of course, it still works and has in fact to be used for nearly everything by most people. But what we need is a genius to work out the dynamics of the formula of Horus. Of this I am, for all practical purposes, totally ignorant. *The Book of the Law* gives manifold instructions, mostly difficult, some seemingly almost impossible, but that is only in the eyes of one born and bred in the Old Aeon.

Some of the rituals in Magick (appendices [of MTP]) may be considered as adumbrations of the new formula. There must be a lot of information in the secret meaning of much in the book. Abrahadabra, 418 and Mahashanah...but we must wait for that genius.

The paragraph shows Crowley's foresight about the evolving Æon, and the importance of *The Book of the Law*. This is a capstone to his legacy and his prophecy.

From *Liber XXXI* Chapter II, 2:

Come! all ye, and earn the secret that
hath not yet been revealed.

And to repeat from the note in the Tunis edition:

Come then, all ye, in the Name of the Lord of
the Aeon, the Crowned and Conquering Child,
Heru-Ra-Ha: I call ye to partake this Sacrament.
Know — Will — Dare — and Be Silent!

Dogma is the tool of tyranny, superstition and suppression.

Study the Manuscript well.
It is the charter of universal freedom.

ABRAHADABRA

AUM. HA.

Love is the law, love under will.
Liber XXXI, I, p. 17

BIBLIOGRAPHY

- ABN//53, "Some Considerations for Studying Liber XXXI: *The Book of the Law*," in: *Unity Uttermost Showed: Proceedings of the VIIth Biennial National O.T.O. Conference*, 2011, in press.
- Achad, Fra. (C. S. Jones), *QBL, or The Bride's Reception*, New York: Samuel Weiser, 1974.
- , *Liber XXXI*, Side Real Productions, 1993 [1919].
- Arndt, William F., & Gingrich, F. Wilbur, *A Greek-English Lexicon of the New Testament and Other Early Christian Literature*, Fourth Revised and Augmented Edition, University of Chicago Press, 1952.
- Berry, George Ricker, *The Classic Greek Dictionary*, Chicago: Follett Publishing Company, 1948.
- Barry, Kieren, *The Greek Qabalah*, York Beach ME: Samuel Weiser, 1999.
- The Holy Bible*, Authorized King James Version, London, New York, Toronto: Oxford University Press, n.d..
- Blavatsky, Helena, *The Secret Doctrine*. Vols. I & II. A facsimile of the original edition of 1888. Los Angeles: The Theosophy Company, 1888 (1982).
- , *Liber LXXI. The Voice of the Silence, The Two Paths, The seven portals*, (with commentary by Frater O.M. Equinox III (1): Supplement pp. 1-132, 1929.
- Breeze, William (Ed.), *Equinox III* (10). New York: Ordo Templi Orientis, Thelema Publications, 1986.

- Caduceus Books, *Untitled Catalogue*. Stoney Stanton, Leicester: Caduceus Books. A sale catalogue of material from the Yorke Collection through Harold Mortlake, n.d. (ca. 1999).
- Churchward, Albert, *Signs and Symbols of Primordial Man*. London: Swan, Sonnenstein, 1910.
- Cirlot, J. E., *A Dictionary of Symbols*, 2nd Edition. New York: Vail-Ballou Press, 1971.
- Coleman, Wade, *Sepher Sapphires: A Treatise on Gematria, The Magical Language*. Fraternity of the Hidden Light, 2008.
- Copernicus, Nicholas, *On the Revolutions of the Heavenly Spheres* [1543](Tr. Charles Glenn Wallis). Pages 505-838 in: *Great Works of the Western World*, Vol. 16. Encyclopedia Britannica, 1952.
- Crowley, Aleister, *The Works of Aleister Crowley*, Volume 2. Foyers: Society for the Propagation of Religious Truth, 1906.
- , *777 vel Prolegomena Symbolica ad Systemam Sceptico-Mysticae Viae Explicandae, Fundamentum Hieroglyphic Sanctissimorum Scientiae Summae*, 1909.
- , *Θελημα*, Volume 3, Privately printed, 1909.
- , *Liber L*. in: "The Temple of Solomon the King," *Equinox I* (7). London, 1912.
- , "A syllabus of the Official Instructions of A.: A.:", in: *Equinox I* (10). London, 1913.
- , "Praemonstrance of A.: A.: and Curriculum of A.: A.:", in: *Equinox III* (1). Detroit: Universal Publishing, 1919. pp. 11-38.
- , *AL (Liber Legis) Sub Figura XXXI*. Tunis: Privately printed, 1926a. The first issue with The Comment.

- Crowley, Aleister, *An Extenuation of the Book of the Law*. Unpublished, 1925b.
- , *The Equinox of the Gods*, Equinox III (1). London, 1936.
- , *The Book of Thoth*, London: O.T.O., 1944.
- Crowley, Aleister (pseudo. Ko Yuen) Shih Yi, *A Critical and Mnemonic Paraphrase of the Yi King*, Oceanside: Monothelema, 1971.
- , (ed. I. Regardie) *Magick Without Tears*, St. Paul MN: Llewellyn Publications, 1973a.
- , *Sepher Sephiroth* (ed. Israel Regardie) In: *The Qabalah of Aleister Crowley*. New York: Samuel Weiser, 1973b. Later editions entitled: *777 and other Qabalistic Writings of Aleister Crowley*.
- , *Magical and Philosophical Commentaries on The Book of the Law*, (John Symonds and Kenneth Grant, eds.). Montreal: 93 Publishing, 1974.
- , *The Commentaries of AL*. First edition. Equinox V (1). New York: Samuel Weiser, 1975. (Copyright Marcelo Ramos Motta)
- , *Magick in Theory and Practice*, New York: Dover Publications, 1976 (1929).
- , *Θελημα, The Holy Books of Thelema*. Equinox III (9). York Beach ME: Samuel Weiser, 1983.
- Liber X vel Porta Lucis
- Liber XXVII vel Trigrammaton.
- Liber XXXI. AL vel Legis. Manuscript facsimile.
- Liber LXVI Stellae Rubeae
- Liber CCXX. AL vel Legis. Typeset edition.
- Liber CCXXXI. Atus of Tahuti.
- , *Comment on Liber Trigrammaton sub figura XXVII*, p. 346-347, in: Crowley, A. et al., *Commentaries on the Holy Books and other papers*, Equinox IV (1). York Beach ME: Samuel Weiser, 1996.

- Crowley, Aleister, *Magick: Liber ABA, Book 4, Parts I-IV*. Aleister Crowley with Mary Desti and Leila Waddell: Edited, annotated, and introduced by Hymenaeus Beta. 2nd rev. ed. York Beach ME: Samuel Weiser, 1997.
- , *The Vision & the Voice with Commentary and other Papers*, Equinox IV(2): 1-251. York Beach ME: Samuel Weiser, 1998.
- Darwin, Charles, *On the Origin of Species by Means of Natural Selection*, London: John Murray, 1859.
- Davidson, Benjamin, *The Analytical Hebrew and Chaldee Lexicon*, Grand Rapids MI: Zondervan Publishing House, 1970.
- Decker, Ronald, & Dummett, Michael, *A History of the Occult Tarot 1870-1970*, London: Duckworth, 2002.
- Diringer, David, *The Alphabet: A Key to the History of Mankind*, 3rd Edition. Vol. 1., London: Hutchinson, 1968.
- d'Olivet, Fabre, *The Hebraic Tongue Restored*, New York: Samuel Weiser, 1976.
- Einstein, Albert, "Zur Elektrodynamik bewegter Körper," *Annalen der Physik* 17: 891-921, 1905. (Tr. John Walker as <On the electrodynamics of Moving Bodies> <http://wwwfourmilab.ch/>)
- Feuerstein, Georg, *Tantra: The Path of Ecstasy*, Boston: Shambhala Publications, 1998.
- Flowers, Stephen E., *Lords of the Left-hand Path*, 2nd ed. Smithville TX: Runa-Raven Press, 1997.
- Gesenius, William (tr. William Robinson), *A Hebrew and English Lexicon of the Old Testament*, Oxford: Clarendon Press, 1951.

- Gikatilla, Abraham, (Rabbi Joseph, the son of), *Sha'are Orah Gates of Light*, San Francisco CA: Harper-Collins Publishers, 1994.
- Glotzer, Leonard R., *Fundamentals of Jewish Mysticism*, Northvale NJ: Jason Aronson, 1992.
- Grant, Kenneth, *The Magical Revival*, New York: Samuel Weiser, 1972.
- Hare, J. B. (tr. E. M. Cox, 1925), *The Poems of Sappho*, 2000 www.sacred-texts.com/cla/Sappho
- Johari, Harish, *Chakras*, Rochester VT: Destiny Books, 1987.
- Kaplan, Aryeh, *The Bahir*, New York: Samuel Weiser, 1979.
- , *Sepher Yetzirah, The Book of Creation*, York Beach ME: Samuel Weiser, 1990.
- Keats, John, “Ode on a Grecian Urn” [1820] in: *The Oxford Book of English Verse: 1250-1900*, (Ed. Arthur Quiller-Couch): Oxford University Press.
- Kircher, Athanasius, *Oedipus Aegyptiacus*, Rome: Vitalis Mascardi, 1652.
- Klein, Ernest, *A Comprehensive Etymological Dictionary of the Hebrew Language for Readers of English*, New York: Macmillan, 1987.
- Knight, Christopher, & Lomas, Robert, *The Second Messiah*, New York: Barnes & Noble, 2000. First published in UK in 1997 by Century Books.
- Kohlenberger, John R., III, *The Interlinear Hebrew-English Old Testament*, Reprint, 1987. Originally published: Grand Rapids. Zondervan (c1979-c1985) with new introduction.
- Kuntz, Darcy, *The Complete Golden Dawn Cipher Manuscript*, Edwards WA: Holmes Publishing Group, 1996.

- Lachower, Fischel, & Tishby, Isaiah, *The Wisdom of the Zohar, Volume 1*, London: Littman Library of Jewish Civilization, 1989.
- Laurence, R. (tr.), *The Book of Enoch the Prophet*, San Diego CA: Wizards Bookshelf, 1983.
- Lévi, Eliphas, *Dogme et rituel de la haute magie*, Paris: Germer Bailliére, 1856.
- , *Histoire de la magie*, Paris: Germer Bailliére, 1860. Translated as *The History of Magic*, London: William Rider & Son, 1913.
- (tr. A. E. Waite), *Transcendental Magic*, London: Rider, 1896.
- Liddell and Scott, *An Intermediate Greek-English Lexicon*, Oxford: Clarendon Press, 1987.
- Mandelbaum, Allen (tr.), *The Metamorphosis of Ovid*, New York: Harcourt Brace & Co., 1993. Books I and II, pp. 33-52. Story of Phaeton.
- Maroney, Tim, *The Book of Dzryan*, Oakland CA: Chaosium Inc, 2000.
- Martinez, Florentio Garcia, *The Dead Sea Scrolls Translated*, Leiden & New York: E. J. Brill, 1994.
- Motta, Marcelo, See: Crowley, Aleister, *The Commentaries of AL*. First Edition. Equinox V (1). New York: Samuel Weiser, 1975
- , Liber CCXXXI – A Personal research with Notes and Commentaries. Pages 283-394 in: *Equinox V* (2), 1979.
- Mythography, “The Greek Poet Sappho,” In: About Mythography. www.loggia.com Website accessed 1997.
- Plato (Hamilton, E., & Huntington Cairns, eds.), *The Collected Dialogues of Plato*, Princeton: University Press, 1989. Bollingen Series LXXI.

- Ponce, Charles, *Kabbalah*, Wheaton IL: Quest Books, Theosophical Publishing House, 1973.
- Ptolemy (Claudius Ptolomaeus), *The Almagest* [2nd Cent c.c.] (tr. R. Catesby Taliaferro), Pages 1-478 in: *Great Works of the Western World*, Vol. 16. Encyclopedia Britannica, Inc. 1952.
- Regardie, Israel, *The Complete Golden Dawn System of Magic*, Phoenix AZ: Falcon Press, 1984.
- , *The Law is for All*, Minneapolis: Llewellyn, 1975.
- Ritsema, Rudolf and Shantena A. Sabbadini, *The Original I Ching Oracle*, London: Watkins Publishing, 2005.
- Russell, C. F., *The Cosmic Dawn* [1930], In: <http://www.cfrussell.homestead.com/files/bw.htm>
- Schlipp, Paul Arthur (ed.), *Albert Einstein: Philosopher-Scientist*, Carbondale IL: Southern Illinois University, 1949. Library of Living Philosophers, Vol. VII.
- Suarez, Carlo, *The Cipher of Genesis*, London: Robinson and Watkins, 1970.
- Symonds, John and Kenneth Grant (eds.), *Aleister Crowley Magical and Philosophical Commentaries on The Book of the Law*, Montreal: 93 Publishing, 1974.
- Te Velde, H., *Seth, God of Confusion*, Leiden: E. J. Brill, 1977.
- Townley, Kevin, *The Cube of Space*, Boulder CO: Archive Press, 1993.
- Wang, Robert, *Qabalistic Tarot*, York Beach ME: Samuel Weiser, 1983.
- Watson, J D. and F. H. C. Crick, "Molecular Structure of Nucleic Acids," *Nature*, Vol. 171, No. 4356: 737- 738. 1953.

- Wescott, W. Wynn (ed.), Preface in: *Eliphas Lévi, The Magical Ritual of the Sanctum Regnum*, 1970.
- Wilhelm, Richard (tr. Cary F. Baynes), *The I Ching or Book of Changes*, Third edition, Bollingen Series XIX. Princeton University Press, 1967.
- Yehuda, Ehud Ben and David Weinstein, *Ben-Yehuda's Pocket English-Hebrew, Hebrew English Dictionary*, New York: Washington Square Press, 1961.

Appendices

- I. Table of Correspondences
- II. Liber XXXI. Chapter III, verse 1
- III. Liber V formulas
- IV. Liber 231 Sigils and Path of Initiation
- V. Ritual Beth-2 for individual use

Appendix I: Table of Correspondences

777 Line	Value Gem.	PATHS TL, QT	VESSEL Trigram.	Seph. Connections TL, QT	WORLD ABDYAS	PHASE QT
11	1	ALEPH	111-112	<i>Keth-Chok</i>	AB	U L
12	2	BETH	111-113	<i>Keth-Binah</i>	AB	U L
13	3	GIMEL	111-211	<i>Keth-Tiph</i>	AB	U L
14	4	DALETH	112-113	<i>Chok-Binah</i>	B	U L
15	5	HEH	112-211	<i>Chok-Tiph</i>	B	U
16	6	VAU	112-121	<i>Chok-Ches</i>	B	U L
17	7	ZAIN	113-211	<i>Geb-Tiph</i>	B	U L
18	8	CHETH	113-131	<i>Binah-Geb</i>	B	U L
25Br	60	SAMECH-Br	211-311	<i>Tiph-Yesod</i>	B	U L
19	9	TETH	223-322	Ches-Geb	Y	U L
20	10	YOD	223-232	Ches-Tiph	Y	U L
21	20	KAPH	223-233	Ches-Netz	Y	U L
22	30	LAMED	322-232	Geb-Tiph	Y	L
23	40	MEM	322-332	Geb-Hod	Y	U L
24	50	NUN	232-233	Tiph-Netz	Y	L
25Y	60	SAMECH-Yet	232-323	Tiph-Yesod	Y	U L
26	70	AYIN	223-322	Ches-Hod	Y	U L
27	80	PEH	233-332	Netz-Hod	Y	U L
	90	GLYPH	322-323	Geb-Yesod	Y	U L
28	90	TZADDI	233-323	Netz-Yesod	Y	U L
29	100	QOPH	233-333	Netz- <i>Malk</i>	YAs	U L
30	200	RESH	332-323	Hod-Yesod	Y	L
31	300	SHIN	332-333	Hod- <i>Malk</i>	YAs	U L
32	400	TAU	323-333	Yesod- <i>Malk</i>	YAs	L

Path Connections to Central Axis

700	(-Briah	211-222	Tiph- <i>Daath</i>	BD	L
500	KAPH Final	121-222	Ches- <i>Daath</i>	BD	U L
600	MEM Final	131-222	Geb- <i>Daath</i>	BD	U L
700)-Briah	311-222	Yesod- <i>Daath</i>	BD	U
700	(-Yetzirah	222-232	<i>Daath</i> -Tiph	DY	L
800	PEH Final	222-233	<i>Daath</i> -Ches	DY	U L
900	TZADDI Final	222-333	<i>Daath</i> -Geb	DY	U L
700)-Yetzirah	222-323	<i>Daath</i> -Yesod	DY	U

Central Axis

L ≈ 30	Axis Briah	111-222	<i>Keth -Daath</i>	A D	n.a.
A ≈ 1	Axis Yetzirah	222-333	<i>Daath-Malk</i>	D As	n.a.

Note: Path connects vessels of sephiroth; Kether has no vessel.

Riddle parentheses are composite path of Nun final.

Tarot Atu	RIDDLE PATHS AL II:76	Element, Planet, Zodiac	Notes
0. Fool	a ≈ Aleph	Air	
I. Magus	b ≈ Beth	Mercury	
II Br. High Pri...	3 ≈ Gimel	Moon	Non-manifest
III. Empress	4 ≈ Daleth	Venus	
IV. Emperor	A ≈ Heh ≈ A(ries)	Aries	Spring Equinox
V. Hierophant	6 ≈ Vau	Taurus	
VI. Lovers	G ≈ Zain ≈ G(emini)	Gemini	
VII. Chariot	8 ≈ Cheth	Cancer	
XIV. Art (in Br)	k ≈ Samech ≈ k of Gr. Xi	Sagittarius	
VIII. Lust	L ≈ Teth ≈ L(eo)	Leo	
IX. Hermit	2 ≈ Yod, spelled in full ≈ 2(0)	Virgo	
X. Wheel	4= Kaph (Symbol of Jupiter)	Jupiter	
XI. Equilibrium	3 ≈ Lamed ≈ 3(0) ≈ Libra	Libra	Fall Equinox
XII. Hanged Man	M ≈ Mem	Water	

XIII.	Death v ≈ Nun ≈ Greek Nu	Scorpio	Life / Death
	Counterpillar		
XIV. Art (in Yetz)	O ≈ Samech cursive ≈ s of Gr.	Sagittarius	
	Xi, or ks =X of Xi		
XV. Devil	O ≈ Ayin Counterpillar	Capricorn	
XVI. Tower	R ≈ Peh ≈ Greek Rho shape	Mars	
(XVIIa. Serpent)	Y ≈ Glyph ≈ § Counterpillar	Ophiuchus	Liber AL I: 57
XVII. Star	X ≈ Tzaddi ≈ English transliteration	Aquarius	
XVIII. Moon	P ≈ Qoph (shape)	Pisces	
XIX. Sun	R ≈ Resh	Sun	Night / Day
XX. Æon	S ≈ Shin	Fire	
XXI. Universe	T ≈ Tau	Saturn	Manifest
Inspiration	(≈ (? Gimel in BriaH =3 = (300)		Top Parenthesis
Information	2 ≈ 2(0) ≈ Kaph ≈5(00) final		
Revelation	4 ≈ 4(0) ≈ Mem ≈ 6(00) final		
Aspiration	(≈ (? 6 =Samech f in BriaH = (600)		Bottom Parenthesis
Conversation	(≈ (?6 Samech f in Ytz (6, 600)		Top Parenthesis
Science	8 ≈ 8(0) ≈ Peh f ≈ 8(00) (Chesed to Hod)		
Religion	9 ≈ 9(0) ≈ Tzaddi f ≈ 9(00) (Tiph to Netzach)		
Questioning) ≈ (Glyph in Ytz (?7 = 9, 900) (Geb to Yesod)		Bottom Parenthesis
EL	A ≈ Blazing Star, radiance from Kether, “Hexagram”		
Adonai	L ≈ Yetzirah, Zeir Anpin, Lesser Countenance, “Pentagram”		

Abrahamadabra is union of Pentagram and Hexagram.

Appendix II — *Liber XXXI* III: 1 and *Liber CCXX* III: 1

The beginning verses of the two chapters of *Liber XXXI*, *The Book of the Law*, are parallel in structure, each having complementary statements separated by an exclamation point.

Chapter I: Had! The manifestation of Nuit.

Chapter II: Nu! The hiding of Hadit.

Each verse identifies the non-manifest viewpoint for its chapter. Had! and Nu! are manifest, Nuit and Hadit are non-manifest. See Crowley (1976), *Magick in Theory and Practice*, page 1, for Crowley's statement about this. The two chapters end as follows:

Chapter I: The Manifestation of Nuit (= Had) is at an end.

Chapter II: The end of the hiding of Hadit (= Nu); and
blessing and worship to the prophet of
the lovely Star.

The last verse of each chapter indicates the end or dissolution of the manifest through union. This reflects the text of Chapter I, page 7:

For I am divided
for love's sake, for the chance of union.
This is the creation of the world that
the pain of division [~~distance~~] is as nothing and
the joy of dissolution all.

Extend a parallel analysis to the Third Chapter.

There should be no dispute about the difference existing between the first word in *Liber XXXI*, the manuscript and that in *Liber CCXX*, the typeset versions, seen above. They are only somewhat similar. A closer transliteration of the first four letters is:

Ahaahadabra! The reward of Ra Hoor Khut

- 1
- 1 *Ahshadabra! The sword of Ra Hoor Khuit.*
 - 2 *There is division hither homeward; there is a word not known. Spelling is defunct; all is not right. Beware! Hold! Raise the spell of Ra-Hoor-Khuit.*

The following verse is relevant to interpretation:

There is a division hither homeward; there is a word not known. Spelling is defunct; all is not right. Beware! Hold! Raise the spell of Ra-Hoor-Khuit.

Crowley (1973) in *Magick without Tears*, letter 50, reminds us about the authority of the manuscript (*Liber XXXI*).

One Textus Receptus, photographically guaranteed. One High Court of Interpretation, each for himself, alone. No Patristic logomachies! No disputed readings! No civil wars and persecutions...

Crowley is clearly saying that the authority of the manuscript of *Liber XXXI* supersedes any subsequent interpretation.

There can be argument about the use or meaning of words (= logomachies), for what the original means is a matter of individual interpretation, each for himself. One suggestion follows.

The second occurrence of the word in verse III: 47 on page 16 (with the grid added) is consistent between *Liber XXXI* and *CCXX*, is clearly Abrahadabra.

The third occurrence, in verse 75 unequivocally refers to the word Abrahadabra. Compare the shape of the letters in the two occurrences. Note how the first R is emphasized in verse 75. The difference occurs in the first four letters of the word—Ahaa versus Abra.

74 There is a splendour in my name hidden
and glorious, as the sun of midnight it is
ever the son

75 The ending of the words is the Word
Abrahadabra.

The Book of the Law is written
and concealed
Aum. Ha.

There is a splendour in my name hidden
and glorious, as the sun of midnight it is
ever the son.

The ending of the words is the Word

Abrahamadabra,
The Book of the Law is Written
and Concealed
Aum. Ha.

How are these two word forms related?

The final T, parallel to the words Nuit and Hadit, implies that Ra-Hoor-Khut is non-manifest, but the “reward” is manifest. Ahaahadabra becomes a manifest expression of the “reward of Ra-Hoor-Khut.” Without the T, this could be Ra-Hoor or Ra-Hoor-Khu.

By Hebrew qabalah the numerical value of Ahaahadabra is 222, in contrast to the 418 for Abrahamadabra. In Greek and English kabalah, they are 122 and 218 respectively.

Half of 418 is 209. The *Sepher Sephiroth in Liber 777*, starts with the following entries for 209:

אבראה Chief Seer or Prophet (hence Abra-Melin)
אגרה Reward, profit, prize

One can add that אברה is transliterated Abrah. When God made a covenant with Abraham, the Heh was added to his name. (Crowley discusses the relationship between the formulas of ALIM and ALHIM in *Magick in Theory and Practice*, Chapter IV.) Genesis 17: 4 and 5 records the occasion of the change (Kohlenberger, 1987).

וארבה	אחתה	במאד	מאד :	ופל	אברם	על-	פניו
and-I-will-increase	you	greatly	greatly	(3)	Abram	on	face-of-him
ודבר	אתו	אלהים	לאמר :	אני	הנה	בריתי	אתך
and-he-said	to-him	God	to-say	I	(4)	covenant-of-me	with-you
לֹאב	המון	ונים :	ולא	יקרא	עוד	את-	***
as-father-of	many-of	nations	(5)	and-not	he-will-be-called	longer	***
שמך	אברם	והנה	שמך	אברהם	כי	אב-	המון
name-of-you	Abram	but-he-will-be	name-of-you	for	Abraham	father-of	many-of
ונים	נתתיך :	והפרתי	אתך	במאד	מאד	גדל	גדל
nations	I-made-you	(6)	and-I-will-make-fruitful	greatly	greatly	you	greatly

D'Olivet (1976) has some interpretative comments about the use of the letter aleph, א on page 287: "As symbolic image it represents universal man, mankind, the ruling being of the earth. In its hieroglyphic acceptation, it characterizes unity, the central point, and the abstract principle of a thing. As a sign, it expresses power, stability, continuity... It takes the place of the emphatic article ה [h] either at the beginning or at the end of words."

The Heh (E, HE) is the symbol of universal life. It represents the breath of man, air, spirit, soul; that which is animating, vivifying. "HA, אה, is every evident, demonstrated and determined existence. It is every demonstrative movement expressed in an abstract sense."

The difference between 209 and 222 is 13, Unity, Achad, אחד. The "reward" of Ra-Hoor-Khut (non-manifest) is as the manifest Chief Seer (of the Æon) as One, or alone. The product of Nuit and Hadit. He is the titular non-manifest Lord of the Æon.

Both Abrahadabra and Ra-Hoor are 418 in Hebrew qabalah, and 218 in Greek and English.

Liber XXXI I: 49:

Hoor in his secret name and splendour is the Lord initiating.

Horus, Hoor, and Ra-Hoor are manifest expressions of Ra-Hoor-Khuit. Had is the manifestation of Nuit.

Liber XXXI III:35:

The half of the word of Heru-ra-ha, called Hoor-pa-kraat and Ra-hoor-Khut.

הרו	Hru	211	הוור	Hoor	217	רא	Ra	201
רא	Ra	201	פא	Pa	81	ואר	Hoor	217
הא	Ha	6	כראאת	Kraat	231			
Total		418			529			418
						כות	K(h)ut	35
						Total		453

The value 418 supports the connection among Heru-Ra-Ha, Ra-Hoor and Abrahadabra.

The number 529 is a prime of no apparent direct significance here. However, it is the square of another prime number, 23. The *Sepher Sephiroth* includes קקק , *parted, removed, separated* and חיה , Chiah, Life. Separation may indicate the double nature of HRH; and life, the essence of HPK.

Ra-Hoor Khut adds Khut = 35 to 418. 35 is אגלא , Agla, a name of God; a notariqon of Ateh Gibor le-Olahm Adonai. 453 is נפש חיה the Animal Soul in its fullness.

Hoor-pa-kraat is the Voice in the Silence, non-manifest, who spoke through his minister, Aiwaz, to Crowley during the transmission of the *Book of the Law*. HPK takes his seat in silence, like the origin, the Ain (אין), the sun behind the son (RHK). HPK is in the North, at midnight (Khephra). RHK is in the east, at dawn.

The obverse of the Stele of revealing shows Ankh-f-n-Khonsu making an offering to Horus. The translation of the hieroglyphic box above the falcon-headed god in Equinox III (9): 241 includes “Ra Hor khut chief gods.” This designation parallels the qabalistic analysis of Ahaahadabra as Chief Seer or Prophet and Unity (or Chief, or First). The text of Liber XXXI I: page 13 (Liber CCXX I: 49) describes his taking his seat in the East at the Equinox of the Gods. So, the “reward of RHK” is as the manifest Chief Seer or Prophet of the Æon. Crowley calls the present æon the Æon of the Child, Heru-Ra-Ha.

Liber XXXI states that not all secrets would be revealed to Crowley. Some are hidden in the “chance shape of the letters, and their position to one another.” We have no idea what Crowley actually heard during the dictation by Aiwass, only what he wrote down. His interpretation of the manuscript is personal and enlightened. However, each Thelemite must interpret the original message and text as an individual to find his personal meaning.

Appendix III The Formulas in Liber V vel Reguli

Liber V vel Reguli, a Class D publication of A.: A.:, is an “incantation proper to invoke the Energies of the Aeon of Horus.” Its performance aligns the Macrocosm and the Microcosm (\approx Heaven and Earth) with the body and mind of the Magician. The First Gesture ends with Abrahadabra. After the First Gesture, the Oath of the Enchantment includes five verbal formulas, the subject of this essay.

Crowley provides discussion and explanations for these formulas in *Magick in Theory and Practice* (1976). What is their distinctive application to the Æon of The Child?

$\Theta\epsilon\lambda\eta\mu\alpha$ and $\Lambda\gamma\alpha\pi\eta$ are Greek words for Will and Love occurring in *The Book of the Law* as “Love is the law, love under will.” They express universal principles of the Æon. Both formulas have a value 93 in Greek gematria. FIAOF and AUMGN are modifications of classical formulas. AUMGN does not add to 93, but 100. LASH TAL is an innovative formula of heterogeneous qabalah from which Crowley gets 93.

Thelema or $\Theta\epsilon\Lambda\eta\mu\alpha$!

The word of the law is $\Theta\epsilon\lambda\eta\mu\alpha$ (*Liber AL I: 39*). It means Will.

On page xxv in *Magick in Theory and Practice* Crowley signs off his introduction, among others, with: “The Beast 666; $9^{\circ} = 2^{\circ}$ A.: A.: who is The Word of the Aeon THELEMA; whose name is called V.V.V.V.V. $8^{\circ} = 3^{\circ}$ A.: A.: in the City of the Pyramids,” etc. This is one place he connects a specific word, or himself, to the Word of the Æon.

Θ	=	9
E	=	5
A	=	30
H	=	8
M	=	40
A	=	1
<hr style="width: 20%; margin: 0 auto;"/>		
	=	93 Total

This is classic Greek kabalah. It requires no further discussion.

IAO or FIAOF!

Greek		Hebrew		English	
F Digamma	6			F	6
I Iota	10	Yod (י)	1	I	10
A Alpha	1	Aleph (א)	70	A	1
O Omicron	70	A'in (ע)		O	70
F Digamma	<u>6</u>			F	<u>6</u>
Total	93		81		93

The value of the formula for the Gnostic God IAO is $10 + 1 + 70 = 81$. To bring it into alignment with the Æon of Horus, Crowley adds an initial and final Greek Digamma (F), $6 + 6 = 12$. The resulting sum is 93. The classic spelling *IAΩ* equals 811, so more of Crowley's distinctive interpretation.

This formula is discussed in *Magick in Theory and Practice*, Chapter V, p. 28ff. He adds initial and final Digammas ($F = 6$). He treats them as silent letters, but includes their numerical value. The result is a value of 93 without a change in pronunciation in the modern sense.

The Hebrew equivalent יעא"ו also has a value of 93. See Chapter V in *MTP*. Crowley attributes the digamma to the Manifest Star. The Great Work is to transform the initial F of Assiah (material illusion) to the final F of Atziluth. He includes a description of the attributes of the IAO formula in different Æons. Crowley uses O equivalent to A'in.

One interpretation of the basic IAO formula has A between the "I" of Hadit and the "O" of Nuit. The "A" is the Child Horus, Ra-Hoor-Khuit as the transform. The path of A'in on the QT becomes that of Horus/Set connecting Chesed to Hod, instead of the Golden Dawn TL interpretation of The Devil connecting Tiphareth to Hod.

AGAPE = ΑΓΑΠΗ

ΑΓΑΠΗ is another key term in Thelema. It has a value of 93 in Greek kabalah.

<i>A</i>	=	1
<i>Γ</i>	=	3
<i>A</i>	=	1
<i>Π</i>	=	80
<i>H</i>	=	8
<hr/>		
Total	=	93

Liber AL I: 35 says: This that thou writest is the three-fold book of Law.

In *Liber AL I: 57* it says: "Love is the law, love under will."

$$ΑΓΑΠΗ = ΑΑ = ΘΕΛΗΜΑ$$

$$93 = (3 \times 31) = 93$$

AUMGN or AYMFN

In *Magick in Theory and Practice*, Chapter 6, section 5, Crowley discusses the formula of *AYMFN* in detail. He begins with the classic Hindu mantram *AUM*. He adds *GN* as the silent letter *G* and the putrefaction significance of *N*.

<i>A</i>	=	1
<i>Υ</i>	=	6
<i>M</i>	=	40
<i>Γ</i>	=	3
<i>N</i>	=	50
<hr/>		
Total	=	100

$$M + \Gamma + N = 40 + 3 + 50 = 93.$$

By including the $A + Y = 1 + 6 = 7$, Crowley gets a value of 100. This total expresses “unity under the form of complete manifestation.” He is interpreting the Greek Y as 6, equivalent to the Hebrew Vau. ם (after Heh). The value of Upsilon (after Tau) in Greek usually is 400. In English kabalah, the U and V follow sequentially, and have a value of 6 as well.

LAShTAL

Crowley’s gematria and explanation of the formula LAShTAL is more creative. It is the only one of the five not explained using Greek kabalah. He published this formula first in *Liber Reguli*. He provides a detailed interpretation and defense of his understanding in *MTP* pp. 334ff. Grant (1972) expands on the significance of Set and the LAShTAL formula.

Crowley’s analysis uses Hebrew gematria and the numbers indicating the sequence of Tarot trump.

$$LA + AL = \aleph + \aleph = 31 + 31 \quad \text{by Hebrew Qabalah}$$

$$Sh + T = \vartheta + \vartheta = 300 + 9 \quad \text{by Hebrew Qabalah}$$

$$Sh + T = XX + XI = 31 \quad \text{by Tarot Atus, Marseilles sequence.}$$

This is heterogeneous. The numbers for the trump used by Crowley follow the Marseilles deck sequence (ca. mid-18th Century). These numbers were established prior to the uncovering of the Teth/Lamed switch. Its occult significance was not recognized or attributed to the Tarot until the mid-19th Century.

As a *Practicus* in the Golden Dawn, Crowley learned that the letter Teth, ם, ם, numerical value 9, applied to the card then called VIII Strength or Fortitude (Kuntz, 1996, p. 117). It is found in *Liber 777* and *Magick in Theory and Practice*. In column XIV, the sequence of the trump names follows the Hebrew alphanumeric system without the blind. Strength is Atu VIII. Adjustment is Atu XI. A further detailed discussion of LAShTAL is found in *Magick in Theory and Practice*. This was a switch from Atu XI, its position in the Marseilles deck. It explained one of the “secrets” of the Golden Dawn. Crowley reverted to “XI” and renamed the Strength card “Lust” in his Thoth Tarot deck.

Both the Æon (Shin = Atu XX) and Lust (Teth = Atu XI. *sic*) in the Thoth Tarot sequence can be interpreted as Babalon riding the Beast. Refer also to the Sigils in *Domarum Mercurii* for Teth and Shin in *Liber 22/Liber 231*. The significance of this formula is ShT = Set = Satan as the mediating force between LA (= Not, Nuit) and AL (= Law, God). ShT can be read as the Fire of Lust, or Fire and Force.

Since it is unique to *Liber Reguli*, what makes it apply to the “Energies of the Aeon of Horus”? Surely just 93, *per se*, does not suffice. Crowley’s “force and fire” (= Teth and Shin) describes the energies.

Shin/Teth occurs in the spelling of Satan. Two occurrences in the Hebrew Bible are in Job 1: 12, as “the Satan,” שָׂטָן and in Psalm 109: 6 as “and adversary,” אֹיֵב. This is Satan separate from God, and Satan standing at the right hand of the wicked, respectively.

The approach to LASH TAL, here, uses Greek or English kabalah instead. Then it is parallel to Crowley’s other explanations.

The LA and AL each still have a numerical value of 31 in both Greek and English kabalah.

The Greek ShT = Set = $\Sigma + \Theta = 200 + 9 = 209$.

Sigma (Σ) relates Tarot Atu XX The Æon. Theta (Θ) and Old English Eth (∂), with their value of 9, agree with the proposals of Levi, and published in the Golden Dawn Cipher Manuscript. This leaves VIII Lust, attributed to Leo, in the heavenly zodiacal sequence. Crowley’s double twist in *The Book of Thoth*, page 11, is unnecessary. The sequence follows the tarot trump order given in the 1st Æthyr of *Liber 418, The Vision and the Voice*. It follows the concept of Fire (Σ , Atu XX. Aeon) and Force (Θ , Atu VIII. Lust).

The number 209 doubled is 418, Abrahadabra. Its Greek value is 218.

	Greek	Hebrew
Ra =	101	201
Hoor =	<u>117</u>	<u>217</u>
Total	218	418
Hru =	111	211

Ra =	101	201
Ha =	<u> 6</u>	<u> 6</u>
Total	218	418

Liber XXXI III: 35 states:

The half of the word of Heru-ra-ha, called
Hoor-pa-kraat and Ra-Hoor-Khut.

and in *Liber XXXI* III: 72:

I am the Lord of the Double Wand of Power
the wand of the force of Coph Nia, but my
left hand is empty, for I have crushed
an Universe + nought remains.

Ra-Hoor-Khuit with complement Hoor-Paar-Kraat equals Heru-Ra-Ha (418). Ra-Hoor-Khuit has taken his seat in the East (*XXXI* I: 49), who in “his secret name and splendour” (Heru-Ra-Ha) is the Lord (of the New Æon) initiating. He is the Lord of the Double Horizon, east and west, with the wand of Double Power.

Could ShT = Shin/Tau be an alternative interpretation?

A further view may broaden the application and understanding. The following is a proposal, not a replacement, for ShT as explained by Crowley.

The Golden Dawn exposed the Teth/Lamed switch to be a blind. Instead of the ShT representing Shin/Teth, could it represent Shin/Tau? The comparison may add dimension to the message of the formula.

Alternate expressions or symbols hide secrets from the profane. They can only be revealed by explanation, and their meaning relevant. The true meaning is therefore protected from corruption. For example, an Aleph (א) can be converted to a Tzaddi (צ) simply by re-arranging the lower left corner. A Cheth (ח) can easily be misread as a Heh (ה) when a reader misses the gap in the upper left (Abracadabra vs. Abrahadaba). This is especially in small size type for those not very familiar with Hebrew. Different letters with

similar sounds can be interchanged, *e.g.*, Samech and Shin, Kaph and Qoph. Silent letters can be added to produce particular totals. The resolution depends not only on “mechanics,” but also on a contribution to a particular understanding of truth. In the case of *Liber V vel Reguli*, it must relate to the “Energies of the Æon of Horus,” the object of the ritual.

During the 20th Century, the perception of man moved into 3-d. Not only does man perceive the universe that way, he views his ritual and life within that universe as a multi-dimensional phenomenon. Man perceives the universe more scientifically. These correlate well to the birth of the Æon of the Child. The motto of the *Equinox* is “The Method of Science, the Aim of Religion.”

About the time of the revealing of *The Book of the Law* to Crowley in 1904, Albert Einstein (1879–1955) put forth his theory of special relativity in 1905. Einstein proposed the concept of a space/time continuum. The effects of this paradigm shift moved the concept of the universe into multi-dimensional reality. On earth, latitude, longitude and altitude are the three spatial dimensions, plus time. In the universe, we now see the equivalents—celestial latitude and longitude (as on a star map) plus distance relative to the point of observation, measured in light-years (time). Separate time does not exist.

Contemporaries of Aleister Crowley (1875–1947), Sigmund Freud (1856–1939) and Carl Jung (1875–1961) expanded the understanding of psychology to the nature of consciousness. All were rooted in the Æon of Osiris, but were influential in shaping understanding in their time.

On the scientific and technological side, the United States took over the failed French attempt to build a Panama Canal. It began construction on 4 May 1904. The first ship went through in 1913, and it was formally opened on 15 August 1914. This is contemporary with the reception of many Class A libers in Thelema. Yellow Fever was controlled. The canal was the most massive engineering project since the Great Pyramid. The canal shortened the trade route between the Atlantic and Pacific Oceans. It expanded the role of the United States in world trade, and changed the world balance of power.

Crowley’s awareness of Einstein’s theories at the time of his publishing *Liber V* in *Magick in Theory and Practice* is implied. There is more evidence in *The Book of Thoth* (1944). Tarot Atu XX is generally known as The Judgment or Last Judgment. It has an apocalyptic connotation, *i.e.*, the end of time and a heavenly renewal. Crowley renamed this card Atu XX, The

Æon in his Thoth deck. In doing so, he expanded an esoteric meaning for the Æon of Horus. The design of the card is much different from the older classical decks.

Atu XX is traditionally attributed to the Hebrew letter Shin, fire and change. This shows in the sigil for Shin in *Liber 231*. The *Domus* sigil is a pyramid (= symbol for fire and initiation) and timeless. The qliphothic sigil is the tomb of Christian Rosenkreutz, with the implication of resurrection, more reflecting an older concept of limited time.

In *Liber 231*, the sigil for Teth in *Domarum Mercurii* shows the Beast 666 “under the shadow of the wings” in two dimensions. It signifies Babalon riding the Beast in union. The sigil for the related Shin shows an initiatory chamber within a pyramid—a parallel of a macrocosm overarching in three dimensions the microcosm, and integrated.

Atu XXI is generally titled “The World.” Crowley renamed it “The Universe.” He retains much of the symbolism of the earlier title, though the idea of limitless space is increased in “The Universe” card.

Atu XXI is traditionally attributed to the Hebrew letter Tau, and Saturn. Each of the two sigils for Tau in *Liber 231* underlies the three columns of sigils above. The *Domus Mercurii* sigil is often interpreted as an expression of IAO. It is singular, possibly implying a unified end. The qliphothic sigil has a turtle (one symbol for origins and totem of Set) with the geomantic symbol *Acquisitio* (obtaining). The middle section is a duplex, cross-wired output. It suggests the uncertainty and repetitive aspects of science. The right hand sections double, one part connected. The duality suggests the contrast between nature and deity, science and religion, open possibilities and fixed answers.

The LA—Shin/Tau—AL is then read as 0 (= Not = Origin = Deity)—Space/Time—AL (All = 1 = Totality = Infinity = God).

The numerical value of Shin is 300. That of Tau is 400. The total is 700.

300

The Hebrew mother letter Shin (ש) represents cosmic Fire. It also implies motion (= time) and energy. It is Ruach Elohim (רוח אלהים), the spirit of the gods; it is Yetzer, foundation or formation (יצר); or the gods, Elohim spelled in full (אלהים למד הי יור במם). The trinity or triangle applies here. It applies to both the Shin/Teth and Shin/Tau considerations.

400

The letter Tau (ⲧ) represents completion or fulfillment, or matter. The Universe is the complement or fulfillment of God. The Tau is union, the full expression of which is expressed by the hermaphrodite of Atu XXI.

Suarez (1973) writes:

Tau is the cosmic resistance to the life-breath which animates it. Without this resistance of Tav, life could not come into existence. This resistance to life is that which enables life to produce its prodigiously varied manifest forms.

The broader, esoteric view does not negate the Shin/Teth interpretation. A Shin/Tau interpretation may complement it with its Time/Space, or an Æonic/Universal understanding.

700

Shin/Tau (ⲧⲱ = 700) are the last two letters of the Hebrew alphabet. They can symbolize end or the beginning. They also mean foundation, depict high and low, good and bad (cf. concept of Horus/Set or ⌘/ⲧ in Egyptian mythology).

The value 700 is $5 \times 140 = 5 \times 2 \times 70$. Five repeats the pentagram nature of the ritual. Seventy is the number of A'in, Atu XV, and the Path of the Devil. This path in the Æon of Horus, as seen in the QT, connects Chesed to Hod. Part of the path had been hidden on the GD Tree of Life. In the New Æon, Horus/Set occupies the path. Its dual nature, $2 \times 70 = 140$, fits.

The esoteric interpretation also expresses a paradigm shift that parallels the understanding of A'in in the Æon of Horus. Note also that the sigil for the qliphothic A'in in *Liber 231 (22)* illustrates the "blind man and emasculate" of the related text in *Liber 671 vel Pyramidos*. Te Velde (1976) interprets Horus/Set as a blind Horus and an emasculate Set combined.

The palindrome pattern of knocks for Abrahadabra becomes 4-3-4. In *Liber 777*, under the number 418 (Abrahadabra) a slightly different arrangement It shows the 4-3-4 and $\square \triangle \square$. It says:

Dividing as 3 and 8 (4 + 4), we get Δ of Horus dominating the Stooping Dragon ארר א.

For ארר, 401, Coleman (2008) writes:

The thunderbolt, or *dorje*, is the lightning-borne weapon of the Hidden Light that streaks downward from the void, reifying as it does so earth or matter. The number 401 is also that of the word ארר that means ‘cursing.’ It is the primal curse of the Fire of the Spirit imprisoned in bodily form, described in the Holy Books as ‘the Wrong of the Beginning,’ the beginning being considered as Kether, through which flash the lightnings of the Ain or Eye of the Void.

Is this parallel to the myth of Horus/Set? Stooping dragon and lightning present an interesting, possibly unconscious, juxtaposition of terms.

The five is the pentagram. Using his Latin system of gematria, Coleman (2008) writes for 140:

Ordo seclorum. (Lt) Order of the ages. World Order. The last 2 words on the reverse of the Great Seal of the United States Their numeral identity with *coelum et terra* hits at a deeper meaning, for the motto: “A new order of the ages” is really “A new Heaven and Earth,” a new conception of the meaning of the words “Heaven” and “Earth.”

Appendix IV

Liber CCXXXI and the Path of Initiation

Domus Mercurii		Carcerorum Qliphoth
Aleph		Voice in Silence, God
Beth	Origins, Universe	Contrast, 2-d
Gimel	World, 3-d	Firmament / Waters
Daleth	Earth / Nature	Fool, Initiate
Heh	Gate, The Way	Temporal Rule
Vau	Microcosm	Spiritual Message
Za'in	Spiritual Messenger	Godly Love
Cheth	Brotherly Love	Astral World
Teth	Supernal World	Lion-Serpent, Baphomet
Yod	Erotic Love, Babalon/Beast	Chaos, Confusion
Kaph	Knowledge, Organization	Stasis, Immobility
Lamed	Dynamics, Evolution	Imbalance
Mem	Equilibrium	Purification, Selection
Nun	Initiator, Purifier	Death
Samech	Reincarnation	Resurrection
A'in	Rebirth, Existence	Good / Evil, Horus / Set
Peh	Lucifer	Tradition
Tzaddi	Destruction, Solvè	Will, Determination
Qoph	Instruction	Illusion
Resh	Promise, Coagula	Dawn
Shin	Day	Development, Pupation
Tau	Initiation	Duality, Reality
	Return, Unity	

Appendix V — Ritual 22
(Adapted for individual use)

TO HAVE ANY KNOWLEDGE

Invocation of RHK

1. Ra-Hoor-Khuit! I invoke Thee!
O Thou who art throned upon the sapphire of the ruby heart.

Thee I invoke!

Thou whose head is as the Hawk's,
and thy nemyss as the night sky blue.
Thou whose disc is the glory of the sun,
wherein the Green Serpent hath lifted up his head.

Thee, thee I invoke.

Thou who bearest in thine Hand the wand of Double Power.
In whose other hand is the sovereign and unattainable
mystery of Nothingness!

Thee, Thee, Thee, I invoke.

Thou whose Skin is flaming indigo,
as if the Thirty Æthers were the softness of thy pell.

Thou whose garments are of green and gold,
who bearest the spotted skin of the fierce leopard.

O thou radiance of earth and air, thou sun of brilliance.

Thee, Thee, Thee, Thee, I invoke!

By thy force in the sign of the Ram of Heaven,
I invoke thee to dominate the worm illusion.

Be thou trodden under foot, O partial, O deceptive moon! False moon!
Be thy rays whelmed in the ocean of darkness.

By the power and in the light of Horus thou canst not shine,
nor shall thy delusive ray cast its glimmer on my mind.
For by this spell I bind Thee!
I bind thee by this charm.
By this Word of Might, I bind thee!

ABRAHADABRA.

Directions

2. *Think tranquil and free, like a fawn that lies down in the forest glades virgin of all fear.*
3. *Figure the Sun in his splendour, saying throughout IV "Appear on the throne of Ra."... to "Abide with me, RHK"]*

Simultaneous Invocation of Thoth

4. *The individual becomes Thoth.*
5. *[The talisman of Horus is on the Altar, behind which is the X of Art.]
Positions: W X Altar, Seer. E.*
6. *Proceed in the 4 quarters to make a secret door into the House of Ra (E), Tum (W), Khephra (N) and Ahathoor (S), thus invoking the Four Elements and balancing them. He / she then invokes Maat to equilibrate.*
7. *Hail unto Thee who are Ra in thy rising, etc., (Thoth at prow, Hoor at the Helm.)*

— East	<i>Ra</i> in thy rising abodes of the night
— West	<i>Tum</i> in thy setting abodes of the day
— North	<i>Khephra</i> in thy secrecy abodes of evening
— South	<i>Ahathoor</i> in thy splendour abodes of morning

Invocation of Maat and Thoth

8. Hail unto Thee, O Ma, Goddess of Truth and Justice!
Try thou this Seer on Thy Scales
that thy feather be not stirred by my Breath!

Aye! But if the invocation be not just to a hair;
if my knowledge be imperfect —

Now I see Thee, O glorious pluméd One;
Now I see Thee make the sign —

and now —

9. [*As Horus the God whom the Seer is worshipping, apply +.*]
(*Abramelin oil to forehead of seer.*)

I invoke the vision of Thoth.

10. [“Open the mind of the Seer to message of Thoth.”]

May my mind be open to his message.

Appearance of the Light

11. *Then appeareth the Light in Darkness, and the adoration is unto Khephra.*

[*The meditation or scrying begins. Record the results. There is no “right answer or message. Focus on the symbol on the altar.”*]

When the scrying session is complete, continue:

Closing

12. O Thou Light in Darkness,
 who sheddest Thy Glory in the Abyss,
 We adore thee in thy midnight temple.
 Thou hast lightened our darkness.
 Thou hast brought forth knowledge.
 Thou hast appeared, though we invoked Thee not.

Hail unto Thee that travellest under Heaven in Thy Bark,
 O Thou who ridest over the heavens of Nuit in thy strength,
 O Khephra, thou Head of the Beetle,
 Thou that controlllest the mysterious rites of midnight.

I adore thee and I invoke Thee.
 I bow down before thee.
 Are there any Gods like unto Thee, Our Lord?

Be graciously pleased to abide here in the darkness of earth,
 making the ways light,
 until we come unto the Everlasting Kingdom of the Light,
 where the shadows have no place,
 and the lamp of the Highest is exalted in His temple,
 and the gloom of the Veil of Isis is dispersed,
 and the beauty of Ahathoor is the delight of his / her servant.

13. ۞ ۞ ۞ ۞ ۞ ۞ ۞ ۞ ۞ *Ye Knock.*

Modified from
Magick Liber ABA, Book 4 (1997): 682-683 &
 Manuscript from Warburg Collection