

The
BIBLE'S

awesome

**NUMBER
CODE!**

123456789 

Bonnie Gaunt

BOSTON PUBLIC LIBRARY
Copley Square
Boston MA 02116

The Bible's *awesome* Number Code!

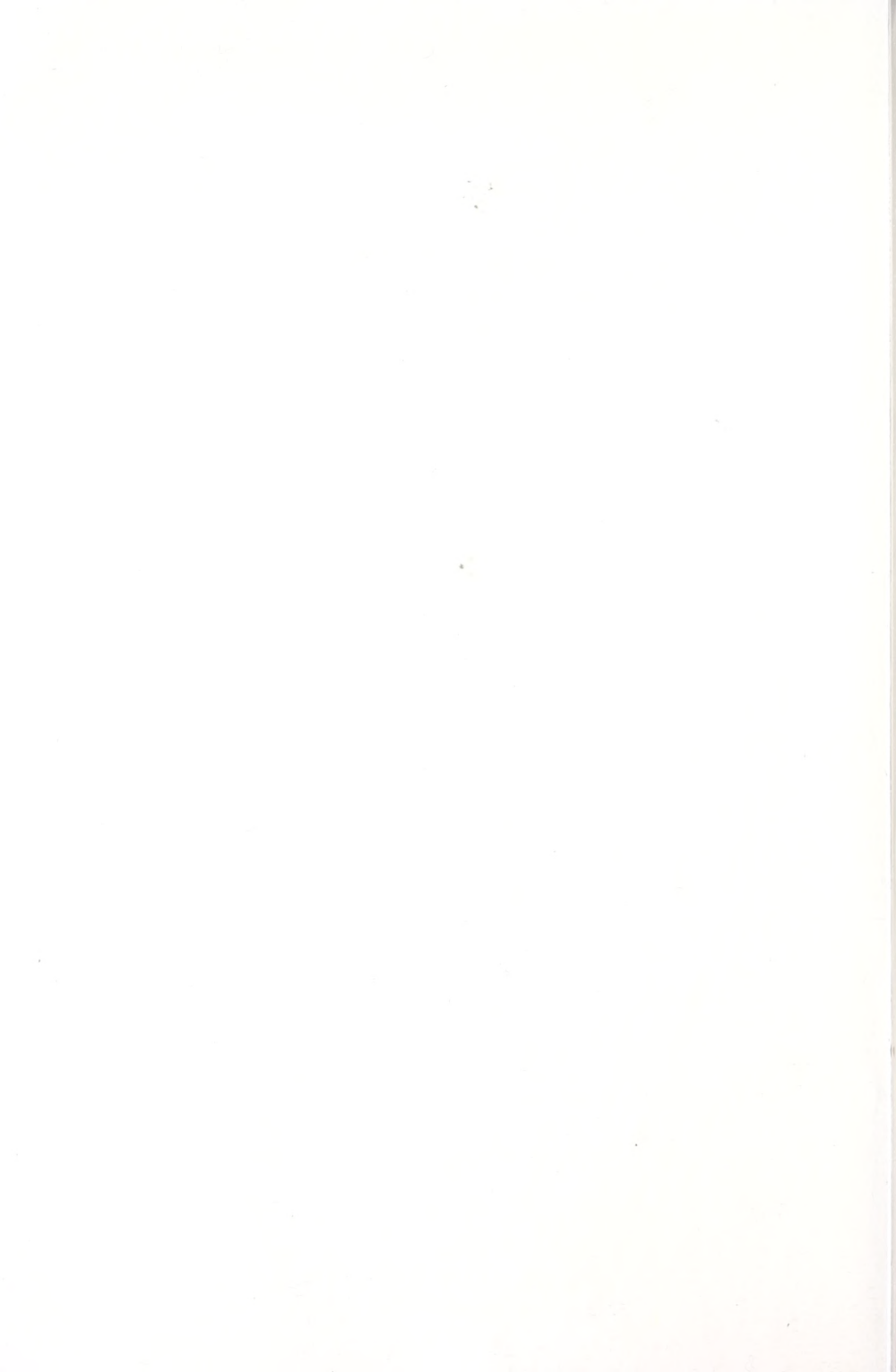

The
BIBLE'S
awesome
NUMBER
CODE!

*Amazing evidence of
divine authorship
of the Bible
and its time schedule
for today's events!*

Bonnie Gaunt

Adventures Unlimited Press
Kempton, Illinois 60946, U.S.A.

Copyright © 2000 Bonnie Gaunt

All rights reserved.

No portion of this book may be reproduced without written consent of the author.

Adventures Unlimited Press
P.O. Box 74
Kempton, IL 60946, U.S.A.

For additional information, write to:
Bonnie Gaunt, 510 Golf Avenue, Jackson, MI 49203, U.S.A.
Telephone 517-784-3605

Manufactured in the United States of America

ISBN 0-932813-83-6



BM525
.G38
2000x

All Old Testament quotations are from The Interlinear Bible, Jay P. Green, Sr., and all New Testament quotations are from the Interlinear Greek-English New Testament, Alfred Marshall D.Litt., unless otherwise stated.

Foreword

Time – that elusive, capricious friend – brings us both joy and disappointment. Trying to understand God’s time is no exception. There were many, including myself, who looked for the “catching away” of the bride with the beginning of the Hebrew year 5760.

There were a few who wrote to me, or called, expressing their disillusionment. However, I received an abundance of loving letters and phone calls from many parts of the world, with messages of encouragement and love, admonishing me to keep on being a faithful watcher. I am deeply grateful for that encouragement, because it assures me that most of the watchers are still faithfully seeking Him and watching for His appearing.

This current study of the Number Code excites me, and it is my sincere desire that it be an encouragement to the readers, for it tells of great and beautiful things that are on the horizon. And that horizon keeps getting nearer.

There are an abundance of books on the bookshelves today which go into rather colorful detail regarding the tribulation and the frightful things coming upon this world. My purpose in writing this book

is to encourage the watchers regarding the time of their waiting and looking for His return, and to look beyond those frightening things, and see the exquisite beauty of what God has promised – the Kingdom of Jesus Christ.

The Number Code (Gematria) abounds with evidence, detailing where we are today on God's time-clock of the ages. The Code tells us of the coming of Jesus as the babe of Bethlehem, and it also tells of His coming again to take His place as King Messiah on the throne of David.

We have now entered the year 2000. The dominion given to Adam in the Garden of Eden has now fulfilled its allotted time, and we stand, today, on the threshold of the great Third Day of which the prophets spoke.

Bonnie Gaunt

February, 2000

Contents

- 1 *Jesus is His Name* 1**
The numeric value of the name of Jesus in both Hebrew and Greek shows a remarkable relationship to planet earth, man's home.
- 2 *What's in a Name?* 9**
The Gematria of the many names of Jesus and their connection to the plan of God for the salvation of man. The amazing relationship of the title "Christ" to the event and date of the Passover. The name of Jesus found encoded in the Old Testament prophecies.
- 3 *From Bethlehem to Golgotha* 33**
The importance of the location and the Gematria of Bethlehem. The time and place of the crucifixion and their geometrical relationships to the Golden Proportion and the size of the earth.
- 4 *Light, Time and the Number Code* 67**
The amazing relationship of the speed of light to Israel's feast calendar and to the crucifixion of Jesus. The Gematria for time and light, and the names of Jesus, the "true light." Man's span of 6,000 years and the Hebrew date 5760. The completion of 2,000 years from the birth of Jesus.
- 5 *The Good Samaritan* 101**
The hidden time prophecy in the parable shown by its Gematria. The suggestion in the parable that Jesus would return after 2,000 years.
- 6 *The Key* 111**
The key of the house of David is in the hands of Jesus Christ – He sits on David's throne. The Gematria for the "Key" and its relationship to the Hebrew year 5760 and the dawn of the great Third Day.

7	<i>Two Signs of the Kingdom</i>	121
	Two miracles of Jesus that have prophetic meaning, showing the time and events of the beginning of the Kingdom of Jesus Christ.	
8	<i>The Unpronounceable Name</i>	131
	The awesome name of Jehovah – its Gematria and its relationship to time, light and the size of the earth. His love in sending His Son, Jesus Christ, to bring salvation is shown by the Gematria.	
9	<i>The Pattern</i>	137
	The discovery of the numeric patterns in the Gematria of the Bible and their relationship to the 3:4:5 triangle, the earth, moon and sun. An exquisite evidence of the magnificent Author of Creation and His time-line for the blessing of man.	
Appendix 1	<i>The Elusive Millennium Date</i>	187
Appendix 2	<i>Gematria – how it works</i>	189
Appendix 3	<i>The Golden Proportion</i>	195
Appendix 4	<i>The Great Pyramid</i>	213

Jesus is His Name

On December 31, 1999, as the world joyously spun into the twenty first century, the strike of midnight moved through twenty four time zones and engulfed the earth in a celebration such as has never before decorated our planet. It was indeed a night to remember!¹

While watching the magnificent display of fireworks light up the sky over Bethlehem, one television commentator exclaimed “Wow! The Bethlehem sky has never seen lights like this before!”

Perhaps not – for all the lights were man-made. However, two thousand years ago there was a marvelous display of heavenly light in the sky over Bethlehem, and it was accompanied by the voice of angels singing.

Interestingly, there has been two thousand years between the two events. The first one heralded the coming of the long-awaited Messiah. The second one was accompanied by the anxious hopes and dreams of millions of Christian people who look for and long for His return as King Messiah.

1 See Appendix 1: The Elusive Millennium Date

The sky over Bethlehem on that memorable night two thousand years ago was filled with joy. As the angels sang, they brought a message to the fearful shepherds. It was a message of hope – an announcement that a child had been born in Bethlehem, and that He would bring peace to the earth.

However, just nine months previously, an angel appeared to a young girl named Mary and made an announcement that changed the world. He said:

“Fear not, Mary; for thou hast found favour with God. And, behold, thou shalt conceive in thy womb, and bring forth a son, and shalt call his name Jesus. He shall be great and shall be called the Son of the Highest: and the Lord God shall give unto him the throne of his father David: And he shall reign over the house of Jacob for ever; and of his kingdom there shall be no end.” (Luke 1:30-33)

Mary was specifically instructed to name the child “Jesus.” It was not an uncommon name in Israel. It was common practice among the Israelites to name their children after great men of old. And the name Jesus is the Greek equivalent of the name Joshua. Mary was probably glad to name her baby after such a great man. But little did she know the beauty of that name – a name that would come down through two thousand years of man’s history – a name that would become the *“Desire of all Nations.”* (Haggai 2:7)

The name Jesus means “Saviour.”

As His name was registered in the Roman census, it was written in Greek, the official language used by the Romans at that time. It was spelled *Ιησους*.

In the Greek language, as used at that time, the letters of their alphabet were also used as numbers. And the letters that spell His name add to 888.

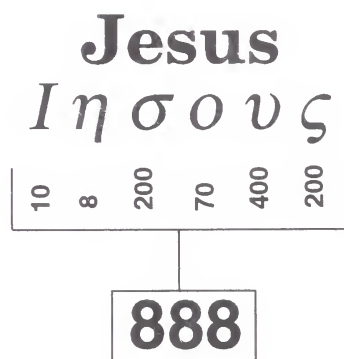

This use of their alphabet was called Gematria. It was also used by the ancient Hebrews in which the 22 letters of their alphabet also had numeric value. The ancient Hebrew name for this method of notation has been lost, and it has become the custom to refer to both as Gematria.

If you are unfamiliar with the use of Gematria it may be helpful to refer to Appendix 2 of this text where you will find an explanation of its methods and its use.

Gematria , as it is used in the Hebrew text of our

Old Testament, and the Greek text of our New Testament, is in fact an awesome code by which we can discern a pattern and a plan that tells the whole story of redemption through Jesus Christ. This ancient Number Code encompasses the entire dimensions of creation and the patterns and cycles of time. It is truly magnificent!

Realizing the magnitude and the beauty of these patterns in the whole of creation, it is no surprise that the name of the One who came to earth to redeem man would bear a number that is planted there.

His name means Saviour. In the Gospel of John we are told that *"The world was made by Him,"* and *"All things were made by Him,"* so we could also call Him a Creator. And in this creation we find the awesome reality, that just as an artist signs his name to his work, so this Creator has signed His name to the worlds that He made.

Because an artist signs his name to his work, we can, centuries later, look at it and know that it is the authentic work of that specific artist. Just so with the created universe, we can look at the signature and know that it is positive evidence of the identity of the One who created it.

This evidence of His identity is nothing that has been contrived by man. It was placed there by the One who made it. Let me share with you its beauty and its magnificence. First, we'll look at His title *"Lord Jesus Christ"* and the work for which he came – the *"salva-*

tion” of man. Then we’ll see how beautifully those names have been planted into the earth.

Lord Jesus Christ

Κυριος Ιησους Χριστος

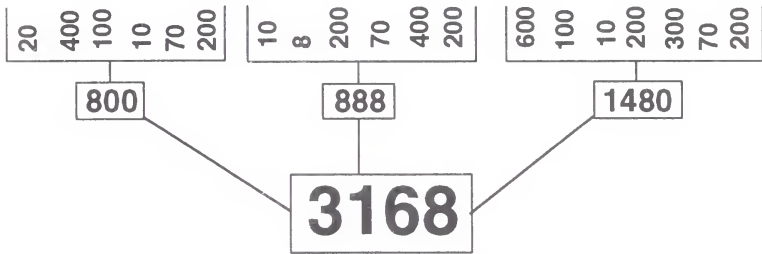

(Hebrew reads from right to left.)

Christ Jesus Lord

אלהא יהושוע משיח

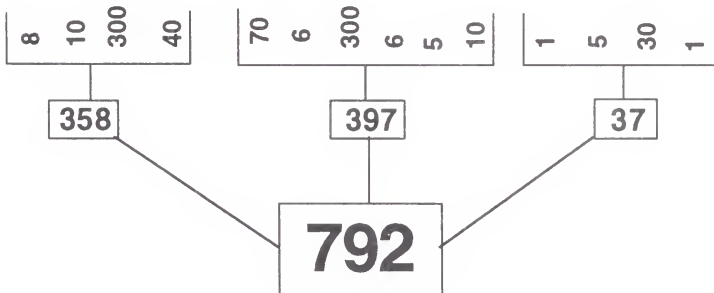

Lord is spelled several ways in Hebrew. The spelling used above is from Daniel 4:2. The name Jesus is Joshua in Hebrew, and it is spelled three different ways. Christ in Hebrew is Messiah.

Salvation

יְשׁוּעָה

400	6	70	6	300	10
-----	---	----	---	-----	----

792

Salvation

הַיְשׁוּעָה

5	70	6	300	10	5
---	----	---	-----	----	---

396

The above numbers, obtained from the Hebrew and Greek texts of the Bible are indeed impressive, for they define the dimensions of our earth.

The Bible tells the story of salvation; and the numbers in the above diagrams tell of the One who will bring salvation, and the place of salvation – the earth. It is not a coincidence! It was planned by the One who made the earth; and He signed His name to this beautiful work. The geometry of our earth, the home He made for man, bears these same numbers.

Perimeter of a square around the earth = 31,680 miles

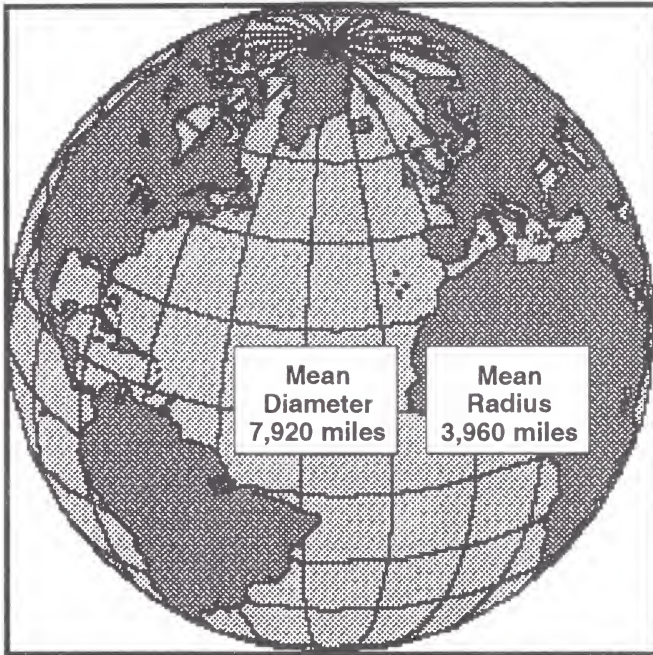

Earth is the place of Salvation through the Lord Jesus Christ.

3168 = Lord Jesus Christ

31,680 miles = Square drawn around the earth

792 = Lord Jesus Christ

792 = Salvation

7,920 miles = Mean diameter of the earth

396 = Salvation

396 = On the earth, על הארץ

3,960 miles = Mean radius of the earth

888 = Jesus

888 = Salvation of our God, ישועת אלהינו

If the writing of this book were to end here, I believe we have observed a truth so incomprehensibly beautiful that we can only stand in awe of the mind of the Creator. However, by the time the last page has been read, we will realize that this book merely scratched the surface of a mine so vast and so deep that it would take several lifetimes to uncover and display all the gems of magnificent beauty that have been planted in His word and in His works.

What's in a Name?

We often sing “Jesus! Jesus! Jesus! – There’s something about that name.” Yes, there *is* something about that name. The angel told Mary to call His name Jesus.

Nearly 800 years previously, the prophet Isaiah had received a message from God which said:

“Behold, a virgin shall be with child and shall bring forth a son; and she shall call His name Immanuel.”

Matthew quoted this text from the book of Isaiah, and surprisingly, we find that its Greek equivalent bears His number of 888. Thus, even though the name prophesied was Immanuel, the prophecy bears the number of the name Jesus. Matthew’s version reads:

“Behold, a virgin shall be with child, and shall bring forth a son, and they shall call His name Emmanuel, which being interpreted is, God with us.”

Matthew was probably not aware that this verse from his gospel has a total numeric value of 8880.

Just a few verses before this, Matthew told of the

visit of an angel to Joseph, the husband of Mary. The angel had told him:

“She shall bring forth a son, and thou shalt call his name Jesus; for he shall save his people from their sins.” (Matthew 1:21)

Joseph knew that the name of Jesus (Joshua) meant Saviour. Throughout the New Testament, the title “Saviour” has a numeric value of 1408. In Gematria, zeros are merely place holders and have no meaning; thus it could also be written as 148. Note on page 5 the title of “Christ” has a numeric value of 1480, which, by the rules of Gematria, could also be written as 148.

Here is a list of some that I have found in my study of Gematria. It is by no means complete, but it does indeed show a pattern of meaning.

1480 = Christ

148 = Son of God, υιος Κυριος

1480 = His Kingdom, βασιλειαν αυτου

148 = Blood, חַיַּוֹת

148 = Passover, פֶּסַח

In I Corinthians 5:7 the Apostle Paul made the statement: *“Christ our Passover is sacrificed for us.”*

The Passover was an event which had its beginnings in the year 1447 B.C. It was the day of the last night in Egypt, before the Israelites began their long,

40-year trek through the wilderness. Terrible and wonderful things happened that night.

God had sent a series of plagues upon Egypt to induce the Pharaoh to release the Israelites from the bondage of slavery and allow them to return to their homeland. That fateful night, the tenth and final plague was about to fall upon that nation — a plague that would take the life of every firstborn, both of humans and animals. And, because the Israelites were dwelling there, the plague would affect their families as well.

God instructed His people to kill a lamb and sprinkle some of its blood upon the doorframes of their homes. When the death angel passed through the land that night, he passed over those homes and spared the firstborn who were “under the blood.” Thus the event came to be known as the Passover.

It is not just folklore that has been handed down from generation to generation. The event really happened. And encoded into this event is the story of redemption through Jesus Christ. The lamb that was killed represents Jesus. It is through the shedding of His blood that those who are “under the blood” are given the hope of life.

The Israelites killed their lamb at 3:00 in the afternoon of the 14th day of Nisan. Exactly 1480 years later (Hebrew inclusive counting), at 3:00 in the afternoon of the 14th day of Nisan, the Lamb of God lifted His head heavenward from that torturous cross,

and proclaimed *"It is finished."* As He breathed His last breath, His head dropped in death.

The use of the number 148 in this pivotal event in history is awesome! It confirms the authenticity of the Number Code as well as the chronology. It is nothing that has been contrived by man. It is there in the Hebrew and Greek texts, and we are but innocent observers of its beauty.

3:00 p.m.
14 Nisan
1447 B.C.

3:00 p.m.
14 Nisan
A.D. 33

1480 Years (Hebrew inclusive counting)

- 1480 = Christ
- 148 = Son of God
- 148 = Blood
- 148 = Passover
- 1480 = His Kingdom

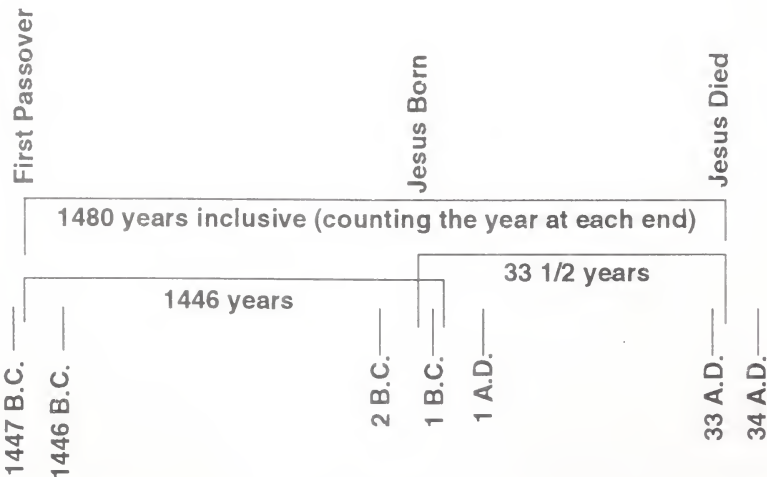

The angel that appeared to Mary had told her to name her baby "Jesus." And the angel that appeared to Joseph instructed him also to name the baby "Jesus." However, when Isaiah prophesied of this birth of a Saviour, he was told that His name would be called "Wonderful." The Gematria for these names is not merely a mathematical curiosity.

888 = Jesus

111 = Wonderful, אֵלֶּפֶּ

There appears to be a pattern. Some of the other names by which He was called reveal an extended use of the number 111.

111 = Wonderful

111 = Son of the Living God, כְּנִי אֵל

1110 = Only Son, υἱος μονοῦς

1110 = The blood of Jesus, τὸ αἷμα Ἰησοῦ

The 1s and the 8s appear often in the Gematria of the Bible, and with meaning. Jesus said "*I am the Alpha and the Omega, the First and the Last.*" He was not just talking about the first and last letters of the Greek alphabet, which are Alpha (1) and Omega (800). He was also referring to the fact that He was the Beginner and the New Beginner. It has been observed in the Number Code that the number 1 represents Beginning. But just as in the musical octave, when

we reach tone number eight, we experience a new beginning of the scale, except at a higher pitch, so likewise in the Number Code we find the octave with its beginning and its new beginning.

We think of the musical scale as ascending because in modern times it is written that way. However, in ancient times the notes were played down the scale, as if descending from heaven. Because of this, the names for the tones were devised to portray this divine origin. The names for these tones were given to us by Guido d' Arezzo about A.D. 1000. We know them in their descending order as DO-SI-LA-SOL-FA-MI-RE-DO. These popular names are really only the first letters of their Latin names – the DO standing for Dominus, which is Latin for Lord. It starts with DO, the beginning, and ends with DO, the new beginning.

John stated it beautifully when he said:

“In the beginning was the Word, and the Word was with God, and the Word was God. The same was in the beginning with God. All things were made by Him; and without Him was not anything made.” (John 1:1-3)

The title “Lord” in the New Testament is the Greek word *Κυριος*, 800, and sometimes it is spelled *Κυριου*, 1000, depending upon its placement in the sentence. Thus it carries the thought of the Beginner and the New Beginner.

When Isaiah prophesied concerning the One who would be called Wonderful, he said:

“For unto us a Child is born, to us a Son is given; and the government shall be on His shoulder; and His name shall be called Wonderful, Counselor, the mighty God, the everlasting Father, the Prince of Peace.” (Isaiah 9:6)

This prophecy contains a piece of evidence of divine authorship that I found to be magnificent. Let me share it with you.

Much has been written today about the Bible Codes. That term usually means the Equidistant Letter Sequence concept or the ELS Code. Upon first hearing of the discovery of this code, I was cautiously curious. I had been studying the Number Code for many years, and had proven it to be authentic and the evidence for the divine hand in the compilation of the scriptures. If this new concept of the ELS Code were true, it would be an added confirmation of the authenticity of the Bible as the Word of God. If the ELS concept could be found also to incorporate the use of Gematria, then it would, in fact, reveal yet a third Code. The idea intrigued me.

But where to start? I did not have computer software that could run that kind of a test, and the idea of doing it manually was inconceivable. Yet my curiosity compelled me to give it a try. With a Masoretic

Text in my lap, I began flipping through its pages, trying to get ideas for a good place to start. Suddenly my eyes fell on Isaiah 9:6. This was probably the most well-known text in the entire Old Testament which was a clear prophecy of the coming of Jesus. Perhaps the Hebrew text would reveal something by an equidistant skipping of its letters.

Not knowing what skip sequence to use, I began with 7. I counted off every seven letters and assigned the numeric value to each seventh letter. When finished with that exercise, I totalled the numbers that I had obtained. When I saw the answer on my calculator I sat there in shock. The total was 888.

Perhaps I had made a mistake. I repeated the test, and again obtained a total of 888. My pulse was racing with excitement. Could it be possible that God had encoded this prophecy by both the ELS Code and the Number Code? Could it be possible that encoded within this text that clearly points to Jesus, is the number of His name? Was my excitement clouding clear thinking? Perhaps it was simply a coincidence, and not the intention of the Author. Yet, I had to know.

With the Masoretic Text open to the book of Isaiah, I began flipping pages again. But I did not go far before my eyes again fell on a well-known text that is a clear prophecy of the coming of Jesus. It was Isaiah 11:1. Quickly I counted off every seventh letter and assigned their numeric values. And with calculator in hand, I added them. As I punched the "equal" key on

the calculator my eyes hurriedly looked at the display. It had three wonderful numbers in it – they were 888.

The book dropped to the floor as I jumped up and began running around the house shouting, “It’s real! It’s real! It’s real!”

Let me share them with you. Remember, Hebrew reads from right to left.

Isaiah 9:6

“For unto us a child is born, unto us a son is given, and the government shall be on His shoulder; and His name shall be called Wonderful, Counselor, the mighty God, the everlasting Father, the Prince of Peace.”

כי ילד ילד לנו בן נתן לנו ותהי
 400 50 30

המשרה על שכמו ויקרא שמו
 6 6 5

פלא יועץ אל גבור אבי עד
 1 90

שר שלום
 300

$$30 + 50 + 400 + 5 + 6 + 6 + 90 + 1 + 300 = 888$$

$$\text{Jesus} = 888$$

Isaiah 11:1

“And a shoot will come up from the stump of Jesse; from his roots a Branch will bear fruit. The spirit of the Lord will rest on him—the spirit of wisdom and of understanding, the spirit of counsel and of power, the spirit of knowledge and of the fear of the Lord—and he will delight in the fear of the Lord.”

ויצא חטר מגזע ישי ונצר משרשיו
200 10 200

יפרה ונחה עליו רוח יהוה רוח
6 10 5

חכמה ובינה רוח עצה וגבורה
3 200 40

רוח דעת ויראת יהוה והריוחו
5 1 8

ביראת יהוה
200

$$200 + 10 + 200 + 5 + 10 + 6 + \\ 40 + 200 + 3 + 8 + 1 + 5 + 200 = 888$$

$$\text{Jesus} = 888$$

In this verse (Isaiah 11:1), which is clearly a prophecy describing Jesus, it calls Him by a rather strange name – a Branch. Isaiah was not the only one who used this name. The prophets Jeremiah and Zechariah also used it, when telling of the One who would come from the line of David and do wonderful things. But it is the Number Code that presents the positive evidence that the One called the Branch is indeed the One who would be called Lord Jesus Christ.

We have observed that the name Lord Jesus Christ has a numeric value of 3168. However, sometimes the final letter in “Lord” changes with the position it holds in the sentence. This is characteristic of the Greek language. Thus Lord sometimes has the value of 800 and sometimes the value of 1000, as shown below.

Lord Jesus Christ

Κυριος Ιησους Χριστος

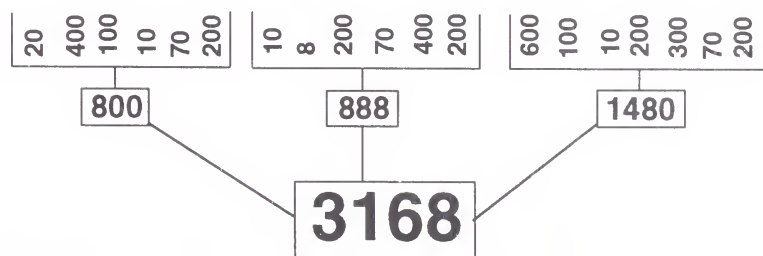

Lord Jesus Christ

Κυριου Ιησους Χριστος

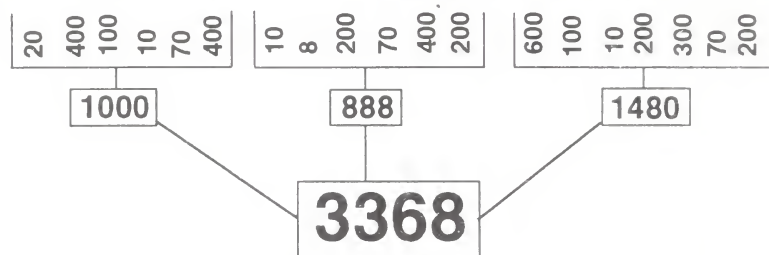

“In that day will the Branch of Jehovah be beautiful and glorious, and the fruit of the earth for pride and for glory for the survivors of Israel.” (Isaiah 4:2)

By adding all the Hebrew letters in this verse, as we find them in the Masoretic Text, we obtain a total of 3368. When further studying the Gematria of this verse, we find remarkable evidence that it was not a random coincidence – it was the purpose and the intent of the One who gave the prophecy to Isaiah.

Hidden within this one verse is the name “Jesus,” as well as several other identifying titles and descriptions of Him. It bears the marks of a Master of encryption. It also attests to the fact of one Author of both Old and New Testaments – the God of heaven! How else can we explain the beauty and harmony of the Gematria that is displayed here!

Reading the words in the exact order as they appear in the Masoretic Text, we find the following.

296 = The Branch of Jehovah, beautiful
296 = and the fruit
+ 296 = of the earth
888

888 = Jesus

Going to the New Testament we find this number, 296, is also descriptive of Jesus.

2960 = Son of Man, *υιος του ανθρωπου*
296 = Only begotten, *μονογενη*

The prophet Zechariah also wrote about the Branch, and it becomes apparent that they were not his words, but the words of the One who gave him the words to write.

“The Man whose name is the Branch, He shall grow up out of His place, and He shall build the temple of Jehovah.” (Zechariah 6:12)

Adding all the Hebrew letters in this verse as they appear in the Masoretic Text, we obtain a total of 2368. What a beautiful confirmation that this One who will build the temple of Jehovah is none other than Jesus Christ, for it is the number of His name.

Jesus Christ

Ιησους Χριστος

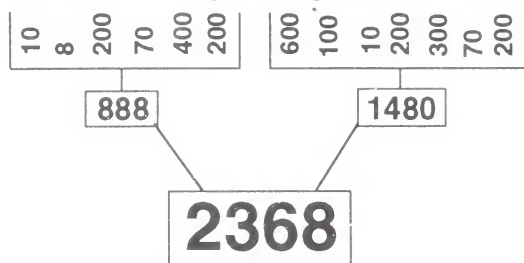

Jesus Christ

Ιησου Χριστου

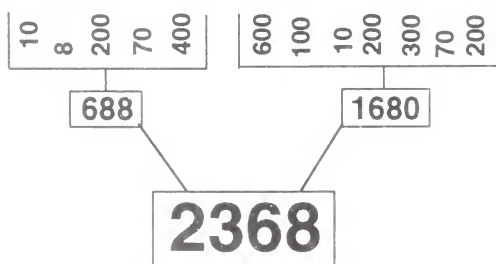

Jesus is the Branch out of the root of David – He is the promised King of David’s dynasty. And His name is masterfully interwoven into the prophecies by both the ELS Code and the Number Code. I stand in awe of this display of divine guidance in the writing of the scriptures. It is truly the work of God, for it is far beyond the scope of man’s ability.

Jesus has another name which is seldom used, except perhaps in Christmas songs. It is Immanuel.

For many years I have wondered why God had instructed Isaiah to write that this child of the virgin would be called Immanuel, but when the time came for Him to be born, Mary and Joseph were each instructed to call Him Jesus.

Isaiah had written:

“Therefore the Lord Himself shall give you a sign, Behold, the virgin shall conceive and shall bring forth a son; and she shall call His name Immanuel.” (Isaiah 7:14)

When Matthew records this, he begins by telling us that the Lord appeared to Joseph in a dream, and said:

“Joseph, thou son of David, fear not to take unto thee Mary thy wife: for that which is conceived in her is of the Holy Spirit. And she shall bring forth a son, and thou shalt call his name Jesus: for he shall save his people from their sins.”

Then he immediately follows this by saying:

“Now all this was done, that it might be fulfilled which was spoken of the Lord by the prophet, saying, ‘Behold, a virgin shall be with child, and shall bring forth a son, and they

shall call his name Emmanuel,' which being interpreted is, God with us."

For many years this has seemed inconsistent to me. Why the double message? Why prophesy that His name would be Immanuel, and then when the time comes for the birth, tell them that His name is to be Jesus?

Let's look at that name – Immanuel.

Immanuel

עִמָּנוּ אֵל

30	1	6	50	40	70
----	---	---	----	----	----

197

God with us

Θεος μεθ ημων

9	5	70	200	40	5	9	8	40	800	50
---	---	----	-----	----	---	---	---	----	-----	----

284

54

898

1236

When I first saw the number 197 it did not mean much to me, for it did not appear to fit into the number patterns that I had found throughout both the Old and New Testaments. Then one day I received a letter from my friend, Neil Pinter who lives in Borger, Texas. He does some marvelous things with God's numbers. He showed me the magnificent reality of the number 197 and how it relates to the name of Immanuel. He did the math, and found that the entire surface area of our planet earth is 197 million square miles. The relationship to Jesus is indeed profound!

This is of course based on earth's mean diameter of 7920 miles, considering earth as a smooth sphere rather than its actual mountainous and polar flattened condition.

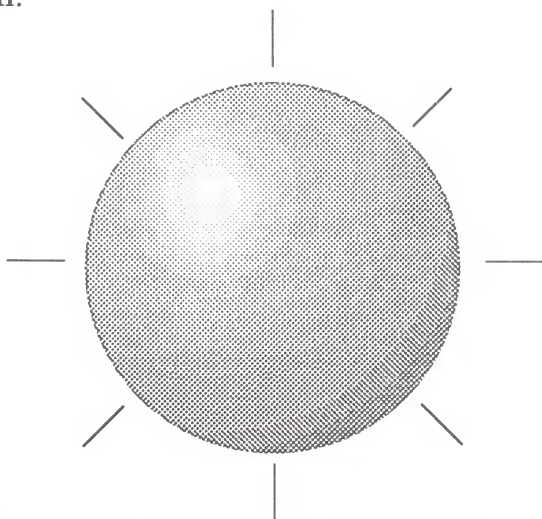

Entire surface area of a smooth sphere of the earth
197 million square miles
197 = Immanuel

We have seen that the diameter of the earth – 7,920 miles – bears the name Lord Jesus Christ. And we have seen that a square drawn around the circumference of the earth – 31,680 miles – also bears the name Lord Jesus Christ. Now we find that the entire surface area of our planet – 197 million square miles – bears His name Immanuel.

Earth's circumference also bears His name. It is, perhaps, a little more subtle, yet beautiful!

The prophet Joel spoke of a time when Israel, and eventually the whole world, will learn righteousness. He recorded it in language describing the life-giving rain that comes at seed time and harvest time. He said:

“Be glad then, sons of Zion, and rejoice in Jehovah your God. For He has given you the former rain according to righteousness, and He will cause the rain to come down for you, the former rain and the latter rain” (Joel 2:23)

In some translations this reads *“He has given you a teacher of righteousness according to righteousness.”* Of course, that Teacher is none other than Jesus Christ. The former rain and the latter rain are personified in Him.

Reading the words in the sequential order in which they appear in the Masoretic Text, it says: *“And made to come down to you the rain.”* Taking each of the Hebrew letters in this statement, and multiply-

ing them together (instead of adding) produces a number that is the rounded figure for the circumference of the earth. (When multiplying the numeric values of the letters it is necessary to drop the zeros because they are cumbersome and unnecessary, and not a part of the Gematria.)

248832 = And made to come down to you the rain

The circumference of the earth, based upon the mean diameter of 7,920 miles is 24,881.392 miles. The difference amounts to approximately 1/2 mile in diameter, and since our figure of 7,920 is also a rounded figure we are well within the area of accuracy for the intended design.

It is awesome indeed to find that man's home, the earth, is literally surrounded by the name of Jesus. He was the agent of Jehovah in the creation of all things. John told us that "*all things were made by Him and without him was nothing made.*"

It is strangely similar to something that the Apostle Paul said when he was in Athens. He had found in Athens many images of the gods of the Greeks. But when he ascended Mars Hill, he found there an altar with the inscription: "To the Unknown God." This commanded his attention and prompted him to give a brief lecture to those who were nearby. He said:

“Ye men of Athens, I perceive that in all things ye are too superstitious. For as I passed by and beheld your devotions, I found an altar with this inscription: TO THE UNKNOWN GOD. Whom therefore ye ignorantly worship, him declare I unto you. God that made the world and all things therein, seeing that he is Lord of heaven and earth, dwelleth not in temples made with hands; neither is worshipped with men’s hands, as though he needed anything, seeing he giveth to all life, and breath, and all things; and hath made of one blood all nations of men for to dwell on all the face of the earth, and hath determined the times before appointed, and the bounds of their habitation; that they should seek the Lord, if haply they might feel after him, and find him, though he be not far from every one of us: For in him we live, and move, and have our being.” (Acts. 17:22-28)

Indeed, in Him we live and move and have our being! For Jesus, as the agent of Jehovah in the creation of all things, has placed His name in the entire geometry of the earth – the home in which we dwell.

In the 8th chapter of Proverbs we are given a description of His work of creation. It is stated in the first person singular, as if He were the one telling us

of all that had happened in the formation of the earth and preparing it for man's habitation. And He ends with a precious and surprising statement.

“Jehovah possessed me in the beginning of His way, before His works from then. I was set up from everlasting; from the beginning, before the earth ever was. When there were no depths, I was spun out (brought forth); when there were no springs heavy with water. Before the mountains were settled; before the hills, I was spun out (brought forth); before He had made the earth and the fields, or the highest part of the dust of the world. When He prepared the heavens, I was there; when He set a circle on the face of the deep; when He set the clouds above; when he made the strong fountains of the deep; when He gave to the sea its limit, that the waters should not transgress His commands when He decreed the foundations of the earth; then I was at His side, like a master workman; and I was His delight daily, rejoicing at every time before Him; rejoicing in the world, His earth; and My delights were with the sons of men.” (Proverbs 8:22-31)

This beautiful text describes Him as the master workman of the Father, daily pleasing and delighting Him. He rejoiced in the creation of the earth and in the preparing of it to be man's home. But when all

was done, His delight was with the sons of men.

At first, it causes us to wonder: in view of His intimate interaction with the Father in all the works of creation, why would His delights be with the sons of men? Surely man, in his present sinful state, could not possibly be worthy of such passion.

Perhaps Jesus, Himself, gave us an insight into this magnificent love that He had for His human creation.

When Jesus was with His disciples, He told them some parables regarding the work of establishing His coming kingdom. Recorded in Matthew 13:44 we find:

“Again, the kingdom of heaven is like unto treasure hid in a field; the which when a man hath found, he hideth, and for joy thereof goeth and selleth all that he hath, and buyeth that field.”

Perhaps He was talking about Himself. Perhaps He was telling us that the field was the vast world that He had created, and that He found in it a beautiful treasure – something so precious to Him that He was willing to give all that He had to purchase it.

Then, in reality, on the afternoon of the 14th of Nisan, in the year A.D. 33, He died by the cruel death of crucifixion. He did not die for any sin that He had committed, for He was perfect and without sin. He died for the sin of Adam. He legally purchased the whole Adamic race by His own precious blood. And

when the Roman soldiers came and thrust a spear through His side, His blood spilled out upon the ground. By this He purchased the earth – man’s home – the earth that He had created and given to man for a possession.

Additionally, He found something else in that “field.” He found a bride! Yes, the treasure was in the field, and He came to purchase the whole field. It was born of a love that is far beyond our comprehension.

That incomprehensible love was shared by the Father also, for it involved the willingness to offer His Son as the sacrifice for the sin of Adam.

“For God so loved the world that he gave his only begotten Son, that whosoever believeth in him should not perish, but have everlasting life.”

Jesus’ mission in coming to earth was two-fold: He came to redeem Adam and the whole race which Adam fathered; and He came to take a bride.

It may seem strange that such a momentous event in the history of the human race should have such an obscure beginning. He was born, without publicity or fanfare, in a small, and probably smelly stable, unknown to the rest of the world.

But the announcement was made, and a few humble men listened, and believed. Why would the most important event in the whole history of man be announced to a small group of shepherds on a lonely

hillside in the middle of the night?

Yet, what other birth had ever before been announced by angels? They literally lit up the sky over Bethlehem. But there is no record that anyone except those few shepherds saw it.

On the night of December 31, 1999, as the hands of the clock pointed heavenward at Bethlehem, the fireworks display was televised around the world. The announcer said: "Wow! The Bethlehem sky has never seen lights like this before!"

They were announcing the birth of a year, the birth of a century, and, by some reckoning, the birth of a millennium. The celebration was indeed appropriate, for it announced the beginning of the third millennium from the year of Jesus' birth. The beginning of the great Third Day of prophetic time.

From Bethlehem to Golgotha

Why Bethlehem?

We might answer: "Because the prophets foretold that He would be born there."

That's true. But it does not really answer the question. The more we investigate, the greater becomes the awareness that Bethlehem is indeed a very special place. First, let's look at its remarkable Gematria.

Bethlehem

Βηθλεεμ

2	8	9	30	5	5	40
---	---	---	----	---	---	----

99

The use of 9s in the Bible is quite remarkable because it is in perfect harmony with the use of 9s in the universe.

The number nine represents completion or wholeness. It is the completion of the digits. We saw that

the number eight represented a repeating cycle, the octave, in which the number eight became a new beginning. The number nine goes beyond that and represents the completion of the whole. The ancient mathematicians called the number nine the “finishing post” because it is the limit to which the generative numbers reach. It not only represents wholeness, but also the ultimate manifestation of a concept or thing.

Nine is indeed a very unique number. Mathematicians say that you can do things with nines that cannot be done with any other number. It is also the basis from which all of the other digits can be obtained. We saw how the number one represents beginning. Now let’s multiply nine ones by nine ones, and observe that it will produce a palindrome of all nine digits, putting the number nine precisely in its center.

$$111111111 \times 111111111 = 12345678987654321$$

Michael S. Schneider, in his marvelous book, *A Beginner’s Guide to Constructing the Universe*, had this to say about nines:

Nine is the final number having a specific identity. It represents the highest attainment to be achieved in any endeavor. Nine is the

unsurpassable limit, the utmost bound, the ultimate extension to which the archetypal principles of number can reach and manifest themselves in the world. The ancient Greeks called nine “the horizon,” as it lies at the edge of the shore before the boundless ocean of numbers that repeat in endless cycles the principles of the first nine digits. Nothing lies beyond the principles of nine, which the Greeks called the Ennead.¹

Why is a baby born nine months after conception? It is because its gestation time is complete. Why do we say that a cat has nine lives? It is because of its seeming indestructability. Why do we speak of “the whole nine yards?” It is because we are talking about the wholeness or completion of an action. Why are there nine planets orbiting the sun in our Solar System? It is because it completes the whole.

Prayer is completed by the word “Amen.” It means “So be it.”

Amen

Αμην

1 40 8 50

99

1 Michael S. Schneider, *A Beginner's Guide to Constructing the Universe*, Harper-Collins, New York, NY, 1994, p 302.

The uses of the number 9 in the Gematria of the Bible reveal its meaning. It always has to do with the concept of wholeness or perfection. And when there is a repetition of nines, such as 99, or 999, the concept is emphasized.

The word *perfection* in Hebrew is כִּלְיִל, and it adds to 90. The first words of the Bible are “*In the beginning God,*” and its numeric value is 999. It is telling us, in code, that God was in the realm of perfection and completion even before He began the work of creation. And the home that He made for the first man was also in perfection and completion, for “*The garden of the Lord,*” (Eden) has a numeric value of 99.

Jesus said “*I am the root and offspring of David.*” As the “*Root*” he represented wholeness and completion. “*I am the Root*” has a numeric value of 999.

It is most interesting to realize that the number of those who stand with the Lamb on Mount Zion in Revelation 7 are said to be 144,000. However, the Greeks did not have the concept of zero. They used the system of Gematria. Thus the number had to be written ρμδ, which is the Gematria for 144, then followed it by the word “*thousands.*” Thus, in Revelation 7 it appears as ρμδ χειλᾶδες, which has the numeric value of 999.

In the light of the above uses of the number nine, it is not surprising that Bethlehem should bear this number. But Bethlehem has another number. The principle and use of Gematria in the Bible not only

has the function of addition, it also has the function of multiplication. When we multiply the number values of each of the Greek letters in the name Bethlehem, we obtain a number that is equally all-encompassing and expresses wholeness.

Bethlehem

Β η θ λ ε ε μ

2 x 8 x 9 x 30 x 5 x 5 x 40

432

(dropping the zeros)

It was in this little town of Bethlehem that the Saviour of the world was born, after a period of nine months gestation in the womb of Mary. The name Mary means "bitter." It signifies the bitterness that the human race had fallen into because of the sin of Adam. Jesus was born of this bitterness because Mary was of the Adamic race. He came to be a Saviour.

Saviour

מ ר ש י ע ו

6 70 10 300 6 40

432

The price that He paid for the sin of Adam effected the release of all who had died in Adam. It was all-encompassing in its scope. The Apostle Paul said: "As in Adam all die, so in Christ shall all be made alive." It included the whole habitable world.

The entire habitable world

World

תבל

30	2	400
----	---	-----

432

All things

παντα

80	+	50	300	+
----	---	----	-----	---

432

All Nations

כל-גוים

40	x	10	x	6	x	3	x	30	x	20
----	---	----	---	---	---	---	---	----	---	----

432

(dropping the zeros)

While studying the Gematria of the Bible, it was exciting to find that Jesus' role as The Branch also bears this special number – 432. This all-encompassing number beautifully describes the One who grows up out of the root of Jesse to become the promised King who will sit on David's throne forever. Isaiah said:

“There is no end to the increase of His government of peace; on the throne of David and on His kingdom, to order and to sustain it with justice and with righteousness from now on, even forever.” (Isaiah 9:7)

The Branch of Jehovah

צ מ ח י ה ר ה

5	x	6	x	5	x	10	x	8	x	40	x	90
---	---	---	---	---	---	----	---	---	---	----	---	----

432

(dropping the zeros)

The prophets indicated that Jerusalem will be the seat of that government and the blessings of peace and righteous rule will flow from there throughout all the world.

Jeremiah was one of the prophets who foretold

these beautiful things. He stated it very succinctly:

“At that time they shall call Jerusalem the throne of Jehovah. And all nations shall be gathered to it, to the name of Jehovah, to Jerusalem.” (Jeremiah 3:17)

Jerusalem

י ר ו ש ל ם

40 x 30 x 300 x 6 x 200 x 10

432

(dropping the zeros)

The study of the number 432 would not be complete without acknowledging the remarkable fact that the radius of our sun is 432,000 miles. It is another confirmation that the work of creation and the Word of God were both part of a master plan.

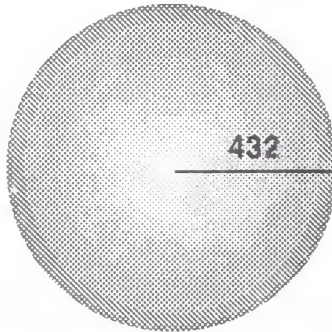

Radius of the sun = 432,000 miles

Micah was the prophet who told us that Jesus would be born in the town of Bethlehem. He called it Bethlehem Ephratah, which means *the beautiful house of bread*. He probably did not know that the One whom he prophesied would be born there would also be called the Bread of Life. And I doubt that he knew he was revealing the name of the One who would be born there. Yet His name is hidden within its Number Code.

Here is what Micah said:

“And you, Bethlehem Ephratah, you who are little among the thousands of Judah, out of you He shall come forth to Me to be ruler in Israel, and His goings forth have been from of old, from the days of eternity.” (Micah 5:2)

Translating the words exactly as they appear sequentially in the Masoretic Text, this verse would begin by saying, *“And you, Bethlehem Ephratah, least.”* Its Hebrew letters add to 1958. It was a number that was seemingly without significance – or so I thought. However, when this prophecy was quoted by Matthew, written in New Testament Greek, its letters still added to 1958. But why? This needed further investigation.

1958 = And you, Bethlehem Ephratah, least

ואתה בית-לחם אפרתה צעיר

1958 = You, Bethlehem in Judea

συ εν βηθλεεμ της Ιουδαιας

Just out of curiosity, I divided 1958 by the Golden Proportion (.618) and to my surprise, the answer that came up on my calculator was 3168, the number for Lord Jesus Christ. Wow! Then in my excitement, I multiplied 1958 by the Golden Proportion and hurriedly looked at the answer on the calculator – it was 1210, the Gematria for “*She shall bring forth a Son,*” from Matthew 5:1. As I pondered all this, I knew that these numbers were not simply random coincidences – they had been designed by a Master Hand, the Hand that formed the world and made man upon it.

Buy why the Golden Proportion? Because it is the divine growth principle that is an integral part of the process of creation. It can be seen in the pattern of the seeds in the sunflower, and in all daisies, it can be seen in the seed pattern of pine cones, in the embryos of all vertebrates, in the swirl of hair on the human head, and in the great galaxies of the starry heavens. That it should be used in the Number Code of the Bible is not surprising, for it is the growth principle upon which all creation is based.

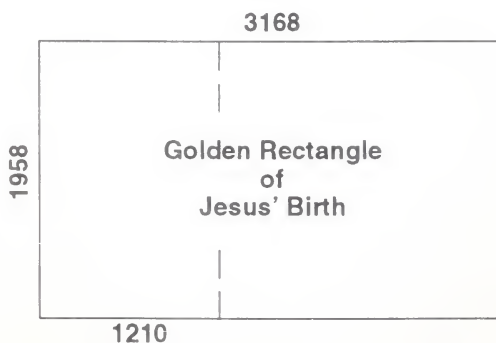

When the angel Gabriel appeared to Mary and told her that she would have a son who would be the Saviour, he also told Mary that her cousin Elizabeth was with child and would soon have a son. Upon hearing this, Mary went to visit Elizabeth.

When the two women met, Elizabeth greeted Mary with, "*Blessed art thou among women, and blessed is the fruit of thy womb.*" (Luke 1:42) The record plainly states that Elizabeth was led of the Holy Spirit to say these words – probably because of their numeric value. The Gematria for "*the fruit of thy womb*" is 1320. It is a number that has deep significance as we shall see shortly.

Mary was a descendant of King David, therefore her child would be considered as being "*from the root of Jesse,*" who was the father of David. Isaiah had prophesied concerning this one who would be of the "*root of Jesse.*" He said: "*And it shall be in that day that the root of Jesse shall stand as a banner for the people.*" (Isaiah 11:10) It has a numeric value of 2136.

These two numbers, 1320 and 2136, define a Golden Proportion. ($2136 \div .618 = 1320$) They both clearly identify Jesus. However, when this Golden Proportion is drawn as a Golden Rectangle, the other parameters created also identify Him.

The hope of every woman in ancient Israel was that she might give birth to the Messiah. It was called "*The desire of women.*" This hope expanded into the concept of "*The Desire of Nations,*" which was a term

used as a name for their Messiah.

The prophet Haggai wrote concerning this One for whom they eagerly awaited. He wrote:

“Yet once, it is a little while, and I will shake the heavens and the earth and the sea and the dry land. And I will shake all the nations, and the desire of all nations shall come. And I will fill this house with glory.” (Haggai 1:6, 7)

The phrase *“The desire of all nations shall come”* has a numeric value of 528. It becomes another piece of the Golden Rectangle. Let’s draw it, and discover its fourth parameter.

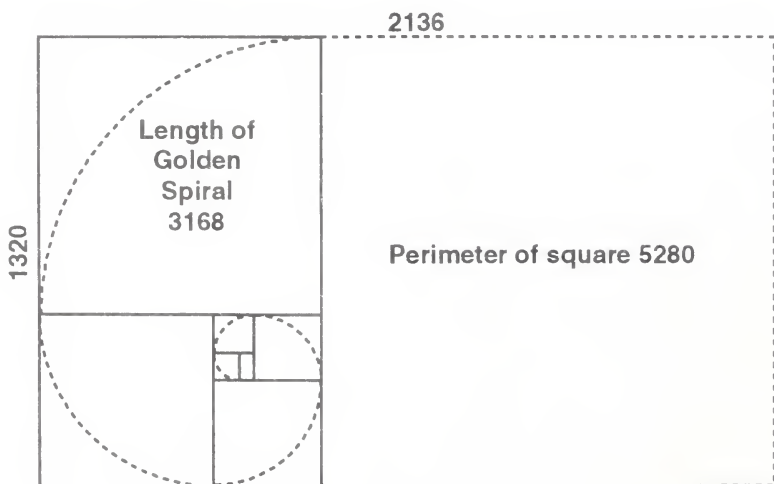

The Golden Spiral that can be traced on the corners of the Golden Rectangle will have a length of 3168, which is the Gematria for Lord Jesus Christ.

The “*desire of women*” was fulfilled in Mary that night, as she gave birth to the Saviour of the world in that tiny stable. Even the angels of heaven rejoiced and sang for joy at His birth. They lighted the sky over Bethlehem that night far more magnificently than the fireworks of December 31, 1999. However, the fireworks were televised around the world. Little did the world know that they were celebrating the very spot on earth that bears the number of His name. Yes, Bethlehem sits at 31.68° from the equator. Jesus was born on the number that He planted in all of His works of creation. The place of His birth was not only spoken of by the prophets of old, it was obviously planned from the creation of the world. No wonder Bethlehem Ephratah bears the number 3168.

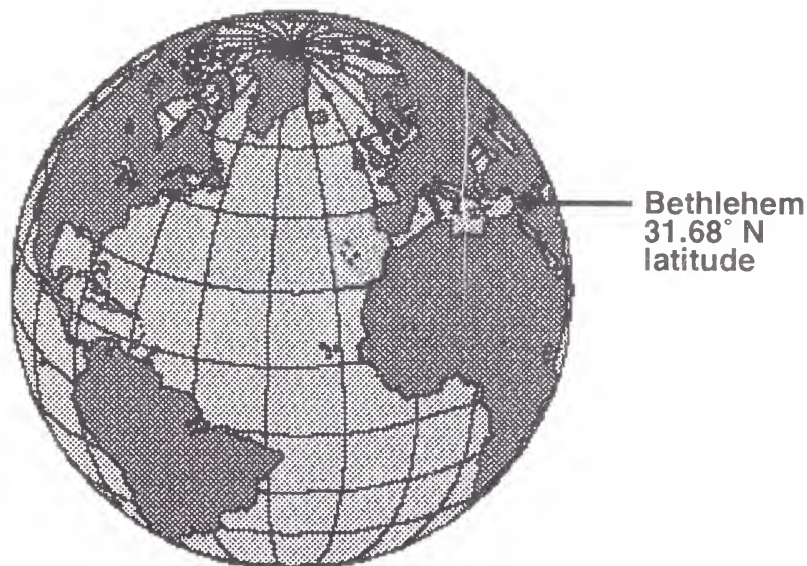

Mathematicians have marvelled at the Golden Proportion for thousands of years. It is inherent in all creation. It is the basis for all physical beauty. We seem to respond instinctively to it, as if it were a bond between man and his environment – a binding covenant of love between the Creator and His creation.

When the only-begotten Son of God came to earth, to become a baby, born in the little town of Bethlehem, it was a binding of heaven and earth by the Golden Proportion. Bethlehem, being positioned on our globe at the latitude of 31.68° from the equator, forms a Golden Rectangle with the polar and equatorial diameters of the earth. It is a magnificent display of divine design – worthy of all the fireworks at the turn of the millennium.

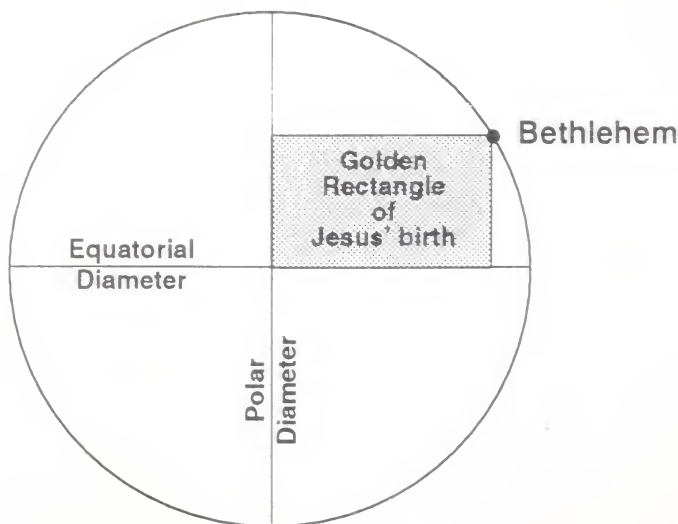

Plato marvelled at the beauty of the Golden Proportion. He called it “the most binding of all mathematical relations, and the key to the physics of the cosmos.” But he was not aware that the One who formed the cosmos had planted His own name there by this most beautiful of all mathematical principles. This Golden Proportion that can be drawn on the relationship of Bethlehem to the polar and equatorial diameters of the earth, has a long side of 3,368 miles. It bears the name of its Maker, the Lord Jesus Christ.

“All things were made by Him, and without Him was nothing made.” (John 1:2)

3368 = Lord Jesus Christ, Κυριου Ιησους Χριστος

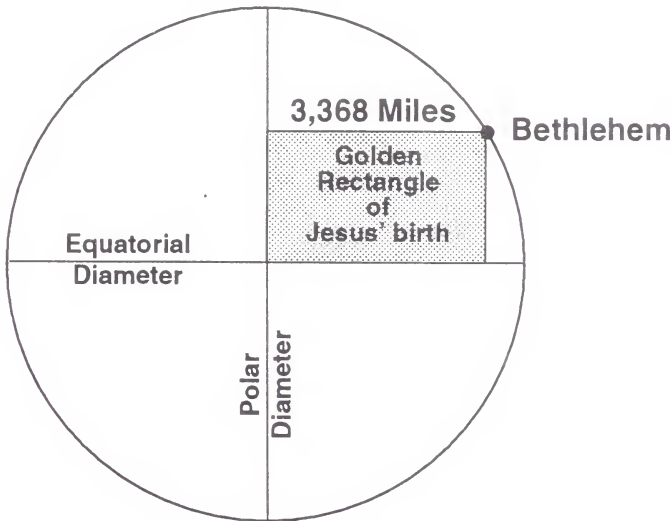

The polar and equatorial diameters of the earth also bear the name Lord Jesus Christ by the use of the Pythagorean Triangle. It is the great 3:4:5 triangle which has come down to us from Pythagoras. It is said to be the single most important theorem in the whole of mathematics, for it establishes a fundamental characterization of time and space and the laws that bind the universe. It is written as $a^2 + b^2 = c^2$, and every school girl or boy learns it at the beginning of geometry class. How I wish that every geometry teacher could also impart to those students the magnificent fact that this simple 3:4:5 triangle is, in fact, the name Lord Jesus Christ, planted in the dimensions of earth.

3168 = Lord Jesus Christ, *Κυριος Ιησους Χριστος*

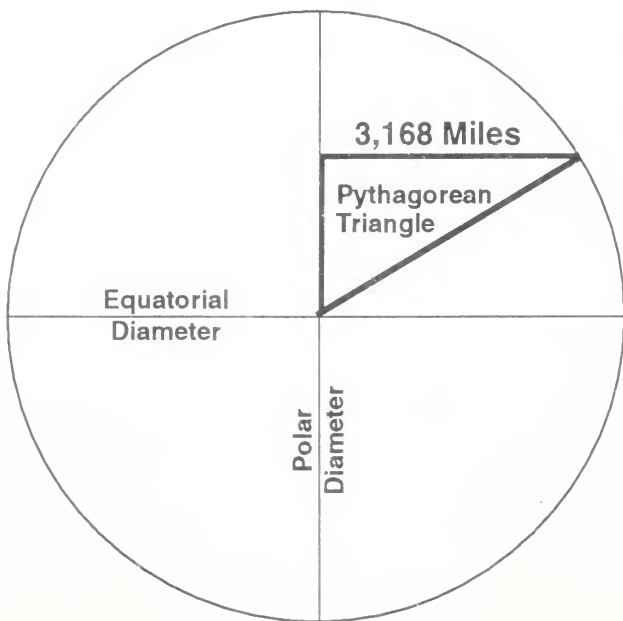

When the number 1236 is multiplied by the Golden Proportion, it produces 764. They are not random numbers. Nor is it by coincidence that they describe the One who would grow up as a Shoot from the stump of Jesse that had seemingly been in “dry ground,” since the dynasty of David had been overthrown in the year 586 B.C.

764 = A Shoot proceeds from the stump of Jesse
(Isaiah 11:1)

1236 = A Root out of dry ground (Isaiah 53:2)

$1236 \times .618 = 764$
$1236 \div .618 = 2000$
God with us = 1236

We have seen that the number 1 represents a Beginning and the number 8 represents a New Beginning. Jesus has provided that new beginning for mankind by paying the price for the sin of Adam. The triplet of 8s raises the concept of 8 to its ultimate manifestation, thus the name Jesus bears the number 888.

When Gabriel appeared to Mary, he gave a very special message – not only in its prophetic content, but also in its number value. The exact words that he

used beautifully convey the concept of 8 and of 888. It is evidence that he was indeed sent from God and that his message was true.

8 x 888 = The power of the Most High shall overshadow thee: therefore also that holy thing which shall be born of thee shall be called the Son of God. (Luke 1:35)

The Apostle Paul conveyed the same message, and, even though he probably was not aware of it, the number value of his statement is identical to that of Gabriel.

8 x 888 = When the fulness of the time was come, God sent forth his Son, made of a woman. (Galatians 4:4)

The number of days from the conception of Jesus in the womb of Mary to the afternoon when He hung upon the cross and said "*It is finished,*" is exactly 12,520 days. All things are done according to God's *Moed* – His appointed time.

Jesus was the fulfillment of the Lamb that was slain for the Passover 1,480 years previously. His death at 3:00 in the afternoon was the same hour that Moses was told to kill the Passover lamb. And, as Jesus hung on the cross, the priests were undoubtedly killing their lambs for Passover.

It was not surprising to find that “*the Passover*,” in Luke 22:11 has the numeric value of 1252.

By now we have ruled out the idea of the numbers being a coincidence. They are God’s numbers, and there are no coincidences with Him. After 12,520 days away from the heavenly courts, in a human body, feeling all the pain and suffering of which human bodies are capable, He offered up His life as the sacrificial Lamb precisely at the time of “*The Passover*.”

12,520 days from Jesus’ conception to His death.

1252 = The Passover

As He hung upon that cross on that most important day in all of history, He was not only the real Passover Lamb, He was also the last Adam, paying the price for the sin of the first Adam. He was the “*Logos*,” the Word of God, who had been with the Father from the beginning. It was through Him that all the work of creation had been accomplished. When God had said “*Let us make man in our image*” He was there as the One who performed that task. Now He had given His very life for that human creation. It was an act of love greater than the world has ever known.

The prophecy that pointed to Jesus in Isaiah 9:6 had said nothing about His being the last Adam, or about His being the great “*Logos*,” the Word of God who made all things. However, encoded into its

numeric values the concept becomes apparent. God had instructed Isaiah to write:

“For unto us a Child is born, unto us a Son is given; and the government shall be on His shoulder; and His name shall be called Wonderful, Counselor, the mighty God, the everlasting Father, the Prince of Peace. There is no end to the increase of His government of peace, on the throne of David and on His kingdom, to order and to sustain it with justice and with righteousness from now on, even forever.” (Isaiah 9:6-7)

If we add together all of the titles by which Isaiah calls Him, their total numeric value would be 1492. It is the same number that becomes apparent in the statement that Paul made regarding Jesus being the “last Adam.” The two descriptions of Jesus were written about 800 years apart, yet they bear the same number – a number that also identifies Him as the *Logos*, the Word of God.

1492 = Wonderful, Counselor, the Mighty God,
Everlasting Father, Prince of Peace

1492 = The last Adam ο εσχατος Αδαμ (I Cor. 15:45)

373 = Word (Logos), Λογος

If we were to draw a square with sides of 373, it would have a perimeter of 1492. The two identifying

numbers are thus drawn together by the unity of the square.

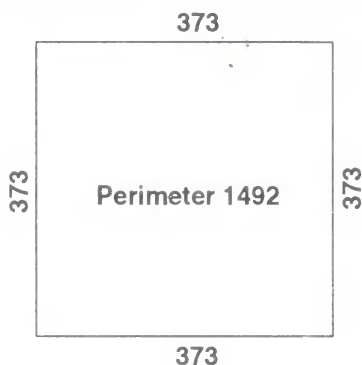

Isaiah wrote about the events of that awful day, and although it was nearly 800 years before the fact, yet he described it as if he had been an eye-witness. He said:

“He was oppressed, and He was afflicted, but He did not open His mouth. He was led as a lamb to the slaughter; and as a ewe before her shearers is dumb, so He opens not His mouth.”
(Isaiah 53:7)

If we were to take the words as they appear sequentially in the Masoretic Text, and add their numeric values we would get the positive identification of the One who was being spoken of.

888 = As a lamb to the slaughter he was led and as a
ewe before her shearers

888 = Jesus

It was on a lonely hill outside the walls of Jerusalem that this Heavenly One, who came to earth to be born, to suffer, and to die as a man, hung on a cruel cross that afternoon. The hill was called Calvary. Its Greek name was *Kranion*, *Κρανιον*, whose numeric value is 301.

At 3:01 in the afternoon, as he looked heavenward and said "*It is finished*," the moon began to eclipse. It was at 3:01 Greenwich Time that the eclipse began. God makes no mistakes with His timing, nor does He rely on coincidences. The word "moon" in the New Testament is *σεληνη*, and its Gematria is 301. Yes, He who had formed the moon and put it into its orbit around the earth, now had given up His human life at 3:01, on a hill called Calvary (301) precisely when the moon (301) began to eclipse. It was the exact hour when the priests were killing the lambs for Passover. Lambs, *אמריך*, has a numeric value of 301.

Calvary was a very special place. It was part of a hill that had become known as the meeting place between God and man. It was once known as Mount Moriah. That was before excavation and construction was done, which divided the hill. It was the rocky summit of Mount Moriah where Abraham offered his son, Isaac, in sacrifice – a picture of God offering His only begotten Son, Jesus, on this same hill nearly 2000 years later.

During the intervening years, this hill became

the property of King David. He purchased it from a man named Ornan, ארנן, whose numeric value is 301.

Later, David's son, Solomon, built the beautiful temple there. It was indeed the meeting place between God and man. The place on which the temple was built came to be known as The Rock, הצור, whose numeric value is 301.

After the temple was destroyed by Nebuchadnezzar in 586 B.C., The Rock lay desolate until the return of the three tribes, Judah, Benjamin and part of Levi, from their Babylonian exile. Under the leadership of Zerubbabel, another temple was built upon it.

In 21 B.C., Herod the Great, who ruled the land of Judea under Caesar Augustus of Rome, rebuilt the temple. This beautiful and imposing edifice was destroyed by the army of Titus in A.D. 70 – Rome's seige of Jerusalem. The only thing that remained was a portion of the retaining wall, now known as the Wailing Wall, or the Western Wall.

This site of the temple was also known as the Foundation, שס, whose numeric value is 301.

In A.D. 33, upon a portion of this Rock, Jesus, the world's Saviour, was crucified. The place was then called Calvary, *Κρανιον*, the place of the skull. Its Gematria is 301.

Through the years it came to be known by another name. It was referred to as The Holy Mount at Jerusalem. They called it בהר הקדש בירושלם,

whose Gematria is 1204. A square with sides of 301 will have a perimeter of 1204. I do not think it is a coincidence. I think it is part of the awesome Number Code that God has planted in His word.

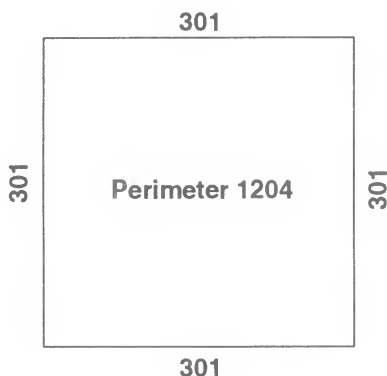

- 1204 = The Holy Mount at Jerusalem
- 301 = Calvary
- 301 = The Rock
- 301 = The Foundation
- 301 = Lambs
- 301 = Ornan
- 301 = Moon

Wow! Let me catch my breath! This use of Gematria in the Bible is awesome! But there's more!

There was yet another name for that marvelous hill—the meeting place between God and man. It was also called Golgotha. In the New Testament it is spelled *Γολγοθα*. It has a numeric value of 186.

Jesus' last words, as He was dying upon that cross was "*It is finished.*" In Greek it is spelled *γεγονεν*, and it has a numeric value of 186.

Out of curiosity I multiplied 301 by the Golden Proportion, and when I looked at the answer on my calculator, the tears began running down my face. I had stumbled upon something profound! The answer was 186. All of the names and events pertaining to that very special hill relate to a Golden Rectangle. I like to call it The Golden Rectangle of His Passion.

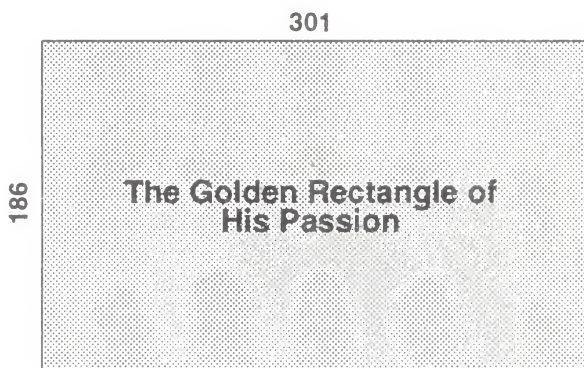

301 = Calvary
186 = Golgotha
186 = It is finished

The moon, in Greek, also bears the number 301. And the moon was vitally involved in the events of that afternoon, for at the exact time when Jesus died, the moon began to eclipse. This meant that the shadow of the earth was obscuring the light of the sun that was being reflected off of the moon. As the moon rose over Jerusalem that night, it was still in eclipse for 17 minutes.

Surprisingly, this proportion that exists between the numbers 301 and 186 is also earth-commensurate. The combined radii of earth and moon will produce a right triangle with earth's equator. Using this precise proportion, the earth and moon can define a right triangle using these two numbers. But when we do this little exercise in geometry, we come face to face with the astounding fact that the third side of this triangle bears the name Jesus Christ. Bear in mind that the diagram below is not using actual measurements for the earth and moon, it is using proportionate measures. When we use the actual measurements, the results are equally as awesome.

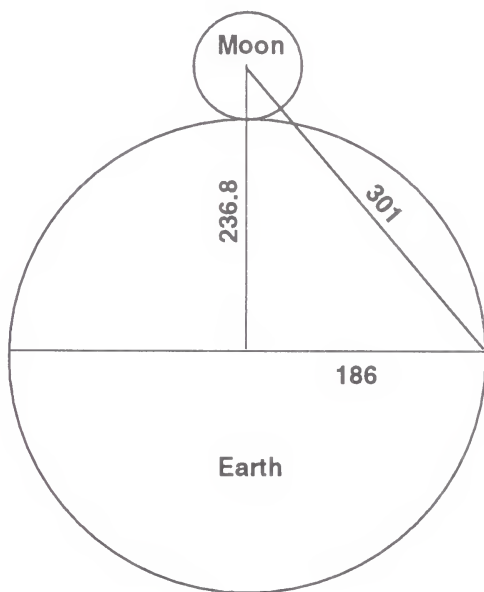

301 = Calvary
186 = Golgotha
236.8 = Jesus Christ

Now let's look at this diagram again, but this time using the actual measurements of earth and moon. And we'll include the combined diameters.

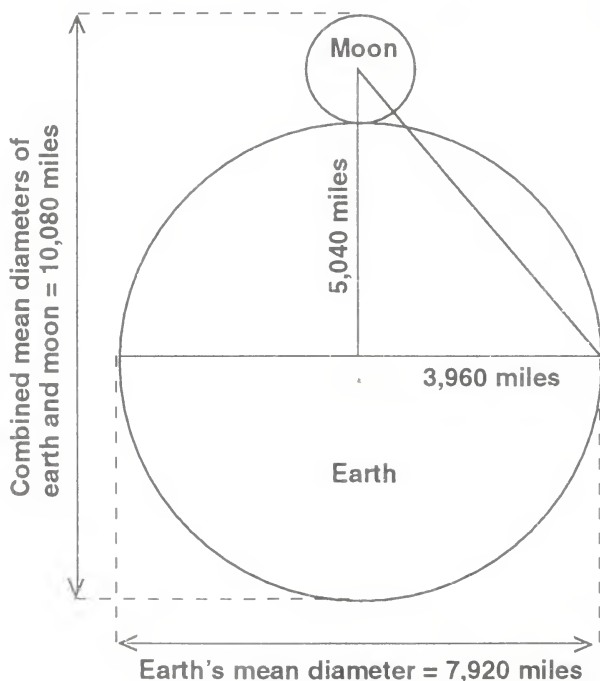

- 10080 = He shall be great and shall be called the Son of the Highest, and the Lord God shall give Him the throne of David. (Luke 1:32)
- 792 = Lord Jesus Christ (in Hebrew)
- 792 = Salvation (in Hebrew)
- 396 = Salvation (in Hebrew)
- 504 = They pierced My hands and My feet (Psalm 22:16)
- 504 = The house of David (Amos 9:11) (Prophetic of Jesus as the king on David's throne.)
- 5040 = The kingdom of our Lord and His Christ (Rev. 11:15)
- 504 = My salvation (Isaiah 56:10) (By multiplication)
- 504 = Saviour (Isaiah 45:15) (By multiplication)
- 504 = Christ (Greek) (By multiplication)

The numbers are indeed impressive. They were nothing that man has contrived. They were placed there by the One who formed the earth and man upon it – the One who brought salvation. He is the One who brought deliverance from the distress into which the race of Adam had been plunged because of sin. What a Saviour!

Observe what happens when we divide the mean diameter of the earth by the combined diameters of earth and moon.

$$\frac{7,920}{10,080} = .786$$

The square root of the Golden Proportion is .786

$$\sqrt{.618} = .786$$

- 786 = Deliverance, *התשועה*, (Jud. 15:18)
 786 = The Salvation, *ישועת*, (Isa. 26:18) (multiplies to 504)
 786 = The Salvation, *ישערת*, (Psa. 53:7) (multiplies to 504)
 786 = His Salvation, *ישעתו*, (Deut. 32:15) (multiplies to 504)
 786 = You save, *תושיע*, (Hab. 1:2) (multiplies to 504)
 786 = You may be saved, *תושעי*, (Jer. 4:14) (multiplies to 504)
- 786 = Desolations, *משמרת*, (Isa. 15:6)
 786 = Desolated, *שממרת*, (Isa. 49:8)
 786 = I shall cry for help, *שועתי*, (Hab. 1:2) (multiplies to 504)
 786 = I cried for help, *שועתי*, (Jonah 2:3) (“From the belly of Sheol I cried for help.” Jonah in the stomach of the fish represented man in the death condition.) (multiplies to 504)
- 786 = Out of our distress, *מצרתנו*, (“Out of our distress you shall hear and save.” II Chron. 20:9)

The number 786 appears, at first glance, to defy the established number patterns found over and over in the Number Code. This puzzled me, for the patterns are a mathematical evidence for the authenticity of the Code. However, it is composed of three numbers which are linked with man, the cosmos, and his Maker.

In the science of Gematria, numbers can be reversed and still add or multiply to the same number. They can even be scrambled and will still add or multiply to the same number. Realizing this to be an inherent principle of Gematria, I wondered what would happen if we combined these three numbers in all the possible ways, then obtain their total and their average. Through working with Gematria for many years, I had observed that this little exercise in arithmetic produced some astounding things. So I tried it with 786. Since it is a three digit number, there are six ways in which those three digits can be written.

$$\begin{array}{r} 786 \\ 768 \\ 876 \\ 867 \\ 678 \\ + 687 \\ \hline 4662 \end{array} \div 6 = 777$$

The number 6 pertains to the earth and man. Six is the number of the cosmos. The Greeks called it the *Hexad*. It defines structure-function-order and space-power-time. Six is a perfect number in that it is the sum of its factors; but more than this, it is unique because it is also the product of its factors. In other words, $1 + 2 + 3 = 6$ and $1 \times 2 \times 3 = 6$.

In *A Beginner's Guide to Constructing the Universe*, Michael S. Schneider makes the following observation¹:

The patterns by which the cosmic creating process constructs the universe are consistent on all levels. Wherever efficient structure-function-order is required the Hexad appears.

The number six is the basis upon which our home, the earth, receives its life-giving essence from the sun.

Diameter of the sun: $864,000 \div 6 = 144,000$

Diameter of the earth: $7,920 \div 6 = 1,320$

Diameter of the moon: $2,160 \div 6 = 360$

Speed of earth's orbit around the sun: 66,600 m.p.h.

The speed at which light comes to us from the sun is rounded to 186,000 miles per second. Divide this by 6 and the result is 31,000. The number 31 is

1 Michael S. Schneider, *A Beginner's Guide to Constructing the Universe*, Harper-Collins, New York, NY, 1994, p. 200

the Gematria for the original name of God, before the works of creation. *El*, 78, has a numeric value of 31.

This is merely a brief tip-toeing through a vast and complex subject, but it is sufficient to show the consistent meaning of the number 6.

The number 7 in the Bible has reference to the spirit and the spiritual realm. It is a number used often in the book of Revelation. The relationship of 7 to the rest of the digits is an odd one. It doesn't really relate at all; it sort of sits by itself, as if it were outside the pattern of digits. The Greeks called it the *Heptad*.

Sometime when you're playing with a calculator, try finding numbers that are evenly divisible by all 9 digits. The problem will always arise when 7 is the divisor. The lowest possible number that will divide evenly by all 9 digits is 2520. Not until we reach 2520 will 7 relate to the rest of the digits. It is not part of the earthly realm, but is spiritual.

Seven is a process – it is a means by which 8 is reached. The number 8 is the New Beginning. And for the student of Gematria, it is the New Beginning through Jesus Christ. He left the spirit realm (number 7) and came to earth to redeem man. Just like the musical scale, after seven has been completed, it reverts back to a new beginning with the number 8. Jesus provided this new beginning for mankind when He hung upon that cross – an opportunity for a new life, a resurrection.

He was the great number 8 who hung upon the cross, offering Himself in place of Adam. But when He was laid into the grave, the 8 was laid on its side – it becomes the symbol of infinity. His death had provided everlasting life for man.



A New Beginning



Infinity (Everlasting life)

By adding together all the possible 3-digit numbers that can be composed by 6, 7, and 8, then obtaining the average, we arrived at the number 777. When a digit is raised to its triplet, it is the ultimate manifestation of the meaning of the number. Here are some of its Gematria:

777 = Love of God, *αγαπης Θεου*, (Romans 8:39)

777 = I (Jehovah) have raised Him (Jesus) up,
אֲנֹכִי הֵעִירְתִּהוּ, (Isaiah 45:13)

777 = He is exalted in power and justice,
שָׁנֵא כַח וּמִשְׁפָּט, (Job 37:23)

Yes, Jesus' earthly ministry, from Bethlehem to Golgotha, leaves an awesome trail of evidence. It reveals the relationship between Jesus as the Word of God by whom all things were made, and the world that He made. It reveals the relationship between that Maker and the Babe who was born of the virgin in Bethlehem. And it reveals His supreme sacrifice which He willingly offered for us on the cross of Calvary. What a Saviour!

But there's more! The Number Code also relates to the counting of time.

Light, Time and the Number Code

God instructed Moses to have the Israelites celebrate seven very special festivals every year. He even gave Moses a new calendar by which to set the dates for these events. Their old calendar had begun in the autumn, but God told Moses:

“This month shall be the chief of months for you; it shall be the first of the months of the year for you.” (Exodus 12:2)

He was talking about the month of Abib, which later became known as Nisan. On the tenth day of Abib the people were to select a lamb – one for each household – and keep it until the fourteenth day. On that day, at 3:00 in the afternoon, they were to kill the lamb. The blood from the lamb was to be sprinkled around the doorframes of their houses.

It was a frightful night. The last of ten plagues was being sent upon Egypt that night, and Moses had been told that all the firstborn of man and cattle would be killed. The only ones to be spared were the first-borns in the houses with the blood of the lamb on the door.

That night they were to roast the lamb and eat

it, with unleavened bread. It became known as the Passover. It was the first of seven very special festivals which spanned a period of 186 days.

From the day of Passover, 14 Nisan, to the great eighth day of the Feast of Tabernacles was 186 days inclusive. Tabernacles was a seven-day festival with great rejoicing and celebration. It pictured earth's great Millennium when the Kingdom of Jesus Christ will flow out from Jerusalem to all the world.

The prophet Zechariah was instructed to write concerning this great festival. He wrote:

“And it shall be, everyone who is left from all the nations which came against Jerusalem shall go up from year to year to worship the King, Jehovah of hosts, and to keep the Feast of Tabernacles.” (Zechariah 14:16)

And, just as the seven days of the Feast of Tabernacles was followed by the great eighth day, so will earth's great Millennium, the great Seventh Day, be followed by the great Eighth Day which John saw in vision. He described it for us in Revelation 21:

“And I saw a new heaven and a new earth: for the first heaven and the first earth were passed away; and there was no more sea. And I John saw the holy city, new Jerusalem, coming down from God out of heaven, prepared as a bride adorned for her husband. And I heard

a great voice out of heaven saying, Behold, the tabernacle of God is with men, and he will dwell with them, and they shall be his people, and God himself shall be with them, and be their God. And God shall wipe away all tears from their eyes; and there shall be no more death, neither sorrow, nor crying, neither shall there be any more pain: for the former things are passed away. And he that sat upon the throne said, Behold, I make all things new.”
(Revelation 21:1-4)

The remainder of chapter 21 goes on to describe that great Eighth Day, which is the New Beginning that was secured through the blood of Jesus Christ. Then in chapter 22, verse 4, it says:

“And there shall be no more curse: but the throne of God and of the Lamb shall be in it.”

The numeric value of the phrase, *“And there shall be no more curse”* is 186. It is no coincidence. It is part of the beautiful and intricate Number Code of the Bible. It is describing the end of the time pictured by the Feast of Tabernacles, and the beginning of the great Eighth Day. From Passover to this great Eighth Day at the end of Tabernacles is precisely 186 days.

In the autumn of the year just previous to His becoming the Passover Lamb, Jesus went up to Jerusalem at the time of the Feast of Tabernacles. He

did not go up on the first day, but rather, waited until the fourth day. Then when the great Eighth Day came, He stood up and said:

“If anyone is thirsty, let him come unto me and drink.” (John 7:37)

What a strange thing to say. Perhaps many did not understand the meaning of His words. And why did He wait until the fourth day to go up to Jerusalem, and then wait until the Eighth Day to make this proclamation?

Likely it was because of the fact that the Eighth Day would be the time when the *“water of life”* would flow freely to all who would come to drink. In Revelation 22:17, describing God’s great Eighth Day, we find the invitation:

“Let him that is athirst come. And whosoever will, let him take the water of life freely.”

Isaiah had foretold the coming of this day, and he expanded on the idea:

“Ho, everyone who thirsts, come to the water; and he who has no silver, come buy grain and eat. Yes, come buy grain, wine and milk without silver and with no price.” (Isaiah 55:1)

On the scale of a thousand years equals one day, we can see that Jesus came to the feast on the fourth day, but gave this invitation on the Eighth Day. Thus,

in reality, it was in the 4000th day that He came to earth and became the great Passover Lamb. And on the 8000th day He will give the invitation to come and drink of the water of life. The time between these two events is represented by the 186 days from Passover to the Eighth Day of Tabernacles.

1860 = And there shall be no more curse (Rev. 22:3)

Jesus, the Passover Lamb died Nisan 14 at Calvary.

Eighth Day of Feast of Tabernacles is 186th day from Nisan 14

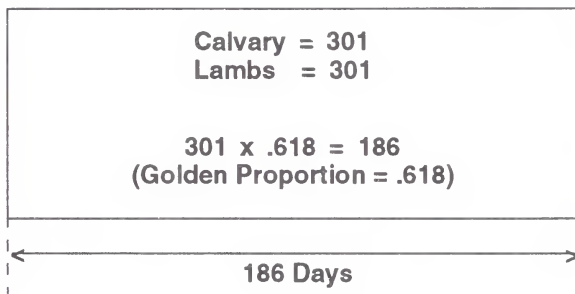

- 186 = Golgotha, Γολγοθα
- 1860 = Firstborn, πρωτοτοκον
- 186 = It is finished, γερονεν
- 1860 = And there shall be no more curse,
και παν καταθεμα ουκ εσται ετι,
(Rev. 22:3)

This display of the relationship of Gematria to time is indeed astounding! It does not stand alone. As has been shown in chapter 3, these two numbers – 301 and 186 – have a proportional relationship to the

size of the earth and its moon, and the name of Jesus Christ, 2368¹.

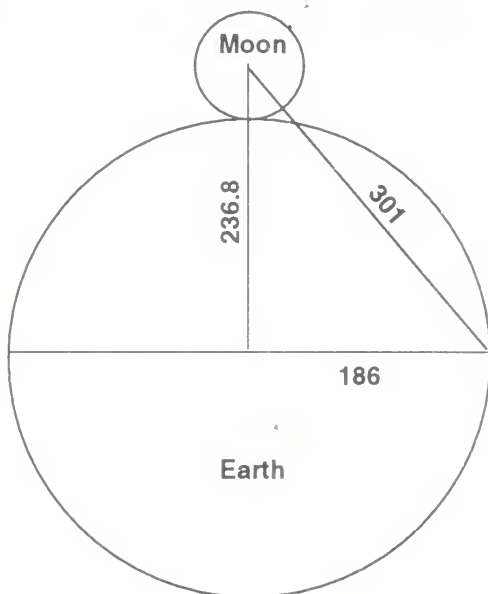

301 = Calvary
186 = Golgotha
236.8 = Jesus Christ

The moon was full that evening of Nisan 14, when the antitypical Passover Lamb hung on the cross of Calvary – the hill called Golgotha. As it rose over Jerusalem it probably appeared blood red, for it was in eclipse.

The number value for Calvary also bears an

¹ The base angle formed by this relationship of earth to its moon is identical to the base angle of the Great Pyramid in Egypt, *i.e.* 51° 51'. See Appendix 4.

interesting relationship to the Passover and the time between the typical Passover and its fulfillment, the antitypical Passover, Jesus Christ.

There were 1,480 years (inclusive) between the killing of the first Passover lamb and the killing of the antitypical Passover Lamb, Jesus Christ, on Calvary. Using the same mathematical principle that we used with the number 786 in chapter 3, we find that the number 301 reveals some remarkable evidence of divine purpose in its planning.

$$\begin{array}{r}
 301 \\
 103 \\
 031 \\
 130 \\
 310 \\
 + 013 \\
 \hline
 888 \div 6 = 148
 \end{array}$$

- 301 = Calvary, *Κρανιον*
- 301 = Moon, *σεληνη*
- 888 = Jesus, *Ιησους*
- 6 is the number relating to man and the earth
- 148 = Passover, *Πסח*
- 1480 = Christ, *Χριστος*
- 148 = Blood, *חצן*

1,480 years (inclusive) from first Passover to Jesus's death on Calvary.

It is yet another display of the awesome relationship of the Number Code to time. But there's more!

The number of days in the solar year is 365.242. That is the length of time it takes the earth to complete one orbit of the sun. During this orbit, the earth revolves on its axis 365.242 times, giving us that many days and nights. This relationship is our Solar Clock.

Let's consider a square with sides of 365.242. There is in fact a square with this measure, and it does indeed relate to the earth's orbit of the sun. It is the square base of the Great Pyramid in Egypt. The topstone of this pyramid represents the sun, and its square base represents earth's orbit around the sun.¹ The full measure of each side of its base is 365.242 Pyramid cubits, making the full perimeter 36524.2 Pyramid inches. The Pyramid inch is nearly identical to the British inch. But for the illustration below, I'm talking about *time*: the number of days in one orbit of the earth around the sun.



One side of square = 365.242

1 See *Stonehenge and the Great Pyramid, Window on the Universe*, by Bonnie Gaunt, page 54 for a description of this relationship.

Re-define that square as a circle, and it will have a circumference of 1,460. This is not the “squaring of the circle.” It is simply using the perimeter of the square and re-shaping it into the form of a circle.

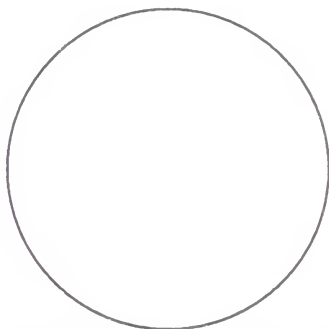

Circumference of circle = 1460

- 146 = Jehovah-nissee (The Lord is my Banner)
יהוה נסי, (Exodus 17:15)
- 146 = The King Jehovah, למלך יהוה,
(Zech. 14:17)
- 1460 = Thou, whose name alone is Jehovah, art
the Most High over all the earth, כל הארץ
על אתה שמך יהוה לברך עליון על
(Psalm 84:18)
- 1460 = Heavenly Father, πατηρ ο ουρανιος,
(Matthew 6:14)

Notice that all the occurrences of 146 appear to have reference to God the Father. He is indeed the Author of creation. John told us that it was the Word, who was with the Father, who was the agent through whom all things were made. The Father was the Author and the Son was the Workman.

Using the above circle, the next step in this mathematical sequence is to draw a square tangent to the circle (touching on all four sides). Then redefine that square as a circle. The square and the new circle will have a perimeter of 1,860.

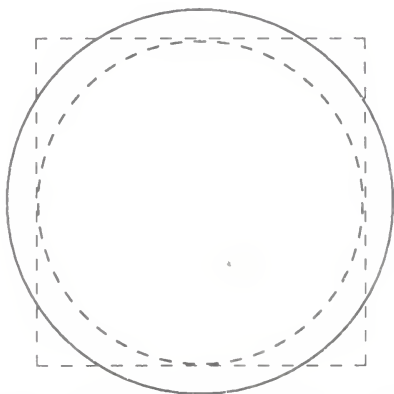

Larger circle: Circumference = 1860

186 = Golgotha

186,000 mps = speed of light

The final step in this sequence is to draw a square tangent to the outer circle. The perimeter of this outer square will be 2,368. By this simple demonstration of geometry we observe the relationship of earth's orbit of the sun to both the Father and the Son, and the speed of light. Bear in mind that 365.242 days is not defining distance, it is defining *time*. Likewise, the speed at which light comes to us from the sun, is not distance, it is *time*. Thus is demonstrated a fundamental relationship between the Number Code of the Bible

and *time*. As well as the beautiful relationship of both the Father and the Son to the creation of our solar system. For those who desire to do the math, you will find the numbers have been rounded.

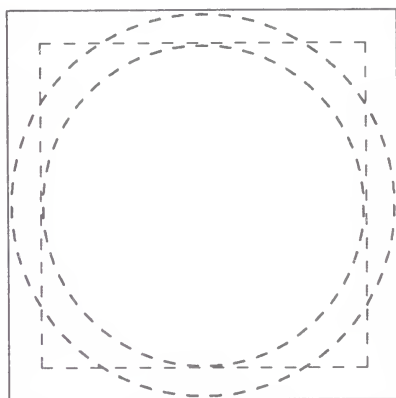

Perimeter of large square, 2,368

2368 = Jesus Christ

The relationship of light to time is indeed worthy of another look. In the Number Code, “time,” ערך, has the value of 124. “Light,” φως, has a numeric value of 1500. When we multiply light by time we get the speed of light: $124 \times 1500 = 186,000$. Just one of the Number Code’s magnificent gems!

Time	x	Light	=	186,000
124		1500		

When Isaiah told us that a child would be born whose name would be called Wonderful, he began by saying:

“The people who walk in darkness have seen a great light; they who dwell in the land of the shadow of death, Light has shone on them.” (Isaiah 9:2)

That Great Light, was, of course, Jesus. The “*land of the shadow of death,*” in the Masoretic Text, is translated “*Land of the death shadow.*” Indeed the death shadow has fallen over the entire Adamic race because of sin. But Isaiah also prophesied of a time when that death shadow will be removed:

“And He will destroy in this mountain the face of the covering which covers all people, and the veil that is woven over all nations. He will swallow up death in victory! And the Lord Jehovah will wipe away tears from all faces. And He will remove the reproach of His people from all the earth – for Jehovah has spoken.” (Isaiah 25:7-8)

This is the purpose for which Jesus came. John said that

“He was the true Light, which lighteth every man that cometh into the world. He was in the world, and the world was made by Him, and the world knew Him not.” (John 1:9, 10)

John called Him the “*True Light*,” and Isaiah called Him the “*Great Light*.” The Great Light is the One who dispells the death shadow; in fact, He not only dispells it, he removes it completely.

250 = Great Light, אור גדול, (Isaiah 9:2)

That Great Light is represented by the entire circuit of the sun through all the twelve signs of the Zodiac, which requires 25,920 years for completion. It is called the Great Year. Those heavenly signs tell the whole story of the plan of God for the salvation of man through Jesus Christ.¹ And it is remarkable indeed that the Hebrew letters which spell “*Great Light*,” when multiplied, produce 25920.

25920 = Great Light (by multiplication)

Thus the relationship of the Number Code of the Bible to time, takes on magnificent proportions – it is commensurate with the entire Precession of the Equinoxes.

In the Number Code, the relationship of this Great Light to the speed of light produces the identification of the One who came as that Light.

1 For a complete record of these signs and how their Gematria tells the whole story of the plan of God for the salvation of man, see *The Coming of Jesus: the Real Message of the Bible Codes*, by Bonnie Gaunt.

$250 \times 186,000 = 4650$ dropping the zeros
250 = Great Light
186,000 miles per second – speed of light

Circumference = 4650

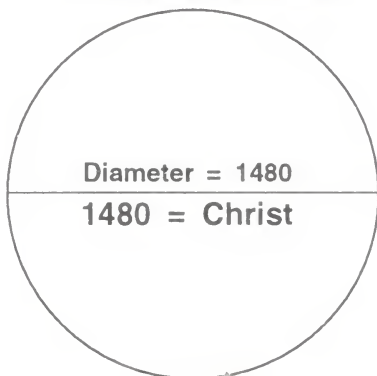

$250 \times 1,116 = 2790$ dropping the zeros
250 = Great Light
11,160,000 miles per minute – speed of light

Circumference = 2790

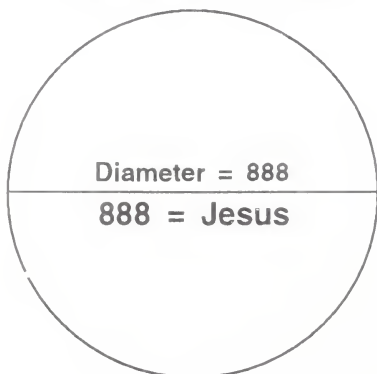

Pythagoras said, "Numbers are the language of the universe." He spoke a great truth. Those numbers which Pythagoras found in the universe, are the same numbers found in the Bible. It is the positive identification of the One who is the Author of both.

The Psalmist wrote:

"Through Jehovah's Word the heavens were made, and all their host, by the breath of His mouth." (Psalm 33:6)

John told us that the Word was the One who was with God from the beginning, and that He made all things.

Isaiah stretched our minds to the incomprehensible when he wrote:

"To whom then will you liken God? or what likeness will ye compare to him? Have ye not known? Have ye not heard? Hath it not been told you from the beginning? Have ye not understanding from the foundation of the earth? It is he that sitteth upon the circle of the earth...; that stretcheth out the heavens as a curtain, and spreadeth them out as a tent to dwell in... Lift up your eyes on high, and behold who hath created these things, that bringeth out their host by number..." (Isaiah 40:18-26)

The laws of number are the basic laws of creation – numbers are indeed the building blocks that form

our universe. And they are the numbers in the Gematria of God's written word. They have the same Author!

The demonstration below has all the earmarks of divine planning and authorship. It shows the relation of light from the sun to Jesus being the light of the world. And when I find these evidences of divine authorship, I realize that I am merely scratching the surface of a vast and deep mine, filled with priceless gems, that is seemingly endless.

Light travels a mean distance of about 93 million miles from the sun to the earth. With each revolution of the earth, it is completely bathed in sunlight. Without this light from the sun, no life could exist on our planet. We are totally dependent upon this light for our very existence.

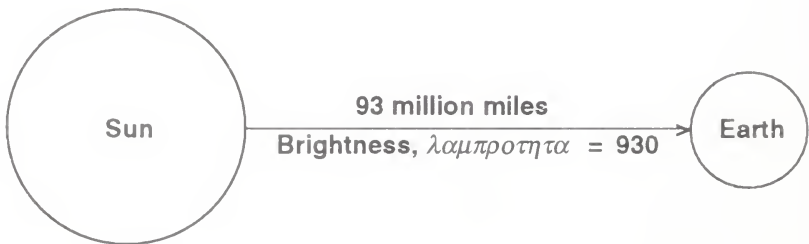

Convert the 93 million miles to inches, then divide that figure by the speed of light. If all the zeros are dropped as we do the calculation, the final result will be 3168, which is Lord Jesus Christ. Try it on your calculator. It is absolutely marvelous!

$$\begin{aligned}
 93 \times 528 &= 49104 \\
 49104 \times 12 &= 589248 \\
 589248 \div 186 &= 3168 \\
 \text{Lord Jesus Christ} &= 3168
 \end{aligned}$$

Try the same idea again, but this time instead of dividing by the speed of light, divide by the circumference of the earth, for that is the surface that is bathed in light with each revolution of the earth on its axis. The result will be 2368 dropping zeros and decimal points. It is the name Jesus Christ!

$$\begin{aligned}
 93 \times 528 &= 49104 \\
 49104 \times 12 &= 589248 \\
 589248 \div 24883.2 &= 2368 \\
 \text{Jesus Christ} &= 2368
 \end{aligned}$$

Ancient Israel had a very special kind of light. It consisted of two stones that were attached to the breastplate of the high priest. They were called the Urim and Thummim. If the high priest needed to ask a question of God, he would go into the Tabernacle, wearing this breastplate, and ask the question. The answer would be indicated by the lights that would appear in the stones.

When Nebuchadnezzar's army invaded Jerusalem in 586 B.C., the temple was destroyed. From that

time onward, the high priest had no Urim and Thummim with which to receive answers from God. Seventy years later, when Cyrus gave permission for the Israelites to return and rebuild their temple, they had no Ark of the Covenant, no priestly garments, no breastplate, and no Urim and Thummim.

In the book of Ezra it is recorded that those of the priestly line who could not find their genealogical records, would have to wait until a priest appeared who had a Urim and Thummim, before they could partake of the priests portion.

“And the governor said to them that they should not eat of the most holy things until there stood up a priest with Urim and Thummim.” (Ezra 2:63)

This obscure bit of information might go completely unnoticed if it were not for the amazing Gematria it contains.

888 = A priest with Urim and Thummim,

כהן לאורים ולתמים

888 = Jesus

Apparently the Priest with Urim and Thummim is prophetic of Jesus at the time when He is a priest and king upon the throne of David. It appears to be prophetic of a time when there will once again be communication with God. Isaiah prophesied of a time

when communication with God would be vibrant and open – in the time of the Kingdom that will flow forth from Jerusalem to all the world. He will no longer be a God *“who hides himself.”*

“And it will be before they call, I will answer; while they are speaking, then I will hear. The wolf and the lamb shall feed as one, and the lion shall eat straw like the ox.” (Isaiah 65:24)

Thus we have seen that the Number Code does indeed relate to both light and time. With that discovery, let's pursue the probe into time and look for evidence that might give insight into the chronology of man, and especially where we are today on God's time-clock. It is an awesome task, and one that can only provide positive proof after the fact. Only hindsight can be 20-20.

So, it is with an unsure footing that I dare to explore the path. Yet it lures me on with such enticing yet elusive treasures, that I am helpless to resist.

The study of chronology has been a life long passion. And the study of Gematria has been an on-going pursuit for half a lifetime. I cannot resist the lure of the journey.

Many years of in-depth search into the history of man, his recording of events, and their date relationships to astronomical phenomena, has brought me to the conclusion that we are living in a pivotal point in the chronology of man – the ending of a long period of

6,000 years, and the beginning of the seventh.

On December 31, 1999, as the earth whirled into each of its 24 time zones, the celebrations were magnificent. For a few brief hours; the peoples of the world were united as one, with a common joy, with a common hope, and with a common bond never before experienced. Oh that it could be captured and put into a bottle, and fed to a world hungry for peace and harmony and love! I believe that most of the celebrants were unaware of the real specialness of the time.

With Rosh Hoshanah of 1999 we have entered into a year that completes 6,000 years from the creation of Adam, and does indeed put us into a new Millennium.¹

The big debate about which year marks the true millennium is based on a quirk of the Gregorian calendar, which began, not with zero, but with A.D. 1. It is, in fact, a moot question, because man's time is properly counted from the creation of Adam.

Rosh Hoshanah of 1999 began the Hebrew year 5760. The first observation is that it is 240 years short of the necessary 6,000. True, it is. This is an acknowledged discrepancy. Even the Encyclopedia Britannica states that to convert Hebrew years to Gregorian years, add 240. Many attempts have been made to explain the difference, but no one has come up with conclusive historical evidence for the real reason. Per-

1 See Appendix 1, The Elusive Millennium Date

haps it may have something to do with the Gematria.

Soon after the Israelites left Egypt, under the leadership of Moses, God called Moses up into the mount and gave him the laws by which the people were to experience their special relationship to God. One of those laws concerned the Sabbath day. Moses was told:

“Work may be done six days; and on the seventh day is a Sabbath of rest, holy to Jehovah; everyone doing work on the day of the Sabbath surely shall be put to death. And the sons of Israel shall keep the Sabbath, to observe the Sabbath for their generations, a never ending covenant. It is a sign forever between Me and between the sons of Israel; for in six days Jehovah made the heavens and the earth, and on the seventh day He rested and was refreshed.” (Exodus 31:15-17)

While working with the Gematria of this text, I tried multiplying the numeric values of the letters in the words “*six days.*” The answer got my attention! Reading from right to left:

$$\begin{array}{c} \text{Days} \quad \text{Six} \\ \text{ם י מ י} \quad \text{ש ש ת} \\ 40 \times 10 \times 40 \times 10 \quad \times \quad 400 \times 300 \times 300 = 5760 \\ \text{(dropping the rest of the zeros)} \end{array}$$

It is quite remarkable that the surface text gives “*six days*” while the hidden text appears to be telling us that the six days will bring us to the year 5760. The Hebrew year 5760 begins near the end of our 6000th year. But how do we know that the text is telling us that each of those six days would be 1000-year days?

The Gematria of the text appears to be giving us the length of time of each of the six days. By adding the numeric values of each of the letters in the word “*six*” we get 1000.



When God gave these instructions to Moses, did He hide within it a time measure? Was He telling Moses that these six days in which man was to work would be a sign that there would be a grand week of six days – 6,000 years – which would be followed by a great Sabbath? It certainly appears that He did. And the math is accurate.

In the first chapter of Genesis, following the description of the six days of creation, we are given

one last thing that was created on the sixth day. It was man.

“And God said, ‘Let us make man in our image, after our likeness ... and let them have dominion ... over all the earth.’” (Gen. 1:26-28)

Man was given a dominion, a lease of rulership over the earth. The length of time that was to be given to man for this rulership was not stated here. However, it was given in Genesis 6:3 at a time when the destruction of man was about to happen in the great deluge. God told Noah:

“My spirit shall not always strive with man, for that he is flesh: yet his days shall be a hundred and twenty years.”

When we consider the time and circumstances under which this was said, it does indeed seem strange that God would tell Noah that man’s days would be 120 years, when man at that time was living on average over 900 years. Noah, himself, was 600 years old at that time. So it does not appear that God was telling Noah how long his life-span would be. Perhaps He was indicating to Noah the length of time that man would have dominion. *“His days”* could possibly have been man’s days of rulership on the earth.

It may be that these 120 years that were allotted to man are Jubilee years. Israel’s Jubilee years were counted on a cycle of 49, with the first year of the next

cycle being the 50th, or Jubilee. However, this was given to Noah long before the Jubilee cycles were given to Israel. A Jubilee year is a 50th year, regardless of the method of counting. And 120 of them would be 6000 years. Were these man's "days" that God said were allotted to him? If so, then the Hebrew year 5760, which begins in the Gregorian 6000, would see the expiration of that lease of rulership.

Using the ELS Code (Equidistant Letter Sequence), there appears to be confirmation of this concept. In showing this below, I do not show the rest of the Hebrew letters that appear in the matrix. They only serve to confuse the illustration. Only the words and letters that are involved in the code are shown. This is found in Numbers 3 and 4.



This remarkable matrix suggests that the “appointed time” for “man’s days” would be counted by “Jubilees,” which would produce “6000 years,” bringing us to the year “5760.”

If this analogy is correct, then perhaps man’s lease of power as earth’s ruler expired on Rosh Hoshannah of 1999, which began the Hebrew year 5760. But man is definitely still ruling. Is he now ruling by right, or by usurpation? And if his lease of rulership has expired, to whom does it rightfully belong?

My suggested answer may or may not be correct, but it appears to fit the scriptures. In the book of Revelation, chapter 5 we are told:

“And I saw in the right hand of him that sat on the throne a book (scroll) written within and on the backside, sealed with seven seals. And I saw a strong angel proclaiming with a loud voice, ‘Who is worthy to open the book, and to loose the seals thereof?’ ”

John wept when he saw this in vision, but his tears were dried when he was told:

“Behold, the Lion of the tribe of Judah, the Root of David, hath prevailed to open the book, and to loose the seven seals thereof.”

Twice, the phrase “to loose the seals” is used here. It is interesting that the Hebrew word for “loose” is תפתח, which has a numeric value of 888. It is identi-

fyng Jesus, whose number is 888, as the one who does the loosening. This word is found in Job 38:31 where God asked Job the question, "*Can you bind the bands of the Pleiades, or loosen the cords of Orion?*"

Yes, it is Jesus – the Lion of the tribe of Judah, and the Root of David – who was the only One found worthy to loosen the seals on the scroll. Why? Because He was the One who purchased man with His own precious blood on Calvary. When He purchased man, He also purchased all of man's possessions, including the lease of dominion. It rightfully belongs to Jesus, but it must wait until man's promised time has expired. That time was to be 6,000 years. Has it expired? Very probably!

I thought of this as I watched the celebrations and the fireworks follow the midnight hour around the world. Wouldn't it be wonderful if they were celebrating and giving allegiance to the world's rightful Ruler! But, unfortunately, the rulers of earth do not give up that easily. They will not give up without a fight. The Psalmist prophesied that this would be so.

"Why do the nations swarm, and the peoples meditate on vanity? The kings of the earth set themselves; yea, the rulers have plotted together against Jehovah and His anointed (Messiah), saying, 'We will break Their bands in two, and throw off Their cords from us.' He who sits in the heavens shall laugh; Jehovah

shall mock them. Then He will speak to them in His anger; and He will trouble them in His wrath. 'Yes, I have set My king on My holy mount, on Zion.'” (Psalm 2:2-5)

The phrase “*I have set My king*” multiplies to 5760. Was He encoding, within the text, a time-frame for the event?

5760 = I have set My king (by multiplication)

5760 = Messiah the Prince (Dan. 9:25) (by multiplication).

Amazingly, the prophet Zechariah, when speaking of the coming of the Messiah, used the expression, “*Behold, your King.*” (Zech. 9:9) If we multiply the numeric values of the Hebrew letters, they will produce 6000.

About 550 years later, Jesus stood before Pilate, having been accused of proclaiming Himself king of the Jews. Pilate presented Jesus before the angry crowd and said, “*Behold your King.*” It is recorded in John 19:14:

“And it was the preparation of the Passover, and about the sixth hour; and he saith unto the Jews, Behold your King!”

At the expiration of the 6,000 years the transfer of the right of rulership takes place. If this corresponds

to the Hebrew year 5760, then we are indeed at a pivotal point in the whole history of man.

In the New Testament there are three Greek terms that apply to Jesus, which multiply to 6000.

6000 = King

6000 = Kingdom

6000 = Head (meaning Jesus)

These appear to support the concept that at 6,000 years the right of rulership would be transferred to Jesus.

If this is indeed the proper time frame, then it shows us something rather spectacular. It would place the date at which David was anointed king over all Israel precisely in the middle of the 6,000 years.

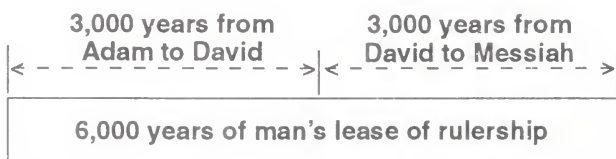

It would flow logically that the 6,000 years would be followed by a seventh thousand. It is God's grand octave of time, bringing us to the New Beginning, the great Eighth Day.

The second 3,000 years, from David to King Messiah, can be divided into three periods of 1,000 years each. Precisely at the end of the first thousand years

Jesus was born in Bethlehem. We have just passed the 2,000-year mark from that event. This would place us in the very beginning of the great seventh thousand-year day, which is also the third thousand-year day from the birth of Jesus.

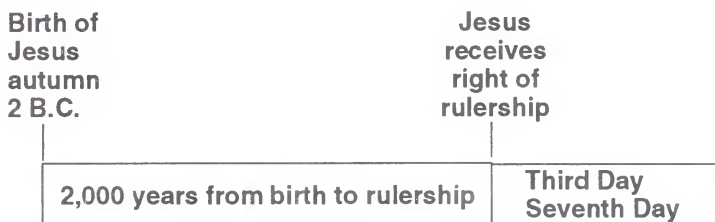

We have seen the evidence that the year 5760 comes at the end of six days. The words “*six days*” in Hebrew multiply to 5760. It is exciting to realize that the words “*third day*” in Hebrew also multiply to 5760. Perhaps it is telling us that the juncture between the close of the six days and the beginning of the great Third Day is the year 5760.

Third Day
 יוֹם תּלִּיתָהּ

$$5 \times 400 \times 30 \times 400 \times 40 \times 6 \times 10 = 5760$$

(dropping the rest of the zeros)

If the year 5760 (1999-2000 Gregorian) is in fact the year for the transfer of the right of rulership, what

might we expect to happen? I am not a prophet. I cannot make such a prediction. However, according to the sequence of events in the book of Revelation, the right of rulership was followed by the opening of the seals that had secured the scroll. As each of the first four seals were opened, horses were seen. With the first seal a white horse, the second seal a red horse, the third seal a black horse, and the fourth seal a pale horse. Many have interpreted these to be: 1. Antichrist; 2. War; 3. Famine; and 4. Death. That, of course, is an interpretation. It does not paint a pretty picture. Whatever happens, it will mean the eventual transfer of actual government from the present rulership by man to the rulership of Jesus Christ.

Following the transfer of actual rulership, the picture becomes much more beautiful. Isaiah described it thus:

“Unto us a Child is born, unto us a Son is given, and the government shall be on His shoulder; and His name shall be called Wonderful, Counselor, the mighty God, the everlasting Father, the Prince of Peace. There is no end to the increase of His government and peace. On the throne of David, and on His kingdom, to order it and to sustain it with justice and with righteousness from now on, even forever.” (Isaiah 9:6-7)

It puts the world's hopes for the near future in

focus, and that's exciting!

This "*Root of David*" who opens the seals on the scroll is the One prophesied in Isaiah 11:1:

"And a Rod proceeds from the stump of Jesse, and a Branch will bear fruit out of his roots."

Reading the words as they appear in sequential order in the Masoretic Text, "*And proceeds a shoot from the stump of Jesse,*" the numeric values add to 764. This number, divided by the Golden Proportion produces 1236. If this were drawn as a Golden Rectangle, its numbers become most spectacular.

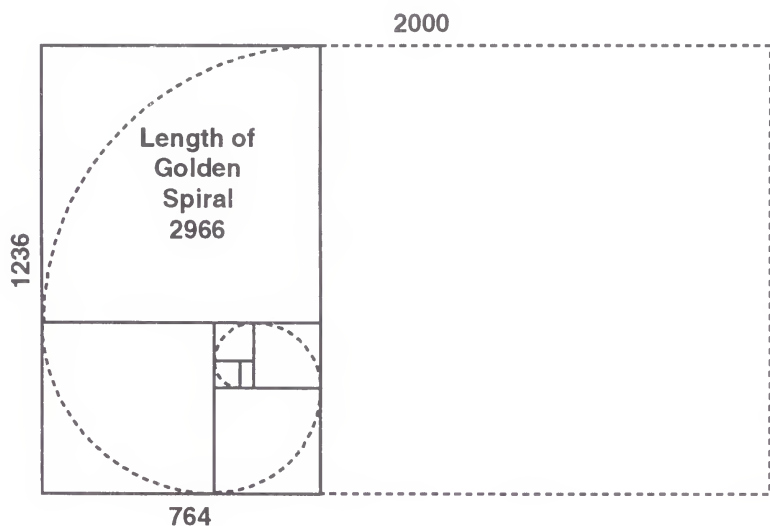

The above numbers all relate to the time of the legal transfer of the right to rule – even to the conflict that will ensue as the present rulers of earth attempt to hold on to their power, when "*the kingdoms of this*

world have become the kingdom of our Lord and His Christ." (Revelation 11:15)

The long side of the rectangle bears the number 2000. It possibly represents the two thousand years that come between the birth of the King, and the time when He legally comes to power.

When 2000 is multiplied by the Golden Proportion, we obtain the short side of the rectangle, which is 1236. The meaning of the name Immanuel – "*God with us*" – has a numeric value of 1236. Probably the reason it was prophesied that His name would be Immanuel, yet when He was born they called Him Jesus, is because the name Immanuel would be His name when He became earth's rightful ruler.

Isaiah identified Him as the "*Root out of dry ground,*" which also bears the number 1236.

Multiply 1236 by the Golden Proportion and we obtain the short side of the smaller rectangle, which is 764. The word "*tribulation,*" as it appears in the Greek text of the New Testament, *θλιψει*, has a numeric value of 764. It is fitting that this number should appear here, for the effect of the transfer of the right to rule will surely bring a time of tribulation to the world.

The Golden Spiral that can be traced on the corners of the smaller rectangle has a length of 2966. How thrilling to find that the number of years from the end of David's reign to the time of the transfer of the right to rule is exactly 2966 years. This is, of course,

based on the analogy previously shown that the Hebrew year 5760 (Gregorian 1999-2000) is the year in which this transfer legally takes place.

We live in an exciting time. Great things are happening in the heavenly realm. God's time-clock of the ages has ticked its way through six thousand years of man's history. How fitting that with the turn of the year, into the year 2000, the world was a-glow with fireworks! It was a night to remember. It was not, however, the actual beginning of the new era. That began silently with Rosh Hoshanah about three months earlier.

And silently it was – for many of us did not even know when God's Rosh Hoshanah was to occur. According to the Hebrew calendar, it was to occur on September 11, 1999. However, if we go all the way back to the instructions that God gave to Moses for the placing of the beginning of the Festival Year, the first month was to be Abib, the month of spring. The marking of the beginning of the year was to be with the first New Moon of the spring. It was only in later years that the method of determining the pattern of the Hebrew calendar changed from this original instruction to what it is today. Therefore, it left the year 1999 with an ambiguity regarding the real date for Rosh Hoshanah. Which one was the date on God's calendar? Originally, it was to be the day of the seventh New Moon. If that method of counting were used in 1999, it would have placed Rosh Hoshanah on Octo-

ber 9 or 10. Yes, it came silently, and even those who were watching with great expectation were left in wonder.

But “time” – that elusive, seemingly capricious friend, keeps on ticking. It is indeed a friend, for each day brings us closer to the long-promised Kingdom for which Jesus taught us to pray:

“Thy Kingdom come, Thy will be done on earth, as it is done in heaven.”

5

The Good Samaritan

Parables are interesting creations. Sometimes the surface meaning is obvious and beautiful, yet, if we look beneath the surface, there is often another, hidden meaning, that is quite revealing. Jesus was the Master of the parable.

One day a lawyer came to Jesus, with the intent of asking Him a trick question. Jesus answered with a great truth regarding love for our neighbors. That is what the surface text plainly reveals. But, being the Master of the parable, He used the opportunity to teach a far more magnificent truth, which He hid within its story.

The lawyer asked Him: "*Master, what shall I do to inherit eternal life?*" It sounds like a legitimate question. But he was only setting Him up for the real intent of his inquiry. Of course Jesus could read the heart, and knew what to expect. So He said to him:

"What is written in the law? how readest thou?"

Ah! That was just what the lawyer wanted. Jesus was falling right into his trap, or so he thought. Proudly he answered, "*Thou shalt love the Lord thy*

God with all thy heart, and with all thy soul, and with all thy strength, and with all thy mind; and thy neighbour as thyself."

Jesus answered: *"Thou hast answered right: this do, and thou shalt live."*

Then came the real intent of the questioner. He replied: *"And who is my neighbour?"*

Jesus, knowing that the lawyer was trying to corner Him, launched into a lengthy parable. The parable indeed answered the lawyer's question regarding the identification of a neighbor, but in so doing, He also gave us an insight into the time features of God's plan for the salvation of man.

Jesus replied:

"A certain man went down from Jerusalem to Jericho, and fell among thieves, which stripped him of his raiment, and wounded him, and departed, leaving him half dead. And by chance there came down a certain priest that way: and when he saw him, he passed by on the other side. And likewise a Levite, when he was at the place, came and looked on him, and passed by on the other side. But a certain Samaritan, as he journeyed, came where he was: and when he saw him, he had compassion on him. And went to him and bound up his wounds, pouring in oil and wine, and set him on his own beast, and brought

him to an inn, and took care of him. And on the morrow when he departed, he took out two pence, and gave them to the host, and said unto him, 'Take care of him; and whatsoever thou spendest more, when I come again, I will repay thee.' Which now of these three, thinkest thou, was neighbour unto him that fell among the thieves?"

The lawyer realized that his attempt to trap Jesus had failed. But little did he realize the real intent of the parable. It indeed teaches the basic principles of the whole story of the fall and redemption of man, and, by its Gematria, suggests its time features.

However, the lawyer undoubtedly read a subtle message regarding the priesthood, of which the lawyer may have been a member. In the parable, it was a priest and a Levite who merely looked at the traveler, and then passed by on the other side, as not wanting to become contaminated with the traveler's plight.

For purposes of identification, let's call the "certain man" who was traveling from Jerusalem to Jericho the Traveler.

Jerusalem is built in the hill country, and Jericho is down in the valley near the Jordan River. Travelers today say that there is a noticeable temperature change between Jerusalem and Jericho, and as one reaches Jericho the air becomes quite oppressive in the summer months. This is because Jerusalem is at

an elevation of about 2,500 feet above sea level, while Jericho is about 800 feet below sea level. The steep descent to Jericho is about 3,300 feet. It is a fitting picture of Adam's decent from the perfection in which he was created, to the degradation into which he fell as a result of sin.

Jerusalem
2500 feet above
sea level

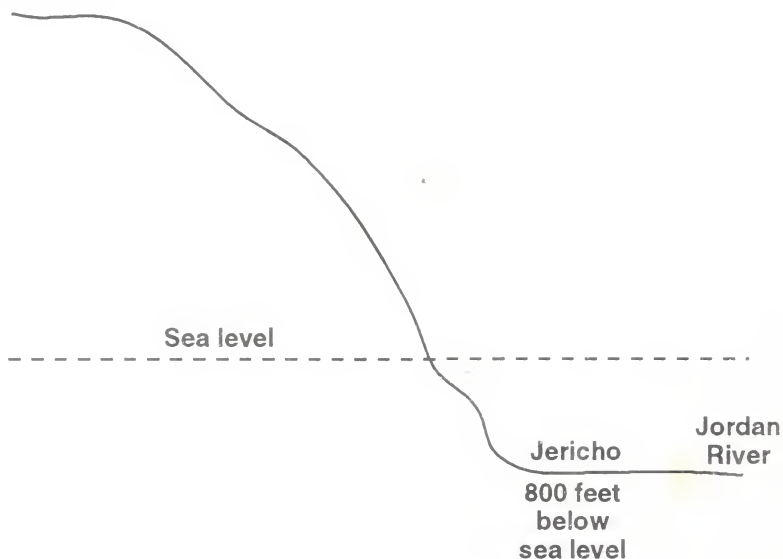

But a reversal of this is hinted at in the fact that Jesus was 33 years old when He paid the price for Adam's sin, thus it becomes a corresponding price for the descent into sin. In the Gematria of the Bible, the Hebrew word meaning "to atone" has the number value of 330. Thus the reversal of the descent from Jerusalem to Jericho would be the 3,300 feet, or the work of atonement, bringing man back into the condition that

he lost.

The Traveler fell among thieves. The thief is Satan. Adam came under the influence of Satan, who brought the temptation to disobey. And the thief stripped him of his clothes, wounded him, and left him half dead.

Clothes, in the symbology of the Bible, represent our justification. It is only as we are clothed with justification that we can be acceptable to God. Adam lost his when he sinned. And he knew it. That is why he hid from God in the Garden of Eden.

“And the eyes of both of them were opened, and they knew that they were naked, and they sewed leaves of the fig-tree and made girdles for themselves. And they heard the sound of Jehovah God walking up and down in the garden at the breeze of the day. And the man and his wife hid themselves from the face of Jehovah God in the middle of the trees of the garden. And Jehovah God called to the man and said to him, ‘Where are you?’ And he said, ‘I have heard Your sound in the garden, and I was afraid, for I am naked, and I hid myself.’ And He said, ‘Who told you that you were naked? Have you eaten of the tree of which I commanded you not to eat?’” (Genesis 3:7-11)

In the parable, the Traveler was as good as dead. If help had not come, he would have died.

While the Traveler lay there dying, a priest and a Levite came along. As they drew near, and saw the Traveler lying there, covered with blood and dirt, they moved over to the other side of the road, and hurried past, not doing anything to help him. Just so, the sacrifices of the Law, which were in the hands of the priests and the Levites, were completely unable to help fallen man or to heal his wounds.

“For the law having a shadow of good things to come, and not the very image of the things, can never with those sacrifices which they offer year by year continually, make the comers thereunto perfect. For then would they not have ceased to be offered? Because that the worshippers once purged should have had no more conscience of sins. But in those sacrifices there is a remembrance again made of sins every year. For it is not possible that the blood of bulls and of goats should take away sins.”
(Hebrews 10:1-4)

Enter: the Good Samaritan! He came along, and seeing the Traveler suffering certain death, He had compassion on him. The Good Samaritan is Jesus. He bound up his wounds, poured oil and wine on him to clean off the blood and mud, and to soothe his aching body. It describes the work of redemption. It pictures the work of the spirit (oil and wine) in transforming the sinful nature back into that which can be accept-

able to God.

The Good Samaritan put the Traveler on his “own beast,” which means that the Good Samaritan walked while the injured man rode on the donkey. It is a beautiful picture of Jesus giving himself for Adam – taking the sinner’s place. He brought the Traveler to a place where he could be cared for. It shows that the work of atonement is to heal mankind from Adamic sin.

The identification of “*His own beast*” is most interesting. The Gematria for “own” is 144 – a number that always identifies God’s realm. This means that the One who came to make atonement was in God’s realm. However, when we add the numeric values for “own beast” it totals 792. It is describing the place of salvation – the earth, whose mean diameter is 7,920 miles. The Hebrew word for “salvation” has a numeric value of 792. Thus the placing of the Traveler on His own beast is telling of the salvation of man by means of the sacrifice of Jesus. He came to earth, the place of salvation.

Own	=	144
Beast	=	648
		<hr/>
		792

7,920 miles = mean diameter of the earth

792 = Salvation, ישועות

792 = Lord Jesus Christ, אלהא יהושוע משיח

The Good Samaritan brought the Traveler to an inn so he could be cared for. He gave the innkeeper “two pence” to pay for his care, and assured him that if there were any additional costs, He would pay when He returned. The numeric value of “two pence” is also 648 – the same as the value of “beast,” thus we have the corresponding price, paid for the Traveler.

Two pence was two day’s wages. It provides a beautiful chronological significance. Two pence would be that which could be earned in two days. Could it have reference to the two days from the first advent of Jesus to the second advent? I suspect that it does. The concept of two is repeated, for although it was two day’s wages, it would be enough to care for the Traveler for two months. It was a price paid to cover the time until the Good Samaritan “comes again.” The fact that it would care for the Traveler for two months, would mean 60 days, and it may very well have reference to the entire 6,000 years from the wounding of the Traveler (Adam) to the return of the Good Samaritan.

“When I come again I will repay.” The Good Samaritan reveals here that He plans to return to get the Traveler. But what did He mean by the statement “I will repay?” It is interesting that the numeric value for “I will repay” is 2000. Is Jesus suggesting here that His return will be 2,000 years after His first advent? He appears to be associating the concept of His coming again with the concept of repaying.

Whether or not a time prophecy is implied, it is certain that Jesus indicated by this parable that He would return for the Traveler (Adam and his race). You cannot return to a place where you've never been.

Jesus said "*when I come again,*" I will repay. The Greek words used here may indicate the time of that return. The literal Greek text says "*in the return.*" The words "*in the,*" *εν τω* multiply to 6000, dropping the rest of the zeros. And "*return,*" *επαυερχεσθαι*, multiplies to 54, dropping the zeros. If not planned, it was a rather convenient coincidence. The number 54 in the Gematria of the Bible appears to have reference to the time of the end of man's rule and the time for the ushering in of the Kingdom of God. Below are a few examples.

By addition:

5040 = The Kingdom of our Lord and
His Christ (Revelation 11:15)

5040 = The ransomed of the Lord shall
return (Isaiah 35:10)

By multiplication:

504 = Seventh day, יום השביעי

504 = Until Shiloh comes (Gen. 49:10)

But with the turning of the epoch of man's allotted dominion, we are only painfully aware that man is still ruling. When will the kingdoms of this world become the "*Kingdom of our Lord and His Christ?*"

The prophecies proclaim that He will sit on the

throne of David and that He will bring righteous government to this earth. Oh how we long for that Kingdom!

The prophet Amos wrote:

“In that day I will raise up the house of David that has fallen, and will wall up its breaks. And I will raise up its ruins, and I will build it as the days of old; so that they may possess ... all nations on whom My name is called, states Jehovah who is doing this.” (Amos 9:11-12)

The Hebrew letters in *“the house of David,”* דָּוִד סֶכֶת, have a numeric value of 504. It appears to be connected numerically with the events at the beginning of the Seventh Day.

Isaiah wrote:

“And the key of the house of David I will lay on His shoulder; so He shall open, and no one shall shut; and he shall shut, and no one shall open.” (Isaiah 22:22)

What is the key?

6

The Key

We might wonder who it is that will be given the Key to the house of David, but the positive identification was furnished by Jesus, Himself, when He gave the Revelation to John. He quoted Isaiah 22:22 and applied it to Himself.

“These things saith he that is holy, he that is true, he that hath the key of David, he that openeth, and no man shutteth; and shutteth, and no man openeth.” (Revelation 3:7)

God had promised David that His dynasty would last forever. Yet David died after reigning for 33 1/2 years over all Israel in Jerusalem. Eventually, the last king of the Davidic line was taken captive and killed in the year 586 B.C. Did God’s promise fail?

It might appear so; however exactly one thousand years after David was anointed king over all Israel, another future King was born of the line of David. He lived 33 1/2 years, corresponding the the length of David’s reign in Jerusalem. Four days before His death, He rode into Jerusalem on a donkey while the people proclaimed Him king. He did not, however, use the Key of the house of David at that time, for within

four days He hung upon a cross on Calvary's hill, dying as the antitypical Passover Lamb.

But He assured John that He still had possession of the Key of David. What is the Key? A key is that which opens a door to allow entrance, and possession of all that is inside. When will He use the Key to open the door?

We get a hint from chronology, and we get a positive identification from Gematria and the Golden Proportion. The evidence is magnificent!

The Hebrew word that Isaiah used when he prophesied of the One who would hold the Key of David, is מפתח – that is the Key, and it has a numeric value of 528. Does the number have a familiar ring? Of course! We learned as children that there are 5280 feet in a mile. This is not just a coincidence. The measure of the mile unit is based upon the relationship of light and time.¹

Thus it is a startling display of the Number Code when we find that the number 528 is also the numeric value of the Hebrew word that is translated *the breaking forth of light*, כשחר. This number is again associated with light in the prophecy of Hosea. He was

1 As the earth revolves on its axis, it is bathed in sunlight once in each revolution. If the path of the sunlight were traced on the diameter of the earth (7,920 miles) it would cover 528 miles in one hour. Thus the true origin of the mile is not of man's making, but is the relationship of light to time, and to the size of the earth and the speed of its rotation.

speaking of the time when Israel will be healed. He said:

“Come let us return to Jehovah; for He has torn, and He will heal us. He has stricken, and He will bind us up. After two days He will bring us to life. In the third day He will raise us up, and we shall live before Him. Then we shall know, we who follow on to know Jehovah, His going forth is established as the dawn; and He shall come to us as the rain, as the latter (and) former rain to the earth.”
(Hosea 6:1-3)

The phrase “*as the dawn*” has a numeric value of 528. And how thrilling to find that the whole phrase, “*established as the dawn*,” כִּשְׁחַר כּוֹן, will multiply to 5760. If we look at this in the Masoretic Text, it actually reads, “*As the dawn is sure.*” What a beautiful confirmation that the dawning of the great Third Day will surely come, and that it is associated with the two numbers, 528 and 5760. The Hebrew year 5760 appears to be the pivotal date that is the juncture of the end of the 6,000-year rulership of man, and the beginning of the great Third Day, in which Jesus becomes the rightful ruler.

The prophecy states that it is after the ending of the two days, and sometime on the Third Day that Israel would be healed.

There is something else hidden within this proph-

ecy of Hosea that identifies the time and the events. Hosea wrote:

“He shall come to us as the rain, as the latter (and) former rain to the earth.”

In the Masoretic Text there is no conjunction here, it simply reads *“as the latter rain former rain,”* as if it were all one concept, or one event. And it should be noted that the *“latter rain”* is mentioned first. Why would *“latter”* come before *“former?”* It is because the *“latter rain”* is the spring rain, and the *“former rain”* is the autumn rain. Autumn was seed time, and spring was harvest time. Jesus comes at both times – first advent and second advent – and He comes as the rain, bringing the water of life. The phrase expresses the wholeness and completeness of His work. And that is exactly what is found in its Gematria. If we multiply the letter-numbers in the phrase *“as the latter rain former rain”* they produce the beautiful number 25920, which is the full number of years in the Great Year, i.e., the number of years in the grand celestial cycle of the sun through all twelve signs of the Zodiac.¹

Those Zodiac signs tell the whole story of salvation through Jesus Christ. No wonder He comes *“as the latter rain former rain.”* His work of bringing the

¹ For a complete description of the twelve signs of the Zodiac and their relationship to the redemptive work of Jesus, and to the Gematria, see *“The Coming of Jesus: the Real Message of the Bible Codes,”* by Bonnie Gaunt.

water of life to dying man is the whole picture that was planted in the heavens, long before man was even created.

The prophet Joel used this same illustration of latter and former rain. He wrote:

“Be glad then, sons of Zion (nation of Israel), and rejoice in Jehovah your God. For He has given you the former rain (autumn) according to righteousness, and He will cause the rain to come down for you, the former rain, and the latter rain in the first month (the spring rain which came in Nisan). (Joel 2:23)

In some translations the *“former rain”* is made to read *“teacher of righteousness.”* The Hebrew word *mowreh*, used here, can accurately be translated either *“teacher”* or *“former rain.”* The concept in either translation is the same in the fulfillment, for Jesus did indeed come as a Teacher of Righteousness at His first advent, during the 3 1/2 years of His ministry, but Israel did not listen. The same Teacher of Righteousness will come again on the great Third Day, and they will hear Him.

Yes, as Hosea said: *“As the dawn is sure,”* we know it will happen, just as it was prophesied. That assurance bore the number 528. It is the Key. And with that Key, Jesus opens the doors to the House of David, and occupies David’s throne. Malachi called it *“The day of His coming,”* רַמִּי אֶת-יּוֹם בְּרֹאֵוּ, whose

numeric value is 528.

The relationship of the Key to the Golden Proportion is magnificent! It tells of Jesus Christ and His kingdom of peace that will first be established in Israel, when He unlocks the door to David's throne, and from there it will flow out to engulf the whole earth. This growth process is beautifully pictured by the Golden Spiral that can be traced on the corners of the Golden Rectangle which bears His name. It grows larger by logarithmic proportions.

This concept was also made apparent in the book of Daniel. When Daniel interpreted Nebuchadnezzar's dream of the great image, representing man's governments, he told of a small stone that was cut out of the mountain without hands. This small stone smote the great image on its feet, and the whole thing crumbled and was ground to powder and the wind blew it away. The stone then began to grow. It grew so much that it filled the whole world.

He was describing the growth of the long-promised Kingdom of the antitypical David, King Jesus. It all starts with a small stone. But that stone began to grow just like the Golden Spiral, in logarithmic proportions, and will become earth commensurate.

"In the days of these kings (the kings represented by the image of gold, silver, bronze, iron and clay), the God of Heaven shall set up a kingdom which shall never be destroyed.

And the kingdom shall not be left to other people. It shall break in pieces and destroy all these kingdoms, and it shall stand forever.”
 (Daniel 2:44)

This tiny stone that is cut out of the mountain without hands is Jesus at the time when the right to rule is legally His, at the ending of the 6,000-year rulership that was allotted to man. When it smites the image (man’s governments) it begins to overthrow those governments, and as it does so, it begins to grow. The Hebrew letters in the phrase “*The stone cut out of the mountain,*” מִטְרָא אֶתְגֹרֶת אֶבֶן, has a numeric value of 1320. This number is a part of the grand design that has been encoded into the Bible by the relationship of the Golden Proportion.

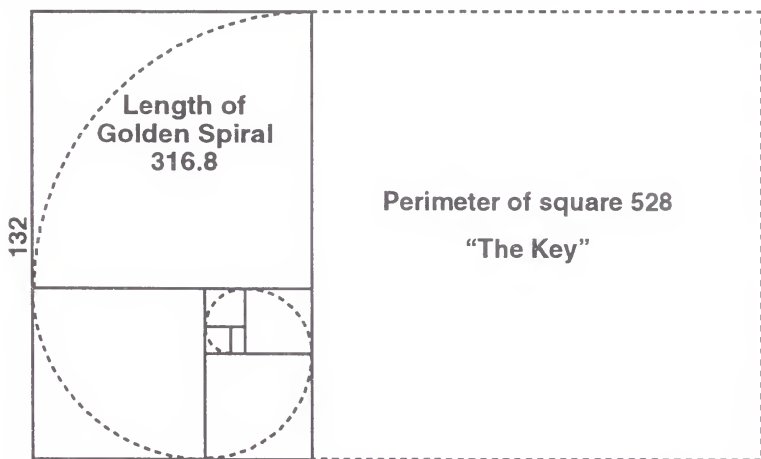

- 528 = The Key
- 528 = The Breaking forth of Light
- 1320 = The stone cut out of the mountain
- 132 = The Kingdom is the Lord's
- 3168 = Lord Jesus Christ

“The Stone cut out of the mountain” has a numeric value of 1320. Let’s make it grow by the Golden Proportion: $1320 \div .618 = 2136$. This number has magnificent meaning in the Number Code. It relates to the fact that Jesus, the root of Jesse, will be the Ruler, and the standard of righteousness will be His.

“And it shall be in that day that the root of Jesse shall stand as a banner of the people.”
(Isaiah 11:10)

This beautiful prophetic description of Jesus as the root of Jesse and as the banner for the people, adds to 2136. It is no mistake! Nor is it coincidence. It was planned by a Master Mathematician.

The conditions of that Kingdom were described in beautiful pictorial language by the prophet Joel.

“And it will be in that day, the mountains shall drop down new wine and the hills shall flow with milk, and all the streams of Judah shall flow with waters.” (Joel 4:18)

This beautiful description of the Kingdom of Jesus Christ has as total numeric value of 2136. I never cease to marvel!

His position as the ruler of that Kingdom was spoken of by the Apostle Paul in his letter to Timothy. He called him *“The blessed and only Potentate.”* It is not surprising that the Greek letters in this title also

add to 2136. That number describes that Kingdom as it grows to fill the whole earth.

We can now put this number in its rightful place as the measure of the Golden Rectangle that contains The Key, the Stone cut out of the mountain, and Lord Jesus Christ.

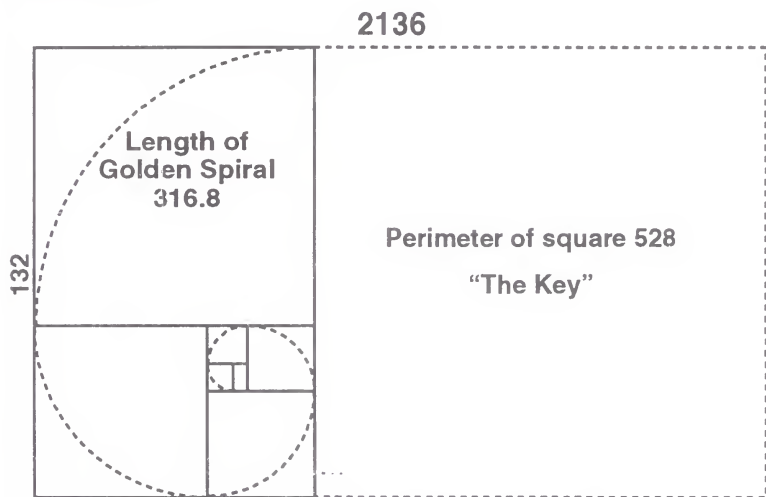

2136 = And it shall be in that day that the root of Jesse shall stand as a banner of the people. (Isaiah 11:10)

2136 = And it will be in that day, the mountains shall drop down new wine and the hills shall flow with milk, and all the streams of Judah shall flow with water. (Joel 4:18)

2136 = The blessed and only Potentate (I Timothy 6:15)

Let's take this growth by the Golden Proportion one step further, and see how that tiny Stone will fill the whole earth.

If we divide 2136 by the Golden Proportion, we arrive at the beautiful number 3456. ($2136 \div .618 = 3456$). This number is found often in the Gematria of the Bible and the dimensions of the created universe. It carries the thought of completeness. In this Golden Rectangle shown below, it pictures the fullness and completion of the plan of God for the salvation of man in Jesus Christ, and the time when His Kingdom covers the earth.

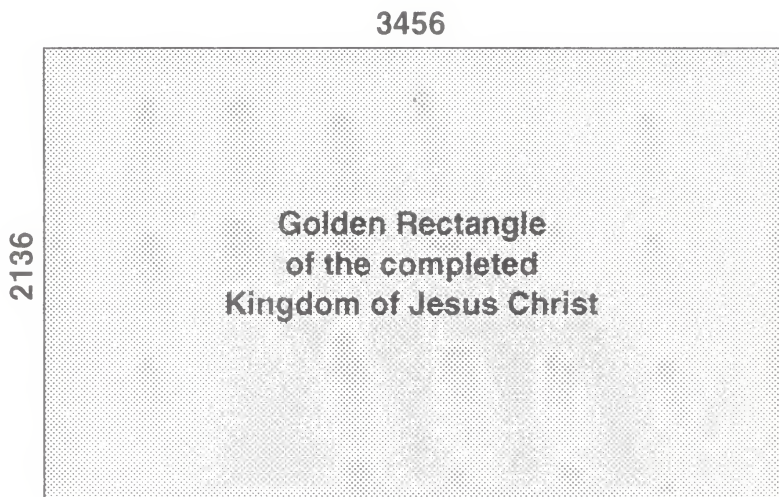

**3456 = Alpha and Omega, the beginning and the end,
(Revelation 1:8)**

3456 = His Kingdom, (Psalm 145:13) by multiplication

3456 = His dominion, (Psalm 103:22) by multiplication

**3456 = His throne in the heavens, (Psalm 103:19) by
multiplication**

3456,000 miles = a square drawn around the sun

Two Signs of the Kingdom

It has been reported that someone entered the entire text of the four Gospels into a computer, and then asked the computer the question: "Why did Jesus come to earth?"

The computer, not having a doctrine or a theology, could only answer on the basis of input.

It answered: "To establish a kingdom."

For the computer it is of necessity on the basis of input. But for us, who are capable of reason, we can arrive at the same conclusion on the basis of evidence.

Jesus continually spoke about the Kingdom. Most of His parables were illustrations of different aspects of the Kingdom. His miracles were all about the Kingdom, and its life-giving purpose.

From Jesus' teachings, His parables, and His miracles, we learn that the Kingdom has two aspects. One aspect of that Kingdom is heavenly, and one aspect is earthly. It is a Kingdom that is heavenly in that its rulership is from heaven. But it is a Kingdom that is earthly, because it will involve a new government on earth – and the seat of that government will be Jerusalem.

As we saw in the preceding chapter, that govern-

ment that will begin in Jerusalem will grow, just like the Golden Spiral, until it fills the whole earth.

“But it shall come to pass in the end of the days, the mountain of the house of Jehovah shall be established on the top of the mountains, and it shall be lifted up from the hills; and peoples shall flow on it. And many nations shall come and say, ‘Come, and let us go up to the mountain of Jehovah and to the house of the God of Jacob. And He will teach us from His ways, and we will walk in His paths.’ For the law shall go forth out of Zion, and the word of Jehovah from Jerusalem.”
(Micah 4:1-3)

Notice the time setting for this prophecy. It is “*in the end of the days.*” What days? Probably the days of man’s 6,000-year rulership. When that allotted time span comes to an end, then the Kingdom of God can be established in the earth, with Jesus as the King who sits on David’s throne.

However, when Jesus was here, at His first advent, He talked about the Kingdom so much that His disciples thought He was going to set it up then. It was at a time in Israel’s history when they were under Roman rule, and they desired to be an independent kingdom again, just like in the days of David.

But when He hung on the cross, dying, they felt that their hopes had been dashed. The Kingdom had

not become a reality. They were confused and bewildered.

The last day that Jesus was with them, as they walked toward the Mount of Olives, they asked Him, *“Will you at this time restore the kingdom to Israel?”* They were thinking of the restoration of the Davidic kingdom. But what Jesus had in mind in all of His illustrations of the Kingdom was the antitypical Kingdom of David, under the rulership of King Messiah.

During His brief ministry, Jesus had given His disciples many signs of the Kingdom. But His first two were especially tailor-made to portray the heavenly aspect of the Kingdom and the earthly aspect of the Kingdom. It appears that He was teaching us that these two events would be the first two major events of His return. These two signs were recorded by John. He called them: *“beginning of the signs,”* and *“the second sign.”*

The Greek word *σημειον*, which John used, is sometimes translated *“miracle”* and sometimes *“sign.”* It has the meaning of an *“indication”* – something that has a message of some future event.

Both of these signs were given in Cana of Galilee.

The first one is recorded in John 2:1-11:

“And the third day there was a marriage in Cana of Galilee; and the mother of Jesus was there: and both Jesus was called, and his dis-

ciples, to the marriage. And when they wanted wine, the mother of Jesus saith unto him, 'They have no wine.' Jesus saith unto her, 'Woman, what have I to do with thee? Mine hour is not yet come.' His mother saith unto the servants, 'Whatsoever he saith unto you, do it.'

And there were six waterpots of stone, after the manner of the purifying of the Jews, containing two or three firkins apiece. Jesus saith unto them, 'Fill the waterpots with water.' And they filled them up to the brim. And he saith unto them, 'Draw out now, and bear unto the governor of the feast.' And they bare it.

When the ruler of the feast had tasted the water that was made wine, and knew not whence it was: (but the servants which drew the water knew;) the governor of the feast called the bridegroom and saith unto him, 'Every man at the beginning doth set forth good wine; and when men have well drunk, then that which is worse. But thou hast kept the good wine until now.'

This beginning of signs did Jesus in Cana of Galilee, and manifested forth his glory; and his disciples believed on him."

It was exciting to find that the mention of the "third day" in this text uses the Greek words *ημερα τριτη*, which multiply to 1152. The name *Kingdom of*

God also has a numeric value of 1152. It is 2×576 . That the number indicating the Hebrew year 5760 is found here is also exciting, for it suggests the nearness of the fulfillment of the sign.

Notice that both Jesus and His disciples were called to the marriage. It brings to mind the beautiful prophecy in Revelation 19:9:

“Blessed are they which are called unto the marriage supper of the Lamb.”

It has taken two thousand years to select and prepare the Bride, and during that time, Jesus, the bridegroom, has been preparing a place for them in the Father’s house.

“In my Father’s house are many mansions (rooms) ... I go to prepare a place for you. And if I go and prepare a place for you, I will come again, and receive you unto myself; that where I am, there ye may be also.” (John 14:2-3)

Since this was specifically mentioned as the “*first sign*,” it appears to suggest that the coming for the Bride, and taking her to His Father’s house, where the wedding takes place, is first on the agenda. We do not know the specific time for this event, but it apparently follows closely after the transfer of the right of rulership.

Jesus had the servants fill six waterpots to the brim with water. Then He turned the water into wine.

This possibly pictures the filling to the fulness the six thousand years of man's experiences, and His transforming it into the wine of the Kingdom. The specific statement that these waterpots were filled "*to the brim*" indicates that the six thousand years would be fully complete before the serving of the wine could take place.

"And Jehovah of hosts shall make for all people a feast of fat things in this mountain; a feast of wine on the lees, of fat things full of marrow, of wine on the lees well refined. And He will destroy in this mountain the face of the covering which covers all people, and the veil that is woven over all nations. He will swallow up death in victory! And the Lord Jehovah will wipe away tears from all faces."
(Isaiah 25:9-10)

However, in the "*sign*" that Jesus gave at this marriage, He was not only illustrating man's six thousand years, followed by the wine of the Kingdom, but He is also illustrating the specific development of those who would dispense the wine – the Bride.

Thus, in this story we have the six waterpots – 6 being the number that pertains to man. The Bride was selected from mankind. The stone waterpots picture the earthly nature of the ones called to be the Bride. The water put into the earthen pots represents the life right that Jesus gave to His beloved. And the

turning of it into wine represents the change of nature – from earthly to heavenly. It is these who will dispense the “*wine*” of life to all the world in that Kingdom which He will set up in Jerusalem, which will flow out to all who desire to receive it.

“And the Spirit and the Bride say ‘Come.’ And let him that is athirst come. And whosoever will, let him take the water of life freely.” (Revelation 22:17)

The first sign was given on the “*third day*.” The second sign is also on a third day, for it specifically states that it was “*after two days*.” And, as was shown previously, the Hebrew words “third day” multiply to 5760. That year is apparently the pivotal year, which ends the long period of 6,000 years, and begins the new era which will soon usher in a righteous government for man – the Kingdom of Jesus Christ.

Let’s read the second sign:

“Now after two days he departed thence, and went into Galilee.... So Jesus came again into Cana of Galilee, where he made the water wine. And there was a certain nobleman, whose son was sick at Capernaum. When he heard that Jesus was come out of Judea into Galilee, he went unto him, and besought him that he would come down, and heal his son: for he was at the point of death Jesus saith

unto him, 'Go thy way; thy son liveth.' And the man believed the word that Jesus had spoken unto him, and he went his way. And as he was now going down, his servants met him, and told him saying, 'Thy son liveth.' Then enquired he of them the hour when he began to amend. And they said unto him, 'Yesterday at the seventh hour the fever left him.' So the father knew that it was at the same hour, in the which Jesus said unto him, 'Thy son liveth'; and himself believed, and his whole house. This is again the second sign that Jesus did, when he was come out of Judea into Galilee." (John 4:43-54)

Notice the time setting. It was after two days, thus on the third day. Yet, the hour in which the son of the nobleman was healed was the seventh hour. It may be suggesting that this pictures something that will happen on the seventh day, following the ending of the six "days" of man's rule. The seventh day of man's rule is concurrent with the third day from the first advent of Jesus.

The first sign had been in Cana of Galilee, but this second sign had been the healing of a man from Capernaum of Judea. It shows the difference between the heavenly nature of the first sign, and the earthly nature of the second sign.

Capernaum means "consolation." It reminds us

of the man named Simeon who was in the Temple when they brought the baby Jesus in for His ritual dedication. It was said of Simeon that *“he looked for the consolation of Israel.”* He was looking for the Kingdom to be restored to Israel. Thus Capernaum, the city of “consolation” is used in this second sign to represent the nation of Israel. And her consolation will come with her healing.

It was the son of a nobleman (royal official) who was sick unto death at Capernaum. Thus it aptly represents the nation of Israel, for they had been given status as the specially chosen people of God. But as a nation they became ill – they were sick unto death. And had it not been for the promised healing, through the Lord Jesus Christ, they would have died.

“In that day I will raise up the tabernacle of David (house of David, which will belong to Jesus) that has fallen, and will wall up its breaks. And I will raise up its ruins, and I will build it as the days of old, so that they may possess the remnant of Edom and all the nations on whom My name is called, states Jehovah who is doing this. Behold the days are coming, states Jehovah, that the plowman shall overtake the reaper, and the treader of grapes him who sows seed. And the mountains shall drop sweet wine...and I will plant them on their land, and they shall no more be pulled

*up out of their land which I have given to them,
says Jehovah your God. (Amos 9:11-15)*

When the plowman will overtake the reaper it will be the fulfilling of the promise that God gave to Israel in Leviticus 26, if they would obey Him then:

“Your threshing will last for you until grape gathering, and grape gathering will last until sowing time – you will thus eat your food to the full and live securely in the land.”

We are not told specifically the dates that these two signs will be fulfilled, however, since these were called the “*beginning of signs*” and the “*second sign*” the inference is that they are the first two items of importance on the agenda when the right to rule is transferred from man to Him who purchased it with His own precious blood.

The Unpronounceable Name

The name of God is a sacred name. For the Israelite it is not to be spoken. The Hebrew spelling of the name that Christians call Jehovah is יהוה, which is equivalent to the English letters YHVH. There is no J in the Hebrew alphabet. A more accurate pronunciation of the four letters would be Yahweh. However even this is not acceptable to some, who feel that the name should not be spoken. Many today, when writing the name God, will spell it G-d, leaving out the vowel so it cannot be pronounced.

Sometimes the four letters – יהוה – are called the Tetragrammaton. It is a Greek term, meaning four-lettered.

Throughout this book, in quotations from the Old Testament, I have used the name Jehovah. This is because the quotations are from the *J. P. Green Interlinear Bible*, which uses this spelling for the sacred name.

In the Bible there are several words used to convey the sacred name, each with a slightly different meaning, but each with numeric value that is important and consistent with the number patterns. The name יהוה, which is used in this book as Jehovah,

has a numeric value of 26. It is a number that has been planted in our earth in a most magnificent way.

Jehovah

יהוה

5 6 5 10

26

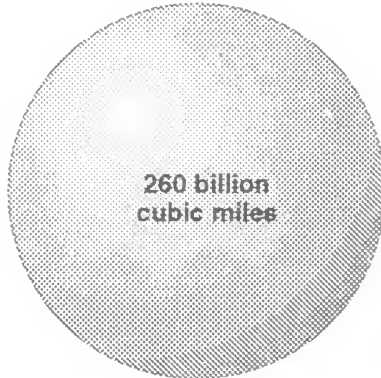

$$\frac{1}{6} \pi D^3$$

$$D = 7,920 \text{ miles}$$

Volume of the smooth sphere of the earth is
260,000,000,000 cubic miles

That sacred name is not only planted in our earth, it is represented by the entire volume of the earth. I find this fantastic! I have been studying the Gematria of the Bible for half a lifetime, but it was only today that I became aware of this magnificent reality!

On page 25 of this book is shown the reality that the square area of the entire surface of the smooth sphere of earth is 197 million square miles. And the name Immanuel has a numeric value of 197. It is exciting indeed to find that both the Father and the Son have placed their names here, in man's home. But there's more!

When we multiply the letter-numbers in this sacred name, it produces 1500. Throughout the New Testament the Greek word for light is $\phi\omega\varsigma$, which has a numeric value of 1500.

By using the *Klala* method of Gematria, which adds the squares of the number values of the letters, this sacred name becomes 186. ($10^2+5^2+6^2+5^2 = 186$)

The speed of light is generally stated as 186,000 miles per second. Thus the sacred name is inseparably linked to light.

There is yet another method of Gematria. It is called *Atbash*. It is more complicated. It is a method of encoding that substitutes the last letter of the alphabet for the first, and so on down through the complete alphabet. Jeremiah used this method of encoding when prophesying about the king of Babylon. (Jer. 25:26 and 51:41) He called him Sheshack. He had taken the name Babylon, which is spelled בבל, and by this method of letter substitution, obtained ששק, which is Sheshack.

I reasoned that if Jeremiah could do it, then I would give it a try with the sacred name.

By the *Atbash* method of Gematria, the name of Jehovah would be spelled $\gamma\delta\zeta\eta$. By multiplying the numeric values of these letters, we find it produces 25920. It is the number of years that is required for the sun to pass through all 12 signs of the Zodiac, or what is generally called the Great Year. By this method the sacred name is still associated with light.

In the New Testament the name of God is spelled several ways, depending upon its placement in the sentence. One of these ways of spelling is $\Theta\epsilon\omega\nu$, whose numeric value is 864. It is still connected to the concept of light.

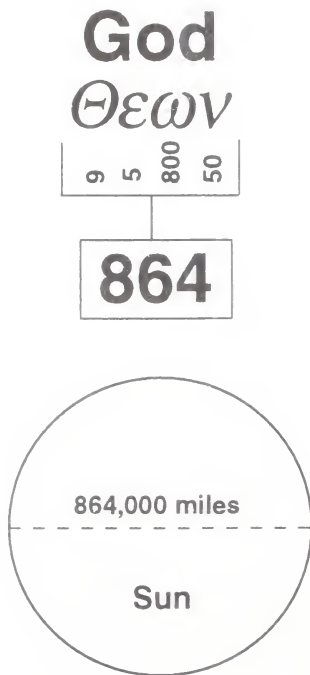

Diameter of the sun = 864,000 miles

It is interesting to note that the number 864, which represents the diameter of the sun, is also one of the ways of spelling God in the Greek text of the New Testament. Upon realizing this, it immediately brought to mind a text I had memorized as a small child.

“For God so loved the world that he gave his only begotten son, that whosoever believeth in him should not perish, but have everlasting life.” (John 3:16)

How beautifully the light from the sun, which bathes the earth in its life-giving warmth every twenty four hours, pictures His love which caused Him to give His only-begotten Son, Jesus Christ, that we might have salvation. That 93 million miles which the light of the sun travels to our earth, pictures His love, which also bears the number 93 (Love, *αγαπη* = 93). And just as in the illustration below, we are surrounded by the life-giving benefits of the sacrifice of the Lord Jesus Christ, bringing salvation to man.

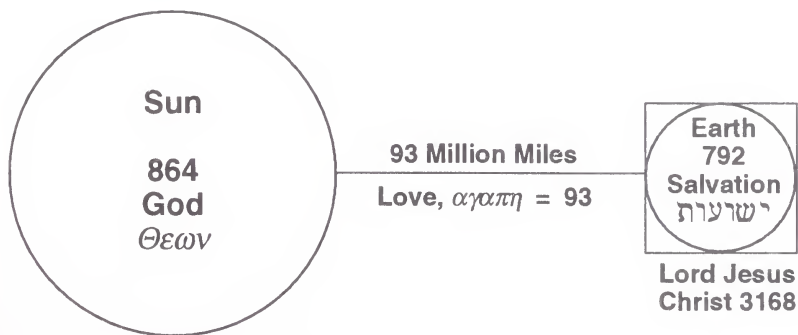

Considering the speed at which light travels from the sun to our earth as the rounded number 186,000 miles per second, I tried dividing this figure by the number that represents the earth and man – the number 6. Surprisingly it produces another number that represents God.

$$186,000 \div 6 = 31,000$$
$$31 = \text{God, (El, אֱלֹהִים)}$$

Moses, when speaking of the time before creation began, said “*From everlasting to everlasting You are God.*” He used the word אֱלֹהִים, whose number is 31. His use of the word “*everlasting*” here is מְעַלְמַלְמֵם, which has a numeric value of 186.

I stand in awe of Him, and of His numbers.

The Pattern

When I began the study of Gematria, many years ago, I really did not know what to look for. One number meant no more to me than another. I had no idea what numbers were significant and what numbers were simply there at random. It is like looking at pebbles in a stream, and admiring their smooth shapes and bright colors, and then becoming aware that someone has collected some of those stones and constructed beautiful castles with them. Suddenly we realize that those stones are no longer random – they have been arranged in patterns that form a beautiful edifice.

Not knowing which numbers were an intended part of the Code, and which numbers were random, I began recording them into notebooks, in numerical order. It seemed logical that if patterns existed, they would eventually make themselves apparent.

As my notebooks grew in fullness and in quantity, the patterns did indeed become apparent. But I was not prepared for their exquisite beauty or their global and even astronomical implications. The significant numbers in the Gematria of the Bible had to do with the subject of salvation through Jesus Christ; and those same numbers were the numbers in the

geometry of our solar system, particularly the relationships of the earth, sun and moon.

There was no denying it! The numbers repeated the design over and over again, from Genesis to Revelation. It was the story of salvation.

And shouting at me from every page was the obvious message, "The Author of creation is also the Author of salvation."

The ancient mathematician and mystic, Pythagoras taught that nature is commanded by numbers. We could identify that more precisely by saying that Creation is commanded by numbers, and the Creator is the personification of those numbers. Of all his discoveries and philosophies, one enduring theorem has come down to us, and is a fundamental principle of mathematics today. It is his concept of the right triangle. To Pythagoras, the right triangle was the crossing of gravity with the horizon. When he had proven his great theorem, he offered a hundred oxen to the Muses in thanksgiving. What he experienced is such as every scientist or physicist feels when the numbers say, "This is the key to the structure of nature."

Pythagoras left for us the truth that the square on the hypotenuse of a triangle is equal to the squares of its two sides if, and only if, the angle they contain is a right angle. The simplest form of the right triangle is the 3:4:5 triangle, which is found to be in complete harmony with nature and the universe.

Pythagoras had found a great truth, but the application of it had been planted in the universe from the beginning of creation.

If a model of the moon were placed tangent to a model of the earth, and squares drawn on the diameters of their circles, the model would look like this.

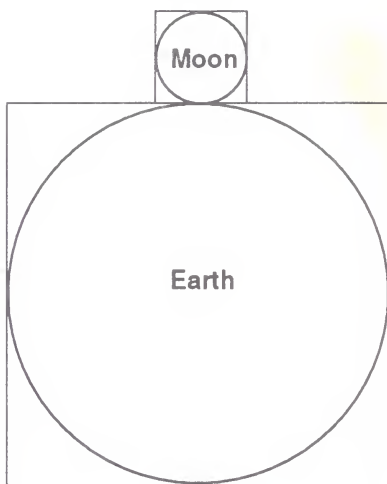

Next, connect the two squares as shown below.

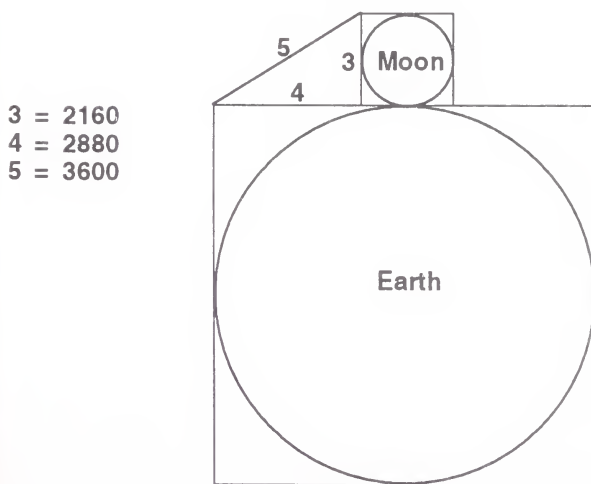

This most majestic of all right triangles bears numbers that are equally majestic, for they have to do with the Kingdom that will fill the earth.

2160 = All nations shall serve Him, נֹרִים יַעֲבֹדוּהוּ, כל, (Psalm 72:11)

2160 = All the nations, כָּל הַגּוֹיִם, (Isa. 14:26) (by multiplication)

2160 = The face of all the earth, פְּנֵי כָל הָאָרֶץ, (Gen. 1:28) (by multiplication)

2160 = All nations, πάντα ἔθνη, (Rev. 12:5) (by multiplication)

2160 = New earth, הָאָרֶץ הַחֲדָשָׁה, (Isa. 66:22) (by multiplication)

2160 = His dominion, מַשְׁלוֹ, (Zech. 9:10) (by multiplication)

2160 = Thousand years, χίλια ἔτη, (Rev. 20:5) (by multiplication)

2880 = Kingdom of heaven, βασιλεια των ουρανων, (Matthew 13:47)

2880 = A blessing in the midst of the earth, הָאָרֶץ בְּרִכָּה בְּקִרְבָּהּ, (Isa. 19:24) (by multiplication)

2880 = Redemption, λυτρωσιν, (Heb. 9:12) (by multiplication)

3600 = The Lamb's book of life, τω βιβλιω ζωης αρνιου, (Rev. 21:27)

3600 = The Lord reigns, יַהֲרֹה מֶלֶךְ, (Psa. 93:1) (by multiplication)

3600 = The Kingdom, την βασιλειαν, (Luke 12:32) (by multiplication)

This pattern in the design of earth and moon is another confirmation of the surety of the Kingdom. It was part of God's plan from the beginning, before the creation of the earth and the moon. It further attests to the assurance found in Psalm 89:34-37:

"I will not violate my covenant or alter what my lips have uttered. Once for all, I have sworn by my holiness – and I will not lie to David – that his line will continue forever and his throne endure before me like the sun; it will be established forever like the moon, the faithful witness in the sky." (NIV)

If we draw a square around the figure of earth and moon, one side of the square would measure 10,080 miles, and the perimeter of the square would measure 40,320 miles. The numbers are magnificent!

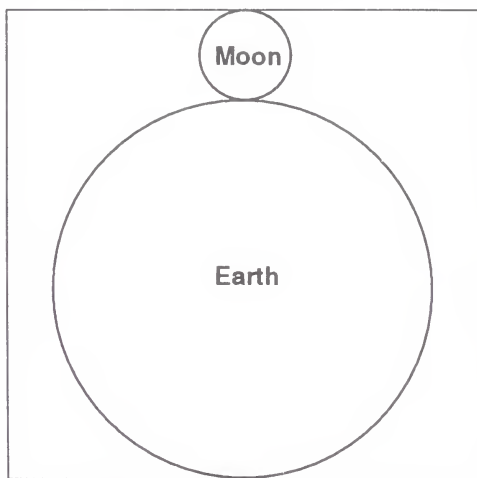

One side of square = 10,080 miles
Perimeter of square = 40,320 miles

The combined diameters of earth and moon add to 10,080 miles. My Periodic Table of the Elements, that hangs on the wall above my computer is nearly shouting at me: "The atomic weight for the hydrogen atom is 1.0080."

Hydrogen is Number 1. It represents the *real* Number One – the Author of Creation. Its atomic weight is one of the magnificent numbers in God's pattern of His works and His word.

1008 = The work of thy fingers, *מעשה אצבעתיך*, (Psalm 8:3)

1008 = When the Lord of hosts shall reign in Mount Zion, *כי מלך יהוה צבאות בהר ציון*, (Isa. 24:23)

1008 = The Lord is high above all nations, and His glory above the heavens, *על השמים כבודו, רם על כל גוים יהוה*, (Psalm 113:4)

10080 = He shall be great, and shall be called the Son of the Highest, and the Lord God shall give Him the throne of David, *ουτος εσται μεγας και υιος υψιστου κληθησεται και δωσει αυτω κυριος ο Θεος τον θρονον Δαυιδ*, (Luke 1:32)

The perimeter of the square which encompasses both the earth and the moon tells the story of creation, of man, of redemption, of the Kingdom, of everlasting life, and of the Almighty God Himself. It is as

if the numbers are the chapter headings in the book of the story of creation.

- 40320 = Almighty, *παντοκρατωρ*, (Rev. 1:18) (by multiplication)
- 40320 = His work, *פִּעֲלָתוֹ*, (by multiplication)
- 40320 = Man, *ανθρωποις*, (by multiplication)
- 40320 = the Last Adam, *εσχατος Αδαμ*, (I Cor. 15:45) (by multiplication)
- 40320 = Kingdom of heaven, *βασιλεια των ουρανων*, (Matthew 13:47) (by multiplication)
- 40320 = Everlasting life, *חיי עולם*, (Daniel 12:2) (by multiplication)

It gets even more exciting when we put the moon into orbit around the earth. Suddenly the numbers relate to the size of the entire universe, and the work of creation.

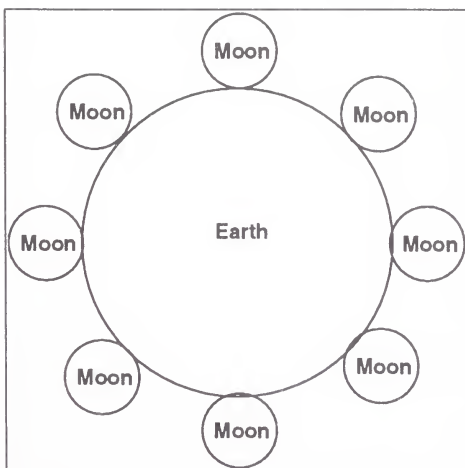

12,240 = One side of square

1224 = God's creation
κασις Θεου

According to the most recent calculations by astro-phycisists, the size of the universe is approximately 30 billion light-years across. Most of us cannot think in these terms. A light-year is distance, not time. One light year is about 5,878,486,800,00 miles. This would suggest that the size of the universe in miles would be about 176,354,604 with fifteen zeros after it. Dropping the zeros brings it a little closer to our comprehension range. In fact, for the sake of our computation, let's put a decimal in it, thus it would be 176,354.604.

Throughout the Gematria of the Bible, the number 144 is used to denote that which is in God's realm. The Hebrew word *kedem*, קדם, which is translated beginning, origin, eternal, everlasting, has a numeric value of 144. When we think of God as having no beginning nor ending – “*from everlasting to everlasting*” – we must think in terms of a circle, which has no beginning nor ending. The Hebrew word for circle is חרף, which multiplies to 144.

Let's divide the number of light-years in the size of the universe by the number 144 – God's realm.

$$176,354.604 \div 144 = 1224.6847$$

Since the 30 billion light years was an approximate figure, perhaps we can work the equation backward from the known figure of 1224, which is the Gematria for “*God's creation.*”

$$1224 \times 144 = 176,256$$

Doing this would render the size of the universe 176,256 with eighteen zeros after it, in miles. Divide this by the length of one light-year and it gives the more precise size of the universe as being 29.9832 billion light-years across.

This produces a figure that is certainly very close to the astro-phycisist's suggestion of "about" 30 billion light-years. When dealing with numbers this large, the difference between 30 and 29.9832 is negligible.

Returning to the earth-moon diagram, we find more features that have a direct relationship to the Gematria of the Bible, suggesting that both share a common Author.

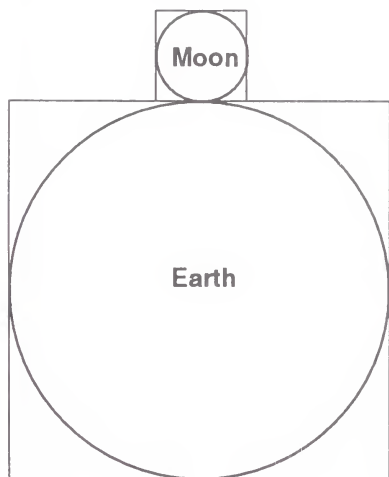

- 7920 = Diameter of earth
- 3960 = Radius of earth
- 2160 = Diameter of moon
- 1080 = Radius of moon
- 5040 = Combined radii of earth and moon
- 8640 = Perimeter of square drawn on moon
- 31680 = Perimeter of square drawn on earth
- 10080 = Combined diameters of earth and moon

Notice that the sum of the digits in each of the above numbers is 9. It is the number that denotes

completion and finality – or the wholeness of a thing or concept. It appears to be saying the same thing as is found in Genesis 1:31 at the completion of the work of creation:

“And God saw everything that He had made; and, behold, it was very good!”

We’ve already seen the remarkable relationship of some of these numbers in the above diagram: 7920 and 3960 are both the Gematria for “*salvation*”; 3168 for Lord Jesus Christ; 10080 for the work of creation; 864 for God; 2160 for the Kingdom that will engulf the whole earth; 5040 the coming of Shiloh and the transfer of the right of dominion at the beginning of the seventh day – but now we find one additional number in this diagram that completes the story.

1080 miles, Radius of moon

1080 = The Holy Spirit, *πνευμα το αγιον*, (Acts 1:16)

In chapter 3 it was shown that the place where atonement was made, Calvary, bears a relationship to its other name, Golgotha, and the One who made atonement there, Jesus Christ, by the beautiful Golden Proportion. But it was a very special display of this magnificent proportion. It was drawn on the radii of earth and moon.

I show this diagram again, because it is only the first step to a relationship with the size of the earth

and moon that has far reaching implications. It involves the ancient structure built in the land of Egypt, which is considered one of the seven ancient wonders of the world, and the only one still in existence – the Great Pyramid.

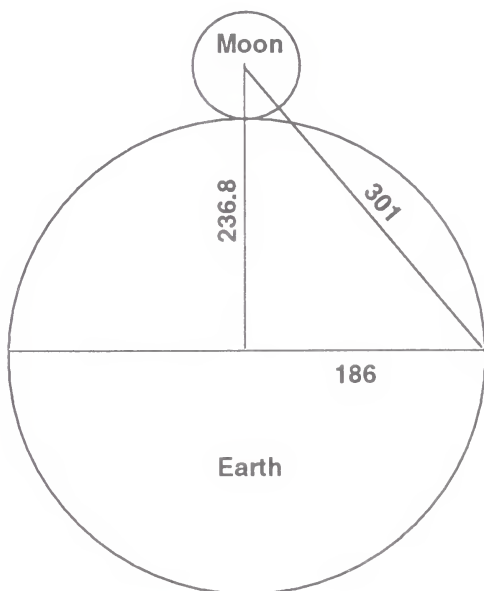

301 = Calvary
 186 = Golgotha
 236.8 = Jesus Christ

In the above diagram, I have shown the right triangle that is drawn on the radii of earth and moon. If we drew another one just like it on the other half of the circles, the two right triangles would form a larger triangle that would have exactly the same proportions as the Great Pyramid, having a base angle of $51^{\circ} 51'$. It might be thought a coincidence if it were not for the

many other similar relationships that the Great Pyramid bears to the earth, sun and moon. Many volumes have been written about these magnificent relationships, but for our purposes here, I will confine it to one which I feel is awesome.

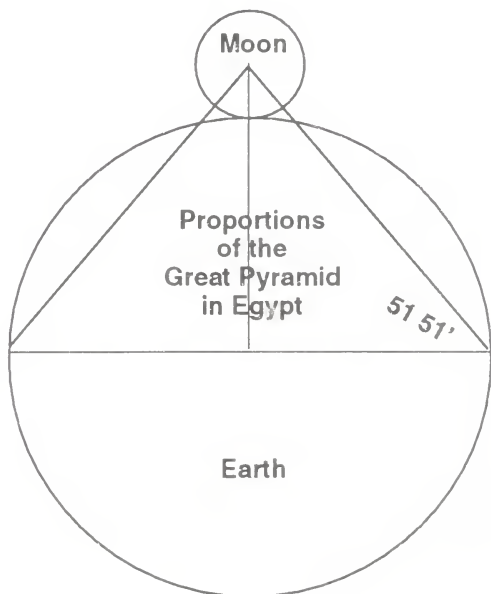

The Great Pyramid has been encoded into the Bible. The decoding of this amazing cryptogram was first done by O. deBlaere, of Antwerp, Belgium several generations before I became aware of the existence of the Number Code. It is found in Isaiah 19:19-20, which reads:

“In that day there shall be an altar to Jehovah in the midst of the land of Egypt, and a pillar to Jehovah at its border. And it shall be

for a sign and a witness to Jehovah of hosts in the land of Egypt.”

By assigning the number values to each Hebrew letter used in these two verses, we find their total value is 5449. But long before the Gematria of this text was discovered, it was known that the height of the Great Pyramid, from its socket level base to its summit platform, is 5449 Pyramid inches. It is not a coincidence. It bears the marks of a Master Architect. Perhaps the builder even left His signature there.

If we were to use this figure, 5449, and drop the unit identification, and divide it by the Egyptian Royal Cubit, which was 1.72 feet. (We can do this because we are not using units, we are using numbers.) The answer would reveal something very exciting about this awesome structure. It bears the name of the Lord Jesus Christ.

$5449 \div 1.72 = 3168$ $3168 = \text{Lord Jesus Christ}$

The very text that describes the location of the Great Pyramid, also identifies it by the measure of its height.

And what a description of location! It sounds self contradictory. But when examined more carefully, we find that the only spot on earth answering to that description is the spot where the Great Pyramid sits.

It was in the year 1868 that the Chief Hydrographer of the United States Coastal Survey, Henry Mitchell, took special notice of the remarkable shape of the Nile Delta. He observed that the regularity of the general curvature of the coast of the delta forms a quadrant. This led him to wonder what point marked the focal point of the quadrant, and thus the center of the circle. To his amazement, he found the Great Pyramid sitting on the precise spot. With this discovery, he exclaimed: "That monument stands in a more important physical situation than any other building erected by man." And indeed it does.

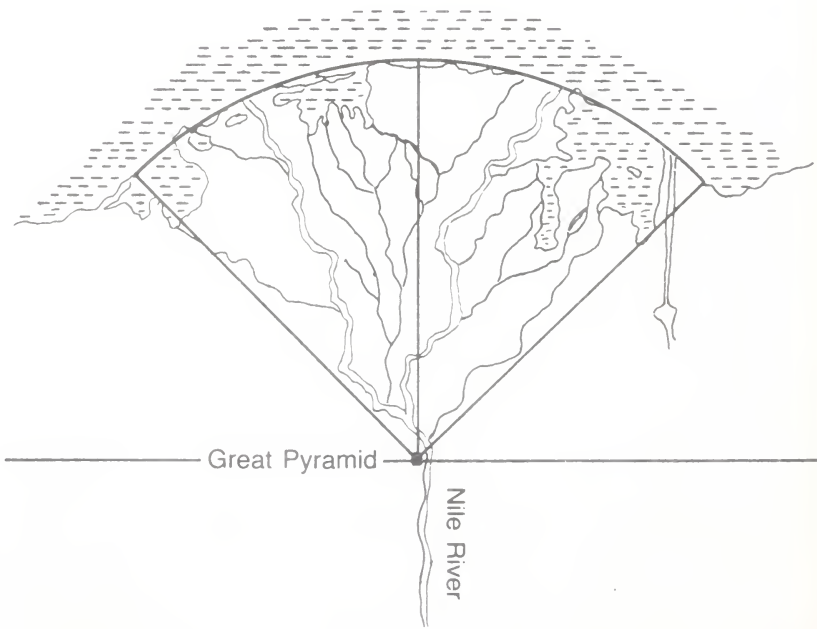

And if we measured the sides of the quadrant (which would be the radius of the circle), it would be 108 miles. I found this exciting because it would mean the diameter of the circle would be 216 miles.

We just observed that the diameter of the moon is 2,160 miles, and that the number 2160 has a definite relationship to the Gematria of the Bible, pointing especially to the Kingdom of Jesus Christ and its world-wide rulership. Now we find His name planted in the height of this Great Pyramid that sits majestically at the center of a circle measuring 216 miles in diameter. Wait, while I catch my breath! Can this be real?

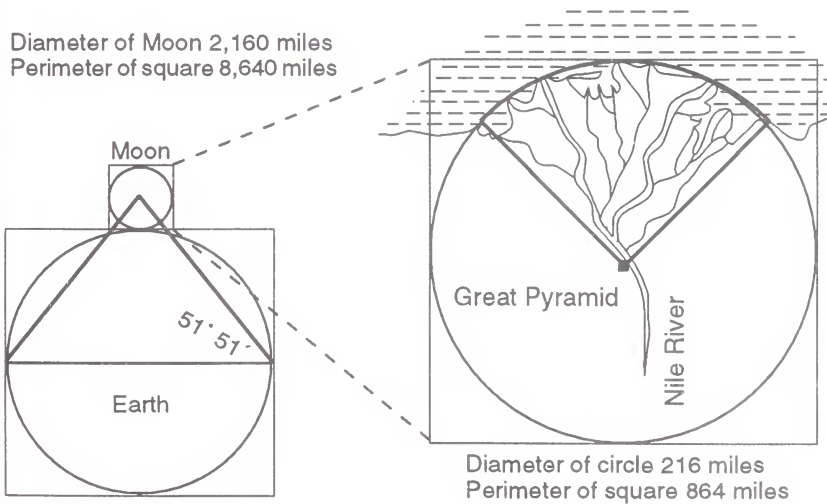

Ponder it for a moment. Is it a colossal coincidence, or the careful planning of a Master Designer? Even the supposed geographical and astronomical

knowledge of the ancients could not have accomplished this one, for they could not control nor devise the shape and size of the Nile Delta. That required a Designer greater than man.

The Great Pyramid is at the center of the circle. In fact, if the topstone, which was never lifted into place, were indeed on the Pyramid, it would be precisely at the center of the 216 mile diameter. Jesus referred to that missing stone, and used it as a symbol of Himself. He called it, "*The stone which the builders rejected,*" (Matthew 21:42). In the Greek text of the New Testament, it is written: *λιθον ον απεδοκιμασαν οι οικοδομουντες*, which has a numeric value of 2160. The identification of the stone with its geographical location is amazing! It is evidence of a design far beyond the scope of man's expertise.

Seeing, then, that the Gematria of the Bible is so intricately interwoven into the fabric of creation – especially the creation of the earth, sun and moon – this is where we might reasonably expect to find the pattern for the basis of the numbers. The study of Gematria has shown that the numbers do indeed display an intended pattern. Does this same pattern exist in the geometry of the earth, sun and moon?

I was impressed by the use of the 3:4:5 triangle in the size relationship of earth and moon. Again I was impressed by the use of the 3:4:5 triangle drawn on the radius of earth, producing the number 3168, Lord Jesus Christ. I will show these two diagrams

again, because I feel they are a fundamental law of mathematics, and also a fundamental part of the pattern of creation.

3 = 2160
 4 = 2880
 5 = 3600

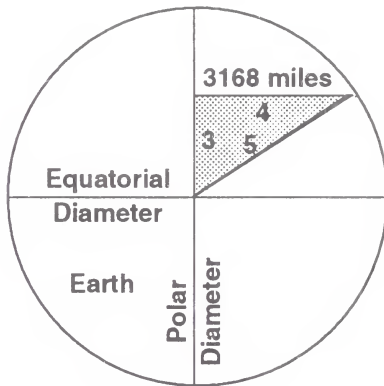
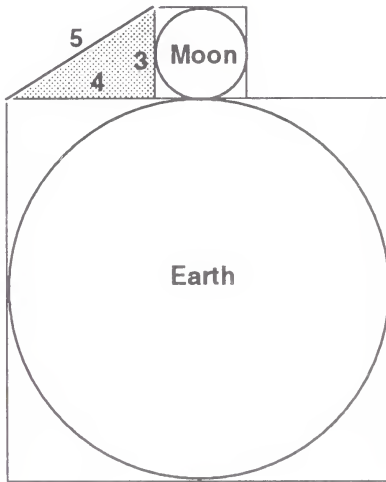

Thus the 3:4:5 triangle is found in the relationship of earth, its moon, and the name Lord Jesus Christ. But, seeing the 3:4:5 triangle within the circle of the earth, led me to wonder. What would be revealed if we placed the earth *within* a 3:4:5 triangle?

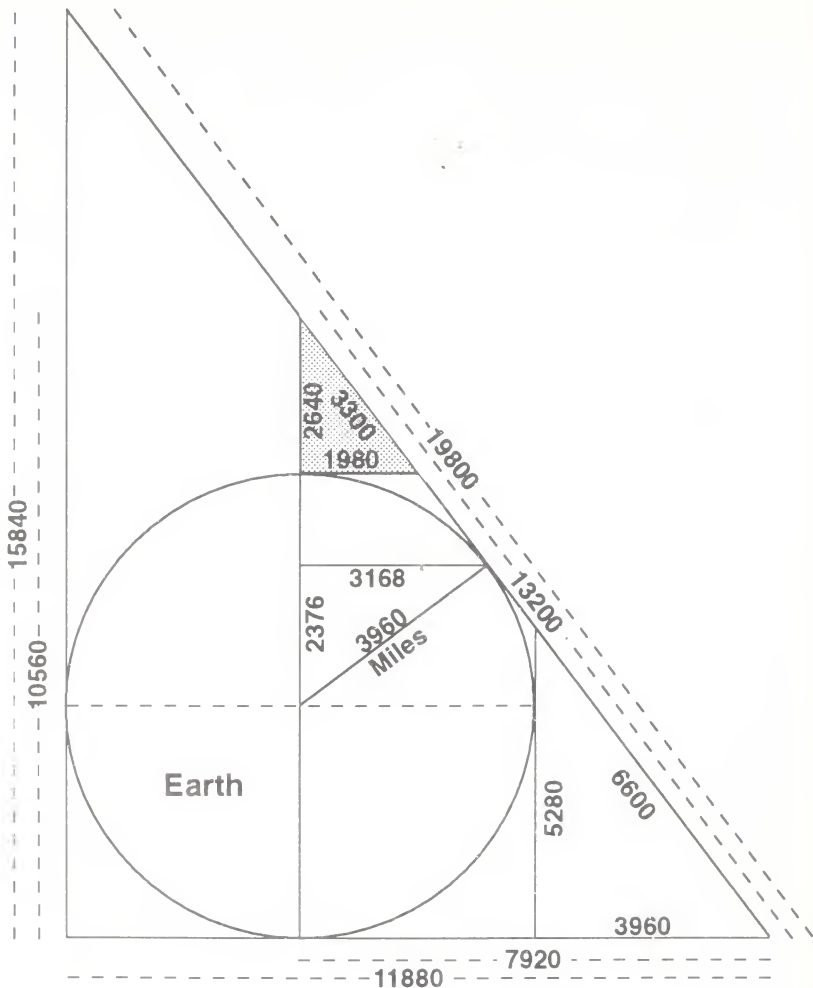

The first thing noticeable was the number of subsequent 3:4:5 triangles that could be drawn on its geometry. Measuring these additional triangles, I was amazed at the regularity with which the sacred numbers of the Bible occurred. They were numbers which I had already recorded in my bulging notebooks.

On the triangle that is highlighted we find the three numbers, 2640, 3300 and 1980. They are numbers which are descriptive of Jesus.

- 264 = Truth, *αληθειας*, (Jesus is the personification of Truth.)
- 2640 = The Light, *του φωτος*, (Jesus was the true light.)
- 2640 = In the likeness of sinful flesh, *εν ομοιωματι σαρκος αμαρτιας*, (Romans 8:3) (Jesus took the nature of Adam that He might take his place in death.)
- 2640 = The coming of the Lord, *η παρουσια του κυριου*, (James 5:8)
- 330 = Holy and just One (Jesus), *αγιον και δικαιον*, (Acts 3:14)
- 330 = To make atonement, *לכפר*, (Lev. 16:17) (Jesus made atonement for the sin of Adam when He was 33 years old.)
- 198 = The King in His beauty, *מלך בייפיו*, (Isaiah 33:17) (Jesus as the King on David's throne.)
- 198 = He is altogether lovely, *כלו מחמרים*, (Sol. 5:16) (Prophetic of Jesus.)
- 19.8 inches = The cubit used in the building of Solomon's Temple, the meeting place between God and man.

The next 3:4:5 triangle is drawn on the radius of earth, and it bears the name of the Lord Jesus Christ.

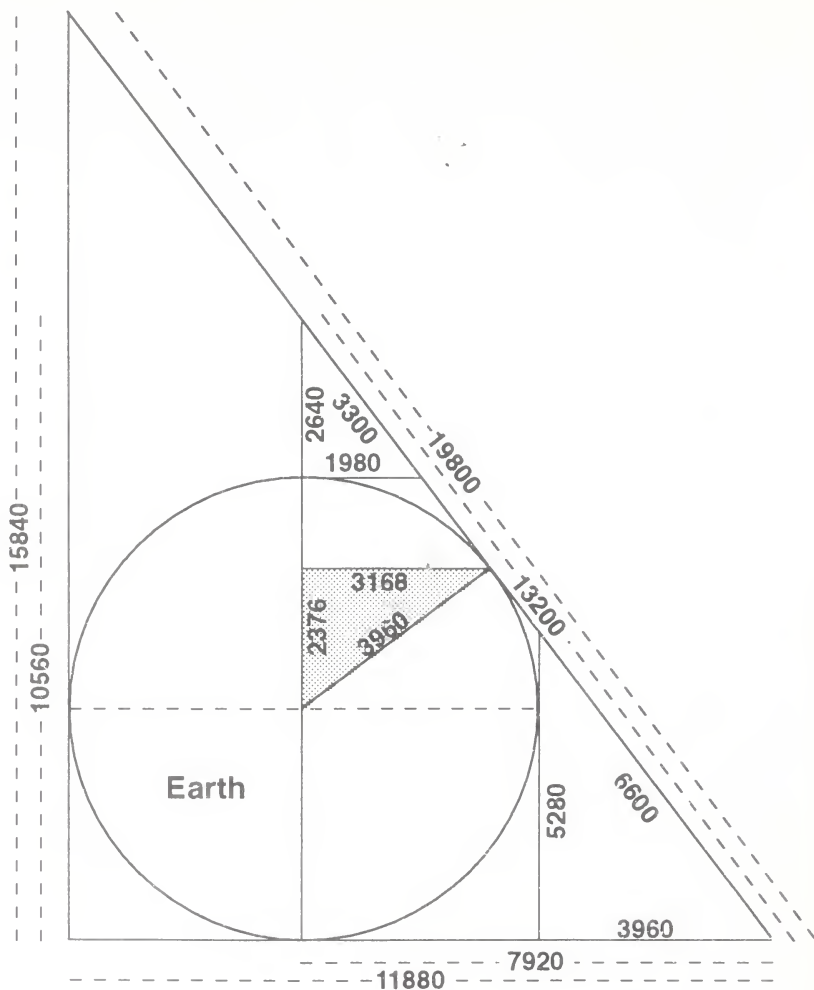

When Pythagoras discovered the beauty of the 3:4:5 triangle, I'm sure he had no idea that it was the signature of the Lord Jesus Christ, planted in the radius of our earth. Yet it is there, for all to see – a glorious witness that cannot be eradicated. It is there to stay, forever!

The hypotenuse of this right triangle is the

radius of the earth, which is 3,960 miles. What a beautiful demonstration of the work of salvation! That is the purpose for which Jesus came to this earth.

3168 = Lord Jesus Christ, *Κυριος Ιησους Χριστος*

3168 = Mediator between God and man, *μεσιτης Θεου και ανθρωπων*, (I Timothy 2:5) (Jesus is the Mediator, to bring the reconciliation between God and man. He did it at the cost of His life.)

31,680 miles = perimeter of a square drawn around the earth.

396 = Salvation, *הישרעה*, (Isaiah 12:3)

396 = A highway and a way, *מסלול ודרך*, (Isaiah 35:8) (Jesus is the way to life.)

396 = Purification, *מרוקים*, (Through the cleansing blood of Jesus, man can be purified from the effects of Adamic sin.)

3,960 miles = Radius of earth

The third number in this 3:4:5 triangle is 2376. For many years I searched for this number in the Hebrew and Greek texts. I knew it was part of the number pattern, but could find no evidence of it in the Gematria of the Bible. This was frustrating, because the number kept showing itself in the patterns, but I could not identify it.

Then one day, while working in Genesis 49, it nearly jumped off the page at me. In this chapter, the dying Jacob is bestowing a “blessing” on each of his

twelve sons. We call them “blessings” but in reality most of them were anything but blessings – and especially so with Jacob’s words to Dan.

But first, let’s notice what Jacob said to his sons before he singled out each one and blessed them.

“And Jacob called unto his sons, and said, ‘Gather yourselves together, that I may tell you that which shall befall you in the last days.’”
(Gen. 49:1 KJV)

The “*last days*” were a long way down through the stream of time from Jacob’s day. We are the generation living in the “*last days*.” This is significant when we attempt to interpret the message that Jacob gave to each of his sons. And thus with his words to Dan we find a startling reality today.

“Let Dan be a serpent on the way, a horned snake on the path that bites the heels of the horse, and its rider falls backward.” (Gen. 49:16)

It is not a very nice thing to say to your own son, especially as you lie there dying. But this is what Jacob said, and he said it would be for the “*last days*.” It is for this reason that many feel the Antichrist will come from the tribe of Dan. Look at its Gematria!

2376 = A horned snake on the path that bites the heels of the horse, and its rider falls.

What is this text doing in the 3:4:5 triangle that speaks of salvation through Jesus Christ?

Satan is the great counterfeiter. And his representative, Antichrist, would probably bear a number that is associated with the work of salvation. It appears that he sets himself up as Christ, and attempts to head a world government that supposedly promises peace to the world.

I suspect that somewhere in the text of the Old or New Testament, the number value of 2376 will be found, and it will relate to Jesus Christ and the work of redemption, or perhaps His work as King of the world government that He will establish from the throne of David. To date, I have not found it.

An example of the same number applying to Jesus Christ and to the Antichrist is found in Revelation 13:18. The text reads:

“Here is wisdom. Let him that hath understanding count the number of the beast: for it is the number of a man; and his number is six hundred threescore and six.”

2368 = And his number is six hundred threescore and six, και ο αριθμος αυτου χξξ'

2368 = Jesus Christ, Ιησους Χριστος

Let's return to the diagram and look at the next 3:4:5 triangle that it provides.

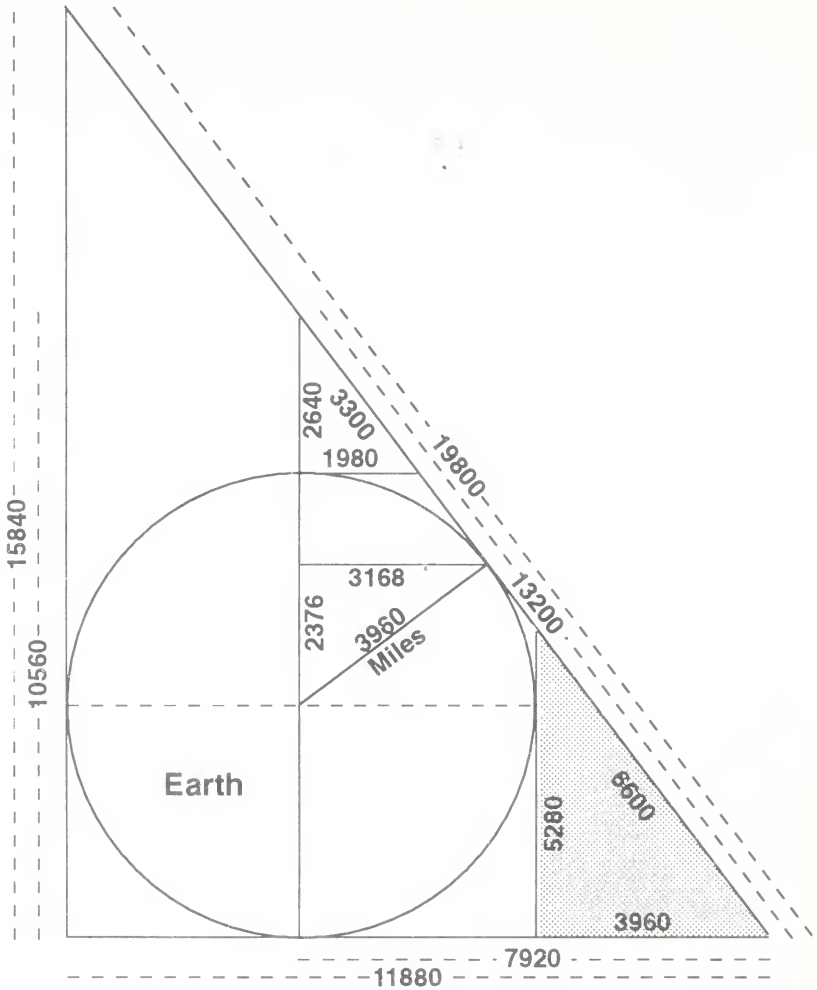

This triangle bears the three numbers, 3960, 6600, and 5280. We have already seen that the number 6 pertains to the earth and man; and 396 tells of salvation. We have also seen that the number 528 pertains to the time of Jesus return at the dawn of the great Third Day. It is the numeric value of The Key,

which opens the house of David. It is the numeric value for *"the breaking forth of light,"* (Hosea 6:3) and *"The day of His coming,"* (Malachi 3:2).

It is a day that is fast approaching, and for which we earnestly watch and pray. Malachi described it in dramatic terms:

"Behold, I am sending My messenger, and he shall prepare the way before Me. And the Lord, whom you seek, shall suddenly come to His temple, even the Angel of the Covenant, in whom you delight. Behold He comes, says Jehovah of hosts. But who can endure the day of His coming?"

The word *"suddenly"* sounds like it will come as a surprise to some. It reminds me of the words of Jesus that He gave to John in the vision of Revelation. He said, *"Behold I come quickly."* To those who have been waiting for nearly 2,000 years, the term *"quickly"* does not seem to describe reality. It is like the question my children used to ask when we were traveling to a distant place. They would often ask, *"Are we there yet?"* Time is a matter of perception. For a child, waiting for an expected event seems like an eternity. For the Christian, waiting anxiously for the return of their beloved Lord and Bridegroom, two thousand years seems like a very long time. But from Jesus' perception, he could say *"Behold, I come quickly."* We can answer as did John: *"Even so, come Lord Jesus!"*

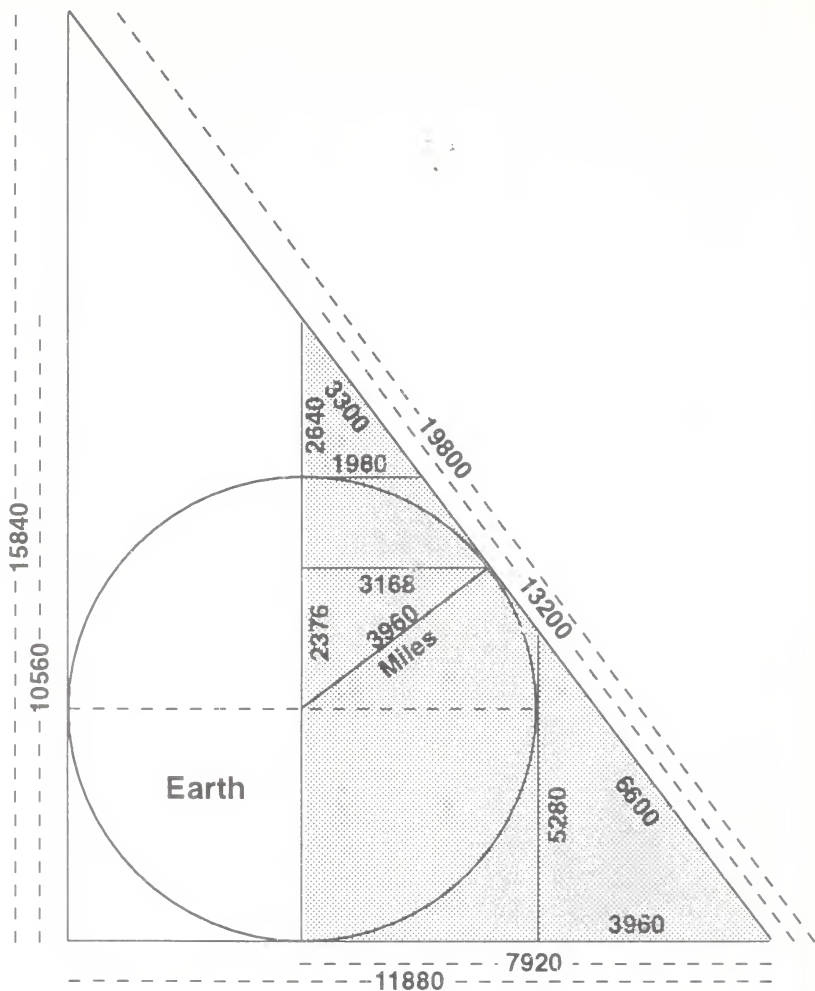

This 3:4:5 triangle includes the previous three. And it bears numbers that are indeed exciting! The height of this triangle follows the polar diameter of the earth. Its base is the same measure as the mean diameter of earth, 7,920 miles. This triangle shouts with the message of salvation and the Kingdom for which He taught us to pray.

- 792 = Lord Jesus Christ, אלהא יהושוע משיח
- 792 = Salvation, ישועות
- 792 = His going forth is established as the dawn
(Hosea 6:3)
- 1056 = The joy of thy salvation, ששון ישעך, (Psalm
51:12)
- 1056 = I will raise up the Tabernacle of David, רריד
אקים את-סכת, (Amos 9:11) (Prophetic of
Jesus' reign on David's throne.)
- 1320 = The fruit of thy womb, καρπος της κοιλιας
(This was spoken to Mary concerning the
child Jesus in her womb.)
- 1320 = Man, ανθρωποις, (Jesus became a man, the
Second Adam, that He might pay the penalty
for the sin of the First Adam.)
- 1320 = The stone cut out of the mountain, (Daniel
2:45) (Jesus, as the Stone, will set up His King-
dom in Jerusalem, which will grow and fill
the whole earth.)

The numbers in this triangle tell a beautiful story. It is the story of salvation through Jesus Christ. They tell of the King (Jesus) who will reign on David's throne – a kingdom that will break forth at the dawn of the great Third Day. It will start as a small stone, that will smite the great metal image of Gentile governments, and cause it to crumble and be blown away by the wind. Then that small stone will grow and fill the earth.

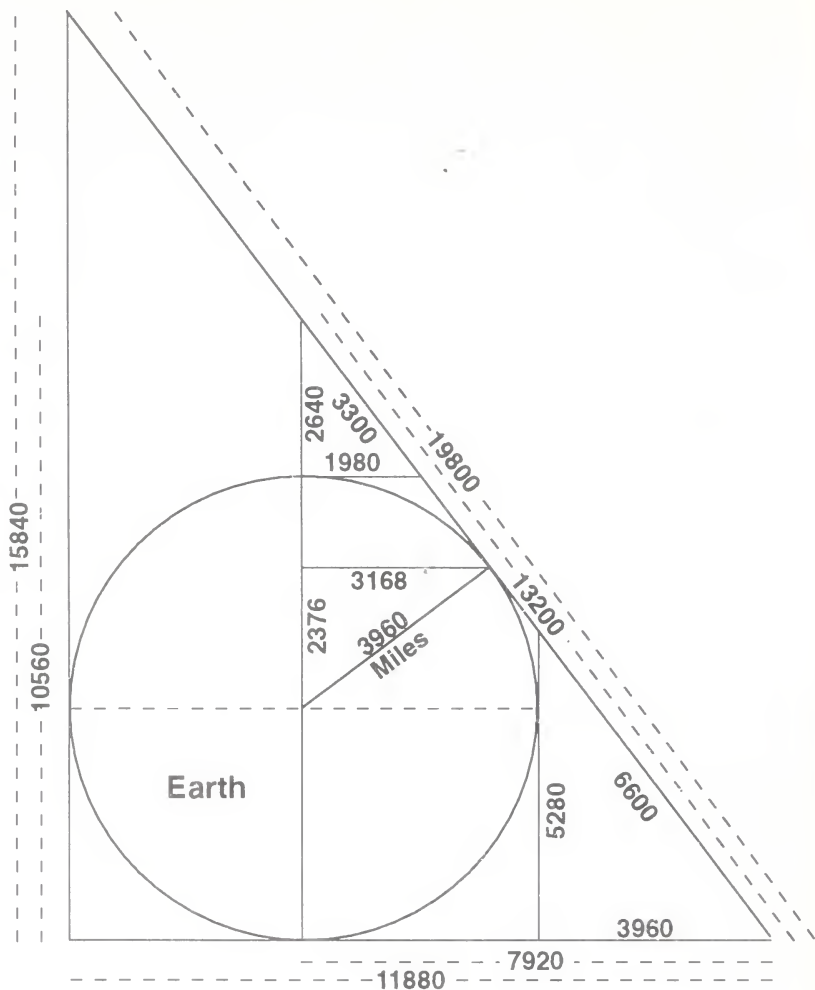

Finally we look at the large 3:4:5 triangle which encompasses the earth. Its dimensions are 11880 by 15840 by 19800.

It appears to describe God's completed plan for man upon this earth. Perhaps that is why it engulfs the earth within the triangle. That completed plan will be a world wide government of peace and pros-

perity, having its beginning in Jerusalem and going forth to bless the entire home of man.

A little foretaste of that Kingdom was given to Moses and recorded for us in Leviticus 26. This, of course, was a promise to the nation of Israel on the condition of their obedience.

“If you walk in My statutes, and keep My commandments, and do them, then I will give you rains in their season, and the land shall yield her produce, and the tree of the field shall give its fruit; and your threshing shall overtake the vintage, and the vintage shall overtake the sowing time; and you shall eat your bread until you have enough, and live in your land securely. And I will give peace in the land, and you shall lie down, and none shall make you afraid.” (Lev. 26:3-6)

We know the history. They did not obey, and so did not receive the blessing. Yet God did not make these promises in vain, and He always keeps His promises. If this is the reward for obedience, then when they return to Him in faithfulness and obedience, they surely will receive the promised blessing.

Zechariah gave us the hint that this beautiful promise of rain and abundance of produce will affect the rest of the world, as they come into obedience to the new laws of that Kingdom which will issue forth from Jerusalem. He wrote:

“And it shall be, everyone who is left from all the nations which came up against Jerusalem shall go up from year to year to worship the King, Jehovah of hosts, and to keep the feast of tabernacles. And it shall be, whoever will not go up from the families of the earth to Jerusalem to worship the King, Jehovah of hosts, even on them shall be no rain.” (Zech. 14:16-17)

God assured Moses that if Israel obeyed He would establish His covenant with them (Lev. 26:9) – it is an everlasting covenant of peace. How thrilling to find that *“I will establish my covenant,”* אֶת-בְּרִיתִי וְהִקְמֹתִי, has a numeric value of 1584. And the number of miles in the long side of this grand 3:4:5 triangle that engulfs the whole earth is 15,840 miles. No, it is not a coincidence – it was the careful planning of the Architect of the universe.

The focal place of that world government will be Jerusalem, and thus the Psalmist wrote:

“Beautiful for situation, the joy of the whole earth, is Mount Zion.” (Psalm 48:2)

Adding all the letter-numbers in this verse, we get the total of 1584.

The other two sides of the triangle bear numbers that are equally expressive of that Kingdom. They are 19800 and 11880 – part of a magnificent pattern!

198 = The King in his beauty, מלך ביפיו, (Isaiah 33:17) (descriptive of King Jesus on the throne of David)

198 = He is altogether lovely, כלו מחמרים, (Sol. 5:16) (Prophetic of Jesus)

1188 = The Glory of God, δόξα του Θεος

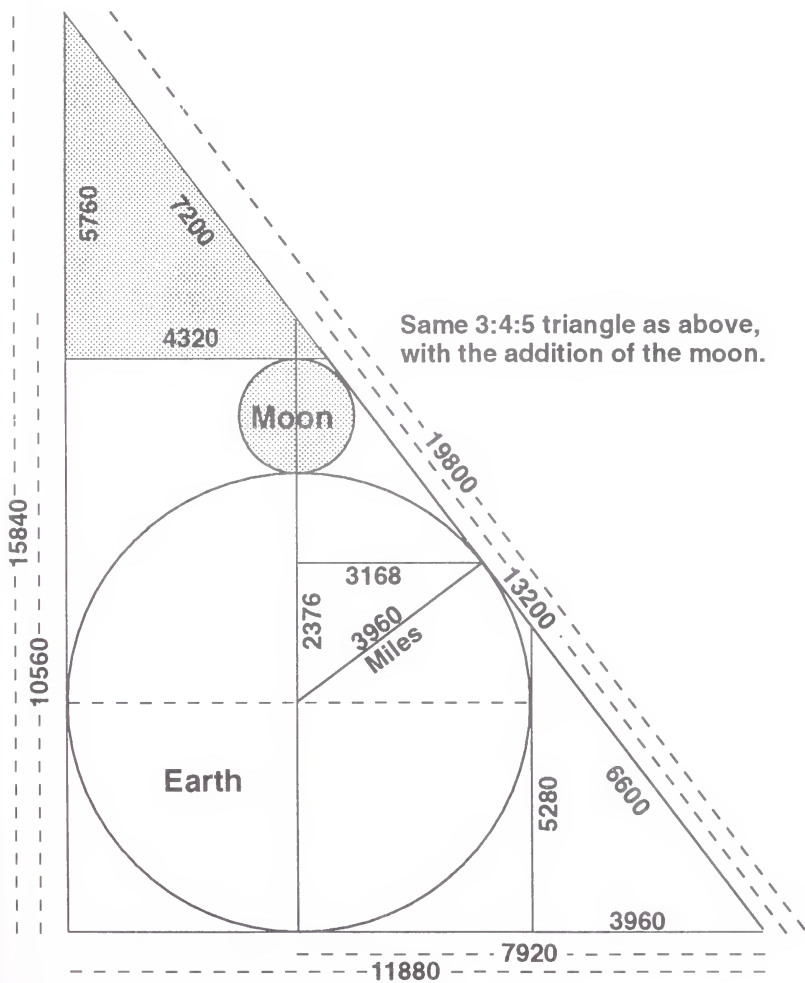

By placing the moon tangent to the earth, as we did in the earth-moon diagrams, we find the moon precisely fits into the triangle. It is apparently part of the pattern. And in doing so, it creates another 3:4:5 triangle with sides of 4320, 5760, and 7200. They are remarkable numbers, descriptive of the ending of 6,000 years of man's history, and the beginning of a new era – the era of the Kingdom of Jesus Christ.

The base of this very special triangle measures 4,320 miles. In the Gematria of the Bible, the number 432 pertains to the earth and its restoration to all that was lost in Adam – that restoration being made possible by the blood of Jesus Christ. The Apostle Paul stated it beautifully in Ephesians 1:10:

“In the dispensation of the fulness of times he might gather together in one all things in Christ, both which are in heaven, and which are on earth; even in him.”

Paul's all-inclusive term “*all things*” is the Greek word *panta*, παντα, which adds to 432. Other uses of this number show its reference to the earth as man's home.

432 = All things, παντα

432 = Habitation, κατοικια

432 = The habitable world, תבל

432 = All nations, כל-גוים, (by multiplication)

Other uses of 432 reveal its reference to the Kingdom of peace that Jesus will establish in the earth when He, as *“The Branch of Jehovah”* will grow up out of the root of David, and will take His place as the King on David’s throne.

432 = The Branch of Jehovah, צֶמַח יְהוָה, (Isaiah 4:2)
(by multiplication)

432 = The Saviour, מוֹשִׁיעַר, (Jer. 14:8)

432 = Our peace, שְׁלוֹמֵנו, (Isaiah 53:5)

432 = He shall lead them by springs of water, מַיִם
יְנַהֲגֵם וְעַל-מְבוּעֵי, (Isaiah 49:10)

432 = Jerusalem, יְרוּשָׁלַם, (by multiplication)
(Jerusalem will be the seat of that government
of peace.)

Zechariah prophesied concerning this Kingdom of Peace which would be under the administration of the One whose name is The Branch – the One who will be both priest and king.

“Behold! The Man whose name is The Branch! He will grow up out of His place, and He shall build the temple of Jehovah. Even He shall build the temple of Jehovah. And He shall bear the majesty and shall sit and rule on His throne; and He shall be a priest on His throne; and the counsel of peace shall be between them both.” (Zechariah 6:12-13)

The height of this remarkable 3:4:5 triangle measures 5,760 miles. According to the Hebrew calendar, the world has just entered into the year 5760. As shown earlier, the Hebrew calendar differs from the Gregorian by 240 years. Thus the year 5760 also completes the 6000th year from Adam – it marks the ending of the great six days of man’s right of rulership. And, as also shown earlier, the Hebrew words for “six days” multiply to 5760. It appears to be conveying to us the message that the six full days (one day equals a thousand years) would bring us to the year 5760.

Days Six
 י מ י ם ש ש ת
 $40 \times 10 \times 40 \times 10 \times 400 \times 300 \times 300 = 5760$
 (dropping the rest of the zeros)

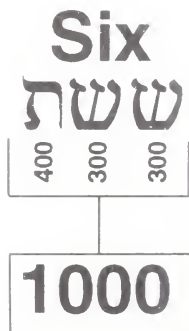

Third Day

י ו ם ת ל ת ה

$$5 \times 400 \times 30 \times 400 \times 40 \times 6 \times 10 = 5760$$

(dropping the rest of the zeros)

That the third day and the seventh day are the same day, is shown in the diagram below. Thus the juncture of the ending of the six days and the dawning of the third day is marked by the year 5760 on the Hebrew calendar.

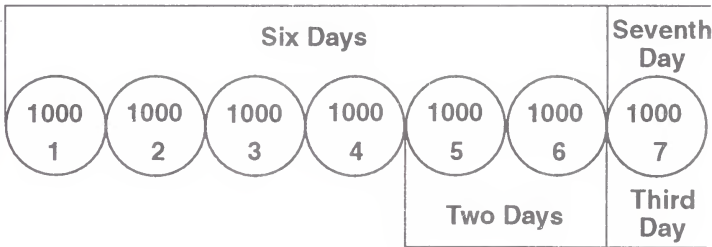

Isaiah used descriptive words when he prophesied of this Kingdom of Peace, which will be on the great Third Day. He said:

“God is my salvation! I will trust and not be afraid, for my strength and my song is Jah Jehovah; yea, He has become my salvation. And you shall with joy draw waters out of the wells of salvation. And in that day you shall say, ‘Praise Jehovah! Call on His name; declare His

doings among the people; make mention that His name is exalted. Sing to Jehovah, for He has done majestically; this is known in all the earth.’” (Isaiah 12:2-5)

Encoded within the text is the year when the right of rulership is transferred from man to the One who will sit on David’s throne – the year 5760. For the phrase “*Wells of Salvation*,” has a numeric value of 576. It does not necessarily mean that the drawing of water from the Wells of Salvation will begin immediately that the year 5760 arrives. It more likely means that the year 5760 is the pivotal year in which the transfer of the right of rulership takes place, and it is given to “*Him whose right it is.*” It begins the great Third Day in which this Kingdom of Peace will be established.

There are other indications that this number, 5760, begins the era in which His kingdom will be established in the earth. These things do not all begin in the year 5760 – it merely marks the point of transition. The list is exciting!

576 = Wells of Salvation, מעיני הישועה

576 = Life, πνευμα

576 = In God is my salvation, על אלהים ישעי,
(Psalm 62:7)

576 = Eternal redemption, αιωνιαν λυτρωσιν, (Hebrews 9:12) (by multiplication)

- 576 = Messiah the Prince, משיח נגיד, (Daniel 9:25)
(by multiplication)
- 576 = The Way of Holiness, ודרך הקדש, (Isaiah 35:8) (by multiplication) (It is a metaphor describing the way by which mankind will come into harmony with the righteous laws of the Kingdom.)
- 576 = His Kingdom, מלכות, (by multiplication)
- 576 = Prepared as the dawn, כשחר כון, (Hosea 6:3)
(by multiplication) (This is a prophecy of the restoration of the nation of Israel "after two days" or "on the third day.")
- 576 = He shall appear in His glory, נראה בכבודו, (Psalm 102:16) (by multiplication) (This is prophetic of the time when He comes with His saints to turn back Israel's enemies and put an end to Armageddon.)
- 576 = The Lord my God and all the saints, קדשים-
כל יהוה אלהי כל, (Zechariah 14:5) (Prophetic
of the time when He comes with his saints to
save Israel from her enemies.)
- 576 = Signs, מופתים, (Joel 2:30) (*"And I will give
signs in the heavens, and in the earth: blood
and fire and columns of smoke. The sun shall
be turned to darkness and the moon to blood,
before the coming of the great and awesome
day of Jehovah,"* (KJV)
- 576 = The moon into blood, η σεληνη εις αιμα, (Acts 2:20) (*"The sun shall be turned into darkness*

and the moon into blood, before that great and notable day of the Lord come.”)

576 = Trumpet, תְּקוּעַ, (Ezekiel 7:14) (The blast of a trumpet.)

The list is indeed impressive! And as can easily be seen, all of the events and conditions depicted do not take place in the year 5760. That year marks the pivotal point in man's history when man's lease of rulership has expired. The events shown in the above list all occur on or following that date.

The date 5760 marks the end of 6,000 years of man's allotted rulership of earth. It marks the appointed time for the new Ruler. It is the time of the transfer of the right of rulership. Thus it is fitting that the exclamation, "*Behold, your King,*" הִנֵּה מֶלֶךְ, (Zechariah 9:9) multiplies to 6000. The completion of the year 6,000 is the time for the transfer of the right of rulership.

This does not mean that the rulers of this world will hand over their power when their lease expires. They will not give up without a fight.

“The kings of the earth set themselves; yea, the rulers have plotted together against Jehovah and His anointed, saying, We will break Their bands in two, and throw off Their cords from us. He who sits in the heavens shall laugh; Jehovah shall mock at them. Then He will

speak to them in His anger; and He will trouble them in His wrath. Yea, I have set My king on My holy mount, on Zion.” (Psalm 2:2-6)

Zechariah told us what would happen to the nations when this appointed King will take up His rulership:

“And the battle bow shall be cut off, and He shall speak peace to the nations. And His dominion shall be from sea to sea, and from the river to the ends of the earth.” (Zechariah 9:10)

There is one more side to this amazing 3:4:5 triangle – it is the hypotenuse. It measures 7,200 miles.

Every school girl or boy learns the formula for the right triangle in geometry class. They know that the squares of the two sides equal the square of the hypotenuse. The square of the hypotenuse of this very special 3:4:5 triangle tells us about the long-awaited return of Jesus. $72 \times 72 = 5184$. It is a very special number.

5184 = “Behold, I am sending my messenger, and he shall prepare the way before Me. And the Lord, whom you seek, shall suddenly come to His temple, even the Angel of the Covenant, in whom you delight. Behold, He comes.”
(Malachi 3:1)

We have seen the earth and moon within the 3:4:5 triangle. Now let's do the same thing with the sun. In the diagram below, the zeros have been dropped, making the measures appear much smaller than they actually are.

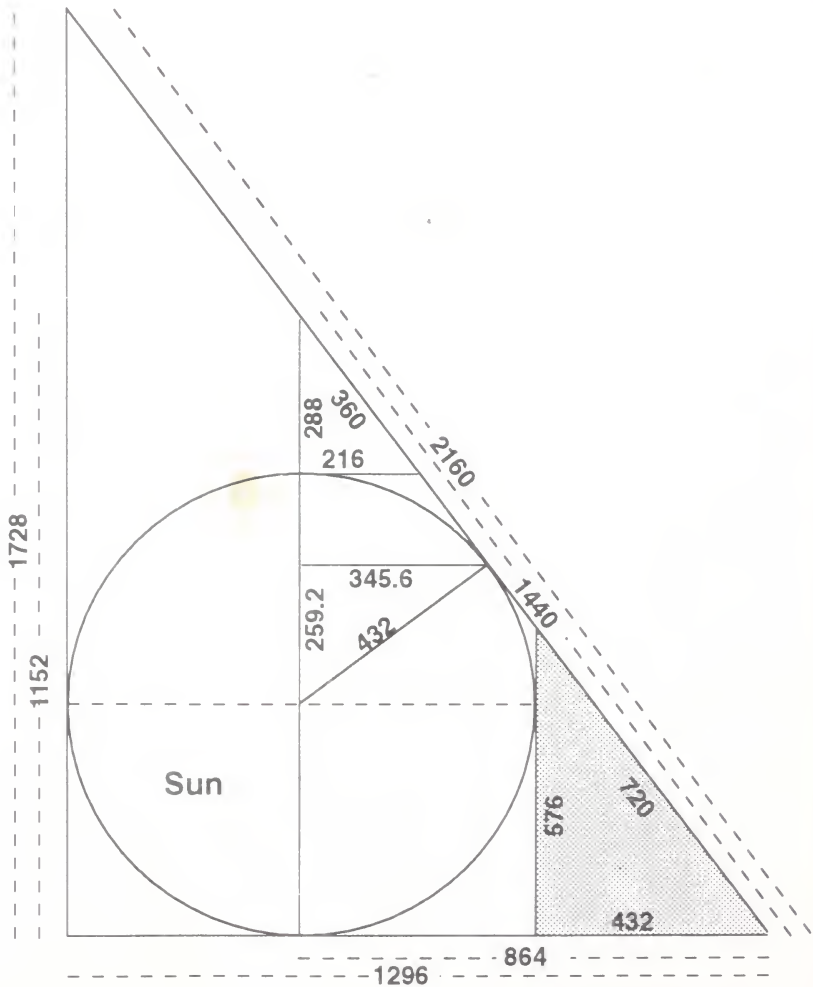

Notice the triangle that is highlighted. It bears the same numbers as the top triangle in the previous diagram (with earth and moon), with, of course, the three zeros dropped.

All of the measures in this diagram produce numbers that are used in the sacred number patterns of the Bible. I will not deal with all of them here. Many of them were also in the earth-moon triangle. However, one triangle especially attracts my attention. It is the 3:4:5 triangle within the circle of the sun, drawn on the sun's radius, which is 432,000 miles. The two sides of this triangle are 259.2 and 345.6. Quite remarkable numbers!

I have already mentioned that the sun passes through all twelve signs of the zodiac in 25,920 years. This is called the Grand Celestial Cycle, or the Great Year. It was thrilling to find that the names of these twelve signs bear numbers that relate to 25920.

Virgo	145 = virgin, עלמה
Libra	56 = balances, מאזני
Scorpio	372 = scorpion, עקרב
Sagittarius	171 = horse-man, אדם-סוס
Capricornus	580 = goat, שעיר
Aquarius	180 = "waters flow from His buckets," מים מרליו (Numbers 24:7)
Pisces	12 = fish (female fish), דגה
Aries	41 = ram, איל
Taurus	250 = reem, רים
Gemini	441 = twins, תאם
Cancer	261 = "to bind together," אסר
Lion	83 = lion, לבאים (roaring lion)
	<u>2592</u>

This number 25920 is prophetic of the time when "He whose right it is" rules from David's throne.

25920 = The heart of Jerusalem, לב ירושלים, (Isaiah 40:1) (by multiplication) (Jerusalem will be the seat of government in the Kingdom of Peace.)

25920 = As the latter rain, former rain, יורה כמלקוש, (Hosea 6:3) (by multiplication) (A metaphor for the life-giving function of that Kingdom.)

The Author of Creation is a marvelous mathematician. This path of the sun through the Zodiac, which so beautifully relates to the Kingdom of Peace that will grow out from Jerusalem to all the world, provides a geometric relationship that is awesome!



8251 = "In Him was life, and the life was the light of men," εν αυτω ζωη ην και η ζωη ην το φως των ανθρωπων, (John 1:4)

If we were to divide the diameter of the above circle by its circumference, the result would be .318, which is the number used in the New Testament for the sun. We've gone way beyond coincidence. We are in the magnificent area of evidence.

$$8,251 \div 25,920 = .318$$

318 = Sun, *ηλιος*

But – wonder of wonders – the name of the Author of Creation bears the same number. And He is indeed represented by the sun, which is the source of all life on this planet.

318 = The God of gods and Lord of lords, *האֱלֹהִים וְאֵלֹהֵי*
וְאֵלֹהֵי וְאֵלֹהֵי, (Deuteronomy 10:17)

This same title, when multiplied, produces the number 2160, which is the number of years that the sun remains in each of the twelve signs of the Zodiac. And when we divide the diameter of the Zodiac circle by the Golden Proportion twice, we find the answer is 2160.

$$8251 \div .618 \div .618 = 2160$$

2160 = The God of gods and Lord of lords (by multiplication)

The number 2160 is used often in the Gematria of the Bible. It is the measure of the diameter of the moon, in miles. And it also pertains to the right of dominion that belongs to Jesus.

2160 = His dominion, מִשְׁלוֹ, (Zechariah 9:10) (by multiplication)

216 = All nations shall serve Him, גוֹיִם יַעֲבֹדוּהוּ כָל, (Psalm 72:11)

The long side of the 3:4:5 triangle that is drawn on the radius of the sun bears a number that relates to the completed plan of God for the salvation of man. It is 3456. If we were to enclose the sun in a square, its perimeter would be 3,456,000 miles. Both by addition and by multiplication, this number shows the all-inclusive completeness – the ultimate magnitude – of all the works of God, from the beginning to the fulness of the New Beginning through Jesus Christ.

By addition:

3456 = Alpha and Omega, the beginning and the end, *αλφα και το Ω η αρχη και το τελος*, (Rev. 1:8)

3456 = The city of my God, *της πολεως του Θεου μου*, (Rev. 3:12) (The New Jerusalem)

3456 = The marriage of the bride and Lamb, *ο γαμος του αρνιου και η γυνη αυτου*, (Rev. 19:7)

By Multiplication:

- 3456 = His Kingdom, מלכותו, (Psalm 145:13)
- 3456 = His dominion, ממשלתו, (Psalm 103:22)
- 3456 = All His works, כל-מלאכתו, (Genesis 2:3)
- 3456 = All your wonderful works, כל נפלאותיך,
(Psalm 26:7)
- 3456 = The Feast of Tabernacles, חג הסוכות, (Zech.
14:18) (Picturing the work of the great Third
Day.)
- 3456 = Repairer of the breach, גרר פרץ, (Isaiah
58:12) (Prophetic of Jesus as Ruler and Pro-
tector of Israel.)
- 3456 = Truth, ἀληθης (Jesus is the personification
of truth.)

The righteousness and peace of the Kingdom, under the administration of Jesus Christ, will be world-wide in its scope.

“And it shall be, everyone who is left from all the nations which came up against Jerusalem shall go up from year to year to worship the King, Jehovah of hosts, and to keep the feast of tabernacles.” (Zechariah 14:16)

“For as the new heavens and the new earth, which I shall make, stand before me, says Jehovah, so your seed and your name shall stand. And from new moon to its new moon,

and from sabbath to its sabbath, all flesh shall come to worship before Me, says Jehovah."

(Isaiah 66:22-23)

The "new heavens and new earth," **רְהוּרָץ הַשָּׁמַיִם הַחֲדָשִׁים**, multiplies to 248,832 (zeros dropped). By the rules of Gematria it is the same as the mean circumference of the earth, which is 248,831.392 miles. Thus, hidden in the Number Code, is the assurance that the Kingdom encompasses the whole earth.

The Apostle John saw this New Heaven and New Earth in vision. He said:

"And I saw a new heaven and a new earth ... and I, John, saw the holy city, New Jerusalem, coming down from God out of heaven,"

(Revelation 21:1-2)

He described the city he saw in vision as being like a giant cube, coming down and engulfing the earth. It had three gates on each side, making 12. On each gate was inscribed the name of one of the tribes of Israel. The city had twelve foundations, which were the names of the twelve Apostles.

John described the city as a cube with a ground plan of 12,000 furlongs per side, with a spherical wall enclosed within. When we convert furlongs to feet, we find that the measure of the New Jerusalem (in feet) exactly matches the measure of the earth (in miles). It is evidence that they both had the same Author.

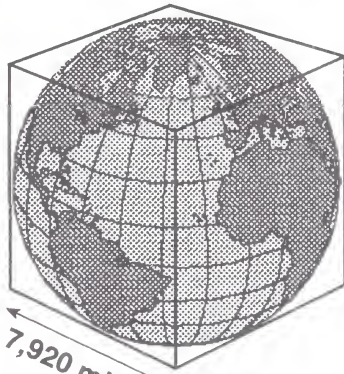

Earth

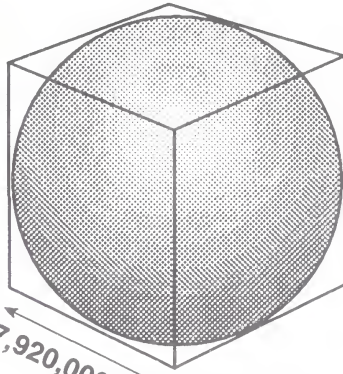

New Jerusalem

248,832 = New heavens and new earth
 248,831.392 miles, circumference of earth.

This New Jerusalem comes down from heaven and engulfs the whole earth. It is the new Kingdom, which is ruled from above, but initially is set up in Jerusalem and eventually grows to fill the earth.

Its twelve gates bore the names of the twelve tribes of Israel. Thus it bore the number 10656.

Judah	<i>Ιουδα</i>	485
Reuben	<i>Ρουβην</i>	630
Gad	<i>Γαδ</i>	8
Asher	<i>Ασηρ</i>	309
Nephtalim	<i>Νεφθαλειμ</i>	650
Manasses	<i>Μανασσης</i>	700
Simeon	<i>Συμεων</i>	1495
Levi	<i>Λευι</i>	445
Issachar	<i>Ισσαχαρ</i>	1112
Zebulon	<i>Ζαβουλων</i>	1360
Joseph	<i>Ιωσηφ</i>	1518
Benjamin	<i>Βενιαμιν</i>	168
		<hr/>
		8880

8880 x 12,000 from each tribe = 106,560,000

The foundations of the city were the twelve Apostles. Amazingly they bore the same number, 10656.

Peter	Πετρος	755
Andrew	Ανδρεας	361
James	Ιακωβος	1103
John	Ιωαννης	1119
Philip	Φιλιππος	980
Nathanael	Ναθαναηλ	150
Levi (Matthew)	Λευι	445
Thomas	Θωμας	1050
James (son of Alphaeus)	Ιακωβος Αλφαιου	2115
Lebbaeus (Thaddeus)	Λεββαιος	320
Simon the Canaanite	Σιμων ο καναναιος	1573
Judas	Ιουδας	685
		10656

It is not just a coincidence that the twelve foundations and the twelve gates bear the same number. In the vision that was given to John, it was Jesus who spoke to him and said:

“And I will write on him the name of my God, and the name of the city of my God, the New Jerusalem.” (Revelation 3:12)

If we add all the number equivalents for this statement in the Greek text, it will total 10656. It was not a random number. It was part of the encoded text. It is the number of Jesus – 888 – multiplied by 12. The number twelve is the great foundation number of the whole work of creation. It is displayed in the 3:4:5

triangle. Add the sides of this triangle, and it produces the number 12. It has been demonstrated that the principle of the 3:4:5 triangle has been basic to the geometry of the earth, sun and moon – it bears the number 12.

The Hebrew word מוֹסֵרִי is translated “*Foundation*.” It has a numeric equivalent of 120. The Hebrew word מוֹכֵלֵל is translated “*Perfection*.” It also has a numeric value of 120. It is basic to the pattern of creation.

At the end of the six days of creation, it is recorded in Genesis 1:31:

“And God saw everything that He had made; and, behold, it was very good! And there was evening and there was morning, the sixth day.”

“*Very good*” by God’s perception would be nothing less than perfection. The foundation of all creation began in perfection, as is shown by the number 12. The numbers in the geometry of the earth, sun and moon are all multiples of 12 – they are built upon the foundation of 12. Thus, the multiplication of 12 times the number of Jesus’ name, 888, produces 10656, the number of the completed plan of God for the salvation of man and the restoration of all that was lost in Adam.

That Kingdom which has its beginning in Jerusalem and grows to fill the earth will, in reality, be the completed work of transferring the dominion, or

rulership, from man to Jesus Christ. It is said of Him:

“For He must reign until He has put all enemies under His feet.” (I Corinthians 15:25)

Add all the letter-numbers in this statement, and they will total 8888. It is Jesus, the great number 8 who brings to this earth a New Beginning.

The thought that preceded the above verse conveys the message – Jesus will put down all of man’s rulership, all of man’s power, all of man’s authority.

“Then cometh the end ... when He shall have put down all rule and all authority and power. For He must reign, until He hath put all enemies under His feet.”

Today, we stand on the threshold!

Appendix 1

The Elusive Millennium Date

When does the twenty first century and the third millennium begin?

Judging by the celebrations that followed the midnight hour around the world on December 31, 1999, obviously many felt that the year A.D. 2000 was of special importance, a key date in the history of man.

However, now that the fireworks are over and the smoke has cleared, the world has settled down to the realization that perhaps we were a year premature.

The controversy arises with the indisputable fact that our A.D. dates do not begin with a zero year, they in fact, begin with year 1. This is because the concept of zero, as separating minus numbers from plus numbers was not in use at the time this system of dating was developed. Thus, beginning our A.D. era with the year 1, we must calculate centuries and millennia as beginning with 1 and not 0.

The term A.D. is an abbreviation for the latin words *Anno Domini*, meaning "in the year of our Lord." If we were to calculate the true zero point for the beginning of the counting, we would have to place it on the date of Jesus' birth – and He was *not* born January 1, A.D. 1.

If the years had begun with zero, we would indeed have passed the date-line and into the 21st century and the third millennium. But does that make the celebrations a year premature? I do not believe so.

Our current system of counting B.C. and A.D. years looks like this:

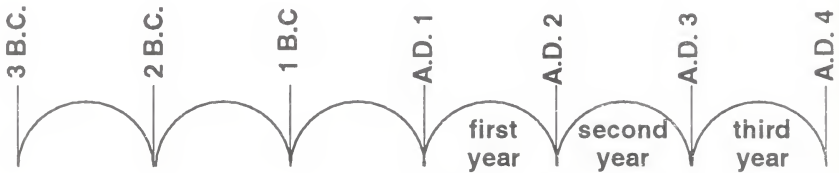

However, Jesus was actually born a year and three months before our current A.D. 1 date. Thus the first full year, using our January to January calendar, would be the time between 1 B.C. and A.D. 1. This would place the transition from December 31, 1999 to January 1, 2000 indeed into the 21st century and the third millennium.

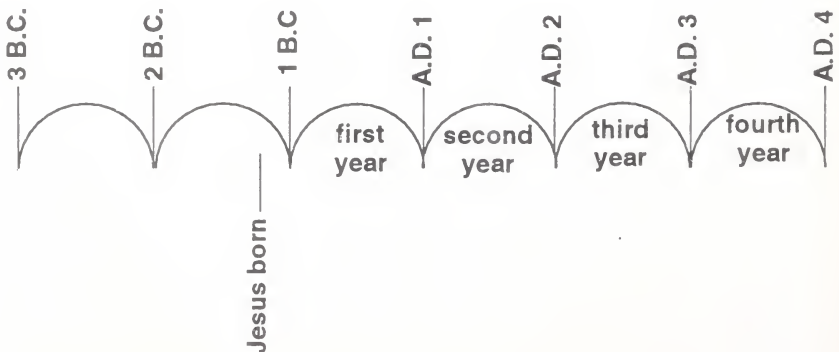

Appendix 2

Gematria – how it works

All creation, from the largest to the smallest, can always be reduced to numbers. Pythagoras, the father of mathematics, discovered a great truth when he said “Numbers are the language of the universe.” In the writings of the ancient philosophers there is common agreement that the purpose of number is for the investigation of the universe. From the atom to the galaxy in the heavens, the same unchanging laws apply – the laws of arithmetic, the language of number.

Just as the hand of God spread the vast expanse of the heavens by number, so too His written word can be reduced to number; and those who have tried it have stood in awe of the intricacy and beauty of the design. It was an intentional design.

The secrets locked up in the Number Code of the Bible are there for all to behold; and down through the centuries many have unlocked those secrets and revealed to us the unspeakable beauty of the intended design. Part of the numerical design of the scriptures is the science of Gematria.

The Old Testament was originally written in the Hebrew language, and the New Testament in Greek.

These two languages used the letters of their alphabets as symbols for amount. Their alphabets were called “dual character systems” – one of sound, or phonetics, and the other of amount, or number.

Tobias Dantzig, a professor of mathematics at the University of Maryland (U.S.A.) explained the phenomenon thus:¹

The sum of the numbers represented by the letters of the word was the number of the word, and from the standpoint of Gematria two words were equivalent if they added up to the same number. Not only was Gematria used from the earliest days for the interpretation of Biblical passages, but there are indications that the writers of the Bible had practiced the art. Thus Abraham proceeding to rescue his brother Eliasar drives forth 318 slaves. Is it just a coincidence that the Hebrew word Eliasar adds up to 318?

Within the first century A.D., Barnabas, the traveling companion of the Apostle Paul, wrote concerning this number code.

For the scripture says that Abraham circumcised three hundred and eighteen men of his house. But what therefore was the mystery that was made known unto him? Mark, first the eighteen, and next the three hundred. For the numeral letters

1 Tobias Dantzig, *Number, the Language of Science*, Doubleday Anchor Books, New York, NY, 1930, p. 40.

of ten and eight are I H. And these denote Jesus. And because the cross was that by which we were to find grace; therefore he adds three hundred; the note of which is T (the figure of his cross). Wherefore by two letters he signified Jesus, and by the third his cross.

Barnabas leads us to realize that the knowledge of the use of Gematria in the word of God is not something of modern discovery.

One of the best known demonstrations of Gematria in the Old Testament is the section headings in Psalm 119. Any student of the Old Testament is aware that the names for these sections are in fact the sequential letters of the Hebrew alphabet. These letters were simply used to number the sections. In some Bibles the word for the letter is spelled out, (such as *aleph*); while in other translations, the single letter is used (such as א) – both of these translate, by Gematria, to the number 1.

Gematria among the Greeks was in common use at the time of the writing of the New Testament. A copy of one of these early manuscripts, called *papyri*, (because they were written on papyrus) exists today in Dublin, Ireland in the Chester Beatty Collection. It is the earliest known copy of the book of Revelation extant. It is dated somewhere between 200 and 300 A.D. This manuscript uses Gematria for every number in the book of Revelation, rather than Arabic numerals as we have in our modern translations.

The re-discovery of these Number Codes is not new. The noted Bible expositor, E. W. Bullinger, was among the many who have added to our understanding of this subject. His book *Number in Scripture*, published in 1894, shows the supernatural design in the use of numbers, both in the works of God and in the word of God.

The number equivalents for the Greek alphabet can be found in any Webster's Dictionary.

The Greek alphabet used twenty six letters, two of which have become extinct. The current twenty four are listed below:

Alpha	α	1
Beta	β	2
Gamma	γ	3
Delta	δ	4
Epsilon	ϵ	5
Zeta	ζ	7
Eta	η	8
Theta	θ	9
Iota	ι	10
Kappa	κ	20
Lambda	λ	30
Mu	μ	40
Nu	ν	50
Xi	ξ	60
Omicron	\omicron	70
Pi	π	80
Rho	ρ	100
Sigma	σ ς	200
Tau	τ	300
Upsilon	υ	400
Phi	ϕ	500
Chi	χ	600
Psi	ψ	700
Omega	ω	800

There were once letters for 6 and 90, but they became obsolete through time, and finally dropped from the alphabet. The letter standing for the number 6 was called “stigma.” It looked similar to sigma. I cannot show it here because it is not in the Greek font on my computer. The only use for the letter stigma in the New Testament is in Revelation 13:18 where it gives the number of the beast. In the old manuscripts, it was written as $\chi\xi\xi = 600, 60, 6$.

There were twenty two letters in the Hebrew alphabet, as follows:

Aleph	א	1
Beth	ב	2
Gimel	ג	3
Daleth	ד	4
He	ה	5
Vav	ו	6
Zayin	ז	7
Cheth	ח	8
Teth	ט	9
Yod	י	10
Kaph	כ	20
Lamed	ל	30
Mem	מ	40
Nun	נ	50
Camek	ס	60
Ayin	ע	70
Pe	פ	80
Tsadey	צ	90
Qoph	ק	100
Resh	ר	200
Shin	ש	300
Tav	ת	400

Notice there are five finals. These letters are shaped differently when they appear as the final letter in a word. In the Cabala these five finals are given higher numbers, namely, 500, 600, 700, 800, and 900. In

my search of the Gematria of the Bible, I do not find this additional assigning of the numbers to be part of the original design. It was an addition to the system, which was adopted later.

It should be noted that according to the rules of Gematria, one unit called *coel* could be added or subtracted from a word or phrase without changing its meaning. I have avoided the use of *coel* in this book.

Appendix 3

The Golden Proportion

The Golden Proportion, sometimes called the Divine Proportion, has come down to us from the beginning of creation. The harmony of this proportion is built into the very structure of nature.

Plato called it the most binding of all mathematical relationships and the key to the physics of the cosmos. The Golden Proportion is a very special kind of unity which can be expressed in two terms. In geometry, this can only occur when the smaller term is to the larger term as the larger term is to the smaller plus the larger. That may sound confusing, but it can be illustrated by a simple example.

Divide a line



at a point C



in such a way that the whole line AB is longer than AC in the same proportion that AC is longer than CB.

To a mathematician, the Golden Proportion is written as $a:b::b:(a+b)$, thus the largest term $(a+b)$ is a wholeness, or unit, composed of the sum of the other two terms. Thus when Unity is divided, that which is separated becomes part of the whole. The ratio is 1:1.618. It can be shortened to .618, which can be carried out to more decimal places for accuracy (.618034). In mathematics, the Greek letter ϕ (pronounced phi) is used as a symbol of this proportion.

In the book of Genesis it is said that God divided the light from the darkness. By using Gematria, it becomes obvious that this division was by use of the Golden Proportion. *“God divided between light and darkness, and God called the light day, and the darkness he called night.”* The numeric values for “day” and “night” reveal the use of the Golden Proportion.

	היום ובין the day and	הלילה the night	
A	129	C	B
•	(1)	•	•

The next division was of water. He divided the waters above the expanse from the water below the expanse. The wording defines the Golden Proportion.

	המים אשר מתחת לרקיע The waters which were under the expanse.	מעל לרקיע המים אשר The waters which were above the expanse	
A	1854	C	B
•	(1)	•	•

Combining the two portions (1854 + 1146) we find the total to be 3000. Showing this as a Golden Rectangle reveals the six creation “days” and the six thousand year lease of man’s dominion.

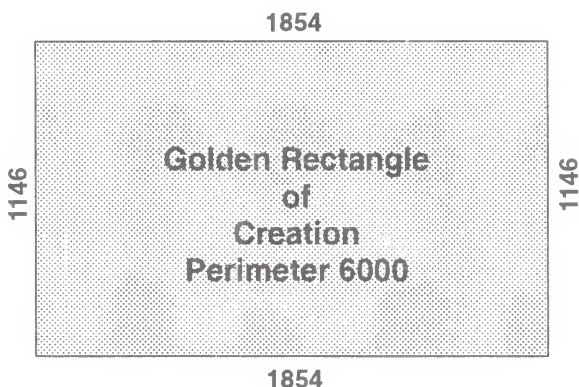

The Golden Proportion is the very foundation principle of creation. It is built into the six days of creation; into the six days of man’s right of rulership on this earth; into the size relationships of earth and moon; into the prophecies relating to Jesus and His work of redemption; into the formation of all plant and animal life; and, yes, into the formation of man, himself. Our bodies are replete with the Golden Proportion.

Within a Golden Rectangle, by connecting the corners with quadrants of a circle, we can trace a beautiful spiral, known as the Golden Spiral. This spiral is the growth principle in all creation. It increases in size by a mathematical progression, but always retains its shape. This mathematical progression is

known as the Fibonacci progression, named after its discoverer, Leonardo Fibonacci, in the 12th century A.D. Its principle is simple. It begins with the number 1, then duplicates the 1. From thence we merely add the last two numbers to produce the next number in the series. Thus we produce:

1 1 2 3 5 8 13 21 34 55 89 144 etc.

This beautiful proportional progression is found throughout nature. We witness it every day, but are not aware of it. The arrangement of leaves on the stems of plants often follow the Fibonacci progression.

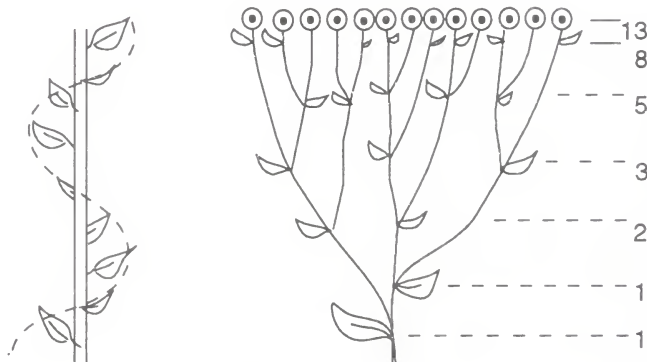

The world around us is replete with Golden Spirals. We pass by them every day, we walk over them, we see them in the sky at night.

The progression of this spiral can be seen in the nautilus shell. As the nautilus grows, it increases in size but retains the same shape.

This spiral can be seen in the seed pattern of most daisies, and is most obvious in the seed pattern of the sunflower.

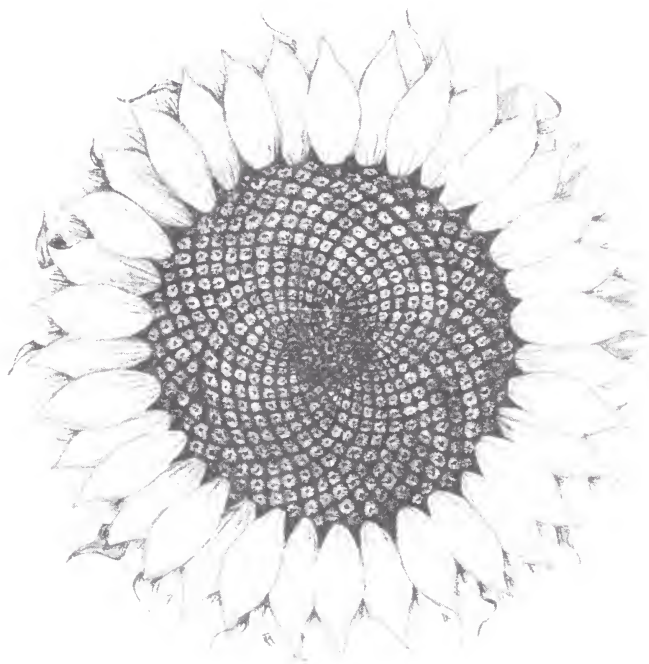

The arrangement of the seed pattern of the sunflower are interwoven Golden Spirals turning both left and right.

What beautiful evidence of a Divine Creator, a Designer who has woven His designs into all of His creation!

That design was built into man. The human body is built upon the principles of the Golden Proportion. The drawing by Leonardo da Vinci shows the human body in its relation to a circle and a square. The same

as we see in the relationship of earth to its moon.

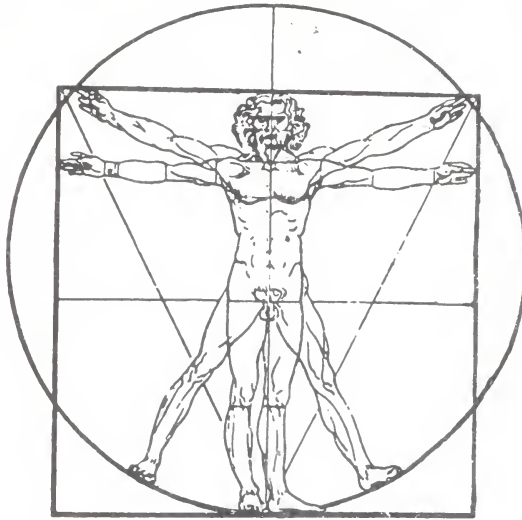

The center of the circle is at the navel.
The center of the square is at the sex organ.
Thus the human body is divided in half at the
sex organ and divided by the Golden
Proportion at the navel.

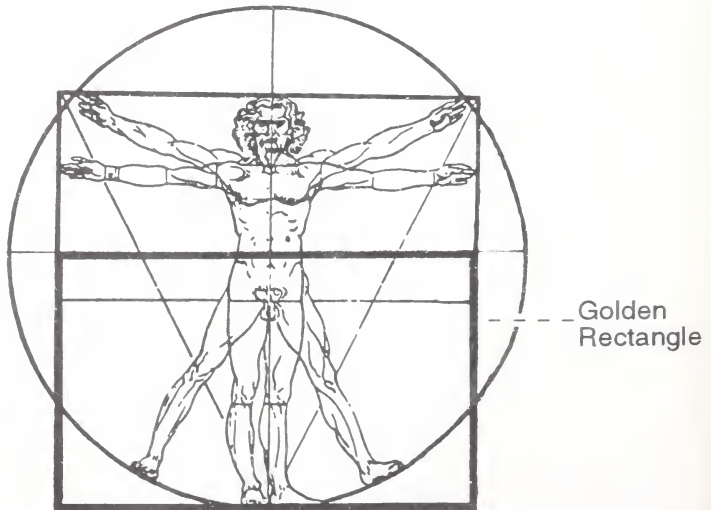

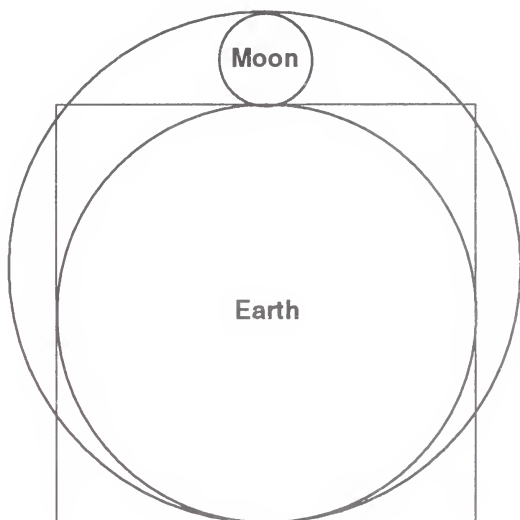

When a human child is born, his navel defines the half-way point of his body, (the center of the circle) but when he reaches adulthood, the navel defines the Golden Proportion and the sex organ defines the half-way point, (center of the square). Thus, in an adult human, the sex organ, the means of reproduction, is placed at the very center of the earth in the above commensurate diagram. But the navel, representing the place from which we originated – that which is attached to our Maker – is defined by the Golden Proportion. It is probably the best means of understanding how man (an earth creature) was made in the “*image and likeness of God.*”

This relationship of man to his home, earth, and to his Creator is not a chance encounter. It was the beautiful design of a Master Designer.

Because of the relationship of the pentagram to the Golden Proportion, the Pythagoreans wore it as a symbol of their society. Pythagoras, however, did not invent it, nor discover it. The pentagram was used by the Babylonians and the Egyptians long before Pythagoras. But its beautiful display of the Golden Proportion tells us that it is part of the fabric of creation.

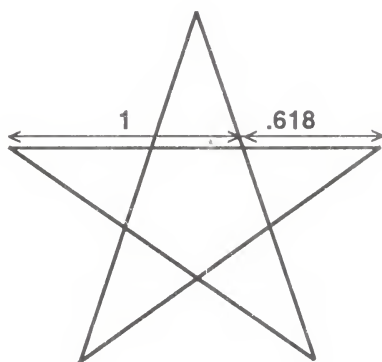

A five-pointed star is not easy to draw. But the process by which it can be drawn is a magnificent display of the works of the One who made the earth and all creation. He has placed His signature on it.

To construct a five-pointed star, we begin with a square with sides of 1 unit. Next, we extend one side of the square to form a Golden Rectangle. Using this Golden Rectangle as a base, with compass and straightedge, a pentagon can be drawn that will have sides of 1 unit.

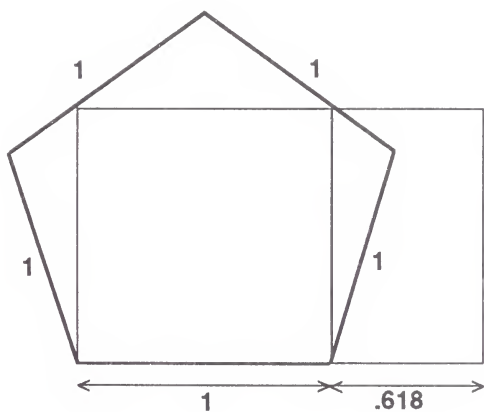
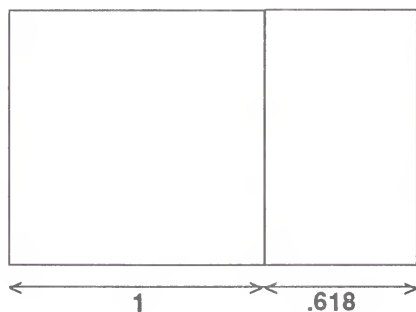
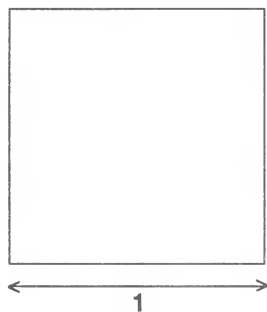

Now we have a pentagon with each side measuring 1 unit. The next step is to superscribe a circle around the pentagon. And finally, connect every other point on the pentagon, making a five-pointed star.

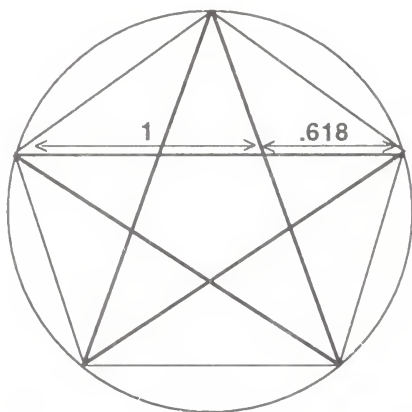
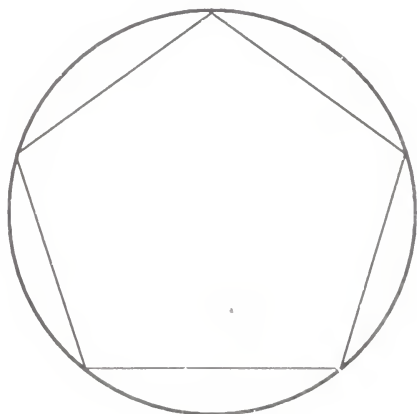

We have been working with the unit of 1. Let's give that unit a name. Let's call it a mile. One mile is 5,280 feet, or 63,360 inches. This would make the

perimeter of the pentagon 316,800 inches. It bears the number of the Lord Jesus Christ, 3168.

Using the mile for the unit, the perimeter of the original square would be 21,120 feet. It still bears His name.

2112 = A virgin shall conceive and bear a son and shall call his name Immanuel. (Isaiah 7:14)

If we were to draw a square on the height of the pentagon, it would still bear His name. The height is 1.53884 miles. Squaring this number gives us the square miles that it contains. It is 2.368 – the numeric value of Jesus Christ.

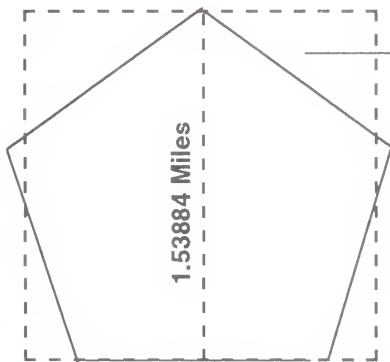

2.368 square miles

2368 = Jesus Christ

Ιησους Χριστος

These relationships are nothing that was invented by man. They are evidences of Divine design in the creation of man and man's home.

Realizing the beauty and harmony of the Golden

Proportion with all of creation, it pained me to realize that some claim the pentagram is Satan's symbol and that thus the Golden Proportion – .618 – is also Satan's number.

It cannot be denied that Satan has used this number. He has also used the five-pointed star, and placed it in inverse position. But he only takes this number by usurpation – it was not of his origin. Satan is the great counterfeiter. He has usurped other numbers that belong to the Lord Jesus Christ.

An example of Satan's use of the sacred numbers is the text of Revelation 13:18. It reads:

“Here is wisdom. Let him that hath understanding count the number of the beast; for it is the number of a man: and his number is six hundred threescore and six.”

Most everyone knows that the number 666 is the number of the beast, but not many realize that the number 666 originally belonged to Jesus Christ. The Antichrist, who is the counterfeit of Christ, usurps the number. He not only usurps the number 666, he also usurps the number 2368, which is the numeric value of Jesus Christ.

The Apostle Peter quoted a portion of Psalm 118 and applied it to Jesus Christ. He said:

“Wherefore also it is contained in the scripture (Old Testament), Behold I lay in Zion a

chief corner stone, elect, precious: and he that believeth on him shall not be confounded. Unto you therefore which believe, he is precious: but unto them which be disobedient, the stone which the builders disallowed, the same is made the head of the corner.” (I Peter 2:6-7)

Peter was quoting the words of Psalm 118:22 which read:

“The Stone which the builders rejected has become the Head of the corner. This is from Jehovah, it is marvelous in our eyes.”

It is clearly a prophecy concerning Jesus Christ. He is the Stone that the builders rejected. The numeric value of His title as “*Head of the corner*” is 666.

Jesus quoted this also, and clearly applied it to Himself:

“Jesus saith unto them, ‘Did ye never read in the scriptures, The stone which the builders rejected, the same is become the head of the corner: this is the Lord’s doing, and it is marvelous in our eyes?’” (Matthew 21:42)

The number 666 is the number given to Jesus as the chief cornerstone. He is the One on whom the whole structure of the plan of God for the salvation of man rests. He is the “*Head of the Corner,*” whose numeric value is 666.

Looking again at the scripture in Revelation 13:18 we also find the number 2368, which is the numeric value for Jesus Christ. The text reads:

“And his number is six hundred threescore and six.” (Revelation 13:18)

The numeric value of this phrase is 2368. It is not just a coincidence. It was planned to show the Antichrist for what he actually is – the counterfeit Messiah. In fact, it is not specifically the Antichrist who bears this number, but the whole “beast” system whom he heads.

This is not an isolated case. Satan repeatedly holds numbers that belong to Jesus Christ. Below are some of them:

358 = Messiah, משיח

358 = Serpent, נחש

364 = Anointed One, משיחו

364 = Satan, השטן

75 = The Son, ο υιος

75 = Lucifer, הילל

666 = Jehovah God that created the heavens,
האל יהוה בורא השמים, (Isaiah 42:5)

666 = Head of the Corner, לראש פנה

666 = Six hundred threescore and six, χξϛ

2368 = Jesus Christ, *Ιησους Χριστος*

2368 = And his number is six hundred threescore and six, *και ο αριθμος αυτου χξξ*

One of the beautiful evidences that the Golden Proportion is of Divine origin can be found in the blessing that Jacob bestowed on his son Judah. I would like to show this as it appears in the Masoretic Text. Its use of the Golden Proportion is magnificent! (Read from right to left)

שבט	לאיסור								
The	shall not	=	618						
sceptre	depart								
311	307								
מיהודה	ומחקה	מבין	רגליו						
from	the nor	from	his						
Judah	lawmaker	Judah	feet						
70	254	102	249						
עד	כייבא	שילה							
until	comes	Shiloh							
74	43	345							
ולו	יקהת	עמים							
and	the	the							
to	obedience	peoples							
him	of								
42	515	160							

$$\begin{aligned} 618 + .618 &= 1000 \\ 1236 + .618 &= 2000 \\ 1854 + .618 &= 3000 \\ 2472 + .618 &= 4000 \end{aligned}$$

When Jacob gave this blessing to Judah he said it would be fulfilled in the “*last days*.” The whole blessing reads:

“Judah is a lion’s whelp; my son, you have gone up from the prey; he stoops, he crouches like a lion; and like a lioness, who can rouse him up? The sceptre shall not depart from Judah, nor the lawmaker from between his feet, until Shiloh come, and the gathering of the people shall be to him. Binding his foal to the vine and his ass’s colt to the choice vine, he washes his clothing in wine, and his raiment in the blood of grapes. His eyes shall be dark from wine and his teeth white from milk.” (NIV)

This blessing, placed on the head of Judah, was actually a prophecy of the One who would come from the line of Judah in the “*last days*.”

Speaking of the time when this Lion of Judah would take His role as King; the prophet Zechariah said, “*The Lord shall be King over all the earth.*” It adds to 618, the Golden Proportion.

Malachi also spoke of that coming day, and he asked the question, “*Who can endure the day of His coming? Who can stand at His appearing?*” The Hebrew word for “*His appearing*” is *הָרָאָתוֹ*, and it has a numeric value of 618. Thus the Golden Proportion has a direct relationship to the time of the transfer of the right of rulership.

The ninth chapter of the book of Daniel contains a prophecy regarding the time of the coming of Messiah, and seven periods of time called “weeks.” The items relating to His return and the time of His rightful rulership are given in terms of the Golden Proportion.

The prophecy speaks of six things that were to be accomplished.

1. to finish transgression
2. to put an end to sin
3. to atone for wickedness
4. to bring in everlasting righteousness
5. to seal up vision and prophecy
6. to anoint the Most Holy

Notice that “*to seal up vision and prophecy*” has a numeric value of 618; and “*to anoint the Most Holy*” has a numeric value of twice 618, namely 1236.

There is no way that Satan can claim authorship of these numbers. They pertain to the time when man’s right of rulership has expired, and “*He comes whose right it is.*”

Seeing that the prophecy of Jacob, when he gave his blessing to Judah, pertains to the “*last days,*” and is structured on the Golden Proportion; and seeing that the prophecy of Daniel also pertains to the “*last*

days” and the time of the transfer of the right of rulership of earth, and this also is structured on the Golden Proportion, it gives us great cause for rejoicing. For it suggests a time sequence.

The Gematria of the blessing placed upon Judah is divided into sequences depicting 1000, and 3000. If it pertains to time (and it is a distinct possibility) then we might wonder if the 1,000 years pertains to the period of time from King David to the birth of Jesus; and the 3,000 years might perhaps pertain to the time from King David to King Messiah, when He becomes earth’s rightful ruler – the time when He takes the name of Shiloh, “*the peacemaker.*”

Appendix 4

The Great Pyramid

The Great Pyramid is the oldest wonder of the world, and the only one still in existence. The enormous size of that ancient structure is difficult to comprehend, even when standing at its base and traversing its magnificent mass with our eyes. Its base covers thirteen acres, and it contains enough masonry to build a sidewalk three inches thick and two feet wide that would reach around the world. Built of solid limestone throughout, except for its passages and chambers, clearly the Architect of the Great Pyramid wanted it to remain. And remain it has!

It was once covered with dazzling white polished limestone casing stones which reflected the light of the sun to great distances. It was, in fact, once called the "Pyramid of Light."

Its purpose has mystified historians and archaeologists for many centuries. Some have supposed it to be a tomb, however, nearly all historians will agree that no one was ever buried there. The secret of its purpose has remained a mystery until modern times, when accurate measurements were taken and it was found to be commensurate with the earth, our solar system, and, yes, with the Gematria of the Bible.

Isaiah wrote concerning this magnificent structure:

“In that day an altar to Jehovah shall be in the midst of the land of Egypt, and a pillar to Jehovah at its border. And it shall be for a sign and a witness to Jehovah of hosts in the land of Egypt.” (Isaiah 19:19-20)

By assigning the number equivalents to every Hebrew letter in this text, and adding them, we find the total to be 5449. The height of the Great Pyramid, from its socket level base to its summit platform, is 5449 Pyramid inches (nearly identical to the British inch). This remarkable identification of that ancient structure does not stand alone.

This height is a rounded figure. The true mathematical figure is 5448.96 Pyramid inches. The preciseness of this measurement produces some surprising figures.

As has been noted in this book, the name Jesus is spelled two different ways in the Greek text of the New Testament. One spelling has a Gematria of 888, and the other spelling has a Gematria of 688. This latter figure is used over and over again in the geometry of the Great Pyramid.

If we were to draw a square on the height it would not only reveal the name of Jesus, but additionally it would bear the number of the Lord Jesus Christ. It can not easily be passed off as random coincidence.

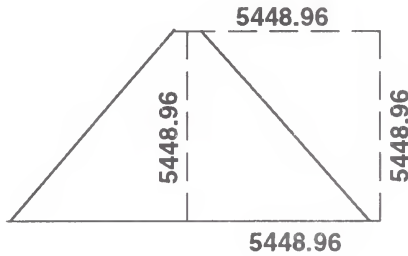

5,448.96 = Height of Great Pyramid to its summit platform
 21,795.84 = Perimeter of square drawn on height

Divide perimeter of square by Jesus (688) and the result will be 31.68, Lord Jesus Christ.

The height of the Great Pyramid is earth-commensurate by many mathematical processes. By drawing a circle on the height (height becomes the diameter of the circle), we obtain the name Jesus again.

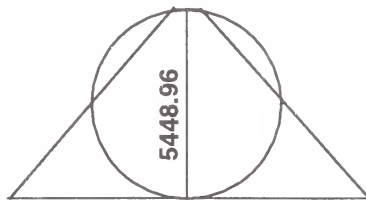

5,448.96 = Diameter of circle
 17,118.398 = Circumference of circle

Divide the circumference of circle by the circumference of earth

$$17,118.398 \div 24,881.392 = .688$$

688 = Jesus

The earth (man's place of dominion) turns on its axis roughly 365 times in one year. If we multiplied 365 by the circumference of the earth, it would tell us how many miles any given spot on earth travels through space in one year. It is giving us distance. If that is the distance for one year, then if we multiplied by 6,000 it would give us the distance that earth travels through space in 6,000 years. The math looks like this:¹

$$365 \times 24,881.392 \times 6,000 = 5449 \text{ (dropping the zeros)}$$

It is the same figure as the height of the Great Pyramid, and the Gematria of Isaiah 19:19-20 which is describing the Great Pyramid.

We find, then, that the height of that most ancient of structures, is commensurate with the 6,000-year plan for man. The time when man was granted the dominion.

By its passages and chambers, the Great Pyramid does, in fact, reveal the entire plan of God for the salvation of man through Jesus Christ. Many theories have been put forth regarding a time-line in the measurements of these passages and chambers, most of which have been proven inaccurate by the passing of the dates predicted. However, in 1940, author and

1 This marvelous equation was sent to me by Neil Pinter, of Borger, Texas.

researcher, David Davidson, suggested using a straight measure that follows the floor line of the two ascending passages. He projected this downward until it intersected with the projected angle of the outer casing stones, and projected it upward until it touched the Granite Leaf in the AnteChamber. This will measure exactly 6,000 Pyramid inches. The interim dates precisely fit the chronology of man.

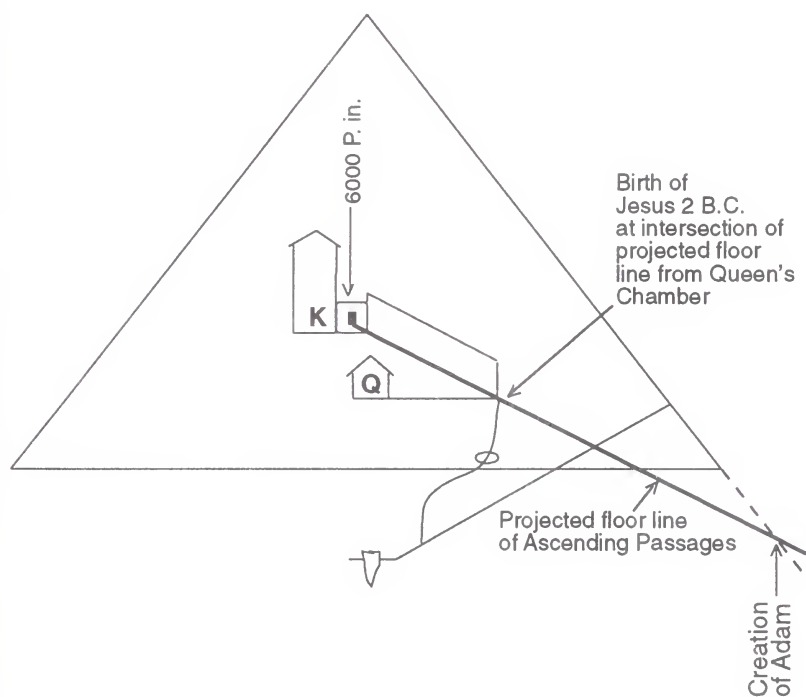

These are remarkable evidences! They suggest that the Great Pyramid, from its socket level base to its summit platform tells the whole story of the 6,000-year plan for man. And, as has been shown, the

topstone of this marvelous structure is Jesus Christ. After man's 6,000 year right of dominion, it is transferred to "*Him whose right it is.*"

"The Stone (topstone) which the builders rejected, has become the Head of the corner. This is from Jehovah, it is marvelous in our eyes." (Psalm 118:22-23)

The relationship of the topstone to the base perimeter of the Great Pyramid illustrates earth's orbit around the sun, which completes one cycle every 365.242 days. This is shown by the measure of its perimeter at the socket level, which is 36524.2 Pyramid inches. It is also shown by the Gematria. When the Apostle Peter referred to Jesus as the topstone (I Pet. 2:6), he used the Greek word *γωνια*, which has a numeric value of 864. How fitting, indeed, that the diameter of the sun is 864,000 miles.

The four corners of the Great Pyramid rest upon sockets that were sunk into the natural rock to an average depth of 9+ inches. The base perimeter, however, rests on a platform placed upon this bedrock. Thus, because of the angular sides, the perimeter at rock level will be slightly less than the perimeter at socket level. The measure around the base at rock level is 3041 feet. The number does not appear to be related to the number patterns in the Gematria of the Bible. However, when measuring this circuit of the rock level base by other units, the numbers do indeed fit the pattern.

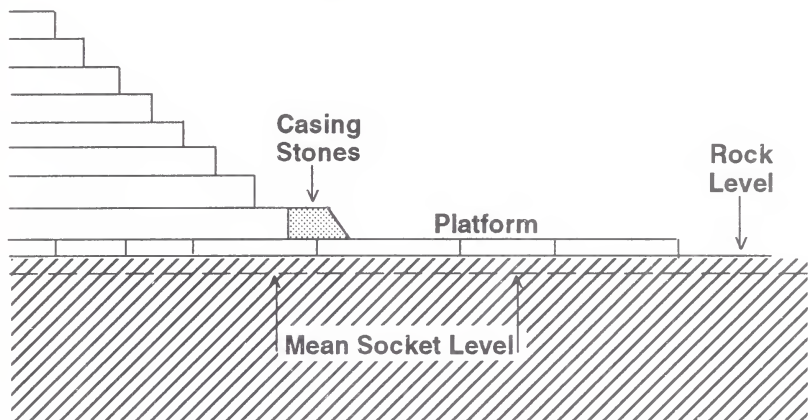

When the 3041 feet are converted to miles, the numbers become outstanding. One side of the Great Pyramid at rock level measures .144 of a mile. It is a number denoting that which is in God's realm.

Two sides would measure .288 of a mile. In the Gematria of the Bible, the title "*Kingdom of Heaven*" (Matthew 13:47) has a numeric value of 2880. It appears to represent those who will be a part of the heavenly aspect of that Kingdom – those who will be the Bride. Here are some other uses of the number.

2880 = The Bride, the Lamb's wife (Rev. 21:9)

2880 = The joy of the Lord (Matthew 25:21)

288 = Betrothed, חרף

288 = A holy calling (II Tim. 1:9)

The measure of three sides of the rock level base would be .432 of a mile. It is a number that appears to take in the whole world.

432 = All things, *παντα*

432 = Habitation, *κατοικια*

432 = The habitable world, *תבל*

432 = All nations, *כל-גוים*, (by multiplication)

And, finally, the complete measure around all four sides of the rock level base of the Great Pyramid is .576 of a mile. It relates to the Hebrew year 5760, which year marks the end of 6000 years from Adam. This rock level perimeter appears to be relating to the progressive plan of God for the salvation of man through the Lord Jesus Christ. This was built up into the complete structure that rests on this base, with Jesus Christ, as the topstone.

There is no evidence that the original topstone was ever lifted into place on this marvelous monument. As long as the dominion is in the hands of man, whether by right or by usurpation, there will be no topstone. I can only theorize that when Jesus sets up His Kingdom in Jerusalem, perhaps the original topstone will be brought forth from its hiding place, and placed at the top of the Great Pyramid.

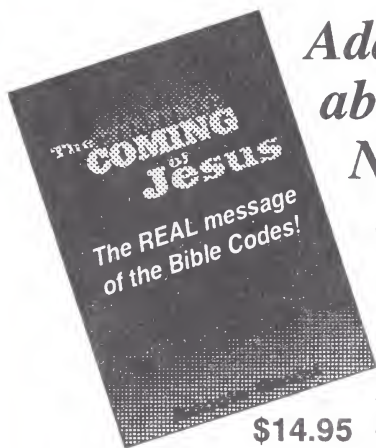

Additional books about the Gematria Number Code of the Bible!

THE COMING OF JESUS

The Real Message of the Bible Codes!
by Bonnie Gaunt

The Constellations of the heavens are a "code," telling the same story of the end-time as is found in the Number Code and the ELS Code of the Bible.

\$14.95

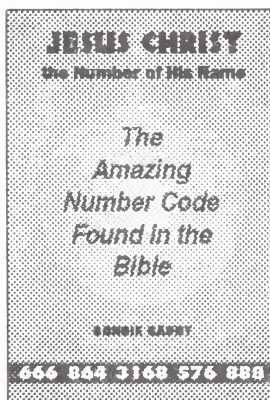

\$12.95

JESUS CHRIST the Number of His Name by Bonnie Gaunt

The Bible's Number Code tells of the new Millennium and the "Grand Octave of Time" for man. Reveals the amazing relationship of the Number Code to the ELS Code in the prophecies of the coming of Jesus. Explores the use of the Golden Proportion in the time features of God's plan for man.

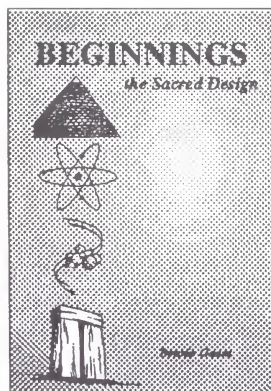

\$14.95

BEGINNINGS the Sacred Design by Bonnie Gaunt

The Bible's Number Code reveals an amazing design interwoven into all creation—a design of which we are a part. Explores the "what" "when" and "how" of the origins of man, our earth, our solar system, and our universe.

Adventures Unlimited, Inc., P.O. Box 74, Kempton, IL 60946

Tel: 815-253-6390 FAX: 815-253-6300

email: auphg@frontiernet.net

Books by Bonnie Gaunt

THE COMING OF JESUS

The Real Message of the Bible Codes!

\$14.95

JESUS CHRIST

The Number of His Name

\$12.95

BEGINNINGS

The Sacred Design

\$12.95

STONEHENGE AND THE GREAT PYRAMID

Window on the Universe

\$12.95

THE STONES CRY OUT

God's Best Kept Secrets Hidden in Stone

\$9.95

THE MAGNIFICENT NUMBERS

of the Great Pyramid and Stonehenge

\$9.95

STONEHENGE

a Closer Look

\$9.95

**All of the above books explore the exciting science of
Gematria, the Number Code of the Bible.**



3 9999 04058 660 2

WITHDRAWN

No longer part of the
Boston Public Library.
Sale of this material benefits the Library



\$14.95

The Number Code is not new. It was, however, largely lost sight of during the intervening centuries since the early church. In recent years the study of this ancient science, called Gematria, has proven to be an exciting aid to the study of the Bible. It gives evidence of the authenticity of the Creator, showing the awesome harmony between His Word and His works, and helps us to understand where we are on God's time-clock of the ages. We stand today on the threshold of the great Third Day which will usher in the Kingdom of Jesus Christ. This book is an exciting journey through that evidence.

The Author, Bonnie Gaunt, has written and published more on the Bible's Number Code than any modern author. She has appeared as a guest of Pat Robertson on the 700 Club, as well as on the television documentary, "The Mysterious Bible Codes." She has also appeared on the CBS 2-hour special "Ancient Mysteries of the World." Her work has received acclaim from many parts of the world.

ISBN 0-932813-83-6



9 780932 813831

ISBN 0-932813-83-6

Adventures Unlimited Press