

Relevance  
in  
Argumentation



Douglas Walton

TLFeBOOK

# **Relevance In Argumentation**

*This page intentionally left blank*

# **Relevance In Argumentation**

Douglas Walton  
*University of Winnipeg*



2004

LAWRENCE ERLBAUM ASSOCIATES, PUBLISHERS  
Mahwah, New Jersey London

TLFeBOOK



Camera ready copy for this book was provided by the author.

Copyright © 2004 by Lawrence Erlbaum Associates, Inc.

All rights reserved. No part of this book may be reproduced in any form, by photostat, microform, retrieval system, or any other means, without prior written permission of the publisher.

Lawrence Erlbaum Associates, Inc., Publishers  
10 Industrial Avenue  
Mahwah, New Jersey 07430

Cover design by Sean Sciarrone

**Library of Congress Cataloging-in-Publication Data**

Walton, Douglas

Relevance in argumentation / Douglas Walton.

p. cm.

Includes bibliographical references and index.

ISBN 0-8058-4759-6 (cloth : alk. paper)

ISBN 0-8058-4760-X (pbk. : alk. paper)

Logic. 2. Relevance. I. Title.

BC199.R44W35 2003

168—dc21

2003044099

CIP

Books published by Lawrence Erlbaum Associates are printed on acid-free paper, and their bindings are chosen for strength and durability.

Printed in the United States of America

10 9 8 7 6 5 4 3 2 1

*For Karen, with love*

*This page intentionally left blank*

# Table of Contents

Preface	xi
Acknowledgments	xv
<b>CHAPTER 1: EXAMPLES OF IRRELEVANT ARGUMENTS</b>	<b>1</b>
1. The Exclusionary Function	2
2. Irrelevance in a Political Debate	4
3. Murder is a Horrible Crime	8
4. Problems in Judging an Argument Irrelevant	10
5. Material Relevance	13
6. Other Fallacies of Irrelevance	15
7. Irrelevance in Legal Argumentation	17
8. The Straw Man Fallacy	21
9. Relevance as Relative to a Discussion	25
10. The Dialectical Nature of Relevance	28
<b>CHAPTER 2: HISTORICAL BACKGROUND</b>	<b>31</b>
1. Aristotle on Misconception of Refutation	32
2. The Ancient Concept of <i>Stasis</i>	35
3. Irrelevance and Digression	38
4. William of Sherwood on <i>Ignoratio Elenchi</i>	42
5. The Obligation Game	44
6. The Port Royal Logic	47
7. Isaac Watts's <i>Logick</i>	49
8. Whately's <i>Elements of Logic</i>	52
9. McCosh on Shifting Ground	55
10. The Perspective of Schiller and Sidgwick	57
<b>CHAPTER 3: TEXTBOOK TREATMENTS OF IRRELEVANCE</b>	<b>61</b>
1. Minimalistic Aristotelian Accounts	62
2. Problematic Cases	64
3. The Dual Approach	68
4. Damer: Further Subtleties of Relevance	71
5. Johnson and Blair: Irrelevant Reason and Red Herring	74
6. Govier: Probative Relevance	77
7. Hurley: Another Variant of the Dual Approach	80
8. Straw Man and Relevance	82
9. The Current Predicament	85

<b>CHAPTER 4: THE PROBLEM OF ANALYZING RELEVANCE</b>	<b>89</b>
1. The Paradoxes	90
2. Relevance and Conditionals	92
3. Relevance Logic and Formal Relevance Systems	95
4. Appeals to Emotion	100
5. Apparent Relevance	105
6. Pragmatic Conversational Failures	108
7. Conversational Implicature	111
8. Problems with the Gricean Approach	113
9. Argument Diagramming	115
10. Components of a Theory of Relevance	120
<b>CHAPTER 5: THE DIALECTICAL NATURE OF RELEVANCE</b>	<b>125</b>
1. Relevance in a Persuasion Dialogue	126
2. Relevance in Information-Seeking Dialogue	131
3. Other Types of Dialogue	135
4. Eristic Dialogue	139
5. Deliberation and Inquiry	141
6. Dialectical Shifts	147
7. Functional Embeddings	151
8. The Problem of Premise Availability	155
9. Functional Embedding and Relevance	158
10. Problems to be Solved	161
<b>CHAPTER 6: EVIDENCE AND METHODS FOR MAKING RELEVANCE JUDGMENTS</b>	<b>167</b>
1. The Target Concept of Relevance	168
2. Argument Chaining and Levels of Abstraction	172
3. The Method of Argument Extrapolation	177
4. Modeling Shifts, Embeddings and Fallacies	186
5. Analysis of the Currency Conversion Case	191
6. The Method of Profile Reconstruction	195
7. Outline of a Combined Method	198
8. Extensions of the New Theory	203
9. Limitations of the New Method	208
10. Irrelevance as a Procedural Charge	211
<b>CHAPTER 7: FALLACIES OF IRRELEVANCE</b>	<b>215</b>
1. The New Dialectical Theory of Fallacious Irrelevance	216
2. Evaluation of Cases Using the Two Theories	219
3. Insufficiency and Irrelevance	223
4. Enthymemes and Relevance	226
5. The Red Herring Fallacy	230

6.	Diversion and Pettifoggery	232
7.	The Separation Problem	235
8.	<i>Ad Hominem</i> Arguments and Irrelevance	237
9.	Irrelevance, Fallacies, and Shifts	238
10.	Summary of the New Theory	240
<b>CHAPTER 8: RELEVANCE IN LEGAL ARGUMENTATION AND POLITICAL DEBATE</b>		<b>247</b>
1.	Relevance Rules in the Canadian House of Commons	247
2.	The Problem of Relevance in Political Debate	251
3.	Relevance in Evidence Law	254
4.	Wigmore on Relevance	259
5.	Argument Diagramming in Evidence Law	264
6.	Legal Exclusion of Relevant Evidence	268
7.	The Natural System of Legal Relevance	272
8.	Probative Weight in Argument Diagramming	276
9.	The Trial as a Framework of Relevance	279
10.	The Critical Standpoint	284
<b>BIBLIOGRAPHY</b>		<b>289</b>
<b>AUTHOR INDEX</b>		<b>299</b>
<b>SUBJECT INDEX</b>		<b>303</b>

*This page intentionally left blank*

# Preface

The purpose of this book is to present a method that can be used to assist a user to critically evaluate arguments, and other moves in argumentation, for relevance. The aim is to enable a critic to judge whether a move can justifiably be said to be relevant or irrelevant. The method is based on case studies of argumentation in which a criticism has been made that an argument, or part of an argument, is irrelevant. The method is also based on a new theory of relevance that incorporates techniques of argumentation theory, logic and artificial intelligence.

One of the best entry points to studying relevance is through irrelevance, because objections on the basis of irrelevance in argumentation are, in some instances fairly clear and pointed, in specifying what is objectionable. The book begins by reviewing some ordinary examples, many of them taken from the textbook accounts of the traditional fallacies of irrelevance. By beginning with gaining some understanding of how the negative criticism “That’s irrelevant!” works in a context of argumentation, light is shed on the kind of evidence that is needed to support the claim that something is objectionable because it is irrelevant in an argument. The book uses these cases as a basis to move forward and develop the new theory of irrelevance and relevance. For example, a prosecuting attorney in a murder trial goes on and on arguing that murder is a horrible crime. His argument is criticized as irrelevant to proving the guilt of the accused party. A legislator, during a debate on a particular housing bill, launches into a long-winded argument for the proposition that all people deserve decent housing. His argument is said to be irrelevant in the debate on whether the bill at issue is a good piece of legislation or not. These are typical of the kinds of cases cited as instances of fallacious irrelevance by the logic textbooks.

Chapter 2 is a historical study of the development of the concept of relevance in argumentation starting with its roots in Greek logic and rhetoric. The idea of the fallacy of irrelevance has been incorporated into teaching manuals on logic since the time of Aristotle. There has been one central fallacy, and various related fallacies of irrelevance. Beginning with Aristotle’s account of the central fallacy of *ignoratio elenchi* (misconception of refutation), the idea of irrelevance as a logical fault is traced through the middle ages and into the early modern period. But the most important source of material on how relevance is part of argumentation comes from Greek rhetorical manuals.

Chapter 3 presents a survey of the treatments of the main fallacies of irrelevance in the modern logic textbooks, from 1878 to 1995. The leading treatments are selected, summarized and commented on. A main focus of interest here is the examples they used to illustrate fallacies of irrelevance. The idea is to get a practical grasp of relevance by studying textbook examples,



useful in formulating and testing out the new theory of relevance developed in chapters 4 and 5. The central part of the book is chapter 6, where a practical method of judging relevance and irrelevance in argumentation is presented. The method can be applied to cases to give objective evaluations of criticisms of irrelevance, based on the evidence furnished by the case. In chapter 7, the different specific kinds of fallacies of irrelevance are classified into species and subspecies. Once these faults are pinpointed, and their practical importance made clear, a way of dealing with fallacies of irrelevance is recommended.

Chapter 8 deals with relevance judgments in two special contexts of argumentation, political debate and evidence law. The theory is developed so that it can successfully apply to these contexts, even though procedural rules specific to an institution need to be taken into account. In the legal example cited above as a common textbook case, the prosecuting attorney's argument was put forward in a court of law. So to really understand the basis of ruling on relevance in a case of this sort, procedural rules in the law of evidence would have to be taken into account. In the Anglo-American law of evidence, relevance is a fundamental concept on which the rules of evidence are based. And similarly, there are procedural questions in dealing with the legislator's argument about housing. In a legislature, there are rules of debate. The moderator of the debate, or "Speaker", may invoke rules of relevance to declare the legislator's digression "irrelevant". From a logical point of view, it could be said that the general tactic used is that of red herring or diversion. But such a logical judgment clearly depends on an institutional context in which there may be definite procedural rules governing relevance. These legal and debate cases are so contextually rich that they seem almost beyond the bounds of what can be encompassed by any logical theory of relevance. But still, in chapter 8 it is shown that the new theory of relevance can throw some light on argumentation in them from a critical standpoint.

Cases are shown in the book to raise fundamental questions of relevance and irrelevance that have never before been answered. How can relevance be clearly defined in a sense required to support or refute the claims that arguments are defective because they are irrelevant? How can the supposed defect in arguments that commit the so-called "red herring fallacy" be identified, analyzed and evaluated in particular cases? And how could it be proved, or reasonably judged on the basis of objective evidence, that these arguments are irrelevant? The history of the subject of relevance chronicled in the book shows that previous attempts to answer these questions have not been successful. The book presents a clear account of the technical problems in the previous attempts to define relevance, including an analysis of formal systems of relevance logic, and an explanation of the Gricean notion of conversational relevance.

The theory of relevance offered in the book is meant to be a logical theory. It is meant to resolve outstanding problems in logic, like the vague, conflicting and unconvincing accounts of fallacies of relevance one finds in the

current logic textbooks. But it is logical in a broader or more applied and practical meaning of the term. In a word, the aim of the new theory is dialectical. This word means that the theory looks at relevance in a framework in which two parties take turns making moves in an orderly goal-directed conversation. Because of its dialectical structure, the theory also has power as a normative model that can help to analyze and evaluate real cases of natural language argumentation. The theory is designed to apply to a natural language chunk of discourse in which some judgment of relevance has been or could be made. For this reason, the theory has empirical uses. It also has rhetorical uses, because it examines sequences of argumentation used by one party in a dialogue with the aim of persuading another party. Because of its structure, the theory is also amenable to modeling by current methods of automating reasoning used in artificial intelligence. It is also a theory that can be applied to teaching, for example, by helping students to invent relevant arguments to support a thesis in an essay or composition, and to critique irrelevant arguments.

Thus readers in many fields will use the techniques developed in the book for their various purposes. But to grasp the central thrust of the new theory of relevance and irrelevance developed in the book, one has to realize that it is meant to be contribution to the field called dialectic, an old field that goes back to Platonic and Aristotelian roots, but that was quiescent for a long time until it was revived by Hamblin (1970). A dialectical theory views an argument as used in a verbal exchange in which two parties attempt to reason together for some common purpose. Something is properly judged to be irrelevant, according to the new dialectical theory, if it delays or interferes with the progress of dialogue, instead of contributing to its movement forward towards its goal. Thus the new dialectical approach is a development of Grice's pragmatic project of judging irrelevance as a failure to contribute to a collaborative conversational exchange. Grice did not try to define relevance or irrelevance however. By doing so, this project takes a next very important step forward. In the new theory, it is made clear how the objection of irrelevance is used as a kind of threshold or gatekeeping device to keep time-wasting useless speech from delaying a purposeful conversation.

The new dialectical theory of relevance has striking implications for a broad variety of important fields, like multi-agent systems in computing, rhetoric, and pragmatics in linguistics. The implications for debate theory and for evidence law are also quite striking and fundamental. The Federal Rules of Evidence, based on Wigmore's conception of legal evidence, has relevance as its central concept. Relevance is central to understanding the core structure of rules of argumentation in Anglo-American law of evidence. Another field much affected by relevance is library science, where this concept plays a key role in how information is organized and searched. All fields that have to do with thinking, like cognitive science, informal logic and argumentation theory, are areas where relevance is of central importance. For these fields, relevance is a

kind of Holy Grail. It is something that has not been clearly modeled in a useful way yet, but once it is, the impact on all these fields will be fundamental and sweeping. The new theory of relevance provides just the right sort of dialectical structure for modeling relevance that it is useful for analyzing and evaluating argumentation in all these fields, and for dealing with fallacies of irrelevance.

## Acknowledgments

The research that culminated in this book began many years ago. I had undertaken an analysis of relevance in argumentation some time ago (Walton, *Top. Rel.*, 1982), but I was unsatisfied by the largely negative outcome of this research. Its positive results could certainly not be described as a systematic theory of relevance, and the negative results concluded that formal semantic methods of logic were of limited usefulness in yielding a concept of relevance applicable to cases of argumentation in everyday discourse. Relevance remained a central problem, perhaps the central problem for argumentation theory, especially as applied to evaluating fallacies and critical faults of arguments.

In 1990, a collaborative research project with Frans van Eemeren and Rob Grootendorst was started at the Netherlands Institute for Advanced Study (NIAS) with the object of investigating the possibility of developing a pragmatic theory of relevance, as applied to arguments. This project got to the stage of resulting in some very promising discussions among the three of us, enabling us to draw up some outlines for research. Unfortunately, however, it never got beyond this beginning point, due to administrative burdens and interruptions posed by other projects that had more immediate deadlines. Eventually it became apparent that no progress had been made for several years. Meantime, academics and practitioners in many fields who had heard about the project kept contacting me, to ask for help on matters of relevance related to their research or practical concerns. Very graciously, Frans and Rob gave me permission to go ahead and attempt to do something on relevance myself. After some years, this project has finally come to fruition in the present book. Although the book expresses my own views, and represents my own line of thinking on the problem of relevance, the pragma-dialectical orientation of the Amsterdam School will be clearly evident to the reader. The beneficial effects of my association with members of that School show clearly in the many references to their works and views.

Another very helpful discussion forum that has shaped my views on relevance was the conference 'Relevance in Argumentation,' held in June, 1991, at McMaster University. Among the participants with whom I discussed the problem of relevance at the conference I would especially like to thank Frans van Eemeren and Rob Grootendorst again, Scott Jacobs and Sally Jackson, Chris Tindale, John Woods, Tony Blair, Jim Freeman, David Hitchcock and Erik Krabbe. For support in the form of a Research Grant in 1994-1997, and another one in 1999, I would like to thank the Social Sciences and Humanities

Research Council of Canada. I would also like to thank the Canada-U.S. Fulbright Foundation for a Senior Fulbright Fellowship in 1999, and the Department of Communication Studies of Northwestern University for hosting me as Visiting Professor during that period. While I was at Northwestern, discussions with Jean Goodwin and Michael Leff were instrumental in refining many of my views on relevance. I would especially like to thank Jean Goodwin for drawing my attention to important (and relevant) material on the history of legal disputes about relevance. Discussions on the problem of functional embeddings with Chris Reed in June, 1999 were also very helpful, as well as some assistance with *Araucaria* diagrams.

I learned a lot about new developments in computing that were vital to my analysis of relevance at the Symposium on Argument and Computation at Bonskeid House in Pethshire, Scotland, in June and July of 2000. I would especially like to thank Tim Norman and Chris Reed for organizing the conference, and for what they taught me during the tutorials and discussions at the conference. The following conference participants also deserve thanks for informing me about the state of the art of AI and clarifying many questions related to abduction: Trevor Bench-Capon, Daniela Carbogim, Jim Crosswhite, Aspasia Daskalopulu, John Fox, Jim Freeman, Janne Maaik Gerlofs, Michael Gilbert, Rod Girle, Floriana Grasso, Leo Groarke, Corin Gurr, David Hitchcock, Hanns Hohmann, Erik Krabbe, Peter McBurney, Henry Prakken, Theodore Scaltsas, Simone Stumpf and Bart Verheij.

For help with translating some passages of Aristotle, I would like to thank Craig Cooper. In the spring term of 2001, I was Visiting Professor in the Communication Department at the University of Arizona. During that period I learned more about legal argumentation, and was able to make an improved draft of the manuscript when I returned to Winnipeg in the summer of 2001. Michael Dues, Sally Jackson, Scott Jacobs and John Pollock helped my research efforts by discussing various subjects during the Arizona period. Discussions with Hans Hansen and Chris Reed during this period also turned out to be helpful.

I would like to thank the editors of *Argumentation* for permission to reprint some parts of my article, 'Which of the Fallacies are Fallacies of Relevance?' *Argumentation*, 6, 1992, 237-250, appearing in revised form as sections 5, 6 and 7 of chapter 1. The material in chapter 5, section 8 was originally published as 'Commentary on Reed' in *Argumentation at the Century's Turn*, CD-Rom., ed. Christopher W. Tindale, Hans V. Hansen and Sacha Raposo. St. Catherines, Ontario Society for the Study of Argumentation. My thanks to the editors for their permission to reprint this material. My special thanks to Amy Merrett for processing the text and figures of the manuscript. As well, I would like to thank Harry Simpson and Bill Dray for help with proof-reading.

## Examples of Irrelevant Arguments

To begin to investigate the concept of relevance, one should examine how it is used, or how it is useful, in everyday argumentation. What function does relevance have as a tool to help promote goals of rational argumentation? This question initially appears to be vague and abstract and, therefore, hard to answer. One can make it more specific by concentrating on the negative side of it, posing it in a different way as follows. What function does the objection “That’s irrelevant” have in argumentation? This question is easier to answer because one can focus on specific kinds of criticisms that are found in common examples and are fairly concrete. This negative way of putting the question in terms of irrelevance immediately links it to common examples of argumentation where irrelevance has been perceived to be a problem and where steps have been taken to solve the problem. Examination of these practices can give insight into why irrelevance is a problem in argumentation and what means have been devised to attempt to deal with it. Chapter 1 introduces the reader to some classic examples of this sort.

An important source of examples is the traditional part of logic concerned with informal fallacies. Irrelevance itself has often been categorized as a fallacy. But other fallacies have also been traditionally recognized that focus on certain specific kinds of problematic and fallacious irrelevance. The logic textbooks are full of examples of such arguments that offer clues on why irrelevance should be taken to be problematic in rational argumentation. Whereas a detailed survey of the textbook accounts is given in chapter 2, a few classic examples of irrelevant arguments from those accounts are presented in chapter 1 to help the reader grasp how the tradition of fallacies is important for understanding irrelevance as an objection.

One type of example often cited in the textbooks illustrates irrelevance in legal argumentation. In court, a lawyer arguing for one side in a trial can often be observed to object to an argument, question, or other move made by the lawyer for the other side by saying, “That’s irrelevant.” Irrelevance is taken to be a serious matter in court, and rules of evidence are very carefully devised to exclude or remove any argument or question deemed to be irrelevant.

Another type of example often cited occurs in political argumentation. The rules governing irrelevance in political debates tend to be looser, less precise, and less strictly enforced than those in legal argumentation. But such rules do exist in parliamentary and legislative debates, and the objection “That’s irrelevant” has some force in them.

Still another source is the history of rhetoric. Ancient Greek rhetorical writers were particularly concerned with irrelevant emotional appeals, for example those used in legal or political arguments that could sway an audience or a jury. Examination of these historical sources can cast light on relevance and irrelevance in argumentation, but aside from brief mention in chapter 1, historical matters will be treated in the integrated survey of chapter 2.

## 1. THE EXCLUSIONARY FUNCTION

The main function of the concept of relevance, as used in debates, discussions, and meetings, is to keep the discussion within productive boundaries. Used for this purpose, relevance fulfills what can be called a gatekeeping or exclusionary function in argumentation. Using the criticism “That’s irrelevant!” is a way of keeping the argumentation from straying off into less productive lines of reasoning that would not contribute to the resolution of the problem or conflict of opinions posed in the discussion. The problem in many such cases is that time for the meeting may be limited, and yet the problem to be solved may be urgent. In other cases, having a lengthy debate may be very costly. Hence, in order to solve the problem within the given constraints of time and money, it may be useful, or even necessary, to draw boundaries of relevance.

A good case in point is the example in Walton (*Inf. Log.*, 1989, p. 71) where a meeting of a university library committee has the issue on its agenda of whether library hours should be extended on Sundays. The Student Association has made a proposal to extend them on Sundays from eight hours to ten hours. Part of the dialogue in the meeting runs as follows:

- Case 1.1:* **Harry:** Not only should the library remain open longer so that students can have a place to study, but student tuition fees should be lowered as well.
- Pam:** Hold on, Harry. The topic of this meeting is the proposal for the extension of library hours. What does the topic of tuition fees have to do with it? I don’t see the relevance of that issue.
- Harry:** Well, if students didn’t have to pay so much tuition, they could afford better lodging, and therefore better facilities to study at home. I mean it’s all connected because many factors are responsible for not providing students with adequate facilities for studying. Therefore my point is relevant.

The problem in this case is to decide whether Harry’s argument is relevant or whether Pam’s objection to it on grounds of its irrelevance is reasonable.

The first thing to be noted in this case is that Harry's line of argument is at least potentially relevant. As his reply shows, there is a legitimate connection between the question of student tuition fees and the issue of library hours. But is it the kind of connection that justifies the claim that Harry's argument on tuition fees is relevant to, and ought to be included in the discussion in the library committee meeting? In an actual case, this is the question that would have to be determined by the chairman of the library committee or whoever is chairing the meeting of the committee that day.

The practical problem confronted by whoever is chairing the meeting is that the issue of how long the library should be open on Sundays needs to get a proper hearing so that all concerned parties can express their views. But the time that can be given for this purpose may be fixed. It is important, before a vote is taken, that the participants in the meeting should take all the relevant considerations into account if the discussion is to provide a good basis for deliberation on the issue. If the discussion gets sidetracked and spends too much time on one narrow side issue, then other, perhaps even more important considerations, may not be taken into account. If so, too much discussion on one limited side issue may block off the possibility of taking time to discuss main issues. This blocking-off effect may mean that the purpose of the discussion fails to be fulfilled.

The ultimate instance of this blocking-off effect is the use of the tactic called the filibuster in debate. For example, in a congressional or parliamentary debate, one participant may read from the Bible, or any book available, simply to fill enough time to prevent the other side from taking their turn. This tactic can be used to block debate on a bill, for all intents and purposes, by preventing the opposition from saying anything at all. In such a case, we can clearly see how the real purpose of the dialogue is blocked by this tactic of irrelevance. The reading of the Bible, or whatever document is used, contributes nothing to the argumentation in the discussion of the bill at issue. Its only function is to block out any arguments that might be used by the other side. The tactic is similar to the case of a football team that is not trying to score a goal, but simply to hang on to the ball long enough to maintain their lead until the few minutes left in the game have elapsed.

But it is a problem, at the initial stages of a dialogue, that it is difficult to tell which directions the argumentation may take in the subsequent discussion that will be productive. When the objection "That's irrelevant!" is made, a participant may reply, "If you will take my word for it, you will see later how this point will become relevant in the line of argument I will develop." So one who uses this criticism of irrelevance may also have to show some latitude and judgment in exercising the exclusionary function. The chairman will have to evaluate how well the discussion has succeeded at the particular point reached when Harry's argument was introduced, and judge how further discussion of



this issue will contribute to or block the argumentation needed to resolve the problem of extending library hours on Sundays.

## 2. IRRELEVANCE IN A POLITICAL DEBATE

Copi's textbook, *Introduction to Logic*, has now gone through eleven editions, and was the most popular introductory logic textbook in the western world (and perhaps in the whole world) for the first forty years or so it was in print. Copi treated irrelevance in argument under the heading of fallacies, as many logic textbooks have done. Copi (1968) divided fallacies into two broad categories: fallacies of relevance (a total of ten) and fallacies of ambiguity. Among the various fallacies of relevance (Copi, p. 72), the fallacy of *ignoratio elenchi* (*irrelevant conclusion*) is said to be "committed when an argument purporting to establish a particular conclusion is directed to proving a different conclusion." The case cited here is from the third edition (1968), but it is very close to that of the first edition (1953) and similar in outline to that of the ninth edition (co-authored with Carl Cohen, 1994):

*Case 1.2:* For example, when a particular proposal for housing legislation is under consideration, a legislator may rise to speak in favor of the bill and argue only that decent housing for all the people is desirable. His remarks are then logically irrelevant to the point at issue, for the question concerns the particular measure at hand. Presumably everyone agrees that decent housing for all the people is desirable (even those will pretend to agree who do not really think so). The question is: will this particular measure provide it, and if so, will it provide it better than any practical alternative? The speaker's argument is fallacious, for it commits the fallacy of *ignoratio elenchi*, or irrelevant conclusion (p. 72).

Copi's commentary provided a readily understandable version of the *ignoratio elenchi* fallacy for modern readers by explaining it as a failure to present evidence of the kind needed in a debate. As Copi explained it (p. 72), the fallacy is committed by the legislator's argument because it has failed to meet the requirement of providing evidence "capable of establishing the truth of the conclusion" to be proved (p. 72). The reason the argument in this case is said to be a fallacy of *ignoratio elenchi* is that the legislator should be confining his arguments to matters that are relevant to the specific housing bill under consideration in the debate. Instead, he argues in a rhetorically rousing manner for the proposition, 'All people should have decent housing.' But this general proposition is something that everyone accepts. Nobody in the debate, on either side, disputes it. Proving or disproving it is not relevant to settling the issue of

the debate—namely the particular housing bill being considered. Hence, the senator's rousing rhetoric is dismissed (Copi, 1968, p. 72) as a fallacious *ignoratio elenchi*.

One problem with this analysis is that the legislator's proposition, 'All people deserve decent housing' is relevant to the housing bill under consideration in a clearly definable sense. Both propositions are about housing. There is some subject-matter overlap between the two propositions. One is topically related to the other. Hence, the senator's argument for the proposition 'All people deserve decent housing' is relevant, in one sense, to the issue of the particular housing bill being debated. But if it is relevant, how can we say that a fallacy of *ignoratio elenchi*, or failure of relevance, has occurred? This apparent contradiction is a problem for the traditional textbook treatment of the *ignoratio elenchi* as a fallacy. One step toward a solution to this problem is to invoke a distinction between topical and material relevance. The first step in approaching the problem is to concede that the senator's proposition, 'All people deserve decent housing' is topically relevant to the issue of the debate on the housing bill. However, as indicated above, it does not seem to be materially relevant. But even taking this step presents another problem. The senator's argument could be more than just topically relevant. It could also be relevant to the issue of the housing bill, in the sense that, potentially, it could be part of some sort of argument, yet unidentified, that could be used as part of a sequence of argumentation to give evidence to support the bill being debated. We could say that it is potentially relevant evidentially, as well as topically, to the issue under consideration. In this sense, it could be relevant, depending on the details of the case the senator might be trying to make. At least it might be premature to declare that his argument is irrelevant.

But is potential relevance enough, in this case, for us to conclude that the senator has not committed a fallacious *ignoratio elenchi*? Perhaps not, if the distinction between potential and material relevance can be clarified. The senator's rhetorical flourish may be potentially relevant. But is it materially relevant? In other words, is it relevant in a sense that makes it a really useful contribution to the debate the participants are supposed to be engaged in? It can be argued that it is not, because it is not materially relevant to the resolution of the dispute on the housing bill. Let's say that the debate on the housing bill is limited to a certain time in the Senate. The purpose of the debate is to bring reasonable arguments to bear that might swing a significant number of the senators one way or the other. By looking at the arguments on both sides, a senator can come to a reasoned decision to vote for or against the particular bill being debated. This bill could be any specific bill—let us say it is about government subsidies proposed to help first-time house buyers to finance their mortgages. The two sides in the Senate might be locked in disagreement on whether to vote for this bill or not. Let's say, for example, that they disagree about the costs of the proposed legislation, whether its benefits outweigh its

costs, what its consequences are likely to be, whom it will really benefit, and so forth. An argument is materially relevant in the context of this debate on this particular bill if and only if it will bear strongly enough on one or more of these arguments so that it may shift the balance of considerations in the vote one way or the other. Otherwise it is not materially relevant in this particular context. It is on this basis, then, that the senator's argument for the proposition, 'All people deserve decent housing' could be rejected as not materially relevant. The failure of material relevance is a failure to be a strong enough argument to significantly influence the argumentation in the dialogue one way or the other.

This case shows a number of interesting things about irrelevance. One is that it is considered a fallacy by logic textbooks. Another is that irrelevance occurs in political arguments like legislative debates and can be an important problem in them. Another is that the problem apparently relates to the exclusionary function described in the previous section. If an arguer goes on and on with irrelevant arguments, the danger is that it could prevent relevant arguments from being heard, thus defeating the purpose of the debate.

Another thing shown by this case is the difficulty of dealing with irrelevance. The Speaker of the Senate is supposed to prevent this kind of problematic rhetorical digression from ruining a debate. But it may not be easy to do that in some cases. For, as we have seen, several different kinds of relevance are involved. The senator can argue that even though his argument is not relevant in one sense, it may still be relevant in another. There are rules of relevance for specific kinds of political debates, as will be shown in the next chapter. But if it is even difficult to define relevance, or to distinguish between different kinds of relevance, it may be difficult to identify irrelevance clearly and definitively in a given case.

Finally, there is one more lesson to be drawn from this case. It suggests a danger of irrelevance in argumentation, over and above the problem posed by the exclusionary function. This danger is that the senator might give such a crowd-pleasing speech on how all the people deserve decent housing that a majority of the senators are persuaded to vote for the bill. The danger is that the crowd-pleasing argument, even though it is materially irrelevant, might be psychologically successful in persuading the senators to go along with it. According to Copi's analysis of the fallacy in case 1.2, the speaker tries to evoke an attitude of approval for himself so this attitude can be transferred to his conclusion by "psychological association." But it is not logically relevant because he has not proved that the bill is in the public interest (p. 72). It is not logically relevant, in Copi's sense, because (as things stand, in the case) it is incapable of establishing the truth of the conclusion. The danger is associated with what some might call the prejudicial power of the argument. The argument could appear to be relevant to an uncritical audience, even though it is not, in some sense, logically or materially relevant.

This argument is an example of a political debate. In this case, a legislator argued that decent housing for all people is desirable. Copi judged the argument to be fallacious because it fails to establish the conclusion that the particular bill being debated will provide better housing for the people. But is this failure enough to warrant the evaluation that the legislator's argument is irrelevant? Could it be that the legislator may be moving toward making a connection in his speech between decent housing for all people and how the particular measure being debated will provide it? Shouldn't the legislator be given enough time to make this connection and show his argument is relevant?

The answer to this question depends on certain factors relating to the forum of the political debate on the housing legislation. We are told very little about this—about whether it was a Senate debate of a particular kind, subject to certain procedural rules of relevance or not, and so forth. We are not told what stage the debate had reached. About all that can be presumed is that it was a legislative debate on a particular proposal on housing. Presumably then, the debate on this bill was put forward in some political assembly, and it would have been subject to rules of debate and moderated by a Speaker. Presumably also, because the debate was on a specific piece of legislation, a Speaker would limit time for debate. Not too much wide-ranging broad discussion of issues not directly bearing on the legislation in question would be permitted.

Once this context of the debate format is filled in, it is not too hard to see why the legislator's bringing in of arguments about decent housing for all the people could be ruled irrelevant, say by the Speaker. For arguments about decent housing for all the people are not likely to have much direct influence in changing anyone's vote in the Senate on a particular housing bill being considered. So by hastily sketching in all these background particulars of the setting of the political debate, we can grasp and appreciate in general outline why Copi would classify the argument in case 1.2 as an instance of the *ignoratio elenchi* fallacy. We can see why he evaluates the argument as an irrelevant appeal. The problem is that the example is so brief. Many background particulars of the institutional setting of the argument have to be filled in, by presumption or conjecture, to give enough information to yield the basis for even a conditional evaluation of irrelevance, and a tentative one at that. What would happen if such a sketchy notion of relevance was applied to, say, cases of political debate where a more extensive and detailed account is given, both of the text of discourse of the case and of its institutional and social setting? Could such a case be properly evaluated for irrelevance of arguments from a logical and critical point of view of the kind that has generally been attempted by the logic textbooks, even though institutional rules of relevance might be applicable to the case?

One persistent and central problem in attempting to evaluate relevance of arguments used in legal trials and political debates is that judgments of relevance in these contexts are bound by specific rules that are localized to juris-

diction or setting. There are legal rules of relevance applicable to a trial, and there are rules of relevance in handbooks that give rules governing political debate in an assembly. Hence, this question is posed: What right do we have as critics, who are, say, participants in a class or research group in logic or critical thinking—who are in fact not lawyers or elected office-holders—to criticize and judge such legal or political arguments as relevant or irrelevant? The idea that critical thinking is specific to a discipline has been advocated by McPeck (1981), and there seems to be something to be said for this idea. Much the same sort of limitation could be stated regarding arguments in a political debate or legal trial, where rules of procedure are applied by a Speaker or judge. Hence, it seems to follow that we, as critics, have really no right or basis in logic to judge an argument in a legal trial or a political debate as irrelevant from our own externalized and abstracted viewpoint.

On the other hand, if we take this discipline-bound (or institution-bound) point of view on judging relevance seriously, it follows that we, as citizens or observers, have no right or justifiable basis for criticizing the shortcomings of legal or political arguments from a logical point of view. But this restrictive view seems extreme, even absurd, in a democratic political system where a citizen is supposed to make reasoned judgments of political and legal arguments and use critical thinking to decide how to vote or which policies and arguments to support. This sort of use of logical thinking to weigh the arguments is precisely the function of a jury, and it is certainly an important ingredient in the justification of democracy as a political system. It is intelligent and independent critical thinking and evaluation of arguments that are supposed to make the system work. Consequently, a dilemma is posed, and it appears to require the opening up of a middle way between these two extreme positions. On the one hand, we should feel free to make critical comments on relevance, and other critical matters of a logical sort, in evaluating political and legal arguments. But on the other hand, we need to be careful and circumspect in making such judgments and realize that they are conditional on certain factors that are particular to an institutional setting.

### **3. MURDER IS A HORRIBLE CRIME**

The prejudicial power of the irrelevant argument has appeared to be even more dangerous in legal argumentation than it is in political argumentation. Anglo-American law has seen it this way, at any rate. For it is a notable fact of evidence law that irrelevance has become quite carefully excluded by the rules of evidence. One of the main rationales for these exclusions is the worry that irrelevant arguments might tend to prejudice the jury. Chapter 8 will explain these rules and show how they are used in trials to try keep irrelevant arguments out. However, to introduce the reader to how irrelevant arguments can arise in a

trial, and be significant in persuading a jury, it is best to begin with a simple but typical case. Once again the classic case is found in Copi (1968, p. 72), as well as in many other logic textbooks:

*Case 1.3:* In a law court, in attempting to prove that the accused is guilty of murder, the prosecution may argue at length that murder is a horrible crime. He may even succeed in proving that conclusion. But when he infers from his remarks about the horribleness of murder that the defendant is guilty of it, he is committing the fallacy of *ignoratio elenchi* (p. 72).

Much the same kind of analysis of the prejudicial power of the irrelevant argument of case 1.2 is applied by Copi (p. 73) to case 1.3:

If the prosecution has given a sufficiently moving picture of the horribleness of murder, the jury may be so aroused, such horror and disapproval may be evoked in them, that they will bring in a verdict of guilty more swiftly than if the prosecutor had “merely” proved that the defendant had committed the crime.

One can see Copi’s point, but there are some complications involved in evaluating this kind of case. If the prosecutor is describing the horribleness of murder, perhaps it is because he is trying to show that not many people would be able to carry out such a horrible crime. If the defendant is a particularly aggressive or ruthless person, as the jury has been shown, then the conclusion the prosecutor could be trying to get the jury to infer is that this defendant, unlike many other people, would be capable of carrying out the crime of murder. If so, the prosecutor’s premise that murder is a particularly horrible crime would be logically relevant, in Copi’s sense, to the conclusion that the defendant is, or may be, guilty of the crime he was charged with.

Of course, in a real case of this sort, the judge would have to rule on whether the prosecutor’s argument was relevant or not. The judge has the obligation to stop the prosecutor’s line of argument if he seems to be getting off track with regard to fulfilling his burden of proof. As noted, this task would require some judgment and some grasp of where the prosecutor’s argument seemed to be going. If the defending attorney charged that the prosecutor’s argument was not relevant, the judge would have to make a ruling one way or the other. But if the prosecutor asked the judge for a little time to show how his argument about the horribleness of murder was relevant, the judge might grant this request or might not.

In fact, there are rules of relevance that are applicable to court cases. Certain kinds of arguments—those that might tend to bias the jury, for example—are ruled irrelevant, depending on the kind of trial in progress and the

rules applicable in different legal systems and jurisdictions. Legal rules of relevance are outlined in chapter 8. To sketch out how relevance is defined in evidence law, the following account may be helpful. According to Choo (1993, p. 115) an item of evidence is legally relevant where it has *probative value*, meaning that it renders a fact in issue more probable than it would be without this evidence. But legal relevance is not just based on probative value. To be considered legally relevant in a trial, an argument must have enough probative value to outweigh such possible contravening considerations as “prejudice to the defendant, the introduction of collateral issues, delay, confusion of the jury, and so on” (Choo, 1993, p. 116). Even this initial exposure to legal rules of evidence on relevance indicates that legal relevance and logical relevance are not the same. A judge has to decide what is relevant or irrelevant in a trial, based at least partly on the trial rules.

Thus, evaluating case 1.3 introduces the special problem posed by the fact that the context of this case is that of a trial, meaning that relevance will need to be judged in relation to legal rules of procedure and evidence, as applicable to the case in point. This problem poses all kinds of complications of dealing with judgments of irrelevance in trials in relation to the rules of evidence that guide a judge on how to determine relevance in court. These problems will be studied in chapter 8. Similar complications arise in connection with case 1.2. In this case, the legislator is arguing in the context of a political debate, presumably in some congressional or parliamentary meeting. Here too, there would be rules of relevance that are supposed to be interpreted and enforced by the Speaker. These problems are also studied in chapter 8. So both cases 1.2 and 1.3 are somewhat problematic to present to introductory logic students as instances of the fallacy of irrelevant conclusion. They are good cases to illustrate the importance of fallacies of relevance, but they throw open unanswered questions about how relevance should be determined in special contexts.

#### **4. PROBLEMS IN JUDGING AN ARGUMENT IRRELEVANT**

There are some other problems with evaluating case 1.3 as well. The premise ‘Murder is a horrible crime’ could be relevant if the prosecuting attorney was trying to prove that the defendant’s motive was consistent with the committing of an unusually horrible crime. Also, the premise of this inference is topically relevant to the conclusion because both propositions contain the term *murder*. There is a subject-matter overlap between the two propositions. The problem posed by these observations is that it cannot be entirely excluded that the premise could be relevant to the conclusion. Another problem with attempting to evaluate relevance in this case is that the prosecutor’s argument is being used in the context of a legal trial. In fact then, in such a case, the presiding judge

would have to determine whether the prosecutor's argument was relevant or not. Such a judgment would be based on how the argument was being used in a trial, in light of the charge against the defendant, and as determined by the rules of evidence applicable in that jurisdiction. However, in a logic textbook, we are presumably not dealing with legal relevance as a technical or legal judgment, but with logical relevance generally. This presumption poses a problem. Could the same argument be legally relevant but not logically relevant, or vice versa? Students in a logic class are in no position to pronounce on or judge whether an argument is legally relevant or not. But it hardly seems realistic or defensible to exclude legal factors determining relevance from the evaluation of the case altogether. For the case is a legal trial, where the prosecuting attorney is accused of using an irrelevant argument (committing *ignoratio elenchi*).

So this case has a number of subtle complications that make it difficult and problematic to use as a leading example of the fallacy of *ignoratio elenchi* in an introductory logic textbook. The problem is that the students do not appear to be given, or even to have access, to the resources or methods needed to evaluate whether the argument really is relevant in the given case. On the other hand, case 1.3 is an important kind of case in which judgments of relevance or irrelevance need to be made and which logic students, as citizens, should know about.

Relevance in political and legal argumentation was recognized as important in ancient manuals of rhetoric, designed to be used in cases of legal and political argumentation. Hermagoras of Temnos (fl. 150 B.C.) is widely credited with having developed the so-called *stasis* theory, which identified an argument as relevant if it addressed the issue of a controversy (Hohmann, 2001, p. 741). Hermagoras was on track (as shown in chapter 5) when he designed his concept of relevance in argumentation to center on the persuasiveness of arguments on "proposed political questions," meaning anything that involved a citizen, including deliberations, ethical discussions, and pleading in a court. But surely the standards for evaluating relevance in these different types of discourse will change significantly, depending on the purpose of the conversation, its institutional setting, and the particular rules and codes applicable to that setting. In a legal case, in particular, the setting being that of a trial, a conventional institution carefully defined and circumscribed by special legal rules as noted above, evaluating the relevance of an argument needs to take into account certain key factors of this setting. It might be better to start with everyday arguments that do not have these special complications.

Still, basic problems arise not just in legal cases, or in cases of political debate, but in examples of everyday argumentation. An excellent case illustrating some of the problems posed by textbook accounts of *ignoratio elenchi* can be found in an early logic textbook (Hibben, 1906). Hibben (p. 163) describes the fallacy of *ignoratio elenchi* as committed by "any argument which does not squarely meet the point at issue in a dispute," especially where the



argument is used as a “subterfuge which withdraws attention from the point at issue.” The following example is used to illustrate the fallacy:

*Case 1.4:* Suppose a student should be urged to spend more time upon his Latin or Greek, and he should excuse his negligence by insisting that in after life he would never find any practical use for his classics (p. 163).

One’s first reaction to this case is to reply that the student’s argument is relevant, precisely because it has a practical bearing on the professor’s argument. The student’s premise that he would not find a practical use for classics in “after life” (life after school) could be used to support a practical conclusion indicating some appropriate course of action. For example, it might be argued that the student could drop Greek and Latin and study subjects perceived to be more useful on the job instead. From this perspective, the student’s contention that he would not find any practical use for classics is a relevant argument, or part of a relevant argument, against the professor’s practical argument that he ought to spend more time studying Latin or Greek.

On the other hand, much appears to depend on the context of case 1.4. Suppose the situation is that it is too late for the student to drop his classics courses, and he is already committed to seeing these studies through to his examinations. In this version of the case, it could be argued that the student’s reply is relevant to the general issue of the practicality of taking classics courses, but it is not materially relevant to the specific issue at hand, namely, passing this particular Latin or Greek course or failing it. The student’s trying to rationalize his negligence by claiming that he will not find a practical use for classics after university is, in some sense, not a materially relevant argument. It may be based on a true, or arguably true, premise, but it is not materially relevant to the practical matter at hand, namely, the need to pass an exam or successfully complete a course of studies.

This case illustrates the ambivalent aspect of using this kind of example to illustrate the *ignoratio elenchi* fallacy. The student’s argument can be seen as relevant, according to one way of construing the context of the case. Certainly it is topically relevant to the issue of the case. However, when the case is construed another way, and this way also appears to be a permissible interpretation of it, the student’s argument is materially irrelevant. Once he has enrolled in the Latin or Greek course, and, presumably, when withdrawal is no longer an option, his argument, in Hibben’s words, “does not squarely meet the point at issue” (p. 163). So there seems to be a contradiction implicit in the case, depending on how you interpret the word *relevant* as applied to it.

## 5. MATERIAL RELEVANCE

A recurring problem posed by all the cases considered so far is the distinction between relevance generally and material relevance. To get a better practical grasp of this distinction, it is useful to examine a case in which there is a failure of material relevance, even though there is general or non-material relevance. Such a failure of material relevance is well illustrated in the following case:

*Case 1.5:* Mr. Smith, who is a patient in an intensive care unit and has an untreatable cancer of the pancreas, informs his physicians he wants to be taken off life-support systems. His wife disagrees and feels he should be kept in the intensive care unit. The physicians, staff, and family form a committee to discuss the problem, in order to try to arrive at a decision on how to proceed. Should Mr. Smith be taken off the life-support systems or not?

During the discussion, Dr. Jones, one of the attending physicians, starts to discourse on the general economic questions posed by this type of patient, saying, "It costs, on average, over thirty thousand dollars to maintain this kind of patient in intensive care. We have a growing national debt in this country. Can we, as a nation, really afford to maintain this expensive kind of treatment, when the money could be more usefully spent on things like preventative medicine? I think we need to reconsider our priorities in health care spending."

At this point in the meeting, another physician, Dr. Brown replies, "Financial questions of this sort are not really all that relevant to our present discussion of the specific problem we face here. Let's get back to the question of what we propose to do. Our problem is whether to keep Mr. Smith in the unit, or to release him to a medical ward, according to Mr. Smith's own request."

The economic argumentation advanced by Dr. Jones in this speech is relevant, in some sense, to the general issue being discussed in Mr. Smith's case. But would the other participants in the discussion be inclined to think that it was really relevant to confronting the specific problem of deciding whether to take this patient off the life-support systems or not? The participants in the committee meeting might well feel that this argument is not relevant because no matter which side you take on that issue, it is not going to decide what should be done in the case of Mr. Smith.

It could be quite reasonable to rule that Dr. Jones's argument is not materially relevant, from the point of view of the particular committee that has to decide what to do in Mr. Smith's case; such general financial considerations do not decide this issue. This is a bedside decision, which needs to be made in

the context of limited time if it is to be meaningful. Going into the larger question of how the different sectors of medicine are granted financial allocations in the country will not, in any way, materially affect the outcome of the particular case of Mr. Smith. In this case, there appears to be a contradiction, because Dr. Jones's argument is relevant, but it is not relevant (in another sense). To resolve the contradiction, we need to clarify the distinction between something that is generally relevant in a discussion and something that is materially relevant.

Here Dr. Brown might not be denying that financial considerations are relevant to the general issue under discussion. But he might be right that they are not materially relevant because the committee is not dealing with this larger economic problem within the framework of their present discussion. These larger economic issues, although generally relevant, are still not going to affect the outcome of this decision, one way or the other, in any practical way.

In this case, the type of conversation the participants are involved in is that of a committee meeting, formed for the express purpose of arriving at a decision on what to do in Mr. Smith's case. This type of conversation could be described as deliberation. The purpose is to decide on a course of action by letting all the involved parties say what they think about the issue and then trying to formulate the most important arguments for and against the various possible options. The goal would be to arrive at some sort of rationally based consensus—a reasonable course of action that all can agree to as the best way to proceed. Thus, the discussion in this case is a practical one and is a matter of some urgency. Delay and protracted argumentation will mean that, in effect, Mr. Smith will be kept in the intensive care unit against his expressed wishes. So even a failure to do or to decide anything results in a definite line of action—more accurately, an omission or failure to act—that has definite consequences.

Material relevance depends on the specific facts of a case. How can these be judged? Surely the facts of case can vary, as new evidence comes in. In some cases, like those above, all the facts of the case may not be known. How much factual knowledge of a case should a judgment of material relevance rest on? These questions suggest even deeper ones. What does it mean to say that an argument, as used in a case, according to a particular interpretation of the facts in that case, is not materially relevant, or, to put it another way, “does not squarely meet the point at issue”? In this context, an argument (or other speech act) is *materially relevant* in a conversation if it bears directly or strongly on the issue so that it is worth prolonged or detailed consideration in relation to the specific problem or issue that the conversation is supposed to resolve. As case 1.5 illustrates, an argument can be generally relevant, or relevant in some other sense in a conversation on an issue, but not materially relevant. For example, Dr. Jones's argument on the costs of intensive care in the national health care budget is topically relevant to the issue of whether Mr. Smith should be removed from the intensive care unit or not. But it is not materially relevant, in

the sense that it does not bear directly on the decision of what to do in the case of Mr. Smith.

Whether an argument is materially relevant in a given case depends on the context of conversation in which the argument is located. It depends on the purpose of the discussion. There is another factor to be taken into account. Dr. Jones's argument may be worth mentioning, as one generally relevant factor that applies to this kind of case. But the time allotted for the committee meeting would clearly have to be limited by practical factors. Too much time spent on discussing the general issue of health care economic policies would have a bad effect on the quality and success of the deliberations in the committee meeting on the case of Mr. Smith. Thus the exclusionary function comes into play, just as shown in cases 1.1 and 1.2. In this new kind of case, however, there would be no rules of relevance and other highly codified legal rules of procedure, as there are in a legal trial or other legal proceedings. The committee would feel a practical need to limit digressions because of the limited time available to the participants and because of the urgency of the decision. However, these same practical factors of time and expense would bear on a legal trial. The judge would interpret rules of relevance more strictly where costs and other practical matters would limit the time allotted for a trial.

So far, our best bet in trying to work toward an answer to these questions is to look at examples of perceived irrelevance and try to diagnose the problem. To proceed further in this direction, the best thing is to examine some other cases where irrelevant arguments have been perceived to be problematic.

## 6. OTHER FALLACIES OF IRRELEVANCE

Logic textbooks generally treat relevance within the part of the logic course devoted to informal fallacies. Many treat a certain specific subset of the fallacies as being fallacies of relevance. Four particular fallacies are most typically classified as belonging to this subset. *Argumentum ad hominem* is the use of personal attack by one party in a dispute to attack the other party's argument by alleging that this other party has a bad character, for example, a bad character for veracity, so that he lacks credibility as a spokesman for his argument. *Argumentum ad misericordiam* is the use of appeal to pity by one party to try to get another to accept a conclusion or policy, or to make a concession. *Argumentum ad baculum* is the use of appeal to force, or the threat of force, or to fear generally, to try to get a respondent to accept a conclusion or go along with a recommended course of action. *Argumentum ad populum* is the use of appeal to popular opinions or feelings to accept a conclusion or course of action. In some textbooks, all four types of appeals are treated as inherently fallacious, primarily on the grounds that they are irrelevant in a serious argument where objective evidence is supposed to be given to prove a point. Other textbooks

leave room for the possibility that such arguments may not be fallacious in some cases. They then inform their readers that these four types of argument are fallacious whenever they are used in an irrelevant way.

However they treat this group of fallacies, the textbooks most often explain their fallaciousness as a failure of relevance. For example, in the widely used textbook *Introduction to Logic*, Irving Copi and Carl Cohen (here the eighth edition is cited, 1990, p. 103) classify the *ad populum*, *ad misericordiam*, and *ad baculum* together under the heading of appeals to emotion. They diagnose the common fault as failure of relevance.

These three fallacies, although common enough, are also so evidently fallacious as to require little explanation here. In each case the premises are plainly not relevant to the conclusion, but are deliberately chosen as instruments with which to manipulate the beliefs of the listener or reader.

Clearly, for Copi and Chohen, the presumption is on the side of these arguments being fallacious.

Although the *ad hominem* has distinctive features in its own right as a separate type of fallacy, it is also strongly associated with appeal to emotion and with failure of relevance, by many textbook accounts. Hence, the four fallacies—*ad hominem*, *ad misericordiam*, *ad baculum*, and *ad populum*—are often treated as the four main fallacies of relevance. Yet, there is also a longstanding tradition to cover a broader range of the fallacies under the general heading of fallacies of relevance. Copi and Cohen (1990, p. 93) cover twelve fallacies under this heading. Hurley (5th ed., 1994), another widely used logic textbook, treats eight fallacies under it (p. 116).

Each of the various fallacies treated under the heading ‘fallacies of relevance’ is, to a greater or lesser degree, explained as a fallacy because it involves a failure of relevance. Yet each of the individual fallacies treated has its own special features that make it a fallacy distinct from the others. One fallacy that is frequently singled out as being a pure failure of relevance, without any of the distinctive or special features of one or more of the other fallacies being involved is the so-called *ignoratio elenchi* (misconception of refutation) or “irrelevant conclusion” fallacy. Copi and Cohen (1990, p. 105) write that this fallacy is committed when an argument “misses the point” or is used to prove some conclusion other than the one it was supposed to prove. The idea is that this fallacy is the use of the tactic of digression or distraction to throw an opponent off the subject or off the line of argument supposedly being discussed. Many textbooks use the expression *red herring* to convey the idea of this familiar tactic of argumentation. According to Engel (1976, p. 97), for example, “To sway a red herring in an argument is to try to throw the audience off the right track onto something not relevant to the issue at hand.” Engel explains (p. 97) that the name *red herring* derives “from the fact that escapees sometimes

smear themselves with a herring (which turns red or brown when it spoils) in order to throw dogs off their track.” According to Hurley, (2000, p. 131), the name comes from practices used in training hunting dogs.

The fallacy gets its name from a procedure used to train hunting dogs to follow a scent. A red herring (or bag of them) is dragged across the trail with the aim of leading the animals astray. Since red herrings have an especially potent scent (caused in part by the smoking process used to preserve them), only the best dogs will follow the original scent.

Whichever explanation is historically correct, the reader gets the idea, as we are all familiar enough with the use of digressions and distractions as tactics used in everyday argumentation.

The other common phenomenon in textbook treatments of the fallacies is that the idea of relevance is stretched so thin that virtually all of the informal fallacies are explained in sweeping terms as failures of relevance. Here, relevance, as Hamblin (1970, p. 31) noted, has become a wastebasket or “rag bag” category. If you’re not sure or can’t explain why an argument is fallacious, then just toss it into the wastebasket category of “failure of relevance.” One special problem is the straw man fallacy, the tactic of distorting or exaggerating an opponent’s position, in order to make it look implausible, and then attacking this implausible position. To cite the example presented in section 8 below, an environmentalist position may be attacked by saying that it advocates the elimination of all private property. The problem with such a case is that it seems that the fault is a failure of relevance. In fact, it turns out to be quite difficult to solve the problem of distinguishing between the straw man fallacy and the fallacy of irrelevant argument.

## 7. IRRELEVANCE IN LEGAL ARGUMENTATION

Another problem with the traditional account of fallacies in logic textbooks is that many of the arguments said to be fallacious in textbooks can, in fact, be non-fallacious in legal argumentation. Does this indicate that law is based on fallacious arguments? Quite to the contrary, it indicates that these allegedly fallacious arguments can quite often be reasonable, that is, non-fallacious, under the right conditions. For example, an appeal to pity could be irrelevant in a trial if used to try to prejudice a jury by gaining their sympathy, leading them to overlook strong evidence of the defendant’s guilt. But once guilt has been proven in a trial, an appeal to pity could be relevant at the sentencing stage. Or, to consider the case of *argumentum ad populum*, community values can sometimes be a relevant consideration in law. Or, to consider *argumentum ad baculum*, it might be noted that judges often make threats in trials. Does that

mean they are committing fallacies? It does not, because the threat of a fine, or other penalty, can be a useful and relevant way for a judge to see that a trial is fair. Of all four fallacies of relevance, the *argumentum ad hominem* is the most interesting and controversial with respect to relevance in law. Such arguments are, by no means, always fallacious in law.

Arguments attacking the character of the defendant or a witness are sometimes allowed as relevant in legal argumentation. In some cases, it is easy to see that this kind of argumentation is vital evidence in a trial. For example, if the testimony of a witness is important evidence in a trial, but there are doubts about the credibility of the witness, it should be proper for a cross-examiner to raise questions about the honesty of the witness. Attacking the character of the witness by showing that he has lied, or that his story is not consistent, should be allowed as relevant in a trial. Matters of the character of the witness are rightly seen as relevant because the guilt of the defendant may rest heavily on the testimony of one witness. If that witness is lying or mistaken, the defendant may be unjustly convicted. The only defense may be to probe deeply into the testimony of the witness and test it for consistency and plausibility. If there is evidence that the witness is lying, or is dishonest, the jury needs to know about it to fairly balance the weight of evidence on both sides. In our system of law, therefore, the *argumentum ad hominem* should sometimes be relevant, provided it is used at the right time in a trial.

In both early English law and Roman law, much of the argumentation in a criminal trial tended to be centered on the moral character of the defendant. There were no limitations on character evidence in early English law. Gradually, arguments based on character began to be more and more prohibited. According to Leonard (1998, p. 1170), rules excluding character evidence to prove or disprove a person's conduct were settled firmly by the early nineteenth century.

At the present time in Anglo-American law, character evidence is still seen as relevant, but there are many restrictions on how and when it can be used in a trial. The most notable rule making character evidence irrelevant is Rule 404 of the now widely accepted Federal Rules of Evidence. Rule 404 states that character evidence is not admissible to prove conduct. Essentially what this rule amounts to is an exclusion of the argument, 'He is a bad person; therefore, he committed the crime.' The rule essentially bans the use of the *argumentum ad hominem* as irrelevant. Numerous exceptions are stated right in this rule, however. Character can be used to prove motive, opportunity, intent, preparation, or other factors that are relevant as evidence in a criminal trial. There are also other exceptions. Rule 608 allows that the credibility of a witness may be attacked or supported by evidence in the form of opinion or reputation, but only evidence for his truthful character. Another exception is a case in which character is the main issue. For example, in a civil case, the main issue might be negligent hiring or negligent entrustment. In this kind of case, the character of the person would be ruled as relevant to the main issue of whether

the defendant was negligent in hiring or entrusting property to an unfit person (Landon, 1997, p. 584). Another exception to Rule 404 is that a defendant in a criminal case can argue for his own good character. But once he does so, the floodgates are opened. It is then held to be relevant for the prosecution to question that claim by bringing forward evidence of the defendant's bad character.

An example of a famous case in which relevance of character evidence was an issue is the televised criminal trial of O. J. Simpson. Even before the opening statements of the trial, lawyers for both sides were arguing with the judge about whether evidence that Simpson had stalked and beaten Nicole Brown Simpson should be admitted (Park, 1996, p. 748). The defense argued that this was character evidence, and was therefore not relevant. The prosecution argued that it showed a plan in which murder was the final outcome. They argued, therefore, that this evidence was relevant. In the end, Judge Ito admitted most of this evidence as relevant even though he excluded some of it. His rationale was a previous California ruling in favor of admitting evidence of prior assaults on the same victim in homicide cases (Park, 1996, p. 752). Character evidence of this kind, like evidence of previous convictions, is known to exert such influence on a jury that the lawyers for both sides will argue strenuously about whether it should be judged relevant even in the pretrial stages.

These observations offer a clue as to why there are so many restrictions on the use of character evidence in law. History of law offers other clues. The historical reason for excluding *argumentum ad hominem* as irrelevant is that it tended to be such a powerful argument in criminal trials that it could easily overshadow all other evidence. It could be so strong that it could even prejudice a jury to disregard other evidence. Thus, as Landon (1997, p. 584) described the history of the subject, "Rule 404 is the sum of hundreds of years of court wrestling with the question of what is the appropriate place of evidence as to the defendant's character in a criminal or civil trial." One can easily see why the *ad hominem* argument is so powerful in a criminal trial. If the defendant looks like a criminal, because he has previous convictions or because he can be shown to have a bad moral character, a jury is quite naturally inclined toward the view that he is guilty. Another reason is that, especially when used as a surprise tactic, it can be quite hard to defend against. Trying to deny such an argument too strenuously can make you look even more guilty. Yet another reason is that people tend to be suspicious even in the absence of evidence for or against such an attack. Even unfounded rumors or gossip about a person's bad character can easily prejudice them against him. It may take many years for a person to build a good reputation, but one personal attack can destroy it even if the attack is based on very little hard evidence.

The problem with legal argumentation is comparable to that noted earlier about judging relevance in a political debate. The problem is posed by the existence of institutionalized procedural rules of relevance that are applied by an



overseer of the dispute, in order to determine whether specific arguments are relevant or not. To grasp legal relevance, you have to understand how it is codified in rules of evidence and how the rules relate to some underlying concept of relevance they are supposedly based on. The decision of whether or not something is relevant in a trial is made by a judge. The judge will use the rules of evidence to make the determination. The Federal Rules of Evidence (FRE) are generally used in the U.S. legal system to determine relevance in a trial, even though these are federal rules, and not every court follows them exactly. Most states either use the FRE or rules that are very close to the FRE. The FRE begins by defining relevant evidence as follows:

**Rule 401:** “Relevant evidence” means evidence having any tendency to make the existence of any fact that is of consequence to the determination of the action more probable or less probable than it would be without the evidence (Article IV).

One question here is what is meant by “more probable” and “less probable.” The FRE does not define these terms, but it is fair to assume that they can be taken to refer to what Wigmore’s theory calls “probative weight” (Wigmore, 1983).<sup>1</sup> Another question is what is meant by the expression “of consequence to the determination of the action.” The “action” is the ultimate proposition to be proved or put in question in a given case. It refers to the ultimate issue in the case. Thus, to be “of consequence to the determination of the action” is to be part of some chain of argumentation that has the “action” as its ultimate conclusion. So conceived, Rule 401 can be taken as a kind of definition of legal relevance, as applied to the determination of an action in a trial.

Rule 402 goes on to state that relevant evidence is generally admissible in a trial and that irrelevant evidence is not admissible. But some divergencies between legal and logical relevance start to come in, as exclusions of relevant evidence are introduced into the rules. Rule 403 excludes relevant evidence on grounds of prejudice, confusion, waste of time, or duplication of previous evidence.

**Rule 403:** Although relevant, evidence may be excluded if its probative value is substantially outweighed by the danger of unfair prejudice, confusion of the issues, or misleading the jury, or by considerations of undue delay, waste of time, or needless presentation of cumulative evidence (Article IV).

---

<sup>1</sup> The full title of the work referred to as Wigmore’s *Treatise* is *A Treatise on the System of Evidence in Trials at Common Law*, first edition published in Boston in 1904–1905. The later edition, edited by Peter Tillers, cited in chapter 8 as ‘Wigmore (1983),’ contains important commentary on relevance issues.

Rule 403 shows most dramatically the distinction between logical relevance and legal relevance, as defined by the FRE. Even though a piece of evidence is logically relevant in a case, it could still be excluded by Rule 403 on the grounds that its probative value is outweighed by other factors. For example, if the evidence might tend to prejudice the jury, it could be excluded even though it is relevant in the logical sense. The exclusion of certain kinds of arguments that are logically relevant, but are ruled legally irrelevant, will be considered in chapter 8. *Ad hominem* attacks on a person's character, for example, could be logically relevant, but could be excluded under Rule 403.

Federal Rule 404 specifically takes up character evidence. According to Rule 404, character evidence is not generally admissible, meaning that the prosecution cannot use the argument, 'The defendant is a bad person (has ethically bad character), therefore he is guilty of committing the crime he was alleged to have committed in this case.' This form of argument does carry some probative weight as a persuasive argument, as indicated above. It is not always a fallacious argument. But it is not generally allowed by the FRE. However, as noted above, several exclusions are made. For example, evidence of the character of a witness who is offering testimony can be relevant in cross-examination to show that the witness is dishonest. These rules on character evidence define how the FRE deals with *ad hominem* argumentation. In many cases where *ad hominem* arguments are logically relevant, from a point of view of everyday reasoning, they would be excluded from a trial by the FRE.

How could the legal notion of relevance used in the FRE be based on some underlying kind of logical relevance, given these divergencies between the two notions? The best we can provisionally conclude here is that it appears that the legal notion of relevance in Anglo-American law should be based on some underlying notion of logical relevance. If so, it would appear that despite the special legal factors introduced by law as an institution with its own rules of relevance, and the difficulties and complications introduced by such rules, logic should have something to say about cases like 1.3. Needless to say, considerations of such institutionalized contexts of argument use, like law and political debate, pose special problems. These substantive problems are taken up in chapter 8.

## 8. THE STRAW MAN FALLACY

The logic textbooks have a tendency to confuse the fallacy of *ignoratio elenchi* and the straw man fallacy. To try to sort out what the difference is between irrelevance and the kind of failure associated with the straw man fallacy, it is best to begin by considering a typical case of the straw man fallacy. The following case, which could be called the "green position case," is quoted

directly from Walton (1996). In this case, one participant in a discussion of environmental issues attributes a so-called “preservationist” position to the other participant. The preservationist position is generally taken to be extreme, meaning that it is a view that many environmentalists see as being too restrictive in regulating what can be done on protected lands.

*Case 1.6:* Bob and Arlene are arguing about environmental laws that regulate industrial pollution, and Bob has taken a moderate “green” position. Arlene argues, “People like you want to make the planet into the pristine place it was hundreds of years ago. You preservationists don’t want to let anybody do anything to the land that could possibly have ecological consequences. Therefore, what you are committed to is the elimination of all private property and all industrial manufacturing. Imagine the unemployment and social destruction of private homes implied by this” (Walton, “Straw Man Fallacy,” 1996, p. 120).

In this case, there is no evidence (let’s say) to justify Arlene’s accusation that Bob’s position is as extreme as she portrayed it in her rebuttal. Judging by the accounts indicated in chapter 5 (section 8), it could be said that Arlene has committed the straw man fallacy in the green position case.

The straw man and *ignoratio elenchi* are closely related dialectical fallacies. It will be shown in chapter 5 how they can easily, and quite understandably, be confused in the logic textbooks. When an opponent’s position is distorted or exaggerated in a straw man argument, the effect is often to divert the line of argument to irrelevant issues. So the straw man argument, as typically used, involves an aspect of irrelevance. In the green position case, a critic might naturally enough diagnose the fault of Arlene’s argument as a failure of relevance, by saying, “Her argument that Bob’s position has the consequences of unemployment and destruction of homes is irrelevant. It is beside the point and doesn’t prove anything because Bob’s real position does not have these consequences at all. Her argument is a red herring, which takes us away from the real issue.” It is easy to see how, in a case where the straw man fallacy has been committed, the failure may be naturally perceived as one of irrelevance (*ignoratio elenchi*). In many cases, textbook accounts of the two fallacies appear to allow them to overlap considerably, and it is not surprising to find examples in the textbooks, like case 1.6, where the two appear to be mixed up. Case 1.6 is more naturally classified as a case of missing the point (*ignoratio elenchi*) even though Bonevac (1990) classified it as a case of the straw man fallacy. The basis of this classification is the conclusion that the trade bill argued for by the senator will solve all the problems cited and that it is the best plan. Bonevac’s evaluation, in terms of the new theory, can be analyzed as showing

the difficulty of making an argument extrapolation to the conclusion to be proved.

Other textbooks have gone in the reverse direction and given examples classified as cases of the fallacy of *ignoratio elenchi* that seem as though they might more naturally, or more specifically, be classified as instances of the straw man fallacy. For example, Castell (1935, p. 21) classified the following inference in case 3.6 as an instance of the fallacy of irrelevant thesis.

(I 4.6)      Need anyone be reminded that we are sadly mistaken if we think we shall, by letting things look after themselves, attain to any social utopia.

---

Laissez faire is an unsound principle of social philosophy.

The inference (I 4.6) would more naturally be classified as an instance of the straw man fallacy, according to the definition of the fallacy given by Johnson and Blair (1983, p. 74), and the new pragmatic theory of relevance. For the problem with this case that stands out is the exaggeration of the position of the *laissez faire* exponent by describing it as having the goal of trying to attain a “social utopia.” This exaggeration of the arguer’s position, to make it seem to be a kind of desire to attain perfection, is presumably a tactic of argumentation to make the position easier to refute. Hence, the argument represented by (I 4.6) is more naturally and more specifically categorized as an instance of the straw man fallacy than as an instance of the *ignoratio elenchi* (irrelevant conclusion) fallacy. Straw man is getting your opponent’s position wrong and then refuting that wrongly attributed position. Irrelevant conclusion is getting your opponent’s conclusion wrong, that is, the thesis your opponent is supposed to be proving, and then refuting that wrongly attributed conclusion. These are similar tactics, however, for both involve the refutation of something wrongly attributed to the other party in a dispute.

Little, Groarke and Tindale (1989) define straw man and red herring as fallacies in a way that brings out the essential difference between the two. They define straw man (p. 195) as follows.

We often find ourselves summarizing an opponent’s position for purposes of clarifying it or attributing certain consequences to it, and then arguing against it. When we do this, we must be sure that the opposing position has been fairly and accurately represented. If our version is wrong, whether it is deliberate or through an oversight—if we take our opponent’s position to be A when she intended B, and then proceed to attack A—we are guilty of the type of contextual irrelevance known as a “Straw Man” argument. A straw man is always a misrepresentation of a

position, usually weakening it to make the response easier and apparently more effective.

Straw man, as a fallacy, is defined as misrepresentation of an arguer's position. Of course, the arguer's thesis, the conclusion she is supposed to be arguing for as her main goal in the critical discussion, is a central part of her position. But that proposition, by itself, is not identical with her position. Her position is also defined by how she has defended that thesis during the course of the dialogue so far, as indicated by the given text of discourse. Her position is defined as the whole set of her commitments, as determined by all the assertions, arguments, and all the other moves she has made so far in her discussion of the issue. This account brings out the importance of the distinction between an arguer's conclusion, or thesis to be proved in the dialogue, and her position, or known set of commitments in the dialogue. These commitments are presumably indicated by the text of discourse in the case.

Little, Groarke, and Tindale classify both straw man and what they call red herring as fallacies of contextual relevance, but they make the distinction between them clear (p. 198).

The second type of contextual irrelevance is what has been traditionally termed "Red Herring." What distinguishes this from straw man reasoning is that there is no misrepresentation of a prior position or context. Rather, the shift takes place within the argument as the boundaries of the issue are altered through the introduction of a quite irrelevant consideration.

What defines red herring is the original conflict of opinions, the pair of propositions that are opposed to each other, and which determines the global burden of proof for each participant in a critical discussion. This conflict defines "the boundaries of the issue" and the red herring fallacy is the attempt by one party or the other to stray outside these boundaries or to start discussing a different issue. The straw man is quite different as a failure of argumentation or a sophistical tactic. It is directed by one party toward refuting the other by distorting or misrepresenting the position of the other in the premise used in the refutation. The failure here is a failure to engage with the real position of the other.

Here, then, is the basis of the difference between the *ignoratio elenchi* fallacy and the straw man fallacy, in the context of a critical discussion. The *ignoratio elenchi* fallacy is committed when the proponent's argument cannot be extrapolated forward by any plausible or convincing sequence of reasoning, so that it winds up at the conclusion to be proved by him in the discussion. The straw man fallacy is committed when the proponent's argument is based on premises that do not represent the commitments of the other party in the dispute, and where his argument used a distorted version of these commitments to try to

refute the other party. What needs to be sharply distinguished are (1) the arguer's commitments in a given case, as represented by the evidence in the case, and (2) the right conclusion to be proved by an arguer in a given case. The problem with the logical theory currently used by the logic textbooks is that it does not have the sort of structure of argumentation necessary to make this distinction.

## 9. RELEVANCE AS RELATIVE TO A DISCUSSION

In negotiation, much of the work at the stage prior to the substantive negotiations involves argumentation on what items will be on the agenda of a meeting and in what order they will be discussed. For once an issue has been excluded from the agenda, even though it may turn out to be relevant as the argumentation proceeds, it can be objected to as "irrelevant" if it was not on the initial agenda. Thus, the whole notion of relevance can be worrisome to participants in a negotiation, even before bargaining over the main issues begins. They see it as a tool not only of exclusion of issues they want to bring up, but even of suppression of their right to bring up important matters for discussion.

The worry that something could be excluded arbitrarily as irrelevant at the agenda-setting stage is not restricted to negotiation discussions. Another possibility concerns a kind of case that should be given careful thought. Suppose a meeting is set, and the issue on the agenda is whether one course of action, or another incompatible one, is to be taken. For example, the discussion could be a parliamentary debate on whether to vote for one policy, or another, each of which represents an alternative course of action.

*Case 1.7:* Someone speaks up from the audience during the course of the meeting, and argues: "I think we should reconsider the question of whether any course of action at all should be taken. We need to rethink the problem, and consider other alternatives, including the option of taking no action at this time."

In a case like this, which represents a kind of situation that could be fairly common, it could be that the speaker from the audience has proposed a policy that is, in fact, the most prudent solution to the problem confronting the participants in the meeting.

For example, suppose the problem is a diplomatic impasse in negotiations on a conflict over disputed territory, and the meeting is part of the attempt by a peacekeeping group to deal with the problem. Two courses of action have been proposed, one recommending that the territory be shared one way, and another recommending a different division. The meeting is then called to decide

between these two plans. Suppose the chairperson of the meeting addresses the speaker from the audience as follows: "Your proposal is not relevant to the item on the agenda, namely, the question of which plan we should vote for." By invoking relevance, the chairperson rules the speaker's proposal out of the boundaries of the discussion and thereby makes it ineligible for consideration.

This kind of case poses a general problem for the evaluation of arguments based on the concept of relevance. Suppose the speaker in the audience is right, and doing nothing for the moment, while reconsidering the problem, is really the most prudent thing to do. Suppose that it will have the best results in preventing the conflict from escalating. From this point of view, the speaker's argument is relevant and is a good argument. But from the point of view of the agenda of the meeting, that argument is not relevant. From this point of view, it is not an admissible argument and may be evaluated as irrelevant, with reference to the agenda previously set. Hence, from this point of view, it may properly be excluded from consideration.

This kind of case seems to challenge the whole idea of relevance as a way of evaluating arguments. In this kind of case, an argument can rightly be criticized or ruled out of place as irrelevant while, at the same time, being practically reasonable as a means of solving the problem that is being addressed. In other words, relevance in relation to the goals of a set discussion may not represent the only standard of adequacy used to judge an argument in a given case. There may, it appears, be another standard of what a good argument should be, which could override the relative evaluation of an argument in relation to the goals of a framework of dialogue. This kind of case raises a general issue for relevance as a way of evaluating arguments. For when one judges a particular argument as relevant or not, as used in a particular type of dialogue framework, there can always be a prior question of whether this framework is the right one to solve the problem that the meeting or discussion was set up to solve.

This kind of case also raises a practical problem of when to use the device of forcing the participants to stick to the agenda of a meeting. In some broader perspective, there may be good reasons for reconsidering or changing the agenda. If so, the objection of irrelevance could be used as an aggressive or unfair tactic to suppress arguments that really should get a hearing. Here, the danger is that the charge of irrelevance, or the allegation that someone has committed a fallacy of relevance, will itself be used as a fallacious tactic to try to prevent someone from expressing a point of view. It could be, in case 1.7, that from a point of view of deliberation on the problem, the argument of the person who spoke up from the audience was dialectically relevant. Even so, within the format and agenda of the parliamentary debate in which the person spoke, the chairman of the meeting was right to rule the argument as irrelevant. So here we have a difficult problem. Who was right? Surely the argument was either relevant or not. So if what really matters is intelligent deliberation on the

issue, then the whole idea of relevance defined by the rules of a parliamentary debate is just an illogical trick to suppress good arguments. It is a kind of artificial regimentation of speech used to forcibly repress the real, free kind of thinking that should naturally take place. This very same problem was made clearly evident in connection with the legal rules of exclusion of logically relevant arguments, like character attack arguments. Couldn't these rules be a way of preventing arguments from being used in a trial even if they really are logically relevant to the issue in the case being tried?

What these considerations suggest is that relevance can be judged in two ways. It can be judged as internal to a discussion once the agenda for the discussion has been set or it can be judged as external to a discussion. For example, prior to the beginning of the discussion, the participants can argue about the agenda. Even during it, a participant may contend that an important argument should now be considered even if it is not on the agenda set previously. Surely an important factor in such cases is the prior agreement of all participants to an agenda before any actual discussion or negotiation begins. Setting an agenda can be useful, or even necessary in some cases, to give the discussion a realistic chance of success.

The general lesson that emerges from such considerations is that relevance and irrelevance should be judged as relative to a given discussion. If the conversation changes to a different one, what is relevant in the first discussion might be irrelevant in the second one. Wigmore (1935) showed a clear recognition that relevance depends on the type of conversation that two parties are supposed to be engaged in. Wigmore (1935, p. 8) gave the following example to explicitly illustrate how a switch from one type of discussion to another can be a source of irrelevance:

*Case 1.8:* When you and your friend have met to dine at the restaurant, and the attentive waiter lays before each of you a copy of the menu, and the guest is concentrating upon the question "What to choose?" suppose that you, in your zeal for the horticultural topic just discussed with him, continue thus: "What proves that the Corona rose can be grown from cuttings in this climate is the testimony of four of my neighbours who did that very thing last winter!" Then might not your friend mildly protest, "I cannot listen to that testimony now, because the only issue before us is whether we are to consume a lamb chop or a porterhouse steak" (*Student's Textbook*, 8).

Wigmore commented (p. 8) that the argument about rose transplantation is irrelevant or "immaterial at the present moment" because the "immediate issue" is the menu. This particular example is highly significant because it shows very clearly how irrelevance is a pragmatic and contextual matter of the context of



conversation. In particular, it is the shift from one type of discussion to a different type that accounts for the irrelevance of the argument.

Wigmore's analysis of legal relevance proved to be practically useful and insightful because the problem he continually addressed is how scientific and forensic evidence can be used, and can constitute relevant evidence, in a court of law. Clearly, the trial is one type of argumentative type of discussion, whereas scientific argumentation comes from quite a different framework of evidence. How can scientific evidence be relevant in a trial? To answer this question, some account needs to be given of how an argument can shift from one pragmatic framework of use to another.

## 10. THE DIALECTICAL NATURE OF RELEVANCE

The cases analyzed in this chapter show that examples where failure of relevance is cited as a problem or fallacy are based on a concept of relevance we have called material relevance. Material relevance is a matter of how an argument is used to prove a point or discuss an issue in a line of argumentation in a given case. Material relevance is a dynamic concept that relates to how a connected sequence of argumentation is used in a case to relate the presumed facts of the case to the conclusion to be proved in that case. One implication to be drawn from these findings is that material relevance is a dynamic concept that cannot be structured only by the model of an argument as a localized inference from a set of premises to a single conclusion. Material relevance is a matter of how a potentially long series of connected inferences is used to come to grips squarely with an issue in a given case. Relevance is therefore a dialectical concept in that it relates to how a chain of argumentation is being directed toward some ultimate end point that is an issue of a discussion. Relevance, defined dialectically, also has rhetorical aspects.

Such matters of how a chain of arguments can be relevant to the issue of a discourse have been largely ignored in the history of logic. They have, however, been studied closely in rhetoric, as far back as Greek rhetorical manuals. This historical background of the concept of relevance as it developed in both rhetoric and logic will be outlined in chapter 4. Drawing on the ancient framework of Hermagoras, it will be shown that the relevance of an argument in a case is principally determined by what the issue in the case is supposed to be. As the ancients knew well, and as Quintilian ably explained, abstraction is also important in determining, in light of a given issue, what is relevant at the particular stage of a discourse, once the issue has been stated at a prior stage. What is judged to be materially relevant or not, at any given stage of a sequence of argumentation, depends on how the sequence has evolved at that stage. Such matters need to be judged by examining the text of discourse in the given case. One needs to ask what the purpose of the discourse is supposed to be. If it is

supposed to be to prove something, one needs to ask what that something is or should be taken to be. It depends on the issue that is to be decided or the problem that is to be solved. Something should only be excluded as irrelevant if it is not useful for proving what should be proved or for solving the problem that should be solved.

Case 1.5 shows why determining relevance, in the sense needed to properly evaluate arguments in particular cases, is not going to be as easy as it may have seemed to the textbook writers on fallacies of relevance. Dr. Jones' arguments on economic questions about the allocation of medical resources is, in a way, relevant to the issue, in case 1.5, of whether Mr. Smith should be kept in intensive care. It certainly is a related issue. On the other hand, it is a digression from the urgent deliberations on the immediate decision that needs to be made and is not really going to affect that decision one way or the other.

Similarly, in case 1.1, Harry's argument is, in a sense, relevant. But Pam's objection, questioning its material relevance for the purposes of the committee meeting—which after all, has an agenda set, and a limited amount of time to discuss the items on that agenda—is surely reasonable and appropriate. So to arrive at an appropriate definition of relevance that can be shaped into a theory that would be useful in evaluating criticisms of irrelevance in realistic, particular cases, one needs to grasp the target concept of material relevance. The key aspect of material relevance is that it is more than topical relevance and more than just relevance in the broad sense of having something to do with a proposition or issue being discussed or being some aspect of a case. It is a kind of relevance that is embedded in a framework of how an argument is supposedly being used to prove something in a practical way. What was found to be important to evaluating relevance in the cases analyzed in this chapter was that each argument was used in a dialectical framework that determined what was or was not relevant in a dialogue.

Some of the cases considered in this chapter involve special institutional contexts of argument use that cannot really be evaluated apart from procedural rules that govern a debate or that constitute due process in a court, for example. Some of the cases were legal arguments, and the legal framework of the trial, the type of case (criminal or civil), and the rules of evidence and other procedural rules all determined what was considered relevant or not. Other cases were committee meetings, one of which had a chairman who was supposed to make rulings on what is relevant in the meeting. Another case was a political meeting where a senator spoke with reference to a bill being debated. In all these cases, a particular type of discussion, proceeding, or meeting was the venue of the case, establishing a framework that defined what was considered relevant. Of course, formal dialectic, as a branch of logic, is not in a position to establish what should be considered legally relevant or irrelevant in a parliamentary or Senate debate where the participants are bound by particular parliamentary or senate rules of procedure. The special rules of procedure

governing meetings of this sort need to be taken into account. Some of these special rules are taken up in chapter 8 to indicate how they affect judgments of relevance.

Even before this point, however, a dialectical approach has something to say. Each meeting of a particular sort represents a type of discussion that does have a general purpose. The language used in putting forward an argument or asking a question can be viewed as an action done for a purpose in the conversation it was part of, a so-called speech act (Kearns, 1984, p. 1). Hence, dialectical methods of informal (applied) logic and the critical evaluation of argumentation are potentially useful here. In a political debate, for example, the debate has an issue. Hence, as in case 1.2, some conditional evaluation of the case may be useful from a dialectical point of view. A conditional evaluation is one that is made with appropriate qualifications about the special situation. For example, it could be made relative to the agreement of the participants to adhere to Senate rules of procedure as applicable to the discussion. Similarly, with respect to a legal example like case 1.3, any evaluation of the relevance of the argument used in the case would not be expected to be so specific that it would replace the function of the judge. The judge is expected to rule on relevance and irrelevance in a given case in a specific jurisdiction, according to the rules of evidence for that jurisdiction. Even so, it can be extremely useful for dialectical argumentation theory to study problems and fallacies of irrelevance in legal and political cases, taking these specific conventions into account. Suppose an attorney exploits tactics of digression in a sophistically deceptive argument that should be criticized as irrelevant or even fallacious. Dialectical argumentation theory should have something useful to say about such a case, even though care needs to be taken to realize the limits of what can be said.

## Historical Background

There are two pretty much independent streams of thought in the history of the concept of relevance. As indicated in chapter 1, relevance was a powerful and clearly defined rhetorical idea in the ancient world. The ancient sophists and writers of rhetorical handbooks had developed a concept of relevance that was very useful in analyzing the parts of a speech in which an argument was put forward. The use of the notion of *stasis* to define relevance came from Hermagoras. As shown in chapter 2, it was developed by Quintilian and Cicero, and applied to digressions in political speeches designed to advocate a course of action, and legal speeches to argue one side in a criminal trial in court. Although its usefulness for analyzing political and legal argumentation is obvious, this potentially useful idea of relevance never found its way into the mainstream logic curriculum as a basis for evaluating irrelevance in argumentation.

What place has relevance had in the logic curriculum over the centuries? Beginning with Aristotle, irrelevance was treated in logic textbooks and manuals under the heading of fallacies. Aristotle included ignorance of refutation (*ignoratio elenchi*) as a fallacy or sophistical refutation in his list of fallacies in *On Sophistical Refutations*. This account set the tradition that then persisted in logic for over two thousand years. Up to postmodern times, irrelevance survived on the fringes of the logic curriculum, in the textbook treatments of fallacies, as outlined in chapter 3. And Aristotle's account of fallacies was not improved upon. More often it was treated cursorily, in most instances almost unintelligibly—a lingering ghost of an ancient part of logic that was never really developed as a serious discipline. For Aristotle, dialectic was the logical counterpart of rhetoric. But although rhetoric survived, dialectic faded into obscurity after Aristotle. His theory of dialectical argument, the practical theory of argumentation needed to make coherent sense of this fallacy (and other fallacies) never caught on, or was developed as a subject in the mainstream of logic. It died out in the Middle Ages, eclipsed by the overwhelming success of his deductive logic of the syllogism, the semantic approach that dominated the medieval curriculum. And then deductive logic, made into a mathematical logic in the twentieth century, went on to dominate the modern curriculum. The concept of relevance did have some place in the

version of dialectic that was taught in the Middle Ages, but even that development died out before the modern period.<sup>1</sup>

## 1. ARISTOTLE ON MISCONCEPTION OF REFUTATION

Aristotle, in *On Sophistical Refutations* (166 b20), his book on fallacies, divided fallacies into two kinds—those connected with language and those not connected with language. He distinguished seven fallacies not connected with language (166 b21-26), and among these, the third was called “misconception of refutation” (or at least that is the term for this fallacy preferred by Hamblin, 1970, p. 32). To understand the fallacy, it is necessary to look at Aristotle’s definition (165 a1-4) of the term refutation (*elenchos*):

Reasoning (*sylogismos*) is based on certain statements made in such a way as necessarily to cause the assertion of things other than those statements and as a result of those statements; refutation, on the other hand, is reasoning accompanied by a contradiction of the conclusion (Forster p. 13).

The idea is that more is involved in refutation than just reasoning in the form of a syllogism or chain of syllogisms. Refutation is reasoning directed toward a specific proposition, with the aim of proving that proposition (the conclusion) to be false. This distinction leaves open the possibility that a refutation could fail for reasons other than its being an invalid syllogism. It could be faulty because it fails to refute a specific proposition designated as the conclusion to be refuted even though the reasoning in the refutation is made up of valid syllogisms.

This account of refutation leaves open the way for a fallacy of spurious or apparent refutation to occur in some cases. A chain of reasoning could be composed of a chain of valid syllogisms and could appear to refute the conclusion it is supposed to refute, but such an apparent refutation could fail to be a real or genuine refutation, for various reasons other than failure of validity of reasoning. It is precisely this type of failure that Aristotle defines (167 a22-36) as his third fallacy not connected to language, which has come to be known as the fallacy of *ignoratio elenchi*, or ignorance of refutation. The following is Hamblin’s translation of the key passage starting at 167 a22:

---

<sup>1</sup> This survey is far from complete. The history of the development of the idea of relevance in logic and rhetoric remains to be done. The purpose of this survey is to place the subsequent analysis of relevance in a historical perspective that will make it easier to understand and appreciate.

Other fallacies occur because the terms ‘proof’ or ‘refutation’ have not been defined, and because something is left out in their definition. For to refute is to contradict one and the same attribute—not merely the name, but the reality—and a name that is not merely synonymous but the same name—and to confute it from the propositions granted, necessarily, without including in the reckoning the original point to be proved, in the same respect and relation and manner and time in which it was asserted. . . . Some people, however, omit some one of the said conditions and give a merely apparent refutation, . . . (Hamblin, *Fallacies*, 87)

The meaning of this passage has puzzled commentators because, as Hamblin suggests, “there is an attempt here to set down complete conditions of valid ‘refutation’; that is, of ‘proof’” (Hamblin, *Fallacies*, 87). For example, the condition ‘without including in the reckoning the original point to be proved’ is meant to exclude the fallacy of begging the question. As Hamblin later noted (p. 105), Aristotle’s account of the fallacy of misconception of refutation just quoted encapsulates a virtually complete doctrine of fallacy. According to Hamblin’s reconstruction of this implicitly stated doctrine, a fallacy can be conceived as a refutation that fails for any one of the following nine reasons:

- i. the reality is not contradicted, but only the name, or
- ii. the proof contains only a ‘synonymous’ word, or
- iii. the premises of the refutation are not granted, or
- iv. are not necessary (but only accidental), or
- v. the original point to be proved is among the premises, or
- vi. the refutation does not refute in the same respect, or
- vii. relation, or
- viii. manner, or
- ix. time.

Each one of these failures and/or subgroups of them could be classified as a separate fallacy in its own right. For example, violating one or more of requirements vi. through ix. really amounts to committing the *secundum quid* fallacy. This fallacy is in fact the second of Aristotle’s list of seven fallacies outside language, defined as “the use of an expression absolutely or not absolutely but with some qualification of respect, or place, or time, or relation” (*On Sophistical Refutations* 166 b22-23). One of the examples given by Aristotle is the following inference:

The Ethiopian is black.  
 The Ethiopian has white teeth.  
 Therefore, the Ethiopian is black and not black. (167a77-15)

The conclusion is a contradiction, but the apparently incorrect inference can be resolved by rewriting the first premise to read, ‘The Ethiopian is black with respect to his skin color.’ Thus, the correct conclusion to draw is that the Ethiopian is black in one respect but is not black in another respect. Another resolution would be to rewrite the first premise to read, ‘The Ethiopian is black all over, that is, his skin color is black, so he is generally black with respect to the color of his body parts, but not without exception.’ Here too the contradiction is resolved because a person can be generally black, but yet be white in one particular respect, that is, one visible body part (the teeth, say) could be white. One can see then that Aristotle’s misconception of refutation fallacy includes his *secundum quid* fallacy as a subfallacy. The latter is a special instance of the former, more general fallacy, as Aristotle conceived his division of fallacies.

Small wonder, then, that the fallacy of *ignoratio elenchi* came to be a “rag-bag” category as it appeared in many of the logic textbooks through the ages. For there is plenty of textual justification, even in Aristotle’s own account of the fallacy, for conceiving it so broadly that it includes many, if not all, of the fallacies connected to language. Aristotle even goes so far as to add, at the end of his account of the fallacy of misconception of refutation, “One might, indeed, force this fallacy also into the category of those connected with language” (167 a35). So Aristotle admits that the fallacy of misconception of refutation could be stretched to cover all the other fallacies he cited.

Hamblin expressed the problem very pointedly when he wrote: “At this point it is clear that there is an overlap in the classification: Misconception of Refutation should have been confined to the cases not covered elsewhere” (88). The whole history of the subject of fallacies since Aristotle has been plagued by this problem, and it has never been solved. As we will see, the history of *ignoratio elenchi*, as a fallacy treated in logic textbooks over a period of two millennia and a half after Aristotle, is riddled with ambiguity, unclarity, and confusion, on the question of how various other fallacies are related to it.

Curiously, in another place (*Topica* 162 a13-16) Aristotle gave a quite clear and general account of the fallacy of misconception of refutation:

When the argument stated is a demonstration of something, but it is something irrelevant which has nothing to do with the conclusion, no inference will be drawn from it about the latter; if there appears to be such an inference, it will be a sophism not a demonstration.

In this definition of the fallacy of misconception of refutation, no mention is made of the complications introduced by considering the different specific ways the fallacy is committed. So the account is more general than that given in *On Sophistical Refutations*. A more literal translation (provided by Craig Cooper,

December, 1995) gives an even clearer idea of exactly what Aristotle is describing when the translator refers to “irrelevance”:

When the argument stated is a demonstration [*apodeixis*] of something, if it's something other than that leading to the conclusion, it will not be a syllogism about that thing.<sup>2</sup>

Here one gets the idea that the syllogism put forward can be valid, but the problem or fault is not the failure of validity. The problem is that the syllogism will not have the right proposition for its conclusion, namely, the proposition that is supposed to be demonstrated. The argument proves something, but not the right thing, that is, the thing that was supposed to be proved.

In other words, let's say that in the case in point, the conclusion that is supposed to be proved is proposition  $C_1$ . But then the argument stated, or actually put forward, is a valid syllogism (or more generally, a valid deductive argument) of the form ' $P_1, P_2, \dots, P_n$ , therefore  $C_2$ ' where  $C_1$  is not the same as  $C_2$ . Then the argument will be a valid argument (in Aristotle's terms *syllogismos*), but it will not be an argument “about that thing,” that is, about the conclusion that is supposed to be proved,  $C_1$ . But, as Aristotle adds, the inference could appear to be of the form, ' $P_1, P_2, \dots, P_n$ , therefore  $C_1$ ,' and hence the argument actually put forward could be a sophism. This kind of mistake could occur where  $C_2$  is similar to  $C_1$ , or where, for various reasons,  $C_2$  is easily confused (in the given context of the argument) with  $C_1$ . Here is a very clear account of the Aristotelian fallacy of misconception of refutation, which could also be called the fallacy of wrong conclusion.

## 2. THE ANCIENT CONCEPT OF STASIS

The *stasis* system found in the rhetorical manuals of antiquity is generally attributed to Hermagoras of Temnos (Hohmann, 1989, p. 172). Hermagoras was a professional teacher of rhetoric who lived about the middle of the second century B.C., and wrote a handbook (now lost) outlining the structure of speechmaking (Kennedy, 1963, p. 303). The structure of Hermagoras's book was a modification of a version common since Aristotle (Kennedy, p. 304), and Hermagoras's system remained current for approximately three centuries after it

---

<sup>2</sup> Another informative way to translate this passage, according to Craig Cooper, would be the following:

Where the argument stated is a demonstration of something, if it is anything not leading to the conclusion, it will not be a syllogism about that thing.

This translation will turn out to be particularly significant in light of the new dialectical theory of fallacies of irrelevance presented in chapter 7.



appeared (Nadeau, 1959, p. 71). The last of a series of philosophers and rhetoricians who revised the system of Hermagoras was Hermogenes of Tarsus, a Greek rhetorician of the second half of the second century A.D.. Hermogenes wrote a series of manuals or textbooks on rhetoric that were used widely as schoolbooks through the middle ages and into the Renaissance (Nadeau, 1964, p. 363). An account of the system of Hermagoras was given in the *Institutio Oratoria* of Quintilian (Marcus Fabius Quintilianus, circa A.D. 35-99, a rhetorician and pleader in the courts at Rome). From Quintilian's account (trans. H. E. Butler in the Loeb Library Edition), it is possible to grasp clearly how the system of Hermagoras expressed a pragmatic concept of relevance of argumentation.

According to Hermagoras, the task of the orator was to "treat proposed political questions as persuasively as possible." However, by "political questions" he meant anything that involved a citizen, including deliberations, ethical discussions, traditional public oratory, pleading in a court, and philosophical discussions related to political life (Kennedy, 1963, pp. 304-305). Quintilian (*Institutio Oratoria* III. 4. 15-16) includes deliberative oratory (concerning what is expedient) and forensic oratory (concerning what is just) among the kinds of speeches to which the system of Hermagoras is applicable.

The basic idea in the structure of Hermagoras was that in any extended sequences of argumentation in a speech of the kind he was concerned with, the speech as a whole must have some question it was meant to answer or reply to, some controversy it was meant to address, or some problem it was meant to solve or consider. This originating basis of the argumentation was called the *stasis*, in Greek, or *status*, in Latin, of the speech. Quintilian (*Institutio Oratoria* III. 4. 2-4; Butler, 1920, vol. I, p. 409) explained that several different terms have been used for this concept.

That which I call the *basis* some style the *constitution*, others the *question*, and others again that which may be inferred from the *question*, while Theodorus calls it the most *general head*, *kefalaion genikwtaton*, to which everything must be referred. These different names, however, all mean the same thing, nor is it of the least importance to students by what special name things are called, as long as the thing itself is perfectly clear. The Greeks call this essential basis *stasis*, a name which they hold was not invented by Hermagoras, but according to some was introduced by Naucrates, the pupil of Isocrates, according to others by Zopyrus of Clazomenae, although Aeschines in his speech against Ctesiphon seems to employ the word, when he asks the jury not to allow Demosthenes to be irrelevant but to keep him to the *stasis* or *basis* of the case. The term seems to be derived from the fact that it is on it that the first collision between the parties to the dispute takes place, or that it forms the *basis* or *standing* of the whole case.

What Quintilian called the *stasis* or *basis* of a case is what we would nowadays call the issue or point of contention that the whole sequence of argumentation in the case is supposed to be about. The example he uses of Demosthenes pleading a case in court indicates clearly how *stasis* ties in with the concept of relevance. Aeschines asks the jury “not to allow Demosthenes to be irrelevant, but to keep him to the *stasis* or *basis* of the case.” Relevance is keeping to the *stasis* and irrelevance is getting away from the *stasis*.

It is significant that Quintilian referred to a legal case to illustrate *stasis*. The system of Hermagoras was developed primarily with legal disputes in mind (Hohmann, 1989, p. 172). The standard kind of case used to illustrate *stasis* was that of the different kinds of *stases* or points at issue in a criminal trial (Kennedy, 1963, p. 306).

In any litigation there are several possible points which could be the significant point at issue between the disputants and the real basis of the court’s decision. Thus, when charged with theft a defendant may deny the fact of having taken the property, or he may admit the act but deny the definition of that act as stealing (perhaps the property was his own), or he may admit the fact of theft but allege some justification (he stole a dagger from the hands of a mad man), or finally, he may deny the right of the opponent to prosecute him or the competence of the court (perhaps, as Aeschines alleged of Timarchus, the prosecutor has lost his civil rights).

From these examples, it can be seen that a *stasis* is a pair of propositions, one of which is opposed to the other, and there is controversy over which proposition is true, as opposed to the other. For example, a defendant is charged with theft so his accuser is claiming that he (the defendant) stole the property in question. The defendant denies this accusation. That is, he claims that the proposition that he stole the property is false. This example represents a typical *stasis* or issue—one party maintains that a particular proposition is true, while the other maintains that this proposition is false.

Generally then, a *stasis* or issue involves three elements: a pair of propositions, a relation of opposition between those propositions, and two participants in a dialogue, each of whom maintains one of these propositions. In the legal case above, the conflict of opinions is about whether a particular proposition is true or not. But in the context of a deliberation, the *stasis*—the problem, issue, or conflict—could be about which course of action is right (or best to go ahead with in the circumstances). Even more generally, it can be stated that an argument involves a context of dialogue based on an issue or *stasis*. The issue is what the dialogue is supposed to be about. And any particular argument used in that context of dialogue will be relevant to the extent that it relates to that issue.

### 3. IRRELEVANCE AND DIGRESSION

Quintilian, in the *Institutio Oratoria*, bases his conception of irrelevance on the framework of a speech, or context of dialogue, having a number of ordered stages. For example, in a forensic argument about a particular issue, like whether a defendant has committed a particular crime or not, there are four stages in the argument (IV. 2. 6-7). There is an *exordium* or preliminary stage, a statement of facts stage, a cogency of proofs stage, and a peroration stage, where the facts are recapitulated for the judge, or his emotion is stirred up. Certain types of arguments, or moves made in the speech are appropriate for each of these stages. A speech can be seen as a Gricean conversational exchange insofar as the speaker anticipates and replies to the reactions of the audience. Quintilian's theory is pragmatic in nature, being based essentially on the Gricean principle (see chapter 6) that the participants are contributing at different stages to a collaborative conversation.

Once this framework of a sequence of ordered stages is set in place for any type of conversational exchange, whether it be a criminal trial, a philosophical discussion, or a deliberation on what to do, like a town hall meeting, then any move made at any stage of the speech that deviates from the appropriate types of moves for that stage of the speech, can be judged irrelevant. Irrelevance then is defined as any kind of digression away from the proper line of argument appropriate for a particular stage of a speech, or dialogue framework of argumentation. But irrelevance is determined by another factor, as well as the sequence of the stages of the unfolding dialogue. It is also determined by the issue or *stasis* of the dialogue. Whatever does not bear on the issue, by not being an appropriate move in the sequence of dialogue—which, after all has the basic purpose of resolving the issue one way or the other, by producing arguments that bear on it—is judged irrelevant.

Quintilian (*Institutio Oratoria* IV. 3. 15-16) defined anything that falls outside of the sequence of stages for a given speech (here he numbered five stages) as a digression (*egressio*).

For whatever we say that falls outside the five divisions of the speech already laid down is a digression, whether it express indignation, pity, hatred, rebuke, excuse, conciliation or be designed to rebut invective. Other similar occasions for digression on points not involved by the question at issue arise when we amplify or abridge a topic, make any kind of emotional appeal or introduce any of those topics which add such charm and elegance to oratory, topics that is to say such as luxury, avarice, religion, duty: but these would hardly seem to be digressions as they are so closely attached to arguments on similar subjects that they form part of the texture of the speech. There are however a number of

topics which are inserted in the midst of matter which has no connexion with them, when for example we strive to excite, admonish, appease, entreat or praise the judge. (129)

Very clearly expressed here is the idea that different kinds of emotional appeals—to pity, indignation, hatred, and so forth—can be judged to be digressions on the grounds that they are not involved in the question at issue (*stasis*). Moreover, Quintilian clearly stated that such digressions can be misleading, and can appear to be relevant, because they are “so closely attached to arguments on similar subjects that they form part of the texture of the speech.” In fact, they may even be “relevant” in some broad sense, but nonetheless they are irrelevant, or digressions, in some narrower sense of the meaning of these words that is very important for judging the argumentation in a speech.

Quintilian was very well aware then that using digression in a speech can have a rhetorical effect in securing the favor of an audience. He wrote, “Most [rhetoricians] are in the habit, as soon as they have completed the *statement of facts*, of digressing to some pleasant and attractive topic with a view to securing the utmost amount of favour from their audience” (*Institutio Oratoria* IV. 3. 1-2). By introducing such a declamation, the orator makes his speech more pleasurable to the audience or judge, and makes it seem less “flat” or “pugnacious” (IV. 3. 2). Thus Quintilian was quite aware of the possibility of using a digression in a rhetorically clever way, so that it may not only appear to be relevant, but may even have quite a persuasive effect as part of a speech, even though the argument or declamation is not really relevant in the narrower sense of contributing to the evidence needed to bear logically on the issue or *stasis* of the dialogue.

The original motivation to study irrelevance in legal argumentation came from the textbook example of Copi cited in chapter 1, section 3. In case 1.3, the lawyer in a murder case argued at length that murder is a horrible crime. Interestingly, case 1.3 as representing the use of a sophisticated tactic of digression in pleading a case in court was known to the ancient world. Quintilian, in *Institutio Oratoria* (IV. 3. 1-12) discussed this very case at some length. Quintilian’s discussion is mainly concerned with the rhetorical effect such a digression on the horribleness of murder would have, when used as an argument tactic to sway a jury against a defendant accused of murder. But his discussion of whether the prosecutor’s argument is relevant or not is highly subtle and informative. As will be shown in chapter 4, it far surpasses any treatments of this kind of case that have appeared in twentieth-century treatments of the *ignoratio elenchi* fallacy.

Quintilian began his discussion by observing that rhetorical speakers have a habit, as soon as they have reached the stage in their speech of stating the facts (the statement of facts stage), of “digressing to some pleasant and attractive

topic” to win the favor of the audience (IV. 3. 2). Making pleas in court would be the leading kind of context of this kind of speechmaking. According to Quintilian, such rhetorical speakers transfer some “striking thoughts” which should properly have a place elsewhere in the speech to the part of the speech where the statement of facts is supposedly being made (IV. 3. 3). Quintilian calls this tactic a digression (IV. 3. 4), noting that it can confer “great distinction and adornment on a speech” if it fits in naturally with the result of it, and is not “thrust in like a wedge parting what should naturally come together” (IV. 3. 4-5). So the following general problem is posed. When is such a digression legitimate, and when is it inappropriate? Actually, there are two questions. When is such a digression advantageous in persuading a judge or jury? And when is such a digression appropriate or relevant in the logical sense, or the narrower sense of throwing light on or contributing to the relevance of the issue that is supposed to be the basis (*stasis*) of the case?

Quintilian’s commentary on how to approach this sort of problem is well worth a close look. He cited a legal case where a defendant has been charged with murder, and the prosecutor has just reached the stage of the trial where the statement of facts is being concluded, and the next stage is beginning. At this next stage—the so-called cogency of proofs stage—the arguments of the two sides are put forward, and each side questions or tries to refute the arguments of the other side (*Institutio Oratoria* IV. 3. 5). Quintilian wrote “there is no part of a speech so closely connected as the *statement* with the *proof*” (IV. 3. 6), so just at this transition point in a trial, there can be room for a digression.

There will therefore sometimes be room for digression; for example if the end of the *statement* has been concerned with some specially horrible theme, we may embroider the theme as though our indignation must find immediate vent. This, however, should only be done if there is no question about the facts. Otherwise it is more important to verify your charge than to heighten it, since the horrible nature of a charge is in favor of the accused, until the charge is proved. For it is just the most flagrant crimes that are the most difficult to prove.

Quintilian’s judgment is very careful here. A digression about the horrible nature of the charge could have a useful function of venting indignation, even if it is a digression from the main issue of the trial. But he adds that it should only be done “if there is no question about the facts.” Otherwise the digression could backfire, since a more horrible crime might be more difficult to prove—for example, if the opposing pleader could show that the defendant’s character would not be consistent with his committing a horrible crime. Quintilian adds that any such digression should also be brief (IV. 3. 8), and care must be taken not to weary the court by useless delay which might divert the minds of the court and nullify the effects of one’s own statement of facts (IV. 3. 9).

Cicero, in the *De Inventione* (I.LII.99-100), described several stages that the speech of the prosecuting attorney in a criminal trial can have. One stage he describes, which occurs toward the end of the speech, is called the *indignatio*, “a passage which results in arousing great hatred against some person, or violent offense at some action” (*De Inventione* I. LIII.100; p. 151 of Hubbell’s translation). According to Cicero, the *indignatio* has a broad range of topics that may be covered, including any method of arousing enmity against the defendant. Among the possible topics he includes in the *indignatio* are the question of “what would happen if everyone acted the same way, and whether if he gets away with this crime, many others will emulate his career of crime.” The *indignatio* as a type of argumentation used in the summing up stage of a prosecutor’s argument in a criminal trial, is surely also a familiar enough feature of contemporary legal argumentation.

According to Jonsen and Toulmin (1988, p. 86), the *indignatio* comes at the end of the speech, and its function is to arouse hatred or disgust toward the accused or her actions. Part of the *indignatio* repeats briefly and forcibly the arguments already covered in the *confirmatio* section of the speech, where the evidence showing the guilt of the accused was presented. And one topic covered in the *indignatio* (p. 86), is that of comparison with other acts “commonly regarded as dishonorable or unjust.” According to this description of the *indignatio* as part of a legal speech in a courtroom trial, an argument advocating the proposition, ‘Murder is a horrible crime.’ would have a place in the *indignatio* part of the speech, and therefore would be dialectically relevant in the trial as a whole. In short then, everything depends on the exact place of the digression in the sequence of stages in the case, and how long the digression is. A short and timely digression at just the right juncture in the case could be useful in disposing the judge to take a more favorable view of one’s argument. But a clumsy or lengthy digression could harm one’s case and interrupt the flow of a speech. Quintilian concludes (IV. 3. 14) that what the Greeks call a *parekbasis* and the Romans call a *digressio* (digression) can have some bearing on a case “in a passage that involves digression from the logical order of our speech.” Thus Quintilian’s and Cicero’s discussions of ancient styles of pleading very much parallel the twentieth-century analysis of legal relevance given by Roberts (1993). Both ancient and modern discussions show that whether or not an argument is relevant really depends on how it is supposedly used in a particular way to fit in with a particular line of argument that is supposedly connected to the issue of the case. The point is basically the same in legal and non-legal cases. An argument is really only relevant in a case, in the most important sense, if it is materially relevant in fitting into some particular line of argument used to squarely meet the issue of the case.

The notion of digression, as outlined by rhetoricians in the ancient world like Quintilian, provided a dialectical structure in which the concept of relevance could be understood and defined in relation to the purpose of a

speech. However, for the most part, such notions were not taken up by logicians, therefore they never became part of the core logic curriculum. One partial and possible exception was the so-called obligation game in the Middle Ages, a kind of verbal game used for instruction on reasoning in the classroom, and designed to model logical disputation between two parties, one of whom is supposed to defend a designated thesis. Here the notion of relevance survived, at least in an attenuated form. Relevance also continued to be treated in its Aristotelian form in those parts of the textbooks covering the fallacies.

#### 4. WILLIAM OF SHERWOOD ON *IGNORATIO ELENCHI*

From Aristotle's own time until the twelfth century, his *Topics*, *Prior and Posterior Analytics*, *Rhetoric* and *On Sophistical Refutations* were "for practical purposes, unavailable in Europe" (Hamblin, 1970, p. 104). With the rediscovery of these lost works, the Aristotelian list of fallacies (sophistical refutations) began to appear in logic textbooks, often quoted directly from Aristotle, with some commentary or explanation given. Hamblin (1970, chap. 3) presented a useful survey of these developments. The works of this rediscovery period, according to Hamblin (p. 115), "all deal with nearly the same material, and give tightly interlocking treatments of it." To illustrate this treatment, Hamblin picks William of Sherwood as typical, and on the concept of relevance, William's account will also serve very well in our outline. Not much is known about William's life. He was born in England between 1200 and 1210, and taught, with other distinguished logicians, at the University of Paris in the 1240s (Hamblin, 1970, p. 116).

In William of Sherwood's *Introduction to Logic*, under the heading 'Sophistical Reasoning,' there is a section on the fallacy of Ignorance Regarding Refutation (William of Sherwood, 1966, pp. 155-157). William began by repeating Aristotle's definition of refutation, and his account of the *ignoratio elenchi* as a fallacy follows that of Aristotle in *On Sophistical Refutations* quite closely. The general problem that William struggled with—a problem implicit in Aristotle's account—is that of attempting to separate the general fallacy of *ignoratio elenchi* from the subfallacies contained within Aristotle's account of it.

William began by stating that Aristotle's definition of refutation has four aspects (p. 155):

A refutation is a contradiction of one and the same [predicate], not of the name alone but of the thing together with the name, and not of a synonym but of the very same name, on the basis of the stated [premisses] and [following] necessarily from them (without including in them what was in the original point to be proved)—[A] in the same

respect, [B] in the same relation, [C] in the same way, and [D] at the same time.

Then he went on to cite the problem discussed in section 1 above, namely, that there can be several different fallacies of ignorance regarding refutation, depending on which one of these requirements or parts of the refutation is missing in a given case (pp. 155-156):

There are then four paralogisms depending on the omission of these four parts. In connection with [A] as follows: 'a is twice as great as b in length and is not twice as great as b in width; therefore it is both twice as great and not twice as great.' In connection with [B] as follows: 'a is twice as great as b and is not twice as great as c; therefore it is both twice as great and not twice as great.' In connection with [C] as follows: 'Socrates is naturally pious but he is not absolutely pious; therefore he is both pious and not pious.' In connection with [D] as follows: 'Socrates is running at [time] a (*currit in a*) and he is not running at [time] b; therefore he is both running and not running.' There is Ignorance Regarding Refutation in these four paralogisms because [in each of them] a contradiction seems to be concluded but is not [really] concluded, for [in each of them] one of those four parts is missing.

William went on to deal with this problem in pretty much the way outlined in section 1 of this chapter. He conceded that all four paralogisms could be considered instances of the fallacy of *secundum quid*—he calls this fallacy "In a Certain Respect as Well as Absolutely"—but nevertheless, he insists, the underlying more general fallacy, in all cases [A], [B], [C] and [D], is ignorance of refutation. William insisted that the underlying problem is one of a failure of refutation in Aristotle's sense, even though, along the way, the paralogisms [A], [B], [C] and [D] also involve *secundum quid* in the Aristotelian sense of neglect of qualifications.

One can see that William was grappling with the basic problem posed by Aristotle's treatment of the fallacy of misconception of refutation, and trying to judiciously balance the difficulties inherent in Aristotle's account. He was doing his best to remain true to Aristotle's account, for the dialectical nature of his examination of the problem shows a certain ambivalence. First he posed the problem—are these four paralogisms cases of "ignorance regarding refutation" or "in a certain respect" (*secundum quid*)? Then he offered his reply to this question (p. 156).

In reply we must point out that there is nothing in those paralogisms preventing them from being [considered] cases of erring [as a result of using a locution] In a Certain Respect as Well as Absolutely. But that is



not the main issue (*causa principalis*). The difference between Ignorance Regarding Refutation and [using a locution] In a Certain Respect as Well as Absolutely is that the latter does not aim at concluding a contradiction, as was shown earlier, although in solving it it is necessary to consider the conclusion in relation to its contradiction. In Ignorance Regarding Refutation, even though some determination is involved, still the aim is to conclude a contradiction absolutely. In that way these paralogisms differ from those that are [based on using a locution] In a Certain Respect as Well as Absolutely.

In the end, William's solution proves to be the only way to make sense of Aristotle's classification of fallacies in *On Sophistical Refutations* (as will be shown in chapter 7). But it certainly introduces subtleties that might be hard to explain and defend in textbook treatment of fallacies intended for use with undergraduates at universities, or generally with beginners in the field of logic. For to say that the paralogisms [A], [B], [C] and [D] are cases of the fallacy of *secundum quid*, but then are also, at a more general or underlying level, also cases of *ignoratio elenchi*, could prove confusing and controversial. Undergraduates want a clear and definite way of classifying fallacies—so that if a case is given on a test, there is a method of determining whether one fallacy or another has been committed. Some borderline cases are acceptable, if they can be dealt with decisively, but to say that in many cases one fallacy overlaps systematically with another, at a deeper level, is disturbing to those who want to implement clear and precisely accountable differences between cases of different fallacies. The confusion surrounding the nomenclature and classification of the *secundum quid* fallacy has already been documented in Walton (*Arg. Schemes*, 1996, chapter 5). It may not come as such a big surprise to find subsequently that the treatment of the *ignoratio elenchi* fallacy in the twentieth-century logic textbooks can be described as a conceptual disarray, mixing several fallacies together in ways that make it hard to separate them.

## 5. THE OBLIGATION GAME

The medieval obligation game, described succinctly by Hamblin (1970, pp. 126-134), was an offshoot of Aristotelian dialectic. It was a formalistic (precisely regulated) type of game in which syllogistic reasoning was used. However, it involved question-reply conversational exchanges, giving it a pragmatic character of sorts. The obligation game developed a formalistic way of modeling the concept of relevance in argumentation. Obligation was played by two participants, called the *opponent* and the *respondent*. The respondent had the task of upholding a thesis called the *positum*, and the opponent had the task of putting yes-no questions to the respondent. The opponent's goal was to try to

trap the respondent into conceding a contradiction. The respondent's goal was to survive answering the questions without being trapped into a contradiction.

As Hamblin indicated in his outline of the obligation game (p. 127), the *positum* was usually a false proposition like 'Socrates is black.' The respondent, therefore, had to be prepared to defend other falsehoods (or propositions he is not really committed to) in order to maintain consistency. But he was also expected to tell the truth if that did not contradict any of his earlier concessions. So if the respondent had 'Socrates is black' as his *positum*, and he was asked 'Is Plato black?', he would be expected to reply, 'No.' But if he had previously conceded the proposition 'Socrates and Plato are the same color,' then he would have to reply, 'Yes' to the question 'Is Plato black?' (or lose the game).<sup>3</sup>

The obligation game grew out of the medieval teaching system, which involved the reading and explanation of set texts, and discussions arising out of difficulties posed by interpretation of a text (Green, 1963, p. 3). This technique, reinforced by the rediscovery and introduction into the curriculum, in the twelfth century, of Aristotle's *Topics* and *On Sophistical Refutations*, led to the medieval method of disputation (*disputatio*). The *disputatio* was the stage reached where controversial general propositions of all sorts were questioned and disputed by looking at the arguments on both sides of an issue. The philosophical method of Aquinas is perhaps the best-known medieval example of the use of the technique of discussing an issue by systematically examining questions, objections, and replies in sequence.

The obligation treatise modeled the disputation at a more abstract level, for the purpose of giving a student exercises in logical reasoning, using the obligation game as the structure of the exercises. According to Hamblin (1970, p. 126), one of the earliest—and perhaps the earliest—of the obligation treatises, is ascribed to William of Sherwood. Hamblin also notes that there are no extant treatises earlier than the time of William, although several dozen obligation treatises from the fourteenth century or later are known (p. 126). Hamblin's analysis of William's version of the obligation game (pp. 260-263) shows that William's treatise is an important contribution to the formal analysis of pragmatic structures.

The obligation game was in many ways an abstract and artificial model of realistic disputation of the kind one would expect, for example, in a philosophical or theological discussion of a controversial issue. For the *positum* was not generally a proposition that the respondent believed, or was committed to. And the opponent could put any yes-no question to the respondent, even where the proposition queried was irrelevant to the *positum* and bore no relation to any other propositions featured in the previous dialogue exchanges.

---

<sup>3</sup> Hamblin (1970, pp. 260-263) presented a simple formalized version of the obligation game that represents the essence of the game very well.

Even so, there was a certain notion of relevance, which seems more dialectical in nature than semantic, that could be modeled in the obligation game. The most important thing for the respondent was to always maintain consistency with the *positum*, and with the propositions he had conceded in previous replies to the opponent. But the opponent could also put these propositions together and draw conclusions from them, using logical rules of inference, like syllogisms. So the respondent had to try to look ahead, and not be trapped into inconsistency by conceding any proposition that could be used, in conjunction with the *positum* or previously conceded propositions, to generate a contradiction by a sequence of inferences, putting any of these propositions together as premises. What was very important for the respondent to be sure of then, before answering on the basis of what he thought was really true or not, was whether an answer given would supply such a useful premise. That is, a premise that could be used, in conjunction with his *positum* and previous concessions, to generate a contradiction as an outcome of a sequence of inferences. So any proposition could be described as “relevant” that bears any sort of logical relationship to the set of propositions conceded earlier in the game (including the *positum*). ‘Relevant’ here means something like “potentially useful to refute the opposing player.”

According to Green (1963, pp. 53-54), just such a concept of relevance is defined in William of Sherwood’s obligation treatise. This definition concerns the *proposita*, the propositions that are proposed and/or accepted at different moves as the game proceeds.

*A propositum* has, in general, one of two possible relationships with the *positum* and/or with other *proposita*: either it stands in a logical relationship with these, i.e. it is *pertinens*, or it has no logical relationship with these, i.e. it is *impertinens*. Further, a statement that is *pertinens* is one either that logically follows from what precedes, i.e. it is *sequens*, or that is logically repugnant to what precedes, i.e. it is *repugnans*. Sherwood also precises that, for a statement to be *pertinens*, it may have a logical relationship with the *positum* and other *proposita* either singly or taken together—*coniunctim vel divisim*; but the statement that is *impertinens* must have no relationship to anything that has gone before—it is to be considered *coniunctim tantum* (Green, 1963, pp. 53-54).

The concept of relevance modeled here is implicitly a dynamic notion, because a particular proposition is held to be relevant at any particular point in the development of the series of moves in the game if it follows from or is inconsistent with any (or any collection) of the propositions that have figured in previous moves of the game. Because it requires a dynamic context, relevance as defined here has a conversational nature. A proposition is relevant if and only if it is pertinent, in William’s sense, in the context of some implicit game or

framework of dialogue wherein the opponent and respondent are making a sequence of moves, according to the rules of the game. The game provides a sort of context of conversation even though it is an artificial one, and the sense of relevance is explicitly propositional and only implicitly dialectical.

This dynamic concept of relevance, expressed in relation to the structure of the obligation game, is, in broad outline, similar to Aristotle's framework of dialectical argument (as it was meant to be). It also bears a general structural similarity to the idea of an organized speech, as outlined by Hermagoras, as a framework of dialogue exchange in which a move in argument can be judged to be relevant or irrelevant. The obligation game, then, showed all sorts of promise as a structural framework in which a dialectical concept of relevance could be clearly and usefully defined for purposes of evaluating arguments logically. Unfortunately, it died out, falling into nearly complete obscurity in the logic curriculum even before Enlightenment thinkers like Pascal and Descartes came to see mathematical reasoning, exemplified by Euclidean geometry, as the model of all reasoning that is important for logic. Along with this way of thinking came the modern treatment (or mistreatment) of fallacies.

## 6. THE PORT ROYAL LOGIC

*The Art of Thinking* (1662), frequently called *The Port Royal Logic*, written by Antoine Arnauld with the help of Pierre Nicole and other members of the Port Royal Movement in Paris, is a logic book that has been very influential in the development of modern treatments of fallacies. As Hamblin puts it (p. 148), the *Port Royal Logic* is "remarkably modern" for a book that is over three hundred years old. On the other hand, as Hamblin also notes (pp. 149-150), "its modernity is two-edged," for in it are found the origins of the "misinterpretations and inconsistencies" characteristic of the standard treatment of fallacies in modern logic textbooks.

Arnauld (1964, p. 246) began his account of the *ignoratio elenchi* fallacy by giving a very un-Aristotelian definition of it. In fact, what Arnauld described as the *ignoratio elenchi* fallacy looks much more like what would nowadays be called the *straw man fallacy*, as described in chapter 1. On the other hand, the fallacy Arnauld described (p. 246) seems to have some genuine connection with the Aristotelian fallacy of misconception of refutation.

The first sophism is proving something other than what is in question. Aristotle called this sophism *ignoratio elenchi*, an ignorance of what must be proved to an adversary. This sophism occurs commonly in the disputes of men, who argue hotly, often without understanding each other. A man is led by strong feeling or bad faith falsely to impute to an adversary opinions easily refuted or to force on the adversary even those

consequences of his doctrine which he disclaims or denies. Such sophistical maneuvers must be avoided at all cost by the good and sincere man.

Imputing to an adversary opinions that are not really his own, and then using the imputed opinions to refute the adversary by drawing consequences from them that go against the adversary's side, is the kind of argumentation nowadays called the straw man fallacy. Yet one can see how such an argument would be a sophistical or misconceived refutation in Aristotle's sense. So Arnauld's account of *ignoratio elenchi*, rather cleverly in a way, throws the reader off the track, turning Aristotle's fallacy of misconception of refutation in a different direction while retaining some elements of the Aristotelian fallacy.

The result of Arnauld's one-page treatment of the *ignoratio elenchi* fallacy is a hilarious attempt to turn the table on Aristotle by accusing the philosopher of committing this fallacy himself (pp. 246-247). Aristotle is portrayed as a dishonest arguer who treated his predecessors as "country bumpkins" (p. 246):

We wish Aristotle, who took such pains to alert us to this defect, had taken as much care to avoid it himself. It cannot be denied that in arguing against several of his predecessors he was a bit dishonest in his statement of their positions. He reproaches Parmenides and Melissus for having admitted only a single principle of all things. Then Aristotle goes on to argue against these philosophers as if they had held that all things are composed of this one principle, whereas for Parmenides and Melissus this unique principle was that from which all things take their origin—namely God.

This feisty attack on Aristotle's intellectual honesty continues for another two paragraphs and then abruptly, Arnauld's treatment of *ignoratio elenchi* ends. The way was now open to interpret the fallacy of misconception of refutation in quite a different way from how others had (more plausibly) interpreted it. And the way was open to confuse it with the straw man fallacy.

Unfortunately, this careless and eccentric interpretation of Aristotle's account of the *ignoratio elenchi* fallacy foreshadowed what was to become the modern treatment of relevance in twentieth-century logic textbooks. What happened was that the modern viewpoint lost all sight of the Aristotelian or Hermagorean type of dialectical framework of disputation—in which there is an issue (*stasis*), or proposition to be refuted by an argument—viewing an argument instead in a purely "objective" way as a set of propositions. Formal deductive logic, building on the Aristotelian theory of syllogistic and developments of the propositional logic of the Stoics, was to become the modern model of all reasoning that is centrally important in logic. Any

conversational framework of evaluating arguments as part of a dialogue exchange between two parties reasoning together would become an obscure notion, regarded as “subjective” or even incoherent, and certainly one that has no place of importance in the logic curriculum.

The outcome was that the fallacies of relevance remained on the fringes of logic. Textbook authors felt free to impose their own interpretations on them, while at the same time treating them briefly, and passing quickly to more important matters. Curiously, the Aristotelian terms (or their Latin counterparts), like *ignoratio elenchi*, remained in the textbooks. Modern students, however, would have no conception at all of what something called “ignorance of refutation” really amounts to as a fallacy because they would not have (nor would they be provided with) any systematic language or conversational framework in which such an expression would make coherent sense.

However, before going on to the twentieth-century treatment of *ignoratio elenchi*, we will examine three subsequent historically influential textbooks that tried, with varying degrees of success, to make sense of this Aristotelian fallacy. In all three instances, the attempts to give examples that would make sense to a modern student are of interest in their own right.

## 7. ISAAC WATTS’S LOGICK

There were very few logic books written in the eighteenth century. An exception, Isaac Watts’s *Logick*, first published in 1725, had a lasting influence on subsequent logic textbooks. The very first of the list of sophisms (fallacies) dealt with in *Logick* (revised edition, 1797, pp. 280-281) was *ignoratio elenchi*. Watts (1797, p. 280) defined this fallacy as “a mistake of the *question*” that is committed “when something else is proved which has neither any necessary connexion or consistency with the thing inquired, and consequently gives no determination to the inquiry, though it may seem at first sight to determine the question.” This account seems somewhat Aristotelian in spirit, but the words used to set up the framework for the fallacy have shifted. The dialectical context now envisaged is that of an inquiry, a procedure of cumulative questioning or investigation that will be explained in chapter 5. The thing inquired into is called the “question” by Watts. The fallacy is then one of “mistaking the question,” where “something else is proved” that is not connected to or consistent with the question, and consequently the line of proof “gives no determination to the inquiry.” This account sounds generally, in outline, somewhat like the Aristotelian account of the fallacy of misconception of refutation, but the terms of reference have changed. Now the fallacy is one of proving the wrong proposition—a proposition that does not match up with the proposition that is supposed to be determined by the inquiry. Here, the concept of an inquiry performs the function of a context of dialogue in which the purpose is the

investigation of a designated question.<sup>4</sup> The fallacy is committed by an argument that “may seem at first sight to determine the question” but really does not.

Watts (p. 280) gives two examples to illustrate the fallacy of *ignoratio elenchi*:

**Case 2.1:** As, if any should conclude that St. *Paul* was not a *native Jew*, by proving that he was born a *Roman*: or if they should pretend to determine that he was neither *Roman* nor *Jew*, by proving that he was born at *Tarsus* in *Cilicia*, these sophisms are refuted by shewing that all these three may be true; for he was born of *Jewish parents* in the city of *Tarsus*, and by some peculiar privilege granted to his parents, or his native city, he was born a denizen of *Rome*. Thus there is neither of these three characters of the apostle inconsistent with each other, and therefore the proving one of them true does not refute the others.

**Case 2.2:** Or if the question be proposed, *Whether the excess of wine can be hurtful to him that drinks it*, and the sophister should prove that it revives his *spirits*, it exhilarates his *soul*, it gives a man *courage*, and makes him *strong* and *active*, and then he takes it for granted that he has proved his point.

But the respondent may easily shew, that though wine may do all this, yet it may be *finally hurtful both to the soul and body of him that drinks it to excess*.

The first case seems like a good example to illustrate some sort of fallacy, and it can be brought fairly well into line with Watts’s account of the *ignoratio elenchi* fallacy. But the second case is a classic case of Aristotle’s *secundum quid*, the fallacy of overlooking qualifications. Here we again run up against the tendency, implicit in Aristotle’s own account of the fallacy of misconception of refutation in *On Sophistical Refutations*, to be unclear about the dividing line between *ignoratio elenchi* and *secundum quid*.

If we disregard case 2.2 as an unfortunate example, Watts’s account so far does not seem to be too bad. Case 2.1 seems to illustrate how proving one proposition might seem to refute another when it really doesn’t. So an argument that seems at first sight to determine the question really does not, but rather proves something else instead. Unfortunately, however, Watts went on to give another general description of the *ignoratio elenchi* fallacy (pp. 280-281) that goes in yet another direction:

---

<sup>4</sup> See the normative model of the inquiry as a type of dialogue presented in chapter 5, below.

*Disputers* when they grow warm, are ready to run into this fallacy: they dress up the opinion of their adversary as they please, and ascribe sentiments to him which he does not acknowledge; and when they have with a great deal of pomp attacked and confounded these images of straw of their own making, they triumph over their adversary as though they had utterly refuted his opinion.

This account of the *ignoratio elenchi* fallacy reads very much like Arnauld's. In fact, it is revealing to observe that Watts even uses the expression, "images of straw of their own making." Both the description and the terminology strongly suggest what is now called the straw man fallacy. It is possible that this passage in Watts' *Logick* is, in fact, the origin of the use of the term 'straw man fallacy' in the logic textbooks.

Of course, as shown in chapter 1, the straw man fallacy is closely related to the Aristotelian fallacy of misconception of refutation, and Watts's parting comments (p. 281) do show that there is a genuine and close relationship here:

It [*ignoratio elenchi*] is a fallacy of the same kind which a *disputant* is guilty of, when he finds that his adversary is too hard for him, and that he cannot fairly prove the question first proposed; he then with slyness and subtlety turns the discourse aside to some other kindred point which he can prove, and exults in that new argument wherein his opponent never contradicted him.

The way to prevent this *fallacy* is by keeping the eye fixed on the precise point of dispute, and neither wandering from it ourselves, nor suffering our antagonist to wander from it, or substitute any thing else in its room.

In this passage, Watts is commenting on the fallacy described in the previous paragraph (quoted just above), which, in my opinion, is really the straw man fallacy. But he slips back into the language of *ignoratio elenchi* by citing the fallacy as a failure to "fairly prove the question first proposed." Then, he suggests that the way to prevent the fallacy is to keep "the eye fixed on the precise point of dispute." All this terminology suggests the Aristotelian fallacy of misconception of refutation.

Both Watts and Arnauld saw what came to be called the straw man fallacy as indistinguishable from the *ignoratio elenchi* fallacy. This overlap became an acute problem in the twentieth-century treatment of fallacies, where the straw man was generally (although not always) seen as a distinct fallacy in its own right (see chapter 3). The problem, then, was how this new fallacy was connected, if at all, with the *ignoratio elenchi* fallacy. One textbook author who had an unusually comprehensive grasp of both logic and rhetoric, and the history of both fields, was Richard Whately (1787-1863), who taught logic at Oxford and was later Archbishop of Dublin.



## 8. WHATELY'S ELEMENTS OF LOGIC

Whately's *Elements of Logic* (1826) gave an unusually clear and helpful account of the *ignoratio elenchi* fallacy, which Whately called the fallacy of irrelevant conclusion (9th ed., 1826, pp. 139-140):

Various kinds of propositions are, according to the occasion, substituted for the one of which proof is required. Sometimes the Particular for the Universal; sometimes a proposition with different Terms: and various are the contrivances employed to effect and to conceal this substitution, and to make the Conclusion which the Sophist has drawn, answer, practically, the same purpose as the one he ought to have established.

Whately added (p. 140) that very often this fallacy works because some emotion is excited in the hearer that brings him into a disposition suited to the speaker's purpose even though the hearer may not have explicitly accepted the speaker's conclusion. Whately offered an excellent example—a case of “peculation” (embezzlement)—to illustrate his point (p. 140):

*Case 2.3:* So also if any one has pointed out the extenuating circumstances in some particular case of offense, so as to show that it differs widely from the generality of the same class, the Sophist, if he find himself unable to disprove these circumstances, may do away the force of them, by simply *referring the action to that very class*, which no one can deny that it belongs to, and the very name of which will excite a feeling of disgust sufficient to counteract the extenuation; e.g. let it be a case of peculation; and that many *mitigating* circumstances have been brought forward which cannot be denied, the sophistical opponent will reply, “Well, but after all, the man is a *rogue*, and there is an end of it;” now in reality this was (by hypothesis) never the question; and the mere assertion of what was never denied, *ought* not, in fairness, to be regarded as decisive; but practically, the odiousness of the word, arising in great measure from the *association of those very circumstances* which belong to *most of the class*, but which we have supposed to be *absent* in *this particular* instance, excites precisely that *feeling of disgust*, which in effect destroys the force of the defence.

This case, as outlined by Whately, is quite useful generally in showing how appeals to emotion are tied in with the fallacy of irrelevant conclusion. In this case, the *ad hominem* argument is used in calling the person a “rogue,” but the

same pattern of argumentation could also be used in connection with other appeals to emotion like the *ad populum*, *ad misericordiam*, or *ad baculum*. The force of the defense is destroyed by dwelling on some proposition that is not really at issue, but that leaves a certain feeling in the minds of the audience (or judge or hearer, as the case may be) that makes the argument for the defense somehow look bad or unappealing. The argument put forward does not prove what it is supposed to prove, but by evoking a certain emotion or attitude it creates a climate or ambiance that tilts the balance of considerations in the case sharply to one side, in the minds of the audience. How such a fallacy works will be investigated in chapter 7.

Whately went on to offer a collection of examples that do present an interesting and plausible account of how the Aristotelian fallacy of misconception of refutation, or irrelevant conclusion, can be used as a sophistical tactic in argumentation.

- Case 2.4:* Instead of proving that “this Prisoner has committed an atrocious fraud,” you prove that “the fraud he is accused of is atrocious” (p. 140).
- Case 2.5:* Instead of proving (as in the well-known tale of Cyrus and the two coats) that “the taller boy had a right to force the other boy to exchange coats with him,” you prove that “the exchange would have been advantageous to both” (p. 140-141).
- Case 2.6:* Instead of proving that “a man has not a right to educate his children or to dispose of his property, in the way *he thinks best*,” you show that the way in which he educates his children, or disposes of his property is not *really the best* (p. 141).
- Case 2.7:* Instead of proving that “the poor ought to be relieved in this way rather than in that,” you prove that “the poor *ought to be relieved*” (p. 141).
- Case 2.8:* Instead of proving that “an irrational-agent—whether a brute or a madman—can never be deterred from any act by apprehension of punishment,” (as for instance, a dog, from sheep-biting, by fear of being beaten) you prove that “the beating of one dog does not operate as an *example* to *other* dogs,” &c. and then you proceed to assume as premises, conclusions different from what have really been established (p. 141).

All these cases are quite plausible examples of arguments used in familiar contexts where there has been an easily overlooked or concealed shift from

proving one proposition to arguing for a second. Arguing for the second proposition does not prove what is supposed to be proved, but it can effectively create a certain ambiance or climate of opinion that somehow makes the opposing side look bad, or appear to have been defeated. The reason is that the conclusion actually proved resembles the conclusion that is supposed to be proved, but is not identical to it.

The first case (2.4) is particularly significant because it shows how the fallacy of irrelevant conclusion could be used effectively in a criminal trial, suggesting the framework in which Hermagoras defined relevance in ancient rhetoric. As we will see in chapter 3, this type of case was taken up by the modern logic textbooks as a key example of *ignoratio elenchi*. Whately's exposition of the Aristotelian *ignoratio elenchi* fallacy, and the examples he used to illustrate it, are very interesting. They not only show how this fallacy can be tied in with other fallacies, like the various appeals to emotion, but they also indicate how *ignoratio elenchi* can function as an independent fallacy in its own right (as in the five cases just cited).

Whately also showed, using two other very good examples, how the *ignoratio elenchi* fallacy is tied in to the fallacy now called the straw man. Whately (p. 141) suggested that *ignoratio elenchi* is frequently used in an apparent refutation of an opponent's proposition by "attributing to a person opinions, etc. which he perhaps holds in abhorrence." Whately illustrated this variant of the *ignoratio elenchi* using the following two cases (p. 141):

*Case 2.9:* Thus, when in a discussion one party vindicates, on the ground of general expediency, a particular instance of resistance to Government in a case of intolerable oppression, the opponent may gravely maintain, that "we ought not to do evil that good may come": a proposition which of course had never been denied; the point in dispute being "whether resistance in this particular case were doing evil or not."

*Case 2.10:* Or again, by way of disproving the assertion of the "*right of private-judgment in religion,*" one may hear a grave argument to prove that "it is impossible every one can be *right in his judgment.*"

These cases show a genuine close connection between the *ignoratio elenchi* fallacy, as it is conceived by Whately, and the straw man fallacy. But unfortunately, this connection probably also tended to reinforce the confusion between straw man and misconception of refutation produced by Arnauld's analysis. The treatment of both these fallacies became problematic in the modern textbooks, where it became extremely difficult to clearly distinguish the one fallacy from the other. Whately's comparatively clear and potentially useful account of

*ignoratio elenchi* was very influential in subsequent textbook treatments of this fallacy. For example, it was quoted extensively in the account of *ignoratio elenchi* given in Mill's *System of Logic* (1843; 1970, pp. 542-543). However, after Whately, the quality of these treatments deteriorated.

## 9. MCCOSH ON SHIFTING GROUND

James McCosh was Professor of Logic and Metaphysics at Queen's College, Belfast, and then President of New Jersey College, which became Princeton University. His logic textbook, *The Laws of Discursive Thought* (1879) was influential in its time. In the part of the book on fallacies, McCosh cited two fallacies that were generally fallacies of irrelevance. One was called *ignoratio elenchi* or irrelevant conclusion, defined in the Aristotelian way (p. 186):

Logicians suppose that in discussion the opponent should prove the elenchus or contradictory of your doctrine; and when he fails to do this, and establishes a different proposition, he is said to be guilty of an Ignoratio Elenchi. But the language may be so widened as to include under it all cases of Irrelevant Conclusion—that is, in which persons establish, not the conclusion which they ought, but another which may be mistaken for it.

The other, called the *fallacy of shifting ground*, is not defined, but two examples are cited.

*Case 2.11:* *Fallacy of Shifting Ground*, as when the advocate or opponent of a cause begins as if he were about to prove it to be good and right, and as he proceeds shows that some good may be derived from it; or that it is wrong and bad, and shows that it has led to certain supposed evil results (p. 183).

*Case 2.12:* Under this head may be placed the common practice of persons professing to prove that a certain deed has been done, but dwelling chiefly on the enormity or the excellence of the deed, with the view of rousing the feelings and to prevent it being seen that they have not established their point. Francis Bacon is charged with having received an estate from his friend the Earl of Essex, and afterwards being unkind to him; and the strength of the writer is expended in dwelling on the evil of ingratitude, especially on the part of so great a man, instead of proving the alleged facts (pp. 183-184).

The second case of this pair sounds similar to Whately's case (2.3) where the issue is whether a man has committed embezzlement, and the opponent replies, "Well, but after all, the man is a *rogue*, and there is an end of it." In this variant, Bacon is accused of "the evil of ingratitude," which also seems to involve an attack on character.

The difference is that in case 2.12, a significant part of the fallacy is that the writer dwells in the abstraction on "the evil of ingratitude" as a general issue, thereby masking his failure to prove "the alleged facts," that is, to prove that in fact Bacon did receive the estate in question from his friend, and was afterward unkind to him. In this respect, case 2.12 is similar to the case cited by Whately (case 2.4), where the arguer proves that the fraud the prisoner is accused of is atrocious, instead of proving that the prisoner has committed an atrocious fraud.

It should also be noted that the first of McCosh's illustrations of the fallacy of shifting ground (case 2.11) is problematic as it stands. If an advocate of a cause is to prove that cause to be "good and right," if he proceeds to show "that some good may be derived from it"—that is, that it has some good consequences—then such an argument would be, or at least could be, relevant to what the advocate is supposed to show. The general point to be made here is that argumentation from consequences is a commonly used, reasonable type of argument. As shown in Walton (*Arg. Schemes*, 1996, chap. 6), arguing that a policy is good or right on the ground that the policy has good consequences is a defeasible, but presumptively reasonable form of argument.

Hence, the example offered by McCosh in this instance is potentially confusing because (1) it cites as an instance of the fallacy of shifting ground a type of argument that is not inherently fallacious, and (2) tends to foster a confusion in the readers of the text between the fault of irrelevance generally and the specific type of argument identified with argument from consequences, which can be fallacious, but not always on grounds of irrelevance. So the kind of example cited by McCosh in case 2.11 is not altogether a bad one, but due to its brevity of treatment in a textbook format, it has an unfortunate tendency to lead to a number of confusions.

Over and above these specific points of contention however, there is a general problem inherent in the way McCosh treated fallacies of irrelevance. McCosh's treatment of the fallacy of irrelevant conclusion is essentially Aristotelian, and is very similar, in general outline, to Whately's account of this fallacy (also called *irrelevant conclusion* and *ignoratio elenchi* by Whately). McCosh even used one example (p. 186) that is very similar to Whately's case 2.6:

*Case 2.13:* The dispute is, whether any one has a right to compel a father to educate his child in a way different from what he is doing, in religion or in something else, and one of the disputants thinks he

has settled the whole question when he has shown that the father is educating his child wrong.

The supposed fault in this case is not expressed as succinctly as the *ignoratio elenchi* was illustrated by Whately in his case 4.6. Nevertheless, from his use of such a comparable example, it is clear that McCosh is thinking of *ignoratio elenchi* as a very similar kind of fallacy to the one described by Whately. Both accounts seem to be essentially describing the Aristotelian fallacy of misconception of refutation, and both accounts explicitly purport to do so.

The problem is, then, where McCosh came up with this separate fallacy of shifting ground and how it is different from the fallacy of irrelevant conclusion. At present, there is no good answer to this question. For the present, all we can do is to note this “twinning” or “splitting off” tendency to divide general irrelevance as a fault into two separate fallacies. It is a tradition we will see (in chapter 3) preserved, carried on, and even extended in the modern textbooks. Whether it is a tradition worth preserving will be determined in chapter 5.

## 10. THE PERSPECTIVE OF SCHILLER AND SIDGWICK

Ferdinand Canning Scott Schiller (1864-1937) was a pragmatist philosopher who taught at Oxford University. Schiller criticized formal logic as a verbal game that “etherealized” and “depersonalized” truth, abstracting too much from the reality of actual thinking processes. In his book, *Logic for Use* (1929), Schiller argued that the concept of relevance, although it is needed by the practical man, is not purely a matter of verbal form, and consequently formal logic of the kind that has been dominant for two millennia has “failed to recognize the existence and importance of relevance” (p. 75). According to Schiller, “it was left to the lawyers, . . . who had a pressing professional need for the notion [of relevance] . . . to evolve the conception and its vocabulary” (p. 75). Schiller’s historical observations on this point are quite accurate and revealing. As we have seen, it is from the theory of Hermagoras, using primarily a legal framework to analyze the structure of relevance, that the concept of relevance in argumentation was first articulated in a useful way.

But the discipline of logic did not utilize or follow up on this concept, and the ancient Greek idea of a dialectical framework of argument fell into disuse, never really catching on as an important structure for evaluating arguments in logic. Instead, Aristotle’s syllogistic, or formal (semantic) logic, rose to be the dominant and even exclusive model of logical reasoning, and the pragmatic and dialectical framework of the *Topics* and *On Sophistical Refutations* was neglected, becoming an obscure and empty tradition.

Schiller, in *Formal Logic* (1912) showed how these historical developments affected the Aristotelian fallacy of *ignoratio elenchi* (p. 357):

The Fallacy of *Ignoratio Elenchi*, or *Irrelevant Conclusion*, originally meant something quite definite, viz. arguing to the wrong point, and proving something else than the ‘confutation’ (i.e. the contradictory) of an opponent’s thesis in a discussion. From missing the point to be proved it has been extended to mean irrelevant argument in general, without definite reference to an opposed thesis. But the detection of Irrelevance is utterly beyond the power of Formal Logic. For the relevance of any part of an argument depends on the purpose of the whole and a knowledge thereof, and Formal Logic thought it clever to simplify its task by ruling out the relation of reasoning to purpose.

As Schiller pointed out, and as was made clear in the analysis of *stasis* of Hermagoras, relevance in a sequence of argumentation depends on the purpose of the discussion in which the argument is embedded and, in particular, on the issue that the discussion is supposed to resolve or bear on. But, as Schiller added, once logic fixed on the structure of deductive inference as its central concern and methodology, and was very successful in pursuing this course, the pragmatic and dialectical task of relating reasoning to a purpose—to a context of use in a dialectical exchange between two parties—was cast aside as being outside the scope of logic. As Schiller nicely put it, the logicians “thought it clever to simplify” the task by simply “ruling out” this dialectical aspect of argument.

Schiller added (p. 358) that all fallacies are moves in argument that are “not to the purpose” of a discourse. So there is a difficulty in treating *ignoratio elenchi* as a single fallacy. Once this difficulty is realized, Schiller adds (p. 358), there is another difficulty in treating *ignoratio elenchi* as an error to be dealt with by logic. For it may also be realized that whether something is relevant or not cannot be decided by formal logic alone. Schiller noted (p. 358), following Aristotle’s own comment to the same effect, that a syllogism can be perfectly valid and (from a formal logic viewpoint) “prove its conclusion flawlessly,” even while it commits the *ignoratio elenchi* fallacy, because it has the “wrong” conclusion, that is, “wrong” with respect to what should properly be proved in relation to the issue to be discussed or resolved in the dialogue exchange.

Schiller’s critique of formal logic was inspired by the ideas of Alfred Sidgwick (1850-1943), a precursor of the informal logic movement who investigated natural language argumentation with a view to devising a practical logic (Nielsen, 1997, p. 400). Sidgwick was the author of six books in this field, as well as several articles, mainly published in the journal *Mind*—a bibliography may be found in Nielsen (1997, 413-428). Sidgwick’s comments on the

evolution of the *ignoratio elenchi* fallacy (1914, p. 149) are particularly interesting:

*Ignoratio Elenchi.* This comes in the list “extra dictionem.” Originally it meant proving something other than the contradictory of an opponent’s assertion, but it has now come to be identified with irrelevant argument in general. Both the fallacy itself, and the accusation of it, are as common as possible; and the more we understand that all thought is purposive the more we shall be able to discover the less obvious kinds of irrelevance in argument.

Sidgwick’s insightful remark on the historical development of the *ignoratio elenchi* fallacy is a perfect bridge between the description of Aristotle’s treatment of that fallacy, as outlined in chapter 2, section 1, and the new dialectical theory of fallacies of irrelevance presented in chapter 6. The logic textbooks came to identify the *ignoratio elenchi* fallacy with what is called “irrelevance” in English (as will be shown in chapter 3). In Aristotle’s original view of the *ignoratio elenchi* fallacy, it meant something somewhat different and apparently narrower—“proving something other than the contradictory of an opponent’s assertion,” in Sidgwick’s words.

What is most interesting is Sidgwick’s remark that the way to discover the “less obvious kinds of irrelevance in argument” is to go with the hypothesis that thinking is purposive. This assumption goes against the traditional approach of formal logic as a tool to study arguments. Both Sidgwick and Schiller were very much out of the mainstream, and ahead of their time, from a dialectical viewpoint.

Schiller took the point of view of a pragmatist philosopher with a humanistic orientation. He was familiar with the methods of formal logic, then about to display a sharp ascendancy, but stood somewhat outside the perspective of the purely formalistic approach to the evaluation of arguments. His pragmatic views were unpopular at the time and have attracted very little attention since then, in the mainstream of modern logic. But we can now see, looking over the development (or lack thereof) of the concept of relevance since the time of Aristotle, that his perspective turned out to be quite accurate and revealing. Unfortunately, until 1970 and subsequently, there was no light at the end of the tunnel. As formal deductive logic became the only kind of logic to be taken seriously in the first seventy years of the twentieth century (up to the publication of *Fallacies* and beyond), the treatment of relevance in the logic textbooks became even more murky and fragmented.



*This page intentionally left blank*

## Textbook Treatments of Irrelevance

Chapter 3 gives a survey of how the twentieth-century logic textbooks have dealt with relevance by postulating many different fallacies of irrelevance. In this chapter, a survey is made of the treatments of the fallacy of irrelevance in the modern logic textbooks, from 1878 to 1995. The leading treatments are selected, summarized, and commented on. A main focus of interest is on the examples they used to illustrate fallacies of irrelevance. The idea is to get a practical grasp of relevance by studying textbook examples, useful in formulating and testing out the theory of relevance and irrelevance to be developed in subsequent chapters. Some of the examples of irrelevance cited as cases of fallacies in the logic textbooks are political or legal arguments. As shown in chapter 1, political rhetoric is a common kind of example. Another is the trial in which an attorney tries to use some argument that is “irrelevant” to sway a jury (often by an emotional appeal). These textbook accounts are surely right that relevance is a vitally important concept in the law of evidence and in the conduct of legal trials.

The fallacy of *ignoratio elenchi*, variously treated under headings like “misconception of refutation,” “ignoring the issue,” “irrelevant conclusion,” “missing the point,” “red herring,” and so forth, has been treated as a separate fallacy (or in some cases, as two separate fallacies) in modern logic textbooks. This chapter is a survey of the most popular, substantial, and influential treatments.<sup>1</sup> It does not cover all treatments of what is taken to be the central fallacy or fallacies of irrelevance in the logic textbooks. But it is an indicative sampling of the traditional way of handling these fallacies.

Traditionally, in logic, many kinds of arguments and kinds of moves made in argumentation have been criticized as “irrelevant.” The problem is that the term *irrelevant* has never been defined in any precise or clear enough way to be useful in logic for the critical analysis and evaluation of arguments. As Hamblin (1970, p. 31) commented, the Aristotelian account of the fallacy of irrelevant conclusion “can be stretched to cover virtually every kind of fallacy,” or “it can be restricted to clear cases of misinterpretation” of an arguer’s thesis to be proved in a discussion. Other accounts between and outside these extremes are also possible. In fact, the textbook accounts are all over the map on how to

---

<sup>1</sup> Not all of the textbooks having a section on this type of fallacy, or giving some account of it, were chosen to appear in this survey. It nevertheless considers a fairly substantial number of textbook accounts from 1878 to 1995. Most leading accounts are represented.

interpret this fallacy. Some, as Hamblin notes (p. 31), treat it “frankly as a rag-bag.” Many accounts that are more specific disagree with the other textbooks. Our survey reveals a conceptual disarray due to a lack of agreement on how to define relevance. By observing the alleged failures of relevance in the examples cited by these textbooks, some important clues are given in indicating what sorts of problem cases a theory of relevance should address.

## 1. MINIMALISTIC ARISTOTELIAN ACCOUNTS

In this first selection of early modern logic textbooks, ranging from 1878 to 1929, the *ignoratio elenchi* fallacy is treated very briefly and sketchily. In each account, a basically Aristotelian definition of the fallacy is given, and the fallacy is assigned an English label like “irrelevant conclusion” or some comparable variant, like “surreptitious conclusion.” Either no examples at all are given, or only the sketchiest outline of a possible case is presented. The gist of the fallacy described in these textbooks is the shift from proving a particular conclusion that is supposed to be the thesis to be proved (or refuted) to proving some other proposition that may be close to it, or related to it, but is not identical to it. The problem with all these accounts of the fallacy is that only the briefest of examples are offered, and they are sketched in a minimalistic way. This minimalist treatment must have left plenty of room for puzzlement on the part of the student readers of the textbook, leaving the way open for subsequent textbook writers to try to fill the gap.

Jevons (1878, p. 178) defined the fallacy of *ignoratio elenchi* or “irrelevant conclusion” as “arguing to the wrong point, or proving one thing in such a manner that it is supposed to be something else that is proved.” He added that it would be difficult to give a “concise” example of this fallacy because it usually occurs in “long harangues” where there is room for “confusion” and “forgetfulness” (p. 178). However, Jevons did give an example of the *argumentum ad hominem* (p. 179), which he classified as also being a species of irrelevant conclusion fallacy:

**Case 3.1:** If a great change in the law is proposed in Parliament, it is an Irrelevant Conclusion to argue that the proposer is not the right man to bring it forward.

The problem with this account is that sometimes *ad hominem* arguments are quite reasonable, that is, nonfallacious.

It could be, for example, that this person has often contravened the principle advocated by this change in the law so that his argument for it is not very credible. On the other hand, the credibility of the proposer is, or could be, in a certain sense, not really relevant to the issue of whether the proposed

change in the law is good legislation for the country or not. The central problem is to figure out what sense of *relevant* is meant here. It appears hard to say, and Jevons makes no attempt to solve the problem.

Fowler (1895, p. 149) called *ignoratio elenchi* “the fallacy of irrelevancy,” and gave an Aristotelian account of it. However, he added that this term now has a wider meaning than that given to it by the ancients and offered a general sketch of the sorts of argument typical of this new meaning.

The fallacy of Irrelevancy (or, as it is sometimes called, shifting ground) is technically termed *Ignoratio Elenchi*, i.e. ignorance of the syllogism required for the refutation of an adversary. Thus, in the strictest sense of the words, *ignoratio elenchi* is committed by a person who in a disputation does not confine himself to proving the contradictory or contrary of his adversary’s assertion, or who proves a proposition other than the contradictory or contrary. But, like many other terms borrowed from the dialectical disputations of the ancients, this has now received a wider meaning. Whenever an argument is irrelevant to the object which a speaker or writer professes to have in view, it is called an *ignoratio elenchi*. Thus, if I am endeavoring to convince a person that some particular measure is for his personal interest, and I adduce arguments to prove that it contributes to the general utility, or that it is the necessary consequence of other acts of legislation, I am guilty of an *ignoratio elenchi*, as I should also be if, when it was my object to establish either of the other two conclusions, I were to appeal to his personal interest. When the question at issue is the truth of an opinion, it is an *ignoratio elenchi* to attack it for its novelty, or for its coming from a foreign source, or for any supposed consequences which may result from it, or to try to throw discredit on its author by saying that it has often been stated before, and so is no discovery of his.

We can get an idea of what Fowler is driving at from the two types of cases he briefly sketches out or alludes to, but like Jevons’ account, the problem is that these kinds of arguments may be used nonfallaciously in some instances. For example, adducing an argument to prove that some measure “contributes to the general utility” could be a relevant part of a longer sequence of argumentation used to prove that the measure is in the personal interest of the hearer. And if the question at issue is the truth of an opinion about some legislative policy, the “supposed consequences” that may result from carrying out the policy may be quite relevant to the issue. The problem is that Fowler’s account of the *ignoratio elenchi*, like Jevons’, is superficial, because it is based only on the sketchiest outline of some possible cases. Such a superficial treatment leaves open the possibility that the argument cited may not really be fallacious at all (depending on further particulars of the case).

Jevons, as noted, even admitted this liability of his account apologetically, conceding that it would be “difficult” to illustrate the fallacy with “concise examples.” The presumption seems to be that the fallacy must be dealt with in a short space, suggesting that the presentation of any lengthy or complex case would be inappropriate.

Another textbook (Latta and MacBeath, 1929; 1956) gives an account of the *ignoratio elenchi* that is perfectly typical of these early minimalist Aristotelian treatments of the fallacy (p. 379):

*Ignoratio Elenchi* or *Irrelevant Conclusion*. This fallacy consists in proving the wrong point. The reasoning involved may be perfectly valid, but the conclusion arrived at is not exactly what was wanted in the circumstances. Aristotle applied the term to cases in which a disputant proved some point other than the logical contradictory of the thesis maintained by his opponent, *i.e.* something other than what was required to refute his opponent; but modern usage applies it to all cases of proving something other than what is wanted. When a judge or jury is affected by the character of a prisoner rather than by the evidence of his having committed the crime of which he is accused, we have an instance of this fallacy.

This account is perfectly typical in its sketchiness, its Aristotelian inspiration, its use of a brief *ad hominem* argument as an illustrative case, and its indication that the Aristotelian sense of the fallacy has been widened in modern usage. Also typical is Latta and MacBeath’s follow-up citing several other traditional *ad fallacies* as coming under the general heading of *ignoratio elenchi*.

As shown in the next section, many subsequent textbooks began to grope around to express the Aristotelian concept of *ignoratio elenchi* in modern terms. Many tried to give examples that might indicate, in a modern context, what this fallacy amounted to. However, the examples given were still quite brief, leaving a lot of room for interpretation.

## 2. PROBLEMATIC CASES

In the next group of textbook accounts, covering the period from 1904 to 1920, the authors tried to confront the problem that their modern readers would have no grasp or appreciation of the Aristotelian idea of argument as a dialectical exchange where one party is supposed to refute the thesis of the other. To fill this gap, they introduced the idea of *ignoratio elenchi* as a fallacy on the ground that the argument presented was too weak, failing to supply sufficient evidence, or the right sort of evidence, to support a conclusion. As noted in chapter 1, section 1, confusing weakness and irrelevance in arguments is an error. But

lacking a clear analysis of irrelevance as a fallacy, the early textbooks were not in a good position to combat this error.

Creighton (1904, pp. 166-167) defines the fallacy of irrelevant conclusion as the substitution of one proposition for another in an argument:

The Irrelevant Conclusion, or *Ignoratio Elenchi*, consists in substituting for the conclusion to be proved some other proposition more or less nearly related to it. This fallacy may be the result of an involuntary confusion on the part of the person employing it, or it may be consciously adopted as a controversial stratagem to deceive an opponent or an audience. When used in this latter way, it is usually intended to conceal the weakness of a position by diverting attention from the real point at issue. This is, indeed, a favorite device of those who have to support a weak case.

Creighton (p. 167) cites the *ad hominem* argument of the *tu quoque* subtype as an example of the fallacy of irrelevant conclusion. The *tu quoque* argument, according to Creighton (p. 167) is “to answer a charge or accusation by declaring that the person bringing the charge is guilty of as bad, or even worse things.” Thus Creighton’s account of the *ignoratio elenchi* is similar to that of Jevons and Fowler and suffers from the same difficulty. For the *tu quoque* reply can sometimes be a reasonable type of argument, for example, in a legal cross-examination of an accuser who is known to have made false accusations on previous occasions.

The problem is illustrated by Creighton’s citing a brief example (p. 167):

*Case 3.2:* In controversial writing, it is very natural to assume that a proposition which has some points of connection with the conclusion to be established, is ‘essentially the same thing,’ or ‘practically the same, as the thesis maintained.’ Thus one might take the fact that a great many people are not regular church-goers, as a proof of the proposition that religion and morality are dying out in the country. Many of the arguments brought against scientific and philosophical theories belong to this class.

The problem here is that if you are obliged to prove the proposition “religion and morality are dying out in this country,” a relevant part of your argument could be the citation of figures to show that church attendance is declining. Of course, as Creighton maintained, proving that church attendance is declining in this country is not the same as proving that religion and morality are dying out in this country, and to take it as so would be fallacious reasoning. The fallacy in such a case would be one of stopping too soon, before going on to present the rest of the argument that is needed to prove your conclusion. Still, the

proposition that church attendance is declining is relevant to proving your conclusion. So it is unclear how an argument using this premise can generally be dismissed as fallacious. A fuller description of the case appears to be needed if the reader is to be instructed on how to distinguish between the fallacious and nonfallacious instances of the kind of argumentation cited in the case.

Hibben (1906, pp. 162-163) also gave an Aristotelian account of the fallacy:

*Ignoratio Elenchi*—This is a fallacy which consists primarily in an ignorance of the nature of refutation. To refute an argument, its logical contradiction must be established. Any proof which falls short of this fails in its end. The nature of this fallacy has been enlarged in scope, so as to comprise any argument whatever which does not squarely meet the point at issue. It is, in many cases, not so much the ignorance of the point at issue, as purposely ignoring the point at issue. It is a natural method of argument when one has a weak case. Any subterfuge which withdraws attention from the point at issue tends, of course, to strengthen the weaker side, at least as regards the plausibility of its position.

Hibben, like Fowler, noted that the scope of this fallacy has come to be widened since the Aristotelian account. Only one very brief example was given (Hibben, 1906, p. 163):

*Case 3.3:* Suppose a student should be urged to spend more time upon his Latin or Greek, and he should excuse his negligence by insisting that in after life he would never find any practical use for his classics—this would be the fallacy of *ignoratio elenchi*.

We can see the point of this case as intended. Once the student is enrolled in the course and can no longer withdraw, then his problem is to pass the exam, and the issue of whether classics is useful after graduation is not relevant to this problem. On the other hand, the case is very sketchy. The question of the usefulness of classics in “after life” is relevant to the student’s deliberations if it is still possible for him to drop the course and perhaps take something he thinks to be more practical. This sort of case would be confusing to students reading Hibben’s textbook because it does seem that the question of the usefulness of classics is, or may be, somehow relevant to the case.

Read (1898; 1920, p. 398) called *ignoratio elenchi* “the fallacy of surreptitious conclusion,” and defined it as “the mistaking or obscuring of the proposition really at issue, whilst proving something else instead.” The example given illustrates the substituting of a universal for a particular proposition or vice versa (p. 398):

*Case 3.4:* He who attacks the practice of giving in charity must not be content to show that it has, in this or that case, degraded the recipient; who may have been exceptionally weak. Or, again, to dissuade another from giving alms in a particular case, it is not enough to show that the general tendency of almsgiving is injurious; for, by taking pains in a particular case, the general tendency may often be counteracted.

Here again, the case is problematic. Showing that giving to charity has turned out badly in one case is not sufficient to prove that giving to charity is always a bad practice, but it surely could be relevant to such a proof. So the exact nature and import of the *ignoratio elenchi* fallacy is not demonstrated very clearly by this case. Nor is the student shown generally how to distinguish between fallacious and nonfallacious cases, or to determine clearly when a proposition is relevant in an argument and when not. To add to the confusion, Read (1920, p. 398) presented another very brief example where, in contrast to the prior case, the premises cited do not appear to be relevant.

*Case 3.5:* Sometimes an argument establishing a wholly irrelevant conclusion is substituted for an *argumentum ad rem*. Macaulay complains of those apologists for Charles I who try to defend him as a king, by urging that he was a good judge of paintings and indulgent to his wife.

In this case, if the issue is whether Charles was, let's say, a competent king, whether he was a good judge of paintings or indulgent to his wife do not seem to be relevant at all to this issue. But they could be, if the context of the case were expanded.

In case 3.5, the premises cited seem to be irrelevant because they are too weak as evidence to support the conclusion that is supposed to be proved or because they are not even the right sort of evidence at all to prove that conclusion. What sort of irrelevance is this? Read has defined irrelevance—or the fallacy of surreptitious conclusion—as the mistake of “obscuring the proposition really at issue” while “proving something else instead.” This Aristotelian fallacy is well enough illustrated by case 3.5. And so that case, although only very sketchily presented, does move us some way toward seeing how the Aristotelian idea of *ignoratio elenchi* could be a significant fallacy as applied to arguments that would be of interest to the modern student. However, even this more plausible and promising kind of example leaves the student in the dark on how, in general, we are supposed to determine whether a proposition cited as evidence to support a conclusion is relevant for that purpose or not. Logic, of the modern kind, does not appear to have any resources that



can be applied to tell us what the issue is supposed to be in a given case or what is or is not relevant to that issue (once determined) in that case.

### 3. THE DUAL APPROACH

Cases 3.4 and 3.5 seem to involve two different kinds of failures of relevance. The next development was the explicit division of irrelevance into two fallacies, treated under separate headings, but both having as their primary fault the failure to be relevant. The problem is that different texts made the division in different ways, producing a fragmentation of fallacies of relevance.

Castell (1935) distinguished between two fallacies of irrelevance which, he wrote (p. 22), are “easily confused.” One commits the *fallacy of irrelevant thesis* where, for distinct propositions  $X$  and  $Y$ , “one argues for or against  $X$  when one should argue for or against  $Y$ ” (p. 22). Castell (p. 21) gave the following example to illustrate the fallacy of irrelevant thesis:

**Case 3.6:** There is a principle, in ethics and politics, known as *laissez faire*. It is to this effect: *If you let things alone, a minimum of trouble will result.* If, that is to say, government restrains its activities to a minimum, keeps out of business, passes few instead of many laws, then less trouble and confusion will result. This principle may be false, but its meaning is clear. Now, suppose a critic of this principle were to argue: *Laissez faire is an unsound principle of social philosophy. Need anyone be reminded that we are sadly mistaken if we think we shall, by letting things look after themselves, attain to any social utopia?* He would be advancing an irrelevant thesis. His argument would be an instance of what is called the fallacy of Irrelevant Thesis; that is, arguing for or against an irrelevant point. Against the claim that by letting things alone we will produce a minimum of trouble, it is irrelevant to argue that by letting things alone we will not produce a social utopia. Because that claim was not made in the name of *laissez faire*; and to upset it is to leave the principle of *laissez faire* untouched.

The fallacy of irrelevant thesis seems to be very similar to, or the same as the Aristotelian fallacy of *ignoratio elenchi*, although Castell did not use the Latin expression. Just in passing we might observe that case 3.6 suggests the straw man fallacy as well.

The *fallacy of irrelevant evidence* is committed where “facts are presented as evidence or grounds for  $X$ , which are actually irrelevant to  $X$ ” (p. 22). Castell offered the following example (p. 22) to illustrate this fallacy:

Case 3.7: Suppose a fundamentalist were to urge the following line of thought in support of the proposition that the theory of evolution is a false theory: *Examine its credentials. Was it accepted by the great biologist Agassiz? Or the great statesman Gladstone? Examine its implications. Is it compatible with revealed religion? Is it conducive to sound morality? Examine its evidence. Has any man ever seen anything evolve? Can any scientific theory, no matter how plausible, ever be proven true? To all these questions, and to dozens more, the answer is No.* This argument illustrates very beautifully the meaning of the term *irrelevant evidence*. Suppose the answer *No* is given to each question. What of it? Suppose Agassiz did not accept it. What of it? Suppose it is not compatible with revealed religion. What of it? Suppose no man ever did see anything evolve. What of it? The point is, that all of these suppositions could be true or false, and still make no difference to the truth or falsity of the theory of evolution. That theory may be false. But its falsity would not follow from the facts cited. That is, these facts are irrelevant. Whenever the facts cited are thus wide of the point, the argument is fallacious.

The fallacy in this case turns on the question of what sort of evidence gives grounds for acceptance or rejection of a proposition. As Castell himself noted (p. 23), the phrase “irrelevant evidence” is something of a contradiction: “If facts are irrelevant, then of course they are not evidence; and if they are evidence, they are not irrelevant.” In a way then, the use of the term *relevance* here is distracting. The key to this fallacy lies in the concept of evidence.

The idea of “irrelevant evidence” as a fallacy was also taken up by Werkmeister (1948), who defined it as follows (p. 56).

*Irrelevant Evidence*—In order to prove a point or to establish a conclusion, the evidence advanced in its support must always be relevant; that is, it must be directly related to the point at issue. All unrelated or extraneous matter is irrelevant. If such irrelevant matter is presented or accepted as “evidence,” the result is a fallacy of *irrelevant evidence*.

Werkmeister then went on to analyze the *ad hominem*, *ad populum*, and other traditional fallacies, as subspecies of the fallacy of irrelevant evidence.

Fearnside and Holther (1959) also distinguished between two types of failures of relevance as fallacies, but in a different way from Castell. Both of their fallacies would seem to be subspecies of Castell’s fallacy of irrelevant thesis. They distinguished between the fallacy of diversion and the red herring fallacy. The *fallacy of diversion* is described as follows (p. 121):

To make a diversion is to lead discussion away from the issues by directing it elsewhere. There are many devices for doing this: resorting to humor, bringing up irrelevant material, interrupting thought with trivial protests or questions, appealing to pathetic circumstances. There is no complete defense against diversions. Their function is to make the audience forget the point or become unwilling to consider it. After a successful diversion the audience may find it tedious to get back to business. To be sure, audiences generally do have a sense of fair play which demands that individuals be given a hearing, and people may resent a diversion if they recognize it as such; so sometimes it is effective to expose a diversion and then appeal for orderly discussion. Diversions, like almost all other fallacies, occur also in writings and speeches where no party is responsible to answer and where the alertness of the audience or reader is the only guard.

The type of tactic used in this fallacy is to lead discussion away from the issue. The other fallacy of irrelevance cited by Fearnside and Holther (p. 124) is called "clamorous insistence on irrelevancies" or "red herring":

One way of hiding the weakness of a position is to draw noisy and insistent attention to a side-issue. The side-issue may be the character of an opponent, who is damned vigorously while the argument gets lost in personalities. Or it may be some movement or group that serves as a whipping post. This, the red-herring technique, is the tactic of the familiar speaker who, instead of meeting the real question, turns his talk into an attack on international communism, or Wall Street, or whatever else will deflect the attention of the audience. Such speakers often lose all sense of proportion, they pettifog, they make much of little and little of much. They talk of anything except the issue, at great length, with much noise and sawing of the air. We all are addicted to this fallacy. It is, of necessity, the patron saint of those being overwhelmed in argument.

The problem is that this fallacy sounds a lot like the fallacy of diversion, and it is hard to tell what the difference is supposed to be between the two. The fault of red herring is to turn the talk onto other matters "instead of meeting the real question," but this fault also seems to be characteristic of the fallacy of diversion.

Perhaps the difference is that in the fallacy of diversion, another line of argumentation is developed that moves away from the point at issue, whereas in clamorous insistence on irrelevance there is only "much noise and sawing of air" in place of any argument at all. It is unclear from Fearnside and Holther's account whether this factor is meant to be the key difference between the two

fallacies or not. How Fearnside and Holther's pair of fallacies is related to Castell's pair is unclear. Both of Fearnside and Holther's fallacies seem more likely to be a subspecies of what Castell calls "irrelevant thesis," but it is hard to tell for sure.

At the same time that some textbooks went with the new two-fallacy approach, others stuck with one. Clark and Welsh (1962) gave a concise and clear statement of what is essentially the Aristotelian analysis of the *ignoratio elenchi* fallacy (p. 140):

The English name for the fallacy is "irrelevant conclusion" although the Latin is properly translated as "ignorance of argument" or "ignorance of disputation." If we want to *refute* an argument we must prove the contradictory of the conclusion; if we prove or establish something else, we are ignorant of the principle of disputation. The fallacy, then, consists in a speaker's establishing or proving some other conclusion than the one he claims to be or ought to be proving.

Clark and Welsh grouped several of the traditional *ad* fallacies, including *ad hominem*, *ad populum*, and *ad misericordiam*, under this general heading. However, they give the following example (p. 140) to illustrate the *ignoratio elenchi* fallacy:

**Case 3.8** You do not refute an argument for improved housing by showing that those with low incomes are happy where they are.

Is the argument in this case an instance of the fallacy of irrelevant thesis or irrelevant evidence (by Castell's distinction)? It seems hard to say. It could be either, or both, perhaps. Or it could be a diversion, suggesting a fallacy more along the line of Fearnside and Holther's treatment.

The treatment of the fallacy of irrelevant conclusion in Copi's widely used logic textbook *Introduction to Logic* should be mentioned again at this point. This treatment was outlined in chapter 1.

#### 4. DAMER: FURTHER SUBTLETIES OF RELEVANCE

Damer (1980) presented a different way of classifying fallacies of relevance. Under the general heading Fallacies of Irrelevance, he has a subfallacy called *missing the point*, which has two variants called *irrelevant evidence* and *irrelevant conclusion*.

**Definition:** This fallacy consists in drawing a conclusion that "misses the point" of the evidence, although it purports to follow from the evidence;

or in presenting evidence that does not support a stated conclusion, although it may support some vaguely similar unstated conclusion.

When this fallacy occurs, the question arises as to whether it should be considered a case of irrelevant evidence or a case of an irrelevant conclusion. If the evidence is not in support of the stated conclusion, we could say that the evidence is irrelevant to that conclusion; but we could also say that the conclusion is irrelevant to the evidence. Whatever we may choose to call it, if there is no relevant relationship between the evidence and the stated conclusion, there is no basis for inferring that conclusion, although there may be a basis for inferring some other, perhaps similar or related, conclusion. (75)

Damer seemed to think that whether you call this type of fallacy *irrelevant evidence* or *irrelevant conclusion* is somewhat arbitrary and that the fault in both kinds of cases is that there is no basis [given by the premises] for inferring the conclusion." What seems to be common to Damer's example of the fallacy of missing the point is that the premises, as stated in the given case, are incomplete, and therefore as they stand, give no basis, or an insufficient basis, for inferring the acceptability of the conclusion. In the following case, for example (Damer, 1980, p. 76), there is an implicit connection between the premises and the conclusion, but it is not explicitly presented.

**Case 3.9:** Americans have a great heritage built on fine ideals. And we should all help to carry on this great heritage by passing it on to our children. That is why all Americans should regularly go to church on Sunday.

As things stand, there is no explicit connection given between the premises and the conclusion of this argument. But of course there is a connection, supplied by the implicit premise, 'Going to church on Sunday is part of the American heritage.' Once this premise is added, the premises do provide some evidence to support the conclusion. A similar comment could be made about another example of missing the point cited by Damer (p. 76):

**Case 3.10:** The courts have been grossly unfair to newspaper reporters—forcing some of them to go to prison just because they wouldn't reveal the sources of their information. The reporters keep the public informed, and we all know that a well-informed public is necessary to bring about any semblance of justice. Besides, reporters keep public officials and others 'honest' by digging out the facts behind their claims, and exposing them when they don't tell the truth or when they engage in questionable practices.

Damer commented (p. 76) on this case:

The weight of evidence in this argument supports the view that newspaper reporters perform a very useful and important service for their readers; it does not support the claim that the courts have been unfair to reporters. That particular conclusion misses the point of the evidence.

However, once again, there is a link between these premises and the conclusion via the assumption that the courts have been preventing newspaper reporters from carrying out a useful and important service. Damer was quite right to observe that such a premise is not explicitly stated, nor is any evidence for it given, and that therefore the argument is deficient and weak in this respect.

But is that enough of a basis to call case 3.9 an instance of the fallacy of missing the point, or to say that in case 3.10, the premises provide no evidence for the conclusion, and that therefore the conclusion is irrelevant? This evaluation is somewhat misleading because the premises in both these cases are somewhat relevant in at least one sense. They do provide information that could be used, along with other unstated information, that might not be too hard to find, or at least look for, and that would, taken as a package, support the conclusion. The cases cited by Damer, then, involve a subtlety. The premises are relevant, or somewhat relevant, in the sense that they could be used in an argument when supplemented by other implicit premises, to support the conclusion. But what is tricky or deceptive, and what an audience might overlook, is that they do not (by themselves) provide sufficient evidence to prove or adequately support the conclusion.

Damer also has a category of “irrelevant appeals” (p. 87), under which he included appeals to emotions like appeal to pity, and so forth. And he has a third category, *fallacies of diversion*, including the straw man fallacy (Damer, p. 99, called it “distortion”) and the *red herring fallacy*, “attempting to hide the weakness of a position by drawing attention away from the real issue to a side issue.”

Case 3.11 **Senator Clarke:** Why are you not willing to support the antiabortion amendment? Don’t you have any feelings at all for the unborn children whose lives are being indiscriminately blotted out?

**Senator Davenport:** I just don’t understand why you people who get so worked up about the lives being blotted out by abortion don’t have the same feelings about the thousands of lives that are blotted out every year by an indiscriminate use of handguns. Is not the issue of the sanctity of human life involved in both issues? Why have you not supported us in our efforts at gun-control legislation?

In this case, we can see that the two topics of the antiabortion amendment and the gun-control legislation are somewhat related, as the arguer points out, because sanctity of human life is involved in both issues. Is this connection strong enough, however, to deflect the criticism that Senator Davenport commits the red herring fallacy? No, because the discussion of the one issue is not really appropriate or useful in a debate that is supposed to be on the other issue.

So on both basic types of fallacy of relevance cited by Damer—missing the point and red herring—a subtlety is involved. In both kinds of cases, the premise or issue used or introduced is somewhat relevant to the conclusion to be proved. But in another sense, it fails to be relevant, and it is this latter sense of the term *relevant* that justifies our evaluation of the case as involving a fallacy of relevance.

## 5. JOHNSON AND BLAIR: IRRELEVANT REASON AND RED HERRING

Johnson and Blair (1983) distinguished between two basic fallacies of relevance, called irrelevant reason and red herring. The *fallacy of irrelevant reason* (p. 38) is said to be committed by an arguer where (1) the arguer has put forward a set of propositions,  $Q, R, S, \dots$ , as premises for a conclusion  $T$ , and (2) in conjunction with  $R, S, \dots, Q$  is irrelevant to  $T$ . The following example of this fallacy is given (p. 37):

*Case 3.12:* In the early '70's, a doll was being sold in stores in Ontario which was found to have the unsavory feature of allowing a small but pointed spike to protrude if the head of the doll were removed. Tests showed that this feat was manageable by infants. When parents discovered this danger, they complained to the Department of Consumer and Corporate Affairs. Informed of these complaints, a spokesman for the company which manufactured the doll stated: "All of the legislation in Canada isn't going to protect a child from the normal hazards of life."

To analyze this and similar cases of the fallacy of irrelevant reason, the first step, according to Johnson and Blair (pp. 37-38), is to identify the conclusion of the argument, which is not explicitly stated in the discourse given in the case.

Once again, we have to identify the implied conclusion: "It would be inappropriate to draft legislation seeking to prevent the manufacture and sales of dolls such as . . . ." But the premise here is relevant to the

conclusion only if we assume that the dolls in question fall under the category “normal hazards of life.” Admittedly, that category is rather broad and hard to define precisely; but one would classify as normal hazards things like busy urban streets, rusty nails left in planks, icy sidewalks, roving dogs, etc. Certainly the bounds of that category would have to be stretched to include within it a plaything such as a doll which, by its very nature, is not supposed to be dangerous in any way. So although the spokesman’s claim was true, the argument is not a good one because the premise is *irrelevant*.

But how does this analysis of the fallacy in this case square with Johnson and Blair’s definition of the fallacy of irrelevant reason?

To see the connection, let’s reconstruct what Johnson and Blair take to be the argument in case 3.12.

- (P1) All of the legislation in Canada isn’t going to protect a child from the normal hazards of life.
- (P2) This doll is a normal hazard of life.
- (C) It would be inappropriate to draft legislation seeking to prevent the manufacture and sales of this type of doll.

Johnson and Blair’s objection to this argument supposedly is that (P2) is false and, therefore, not useful as a premise to support (C). But (P1) is useful only if (P2) is used as a premise. Therefore, (P1) is of no use, that is, it is an irrelevant premise, as part of an argument to support (C).

Hence for Johnson and Blair, whether a premise is relevant or not in an argument depends very much on what other premises are used in it. In fact, they make a general point of this thesis (p. 39):

Relevance (unlike truth) does not inhere in each individual premise but rather in an individual premise taken together with certain other items of evidence or information. The point can perhaps best be seen by imagining the sort of artificial case that makes for dramatic TV fare. The prosecutor asks: “Is the defendant left-handed?” The defense lawyer objects: “But that is irrelevant.” The prosecutor presses on: “But, Your Honor, we shall establish that the murderer had to have been left-handed, so if the defendant is left-handed, that is relevant to the question of whether he could have been the murderer.” Here the connection becomes clear; the relevance becomes obvious with the addition of the new information.

This general point is a good one, and we will have other occasions to emphasize it. Relevance is a dynamic notion, meaning that a proposition that was



(apparently) not relevant before can become relevant when new premises or subarguments are added, as a case develops.

But an immediate problem is that Johnson and Blair's analysis of the fallacy of irrelevant premise conflicts with Damer's analysis of the fallacy of missing the point. For with both Damer's examples of this fallacy—cases 3.9 and 3.10—the fallacy of missing the point only occurs if the nonexplicit premises are left out. Once they are put in, as parts of the argument, the other premise, cited by Damer as “irrelevant” or “missing the point,” becomes “relevant” in precisely the sense defined by Johnson and Blair. This apparent conflict of fallacies presents a riddle that needs to be solved. Johnson and Blair's second fallacy of relevance is defined by them as follows (p. 89):

### RED HERRING

1. In an adversary context, *N* has made a claim, *Q*, that is or implies a criticism of a position that *M* holds or identifies with.
2. *M* responds to *Q* by asserting *R*, which introduces an issue that is not relevant to the acceptability of *Q*, and thereby instigates in the exchange a shift of focus away from the question of *Q*'s acceptability.

The example of this fallacy they cited (p. 87) is a classic case.

Case 3.13: A typical *red herring* was committed by then-Senator Paul Martin, well-known for extolling the virtues of his hometown of Windsor, Ontario. On this occasion, Senator Martin rose to defend Windsor against a slur contained in Arthur Hailey's novel about the U.S. auto industry, *Wheels*. Hailey wrote of “grimy Windsor” across the border from Detroit, “matching in ugliness the worst of its U.S. senior partner.” According to press reports, Martin responded: “When I read this I was incensed . . . Those of us who live there know that [Windsor] is not a grimy city. It is a city that has one of the best flower parks in Canada. It is a city of fine schools, hard-working and tolerant people.”

Martin's first point does tell against Hailey's appraisal, for a city with an attractive flower park cannot be completely ugly. But the Senator didn't continue building his case for Windsor's beauty (as he might have) by extolling its splendid rose gardens and miles of riverfront parkland. Instead he *changed the subject*. Fine schools and hard-working, tolerant people are no doubt an asset, but they have nothing to do with whether a city is fair or ugly.

What is especially interesting about this case is that the first few premises were relevant and it is only the last two tacked on at the end that are irrelevant. Also, these last two premises are topically relevant, because they are both about Windsor, but they are irrelevant in another sense. They are not really useful to prove or even support the conclusion that Windsor is not a grimy and ugly city.

Although Johnson and Blair do not explicitly bring the Aristotelian notion of a dialectical exchange or refutation into their account of relevance, it is evident, especially in their definition of the red herring fallacy, that they see relevance as something to be evaluated in a context of dialogue—what they call an “adversary context”—in which one arguer responds to another’s claim.

## 6. GOVIER: PROBATIVE RELEVANCE

Govier (1992) defined relevance in terms of the truth of one proposition “counting towards” the truth of another. This account has a modern look, appearing to absolve the instructor of having to offer any explanation of antiquated Aristotelian dialectical ideas to students. Instead, the basic notion is how one proposition can be used to prove (probative function) or give evidence that counts toward the truth of another proposition.

Govier (1992, p. 146) defined three types of relevance:

### POSITIVE RELEVANCE

Statement *A* is positively relevant to statement *B* if and only if the truth of *A* counts in favor of the truth of *B*.

### NEGATIVE RELEVANCE

Statement *A* is negatively relevant to statement *B* if and only if the truth of *A* counts against the truth of *B*.

### IRRELEVANCE

Statement *A* is irrelevant to statement *B* if and only if the truth of *A* counts neither for nor against the truth of *B*.

The kind of relevance defined here is called *probative relevance* in Walton (*Inf. Log.*, 1989, p. 78), which obtains where a proposition plays some role in proving or disproving the thesis at issue in an argument.

Govier (p. 147) offered the following examples of positive relevance:

*Case 3.14:* Jones has appendicitis, gout, and cancer of the bladder.  
Jones is not healthy enough to run the 26-mile Boston Marathon.

*Case 3.15:* Basketball is a game in which height is a great advantage.

Basketball is a game for which physical characteristics of players make a substantial difference in people's ability.

*Case 3.16:* In May 1981, the interest rate in the United States was more than 18 percent.

Banks in the United States in May 1981 were earning a good return on the money they loaned.

Govier commented (p. 147) that in each of these cases, the first statement "if true, would provide some reason to suppose that the second statement is true." She also wrote (p. 147) that the first statement is positively relevant to the second statement because, in each case, if the first statement was true it would "constitute evidence in favor of" the second statement.

The following examples of negative relevance are cited (p. 147):

*Case 3.17:* Jogging often results in knee injuries.  
Jogging improves a person's general health.

*Case 3.18:* Between 10,000 and 100,000 deaths are predicted, by doctors and scientists, to result from the Chernobyl nuclear reactor accident in 1986.  
Nuclear reactors are a safe form of energy.

These cases are examples of negative relevance (p. 147) because "if the first statement is true, that is some reason to think the second one is unacceptable."

The following examples of irrelevance are given (p. 147):

*Case 3.19:* Smith is old and fat.  
Smith's views on Chinese politics are unacceptable.

*Case 3.20:* Women give birth to babies and men do not.  
Women are sensitive to people's needs and men are not.

*Case 3.21:* Natural catastrophes such as earthquakes and tidal waves are beyond human control.  
Human beings have no freedom of choice concerning their actions.

According to Govier (p. 147), in all these cases, "the first claim provides no evidence either for or against the second one." Hence in all these cases the first proposition is irrelevant to the second one.

One interesting aspect of Govier's treatment of the notion of probative relevance is that she defines different ways of being relevant in which the truth

of one proposition can constitute a reason for believing the truth of another proposition. One way cited (p. 148) is deductive entailment or “complete support.” Another way is by means of a comparison or analogy (p. 149): “when an analogy holds, information about one case is relevant to another.” Yet another is inductive reasoning (p. 150), where one event is relevant to another because it makes the other event more probable.

The appeal of Govier’s account is that it seems to make relevance a purely logical concept that can be defined in terms of relations familiar in traditional logic, like deductive implication and inductive support. However, van Eemeren and Grootendorst (1992a, pp. 148-156) criticized Govier’s account as being a “straitjacket” (p. 148) that does not do justice to the contextual nature of judgments of relevance. They cite the following case (p. 148), among others, as problematic.

*Case 3.22:* Amsterdam is the capital of the Netherlands.

If Amsterdam is the capital of the Netherlands, Paul will pass his driving test.

Therefore: Paul will pass his driving test.

Van Eemeren and Grootendorst quote Govier (p. 148) as claiming that if the premises of an argument deductively entail the conclusion, they are relevant to the conclusion. But their comment on the argument in case 3.22 is the following remark (p. 148):

This is perfect *modus ponens*, but the truth of the first premise does not contribute to the truth or falsity of the conclusion (nor does it detract from it). No wonder: for this conclusion, this premise is irrelevant.

In case 3.22, the argument is deductively valid, but the second premise is false (presumably because the consequent is not even relevant to the antecedent). Hence, as van Eemeren and Grootendorst point out, the first premise does not “count toward” the truth of the conclusion.

So the question is, in case 3.22, are the premises “relevant” to the conclusion or not, in Govier’s sense? Well in one way, they are, because if the two premises are true, then the conclusion must be true too (since the argument is deductively valid). But it would be hard to see how the premises could be used to prove, support, supply evidence for, or count towards the truth of the conclusion. For the one premise is false, and given that it is, the other is of no value or relevance as a proposition that could be used to prove the conclusion, or even support its being true.

Of course, the basis of the problem here is the general difficulty that classical deductive logic, the modern theory of deductive implication, does not model any concept of relevance that is useful for evaluating arguments where

fallacies of relevance are at issue. So Govier's account of relevance is hamstrung by this general problem of defining "counts in favor of" in some way that usefully depicts relevance. In later chapters, it will become clear how probative weight in supporting a conclusion is an important part of the meaning of relevance. But it will also become apparent why, as indicated in chapter 4, an important distinction needs to be made between irrelevance in an argument and probative weakness (the failure of the premises to support the conclusion adequately). What will become clear is that probative weight of an argument, where the premises "count towards" proving the conclusion, is an important component of relevance, but it is not the whole story.

## 7. HURLEY: ANOTHER VARIANT OF THE DUAL APPROACH

Most accounts, unlike Govier's are content to leave the concept of one proposition's providing evidence to support another as undefined, and simply take it for granted as the basis of their account of relevance. This approach avoids the hard issue, but leads to less trouble in the form of becoming caught up in intractable technical difficulties. Hurley (1994) included eight fallacies under the general heading of *fallacies of relevance*, defined (p. 116) as those arguments where the premises fail to "provide genuine evidence in support of the conclusion" and instead only provide an emotional connection. However, two of these fallacies of relevance are of special interest.

The *fallacy of missing the point (ignoratio elenchi)* occurs where (p. 125) "the premises of an argument support one particular conclusion, but then a different conclusion, often vaguely related to the correct conclusion, is drawn." Hurley (p. 126) offered two examples.

*Case 3.23:* Crimes of theft and robbery have been increasing at an alarming rate lately. The conclusion is obvious: we must reinstate the death penalty immediately.

*Case 3.24:* Abuse of the welfare system is rampant nowadays. Our only alternative is to abolish the system altogether.

Hurley's comments on these two arguments (p. 126) show why he thinks they commit the fallacy of missing the point:

At least two correct conclusions are implied by the premise of the first argument: either "We should provide increased police protection in vulnerable neighborhoods" or "We should initiate programs to eliminate the causes of the crimes." Reinstating the death penalty is not a logical conclusion at all. Among other things, theft and robbery are not capital crimes. In the second argument the premises logically suggest some

systematic effort to eliminate the cheaters rather than eliminating the system altogether.

In the first argument, there is quite a logical leap from the premise to the conclusion. We might say that the given conclusion is the “wrong conclusion” for this argument. Similarly, in the second argument, the conclusion is a “leap” to one alternative, without considering less radical solutions.

The other special fallacy of relevance for Hurley, the *red herring fallacy*, “is committed when the arguer diverts the attention of the reader or listener by changing the subject to some totally different issue” (p. 127). Two examples of this fallacy are given (p. 127):

*Case 3.25:* Your friend Margie says that Tasters Choice coffee tastes better than Folgers. Apparently she is ignoring the fact that Tasters Choice is made by Nestlé, and Nestlé is the company that manufactured that terrible baby formula for third world countries. Thousands of babies died when the dry milk formula was mixed with contaminated water. Obviously your friend is mistaken.

*Case 3.26:* The *Consumers Digest* reports that Sylvania light bulbs last longer than GE bulbs. But do you realize that GE is this country’s major manufacturer of nuclear weapons? The social cost of GE’s irresponsible behavior has been tremendous. Among other things, we are left with thousands of tons of nuclear waste with nowhere to put it. Obviously, the *Consumers Digest* is wrong.

In the first argument, the premises cited, to the effect that Nestlé made the fatal baby formula, may be true. But even if they are, they do not bear on the issue of which coffee tastes better. The same analysis applies to the second argument. Hurley’s remarks (p. 127) make it clear why the arguments in these cases commit the red herring fallacy.

The original issue in the first argument is whether Tasters Choice coffee tastes better than Folgers. The arguer changes the subject to baby formula and infant death and then draws a conclusion about the original issue. In the second argument, the original issue is whether Sylvania bulbs last longer than GE bulbs. The arguer changes the subject to nuclear waste, then draws a conclusion about the original subject. In both arguments, the arguer is said to have thrown out a red herring. If the arguer can entice others to pick up the new topic and begin discussing it or debating it, the red herring will have been rendered even more successful.

According to Hurley's account (p. 127), the strategy of the red herring fallacy is for the arguer to divert the listener's attention to a different issue and then, by presenting a powerful argument on this issue, purport to have won the argument.

This pattern of argumentation in the red herring fallacy is different from the one in the missing the point fallacy. In that fallacy, the conclusion is about the same general issue as the premise, but the argument leaps too quickly to an implausible conclusion, without filling in the missing pieces of evidence that would be required to establish that conclusion from the given premise. With the missing the point fallacy, the problem is that the argument given is too weak. With the red herring fallacy, the problem is that the argument given, although strong enough, is about a different issue.

Hurley's missing the point fallacy depends on some prior grasp of the general notion of one proposition providing genuine evidence in support of another. Also, it requires a judgment to be possible to evaluate when such support is relatively weak, as opposed to being relatively strong (say when more premises, or a different conclusion is/are inserted into a given argument). His red herring fallacy depends on some prior grasp of the notion of an arguer changing the subject in an argument and picking up a new topic. In other words, Hurley's account depends on the notions of probative relevance and topical relevance respectively. His distinction between these two subtypes of irrelevance appears sensible and potentially useful, but everything depends on how these underlying concepts of probative and topical relevance are to be analyzed. In chapter 9, Hurley's distinctions, made in relation to the interesting cases he cited, will be analyzed in depth.

## 8. STRAW MAN AND RELEVANCE

It was already noted in Castell (1935, p. 21) that there seems to be a connection between the irrelevant thesis fallacy and the straw man fallacy. In Castell's case of the criticism of the *laissez faire* principle (case 3.6), the critic accused the *laissez faire* exponent of being mistaken in thinking that we will attain a "social utopia" by letting things look after themselves. This move does represent a fallacy of relevance, as Castell pointed out. But it also seems to be an instance of the straw man fallacy because the position of the *laissez faire* exponent is exaggerated to make it seem more radical than it really is (as far as we know, or are told), and then this distorted and implausible version of the *laissez faire* position is used to refute the argument of the *laissez faire* exponent.

Kreyche (1961, p. 278) defined the *fallacy of ignoring the issue* in a way that makes it seem very closely connected to the straw man fallacy. It is interesting to see that his description of the fallacy of ignoring the issue makes explicit mention of the straw man fallacy (p. 278):

This fallacy consists in either disproving what has not been asserted or proving a point other than the one at issue. In the absence of any solid proof in defense of his own position, a person engaged in a discussion or debate will frequently employ all sorts of distracting techniques as a means of evading the issue, not the least of which is the technique of setting up a “straw man.” The straw man type of argument consists essentially in refuting an opponent by making him responsible, not for something that he actually said or, for that matter, implied, but for some proposition that is allegedly connected with his original statement—one which the opponent himself repudiates. Listen sometime to a political broadcast over television or radio.

Kreyche (p. 278) offered the following example of a debate:

*Case 3.27:* **Senator A:** I cannot agree with you, Senator B, in your claim that *all* of the Republican senators are opposed to administration policy.

**Senator B:** Sir, that is not what I said. What I *did* say was that *some* Republican senators are opposed to the policies of the present administration.

**Senator A:** I don't care what you said, because by your previous statement you *implied* that no honest Republican could (in accordance with his principles) support the policies of this administration.

**Senator B:** Yes, I did say that, Senator, but I didn't imply, as you claim I do, that all Republicans are *actually* opposed to administration policy. To say that none of them (as Republicans) should support the administration is not to imply that all of them are really opposed to it.

Clearly what is at stake in evaluating this debate is the straw man problem of determining whether an arguer's imputed position is what his opponent claims it is.

Several other textbook accounts have also included the technique of setting up a straw man argument under the heading of the tactics of irrelevance, typically used to evade the issue in a dispute, or have seen irrelevance as closely related to straw man.

Damer (1980, p. 99) includes the *fallacy of distortion* (usually called *straw man*) under the heading of *fallacies of diversion*. Distortion is defined (p. 99) as “stating an opponent's point of view or argument in a distorted form, usually for the purpose of making it easier to attack.” Damer also has another fallacy called *assigning irrelevant functions or goals*, “criticizing a policy or program because it does not or would not achieve certain goals that it was never



designed to or expected to achieve” (p. 78). Damer offered the following example (p. 78) of this fallacy.

**Case 3.28:** The following is a summary of a typical conversation between many a college philosophy major and his or her critics:

**Lynn:** Do you really think that philosophy will ever solve all of our problems?

**Owen:** No, probably not.

**Lynn:** Then why are you wasting your time studying it?

The fallacy in this case does appear to be closely related to the straw man fallacy, and at the same time, it does seem to be a diversion away from the real issue or problem that is supposedly being discussed.

Johnson and Blair (1983, p. 89) classified the straw man fallacy as the subspecies of red herring fallacy that is a specific failure of relevance. *Straw man*, according to their definition (p. 89) is an “irrelevant response in an adversary context consisting specifically of attacking a misrepresentation of the opponent’s position.”

According to Bonevac (1990, p. 57), “an argument is a *red herring* if and only if it tries to justify a conclusion irrelevant to the issue at hand.” The straw man fallacy is defined (p. 58) as an argument that “tries to justify the rejection of a position by an attack on a different, and usually weaker position.” But the example Bonevac gives of the straw man fallacy (p. 58) looks very much like it could easily be classified by other textbook accounts as an instance of the fallacy of missing the point or *ignoratio elenchi*.

**Case 3.29:** Suppose that a senator is arguing in favor of a trade bill. He or she may adduce examples of unfair trade practices by foreign competitors, point to a large trade deficit with certain nations, and cite examples of domestic industries losing markets to overseas corporations. These arguments may indicate that there are important problems about trade, but they do not prove that the trade bill should be enacted. To establish that conclusion, one would have to show not only that there are problems but also (a) that the proposed legislation can solve them and (b) that it is better, on balance, than any feasible alternative. Of course, it’s difficult to show these things. This is why straw man arguments are so widespread: It’s easy to substantiate that certain problems need a solution but much harder to show that a particular plan will solve them and, furthermore, that it is the best plan.

For example, this case looks very plausibly like it could come under the heading of the fallacy called by Hurley (1994, p. 125) missing the point.

So here we have a problem. The straw man fallacy does seem to be basically a failure of relevance of the Aristotelian type. Where the straw man fallacy has been committed, it is because there is an issue to be resolved, and each party to the discussion has a point of view—one supports the thesis that represents one side of the issue, and the other takes the opposing point of view. The straw man fallacy arises when the one side distorts or exaggerates the point of view of the other side, focusing his attack on a different point of view that is not really what is at issue. Clearly, then, the straw man fallacy is closely related to the fallacy of diverting an argument away from the real issue to be discussed. So what exactly is the difference, or the dividing line, between the straw man fallacy and the *ignoratio elenchi* fallacy? This problem will be addressed in chapter 7, and clarified to the point where the borderline between the two fallacies can be defined.

## 9. THE CURRENT PREDICAMENT

The problem with the early accounts is that, even though they were on the right track, and basically sensible, in trying to adapt Aristotle's account of the *ignoratio elenchi* fallacy to kinds of arguments and concerns important to modern logic students, their treatments of the subject were too brief. The sketchy examples they gave were not adequate and raised rather than resolved the problem of how to determine, by some clear criteria and evidence, whether an argument is relevant or not, in the sense of relevance required to support a claim that a fallacy has been committed. These early textbooks could not assume that their students would make any sense of the Aristotelian dialectical framework, in which a dispute has a thesis, and one party has taken on the obligation to put forward arguments to support its truth. But they could assume that their students would grasp a decontextualized idea of the truth of one proposition being evidence supporting the truth of another proposition. So it was tempting to reconceptualize the fallacy of *ignoratio elenchi* as the fallacy of irrelevant evidence.

On the other hand, the idea of diversion or red herring, because it does genuinely apply to contexts of argument like political debate and legal argumentation in a courtroom, remained an idea that could be explained to students as an important kind of tactic of deception in significant arguments that would be familiar to them. Hence by using more fully developed examples, the later textbooks tried to resurrect the Aristotelian idea of *ignoratio elenchi* as straying from the issue of a dialogue or diverting the attention of the audience onto a different issue.

The result of these developments was the dual approach. The Aristotelian fallacy of diverting to a different issue and the decontextualized fallacy of irrelevant evidence became two separate fallacies of relevance. The problem

was that there was no agreement on terminology with regard to these fallacies. In fact, the outcome could be called terminological confusion or disarray. The other problem was that it was never very clear in any of the textbooks exactly how relevance was to be defined. Moreover, these two fallacies were characterized in differing ways, one account differing significantly from all the others, which, in turn, disagreed with each other. Instead of these just being two fallacies that were basically failures of relevance, an aggregate of several different fallacies emerged. Lacking any theory or precise definition of relevance, there seemed to be no way of exactly defining where one so-called fallacy should be separated from the others. A typical problem of this sort is posed by case 3.4, where a general proposition like ‘Almsgiving is injurious’ is, in at least one sense, relevant to the particular proposition ‘Giving charity in this case has degraded the participant’, but in another sense, it is not relevant. If the one proposition is relevant to the other in one sense, but not in another, then we are faced with an underlying problem. What does *relevance* really mean in trying to judge in this and other cases, whether a fallacy of *ignoratio elenchi* (or whatever you call it) has occurred?

The basic problem is that there has never been a theory of relevance, as applied to fallacies of irrelevance. Modern logic was never in a position to study, classify, analyze, and evaluate the logical faults and fallacies in the cases cited in this chapter, in any clear, precise, and useful way that could move the field toward unanimity or coherence. The central difficulty with teaching logic as a subject that is supposed to be applied to the critical evaluation of arguments in everyday conversation is the problem of relevance. On the one hand, students learn that formal deductive logic, of the kind they are taught, does not model relevance. On the other, as soon as they start in on the part of the course on fallacies (or informal logic), they learn that relevance is not defined in a clear enough way here either. There is no method providing an objective basis for determining whether an argument used in a particular case is relevant or not. Students learn that relevance is an important, indeed crucial, concept for evaluating arguments of the kind associated with fallacies. They also learn that there are no precise criteria for judging relevance or irrelevance.

The students, or users of logic, once they get far enough into the subject to become clearly aware of the developments outlined above, are put between a rock and a hard place. On the one hand, they believe that relevance is an important, and even a crucial concept, for any logic that claims to do justice to the task of evaluating arguments critically, and seeking out logical errors and fallacies. But on the other hand, they see that formal logic, at any rate of the kind primarily being taught, does not model the concept of relevance. How is one to deal with this problem?

As shown in chapter 3, the modern logic textbooks in fact deal with it quite badly. They consign relevance to the domain of informal fallacies, leaving the concept largely undefined, or sketched briefly in the vaguest terms. Many of

them frankly treat relevance as a wastebasket category in which to toss fallacies that apparently cannot really be explained, except by commenting that a failure of relevance has occurred (end of story). This strange policy is an outcome of curious developments in the history of logic, chronicled in chapter 2.

How could one deal with this problem? There are two ways to get out from between the rock and the hard place. Both have been attempted by logicians in the twentieth century, as briefly outlined in this chapter. One way is to attempt to modify formal logic, in order to make it model, or at least be sensitive to, failures of relevance. This way can be called the semantic approach. The other way is portray relevance as conversational after the manner of the ancient rhetorical manuals. This way is to see relevance as an aspect of how an argument has been used in a particular case (text of discourse) by a speaker who is taking part in a conversational exchange with a hearer (or audience). Both approaches are ultimately needed, the semantic and conversational, and it is only when they are fitted together that a clear, precise, and useful theory of dialectical relevance can be constructed. To begin the ascent toward this theory, the first step is to begin to understand the imbalance of the semantic and conversational aspects in the historical development of the concept of relevance as a tool for the critical evaluation of discourse.

*This page intentionally left blank*

## The Problem of Analyzing Relevance

The central task of the present project is to develop a new theory of relevance and then devise practical methods of judging relevance that derive from the theory. The outcome is to supply not just an abstract theory of relevance, but a useful theory that can be applied to real cases where an argument has been used. Practical methods need to be applied to the text of discourse given in an actual case. The outcome should be an evaluation of the relevance of the argument used in that case, as judged on the basis of the given text and context, to the extent they are known, or can be retrieved.

To get such a method, some underlying structure is required. The problem is how to devise such a structure. Obviously logical reasoning is involved, but standard deductive logic simply does not capture the concept of relevance. On the other hand, the textbook accounts of informal fallacies show that the practical concept of relevance appealed to there is empty. It is a wastebasket category into which arguments are dumped when they fail, or are fallacious, for no apparent reason.

Thus, a technical problem is posed. How can relevance be defined in a structure that can at least potentially be formalized? There are formal relevance logics that could possibly be applied to the study of fallacies of irrelevance. Although there is a wide variety of such formal systems, there is little indication that they can be practically applied to real argumentation. One formal system, called *relatedness logic*, has shown promise of applicability to real argumentation and to fallacies of irrelevance. Chapter 4 will show how this system works and will also show that it is useful. But it will also be shown that this system by itself cannot solve the problem.

Where to turn to solve this problem? As indicated in previous chapters, the techniques of argument chaining and argument diagramming are helpful. But even these techniques cannot explain fully enough how to judge relevance and irrelevance in cases of the various fallacies outlined in chapter 1. In practical logic, or so-called informal logic, the fallacies of irrelevance represent certain arguments that have always had a place of central importance. But these fallacies tend to be emotional appeals that can be relevant in some cases, but that are powerful tactics of distraction, and can be irrelevant in other cases.

Chapter 4 takes us a little deeper into how these emotional appeals work as arguments and how they can fail to be relevant. Going even more deeply into the pragmatics of discourse, chapter 5 presents the Gricean conversational approach to relevance. According to this approach, relevance is a contextual

notion that relates to how an argument is used in a particular case in a goal-directed conversational exchange between two parties. By bringing all three of these lines of advance together, chapter 6 will show how they need to be extended and integrated in a way that can lead to a comprehensive grasp of the kind of structure needed to analyze relevance and irrelevance in argumentation.

## 1. THE PARADOXES

In introductory logic courses, students are taught that the main purpose of deductive logic is to determine in particular cases whether an argument is valid or invalid. Validity is defined along the following lines: an argument is valid if, and only if, it is logically impossible for the premises to be true and the conclusion false.<sup>1</sup> An argument is invalid if, and only if, it is not valid.<sup>2</sup> Thus validity may be seen as a very tight kind of conditional link between the premises and conclusion of an argument. To say that an argument is valid does not necessarily mean that the premises are true, but it does mean that if the premises are true, then the conclusion has to be true too (by logical necessity). So deductive logic, as opposed to the evaluation of arguments, could be described as a fail-safe procedure of inference in the following sense. If an argument is deductively valid, that rules out any possibility that one could ever go by inference, in such an argument, from premises that are true to a conclusion that is false.

It does not take long, however, to see that this definition of validity has a direct consequence that is startling to beginners.

**The Principle of Contradictory Premises:** if an argument contains a contradiction within its premises, that argument must be valid (no matter what the conclusion happens to be).

Applying this principle to a particular case, the following argument, for example, is ruled deductively valid.

---

<sup>1</sup> More precisely, validity is defined for forms of argument, and an argument is said to be valid if it has one or more of these forms. The forms of argument are constructed in such a way that it is not logically possible for the premises to be all true while the conclusion is false. This construction is made possible by the use of variables and constants, as defined within a theory. In particular, it is the way the constants are defined that assures that validity of arguments is determined by their logical form alone.

<sup>2</sup> This too is an oversimplification. Invalidity of arguments cannot be determined, in specific cases, by the form of the argument alone.

Case 4.1: Aristotle was the founder of logic.  
Aristotle was not the founder of logic.  
Therefore, bananas are yellow.

Once introductory students see that, according to the definition of validity, the argument in case 4.1 is valid, they are very puzzled by this result.

This puzzlement can be reduced once the students are reminded that the definition of validity is conditional in nature. Part of the problem is that *valid* is a very positive sounding word—a “success” term—and so the students tend reflexively to draw the inference that if an argument is valid, it is as good an argument (from a logical point of view) as it could possibly be. However, the reminder needs to be made here that a valid argument could have false premises. In such a case, it would not be as good an argument as it could possibly be. It might be highly unpersuasive, as a way of trying to prove something to somebody who doubts the premises. Also, a circular argument, where the premises contain the conclusion, or where a premise is even identical with the conclusion, is a valid argument. For to be sure, if my argument is “Wellington is in New Zealand, therefore Wellington is in New Zealand,” it has to be valid, in the sense that it is logically impossible for the premise to be true and the conclusion false—they are the same proposition. But it is not as good an argument as it could possibly be, particularly if used to try to convince somebody who doubts that Wellington is in New Zealand.

So once students are reminded that to say an argument is valid does not necessarily mean it is good in all respects from a logical point of view (or fallacy-free), they may be reassured that evaluating the argument in case 4.1 as valid is an acceptable policy. Moreover, it is possible to see that this policy is a direct logical consequence of the definition of validity. An argument was defined generally as valid where it is impossible for the premises to be true and the conclusion false. But suppose the argument contains a contradiction within its premises, as in case 4.1. Then it is impossible for these premises to be (collectively) true. Hence trivially, it follows that it is impossible for the premises to be true and the conclusion false. The general justification appealed to is the following principle applied to any pair of propositions A and B you care to choose: If it is impossible for a proposition A to be true, then it is impossible for A to be true and B false. Hence, the inference from A to B must be valid. Q.E.D. It seems then that once we have chosen to define deductive validity in this particular way, the principle of contradictory premises is just part and parcel of our way of defining validity.

Apparent oddities like the principle of contradictory premises seem to be part of the general nature of deductive logic (in its classical guise, as taught to students in introductory level courses), as a limited but nonetheless very useful tool for evaluating arguments. Such apparent oddities can be overcome, at least to some extent, once students are brought to realize that validity is a conditional



concept, and that to say that an argument is valid does not mean that it is perfectly good in every respect as an argument. What conclusions do students draw about logic from these not-so-innocent paradoxical inferences then, and what conclusions should they draw?

One conclusion they should draw, and certainly one they need little encouragement to draw, once they have learned the fundamentals of formal deductive logic, is that formal deductive logic (by itself) simply does not model relevance. At least it does not model relevance of the kind we commonly appeal to in every conversational evaluation of arguments when we say that an argument is critically or logically deficient because some part of it, like a premise or a conclusion, is not relevant, or commits a fallacy of relevance. Another conclusion they should draw is that there is a difference between relevance and sufficiency. If an argument is deductively valid then the truth of (all of) the premises is sufficient for the truth of the conclusion. But that does not mean that the premises are relevant to the conclusion. This distinction is vital because it implies a difference between two kinds of failures an argument can exhibit. An argument can be too weak to adequately support its conclusion. On the other hand, the premises (or possibly even some other parts or alleged parts of it) can be irrelevant. This distinction will turn out to be vital in the analysis of fallacies of irrelevance in chapter 7. In general, what needs to be recognized is that irrelevance, or the failure of relevance, is not (always, or exactly) the same as weakness of an argument in the sense of insufficiency to prove the conclusion.

## 2. RELEVANCE AND CONDITIONALS

The central difficulty with classical formal logic, not only for students learning the subject, but also for those who object to it as a theory of reasoning, is the truth-functional definition of the material conditional. The complex proposition ‘ $A \supset B$ ,’ where the material conditional or “hook” symbol joins two propositions  $A$  and  $B$ , is given the definition pictured in figure 4.1. According to this definition, the compound proposition ‘ $A \supset B$ ’ has the value  $F$  (false) where  $A$  (the antecedent) is true and  $B$  (the consequent) is false. In all other possible cases, that is, where  $A$  and  $B$  have opposite values, or where both are false, the compound proposition ‘ $A \supset B$ ’ is said to be false. This definition of ‘if . . . then’ is extremely puzzling to students unless (or sometimes even if) it is explained very carefully as a technical device. They accept row (2) below and generally do not object too seriously to row (1), but rows (3) and (4) are hard to understand.

	<i>A</i>	<i>B</i>	$A \supset B$
(1)	<i>T</i>	<i>T</i>	<i>T</i>
(2)	<i>T</i>	<i>F</i>	<i>F</i>
(3)	<i>F</i>	<i>T</i>	<i>T</i>
(4)	<i>F</i>	<i>F</i>	<i>T</i>

**Figure 4.1:** Truth Table for Material Conditional

Consider row (4) for example. If both component propositions *A* and *B* are false, then the compound proposition  $A \supset B$  must (by definition) be true. The problem is easily illustrated by an example. Suppose *A* is the false proposition ‘The moon is made of green cheese’ and *B* is the false proposition, ‘Socrates was born in Chicago’. Now consider the compound proposition made up from these components, ‘If the moon is made of green cheese then Socrates was born in Chicago’. If this compound proposition is construed as a material conditional of the form  $A \supset B$ , then on the supposition that both component propositions *A* and *B* are false, the whole compound proposition is true (by the definition in figure 4.1). But this ruling seems absurd, because the two propositions ‘The moon is made of green cheese’ and ‘Socrates was born in Chicago’ do not seem to have anything to do with each other. In a word, they are irrelevant to each other, so how could the conditional proposition formed from them be true? This puzzle is the problem faced by every introductory logic student, and it leaves many of them wondering about the applicability of logic to natural language reasoning, and perhaps even the worth of logic. Logic appears to rest on a device adopted as a technical contrivance, one that may somehow be deeply misleading and confusing if deployed as a part of a theory of reasoning.

As a consequence of the adoption of the material conditional as the conventional way of translating ‘if . . . then,’ certain types of inferences are ruled valid that appear to be deeply puzzling. Consider the following pair, where  $\neg$  is the symbol for ‘not’.

$(11) \quad \frac{B}{A \supset B}$	$(12) \quad \frac{\neg A}{A \supset B}$
------------------------------------	---

Instances of these forms of argument are the following arguments (respectively):

(A1) Socrates is Greek.

Therefore, if bananas are yellow then Socrates is Greek.

(A2) Socrates is not alive.

Therefore, if Socrates is alive then bananas are yellow.

Both of these inferences can easily be seen to be deductively valid, given the definition of ‘if . . . then’ as expressing the material conditional. Consider the first one. We know by definition of the hook ( $\supset$ ) that  $A \supset B$  is only false if A is true and B is false. Otherwise  $A \supset B$  is true. So if we assume that B is true, in a given case, it follows that it cannot be the case both that A is true and B false. Therefore,  $A \supset B$  must be true. Similarly with the second inference. If the negation of A is true, then A is false. Hence,  $A \supset B$  would not be false.

These forms of inference are generally valid in classical deductive logic, of the kind that is regularly taught to introductory students. However, the two example inferences of these forms of argument (A1 and A2) appear to be astounding, or even ridiculous, when they are first encountered as deductively valid inferences. But why should they? Surely because the premise, a statement about Socrates, is not at all relevant to the conclusion, a statement about bananas. What conceivable connection do two such statements have to each other? If they do not have any at all, then surely the one is not relevant to the other.

Of course, the instructor can reply by using several arguments. One is to argue that formal logic is really not about relevance. To follow this up, it can be argued that although the definition of the hook as a truth-functional connective is admittedly a technical contrivance, it is one that has the outstanding advantage of yielding a precise, mechanical test for validity. Moreover, the students can be reminded that, anyway, deductive validity is defined in such a way that it only disallows (as valid arguments) cases where, possibly, the premises are true and the conclusion is false. In addition, it can be pointed out that there are other kinds of formal deductive logics that do model relevance—so-called relevance logics—where astounding inferences, like A1 and A2, are not ruled valid (in those systems). The applicability of such formal logics, however, is a subject of some considerable controversy in its own right.

### 3. RELEVANCE LOGIC AND FORMAL RELEVANCE SYSTEMS

Many formal systems of deductive logic have been proposed with the idea of taking relevance into account in evaluating arguments as valid or invalid. Many such systems were presented in Anderson and Belnap (1975). Initially, these formal systems were designed to eliminate as valid inferences arguments like those in inferences (A1) and (A2) which seem to involve a transition felt to be "irrelevant." But these formalistic constructions proved to be too *ad hoc* to provide any practically useful way of evaluating arguments for relevance, for example, in dealing with fallacies of irrelevance. Next, certain formalistic criteria of relevance—like sharing a variable—were advanced, but these too did not prove to be applicable enough to cases of realistic argumentation to be of much help in evaluating realistic cases.<sup>3</sup>

However, one family of formal systems designed to model relevance took the more direct approach of defining relevance specifically as a relation on a pair of propositions *A* and *B*. According to this approach, there could be different kinds of relevance, depending on how *A* and *B* are related (Epstein, 1979). One kind of relevance defined by this approach is *topical relevance*, meaning that the topics (or subject-matters) that *A* is about are also topics that *B* is about. Another type of relevance defined by this approach is *informational containment*, meaning that the information in the one proposition is also contained in the other. (For an analysis of many such systems, see Epstein 1990). The applicability of some of the most basic variants of these systems to argumentation has been studied in Walton (1982). These systems have been more fully developed in Epstein (1994; 1995). One distinctive type of relevance is that of subject-matter relatedness of propositions. In this sense, to say that *A* is relevant to *B* is to say that *A* and *B* share some subject-matters in common. But how could we define the set of subject-matters of a proposition?

One way proposed by Epstein (1990, pp. 62-70) is the following: Assume that every dialogue or argument is about some identifiable set of topics, *T*. For example, an argument could be about the weather, apples, oranges, or the price of soya beans. *T* can be any set of things you like. Now, each proposition that occurs in the argument can be assigned a subset of this set *T*. The subset assigned to a proposition *A* is called the *subject-matter* (or the set of subject-matters) of *A*. For example, suppose the argument is about the following set of topics: oranges, apples, grapes, bananas, mangoes, and pears. Then, suppose the following proposition *A* occurs during the course of the argument: Bob likes grapes better than bananas. Then the subject-matters of *A* are 'grapes and bananas'. Suppose the following proposition, *B*, also occurs during the course of the argument: Amy likes oranges better than grapes. Then we can say that *A* is

---

<sup>3</sup> Iseminger (1980).

related to  $B$  because  $A$  and  $B$  share at least one common subject-matter, namely ‘grapes.’

We could represent the idea of subject-matter overlap between two propositions  $A$  and  $B$  below, where the left circle represents the subject-matter of  $A$  and the right circle represents the subject-matter of  $B$ . The area common to both  $A$  and  $B$  represents the common subject-matter of  $A$  and  $B$ .

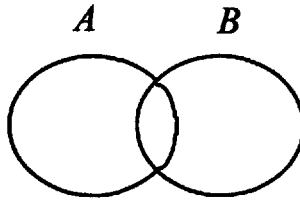

Figure 4.2: Subject-Matter Overlap

This relation of subject-matter overlap between a pair of propositions has certain general properties. First, subject-matter overlap is symmetrical, meaning that if  $A$  is related to  $B$ , then  $B$  is also related to  $A$ . Clearly this property obtains. For if you look at the diagram of the two intersecting circles in figure 4.2, and then change  $A$  to  $B$  and  $B$  to  $A$ , it makes no difference to their relatedness. If ‘Grapes are nutritious’ is related to ‘Grapes are delicious’ then ‘Grapes are delicious’ must also be related to ‘Grapes are nutritious.’

Another property characteristic of subject-matter relatedness is that of reflexiveness. Every proposition must be related to itself. Obviously, any proposition like ‘Grapes are delicious’ will have some subject-matter in common with itself. Hence every proposition is related to itself in virtue of its subject-matter.

A third property is especially characteristic of subject-matter relatedness. This is a failure of transitivity. We say a relation is *transitive* just where the following property holds, for three propositions  $A$ ,  $B$ , and  $C$ .

(TP) If  $A$  is related to  $B$  and  $B$  is related to  $C$ , then  $A$  is related to  $C$ .

Some relations are transitive and others are not. For example, ‘is taller than’ is a transitive relation. If Bob is taller than Jane and Jane is taller than Dave, then Bob must be taller than Dave. But ‘loves’ is not a transitive relation. If Bob loves Jane and Jane loves Dave, it doesn’t necessarily follow that Bob loves Dave.

To see that subject-matter overlap is not a transitive relation, consider the following three propositions:

- A:* Grapes are nutritious.  
*B:* Bob used scissors to cut grapes.  
*C:* My scissors are yellow.

Now *A* and *B* share the common subject-matter 'grapes'. And *B* and *C* share the common subject-matter 'scissors'. But *A* and *C* do not share any common subject-matters. We could represent this idea on the diagram in figure 4.3:

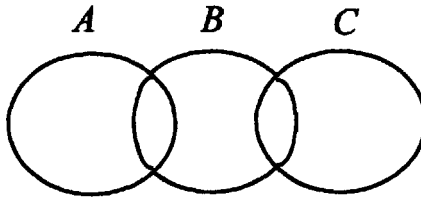

**Figure 4.3:** Failure of Transitivity

*A* and *B* have some subject-matters in common, and *B* and *C* have some subject-matters in common. But it could be, as pictured in figure 4.3, that *A* and *C* are too far apart; that is, *A* and *C* might not have any subject-matters in common at all. In general then, relatedness of subject-matters is not a transitive relation.

Using the concept of subject-matter relatedness, Epstein (1979; 1990) built a system of formal logic that is like the classical deductive logic normally taught in introductory logic courses, except that the connectives are defined in a way that requires relatedness. For example, the inferences in arguments (*A1*) and (*A2*) are not valid in relatedness logic because 'Socrates is Greek' (and also 'Socrates is not alive') has no subject-matter overlap with 'Bananas are yellow'. This way of evaluating arguments as valid or not seems to be a strong advantage of relatedness logic over the usual classical logic because it shows a sensitivity to relevance that classical logic does not have. Moreover, the concept of relevance (topical relevance or subject-matter relatedness) is defined in a clear and exact way. Relevance, at least of one clearly recognizable kind, is defined as subject-matter overlap. This kind of relevance could be generally called topical relevance. But many other specific kinds of relevance are defined by Epstein (1990) as well, like information inclusion, that result in different logical systems.

In general, the value of relatedness logic, and the associated formal systems developed by Epstein (1990) is that they can restrict the validity of worrisome classical inferences like the Principle of Contradictory Premises. For example, arguments like that in case 4.1 would be open to failure because of the failure of some kind of relevance between the proposition, 'Aristotle was the founder of logic' and the proposition, 'Bananas are yellow'. It seems, in general

then, that relatedness logic can be used to rescue formal deductive logic from the criticism that it allows arguments to be valid even when they exhibit what appear to be disastrous failures of relevance.

Unfortunately, however, questions can be raised about just how far such formal systems of deductive logic go, by themselves with no pragmatic supplementation, to deal with fallacies of relevance, as shown in Walton (*Top. Rel.*, 1982, p. 52). In this symbolism, the relatedness conditional,  $A \rightarrow B$  requires (1) that  $A$  and  $B$  have the right truth-values, but also (2) that  $A$  is related to  $B$ , in the sense that they have subject-matter overlap. Although a conditional like  $(A \wedge \neg A) \rightarrow B$  fails to be a tautology in relatedness logic, we can always add a tautology like  $B \wedge \neg B$  to the antecedent, and the resulting proposition,  $((A \wedge \neg A) \wedge (B \wedge \neg B)) \rightarrow B$ , is a tautology.<sup>4</sup> In other words, we can always take an argument that fails to be valid in relatedness logic because of failure of subject-matter overlap and arbitrarily make it valid by adding some harmless proposition. For example, although (A1) is not valid in relatedness logic, the following argument would be:

- (A1A)      Socrates is Greek.  
               Therefore, if bananas are yellow or Socrates is mortal or not mortal, then Socrates is Greek.

Relevance logicians may have different ways of responding to this problem, but in fact, once the problem is pointed out, it will become apparent to students that fallacies of relevance in real cases of arguments cannot be dealt with by this kind of formal system alone.

The root of the problem may be the failure of transitivity. Relevance logic can model certain kinds of relevance, like topical relevance, very well. But when it is applied to the kind of relevance shown to be characteristic of political and legal argumentation,<sup>5</sup> it fails. The reason may be that argument chaining is central to this basic notion of logical relevance, and argument chaining definitely requires transitivity of relevance.

Another way relevance has been defined is as degree of support for a conclusion. For example, Bowles (1990, p. 65) defines relevance using the probability calculus, as follows: A proposition  $A$  is relevant to a proposition  $B$  if, and only if, the conditional probability of  $B$  given  $A$  is greater than a probability value of 0.5. Such a definition has the advantage of being precise because it is based on the probability calculus. Bowles's theory can be stated more generally using the following definitions (1990, p. 65). One proposition can be either favorably relevant to another or unfavorably relevant. In the following probative sense, one proposition can be favorably relevant to another in two basic ways. If

<sup>4</sup> See Walton (*Top. Rel.*, 1982, p. 52).

<sup>5</sup> Some short examples were in chapter 1. Longer ones are treated in chapter 8.

*A* deductively implies *B*, then *A* is conclusively favorably relevant to *B*. If *A* makes *B* more probable, then *A* is inconclusively favorably relevant to *B*. The kind of probative relevance defined by Bowles is a precise, technical concept. But does it correspond to the concept of relevance used in everyday argumentation, legal argumentation, or cases of political debates? According to separate criticisms cited by Woods (1994), Allen (1996), and Hitchcock (1996), it does not. The problems of trying to model relevance and irrelevance in deductive logic have already been indicated. Suffice it to say here that comparable technical problems arise in trying to model relevance and irrelevance using the probability calculus.

Perhaps these technical problems could be avoided by simply appealing to the intuitive notion of probative weight, as used in evidence law. A proposition *A* has probative weight in relation to a conclusion *B* if *A* makes *B* more probable (or more plausible, to get away from a purely statistical notion of probability) than it was before *A* was considered. Then relevance could be defined in terms of probative weight. A proposition *A* is relevant to *B* if *A* throws probative weight onto *B*, in the sense defined above. As was shown in chapter 1, defining relevance in terms of probative weight is precisely the approach taken in the Anglo-American law of evidence. This approach was advocated by Wigmore, who had based his notion of probative weight on ideas from the philosophers John Locke and Jeremy Bentham (Twining, 1985). Both probative weight and argument chaining are vitally important aspects of relevance.

The ultimate problem with this approach is that although the notion of probative weight turns out to be extremely useful in defining relevance, it only takes us so far. The basic reason is that relevance is not always just based on probative weight in a case. Sometimes it is based on what could be called *potential probative weight*. A legal case could illustrate the point. A hair sample found at the scene of a crime, by itself, may neither increase nor decrease the probability that the accused person committed the crime. However, it could be relevant; that is, taken together with other evidence and investigations (e.g., with results of a forensic examination and DNA test), it could carry probative weight with respect to the proposition that the accused person committed the crime. In short, probative weight is not, by itself, always the same thing as relevance. Probative weight combines with chaining forward, as shown by the argument diagram of a case. Contextual factors of other evidence, or the body of evidence or potential evidence in a case, also need to be taken into account.

The leading introductory textbooks, like Copi and Cohen (1990) and Hurley (1994), make no attempt to apply relevance (or relatedness) logic, the probability calculus, or any kind of formal system at all, to evaluating relevance. Instead, the topic of relevance is generally treated, in an informal way, in the section of the text on informal fallacies. The failure of any of these formal systems to be deployed in analyzing fallacies of irrelevance indicates that the



formal deductive and inductive definitions of relevance used in these systems are perceived as being of little practical use in dealing with fallacies of relevance. The bottom line is that relevance logics, despite their formal sophistication, are just not useful in capturing the practical notion of relevance that is central to political and legal argumentation, and to informal fallacies of irrelevance. The next place to look for the missing parts of the concept of relevance is in the treatment of fallacies of relevance in the informal parts of the logic textbooks. The textbook accounts, as shown in chapter 1, tend to take it for granted that these arguments, many of them emotional appeals of one kind or another, can automatically be classified as fallacious simply because they are irrelevant emotional appeals. These assumptions need to be re-examined, in order to learn more about how fallacies are based on a failure of relevance.

#### 4. APPEALS TO EMOTION

Traditionally there has tended to be a perceived dichotomy between logical argument and argument based on emotional appeal. According to this tradition, it was a sufficient refutation to say of an argument, "Your argument is based on emotional appeal and is, therefore, not a logical argument." Hence, it is easily taken for granted that any emotional appeal in argumentation can be presumed to be fallacious or erroneous. This assumption is reflected in the traditional treatment of emotional fallacies in the logic textbooks, where it is generally presumed that not much argument is needed to dismiss *ad baculum*, *ad misericordiam* and *ad populum* arguments, in particular, as fallacies.

However, this assumption may only have been plausible in the past because of a deductivist orientation that set the standard for a good (successful) argument unrealistically high. This standard made deductive logic the exclusive choice for the criterion of formal validity with regard to attempting to analyze fallacies. Many common arguments, we now recognize, are based on a defeasible weight of presumption that enables a conclusion to go forward in a dialogue as provisionally acceptable. It is provisionally acceptable as a basis for action in a given situation where knowledge or hard evidence that would definitely resolve the conflict of opinion is not (practically) available. In such cases, the setting of reasonable burden of proof in nonmonotonic reasoning can rightly define a target of success that makes the argument presumptively reasonable (correct, for practical purposes), subject to default at some future point in the dialogue if an opponent can bring in new evidence to refute it. As a use of practical reasoning in a framework of dialogue, an argument based on emotional appeal could be presumptively reasonable even if it is (in itself) weak and defeasible. In a situation where hard evidence is indecisive, or cannot be brought to bear, an appeal to emotion could be a reasonable guide to prudent

action. The presumption here is that there is a distinction between a probatively weak argument and a fallacious one.

Another presumption is that an argument can be probatively weak, in an absolute sense, yet successfully fulfill requirements of burden of proof as a reasonable, provisionally acceptable argument in a context of dialogue. What is meant by saying that an argument is *probatively weak* in this context is that the premises provide some support to the conclusion, but not very much. There can also be good reasons that would go against the conclusion, or the open possibility that such reasons may come to be discovered in the future. A weak argument is open to critical questioning and doubts, but it is not necessarily so bad that it ought to be rejected or refuted as inherently erroneous or incorrect. By contrast, a fallacious argument is inherently erroneous or incorrect, meaning that it ought to be rejected as a bad argument. The statement 'This argument is fallacious' is a strong kind of condemnation or refutation of an argument. It is a serious charge that needs to be backed up by showing that the argument being criticized is in worse shape than merely being weak, in the sense above.

Generally speaking then, the blanket presumption that emotional appeals in argumentation are inherently erroneous or irrational needs to be challenged, as stated generally in the following thesis.

*Thesis 1:* There is nothing wrong (fallacious, irrational) about emotional appeals *per se* in argumentation. These arguments can be reasonable.

When an emotional appeal is spotted in an argument passage, a critic should not be permitted to leap directly to the conclusion that a fallacy has been committed. There should be a presumption that an appeal to fear, pity, or whatever emotion could be a relevant argument. While identifying an emotional appeal is a good clue in evaluating argumentation, it does not follow automatically that the argument is fallacious. Restraint needs to be shown, in leaping to this kind of conclusion. A good case in point is the *argumentum ad misericordiam*.

*Case 4.2:* In a letter soliciting funds to support medical research for a particular disease, a picture of a young boy is enclosed, showing the pathetic nature of his bruises, injuries, and suffering. A letter, in the boy's handwriting makes a pathetic appeal.

One can say a lot about this case, and the appeal to pity has to be looked at in context. Is the appeal being used to cover up a lack of information on why medical research on this disease really needs funding? How do we know that the funds solicited will really be spent on medical research and not on "administration"? In principle, it seems that the appeal to pity is not illegitimate in such a context. After all, it is a charitable appeal, an appeal to our emotions and human

instincts to help others who are suffering and in need of help. Can we presume to conclude that the use of the *ad misericordiam* argument in this case is a fallacy? We should not so presume. In such a case, an emotional appeal can be a relevant argument because it can be helpful in breaking a tie on whether to go for one practical line of action or an opposed one. Such a decision often needs to be made in a situation where the available knowledge is insufficient to clearly resolve the problem. By practical reasoning, you may either have to do something or nothing (or one thing or another) in a given situation. But you may not have time to conduct an inquiry and collect enough knowledge to be able to decisively decide which is the most prudent line of action. In such a case, appealing to emotional arguments or “gut feelings” could swing a burden of proof one way or the other even though the arguments on both sides are weak and inconclusive.

Another case in point is the *argumentum ad populum*. Political speeches are often used to illustrate this fallacy. Copi and Cohen (1990, p. 103) write that the *ad populum* is the device used to appeal to “patriotic frenzy” by propagandists and demagogues, even citing the speeches of Hitler as the “classic example”. But can we presume, in a democratic system of government, that a political argument that appeals to the opinions, accepted beliefs, or enthusiasms of a majority of the population is a fallacious argument? I do not think so, and indeed it would seem that to so argue would go against the basic principles of the democratic system. Of course, lashing a crowd into tumultuous enthusiasm instead of looking at the relevant evidence on both sides of the issue to be discussed is something else again. But in principle, an *ad populum* argument that appeals to popular sentiments should not be discounted, or classified as fallacious, for that reason alone.

Another often-cited culprit of the textbooks is the commercial advertisement message. Copi and Cohen (1990, p. 103) is typical among the logic textbooks denouncing commercials as users of the fallacious *ad populum* argument:

Those who rely most heavily upon arguments *ad populum* are now to be found in advertising agencies, where the use of that fallacy has been elevated almost to the status of a fine art. Every attempt is made to associate some produce being advertised with things of which we can be expected to approve strongly, or which excite us favorably. The breakfast cereal is associated with trim youthfulness, athletic prowess, and vibrant good health; whiskey is associated with luxury and achievement, and beer with high adventure; the automobile to be sold is associated with romance, riches, and sex. Every device, appealing to sight and sound and smell, is brought to bear: the men who use the advertised product are clear-eyed, broad-shouldered and distinguished; the women are slim, lovely, very well-dressed—or hardly dressed at all. Advertisers, as we

know well, often sell us daydreams and delusions of grandeur. So clever and persistent are the ballyhoo artists of our time that all of us are influenced in spite of our resolution to resist.

This condemnation may seem a little naive, however, when you ask the question, What is the purpose of a commercial supposed to be? Is it supposed to present a balanced critical discussion of the strong or weak points of the product? Is it supposed to be a scientific investigation to prove the product is satisfactory? Is it supposed to be expert or reliable advice to show you that buying the product would be a wise policy? Anyone who thinks the answer is 'yes' to any of these questions is very naive for we all know that the purpose of a commercial is unabashed, partisan selling of the product. The basic goal seems to be to attract the potential buyer's attention and convey a positive attitude toward the product. Who is to say that these goals are inherently illegitimate or that carrying them out using argumentation is "plainly fallacious" per se?

Copi and Cohen retreat somewhat from making this unconvincing claim outright, by conceding that an emotional appeal in a commercial is not necessarily an argument (p. 103):

Of course, the mere association of the product and the emotion is, by itself, no argument—but an argument *ad populum* commonly lies not far beneath the surface. When advertisers make claims about their product designed to win our emotional approval, and when it is suggested that we ought to make the purchase *because* the item in question is "new" or "sexy" or "best-selling", or is associated with wealth or power—the implicit claim that this conclusion follows from those premises is plainly fallacious. The widespread appeal of certain products does not prove them to be satisfactory; the popular acceptance of a policy does not show it to be wise.

Even where an appeal to emotion in a commercial message is an argument, it should by no means be taken for granted that it is fallacious because it does not prove that the product is satisfactory, or that it does not show that buying it is a wise policy. To hold commercials to such lofty standards of success and failure is not only unconvincingly idealistic, but it seems to miss the point of what commercials are all about. They are partisan appeals meant to sell products in a frankly biased way, and people generally are quite aware of that. They are not expecting *Consumer Reports* or 'wise policies' in commercials. Everyone knows, or ought to know, that there is a difference between a program like *Marketplace*, which offers consumer advice on products that have been tested, and commercials that promote a product. To hold the one type of dialogue to the standards of the other is a kind of pragmatic shift or confusion between different types of discourse.

Arguments based on popular opinion or sentiments have two sides. They have often been condemned by philosophers who have said, "Popular opinion is always changing. At one time, people believe one thing, and then ten years later, they believe the opposite thing. Especially in North America, popular opinion on what is acceptable or right changes very fast, and often unpredictably." According to this skeptical view, popular opinion could be compared to the *herd* concept, a kind of headlong rush to fall in with whatever is "trendy," unguided by any real intelligence or rational thought.

But there is another side. In the absence of hard knowledge, it is often presumptively reasonable to act in accord with the popularly accepted way of doing things, if you have no good reason for departing from it. For example, if you are going to a football game in a foreign city where you can't read the signs at the railway station, it may be a good idea to follow the crowds who are all heading to one end of the station. If you have no other information readily available, it may be prudent to follow the crowd, on the assumption that many of them are also going to the game. Of course, so to proceed would be on the basis of a weak (defeasible) argument that could be wrong. But in the circumstances, based on considerations of burden of proof and the practical need for action, the argument could have a reasonable basis, and be relevant.

The worth of popular opinion is always debatable. But as a defeasible kind of argumentation, the *argumentum ad populum* is not so inherently bad or erroneous in itself that it should be declared fallacious whenever used. An emotional argument can be helpful in resolving a conflict of opinions on what is the best course of action in conditions of uncertainty. Even if it is a weak argument and defeasible, it still may be relevant, because it provides a reasonable basis for making a presumption as a provisional guide to prudent action.

The following conclusion can be drawn from our discussion and defense of Thesis 1.

*Conclusion 1:* When arguments, like the *ad misericordiam* and *ad populum*, that appeal to emotions are said by a critic to have been used wrongly, the critic should have to show why.

This conclusion shifts the burden of proof onto the critic to distinguish between the fallacious and nonfallacious instances of uses of emotional appeals in argumentation.

Before leaving the subject of defeasibility, it is appropriate to introduce another fallacy that will be of some importance later. According to Hamblin (1970, p. 28), *secundum quid*—in Greek, *para to pe*—means 'in a certain respect,' and refers to qualifications that may be attached to a generalization. The *secundum quid* fallacy, as treated in the logic textbooks, could be described as the kind of case where an argument is faulty because appropriate

qualifications to a generalization have been overlooked. A typical example is the common textbook case cited in Walton (*Arg. Schemes*, 1996, p. 136).

*Case 4.3:* Everyone has a right to his or her own property.  
Therefore, even though Jones has been declared insane, you had no right to take away his weapon.

The fallacy is the failure to recognize that the generalization in the premise is a defeasible one, subject to qualifications that would apply in some cases, for example, the one cited in the second premise. The relationship between this fallacy and the Aristotelian fallacy of wrong conclusion, often taken to be the central fallacy of irrelevance, will become more evident in chapter 7.

## 5. APPARENT RELEVANCE

Although there is nothing wrong per se with emotional appeals as arguments, there is a problem. Because these arguments are subject to default, sometimes they turn out to be stronger than we thought, once the evidence comes in, and other times weaker than we thought. It requires care not to overestimate or underestimate the weight of commitment that should be invested in one of these arguments. Appearances can be misleading.

When emotions are heightened in argumentation, it becomes easier to give in to bias, according an argument more or less weight than it really deserves. Relevance is an important factor here. An emotional appeal may be an argument with little or no real relevance to the issue of a discussion, but because of its emotional impact on the respondent, the respondent may be inclined to presume that it is relevant. Because of the emotional impact, the respondent may try to respond to it as though it were relevant even though if he were to think twice, he might be able to see that the appeal is of questionable relevance. Such arguments, therefore, often appear relevant when they are not.

The general nature of the practical problem with the use of emotional appeals in argumentation is expressed in Thesis 2:

*Thesis 2:* When emotions are heightened in a dialogue exchange, irrelevance in argumentation is less likely to be perceived as a dialectical failure by someone involved in the exchange.

Arguments that are beside the point, but have emotional appeal, are likely to carry more weight than they deserve. This factor is a question of how an argument appears to someone who is involved in a dialogue in which that argument occurs. An emotional appeal often creates an aura of urgency, so that

the respondent somehow feels obliged to respond to it strongly. This often has a discomobulating effect on a discussion and turns it away from the real issue.

Thesis 2 is a practical explanation of how emotional appeals of the four species cited here can be fallacies, in the sense of arguments that can deceptively seem to be correct when they are not. Part of the problem with fallacies is the practical one of teaching students how they function as deceptive tactics that are commonly and effectively used to fool people in argumentation. However, Thesis 2 is not purely descriptive or psychological in nature. It is a functional question of learning how the fallacies are used as tactics of persuasion in a context of discourse. Once we learn this, we can raise a “red flag” or warning signal when we encounter these tricky types of arguments that may indicate the presence of a fallacy. One needs to be alert that in certain types of situations, it is easy to be trapped, to be caught up in an apparently appealing and attractive, but dangerous line of argumentation.

A good case in point is the *argumentum ad hominem*, the use of a personal attacking argument. An *ad hominem* attack brings an argument to a personal level, and the respondent attacked may feel compelled to reply strongly, to avoid appearing to concede guilt. However, once the argument is brought to the personal level, it is often very tempting for the respondent to reply *tu quoque*, with another *ad hominem* attack directed against the attacker. Once this happens, the sequence of argumentation often descends, by a kind of *glissement* or gradual shift, into a quarrel.

The trouble is that the original argument may quite rightly have been supposed to be a critical discussion of some particular issue, according to the agreements the participants originally made. Once personal attacks begin to predominate, however, there may no longer be any real discussion of that issue taking place. Personal quarreling is generally an inefficient way of conducting a critical discussion of some (relatively impersonal) issue. However, such a shift away from relevant argumentation that would contribute to the resolution of the conflict of opinions in the critical discussion may not be perceived for what it really is. The reason is that the emotional personalization of the argument may be very colorful, interesting, and stimulating. Its value as entertainment may mask its dubious relevance as a contribution to the thread of argumentation in the discussion that the participants are supposed to be engaged in. In the case below, Wilma and Bruce are engaged in a critical discussion of whether abortion is morally right:

*Case 4.4:* **Bruce:** Well, what about you, Wilma? You had an abortion last year. And you argue that abortion is not right?

**Wilma:** You are in no position to comment on these things. You are a man, and a man cannot experience an unwanted pregnancy.

*Bruce:* You're just trying to cover up your own lack of integrity on this issue.

In this case, things are getting worse as the argument gradually shifts away from a discussion of the abortion issue toward a personal quarrel between the two participants. Bruce's initial move is not an entirely unreasonable type of circumstantial *ad hominem* argument, put in the form of a question. Wilma's reply escalates the quarrelsome element by using a *poisoning the well* type of *ad hominem* argument that suggests that Bruce is inevitably and inescapably biased on this subject. This move has the effect of closing off the discussion by the tactic of barring Bruce from taking any further credible part in it. Bruce's second move escalates the personal element a step further by accusing Wilma of being dishonest, using the abusive (direct) type of *ad hominem* attack. As the quarrel becomes more personal, it becomes more and more difficult for the participants in the dialogue to get back to the critical discussion.

Caught up in this type of emotional exchange, it becomes more difficult for an arguer to perceive emotional arguments as irrelevant, and less difficult to give them more weight than they really deserve. The fallacy is tricky to spot in such cases because the emotional argument was initially not unreasonable as a move in the dialogue. Then, as things get rolling, the sequence of dialogue is deflected more and more away from resolving the conflict of opinions in the original critical discussion. Diagnosing the problem in such a case is partly a matter of shifting appearances. Personal attack is not inherently fallacious in argumentation, but it can often go wrong, while still seeming to be right to the participants in a dialogue, because there has been a subtle and gradual shift.

The conclusion to be drawn from our discussion of Thesis 2 is that in emotional appeal arguments like the *ad hominem*, the fallacy or failure is to be diagnosed as a straying away from the point of the original dialogue. It is a failure of conversational relevance.

*Conclusion 2:* In arguments based on emotional appeals, the fallacy or failure may be tricky to diagnose because it involves a shift, which can be gradual, away from contributing to the goals of a discussion the participants were supposed to be engaged in.

Such a shift can explain the traditional idea that a fallacy is an argument that seems to be valid. An emotional exchange can seem to be legitimate and appropriate as part of a dialogue interaction like a quarrel. But appearances can be misleading here, as the argumentation really needs to be evaluated by the standards of the type of dialogue the participants were originally supposed to be engaged in, like a critical discussion.



## 6. PRAGMATIC CONVERSATIONAL FAILURES

Emotional appeals can be made for various purposes in argumentation. For example, in a speech at a funeral to honor someone recently deceased, appeal to emotion is not out of place. In a scientific proof in the context of a scientific inquiry or demonstration, however, appeals to emotion are not generally in keeping with the goals and methods of this type of argumentation. In a critical discussion, arguments based on appeals to emotion can often carry a presumptive weight which is legitimate in contributing to the goal of resolving the conflict of opinions, but they have a way of shifting, or becoming irrelevant when too much weight is put on them. This brings us to our third thesis concerning the four emotional fallacies we set out to study.

*Thesis 3:* The four emotional fallacies need to be evaluated by seeing them as dialectical failures. You have to look at the context of dialogue.

Typically, the problem with these four fallacies stems from the fact that the context of dialogue is that of a critical discussion of some particular issue, and the emotional appeal is not relevant within the framework of the rules for that critical discussion. To judge relevance in a particular case, however, we have to evaluate the argument as a speech act that has a place in the larger framework of the critical discussion.

The *argumentum ad baculum* is one type of case in point. An *ad baculum* argument is typically a threat; however, in some cases, an appeal to fear, or use of scare tactics, can also be called a type of *ad baculum* argument without a threat being made—such arguments could perhaps be called *ad metum* or *ad phobiam*, but they can be classified as subspecies of *ad baculum* argument. However, in the typical case of *argumentum ad baculum*, a threat is made by a proponent to a respondent in a dialogue, and it is very often an indirect threat, which has the surface appearance of a warning. In such cases, the argument takes the form of an indirect speech act that is overtly a warning, but covertly a threat.

In the following case, the speech event is the meeting of a section in a corporation, called by the administrative head of the section. He is putting forward a proposal for a reorganization of the section, and in his speech, he is trying to convince the section members in the group that his proposal would be a good thing for the company.

*Case 4.5:* **Section Head:** As part of this plan for reorganization, some jobs will have to be restructured. Of course, all of you should be warned that your jobs could be vulnerable, and if any of you

disagrees, or fails to vote for my new proposal, it could be your job that gets cut.<sup>6</sup>

In this case, the frightening thing for the employees is that they know, or have good reason to think, that the section head may have the power to fire them. Therefore, from their point of view, they see his “warning” as a threat. Overtly, his speech act is a warning, but the employees (with justification) interpret it as a covert threat. Indeed, in this case, the threat is so transparent that it is somewhat heavy-handed and even ludicrous. But a threat is not a fallacy. Indeed in negotiations, for example between union and management bargaining units, indirect threats are a commonplace part of the bargaining, for example, “If management doesn’t back off on that one, the picketers will be out on the line tomorrow.” Overt threats are generally not allowed in such negotiations, but covert threats are plentiful and are generally accepted as part of the negotiations, at least in many cases.

However, in case 4.5, the problem is that the section head is supposed to be convincing his audience that his proposal is right, presumably based on good evidence to the effect that his plan would be good for the company. This type of speech can be construed as a type of critical discussion, a type of dialogue that has standards of rational argumentation of a clearly defined kind (as shown in chapter 5). But the problem is that the threat cuts off the employees’ ability to contribute in an unhampered way to the continuation of that critical discussion. Indeed, the threat has the effect of closing off the critical discussion altogether. It is a kind of unilateral cutting off of the flow of critical discussion by impeding the argumentation of the *contra* side. In this case, the critical discussion is used as a normative model of the kind of discourse the participants were supposed to be engaged in. At least we can say this to the extent of what we know or can presume from the given information in the particular case. But the fallacy is not viewed exclusively in the light of the critical discussion.

As noted, indirect threats are a commonplace part of bargaining in negotiations between union and management. In such a context, an indirect threat is not only a kind of practical argumentation that is normally expected, but it is also not necessarily a fallacy. Rather, the threat is fallacious from the point of view of the critical discussion. The explanation of how the indirect *ad baculum* functions as a deceptive argument that has some plausible appearance of being nonfallacious lies in the shift from the critical discussion to the negotiation dialogue. The negotiation dialogue supplies a given ambiance or context in which the threat appears less obviously outrageous or inappropriate than if it were to occur in a case where the argument had no semblance of a

---

<sup>6</sup> A somewhat similar case can be found in Irving M. Copi, *Introduction to Logic*, 7th ed., New York, Macmillan, 1986, p. 128 (exercise question number 29).

negotiation. Hence, it is the combining of the two perspectives that explains how the *ad baculum* argument functions as a plausible deceptive tactic.

It is precisely in this type of case, then, that we can justifiably say that an *ad baculum* fallacy has been committed. The threat has no place in the critical discussion. As a move in the discussion, it is irrelevant and even goes contrary to its goals by inhibiting its proper progress. But what made the *ad baculum* argument fallacious was not merely the fact that a threat was made—however immoral, illegal, impolite or nasty such a threat might be. What made it fallacious was the indirect speech act, a tactic used in this case to shift the line of argumentation away from fulfilling the goals of the critical discussion.

The conclusion to be drawn from our discussion of this case is that a certain kind of evidence is needed to support the conclusion that the use of an emotional appeal is fallaciously irrelevant in a given case. The first was to determine what type of dialogue the participants were supposed to be engaged in. The second step was to look at how the speech act was actually brought forward in the given case and used in relation to the requirements of that type of dialogue. The third step was to look under the surface to see whether at a covert level, there was a shift away from contributing to the legitimate goals of the dialogue.

**Conclusion 3:** In evaluating uses of appeals to emotion in argumentation, the evidence required to prove an argument fallacious has to come from the context of dialogue.

The problem of evaluation in such cases turns on an examination of how the speech act was used as a part of a larger context of dialogue in which that speech act has a functional place. However, when there is a shift, especially a covert shift, away from the original context of dialogue, we get the right conditions for fallacies and deceptions.

The evidence from informal fallacies suggests that the notion of relevance that they need to be based on comes from a context of dialogue. Of course, this thesis was already suggested by the considerations on political and legal argumentation treated in chapter 1. Relevance appears to be based, at least partly, on rules governing a productive discussion. Even in chapter 1, it was somewhat evident that relevance is useful by setting boundaries for a discussion or meeting designed to solve a problem or resolve an issue. Going into greater depth on fallacies of irrelevance has pointed in the same direction. The way to go, in order to adequately analyze the notion of relevance in these four fallacies of irrelevance, is not the semantic route of attempting to use formal deductive relevance logic. The best approach is the conversational route of portraying relevance as contextual to a dialogue or discussion framework. Relevance needs to be viewed as a property of how an argument is used in a given case by a

speaker who is taking part in a goal-directed conversational exchange with a hearer.

## 7. CONVERSATIONAL IMPLICATURE

A *conversational implicature*, according to the theory of Grice (1975) is an inference drawn by one party in a conversation from what another party says (even though the second party does not state the conclusion of the inference explicitly), using certain general features of the conversation. These features are comprised of one general principle and four conversational maxims (Grice, 1975, p. 67):

- Cooperative Principle:* Make your conversational contribution such as is required, at the stage at which it occurs, by the accepted purpose of the talk exchange in which you are engaged.
- Maxim of Quantity:* Make your contribution as informative as is required for the current purposes of the talk exchange.
- Maxim of Quality:* Try to make your contribution one that is true.
- Maxim of Relation:* Be relevant.
- Maxim of Manner:* Be perspicuous.

Under the maxim of manner, Grice included four submaxims (p. 67): avoid obscurity of expression, avoid ambiguity, be brief, and be orderly. To explain what he meant by relevance, Grice (p. 68) offered the following remark.

I expect a partner's contribution to be appropriate to immediate needs at each stage of the transaction. If I am mixing ingredients for a cake, I do not expect to be handed a cookbook, or even a pot-holder (though this might be an appropriate contribution at a later stage).

Judging from this remark, it seems that the Cooperative Principle (*CP*) is very important in determining or explaining what relevance is. It seems that relevance is a matter of a conversational contribution being right not only for the purpose of the conversation generally, but being useful at the particular stage of the conversation that the speaker and hearer are actually engaged in.

Grice offered the following three cases to illustrate how the maxim of relevance is used to give rise to conversational implicatures:

- Case 4.6:* Suppose that *A* and *B* are talking about a mutual friend *C*, who is now working in a bank. *A* asks *B* how *C* is getting on in his job, and *B* replies, "Oh quite well, I think; he likes his colleagues, and he hasn't been to prison yet." At this point *A* might well inquire

what *B* was implying, what he was suggesting, or even what he meant by saying that *C* had not yet been to prison. The answer might be any one of such things as that *C* is the sort of person likely to yield to the temptation provided by his occupation, that *C*'s colleagues are really very unpleasant and treacherous people, and so forth (p. 65).

*Case 4.7:* *A* is standing by an obviously immobilized car and is approached by *B*, and the following exchange takes place:

*A:* "I am out of petrol."

*B:* "There is a garage around the corner."

*Gloss:* *B* would be infringing the maxim "Be relevant" unless he thinks, or thinks it possible, that the garage is open, and has petrol to sell; so he implicated that the garage is, or at least may be open, and so on (p. 70).

*Case 4.8:* *A:* "Smith doesn't seem to have a girlfriend these days."  
*B:* "He has been paying a lot of visits to New York lately."  
*B* implicates that Smith has, or may have, a girl friend in New York. *Gloss* is unnecessary in view of that given for the previous example (p. 70).

In case 4.6, *A* draws the conclusion that *C* is a potentially dishonest person or at any rate, draws the conclusion that *B* is suggesting or implying that this proposition is true. But how? *B* does not explicitly state such a proposition. Grice's explanation is that when the speaker flouts (blatantly violates) a maxim, he may do so because he knows the hearer will recognize that the flouting is intentional, and draw a conclusion from this recognition. Grice illustrated the point, using the maxim of relevance (p. 69):

I am now in a position to characterize the notion of conversational implicature, a man who, by (when) saying (or making as if to say) that *p* has implicated that *q*, may be said to have conversationally implicated that *q*, *provided that*: (1) he is to be presumed to be observing the conversational maxims, or at least the cooperative principle; (2) the supposition that he is aware that, or thinks that *q*, is required in order to make his saying or making as if to say *p* (or doing so in *those* terms) consistent with this presumption; and (3) that the speaker thinks (and would expect the hearer to think that the speaker thinks) that it is within the competence of the hearer to work out, or grasp intuitively, that the supposition mentioned in (2) is required. Apply this to my initial example, to *B*'s remark that *C* has not yet been to prison. In a suitable setting *A* might reason as follows:

“(1) *B* has apparently violated the maxim ‘Be relevant’ and so may be regarded as having flouted one of the maxims enjoining perspicuity; yet I have no reason to suppose that he is opting out from the operation of the *CP*; (2) given the circumstances I can regard his irrelevance as only apparent if and only if I suppose him to think that *C* is potentially dishonest; (3) *B* knows that I am capable of working out step (2). So *B* implicates that *C* is potentially dishonest.”

*B*'s statement that *C* hasn't been to prison yet is not relevant to the rest of the conversation. It appears that *B* may be violating the (*CP*) and/or the maxim of relevance. But *A* has no evidence that *B* is opting out of the conversation, so as an alternative, he can try to make what *B* says relevant. *A* puts two and two together—*C* is working at the bank and going to jail would most plausibly, in those circumstances, be an outcome of some dishonest practice. *A* draws the conclusion that *B* is saying (or implying) that *C* is potentially dishonest.

In case 4.7, *B*'s reply is relevant to the previous conversation. However, *A* draws additional inferences from what *B* says. In particular, according to Grice, *B* draws the conclusion that the garage is open and has gas to sell (or at any rate, that *A* thinks it may be open). In this case, the conversation is a type of information-seeking dialogue. *A* has a practical problem and is asking *B* for help in the form of information on where he can conveniently get gas. *B*'s reply is relevant because a garage is normally a place where you can get gas. However, if *B* were to know that this garage was closed or did not serve gas, his reply would not be helpful—it would not contribute cooperatively to the conversation—in fact, it would mislead *A* and be obstructive to *A*'s solving his problem.

In case 4.8, we are not told, and we can't really guess, what type of conversation the participants are engaged in. It may be just a casual conversational exchange with no particular purpose. But even here *A* can make a connection. *B*'s remark would be relevant if Smith's visits to New York were for the purpose of visiting a girl friend there. *B*'s remark could provide a possible explanation of his not appearing to have a girlfriend while paying a lot of visits to New York. Once again, *A* can put two and two together, exploiting the assumption that *B*'s remark is relevant to the prior conversation.

## 8. PROBLEMS WITH THE GRICEAN APPROACH

The Gricean approach shows great promise for two reasons. First, it seems to model relevance in a pragmatic way that is consistent with the pragmatic and contextual idea of relevance on which the informal fallacies are viewed as faults of relevance. Second, it holds the promise of allowing us to keep formal deductive logic as it is and explain the various paradoxes and puzzling

inferences cited as conversational failures of relevance relating to how an argument is used in the conversational context of a case. The Gricean analysis of conversational implicature shows that people are aware of, and can recognize, failures of relevance in everyday conversational exchanges. But relevance, so understood, is not something that is a semantic property of a single inference. It is a conversational concept that relates a reply to a question and/or to prior moves in a sequence of argumentation used in a conversational exchange. In such a context, as Grice showed, participants can even exploit what both clearly recognize as a failure of relevance to draw conclusions from this recognition. But implicatures are not deductively valid arguments of the kind typically studied in formal logic. They are presumptive guesses or conjectures, very much like the kinds of inferences characteristic of those used in the cases 4.6, 4.7, and 4.8, illustrating the various fallacies of relevance. It appears, then, that the Gricean conversational route is the way to go if we hope to have a method of evaluating arguments with respect to the question of whether fallacies of relevance are committed or not. Nevertheless, there are some problems in the way of pursuing this route.

One problem is that Grice doesn't really define relevance or tell us in any precise way whether it exists or not in a given case. His rule of relevance is simply, "Be relevant!" But what does that mean, or amount to, in a specific case, where there is a problem of whether an argument is relevant or not? We are not told. In fact, Grice (1975, p. 46) wrote that he found such problems "exceedingly difficult".

... its formulation conceals a number of problems which exercise me a good deal; questions about what different kinds and foci of relevance there may be, how these shift in the course of a talk exchange, how to allow for the fact that subjects of conversation are legitimately changed and so on. I find the treatment of such questions exceedingly difficult, and I hope to revert to them in a later work.

Grice never did fulfill his hope to revert to these problems, and work since Grice (see Dascal (1977) and Berg (1991)) has not yet led to definitive solutions to them. According to Dascal (1977, p. 310), Grice left the maxim of relevance in "a disparagingly vague state".

Another problem, cited by Dascal (p. 311), is that the concept of relevance also appears partly to govern the other Gricean conversational maxims, leading Dascal to suggest that the *(CP)* itself seems to operate as if it were a principle of relevance rather than a principle of cooperation. Once again, Grice admitted (1975, p. 49) that he was not in a position to justify the *(CP)* until he could be "a good deal clearer about the nature of relevance and of the circumstances in which it is required". So Grice even admits that he has not given a clear and precise definition of relevance in a conversational exchange. It

seems hard, however, to define relevance without invoking the (*CP*) or even defining relevance in terms of the (*CP*), or some equivalent principle. For example, Berg (1991, p. 412) defined relevance as “usefulness with regard to the conversational goals or objectives of the conversants”. This seems to define relevance by making it equivalent to the (*CP*), but he suggests that “it is only because the Maxim of Relation serves as a catch-all for those aspects of the (*CP*) not explicitly falling under the other maxims”. However, this equivalence is a problem. If the (*CP*) itself defines relevance, then why have a separate Maxim of Relation?

More generally, the problem is that the Maxim of Relation is essentially blank, in Grice’s framework, so that the difference between it and the (*CP*), if any, is impossible to ascertain. Quite generally then, the problem is that Grice’s account of relevance gives no clear definition of relevance, or any precise criteria for identifying failures of relevance in specific cases, that could be used in a logic course to help students evaluate fallacies or faults of relevance in argumentation.

The final problem with the Gricean methodology is that it is not applicable to real cases where argumentation occurs in everyday conversations, of the kind cited in the logic textbook treatments of fallacies of relevance. As noted, such arguments occur in different kinds of conversations, and each type of conversation has different goals and objectives. A negotiation type of conversational exchange has different goals, and different means for achieving those goals, from those of an information-seeking type of conversational exchange. Both types of conversational exchanges would, in turn, be different from the kind of exchange of arguments where one party is trying to persuade the other that some proposition is true. Accordingly, relevance needs to be judged differently from a dialectical point of view in different cases, depending on the type of conversational context appropriate for the given case.

The general assessment of Grice’s theory is that it suggests a pragmatic approach that could potentially be used to define relevance. But it falls far short of giving any precise criteria of the kind expected in methods to be used in a logic course that could be used to determine what is or is not relevant in a specific case.

## 9. ARGUMENT DIAGRAMMING

The technique of argument diagramming can be used to represent a given example of chaining of premises and conclusions in argumentation presented in a text of natural language discourse. This technique, widely used already for other purposes in informal logic, is thus also a fundamental tool for making judgments of relevance. Introductory logic textbooks, like (Hurley, 2000) now typically devote a chapter to argument diagramming. In some respects, the



technique is still not in an advanced state of development. There are disagreements about notation and methodology, and some key problems have still not been solved.

One such problem is how to distinguish between linked and convergent arguments. Different textbooks advocate different criteria. The various criteria used have been summarized in (Walton, *Arg. Struct.*, 1996), where a formalization of the method of diagramming is also presented, using Harary's directed graphs (Harary, 1969). The diagramming technique is used to represent the reasoning structure in a given argument found in a text of discourse. An argument diagram has two basic components (Freeman, 1991). One is a set of circled numbers arrayed as points. Each number represents a proposition (premise or conclusion) in the argument being diagrammed. The other is a set of lines or arrows joining the points. Each line (arrow) represents an inference. The whole network of points and lines represents a kind of overview of the reasoning in the given argument, showing the various premises and conclusions in the chain of reasoning. In (Walton, 1996, *Arg. Struct.*, chapter 6), a reasoning structure is modeled as a directed graph, made up of three components: a set of propositions (points), a finite set of inference steps from one point to another, and a function that maps each step into an ordered pair of points.

A relatively simple case of an argument diagrammed in a logic textbook can be used to illustrate in general outline how the diagramming technique works. The following case is very similar to the example in (Hurley, 2000, pp. 66-67) except for some minor changes made to simplify the illustration. Each proposition in the argument below is numbered.

(1) Skating is a wonderful form of exercise and (2) is an excellent form of relaxation, but (3) the hazardous actions of today's rollerbladers present a serious public problem. (4) Rollerbladers are oblivious to traffic regulations as (5) they breeze through red lights and (6) skim down the wrong way on one-way streets. (7) They pose a threat to pedestrians because (8) a collision can cause serious injury. (9) Rollerbladers are even a hazard to shopkeepers as (10) they zoom through stores and (11) damage merchandise.

Following Hurley's analysis (p. 67) the inferential structure of this argument can be set out as follows. (1) and (2) are merely introductory sentences, and can be deleted from the diagram of the argument. The ultimate conclusion is (3). (4), (7) and (9) each provides an independent line of argumentation supporting (3). (5) and (6) are premises supporting (4). (8) supports (7). (10) and (11) are premises supporting (9). The argument diagram representing the whole structure of reasoning is displayed in figure 4.4.

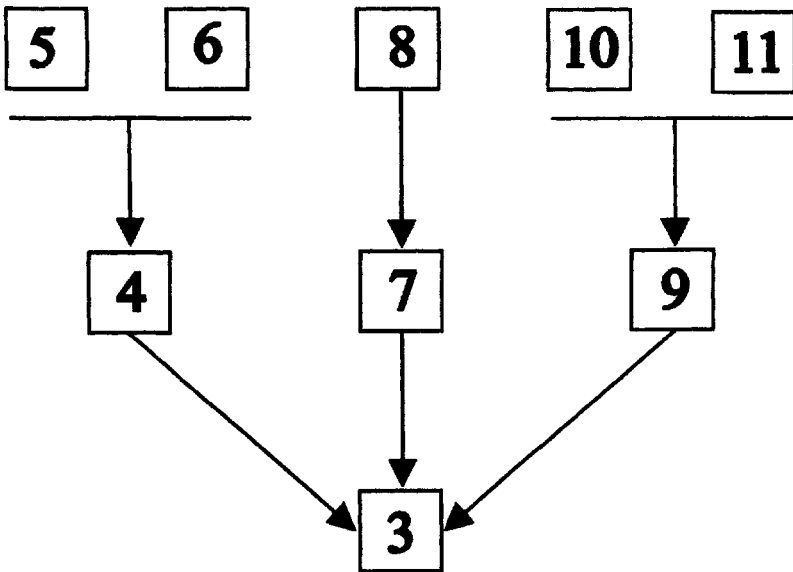

**Figure 4.4:** Argument Diagram of the Rollerbladers Case

This argument diagram shows the kinds of steps that need to be taken to represent the reasoning structure of an argument found in a given text of discourse. First, the text of discourse needs to be tidied up and interpreted. Material not essential to the argument must be deleted. In some cases, implicit premises (or conclusions) need to be added. In some cases, more than one interpretation is possible. In such cases, it may be useful to construct more than one argument diagram. Some cases can be highly complex; figure 4.4 is relatively simple.

The central component in an argument diagram is defined in (Walton, *Arg. Struct.*, 1996, p. 187) as a special kind digraph (directed graph) called a reasoning structure. A graph, in this sense of the word, is a structure made up of a set of points (vertices) and a set of lines (arcs, arrows) joining some points to other points (Harary, 1969, p.9). Graphs, sometimes called “flow charts,” are widely used in various disciplines to model processes or routes of various kinds. For example, the tree structure used to model decision-making problems is a kind of graph. A reasoning structure is a special kind of graph that can be used to represent argument diagramming. A reasoning structure  $R = (P, I, F)$  is made up of the following three components. The first component is a finite nonempty set of points (propositions),  $p_1, p_2, \dots, p_n$ . The second component is a finite

set of steps (arcs),  $i_1, i_2, \dots, i_n$ , called inference steps. The third component is a function  $F : I \rightarrow P \times P$  that maps each step into an ordered pair  $(p_i, p_j)$  of points. A line of reasoning is an alternating sequence of points and inference steps where each inference step goes from one point to another (p. 189). A line of reasoning can come back to the same point it started from, in some instances. In other words, a reasoning structure can be used to represent cases of circular reasoning. The reasoning structure of a given argument can be represented by an argument diagram in the form of a digraph. The argument diagrams in figures 4.4 and 8.2 are examples of such digraphs. The points represent the various propositions (the premises and conclusions) in the argumentation. The arrows (arcs) joining the points represent the inferences from some propositions to other propositions. The reasoning structure is a very simple form of argument diagram that just represents the steps of inference and the various premises and conclusions in a sequence of argumentation. Various other pieces of notation need to be added, in order to represent different characteristics of the argumentation used in a case.

The method of argument diagramming presented in (Walton, *Arg. Struct.*, 1996) is quite simple. A more formally sophisticated method has been developed (Walton and Batten, 1984) to model interesting cases of circular reasoning. The Walton and Batten method is based on the notion of a formal argument system. A formal system is defined (Walton and Batten, 1984, p. 139) as a triple  $F = (P, D, R)$  where  $P$  is a set of atomic propositions,  $D$  a set of  $n$ -ary operators and  $R$  a set of so-called rules or arguments. The idea is that the set of atomic propositions is comparable to the set of facts in a knowledge base, and the operators can be used to make complex propositions out of them. Then the rules can be used to make up arguments from the facts. The same rules can be applied over and over recursively, so we get forward chaining of arguments of the kind that is familiar in knowledge-based reasoning. An interesting problem that can arise in such cases is circular reasoning. This can occur where an argument is chaining forward but then comes back to its point of origin. The problem is how to evaluate such cases as arguments. Are they cases of the fallacy of begging the question, or can circular reasoning sometimes be harmless or benign? To address this problem, many interesting cases of circular argumentation are studied, and a graph-theoretic representation of the argumentation in a formal system is constructed. Informally, the idea can be explained as follows: When an argument is chained forward in a formal system, each of the premises and conclusions at each stage can be represented as a vertex in a digraph. The outcome is that in a given case, where one is presented with a lengthy chain of argumentation that can be expanded by applying rules to facts over and over again, it is possible to represent the whole network of connected argumentation using a digraph. If there is a circle in the argumentation, or several circles, such phenomena will be easily evident from

the digraph. Once you have identified the circles in the argumentation, you can use criteria of evaluation to judge whether the circles represent instances of the fallacy of begging the question (fallacious circularity) or whether they are merely benign circles that do not represent fallacious argumentation.

In the literature, there are various ways of constructing argument diagrams. Freeman (1991) does not use digraphs at all. Instead, simple diagrams that differentiate between linked, convergent, chained, and divergent (multiple-conclusion) arguments are used. Schum (1994) models the argument diagram as a digraph and uses the Bayesian approach of probability theory to assign numerical values to each point (proposition) represented in the digraph. In the system of Walton and Batten (1984), and the comparable but simpler system of Walton (*Argument Structure*, 1996), arguments are modeled using digraphs, but numerical values are not assigned to propositions. Instead, the method of evaluation is to apply criteria of evidential priority to argumentation. This method results in a kind of ordering of the propositions used in an argument. The ordering can then be used to evaluate the argument. For example, some criteria of evidential priority can be shown to exclude certain configurations of circular argumentation, as represented in an argument digraph, as fallacious. Although there are many differences of theoretical representation, the notion of an argument diagram is quite similar in each of these approaches. The technique of argument diagramming has proven its utility in applied logic, and there is universal recognition of it as a useful tool.

New automated tools for argument diagramming have now been developed. *Araucaria* is a software tool developed by Chris Reed and Glenn Rowe to construct an argument diagram from the text of a given argument (Reed and Rowe, 2001). It is based on an argument markup language (AML) defined in an XML document type definition (DTD). It is free software released under public license at the University of Dundee. The user begins by loading the text onto the left side of the *Araucaria* screen. Then he highlights the statements that he selects as premises and conclusions. Then he clicks on the right side of the page and the system produces a numbered node corresponding to each statement. Arrows (directed lines) are drawn in representing the inferences from premises to conclusions. Thus the user can deploy *Araucaria* to produce an argument diagram that displays what he has analyzed as the sequence of argumentation in a text of discourse.

*Araucaria* has several other features that make it especially useful for analyzing and testing relevance judgments. It includes a set of presumptive argumentation schemes corresponding to those in (Walton, 1996). These argumentation schemes, like argument from consequences, for example, are especially useful for evaluating chains of argumentation built up from argument structures that are neither deductive nor inductive. New schemes can be added, and alternative scheme sets are being made available on the project website:

<http://www.computing.dundee.ac.uk/staff/creed/araucaria/>

Based on the user's markup of a given argument, *Araucaria* can help to locate "missing premises" required to complete the argument but not explicitly stated in the given text of discourse. *Araucaria* is currently being used for teaching and research in several universities and schools. It is also possible to log on to an *AraucariaDB* online repository containing examples of argumentation. You can search for particular forms of argument and you can contribute your own analyses to the database. This repository is being used to build up a large corpus of examples of marked-up cases of argumentation available online to the academic community. Currently, a dialogue markup language is being built onto *Araucaria* that will enable dialogue-generating software to be implemented as part of a comprehensive system of argumentation analysis.

*Araucaria* can not only help a user make up an argument diagram, but it can also be used to identify the particular argumentation scheme that is the warrant of an inference from a set of premises to a conclusion. In some cases, the argumentation scheme is very useful for identifying non-explicit premises in an argument. Thus, it would appear that *Araucaria* is potentially a most useful tool to help with making judgments of relevance.

## 10. COMPONENTS OF A THEORY OF RELEVANCE

Summing up the findings of this chapter, three components are needed in order to have a theory of relevance that could solve the problems posed in this and prior chapters. The first is that there needs to be an underlying logical notion of relevance. This cannot be modeled completely by formal relevance logics of the semantic type. It needs to be based on the notion of chaining an argument forward toward an end point or conclusion to be proved. The second component is that the theory needs to deal with the various fallacies of irrelevance, not by just declaring them fallacious but by dealing with them in depth. The third component is the conversational framework of relevance. This needs to be based on Gricean conversation theory but also developed beyond it. Different kinds of goal-directed conversations need to be identified, and special institutional factors, especially in legal and political argumentation, need to be taken into account. The two methods that should be used to determine logical relevance are the technique of argument extrapolation and the technique of argument diagramming. Both methods are pragmatic in nature, meaning that they are meant to be applied to a specific case—generally, a given example presented in a text of discourse containing an argument of some sort. The kind of task of judging relevance by combining these two methods fits into a technology called *heuristics*, that has already been widely used in computing.

Heuristics are methods for deciding which, among several alternative courses of action, are the most effective means of achieving a goal (Pearl, 1984, p. 3). An example given by Pearl (p. 3) is that of the chess grand master who decides what his best move would be in a game by examining various moves and considering which one appears stronger. The basic method used by Pearl to model heuristics is that of the graph. One point in the graph is seen as the goal state and another as the given or starting point where a decision between alternative paths of action is being made. Another example is the road map problem (p. 9). A motorist wants to find the shortest path between two cities marked on a road map. This is a fairly simple kind of heuristic problem. All the motorist has to do is to look at the various alternative possible routes and try to judge which is the shortest by the distances, as they appear to be represented on the map.

Heuristics are applicable to relevance judgments in argumentation in two ways. One way is that a dialogue can be seen as having a starting point and a goal state. As the dialogue proceeds from the starting point, any argument or move at a given point will be relevant if it is part of a path that proceeds to the goal point. The other way is that the chain of reasoning in a given sequence of argumentation can be chained forward. The argument is relevant if this chain leads to the end point that is the conclusion to be proved. Thus heuristics can be applied quite nicely to relevance judgments in argumentation. Indeed, Pearl (1984, p. 27) has shown that the tasks of logical reasoning and theorem proving can be automated using a device called an AND/OR graph. This type of graph has OR links that represent alternative approaches to handling a problem and AND links that connect a parent problem to subproblems of which it is composed (p. 22). Logical reasoning or theorem proving begins with a set of axioms and a set of inference rules that allow the deduction of new statements at each step. The new statement is added at each step until eventually the conclusion is derived (p. 27). Thus the axioms are the initial points in the chain of reasoning and the conclusion is the goal point. AND/OR graphs are very similar to argument diagrams. Indeed, both of them are graphs.

Of course, logical reasoning and theorem proving of the kind considered by Pearl uses deductive rules of inference. The question is whether the same kind of heuristic problem solving structure could be applicable to relevance judgments where the rules of inference are argumentation schemes that are neither deductive nor inductive. The answer is that it should be applicable just as well in such cases. The problem is similar. You are trying to get from some given or initial point in a chain of reasoning to some end point that is the goal or target. You need to examine the various alternative paths of action that can be taken to see if there is a path that leads by a process of reasoning from the starting point to the end point. If the process of theorem proving can be automated by using heuristic graphs, then so can the process of judging relevance in cases where argumentation schemes as well as deductive rules of

inference are used for reasoning. The graph model of the heuristic process is not inherently different in the two cases. The difference is that, in the case of judging relevance based on a natural language text of discourse, there are many more problems of judging what the given statements are that represent the starting point of the argumentation in the case. There may also be problems with identifying the ultimate conclusion to be proved and the rules of inference that are being used. In principle, however, it would seem that the heuristic for theorem proving and the method for judging relevance in argumentation have the same general structure when modeled as graphs, once the argument in the given case is marked up as a set of premises, a conclusion to be proved, and a set of inference rules.

Thus, heuristics are nicely applicable to solving problems of relevance in argumentation. The basic technique in its simplest form is that of modeling an argument as a graph that chains forward in a sequence from a given set of premises, by a chaining of steps of inference, to an ultimate conclusion to be proved. What makes judging relevance difficult in so many of the cases we have examined is the additional problem of getting from the given natural language discourse to some precise markup of the argument as a set of premises, conclusions, and inferences. In so many of the cases we have examined, there is a lot of missing text, or there are ambiguities or other problems that make putting the argumentation into some argument diagram format problematic. In many such cases, the argument can only be judged to be relevant or not under assumptions about what the proponent of the argument in the case is trying to say. Still, we have seen that even in many of these incomplete cases, making a conditional judgment of relevance that depends on such assumptions is quite useful to help with analyzing and evaluating the argumentation in the case.

The way the textbooks treat fallacies of relevance generally shows why no formal deductive logic of propositions or quantifiers could ever hope to model the concept of relevance in a useful way. Indeed, there are certain special features of the way fallacies of relevance are treated that suggest that logical relevance needs to be thought of in more than a merely semantic way. It needs to be seen in a way that relates to how an argument is used in a kind of dynamic conversation where two parties are reasoning together. A useful theory of relevance needs to be Gricean in the sense that in each case, the given argument is seen as a contribution to a dialogue. A dialogue is a goal-directed conversational exchange in which two participants are communicating with each other by making moves (typically, putting forward arguments directed to the other party). Yet the theory should also include the logical aspect, the chain of reasoning used to prove a conclusion based on inferences of the familiar type in logic. An argument is judged to be relevant if it can be chained forward so that the ultimate conclusion of the connected sequence of reasoning is the proposition that was supposed to be proved. The central thing that defines this proposition is the issue, the conflict of opinions to be resolved in a critical

discussion, or, more generally, the problem to be settled by the argumentation in the type of dialogue in question. This problem, or issue to be settled, defines the goal of the dialogue: the goal of the argumentation is for the participants to settle this problem or issue by using rational and relevant argumentation that bears on it. In a criminal case, for example, the issue is whether the defendant is “guilty” or “innocent,” as shown in chapter 1. How do we know what type of dialogue the participants were supposed to be engaged in? In some cases, we do not know, and so, relevance or irrelevance of an argument used in that case cannot be determined, except on a provisional basis (by making assumptions about what type of dialogue was supposedly involved). But in other cases, the evidence given in the text and context of discourse in the case provides a basis for such evaluations.

It has been made clear in chapter 4 that judgments of the relevance or irrelevance of an argument need to be seen as relative to a conversation of which the argument is supposed to be a part. This relativity of relevance to a dialogue poses a problem for many philosophical critics, who will see it as a kind of postmodernism that they find objectionable. It is also a practical problem because even if it can be proved in Gricean conversation theory that somebody’s argument is irrelevant, the arguer may still reply, “Well, it may be conversationally irrelevant, but it is relevant, in the real world, from my point of view.” This kind of objection to the theory is not purely theoretical. It highlights a problem in trying to judge relevance and irrelevance in cases that are of practical importance. If conversations are goal-directed, what types of conversations are there, and what are their goals? To be of practical use, Gricean conversation theory must be employed in a framework that can identify the goals and rules of different types of conversations.



*This page intentionally left blank*

## The Dialectical Nature of Relevance

Case 1.8, Wigmore's example of the rose transplantation argument, showed dramatically how judgments of relevance and irrelevance are determined by the type of conversation two parties are supposed to be engaged in. The same argument can be relevant as part of one type of dialogue or conversation, but irrelevant if taken to be part of another. What is shown by this case along with many other cases examined so far is that relevance is relative to a conversation, and there can be different types of conversations. An argument may be relevant in a critical discussion about rose transplantation, but then cease to be relevant as the conversation moves to a deliberation on what to choose for dinner from a restaurant menu. Another factor shown in chapter 1 is that relevance can also be partly determined by procedural rules of debate or evidence in politics and law that are specific to the needs of social institutions. To deal with relevance and irrelevance in these cases, there must be an underlying notion of conversational relevance that is common to everyday argumentation, but that applies as well to special contexts like legal argumentation.

The framework of relevance set out in chapter 5 is based on a dialectical point of view postulating that an argument should be evaluated in regard to how it has been used in different types of dialogue. A dialogue is a conventional goal-directed conversational framework in which an argument is meant to contribute to the goal of the conversation at some stage of its development. Thus, this framework is an extension of Grice's project of articulating conversational maxims of relevance, and of recent theories on how argumentation is used in a context of dialogue, like that of van Eemeren and Grootendorst (*Arg. Comm. Fall.*, 1992) and Walton (*New Dialectic*, 1998). So conceived, relevance is not purely a matter of the logical form of a single argument, isolated from its context in a wider text of discourse. Instead, it is a matter of the conversational context of how an argument was used for some purpose in a given case. The theory is also pragmatic in nature (as opposed to being purely semantical), in that it judges relevance in relation to how an argument has been used in a given case. Types of dialogue (conversation)<sup>1</sup> that can be used as normative models to evaluate arguments used in particular cases have been defined in Walton (*Inf. Log.*, 1989, pp. 9-18), Walton (*Prag. Theory*,

---

<sup>1</sup> The word *conversation* is used by Grice (see chapter 4), but the word *dialogue*, taken here to be equivalent, is somewhat preferable because it is a little more abstract, in keeping with the normative purpose of chapter 5.

1995, chapter 4), and Walton and Krabbe (1995, pp. 65-85). These types of dialogue are more fully described in Walton (*New Dialectic*, 1998). In this chapter, it is shown how relevance should be understood in the kind of argumentation properly used in each type of dialogue. The account of relevance in these normative models sets up the dialectical framework necessary to build a theory and methods that can be used to judge relevance in any given case. It is shown in chapter 5 how each type of conversation has its own distinctive kind of relevance.

## 1. RELEVANCE IN A PERSUASION DIALOGUE

In a persuasion dialogue, each party has the goal of creating an argument where the conclusion is the opposite of the thesis of the other party, and all the premises are commitments of the other party. An illustrative case is the dialogue on tipping presented in Walton (*Plaus. Arg.*, 1992, pp. 7-11). Helen has the thesis that tipping is a bad practice that should be eliminated. Bob has the thesis that tipping is a good practice that should be retained. The issue in the dialogue on tipping is this pair of opposed theses—one proposition is the opposite of the other, and each party is trying to prove her or his thesis from premises that are acceptable to the other side—premises, that is, that the other side will grant.

In a persuasion dialogue, various kinds of moves are allowed, including the asking of questions, the answering of these questions, and the putting forward of arguments (Walton and Krabbe, 1995). But there are four basic requirements for an argument that has been used successfully and appropriately by a proponent in a persuasion dialogue (Walton, *Dial. Rel*, 1999, p. 121):

- (R1) The respondent accepts the premises as commitments.
- (R2) Each inference in the chain of argument is structurally correct.
- (R3) The chain of argumentation must have the proponent's thesis as its (ultimate) conclusion.
- (R4) Arguments meeting (R1), (R2), (R3) and (R4) are the only means that count as fulfilling the proponent's goal in the dialogue.

As we will see in chapter 7, requirements (R2) and (R3) are the normative basis of fallacies of dialectical relevance in a persuasion dialogue.

According to Hermagoras, relevance in a persuasion dialogue is determined by the issue. Something is relevant in the dialogue if it is related to the issue. A question would be relevant, for example, in the dialogue on tipping, if it is related to the issue of the dialogue—whether tipping is a good practice that should be continued. For example, the question, "Don't you think that tipping has bad consequences for the economy?" would be relevant, on the assumption (additional premise) that if a practice has bad consequences for the

economy, then (other things being equal) it is a bad practice that ought to be discontinued.<sup>2</sup> The question is relevant because it is related to Bob's thesis in the dialogue by a conditional that presumably both parties in the dialogue would generally accept.

However, our main concern is with arguments and the parts of arguments. How are they relevant in a persuasion dialogue? Arguments are used by one party in such a dialogue to prove a proposition (the party's thesis, or something needed to prove this thesis) by inferring it from premises that are commitments of the other party. Both sides use arguments in this same way in a dialogue like the tipping dialogue, where both parties have a burden of proof. However, there can also be instances of persuasion dialogue where one party has the burden of proof, and the goal of the other is merely to ask critical questions that throw enough doubt on the other party's thesis that his burden of proof is not fulfilled.

One proposition in a persuasion dialogue is *probatively relevant* to another proposition if it can be used as an argument to give positive support (pro-argumentation) for that other proposition or if it can be used to cast doubt on this other proposition. Propositions can be topically relevant in a persuasion dialogue without being probatively relevant. For example, 'Tipping leads to loss of self-esteem' and 'Napoleon never went on record as being for or against tipping' are not probatively relevant to each other (as far as we know), but each is topically relevant to the other. Probative relevance in a persuasion dialogue is determined by how an argument is being used in the context of a dialogue—at a particular argument move in a given stage of the argument—in relation to how the argument has gone along in the dialogue up to that particular move. An argument is rightly evaluated as probatively relevant at a particular point in a persuasion dialogue if it has a probative use in persuading the respondent to go ahead and commit to a proposition that the proponent of the argument can use to prove her thesis in the dialogue (or cast doubt on the respondent's thesis). The parts of an argument or the whole argument can be probatively relevant in this sense.

Blair (1992, p. 205) utilizes this general notion of probative relevance when he defines the concept of premissary relevance, stressing the use of a proposition that is a commitment of the respondent as part of an argument used to rationally convince the respondent to accept a conclusion. According to Blair (1992, p. 205), a proposition *P* has *premissary relevance* to a conclusion *C* where a proponent presents a "well-ordered argument" to a respondent for *C*, based on a constellation of propositions including *P* such that this constellation lends support to the acceptability of *C*. In Blair's account of premissary

---

<sup>2</sup> There could also be elements of deliberation involved in this case, insofar as Bob or Helen may be re-evaluating their own practices on tipping, or talking about policies that may apply to their own conduct, or to that of groups they belong to.

relevance, the proponent brings forward this constellation of propositions in order to convince the respondent of the acceptability of *C*.

To judge whether an argument is relevant in a persuasion dialogue in a given case, a critic has to look not only at the issue of the dialogue, but also at what stage the dialogue is in, what the previous move (or recent sequence of moves) was, and what implicit (unstated) premises or inference steps may be involved. As emphasized by Grice (1975) in his analysis of conversational implicature, an analyst must also make presumptions about what the hearer is likely to know and what the speaker is likely to know the hearer will know.<sup>3</sup> As Dascal (1977, p. 323) has emphasized, heuristics, or “educated guessing, 6” is an important part of judging relevance. One special subtype of persuasion dialogue is the critical discussion, where the goal is to resolve a conflict of opinions by rational argumentation (van Eemeren and Grootendorst, 1984; 1987). According to van Eemeren and Grootendorst (1984, p. 34), the purpose of the critical discussion is to resolve a conflict of opinions by means of rational arguments. A successful critical discussion, according to van Eemeren and Grootendorst (1984, p. 86) ends with a resolution of the conflict. Otherwise it is “not clear whether the discussion has had any point”. But in a persuasion dialogue that is not a critical discussion, the dialogue may be regarded as successful if the discussion has thrown light on the issue by revealing new commitments through strong and persuasive arguments, even if the conflict of opinions was not resolved.

The issue, or conflict of opinions to be resolved, has two sides, and each side, called a *point of view (standpoint)*, is made up of two components (van Eemeren and Grootendorst, 1984, p. 79): a proposition or expressed opinion, and a positive, negative, or neutral attitude towards that proposition. There are two basic subtypes of critical discussion. In the *simple critical discussion* (1984, p. 85), one party defends a particular proposition known as her *thesis*, and the other party raises critical questions to cast doubt on that thesis. In the *complex critical discussion* (p. 90), each participant has a thesis, and each is obliged to defend that thesis. Thus in a critical discussion, each party has a positive attitude toward her own thesis and a negative attitude toward the thesis of the other side. In the complex critical discussion, each party has a burden of proof. But in the simple critical discussion, the one party has a burden of proof, whereas the other party can successfully resolve the conflict of opinions by raising questions that throw enough doubt on the arguments of the first side to prevent them from fulfilling the burden of proof for that side.

According to van Eemeren and Grootendorst (1984, pp. 85-86), there are four stages of a critical discussion. At the confrontation stage (p. 85), a dispute arises where one party advances a point of view and another party casts doubt on that point of view or advances an opposed one. At the opening stage of the

---

<sup>3</sup> See chapter 4, section 7 on Gricean implicature.

discussion, the two parties agree to attempt to resolve the dispute by taking sides and undertaking to challenge the other side by advancing rational arguments. Each assumes the role of a proponent or respondent (called the *antagonist* by van Eemeren and Grootendorst, 1984, p. 86, and often called the “opponent”).

During the argumentation stage, each side brings forward arguments to support its own point of view, and each takes turns questioning and criticizing the arguments put forward by the other side. So called *pro-argumentation* is used to support one’s own point of view, and *contra-argumentation* is used to criticize or refute the other party’s point of view. There are ten rules for the argumentation stage that govern the kinds of moves made on both sides (van Eemeren and Grootendorst, 1987, pp. 284-286):

- Rule 1:** Parties must not prevent each other from advancing or casting doubt on standpoints (p. 284).
- Rule 2:** Whoever advances a standpoint is obliged to defend it if asked to do so (p. 285).
- Rule 3:** An attack on a standpoint must relate to the standpoint that has really been advanced by the protagonist (p. 286).
- Rule 4:** A standpoint may be defended only by advancing argumentation relating to that standpoint (p. 286).
- Rule 5:** A person can be held to the premises he leaves implicit (p. 287).
- Rule 6:** A standpoint must be regarded as conclusively defended if the defence takes place by means of the common starting point (p. 288).
- Rule 7:** A standpoint must be regarded as conclusively defended if the defence takes place by means of arguments in which a commonly accepted scheme of argumentation is correctly applied (p. 289).
- Rule 8:** The arguments used in a discursive text must be valid or capable of being validated by the explicitization of one or more unexpressed premises (p. 290).
- Rule 9:** A failed defence must result in the protagonist withdrawing his standpoint and a successful defence must result in the antagonist withdrawing his doubt about the standpoint (p. 291).
- Rule 10:** Formulations must be neither puzzlingly vague nor confusingly ambiguous and must be interpreted as accurately as possible.

Violations of rules, according to van Eemeren and Grootendorst’s theory, correspond to various traditional informal fallacies.<sup>4</sup> For example, violating Rule 3 corresponds to the straw man fallacy. Violating Rule 4 would correspond to fallacies of irrelevance.

---

<sup>4</sup> See especially van Eemeren and Grootendorst (1987), where an account is given of which fallacies are violations of which rules.

At the concluding stage of the critical discussion (van Eemeren and Grootendorst, 1984, p. 86), the question is answered whether the dispute has been resolved.

Naturally, not every discussion will automatically lead to the resolving of the dispute, and it sometimes happens that when the discussion is over the protagonist still takes the same attitude and the antagonist still has his doubts, without either of them being open to an accusation of irrationality. Be that as it may, a discussion is never complete unless the discussants have collectively established its outcome. If this is not done, it is unclear whether the discussion has had any point.

Although the conclusion of a discussion does not have to be final, according to van Eemeren and Grootendorst (p. 86), it is clear that a successful discussion ends with the resolution of the dispute, showing that the point of view of the one side is established and that of the other side is refuted.

The critical discussion clearly is a framework in which an argument can be judged to be relevant or not, in relation to its use in a stage of that framework in a given case. The issue of the critical discussion, broadly speaking, defines what is relevant or not. Yet, an argument put forward or a move made may be relevant if placed at one stage even if it would be irrelevant if placed at another stage. Thus, the stage of the argument will also be a factor. Hence, according to van Eemeren and Grootendorst (1992, p. 142), the kind of relevance needed for the critical and normative evaluation of arguments is pragmatic in nature: one element of discourse is relevant to another to the extent that both elements are functional in relation to the purpose of the discourse. According to their account (1992, p. 156), a move made in argument has positive evaluative relevance if it contributes to resolving the difference of opinion in a critical discussion; otherwise, it does not.

It is clear from the rules for the critical discussion that, as well as meeting requirements (R1), (R2), (R3) and (R4), the argumentation used in such a discussion involves several additional requirements. In other words, the critical discussion is best seen as a special subtype of persuasion dialogue, which has requirements additional to those of persuasion dialogue generally.<sup>5</sup> In order to be a persuasion dialogue, a conversation must be a dialogue with two participants, each of whom must prove her/his thesis using only arguments that conform to (R1) through (R4). But in order to be a critical discussion, all the other requirements set in place by the ten rules cited must be met.

---

<sup>5</sup> There are discrepancies in the various classifications of types of dialogue previously given in the literature. In the account given in Walton and Krabbe (1995), the critical discussion is said to be equivalent to the persuasion dialogue. However, in Walton (*Prag. Theory*, 1995, p. 100), which was actually written somewhat later, the critical discussion is classified as a subspecies of persuasion dialogue.

## 2. RELEVANCE IN INFORMATION-SEEKING DIALOGUE

Information-seeking dialogue is important in AI because many computer programs have the purpose of passing some kind of information from a source to a user. According to Carberry (1990, p. 3), an *information-seeking dialogue* contains two participants, one seeking information and the other attempting to provide the information". The goal of information-seeking dialogue is the transfer of information from one party to another. However, normally it is not just any information sought randomly. The questioner is seeking information on some particular subject, or she wants it to carry out a particular task. Therefore, the role of the respondent is to try to supply the information needed for this purpose. The roles of the two parties are asymmetrical.

Generally, the method of the questioner is to ask questions, while the respondent tries to give as direct answers to these questions as possible (Hintikka, 1981). However, it can be legitimate for the respondent to reply "I don't know" in some cases, or even to reply to a question with another question, like "What do you mean by 'normal'?" If a question is problematic for the respondent to answer directly, because it is complex or contains presuppositions that the respondent is not committed to, the appropriate response is for him to challenge the question. An example of the kind commonly found in logic textbooks is the following:

*Case 5.1:* When did you stop engaging in child and spouse abuse in your hidden activities?

Depending on what has transpired in the prior sequence of dialogue, and depending on the respondent's commitments, his best course may be to challenge the presuppositions, one at a time, in this complex question.

Sperber and Wilson (1986) define relevance in terms of the collection of information (p. 47). What is relevant is the particular piece of information that has the most "contextual effects" among all the pieces of information that become known to an individual, meaning that more inferences are drawn about this particular piece of information than about the others. They give the example (pp. 48-49) of someone who is approaching another person seated on a park bench. She thinks the person approaching is a "dreadful bore." Given her discomfort at his appearance, she will focus on his approach. That becomes the most relevant piece of information in her perceptual environment. Other facts she is aware of, like the presence of a tree or other people are less relevant, and she draws no inferences based on them.

Berg (1991, p. 419) sees the Sperber and Wilson conception of relevance as defined in a conversational context where the goal for the participants is the collection and processing of information. At any rate, it seems fair to say that



the Sperber and Wilson conception of relevance fits somewhere into a context of dialogue where information-seeking of some kind is the goal.

One familiar kind of example of information-seeking dialogue is the televised interview of a celebrity, where the interviewer tries to get him or her to reveal personal facts or views that will be of interest to the audience. Another very familiar kind of example is the case where a stranger in a city asks a passerby, "Can you tell me where Spence Street is?" This indirect question is a request for information. The questioner really wants to know how he can get from his present location to Spence Street by the most convenient route available. Note that this example is not a case of expert consultation dialogue because the respondent does not have to be a cartographer, or any other kind of expert, to give an informative and helpful answer. The questioner does presume, however, that the respondent is, or may be, in a position to know the answer, that is, that the respondent is a person who is familiar with the streets in that area.

Irrelevance is most noticeable in information-seeking dialogue in cases where a reply is given that does not really function as an adequate response to that specific question but is really an answer to a different question. Once you start to notice this phenomenon, you see how common it is, for example, in televised celebrity interviews. The reply does give some information that may be broadly relevant in context, but it is not the information specifically asked for by the question. Many cases of this type are evaluated in Walton (*Quest.-Reply*, 1989).

This type of irrelevance is sometimes seen in political interviews where a question is posed with the aim of asking for a specific item of information that the respondent is presumed to possess. The following example, constructed for purposes of illustration, will indicate the typical format of this kind of question-reply sequence.

**Case 5.2:** **Interviewer:** We have heard that your party's new economic policy will lead to the loss of fifty thousand jobs, according to a statistical projection made available to you. What was the outcome predicted by this statistical projection?

**Politician:** You have to look at our policy in perspective. Its goal is to increase the number of jobs long-term by decreasing the deficit.

The propositions in the respondent's reply may be true, but they are not relevant to the question. A relevant reply would be either an answer supplying the requested information or the giving of a reason why the respondent would not, or could not, give out that information.

Another important kind of case of information-seeking dialogue appears in searching for information in electronic environments. For example, in doing

research on a topic, a common preliminary stage is the collection of relevant data by doing a computerized search of a database. In this type of information-seeking, one party in the dialogue is the information-seeker, the user of the computer system. The other party is the computer system itself—a software package that is set up to answer queries and provide information. Marchionini (1995) breaks this information-seeking process down into several components (pp. 51-57): the recognition of an information problem, the defining of the problem, the formulation of a query, the execution of a search, the examination of the results, and the extraction of information.

Schamber, Eisenberg, and Nilan (1990) have defined relevance as a key concept in the design and evaluation of information retrieval systems. According to their definition, relevance is a “dynamic human judgment process” (p. 755), but it is a “systematic and measurable phenomenon” (p. 755). According to their definition (p. 774) relevance in an information-seeking retrieval system is “a multidimensional cognitive concept whose meaning is largely dependent on users’ perception of information and their own information need situations”. What is stressed here is that what is relevant in an information-seeking environment depends on what the user wants or needs to know and on how the user defines the initial problem that leads to the formulation of the queries to be put forward in the searching process. This notion of relevance is distinctively different from that of the persuasion dialogue.

Relevance is important in systems of computer software designed to help a user search through a database for information. Some would say that the kind of reasoning used in such a question-reply searching process is not really “argument.” However, it is classified as argumentation in the dialectical sense, because it is a use of reasoning for some purpose, that is, to solve a problem or answer a question by searching out relevant information. Relevance is a very important concept in this type of argumentation, but it needs to be viewed in a different way from relevance in the persuasion type of dialogue. According to Chamber and Eisenberg (1991, p. 238) relevance is the central concept in the field of information systems technology, of the kind used by library and information scientists. They state that “for half a century we have used this concept [relevance], explicitly or implicitly, in system design and evaluation” (p. 238). In such a system, Chamber and Eisenberg see relevance as a relationship “between a user and some information retrieved” (p. 238). This definition fits very well into the dialectical theory of relevance in information-seeking dialogue, where a questioner is seeking information on some particular subject. The role of the respondent in the dialogue (the software package in the information system) is to supply the information needed for this purpose.

According to Chamber (1994, p. 5), in the typical model of this information-seeking process, “the user perceives the problem and makes a request, interacting with an intermediary or directly with the system.” The user or intermediary then puts a “formal search query” into the system and “receives

and evaluates system output” (p. 5). He then pursues the items received that “seem likely to contain information to solve the problem.” Schamber (1994, p. 5) gives the pictorial representation in figure 5.1 to illustrate the stages in this sequential process. In this framework, relevance is seen as *cognitive*, depending on human knowledge and perceptions, and as *situational*, relating to an individual user’s problem (Schamber, 1994, p. 6). So conceived, the cognitive and situational notion of relevance important for information systems fits the dialectical model of relevance in information-seeking dialogue. Relevance of argumentation in a given case is set by the initial problem or query of the user and is then evaluated in the dialogue sequences of queries and replies that constitutes the profile of dialogue for the given case. The best method for determining relevance is the profile reconstruction method. But at the initial stages of a search, the method of argument extrapolation can also be used.

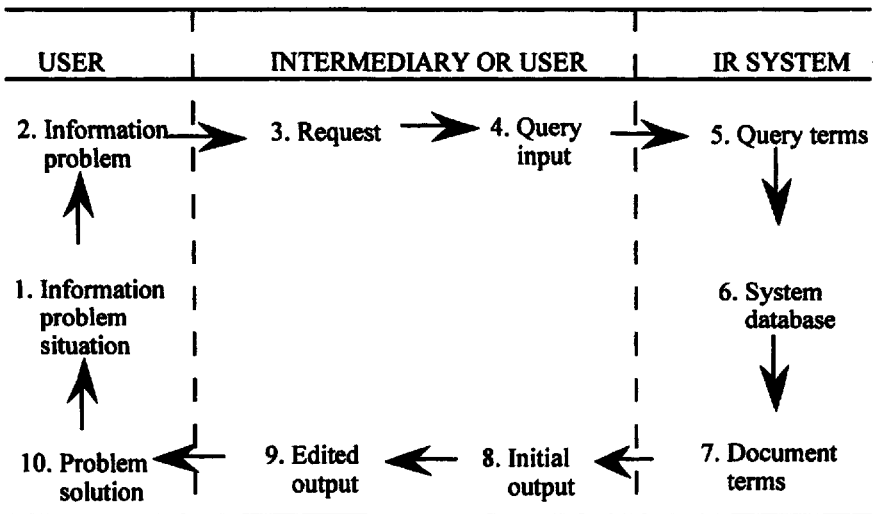

**Figure 5.1:** Information Retrieval Interaction Model <sup>6</sup>

One very important aspect of searching a database for the purpose of information retrieval is the choice of key words that can be used to aid in the formulation of a search query and that will make the search more productive. By the use of key words, the items in a query, expressed in key words, can be

<sup>6</sup> This figure is redrawn from Schamber, 1994, p. 5.

matched up with items in a database that have titles or abstracts containing these same key words.

What is particularly useful here for modeling the reasoning used in an information retrieval system is the systems of relatedness logic and information — like the containment logic cited in chapter 4, section 3. These formal systems of logic, developed most fully in Epstein (1994; 1995), can be used in the inference system for forward chaining of an argument, instead of the usual formal systems of deductive logic. As shown in chapter 6, the usual, classical systems of deductive logic do not model relevance, and in fact, they admit of all kinds of paradoxical inferences that clearly reveal their failure to model relevance. The relatedness systems developed by Epstein, as noted in chapter 4, exhibit the same paradoxes, in modified form. This suggests that these systems (by themselves) do not have the kind of relevance needed for the purpose of evaluating criticisms of relevance and irrelevance in argumentation, or for the purpose of studying fallacies of relevance. However, when integrated into the new dialectical theory of relevance, these systems can be used to provide the inference linkages needed for forward chaining of argumentation—the essential tool needed to make the method of argument extrapolation work in the dialectical theory.

This use of relatedness logic works by taking the key words in a query to represent the subject-matters of a proposition. Then relevance can be defined on a given set of propositions containing key words using the criteria of subject-matter overlap and information containment supplied in the logical systems developed in Epstein (1994; 1995). There is no space here to go into all the details of how this research project for modeling relevance in information retrieval using relatedness and information containment logics should work. Suffice it to say that relatedness logic is useful here precisely because it is sensitive to the sharing of common subject-matters by pairs of propositions (represented by key words) in a way that classical deductive logic is not. So a relatedness logic can cut down the amount of searching needed to find items that are relevant to a given query or problem, by homing in only on those items that share key words with the query. By this means, the semantic systems of relevance logic can be combined with the dialectical frameworks of argumentation used to provide a globally integrated logical system of relevance evaluation.

### 3. OTHER TYPES OF DIALOGUE

Persuasion dialogue and information-seeking dialogue are clearly not the only recognizable types of dialogue in which argumentation occurs in everyday conversations. For example, an argument can occur in a negotiation, and negotiation is a different type of dialogue from critical discussion, because of its

different goal and the different kinds of arguments appropriately used to realize that goal. In Walton (*New Dialectic*, 1998), six basic types of dialogue are explained.

Each of them is described in Walton (*New Dialectic*, 1998) as starting from an issue with two sides, and as having a confrontation, opening, argumentation, and closing stage. The chief defining characteristic of persuasion dialogue given is the goal of each participant. Each, to fulfill her obligation, must prove her thesis from premises that are all propositions the other participant is committed to. Persuasion dialogue is taken in Walton and Krabbe to be equivalent to the critical discussion type described by van Eemeren and Grootendorst, although it is defined in a somewhat different way. In Walton and Krabbe (1995, p. 71) persuasion dialogue is described as a dialectical structure of the kind defined by Hamblin (1970; 1971), where both participants have a log or repository of every proposition that participant has become committed to during the course of the dialogue at the various moves. A *move* (Walton and Krabbe, 1995) is a sequence of locutions advanced by a participant at a particular point in the sequence of dialogue (p. 71). Four kinds of rules define not only persuasion dialogue, but all the other basic types of dialogues as well. *Locution rules* (Walton and Krabbe, 1995, p. 72) define the locutions permitted (like questions, replies, arguments, etc.) used at each move. *Commitment rules* (p. 72) define the insertion and deletion of propositions from a participant's commitment store. *Structural rules* (p. 72) define the order in which the moves may be made. *Win-loss rules* (p. 72) determine the conditions under which a participant successfully fulfills her goal, thereby "winning the game." As Chris Reed pointed out, a dialogue can thus be seen as having a starting point of the initial commitments, a series of transformations of commitments into new commitments based on the four kinds of rules, and an end point that is the commitment to be proved by the sequence of argumentation. It fits nicely into the familiar structure of a search process of the kind familiar in AI.<sup>7</sup>

The account of the six basic types of dialogue given in Walton and Krabbe (1995) and Walton (*New Dialectic*, 1998) is not meant to imply that all conversational frameworks of argumentation can be reduced to these six types. However, many of the conventional types of conversational contexts of argument we become familiar with in using everyday arguments can either be shown to be subtypes of one of these basic types, or to be mixed dialogues that are compounds of two or more basic types. What follows next is a brief description of the structure of each of the four remaining types of dialogue, together with a brief explanation of what relevance is in each type.

---

<sup>7</sup> If memory serves, the first time I heard this interesting remark was at the Bonskeid House Conference cited in the Acknowledgements.

<b>Type of Dialogue</b>	<b>Initial Situation</b>	<b>Participant's Goal</b>	<b>Goal of Dialogue</b>
Persuasion	Conflict of Opinions	Prove Your Thesis Is True	Resolve or Clarify Issue
Inquiry	Need to Have Proof	Find and Verify Evidence	Prove (Disprove) Hypothesis
Negotiation	Conflict of Interests	Get What You Most Want	Reasonable Settlement That Both Can Live With
Information-Seeking	Need Information	Acquired or Give Information	Exchange Information
Deliberation	Dilemma or Practical Choice	Co-Ordinate Goals And Actions	Decide Best Available Course Of Action
Eristic	Personal Conflict	Verbally Hit Out At Opponent	Reveal Deeper Basis of Conflict

**Table 5.1** Six Basic Types of Dialogue

The goal of negotiation dialogue is to “make a deal”—to reach an agreement on how to divide up certain goods or interests at issue—that both parties can live with. The goal for a participant is to make trade-offs or concessions such that you get what is most important to you while leaving the other party enough of what is most important to him that he is satisfied. Thus, one’s aim in a negotiation should not be to defeat the other party totally and take all the goods or interests at issue oneself, leaving nothing of value to the other party. This kind of outcome is bound to have future repercussions. The goal should be to reach an agreement that is relatively acceptable to both parties, even if not ideal or maximal for all parties.

Different subtypes of negotiation dialogue are recognized by Walton and McKersie (1965, pp. 4-6), including some types, like distributive bargaining (p.

4) that are about dividing up goods or services and where one party's gain is the other's loss. In another type, called attitudinal structuring (p. 5), the issue is not purely economic, but involves relationships like friendship or respect, and the argumentation relates to personalities and motivations.

Commitment in negotiation dialogue is defined by the *interest*, that is the underlying goal or objective of a participant. According to Fisher and Ury (1991, p. 47) each side in a negotiation has multiple interests, and an important task of the dialogue is defining both your own interests and those of the other party. The methods they suggest include the asking of questions of the other party and the use of empathy, or "putting yourself in the shoes of the other person" (p. 44).<sup>8</sup> By clarifying interests in a negotiation dialogue, both participants should move toward commitment gradually, Fisher and Ury declare (p. 172). Walton and McKersie (1965, p. 60) see commitment in negotiation dialogue as a kind of pledge to a course of action. The communication of commitments takes the form of offers, threats, and promises made to the other party. Donohue (1981, p. 112) makes it clear that threats are a normal part of negotiation dialogue. Although threats can be high-risk tactics that are difficult to retract or back down from, it is clear that they are a normal and acceptable kind of argumentation in negotiations of all kinds. For example, in a union-management negotiation on a wage settlement issue, it is normal for the union side to threaten strikes or work slowdowns, and it is normal for the management side to threaten layoffs, bankruptcy, or other actions that represent a loss for the union side.

As with other types of dialogue, relevance in a negotiation dialogue depends on the issue and on the stage the dialogue is in. Ideally, an agenda is set in the confrontation stage, where the issue or issues to be resolved are clearly stated. In a negotiation, there can even be subnegotiations about the order these issues should have on the agenda. It is important for a successful negotiation that issues be clearly stated and prioritized in a way that is satisfactory to both sides. Otherwise, it becomes problematic to determine whether an argument that arises at a later stage really is relevant or not. A hotly disputed but irrelevant issue can be a digression that distracts everyone, leading to failure of the negotiation to reach a successful conclusion. As Gulliver (1979, p. 126) shows, as a negotiation proceeds, new details may enter in, as dormant issues come to be part of the discussion, and hence new complaints and demands can swell the original agenda, creating digressive lines of argument that may have the effect of preventing any useful discussion of the original issues.

Jacobs and Jackson (1992, p. 63) have shown, using case studies of child custody disputes directed by a mediator, how such digressions—particularly highly emotional counterblaming arguments in the form of *ad hominem* attacks

---

<sup>8</sup> Empathy is also especially important in persuasion dialogue, as the account of this type of dialogue (above) indicates.

on the other party—can make the participants lose track of the original issue of arriving at mutually agreeable custody or visitation arrangements. Insults, threats, and *ad hominem* attacks are stimulating to the participants, giving them an emotional release, but also create digressions that are significant obstacles to the progress of the negotiation dialogue towards a successful outcome.

In these cases, there can be a contextual shift from a negotiation to a persuasion dialogue on the subject of who is to blame for the divorce, or even a shift to an eristic dialogue (quarrel) expressing heated recriminations on both sides.

#### 4. ERISTIC DIALOGUE

A framework of dialogue not often associated with logic is *eristic dialogue*, an adversarial verbal exchange of arguments in which each party attacks the other party personally. The most familiar type of eristic dialogue is the *quarrel*, where both parties are emotionally upset and one tries to hit out at the other, blaming him or her for some character faults. The quarrel is no friend of logic, and as the saying goes, it generates more heat than light.

However, it can have benefits of a sort. The real purpose of the quarrel is to bring grievances to the surface that have been part of a relationship for some time but have been unexpressed. In polite conversation or in daily business activities, for example, it would be inappropriate to bring up such matters. And in fact, it is the overlooking of these matters, often based on small differences that can be ignored temporarily in order to make collaboration possible, that allows other kinds of dialogues to go ahead smoothly.

The quarrel typically comes on suddenly, like a thunderstorm. Suddenly both parties become very emotional and interrupt what they are doing. One blames the other for some perceived fault, and the other replies by counterblaming, for example, saying, “You’re just as bad!” What is characteristic of the quarrel is the lack of relevance in the sequence of argumentation. The issue that prompted the quarrel may be unrelated to the respondent’s counterargument. For example, it may have been the charge that one party didn’t do the dishes. But from there, the quarrel may leap to an incident two years earlier, where one party was inconsiderate in public, making the other feel like a fool in front of all his friends. The quarrel tends to skip rapidly from one topic to another. The only glue that holds it together as a sequence of argumentation is the continual hitting out at and blaming the other party.

The quarrel is frequently perceived as a highly negative type of dialogue, from a logical point of view, and in fact it can be connected with fallacies and logical difficulties. The problem is that the quarrel tends to be an interruption. A critical discussion or a deliberation may have been taking place, for example, that was progressing nicely. But if it degenerates into a quarrel, this shift might



block the possibility that the prior dialogue will resume and come to a successful closure.

Even so, the quarrel, by itself, can be a beneficial type of dialogue exchange. If both participants succeed in articulating hidden grievances that they are very sensitive about, but have been unable to express before, then the other party can come to a new realization of this problem in their relationship and take it into account in further dealings with that person. The quarrel can then be positive or beneficial to the extent that these hidden grudges are brought to the surface and are acknowledged by the other party. This kind of exchange can help to bond people together in a personal relationship and make the relationship function more smoothly. In a good quarrel, at the closing stage, the participants “make up,” and agree to be more sensitive to the newly expressed concerns of the other party in the future.

The eristic framework of dialogue was recognized by the ancients as a context of argument that can be a danger to good reasoning. Both Plato and Aristotle saw eristic dialogue as a negative counterpart to dialectic, a kind of dark counterpart or “antilogic” to successful dialectical argument that throws light on a subject in a reasoned discussion.

Case 4.4 illustrates how the *ad hominem* argument, if continued over a sequence of moves in a dialogue, can indicate the presence of a quarrel. In the poisoning the well variant of the *ad hominem*, each party uses the *ad hominem* attack to suggest that the other party is inescapably biased. This sequence of *ad hominem* exchanges has the effect of closing off avenues of critical discussion because neither party can trust the other to obey the Gricean conversational maxims. The danger in such a case is that if the dialogue began as a critical discussion, the intervening quarrel may be irrelevant to the critical discussion even though it is colorful and stimulating. The quarrelsome exchange may even block any avenue of real critical discussion.

It should be added, however, that the observation that the quarrel exhibits a high degree of irrelevance needs to be examined more carefully, and to be qualified and clarified. It is true that the quarrel skips from one topic to another in an apparently random manner. However, this apparent randomness may conceal a connectedness and coherence that is intrinsic to the eristic dialogue. When a quarrel skips from one expressed grievance to another, it seems that the topic of the one grievance is irrelevant to the topic of the other.

For example, one complaint may be about not taking out the garbage, but the next may be that the person who made the complaint about the garbage was inconsiderate at a party last week. It looks like there has been a skip from one topic, the garbage, to another unrelated topic, the behavior at the party. But it may be that this transition from the one complaint to the other only appears to be an irrelevant step because we are looking at the quarrel from a point of view of our expectations about the kind of argumentation that should take place in a critical discussion or a persuasion dialogue. From this viewpoint, such a leap

would be irrelevant. But in a sense of interpersonal relevance appropriate for the quarrel as a type of dialogue, the transition was relevant. It was relevant because both complaints, and the transition from one to the other which the first one gave rise to, contribute to the goal of this eristic type of dialogue. Precisely what is needed to fulfill the goal of eristic dialogue is the expression of the complaints and hidden grievances that both sides feel so deeply about but have been unable to express in a more polite type of conversational exchange.

The kind of relevance found in a quarrel is intrinsically different from that found in a critical discussion or persuasion type of dialogue. The kind of dialectical relevance appropriate in the quarrel as a type of dialogue is *interpersonal relevance*, meaning that what establishes one argument or move as dialectically relevant in relation to a prior argument or move is its importance to the speaker - a deep personal grievance or complaint that is as important to her as those expressed in the prior move of the other participant in the dialogue. Relevance of this kind is a deeply personal matter of feelings concerning what is important to a person. The kind of dialectical relevance found in the critical discussion could be described as more logical in nature, having to do with the use of argumentation to prove a point, or proposition at issue.

## 5. DELIBERATION AND INQUIRY

Deliberation as a framework of argumentation is typified by a town hall meeting, where a group of citizens gather to discuss some practical question, for example, whether to go ahead and buy a new sewer system or make do with the old one. The purpose of a deliberation is to discuss the alternatives available in a particular set of circumstances where action of some sort seems to be required, in order to judge which is the best or most prudent course of action to take. The various stages of the deliberation dialogue have been represented in a formal model by Hitchcock, McBurney, and Parsons (2001). At the opening stage, an issue or "governing question" posing a problem about what should be done is asked. The subsequent discussion stage in which this question is addressed includes the consideration of various proposals for possible courses of action. At an argumentation stage, arguments for and against the various proposals are discussed. Finally, there is a closing stage where the participants, after examining all the relevant arguments on both sides, come to agreement on some course of action as the best way to solve the problem.

Deliberation is not always with a partner who is another person. Even argumentation in a solitary deliberation can be evaluated as an instance of a kind of dialogue exchange of viewpoints where the one person takes turns looking at the pros and cons of two opposed possible courses of action. Sometimes such solitary deliberation takes the form of a "devil's advocate" argument, where an individual tries to imagine how a spokesman for the opposed view would argue.

The main thread of reasoning that holds a deliberation together is called *practical reasoning*, a species of goal-directed reasoning where an agent reasons toward a conclusion that represents a course of action as prudent, based on premises describing goals and the particular circumstances of the agent's situation as known to the agent (Walton, *Pract. Reas.*, 1990, p. 1). Practical reasoning was familiar to the ancients, and in particular to Aristotle, who used the term *phronesis* (practical wisdom) to describe it. In the simplest kind of case, a practical inference has two premises and a conclusion of the following form:

- (PI) My (the agent's) goal is to realize *G*.  
 A way to bring about *G* is to carry out action *A*.  
 Therefore, I must carry out action *A*.

However, (PI) is clearly a simplistic representation of how practical reasoning works in a realistic kind of case. Several complications arise.

It may be that carrying out *A* has negative consequences, that is, consequences that would go against *G*, or some other goal I might also have. Also, I may have other goals in addition to *G*. These could conflict with *G*, and if they are more important to me, perhaps I need to rethink whether I really want to realize *G* in this situation.

Another complication is that I may not be able to realize *G* directly, by simply carrying out one action, *A*. Other preliminary actions may also be required.

*Case 5.3:* My goal is to get to Leiden before noon. I come to the conclusion that the best way to do so is to catch the 10:25 from Amsterdam Central Station. But in order to do that, many subactions are required. I have to take the tram to the Central Station. But in order to do that, I have to get a tram ticket. And in order to do that, I have to go to the tobacco store on the corner. But in order to do that, I have to open my office door.

One can see that in this very ordinary kind of case, there will be a long series of subactions needed to carry out my goal. One could try to formulate and list the whole series of such subactions. If this were done—as many cases in Walton (*Pract. Reas.*, 1990) illustrate—the result would be a long chain of connected practical inferences of the form (PI) forming a sequence of practical reasoning. The conclusion of one subinference becomes a premise in a next sub-inference in the sequence.

In the field of AI called planning, the aim is to build automated systems in which an agent works toward carrying out a goal by means-end (practical) reasoning. The purpose of this kind of dialogue is not just to seek information,

although information is generally required in planning. The purpose is the practical one of finding the means, in a given situation, to carry out a goal. The problem is not just one of finding or communicating information, but of solving a practical problem by determining the best course of action in the given situation. Thus, deliberation is different from information-seeking dialogue even though both types of dialogue are very important in AI. The theory of planning in AI is based on the framework of an agent who has a goal and who assesses a situation for a sequence of actions that could lead the realization of this goal (Wilensky, 1983, p. 5). So conceived, planning is a kind of problem-solving. It can be applied to typical cases of robotics in which a robot is programmed to carry out a goal. For example, in the blocks problem, there is a set of numbered blocks on a table, and the robot has the goal of putting them in a stack with the numbers in a certain order. Early planning systems attempted to use formal deductive strategies, but ran into a problem. The so-called frame problem (Carberry, 1990, p. 23) is that on carrying out each step in a plan, one must formulate not only all the changes in the world at that point, but also all the factors that remain unchanged. To deal with this problem, the so-called STRIPS system (Fikes and Nilsson, 1971) took a state-space approach to planning by breaking a plan to solve a problem into three stages. There is an initial state of the world, an ultimate goal state to be achieved, and a set of operators that transform one state into another. The frame problem was dealt with by assuming that all the existing factors not affected by the transformation of one state into another remain unaffected. STRIPS was based on a means-end analysis of reasoning comparable to practical reasoning. One action is connected with a next one in a sequence of means-end steps aiming at an ultimate goal. Thus, the problem is one of heuristics.

Relevance in deliberation is determined by how the sequence of practical reasoning links up to the original issue of the dialogue. It is the fitting together of the goals with the actions judged to be means of carrying out these goals, that is, the sequence of practical reasoning that defines relevance in a given case.<sup>9</sup> Relevance, in such a case, can only be judged by the information that is available on the problem that is supposed to be deliberated about, on the agents' goals, and on actions they have taken or are planning to take.

In such cases, an action is often assessed as relevant or not on the basis of nonexplicitly stated links in the sequence of practical reasoning resulting in non-explicit premises or conclusions that can be filled in, on a presumptive basis, by means of *scripts*, or normal ways of doing things that are familiar to both the participants and the observers or interpreters of a case. For example, suppose

---

<sup>9</sup> The account of relevance in a deliberation appears to be somewhat similar to the definition of the concept of relevance given by Gorayska and Lindsay (1993, p. 306). According to this definition, an element *X* of a plan *Y* is relevant to *Y* if, and only if, the plan is sufficient to achieve the goal. However, Mey (1995) cites some problems in this definition that indicate it needs to be revised.

that in the context of case 5.3, it is stated that I am turning the doorknob of my office door. Though it may not be explicitly stated in the discourse of the case, we all know that turning the doorknob is the normal way to open a door, so we can infer that my subgoal is to open the door.

The literature on plan recognition has brought out an important way that relevance is different in information-seeking dialogue and in deliberation dialogue. To grasp the difference, one must begin by appreciating the special nature of deliberation as a type of dialogue. Deliberation is concerned with sequences of actions leading to a goal. Such action sequences can be very complex, and there may be many steps in the chain of reasoning. For this reason, what is called *focusing* is very important in deliberation dialogue. Focusing can be explained as the process of concentrating attention on a subset of inferences within a much longer chain in a knowledge base. Grosz (1981) showed how focus shifts can be suggested linguistically by clues or indicator words like *incidentally*, or *as I was saying*. Focusing has been studied in AI in expert-apprentice task dialogues. In such dialogues, a focus space is closed when a subtask is completed, and a new active focus space is opened when the dialogue moves on to another subtask.

An example from such a dialogue given by Carberry (1990, p. 50) illustrates how focus shifts work. Suppose that the expert and the apprentice are discussing the general task of removing a wheel. In order to remove the wheel, various more specific subtasks might have to be carried out. One such subtask might be loosening the nuts that presently hold the wheel onto the vehicle. The deliberation might then open up a new focus space dwelling on the means for carrying out the specific subtask of loosening the screws. Once this new focus space is activated, the expert and apprentice can discuss what type of wrench should be used, and so forth.

The movement from one focus space to another is very important for understanding relevance in deliberation dialogue. The reason is that a task might seem clearly relevant in one focus space, but when one shifts to a different focus space it might not seem relevant at all. Yet, it might be relevant, and be seen to be relevant, once the focus shift in the larger context of the deliberation dialogue is taken into account. Relevance in deliberation dialogue typically involves different levels of generality and abstraction in a chain of practical reasoning. To connect up the general and the specific, domain-dependent knowledge of all the different minute steps in a detailed task needs to be brought together in a single focus. Then this block of knowledge needs to be related to some other block in a different focus.

Relevance in information-seeking dialogue is different from relevance in deliberation because focus shifts of the kind so typical of deliberation, as just indicated, are not nearly so ubiquitous in information-seeking dialogue. In that type of dialogue, "the information-seeker's utterances are not tightly constricted by the order in which actions in the task will eventually be executed" (Carberry,

1990, p. 52). In deliberation dialogue, the participants tend to concentrate on a particular subtask and finish discussing it before shifting to a new focus. In information-seeking dialogue, questions tend to move around more randomly without being tied so closely to a task order. Carberry (p. 52) presents this contrast as an empirical hypothesis supported by dialogue transcripts, but it is also an important clue to understanding how to normatively analyze and evaluate relevance in specific cases of argumentation. To analyze and evaluate relevance in deliberation dialogue, knowledge of domain-dependent action routines is vitally important. Understanding focus shifts at different levels of a lengthy sequence of actions is also necessary. To analyze and evaluate relevance in information-seeking dialogue, such detailed knowledge tends to be less important.

The goal of an inquiry is to prove that a particular proposition is definitely true or false, based on premises that are known to be true and established as true or if that goal is not attainable, to prove that this particular proposition cannot be proved true (or false) even though all the relevant evidence has been gathered and assessed. The method of the inquiry is to draw conclusions only from premises that can definitely be established as true or false. The aim is to base the inquiry on solid foundations, so there is no need to continually go back and question or retract conclusions, once they have already been established.

In a persuasion dialogue, commitments can be retracted in many instances. In fact, the property of openness to retraction is an important characteristic of the rational attitude of a participant. In contrast, the inquiry is *cumulative*, meaning that once a particular proposition is accepted as true at any particular point in the sequence of argumentation, then that proposition must remain true at all successive points in the inquiry. Cumulateness means essentially that the participants in an inquiry are not supposed to go back and change their minds, once they have accepted a proposition as proved.

Cumulateness is, of course, an ideal of the inquiry as a normative model of dialogue. In a real case, for example, in scientific research, retractions do occasionally occur. But to the extent that a case of argumentation in scientific research is modeled normatively as an instance of inquiry, such a retraction would be admitted with some hesitancy and would be regarded as evidence of a "mistake," although perhaps an understandable one.<sup>10</sup>

The inquiry was recognized by Aristotle as a type of dialogue context of argumentation. He called it demonstration (*apodeixis*), writing in the *Posterior Analytics* (71 b 26) that in a demonstration, the premises must be "primary and indemonstrable" so that in the sequence of reasoning, the premises are better

---

<sup>10</sup> Generally announced or published findings in scientific research are retracted with a considerable degree of discomfort, as though retraction is something that is very much to be avoided if possible. See Broad and Wade (1982, pp. 181-192).

known than the conclusion and prior to it (71 b 29). The most familiar ancient example of the inquiry as a model of argumentation is Euclidean geometry. The premises are axioms that are primary and indemonstrable. They are laid down as starting points for the sequence of reasoning in the inquiry and each is assigned a number. Then all theorems derived from the axioms by logical rules of inference are numbered.<sup>11</sup> Then the idea is that each new theorem derived from the previous axioms and theorems is assigned a number lower than any of the previously demonstrated theorem. Thus the numbered sequence exhibits a “pecking order” of derivations. Since all the axioms are laid down as nonretractable, and each theorem follows deductively from axioms or previously proved theorems only, there is never any need to go back and retract a conclusion. Once a commitment has been accepted at a prior point in the sequence of argumentation, it never needs to be retracted.<sup>12</sup>

There are, of course, very genuine disputes in the philosophy of science on whether scientific research really takes the form of an inquiry. At one time, the view that it takes the form of an inquiry was much more popular. Certainly, scientists, when they describe or explain scientific research to their students or to the public, often invoke the model of the inquiry. It is, perhaps, a sort of motivational icon for prospective scientists. However, the view that actual cases of scientific research and discovery take the form of the inquiry is currently not a widely held view among philosophers and sociologists of science, who tend to see scientific dispute resolution more along the lines of a persuasion dialogue (or even an eristic type of dialogue, in some instances).

Relevance of argumentation in an inquiry is determined by the stage the inquiry is in. At the initial stage, the problem for investigation is defined. Then there is the stage of collecting the data, which need to be verified and formulated. Then comes the stage of formulating a tentative hypothesis that would account for the data presently collected. Next comes a stage of testing, to bring in new evidence that bears specifically on the stated hypothesis. Finally, during an argumentation stage, comes the establishing of conclusions, where the hypothesis is evaluated and is shown to be verified or falsified by the total body of evidence collected.

The final stage is the report on these results, typically by writing them up in an orderly way and communicating them to other researchers and to a wider public. Even this stage, in a particular case, can be regarded as a part of a larger disciplinary context of inquiry where a field of knowledge moves forward. Relevance in an inquiry is sequential in that any argument or hypothesis or question is relevant to the extent that it is related to a prior sequence of propositions that have already been verified or falsified. To be relevant, an

---

<sup>11</sup> See Mackenzie (1980).

<sup>12</sup> Hamblin (1970, p. 76).

argument must have a function in moving the inquiry forward in a cumulative buildup of evidence.

Now we have reached the stage where it is possible to appreciate how an argument can be relevant when used in the context of one type of dialogue, but not relevant when used in a different type of dialogue. Next, we need to consider more complex kinds of cases where there has been a transition from one type of dialogue to another. An argument may have been relevant in the first context of dialogue, but then what happens? In some cases, it remains relevant even after the transition to the second type of dialogue, but in other cases, it does not.

## 6. DIALECTICAL SHIFTS

In some cases, in a given text of discourse containing an argument, there can be a shift from one type of dialogue to another during the course of the argument.

*Case 5.4:* A homeowner and a cement contractor are negotiating on the cost of putting in a concrete basement for a house. They are discussing how thick the cement wall and flooring should be in the basement and what the cost of the cement should be. The homeowner then asks a question. What thickness of cement does the building code require? The contractor takes out a document that states building code requirements for basements and begins to read the section on concrete in basement structures in houses.

In this case, the argumentation initially took place in the framework of a negotiation dialogue, but then as the contractor began to read from the building code manual and the homeowner asked him about what the various statements in the code meant, the exchange shifted to an information-seeking type of dialogue. In this case, the shift was a beneficial one because the negotiations could proceed on a more informed basis, once it became known to both parties what the building code requirements were. Then they could resume their negotiations. In case 5.4, there was a kind of fitting or so-called functional embedding of one dialogue into the other. So even though the argumentation had shifted from a negotiation dialogue to an information-seeking dialogue, it continued to be relevant. Such cases pose a key problem for the analysis of dialectical relevance of argumentation. Why do some arguments remain relevant after a shift to a different type of dialogue whereas others cease to be relevant after the shift?

Several different kinds of dialectical shifts are studied in Walton and Krabbe (1995, pp. 100-116). One involves closure by agreement, as in the case of the discussion in a business meeting that is continued in a more informal way



in the bar, after the meeting has ended. Or the subject of the discussion may even shift. For example, the participants may have been discussing the issue of marketing a product during the meeting, but in the bar, they start discussing the soccer finals. This type of dialectical shift is called a *deplacement* in Walton and Krabbe (1995, p. 102), meaning that there is a sharp and definite border, and once over the border, the one type of dialogue is set in place while the other one is completely discontinued.

A comparable kind of shift is the interruption type of case, cited in Walton and Krabbe (1995, p. 101), which could be called the bike path case. In this case, Karen and Doug were cycling along the bicycle path critically discussing the pros and cons of living in a house versus a condominium. During the conversation, they came to a fork in the bike path, with signs indicating which town each path went to. They stopped and had a discussion about which way to go. In this case the shift was necessitated by a practical need to make a decision. Karen and Doug were initially having a critical discussion about the condominium issue. But then there arose the need to engage in a deliberation type of dialogue on which path to take. Once a decision was made, and the deliberation was concluded, they could then resume the critical discussion. In this case, deliberations stopped the critical discussion temporarily. But the latter could easily be taken up again, once the decision was made on which path to take.

The bike path case represents a sudden type of dialectical shift, but some shifts are gradual. For example, suppose two politicians are having a debate in the form of a critical discussion on the issue of whether reducing taxes will stimulate the economy. And suppose that in the middle of this debate, one debater attacks the other personally, using an *ad hominem* type of argument. The other politician is highly offended by this attack and launches into a similar type of personal attack on the first politician. One calls the other a liar, and the other accuses his attacker of having sex outside of his marriage. Then the two, both of whom appear to be highly offended by the attack of the other party, begin to engage in a quarrel, consisting of intense personal attacks on each other. In this kind of case, the shift from the critical discussion to the quarrel could be quite gradual. But once the quarrel has become intensified, all traces of any critical discussion may disappear. Such a gradual shift is called a *glissement* in Walton and Krabbe (1995, p. 102).

Some cases of the glissement are destructive in the sense that the second dialogue is not contributing to the goals of the first, and may even be interfering with the realization of those goals.<sup>13</sup> A classic case is the following example (Walton, *Place Emot.*, 1992, pp. 217-219):

---

<sup>13</sup> This account derives from the precisely worked out theory of dialectical shifts given in Walton and Krabbe (1995).

**Case 5.5:** In 1989 the union of Eastern Airlines had gone out on strike, and negotiations between union and management were underway. During the negotiation period, the union began to portray Frank Lorenzo, the CEO, as a symbol of greedy and ruthless management. Lorenzo had tried to cut costs by reducing wages, and the union, in their media releases, painted a picture of him as a “brutal unscrupulous aristocrat”. Lorenzo, a quiet and reserved person, who was in fact thoughtful and considerate, did not really deserve this attack. But the *ad hominem* attack had an emotional effect. As it escalated, the workers became obsessed with it, yelling out whenever they saw a picture of Lorenzo on TV, “There’s the slimeball!” As a result, the potential for compromise in the negotiation was lost in a prolonged deadlock, and Eastern went into bankruptcy.

In this case, there was a gradual shift from the negotiation dialogue to a quarrel. Here, the shift from one type of dialogue to the other was illicit, in the sense that the quarrel blocked the possibility of going ahead with a successful negotiation. The shift was instigated as a tactic of argument by one side, but in the end, the outcome was not good for either side.

Dialectical shifts can be harmless where both parties in an argument clearly realize when a shift from one type of dialogue to another has taken place. But deceptive dialectical shifts are often associated with miscommunications and fallacies. In many instances, one party has exploited the other party’s unawareness of a dialectical shift to make an argument seem to be correct when it is not. The argument might be perfectly appropriate in one context of dialogue, but if the argument has subtly shifted to another context, it might only appear to be a good argument, when really it is not.

In cases of this sort, where a subtle dialectical shift has occurred, what a critic needs to do is to evaluate the argument from a normatively retrospective perspective. Two questions need to be asked: (1) What is the context of dialogue in which the argument is actually situated in the given text of discourse in the particular case? (2) What type of dialogue were the participants supposed to be engaged in at the outset (as far as we can tell from indications given by the text and context of the case)? By comparing the evidence and the answers to these two questions, an evaluation can be made of the argument to judge whether there has been a dialectical shift in the given case. It is this sort of retrospective dialectical evaluation that is needed to furnish the evidence for judging cases of informal fallacies (or cases where one suspects a fallacy may have been committed).

These cases represent what could be called an external kind of shift, in which there is a temporal movement. First there is one type of dialogue, and then there is another. There are also internal kinds of shifts, in which one

dialogue is contained within the other. The one is an enveloping structure around the other. One of the most interesting of these types of shifts is the kind of case in which the one dialogue is functionally embedded in the other. For example, deliberation dialogue is typically based on information about the factual situation in which the decision of the deliberation needs to be made. Suppose a group of politicians are deliberating on whether they should vote on a bill that legislates building a new dam. There is a good deal of information that is relevant to any attempt to engage in intelligent deliberations on this issue. Experts may be brought in to provide information. How much will the dam cost? How will it help industry? How much revenue will it bring in, for example, in the form of hydropower? What will be the effect of the dam on the environment? How many people will be displaced? How long will it take to build the dam? Once some reliable information is gathered on these questions, the deliberation will be much more intelligent and informed. In such a case, the information-seeking dialogue, if successful, will actually improve the quality of the deliberation dialogue. So even though there are shifts from deliberation dialogue to the information-seeking kind at various intervals of the debate, these shifts will actually improve the progress of the deliberation, as opposed to blocking it or impeding its progress. This kind of shift represents a functional embedding of one dialogue within another. The information-seeking dialogue is embedded within the deliberation dialogue because it interjects information that is useful in the deliberation.

Yet another type of shift of a kind considered by Mackenzie (1981) occurs in a kind of case where one party in a discussion accuses another of committing a fallacy. This criticism then leads to a discussion on a second level, a discussion about the permissibility of an argument move made by one participant at the first level (Krabbe, 2003, p. 7). In such a case, there is what might be called a shift to a higher level of discussion. The second discussion is a metalevel one about the discussion that earlier took place at the first level. There might even be, in some cases, a hierarchy of levels (Krabbe, 2003). This kind of shift could be extremely helpful in many cases because the problem that occurred at the first level could be clarified and resolved at the second-level discussion. Then the first-level dialogue could move forward successfully, without fallacy or miscommunication.

Some shifts are *licit*, meaning that the shift from the one dialogue to the other contributes to the quality of the first dialogue or at least does not block or interfere with its progress. Other shifts are *illicit*, meaning that the advent of the second dialogue blocks or interferes with the realization of the goal of the first. For example, the *ad hominem* quarreling in the case of the political dialogue about the dam construction could be an illicit shift if it blocks the progress of the critical discussion the two politicians were originally supposed to be engaged in. Such an illicit shift would indicate that the *ad hominem* arguments were not relevant to the original critical discussion.

As shown in Walton and Krabbe (1995, pp. 108-117), illicit shifts are associated with many of the traditional informal fallacies. For example, the use of threats is associated with the traditional *ad baculum* fallacy. But sometimes the use of threats is appropriate, or at least allowable, in argumentation. For instance, making threats of various kinds is an allowable tactic in negotiation dialogue. In collective bargaining talks, to cite a common type of example once again, the union may threaten to go out on strike, while management may threaten to reduce worker benefits. Not all threats are tolerable in such discussions, but many of the arguments used by both sides are, in fact, indirect threats of one sort or another. Within the framework of a negotiation dialogue, use of arguments making threats could be seen as reasonable, or at least not so bad that they should automatically be classified as fallacious. The situation is quite otherwise in a critical discussion. Suppose we are having a philosophy seminar on the issue of abortion, and I argue that if you persist in your view of the matter, I will have an "action squad" beat you up and throw you out of the room. Such an argument would be regarded as so inappropriate that it almost approaches the ridiculous. The threat, in the context of the critical discussion, is obviously irrelevant and inappropriate. It would be classified as an instance of the *ad baculum* fallacy.

Given that *ad baculum* arguments are so highly inappropriate in the context of a critical discussion, one might wonder how they work as deceptive tactics that would actually fool anyone. One explanation is that because they are not inappropriate in negotiation dialogue, this apparent respectability may transfer over into persuasion dialogue. Another is that even though the use of a threat may be a transparently inappropriate argument in a persuasion dialogue, from the point of view of a practical deliberation, the target of the threat may be well advised to pay attention to it or even to comply with the demand of the threatener. Thus, the problem of evaluating *ad baculum* arguments often involves an awareness of various subtle and concealed kinds of dialectical shifts and relationships between different kinds of dialogue. These remarks bring out some interesting aspects of shifts. Sometimes a shift is unilateral—that is, forced by one side without the prior agreement of the other. In some cases, as well, a shift can be deceptive; that is, one or even both parties may be unaware that it has occurred. In such cases, the possibilities of misunderstanding and trickery can be the basis for committing a fallacy.

## 7. FUNCTIONAL EMBEDDINGS

Certain typical kinds of functional embeddings are normal in certain types of dialogue. There are many different examples, but perhaps most noticeable is the dependence of other types on information-seeking dialogue. For example, van Eemeren and Grootendorst (1984, p. 167; *Argument. Comm. Fallacies*, 1992, p.

159) have cited the importance in the critical discussion of what they call an ITP, or intersubjective testing procedure. At the opening stage of a critical discussion, both participants can agree on some body of data they take to be reliable. This body of data can then be used to check or test claims made by either side. What this means is that during any critical discussion on any subject, participants will agree to accept what they consider as factual sources of information. For example, suppose the critical discussion is about the issue of whether having a common European currency is a good idea. One party is against the idea and the other is for it, but both sides may agree to accept some basic information about the economic situation and about currency conversation. For example, they may agree to accept as fact whatever an encyclopedia, or some reference book on economics, says about currency conversion. Or they may consult an economist to fill them in on the relevant facts and statistics, and they may agree not to challenge any of the factual and statistical information the economist vouches for. The economist may agree not to interject any personal opinions on the issue and merely to act as a source of what is generally accepted and documented as factual within the field of economics. The participants in the critical discussion are free to question or challenge anything the economist tells them. But the presumption is that they will generally accept whatever the economist says is factual, unless they are unclear about what it means or they think there is some good reason to raise questions about the evidence backing up the claim.

The presumption in this kind of case is that the infusion of information about the economic facts of the case will improve the critical discussion of the issue of having a common European currency. But why should we think so? The reason is that many of the arguments on both sides will turn on factual questions, for example, on how well such currency conversions have worked in the past, or on how banking practices will be changed, or on what the effects will be on world markets. Many of the arguments on both sides of the critical discussion will take the form of argumentation from consequences. One side will argue that conversion to a single currency will have bad consequences and is therefore a bad policy. The other side will argue that conversion to a single currency will have good consequences and is therefore a good policy. But the question of whether such consequences will or are likely to really occur is a factual question, or is at least based on many factual considerations of the kinds that are known to, or at least studied by economists. Therefore the critical discussion is made much more interesting and useful to the extent that it is based on what is known, or thought to be known, about such factual matters. A purely theoretical or abstract discussion of the issue, which did not take all these known facts into account, would be much less interesting and would throw much less light on the issue.

In a case like this, the arguments used in the critical discussion will mix together two kinds of premises although the distinction is not absolute. Some

premises will reflect the goals and values of the participants. Others, however, will be factual in nature. They may be statistical claims, for example, or historical claims about what happened in similar cases in the past. Or they may be technical assertions about how banking and international trade works. Such “factual” claims have values of various kinds built into them. But they are “factual” in the sense that they do not incline too strongly one way or the other on the issue of whether Europe should have a single currency. They are not overtly claims that such an idea is good or bad. They represent information that is open to challenge but is of a kind that would be accepted as falling within the field of economics. The problem here is that you can not press down on the fact-value distinction too hard, or it will collapse. Nevertheless, the participants in a persuasion dialogue can agree to accept propositions vouched for by some source as “factual,” so that they agree, in general, not to dispute such facts. That way, they can confine the dispute to the issue being discussed. This discussion will move along better because it will not constantly bog down on the resolution of factual questions that are unanswered, tending to stop the discussion at that point and leaving the issue unresolved.

How then, in such a case, is the one dialogue functionally embedded in the other? The answer is that many arguments in the critical discussion will be partly based on premises that can be judged by going to the source of information. For example, suppose that one side argues that currency conversion is a good idea because it has worked in the past, always improving the economies of all participating countries. The other side might challenge that generalization and ask for proof. To provide support for the claim, the first participant may then turn to the economic expert source, who may cite details of many known cases. The participants in the critical discussion can question the details of how the cases are described, but basically they are obliged to accept what the source tells them as being generally accurate as a description of the known facts. They can then use this information as premises in their arguments in the critical discussion. So, for example, one participant might argue as follows:

1. Conversion to a common currency improved the economies of all participating countries in all cases where it has been adopted.
2. Therefore conversion to a common currency will improve the economies of all countries in the present case.
3. Improving the economies of all the participating countries is a good outcome.
4. Therefore, conversion to a common currency is a good idea.

Premise 1 is factual in nature, as compared to premise 3, for example, which is more in the nature of a value-statement. In the critical discussion, presumably both parties would agree to 3, or nobody would contest this statement. However,

premise 1 is different: it favors one side as opposed to the other, or at any rate, its potential for use in argumentation favors one side over the other. Even so, both sides could accept it as a factual claim. One side could ask the economist, “How do you know that?” or “What other cases are known and do they all support your generalization?” The economist can then cite cases as supporting evidence to back up her general claim. The details of these cases may be subject to further questioning. But still, neither side would be disposed to doubt that what the economist has said is basically true because the economist is an expert. And supposedly, she is a neutral expert who is not letting her own values bias the information she provides as an expert who has been consulted to present the known facts of economics.

The structure of the argument can be represented as an argument diagram. An arrow goes from 1 to 2, indicating that 1 is a premise in a single-premised argument for 2. Then 2 also functions as a premise in a linked argument. In this linked argument, 2 and 3 are the two premises linked together to support the conclusion 4. Given further details of the argument, other premises can be seen as supporting 1. These supporting premises are the claims made by the economist to back up her generalization. There could be a whole network of further arguments here, all going in to 1 as their conclusion. Precisely at 1 on the diagram, a dialectical shift has occurred. All propositions below 1 and even 1 itself, are part of the critical discussion on the subject of whether European currency conversion is a good idea. All the propositions above 1—that is, the various arguments put forward by the economist to support 1—lead into 1 as the root of a tree. Suppose, for example, that the economist offers two linked arguments to support her claim that 1 is true. Let’s call the premises of the one argument 5 and 6, and the premises of the other argument 7 and 8. Then the argument diagram in figure 5.2 can represent the structure of the argumentation.

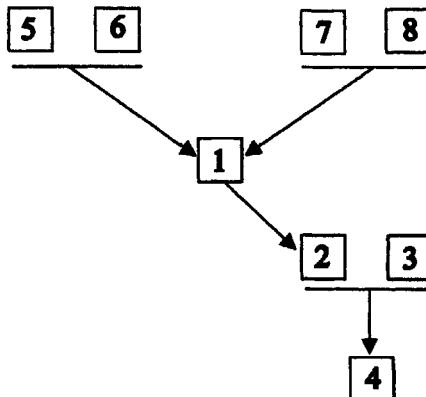

**Figure 5.2:** Argument Diagram of the Currency Case

In figure 5.2, the dialectical shift can be located at the point where 1 is indicated. All the argumentation above this point is part of an expert consultation dialogue—a species of information-seeking dialogue in the classification of Walton (1998). The argumentation in this dialogue also includes 1 itself. But all the argumentation below 1 takes place within the critical discussion. Of course, 1 itself is included as a premise in this argumentation. So 1 is the common point in the argumentation between the two types of dialogue.

What we see here is that the chains of argumentation used by one side or the other in a critical discussion use some premises that are imported from the information-seeking dialogue. These premises are combined with others that are less factual in nature and that represent the views and values of one side or the other in the persuasion dialogue itself. Thus, the chain of argumentation combines premises from the persuasion dialogue with premises from the information-seeking dialogue. These premises are linked together to form chains of argumentation leading to the ultimate thesis of one side or the other. As shown by their places in such chains of argumentation, the propositions inserted from the information-seeking dialogue into the persuasion dialogue are dialectically relevant in the persuasion dialogue. They are relevant in the critical discussion because they have probative value within arguments used to support or attack the ultimate thesis of one side or the other. The common currency case shows clearly that this is so and shows how it works.

## 8. THE PROBLEM OF PREMISE AVAILABILITY

The problem of premise availability faces any attempt to formalize dialogue argument, as Reed (1999) has shown. According to Reed (p. 2), the problem of premise availability is expressed by the following question: “Do there exist premises which can support a given conclusion or which can rebut or undercut some argument?” The discovery of reasons that support an argument is a vitally important part of grasping how argumentation works in any given case, for argumentation often has a dynamic quality in the following sense. As the argumentation develops in a given case, conclusions are not just drawn from a fixed or static set of premises. Instead, much of the argumentation is concerned with searching for new premises or for missing premises needed to support a conclusion. In studying the problem of premise availability, Reed (1999) has rightly assigned central importance to argument diagrams of the kind studied by Freeman (1991) and argumentation schemes of the kind studied by Hastings (1963) and by Kienpointner (1992). But argument diagrams are not all that is required to solve the problem of premise availability. There is a contextual element as well. In many cases, a functional embedding of one type of dialogue



into another is involved. To show how, the best way is to take a common kind of case where premise availability is a central problem.

One very important kind of example would be the case of a student or researcher writing an argumentative essay. The student has to pick a topic or question and then think out how he could best present the data he has found so far to prove or support some designated thesis. The type of dialogue would be what I have called persuasion dialogue. The student's task is to find some interesting thesis and then give the strongest possible reasons supporting the truth of that thesis. But, of course, dialogue is also implicitly involved, as I would say it always is in such cases, because the student must also formulate the strongest possible objections to his arguments and then try to counter them as persuasively as possible. This is basically the task of a written essay or paper, of the kind we are all so familiar with.

The student has two problems to confront. One is to find an interesting thesis and argue for that. The other is to collect as much relevant information as possible, from reliable sources that can be documented adequately. This could be called the research component, or collecting of data. It is always a problem with writing any essay of this sort that you have to divide your time between these two tasks. At some point, you have no more time to collect data, and you have to start writing. But then, after having written a rough draft, you may have to go back to the research task and look up some information that has now turned out to be vital to your line of argument.

The problem of premise availability is surely a cycling back and forth between these two tasks. First, you have a thesis to prove,  $T$ . To support  $T$ , you need to find a network of linked and convergent arguments based on premises that can be supported by given evidence. The process for this task is surely abductive in nature. The student has to reason backwards, or look for best explanations, among the propositions that he has already assembled as his data set. But in some instances, this process will pick out propositions not in the database. Then the student will have to do more research and try to find sources that support these propositions or not.

Normally in persuasion dialogue, the task is to find premises that your respondent will accept, or as we say, is committed to. But that is the problem when you are dealing with an individual. If you are doing a history essay, then your professor will tend to accept whatever the main experts in the field are also generally inclined to accept. So your problem is not just one of convincing this individual professor, but of writing a history essay of a sort that would be convincing to professional historians.

Let's consider a specific example. Suppose you have taken as your thesis a counterfactual proposition: If certain individuals in German politics had resisted Hitler more strongly, instead of acting in their own personal interests, Hitler would never have gotten into power. To argue for this thesis, you have to carry out two tasks. First, you have to collect a lot of documented facts about

what happened in German politics in 1933, just before Hitler came to power. Then you have to use these supposed facts as premises to support your thesis. As part of the second task, you have to reply to certain objections to your arguments. For example, someone might object that popular support for Hitler was so strong that he would have gotten into power anyway. You might reply that popular support for the Nazis was in decline at this time and that if Hitler could have been held back just a little while longer, he never would have gotten into power. But once this issue has been raised and both sides have been looked at, you may be well advised to do some further research. You may have to dig up some more facts on the extent of popular support for the Nazis, just before and during the time of Hitler's appointment as Chancellor of Germany. Such facts might be election statistics and any poll outcomes that were known.

Thus, the problem of premise availability involves two related subtasks of argument construction in dialogue. One is the abductive searching for premises, and links between them and your thesis, in your existing knowledge base. The other is the task of adding, at strategic points, to your existing knowledge base. These could be called the abductive task and the information-seeking task, respectively. Of the two, the information-seeking task is less analytically exciting. You find gaps in your argumentation, and the task is simply one of collecting relevant information, if you can, that would seal up the gaps. The abductive task is more exciting. How do you construct a "logic of discovery" to search out the best evidence needed to support your given thesis? Can such a task be automated? It looks like it can, and it appears that the current research in knowledge-based systems is already quite familiar with this type of task. It is the famous technique of "reasoning backwards," or abduction. As Reed shows, it partly uses deductive and inductive reasoning, of the kinds familiar for so long in logic. But it also requires new argumentation schemes—forms of reasoning that are contextual and nonmonotonic and are neither deductive nor inductive in nature. They represent forms of intelligent guesswork of the kind Peirce called abductive. They give a small probative weight for or against a conclusion that is not, by itself, conclusive, but that only has some place in a much larger body of total evidence in a case. What defines *evidence* is a relative matter, and can be subject to change as new information comes into a case. What is vital in any given case is the argument diagram. You not only have small argument diagrams at the local level, in relation to any localized claim, argument, or counter-argument, but you also have two global argument diagrams in any given case. One represents the total evidence for the given thesis. The other represents the total evidence against that thesis, or for the opposite thesis.

Any good method for solving the problem of premise availability would be extremely valuable as a piece of educational technology. It would be valuable not only for its uses in educational software, but also for the theoretical light it would throw on methods of argument evaluation in logic. A method of this kind would throw a lot of light, for example, on the problem of handling linked and

convergent arguments in argument diagrams and the problem of enthymemes. But the problem of premise availability is closely tied to the problem of understanding how functional embedding works. In writing an argumentative essay, there could be a good deal of complex shifting back and forth between persuasion dialogue and information-seeking dialogue at particular points, as evidence to support premises is sought out and brought into the argumentation. A method of modeling this kind of argumentation would not only need to keep track of the chain of argumentation, but also of the dialectical shifts at key points in it. It would also have to give some sort of account of which shifts are based on a functional embedding.

## 9. FUNCTIONAL EMBEDDING AND RELEVANCE

In functional embedding, as the student essay writing case shows, you often have one type of dialogue inserted periodically within another type of dialogue. It is not a clean break or displacement from one type of dialogue to another, but a kind of shotgun effect in which one type of dialogue is peppered with interludes where there are shifts to the other type. The whole argument diagram may be seen as moving toward the ultimate conclusion to be proved in a critical discussion. But some of the premises used in the chain of argumentation leading to that ultimate conclusion may be based on information-seeking dialogue. In such a case, the one type of dialogue is nested within the other. The various small shifts from critical discussion to information-seeking dialogue could be seen as licit because they contribute to the progress of the critical discussion toward its goal.

But how does such a nesting of dialogues work? What makes it licit, when it is licit? And how could we model the nesting of the one dialogue into the other? Another question is what makes the arguments in the information-seeking dialogue relevant, even when they are used in an entirely different type of dialogue—a critical discussion. On the surface, they might seem to be irrelevant because they occur in a different type of dialogue which has different goals. So why do we think they are relevant, in many cases of this sort? The relevance evidently has to do with the functional embedding of one dialogue into the other. But how so? So far, none of these questions has been answered.

Evidently the answers come from the goals of the different types of dialogue. For example, the goal of a critical discussion is to resolve an initial conflict of opinions by means of rational argumentation that is relevant to the issue posed by the conflict. This goal is achieved by articulating the strongest arguments on both sides and weighing them up against each other. But in order to get strong and relevant arguments, you need three elements: (1) premises that your opponent will accept, or can be brought to accept by showing that they are supported by the facts of the case; (2) relevant arguments from these premises to

the conclusion to be proved in the critical discussion; and (3) relevant arguments that are structurally correct—that is, deductively valid, inductively strong, or abductively plausible. The first element relates to the traditional problem of premise availability in argumentation, that is, where you get your premises from. Typical cases show that mounting a successful argument in a critical discussion requires an information-gathering stage.

There are two aspects to functional embeddings that need to be represented when any case of a functional embedding of one dialogue into another is modeled. One aspect is the commonality of premises (propositions) in the chain of argumentation. For example, a particular proposition may have come from an information-seeking dialogue, but it may function as a premise in a chain of argumentation in a persuasion dialogue. Some way of marking this commonality should be part of the formalization. So, for example, in the argument diagram of a given case, even though the larger context is that of a persuasion dialogue, it should be marked somehow that this particular proposition in the diagram came in through information-seeking dialogue. The second aspect is the functionality of the fit between the respective goals of the two types of dialogues. When we move from one type to another, we have to have some idea of how the one goal fits with the other. Then we can move to a consideration of the given case where a shift occurred and see whether in fact there is such a fit, and how the second dialogue contributed to the goal of the first one.

For example, as previously noted, functional embeddings are frequently found in cases of a shift from a persuasion dialogue to an information-seeking type of dialogue or in cases of a shift from a deliberation dialogue to an information-seeking dialogue. Let's consider the shift from persuasion dialogue to information-seeking dialogue first. The goal of persuasion dialogue is to throw light on the issue being discussed by revealing the reasons supporting (and detracting from) the claims on both sides. For example, if the persuasion dialogue is on the ethical issue of euthanasia, a successful dialogue will bring out the strongest argument both for and against euthanasia, thereby deepening our understanding of the issue. But how would the embedding of information-seeking dialogue support or detract from this goal? The injection of irrelevant information would detract from the quality of the persuasion dialogue and simply delay or interfere with its reaching its goal. But relevant information could make the persuasion dialogue much more successful in reaching its goal. The reason seems to be that the issue of euthanasia is not purely abstract. It is partly a problem of how to proceed in a given set of social and medical circumstances. Thus there is a good deal of information about such circumstances that is relevant. For example, consider the information that administration of lethal medication is allowed as a form of euthanasia in the Netherlands, and this policy is not subject to the kind of abuse that opponents of euthanasia so often worry about when they cite slippery slope arguments. This

information may be highly relevant to a persuasion dialogue about euthanasia conducted in a North American context. Why is it relevant? Because there is a place where it fits into the arguments used in such a persuasion dialogue.

Next let's consider the shift from deliberation to information-seeking dialogue. Why are functional embeddings so common in these kinds of cases? The answer comes down to the goals of the two types of dialogue. The goal of a deliberation is to try to discover a prudent course of action in a given situation, in relation to the agents' goals and the agents' information about the particular circumstances of the case. In deliberation, an agent acts on the basis of what it sees as the external circumstances. It can see the consequences of its actions, to some extent at least, and can correct its actions, moving them more toward the goal if it sees them deviating from it. In deliberation, then, an agent's perception of its external circumstances is extremely important. We are talking about an intelligent agent, that acts in a given set of circumstances and takes relevant information about these circumstances into account. Hence, incoming relevant information is vital to the goal of a deliberation.

From consideration of these two kinds of cases, it is possible to formulate a hypothesis about functional embeddings. The hypothesis is that functional embeddings work because the goals of the two types of dialogue fit into each other functionally and support each other. In the embedding of an information-seeking dialogue into a deliberation, for example, the goal of increasing information supports the goal of intelligent deliberation. In the embedding of an information-seeking dialogue into a persuasion dialogue, the goal of increasing information supports the goal of understanding what is at stake in the issue being discussed.

In contrast, consider other kinds of shifts. Consider the shift from a persuasion dialogue to a quarrel. The goal of the quarrel is to bring personal grievances to the surface. Thus typically, the quarrel bounces all over the place as each party attacks the other for alleged personal shortcomings. This dialogue does not support the goal of a persuasion dialogue because the goal of this type of dialogue is to uncover the rational grounds of support of the main arguments on both sides of an issue being discussed. Personal attack is, for the most part, more a hindrance than a help to reaching this goal because it dwells on the character and personality of the arguers more than on their arguments. Quarreling is not an efficient way to conduct a persuasion dialogue. By and large, it tends to detract from, rather than to support, the objectives of a critical discussion, especially if it is protracted, producing lengthy personal attacks and counterattacks on both sides.

Functional embedding is closely related to the concept of dialectical relevance. First of all, functional embedding is often the best explanation of why one argument is relevant to another. For example, information about an agent's particular circumstances can be relevant to some argument that agent is weighing in a deliberation dialogue. It may be relevant precisely because of the

kind of functional embedding just explained. But second, relevance is often an important problem for functional embedding. For example, an embedding of an information-seeking dialogue into a deliberation dialogue may only be functional if the information inserted into the deliberation dialogue is, in fact, relevant in that dialogue. What needs to be appreciated is that this kind of relevance always needs to be judged at two levels: the global level of the type of dialogue as a whole and the local level of how each move in a dialogue fits in with the immediately prior and next moves.

For example, in the currency conversion case, consider the arguments used by the economist to support the claim that such currency conversions have always helped the participating economies in the past. Are these arguments relevant in the line of argumentation in the case as a whole? Yes, they are. But why? At least part of the reason is that the expert consultation dialogue in which they occur is functionally embedded in the persuasion dialogue about the European currency conversion issue. Because the embedding is of a constructive kind, so that the information-seeking dialogue fits into the persuasion dialogue correctly, the argumentation of the economist is relevant even though it represents a shift to a different type of dialogue. What is shown is that dialectical relevance is preserved over some dialectical shifts. It is preserved, it seems, precisely when the one dialogue is functionally embedded in the other.

A hypothesis suggested by this connection of embedding with relevance is that functional embedding of the kind that supports relevance needs to be analyzed in a given case as requiring two factors. First, what is required is a global fit between the types of dialogue. For example, a shift from persuasion dialogue to a quarrel will, in general, not be a fit of the kind that will underlay a functional embedding, whereas a shift from a persuasion dialogue to an information-seeking dialogue could be a good fit. Second, what is required is a fitting together of the various parts of the argument around the point in the dialogue where the shift occurred. For example, if premise availability is a problem at a particular point in a persuasion dialogue and information is needed to supply key premises in a line of argumentation relevant in the dialogue, then the fit could be a good one. Two tools are needed to formalize the structure underlying this kind of local fitting together of parts in an embedding. One is the argument diagram. The other is the sequence of argumentation at the local level, as represented by the formalization in the picture-hanging dialogue. Each move in the dialogue needs to fit in with previous moves at the local level and also fit in with the next moves.

## 10. PROBLEMS TO BE SOLVED

Judging whether an argument, or part of an argument, is relevant or not in a particular case depends on a prior evaluation of what type of dialogue the

argument is supposed to be a part of. That is the general conclusion of this chapter. But this conclusion has posed a number of problems that need to be solved if some useful theory of dialectical relevance is to be developed. Each of the six types of dialogue is a normative model of rational argumentation. But such normative models represent ideals of a certain type of communicative speech exchange. They are not conversations or arguments that actually occur in a case. In bringing them to bear to support a judgment that an argument is relevant or not, one is making an assumption about the purpose of some actual event. Such an assumption can be open to question on different kinds of grounds in different kinds of cases.

In many cases of arguments used in a given case in everyday conversational exchanges, the conversation may be of a casual kind, where the participants have reached no clear agreement on the type of dialogue they are supposed to be engaged in, and there is little or no decisive evidence in the text of their discourse to point clearly to one type of dialogue. In such cases, the best a rational critic can do is to arrive at a conditional evaluation of the form: if the participants are supposed to be taking part in a dialogue of such-and-such type, then this particular argument that one of them put forward in their actual exchange is relevant, or is not relevant, in the context of that type of dialogue. Such a conditional evaluation always leaves the defender of the argument a way out. He can reply, "Well, that is not the type of dialogue I thought we were supposed to be engaged in, so your criticism that my argument is irrelevant is not justified." But even though a conditional evaluation is not conclusive as a refutation or criticism of someone's argument, it can often be highly informative and helpful as a criticism. This kind of problem, then, is not a serious obstacle to developing a dialectical analysis of relevance that would be usefully applicable to argumentation in everyday discourse.

A second group of problems relates to cases of argumentation in which dialectical shifts occur. The problem posed here is to develop some kind of systematic method that can be used to support judgments that an argument is relevant or irrelevant, as used in a given case.

The general problem addressed in this chapter is to determine how one dialogue fits into another in a relevant sequence of argumentation where one type of dialogue is superseded by another. The problem is to devise some kind of method for analyzing and evaluating relevance and irrelevance in cases of argumentation where this kind of shift has occurred. Argumentation theory has utilized a number of potentially useful methods in recent years, arising out of the standard project of evaluating arguments in relation to how they were used in a context of dialogue. Certain common techniques are widely in use. The tableau method (Hamblin, 1971), Rescher (1977), Hintikka (1979), Mackenzie (1981), Barth and Krabbe (1982), Carlson (1983), which derives from the Lorenzen School, models a dialogue as a pair of columns in which each ordered pair of moves is a row in the tableau. The method of argument diagramming

(Freeman, 1991; Walton, *Argument Structure*, 1996) is also widely in use. Applying this method, a chain of argumentation is modeled as a directed graph where the vertices are premises and conclusions (Walton, *Argument Structure*, 1996). But these methods do not appear to be adequate to deal with several sophisticated kinds of problems that are becoming more and more familiar in attempts to evaluate arguments. One problem is to understand how argumentation taking place in one type of dialogue can carry over and be fitted together with its continuance as argumentation following a shift to another type of dialogue. In some cases, there can be a kind of fit or so-called functional embedding of the one dialogue into the other. How can arguments in which such functional embeddings occur be formalized? How can they be grasped and explained as having a discernible structure?

The problems about functional embeddings are related to other problems of modeling and evaluating argumentation. One such problem is that of premise availability, posed by cases in which an argument can only be advanced and supported by finding premises that provide support at the right points in the structure of the argument. Often such premises need to be found by engaging in some kind of search external to the type of dialogue in which the argument was put forward and is initially being discussed. What is shown in the next chapter is that the problem of premise availability can only be solved, or even properly understood as a problem, if it is revealed how it is closely related to matters of functional embeddings of dialogues. Another problem shown to be closely tied up with functional embedding is that of relevance. In many cases, premises used in an argument are supported by other premises that are more remote and may even be questionably relevant. In such cases, evaluating relevance is very often complicated by the fact the new premises brought forward may have come from some source of information external to the dialogue currently engaged in. For example, an expert opinion may be cited as support for an argument used by one party in a critical discussion. The relevance or irrelevance of such appeals is frequently a key issue in relation to many of the traditional informal fallacies.

Solving this whole group of problems in one single program of research would clearly be too much to ask or even hope for. What will be achieved in the next chapter is to build up a method that can be used to identify and analyze argumentation in cases where a dialectical shift has occurred, to determine whether a dialectical and functional embedding has occurred or not. This method offers a new theoretical perspective on problems like premise availability and dialectical relevance.

Finally, there is a third group of problems that has to do with judging relevance in special contexts of discourse. For example, in a political debate or a legal trial, there are special problems in trying to classify the dialogue, using any of the six basic models. One kind of case that commonly occurs is one of *mixed discourse*, where a text of discourse given in a particular case can justifiably be taken to be an instance of more than one type of dialogue, during a sequence of



argumentation where no shift has occurred from one type of dialogue to another. Actually it is a little misleading to exclude shifts entirely here because the kinds of cases of mixed discourse of most importance are conventional types of dialogue that are generally recognized by the participants and their audiences as belonging to a certain type of discourse. Three very common types of argument in mixed discourse are those of legal argumentation, of the kind that takes place in a trial, political debate, and sales argumentation in commercial speech.

Political debate is very much a mixed context of argument. We presume, at least in democratic systems of government, that political debate involves critical discussion of the issues. This assumption often appears dubious, but it is an ideal of any democratic system of politics. But political debate also frequently involves negotiation. Advocacy and the promotion of the special interests of the participants can never entirely be excluded from political argumentation. Additionally, deliberation is more or less involved in political arguments. In fact, the primary example of deliberation cited above was the town hall meeting. As well, eristic dialogue seems to be a part of political debate, in the form of partisan politics and the attacking of political opponents in the heat of confrontation. Thus, although one can detect internal shifts in particular arguments in a given case, generally political debate is a mixed kind of discourse.

Another mixed type of discourse is commercial speech, in familiar cases like that of a sales pitch or a commercial ad, for example, on television. Initially, this type of argumentation may seem like it should be categorized as occurring in persuasion dialogue, but the matter is not that simple. TV ads sometimes involve persuasion, to the effect, for example, that the product is useful or has certain valuable features. In other cases, the purpose of the commercial may be simply to get the viewer's attention or to cultivate brand name recognition. Also, elements of negotiation are involved in ads that may, in effect, offer a certain specific product, or kind of product, to buyers. In general, it may be a mistake to hold salespersons or advertisers to standards of a critical discussion, if they are not really trying to rationally persuade respondents of the merits of their product. Hence the textbook denunciations of commercial ads as committing logical fallacies (cited in chapter 1) are somewhat questionable. Certainly, we in western democratic countries, at any rate, all have the ability to recognize a commercial or a sales pitch when we see one because we are so familiar with this type of discourse in our daily lives. But to clearly and precisely identify the purpose of this type of discourse may not be so easy. Clearly, the purpose is to sell a product, but the ways of doing this by using argumentation in a framework of dialogue seem to be complex in nature.

Another mixed discourse framework is that of legal argumentation. In general, there is a presumption that legal argumentation of the kind found in a trial represents rational arguments of the kind that would normally be found in a critical discussion. Alexy (1989, p. i) even notes that in a decision of February

14, 1973, a panel of the German Constitutional Court declared that all judicial rulings must “be founded on rational argumentation.” Feteris (1999, p. 174) argues that the trial can be modeled as a kind of critical discussion, but also that in certain respects it is more complex than a critical discussion. There is a critical discussion taking place between the plaintiff and the defendant, but there is also an embedded critical discussion between the judge and the defendant. This secondary critical discussion is a special kind in which the judge must remain neutral (Feteris, 1999, p. 174). But there are other participants and other factors in the argumentation in a trial that also need to be considered. The plaintiff and defendant each have an attorney representing him or her. It is an important part of the trial that witnesses supply evidence by giving testimony. The witnesses are questioned and examined by the attorneys. Sometimes the examiner will even attack the character of the witness. The dialogue here is not so much a critical discussion as a probing interview. Thus, the trial is a complex ritual that weaves different kinds of dialogue together in a complex network of embeddings. But basically, the main argumentation can be seen as a critical discussion in which the two sides attempt to persuade the trier. The jury must critically examine the argumentation on both sides and come to a decision.

Another complex aspect emphasized in chapter 1 is that the argumentation in a trial needs to be seen as taking place not only within a set of institutional trial rules. Within this outer framework, it needs to be seen as occurring within some normative structure of dialogue. But what is that normative structure? Surely the hypothesis of Feteris that the trial is basically a type of critical discussion or persuasion dialogue is highly plausible. Each of the two sides has its thesis (claim, action), and each side tries to persuade the trier that all the relevant arguments brought forward to support its claim throw enough probative weight on that claim to secure fulfillment of the burden of proof. So conceived, the underlying structure of the trial is that of a persuasion dialogue. But as noted earlier, one complicating factor is that much of the evidence in a trial is based on witness testimony. This testimony is brought into the trial by a dialogue process called “examining” the witness. Examination, it can be argued, is a species of information-seeking dialogue. If these hypotheses are right, dialectical relevance in a trial needs to be determined within a framework of an information-seeking type of dialogue embedded in a persuasion type of dialogue.

So now we are brought back to the notion of dialectical embedding that was found to be so important to the theory of relevance. To judge whether an argument is relevant or not in a fair trial, it is very often necessary to take a dialectical shift into account. Evidence is typically introduced into a trial through testimony of a witness, in an information-seeking framework of dialogue. But then arguments based on this testimony will be used by the counsel for each side, in a persuasion dialogue that has the aim of persuading the trier to accept some particular conclusion. In judging whether the testimony

is relevant, or should be admitted into the trial, this embedding needs to be taken into account. The judge must try to assess how the testimony could be used in the persuasion dialogue in a chain of argumentation concluding in the ultimate issue to be decided (on one side or the other). Another very significant factor in judging relevance in legal arguments is that there exist many legal rules for evaluating arguments, including rules of evidence and rules of relevance. So in judging a whether a legal argument has committed any fallacies, or whether it is relevant, these special legal rules, as they apply in a particular court, or in a particular type of legal case, need to be taken into account. For these reasons then, arguments in political, legal, and commercial speech require individual consideration as involving mixed discourse with certain special features.

## Evidence and Methods for Making Relevance Judgments

Developments in computing, in multi-agent systems, and in artificial intelligence generally, are at the stage where an applied logic of argumentation would be extremely useful. The problem of finding a method for identifying, analyzing, and evaluating criticisms of irrelevance has not yet been solved. But the cases studied so far have already yielded many components of such a method. In many of these cases, fairly good reasons can be given for judging an argument to be relevant or irrelevant. Yet some cases are open to dispute. In such cases, the proponent will claim that her argument is relevant even if the respondent has criticized it as irrelevant. What sort of evidence could be used to back up reasons for judging an argument to be relevant or irrelevant? What is needed is a comprehensive method that can collect, display, and process such evidence systematically. Such a method is put forward in chapter 6.

This method is based on two subsidiary methods that can be used alone or combined. One is the technique of argument extrapolation, based on the devices of argument chaining and argument diagramming as introduced in previous chapters. Argument extrapolation is derived from the widely used technique in artificial intelligence of chaining an argument forward from premises in a given knowledge base. Argument chaining is already familiar to many as a method of problem solving by searching in artificial intelligence (Russell and Norvig, 1995, chapter 3). This familiar searching procedure is used as the basis of the new method of argument extrapolation. The other subsidiary technique is the profile of dialogue method already in use in argumentation studies (Krabbe, 1992). This method also makes relevance dependent on the type of conversational framework the argument is supposed to be part of. Hence, the use of the term *dialectical* to describe it, referring to the ancient Greek notion of two parties reasoning together in a dialogue in which each respects the views and arguments of the other. What is advocated in chapter 6 as the best method for determining relevance in a case is a combination of these two techniques.

The main purpose of the new method is to judge the relevance or irrelevance of an argument in a given text of discourse. But the method can also be used to construct argumentation in a writing task that is supposed to represent a dialogue like a critical discussion of a particular issue. It can be applied to such an assignment, showing that what is required is a presentation of relevant arguments on both sides of the issue to be discussed.

## 1. THE TARGET CONCEPT OF RELEVANCE

Before attempting to devise methods of determining relevance in given cases, it is necessary to define the target concept of relevance that is supposedly being determined. Many different kinds of relevance and irrelevance can be significant in the study of discourse. Something could be considered relevant if it is important to social and ethical concerns of an audience or advocacy group, for example. In a broad sense, anything that is important for some person or group could be considered relevant for that person or group, in any verbal exchanges they might engage in. It is clear from chapter 3 that if any theory of relevance is to be useful for evaluating arguments of the kind that the logic textbooks aim to critically analyze, in order to detect faults and fallacies, the broad meaning of the ordinary language term *relevance* must be narrowed to a more specific meaning. When the textbooks say an argument or move in argumentation is “irrelevant” in this logical sense, they imply that it does not provide the right evidence or grounds for proving or supporting the conclusion that is supposed to be proved or supported.<sup>1</sup> When such a charge of irrelevance is made in a logic curriculum context, it means that the argument falls short of some standard of rationality that an argument is supposed to fulfill when used to prove something or argue for a point. Similarly, in legal argumentation, probative relevance of the kind described by Wigmore is based on logical relevance.

Another kind of relevance is called *interpretative relevance* by van Eemeren and Grootendorst (1992, p. 142). Empirically oriented researchers—linguists, psychologists, and sociologists—“start from the proceedings in real-life cases of argumentative discourse and identify relevance and irrelevance empirically by describing what the language users themselves appear to consider as relevant or irrelevant”. Van Eemeren and Grootendorst (p. 143) cited a case from Tracy (1982, p. 281), as an example of this descriptive approach:

- Case 6.1:    A: I don't know what to major in.  
               B: uhm  
               A: I'm really torn between the practical and the interesting. I'd probably be able to get a good job if I majored in accounting [ . . . ]. But, I really like anthropology. It's fun learning about all those exotic cultures. But, look at Jim, he majored in anthropology in college. Now Jim's working in an office earning nothing.

---

<sup>1</sup> It is clear from the textbook point of view surveyed in chapter 3 that the central focus of evaluation should be on arguments and the parts of arguments. However, the relevance of questions and replies is also a part of the fallacies curriculum. The question of exactly which units of speech are relevant or irrelevant to each other is taken up in section 6 below.

*B*: Yeah, I ran into him the other day and we decided to play racquetball.

It can be investigated empirically whether an ordinary language user like *A* in this case would regard a reply like that given by *B* (at the last move) as relevant or irrelevant. Empirical testing could show, for example, that *B*'s reply would usually be considered irrelevant by native speakers of English. This type of relevance is interpretative because it is based on what the language users actually judge to be relevant in a given case.

However, the kind of relevance cited by the logic textbooks when they evaluate arguments and judge certain cases to be faulty arguments, or to commit fallacies, is not interpretative in nature. Instead, this kind of relevance is a *normative* kind, that seeks to identify relevance and irrelevance as part of the task of evaluating arguments critically, as used in particular cases in given texts of discourse. This normative type of relevance (or what appears to amount to it) is called *evaluative relevance* by van Eemeren and Grootendorst (1992, p. 143), and it could perhaps also be called *logical* or *critical* relevance. Normative relevance presupposes certain standards for judging an argument as correct or rational, as opposed to logically faulty, in the sense of being invalid, illogical, fallacious, or otherwise falling short of, or violating logical requirements for a correct or rational argument. This target concept of relevance is normative, in that it is meant to apply to judgments in particular cases according to certain standards or norms that represent ideals of how an argument should be rationally used for communicative purposes. The kind of relevance defined in the new theory can be called *dialectical relevance*, meaning that an argument, a question, or other type of speech act is judged to be relevant insofar as it plays a part, or has a function, in a goal-directed conversation that is a dialogue exchange between two participants who are aware of each other's moves. The ultimate aim of a system of dialectical relevance is to be useful in judging cases for material relevance, primarily cases where an argument is central.

To judge whether a given argument is normatively relevant, basically one has to judge whether, as used in the given case, it meets the normative standards of reasonable argument appropriate for that case. To determine what normative standard is appropriate, one has to ask the basic question, What purpose is the argument supposedly being used for? To answer that question, one has to examine the evidence given in the text and context of dialogue in that case and ask what type of dialogue this case is supposed to be part of. Then the more detailed evaluation can go from there, depending on the goal of that type of dialogue.

For example, suppose the dialogue is supposed to be a critical discussion. The purpose of a critical discussion is to resolve a conflict of opinions. Thus, the argument in the given case can be judged to be relevant if it is used in such a way as to contribute to the resolution of the conflict of opinions supposedly at

issue in the critical discussion. The argument is relevant if it contributes to the goal of the critical discussion at whatever stage it was used. It is irrelevant if it does not.

Why should argumentation in a natural conversation be assumed to be goal directed? One might object that a lot of the ordinary conversations we have in everyday life do not appear to be goal directed. Two people may meet in the street and have a casual conversation about whether it is a nice day or not. It would seem to be artificial to describe their conversation as goal directed, implying that the two had agreed in advance to undertake this argument about the weather for some specific purpose. If they switch to talking about something else, is that a bad thing? Should it be criticized as “irrelevant”? If not, the problem is that a criticism of irrelevance seems arbitrary or even unfair.

The solution to this problem is to clearly recognize that judgments about the dialectical relevance of an argument confer a stamp of approval or admissibility on the argument as rational or as used correctly in a given case with respect to its serving some purpose. To say that an argument is dialectically relevant or irrelevant is not to say that it is faulty or fallacious in every respect or that it has been used incorrectly with respect to every goal that the participants are trying to achieve in a given case. There is a parallel here with applying deductive logic to arguments. To say that an argument is deductively valid is not to say that it is a good argument in every respect or that it is fallacy free. For a deductively valid argument could be based on false premises, or it could be a circular argument, or it could exhibit many kinds of faults. To say that an argument is deductively valid is only to say that the argument is correct or rational in a conditional sense—it is to say that if the premises are true, then the conclusion must (by logical necessity) be true too. Comparably, to say that an argument is dialectically relevant in a given case is not to say that the argument is perfectly rational, in relation to any goals that might be important to the participants. It is only to say that it has the potential to be used correctly or rationally in a conditional or instrumental sense. It is to say that the argument has the potential to be used in such a way as to contribute to the type of discussion the participants are supposed to be engaged in. But you can always raise the question of what type of discussion the participants should really be engaged in. You can ask whether the agenda of that discussion ought to be changed if they are to solve the underlying problem they confront.

So if two disputants are arguing about the weather, and one of them suddenly starts to argue about baseball or the price of new cars, the switch of topics is not necessarily a bad thing at all. But from the perspective of the two arguers who hope to resolve their difference of opinions about the weather by using rational argumentation, the switch to baseball may be viewed as dialectically irrelevant. This means that it turns the argumentation away from the direction needed for fulfilling its original purpose. At any rate, we can see that dialectical relevance has its place. Although it is not a requirement of all

human communication, it is a useful requirement for reasoned argumentation of various kinds that are quite important in human communication.

In evaluating particular cases for relevance, the process often seems to be partly empirical because evidence from the text of discourse given in the particular case needs to be assembled to determine what, in fact, is the issue in the case. Such given textual evidence is crucially important in properly evaluating a case. But there is also a normative element in a case evaluation, for the question of relevance always depends on an assumption about the type of dialogue the participants are supposedly engaged in. In general then, there are two aspects of evaluating the case. One is the normative standard that is appropriate for a case. The other is the application of this standard to the particulars of the given case, as these are known from the information available about the case, or that can be inferred from the text and context of discourse.

One question for a theory of relevance is that of what units of speech or reasoning to be regarded as relevant (or irrelevant) to each other. In chapter 4, differences of opinion on this question were evident. On some accounts, propositions were said to be relevant or irrelevant to other propositions.<sup>2</sup> On others however, questions were said to be relevant or irrelevant, or replies to questions were criticized as irrelevant.<sup>3</sup> Still other accounts stressed the relevance of arguments, while others defined notions like premissary relevance, where a premise is judged to be relevant or irrelevant to a conclusion.<sup>4</sup> In these accounts, it is not the argument as a whole that is judged to be relevant to something else, but some part of it, like a premise, in relation to another part, like the conclusion. In the Aristotelian account of the *ignoratio elenchi* fallacy, as portrayed by the textbook accounts in chapter 3, it was generally the conclusion of an argument that was cited as “wrong,” in the sense of not matching up with a premise, or given set of premises, implying that the premises were irrelevant to the “real” conclusion. As Yogi Berra put it, “If you don’t know where you’re going, you’ll end up somewhere else.” In the semantic definition of relevance, it was propositions that were related to each other as having the property of relatedness or not. What units then are relevant or not in the new dialectical theory? The answer is that any type of speech act that can be a move in a type of dialogue—whether it be a question, an assertion, an argument, or a request for clarification—can be judged to be relevant or irrelevant to any other type of speech act (or the same type of speech act) that can be a possible move in that type of dialogue. Thus an assertion can be relevant to a question. Or a proposition that played a part in one move could be relevant to a proposition that played a part in another move. Or a proposition could be relevant to an argument. Or a part of an argument could be relevant to another part. Any given

---

<sup>2</sup> See Berg (1991, p. 420).

<sup>3</sup> See case 8.3 below.

<sup>4</sup> Blair (1992).



move, or part of a move in a dialogue is relevant if it is related to the issue of the dialogue according to the ten criteria presented above. So any two moves, or parts of moves in a dialogue can be relevant to each other in virtue of both being related functionally to the issue of a dialogue.

Now that we have some idea of what dialectical relevance is, we turn to the problem of how to judge it in specific cases. Two main techniques will be used. The first one, called *argument chaining*, was recommended as a tool for the analysis of relevance in argumentation in chapter 5. As shown there, the use of this technique can be greatly assisted by the method of argument diagramming. What will be shown next is that the method of *forward and backward chaining* of arguments is already well known in computer science and is an important technique in planning and in other computer fields where arguments in a database are processed.

## 2. ARGUMENT CHAINING AND LEVELS OF ABSTRACTION

In order to explain the general method of evaluating an argument in a given case for relevance, one needs to understand how inferences are chained together in sequences of reasoning in artificial intelligence. A *knowledge base* is a set of propositions made up of *facts*, sets of simple propositions, and *rules*, sets of conditional propositions. If *A* and *B* are two simple propositions (facts), then 'If *A* then *B*' is a conditional proposition (rule) made up from the two simple propositions *A* and *B*.<sup>5</sup> One form of inference that is deductively valid is *modus ponens*.

(MP) If *A* then *B*.  
*A*.  
 Therefore *B*.

Using *modus ponens*, you could draw the conclusion *B* if the two other propositions 'If *A* then *B*' and *A* were in our knowledge base. By deductive inference, *B* could then be added to the knowledge base.

In artificial intelligence —see (Intelliware, 1986, pp. 29-32) it is customary to make a distinction between two kinds of reasoning called *forward chaining* and *backward chaining* of inferences.<sup>6</sup> To give an example of forward chaining, suppose we want to prove proposition *C*, and it is evident that we have three

---

<sup>5</sup> An example would be an expert system. Logicians call 'if . . . then' propositions conditionals, while in artificial intelligence and the study of knowledge-based systems in computer science, these types of propositions are called rules. For a general account of knowledge-based reasoning in AI, see Russell and Norvig (1995, pp. 149-179).

<sup>6</sup> See also Russell and Norvig (1995, pp. 272-275) for an explanation of how forward and backward chaining works in AI.

propositions in our knowledge base,  $A$ , ‘If  $A$  then  $B$ ,’ and ‘If  $B$  then  $C$ .’ We could then prove  $C$  by the following chain of reasoning:

- ( $R$ )
1. If  $A$  then  $B$  (premise)
  2.  $A$  (premise)
  3. If  $B$  then  $C$  (premise)
  4.  $B$  (from 1 and 2 by *modus ponens*)
  5.  $C$  (from 3 and 4 by *modus ponens*)

This sequence of reasoning used to prove  $C$  is an instance of forward chaining. It is the usual kind of reasoning that is familiar in a course on formal logic.

But suppose the task is a different one. Suppose that we are presented with a conclusion  $C$ , and we don’t know whether it can be proved from our knowledge base or not. But suppose that it is evident that the two propositions  $A$  and ‘If  $B$  then  $C$ ’ are in our knowledge base. Our goal is to prove  $C$  by inferring it from the propositions in the knowledge base. But that can’t be done using  $A$  and ‘If  $B$  then  $C$ ’ alone, as premises. So we look around for an additional proposition or set of propositions that is in our knowledge base and could be used along with  $A$  and ‘If  $B$  then  $C$ ’ to infer  $C$ . As we scan through the propositions contained in the knowledge base, ‘If  $A$  then  $B$ ’ is encountered. Then, using the same sequence of reasoning ( $R$ ) above, we can prove  $C$  from these premises. The same general chain of reasoning ( $R$ ) was used in both instances. But in forward chaining, we moved forward from the premises to the conclusion. In backward chaining, we started with the conclusion and reasoned backwards, asking, ‘What premises could this conclusion be inferred from?’ Reasoning (chaining) forward was described in Barr and Feigenbaum (1981, p. 23) as bringing a “situation, or problem state, forward from its initial configuration to one satisfying a goal condition.” The goal condition is expressed as a statement. They gave the example of a game of chess (p. 23). The initial situation is the placement of the chessmen at the start of the game. The desired goal is a checkmate. In reasoning (chaining) backward, the goal statement is converted to one or more subgoals that may be easier to satisfy. The idea is that once the subgoals are attained, the original problem will be solved (p. 23). Forward reasoning is also described as “data-driven” or “bottom-up,” whereas reasoning backward is described as “top-down” (p. 24). Barr and Feigenbaum add (p. 25) that either process can be represented by a graph in which the various problem states are nodes (p. 26).

Backward chaining is characteristic in the kind of reasoning called *inference to the best explanation* or *abductive reasoning*. An example is given by Spencer-Smith (1991, p. 40):

*Case 6.2:* (1) If there has been a power cut, everything in the fridge will be moldy.

- (2) There has been a power cut.
- (3) Therefore, everything in the fridge is moldy.

If one moves forward, from the premises (1) and (2) to the conclusion (3), this inference is deductively valid (an instance of *modus ponens*). But let us put the three propositions in a different context. Suppose I arrive home from a trip, and on opening the fridge, I find that everything in it is moldy. I ponder the best or most plausible explanation for this revolting development, and by abductive reasoning, I trace it back to the two premises (1) and (2). The most likely explanation is a power cut, on the assumption that a power cut would be sufficient (in the circumstances) to result in all the contents of the fridge being moldy. This kind of inference is a simple example of the backward or abductive inference.

The techniques of forward and backward chaining, as just described, are seen as a knowledge-based technique for proving that a conclusion is true (or false) based on known premises. This kind of technique appears to be applicable to argumentation in an information-seeking dialogue embedded in a persuasion dialogue. Or it could also be applicable to the kind of argumentation used in an inquiry. But what about a case of argumentation in deliberation? Could backward and forward chaining be used in argumentation in that type of dialogue?

Russell and Norvig (1995, chapter 5) describe a kind of reasoning used to solve problems by searching, based on the concept of a *problem-solving agent*, an entity that has a goal and decides what to do by finding a sequence of actions that leads to the goal. For example, an agent may want to get to Austin, Texas, by car. Not knowing the way to get there, he consults a road map. He then searches around for a path on the map—a sequence of routes joining different highways on the map—where the end point of the path is Austin, Texas. There may be different major cities along the various routes between the city the agent is now in and Austin, Texas. The agent first of all has to determine these various routes. This problem is one of *searching*, or looking at the possible alternative paths from the initial state to the goal state (Russell and Norvig, 1995, p. 70). A *search tree* (p. 71) represents the different alternative sequences of action starting from the initial state, which is the root of the tree. Many different search strategies are described by Russell and Norvig. For example, in one type of search strategy (p. 77), if you start at the initial point, and seem to be moving toward the goal, but then hit a “dead end,” you can go back toward the lower levels of the tree and start searching again. As indicated in chapter 5, these search strategies are called *heuristics* in AI. Pearl (1985) has shown how such search strategies provide a framework for chains of reasoning aiming at a goal.

But how could this method of searching, whether it be the knowledge-based search for proof or the problem-solving search by an agent, be applicable to determinations of relevance? The key to applying heuristic searching

techniques to the problem of relevance is that a determination of relevance in a particular case involves two aspects. One is the global issue of the dialogue, supposedly stated or indicated as part of the context of use of an argument in a given case. The other is the chaining of argumentation (backward and/or forward) from the given speech act (which is to be judged to be relevant or not) to the global issue. The determination of dialectical relevance of an argument (or other speech act), in a given case, needs to chain the argumentation forward to the issue. The issue, or the goal of the agent in the case of a deliberation, can be represented as a particular proposition or state. For example, if it is whether or not tipping is a good thing, then the particular proposition to be proved, as the ultimate goal of the argumentation, might be 'Tipping is a good thing.' Or if the dialogue is a problem-solving deliberation, the ultimate goal may be to arrive at Austin, Texas. This goal, or ultimate proposition to be proved in the case of a persuasion dialogue, represents the end point of the searching procedure.

The chaining from the given argument to the ultimate issue in a case may be hard to carry out if many steps in the argument have not been filled in yet. In addition to chaining, there is another technique that is very helpful. This has to do with the level of abstraction of the ultimate issue. The notion of abstraction is very important in AI planning systems. So-called hierarchical plans specify subplans within plans at different levels of abstraction.

For example (Russell and Norvig, 1995, p. 368), the most abstract goal at the highest level of planning might be to launch a space capsule into orbit. At a lower level, there might be a subplan to prepare a booster rocket. Within this subplan, "there might be a dozen intermediate levels before we get down to the level of executable actions" (p. 368). At this lowest level of abstraction, there are very specific actions, like putting this bolt into that hole and fastening it with this nut. So at the top level of abstraction in the hierarchy, there are very general goals. But at the bottom level, there are very specific actions that need to be carried out in order to make the plan work.

The concept of hierarchical levels of abstraction in chains of goal-directed reasoning is important in robotics (Albus, 1981, pp. 103-108). How abstract or concrete a proposition is can vary. In other words, there are degrees of abstraction, in the sense that one proposition can be more abstract (or more concrete) than another. For example, the proposition, 'Bob Smith, the defendant, hit Ed Jones over the head with a rubber chicken at 3:00 p.m. in Vancouver on August 22, 1995' is even less abstract (more concrete) than the proposition 'Bob Smith hit Ed Jones.' It is also possible to have a chain of propositions that are all related to each other, where each is more abstract than the one above it and less abstract than the one below it.

One phenomenon that is common to many cases cited in previous chapters is that an important aspect of the perception that one proposition is not relevant to another is the mismatch in the level of abstraction of the two propositions. An *abstract (general) proposition* is one that refers generally to a

class of cases or type of case without making specific assertions about a particular case. A *non-abstract (concrete) proposition* is one that makes specific assertions about the particulars of a given case, for example, the specific times an event or series of actions occurred, the place it occurred, or the particular person alleged to have carried it out. For example, in case 1.3, the proposition, 'Murder is a horrible crime' is an abstract proposition. But in the same case, the proposition, 'The defendant is guilty of murder' is a concrete proposition because it refers to a particular person. What is common to many of the cases studied in previous chapters is that the issue in the given case is a concrete proposition, and then the speaker, like the legislator in case 1.2, launches into a discussion of a related but more abstract issue. This mismatch of levels of abstraction is an important clue to judging relevance and irrelevance.

Curiously, the notion of levels of abstraction that is so important in AI was identified in the ancient rhetorical manuals. Hermagoras distinguished between two kinds of issues or *stases*, which in modern terms could be called *general issues* and *particular issues*. A *general issue*, called in ancient times a *thesis* or *indefinite question*, is a controversy that does not involve definite individuals (Kennedy, 1963, p. 305), like "Should one participate in public life?" or "Should one marry?" A *particular issue*, called in ancient times a *hypothesis* or *definite question*, is a specific controversy about a named person and a particular occasion (Kennedy, 1963, p. 305), like "Should Cato marry?" or "Did Orestes murder his mother?" Hermagoras assigned general issues (theses) as exercises for students of rhetoric, according to Kennedy (p. 305).

Quintilian, in the *Institutio Oratoria* (III. 5. 5-8) gives a clear outline of the terminology used in the ancient world to distinguish between general and particular issues (Butler, 1920, vol. I, pp. 399-400):

It is also agreed that questions are either *definite* or *indefinite*. *Indefinite* questions are those which may be maintained or impugned without reference to persons, time or place and the like. The Greeks call them *theses*, Cicero *propositions*, others *general questions relating to civil life*, others again *questions suited for philosophical discussion*, while Athenaeus calls them *parts of a cause*. Cicero distinguishes two kinds, the one concerned with *knowledge*, the other with *action*. Thus "Is the world governed by providence?" is a question of knowledge, while "Should we enter politics?" is a question of action. The first involves three questions, whether a thing is, what it is, and of what nature: for all these things may be unknown: the second involves two, how to obtain power and how to use it. *Definite* questions involve facts, persons, time and the like. The Greeks call them *hypotheses*, while we call them *causes*. In these the whole question turns on persons and facts. An *indefinite* question is always the more comprehensive, since it is from the *indefinite* question that the *definite* is derived. I will illustrate what I mean by an example.

The question "Should a man marry?" is *indefinite*; the question "Should Cato marry?" is *definite*, and consequently may be regarded as a subject for a *deliberative* theme.

Quintilian added that there were differences of opinions on how to distinguish between definite and indefinite propositions and how to label the distinction: some called indefinite questions *general questions*, and then, Quintilian wrote (III. 5. 9), we should have to call definite questions *special questions*.

These remarks of Quintilian are highly informative in giving us insight into the nature of relevance and how it can fail in argumentation. Not only must an argument or assertion be related to the issue of a dispute, but it must be related to it in a certain way. If the issue is a general one, and the argument or assertion in question is a concrete or particular one, even though the two propositions are topically relevant to each other, they may not be materially relevant. This failure of material relevance typically occurs, in the kind of case we have considered, where the issue is a highly particular one and the argument interjected into the discussion of that issue is highly general. Unless some intervening chain of argumentation can link one to the other, the general assertion or argument is judged to be materially irrelevant to the issue that is supposed to be discussed in the case.

### 3. THE METHOD OF ARGUMENT EXTRAPOLATION

To determine dialectical relevance of an argument in a given case, what is required, ideally, is to trace the argument back, through a connected sequence of arguments, to the issue of the dialogue. The basic idea is that any argument at any particular point in a dialogue, if it is a relevant argument, is connected to prior arguments in the dialogue, so that the whole chain of argumentation, if traced back to its origin, will lead back to the issue of the dialogue. Here we are thinking primarily of an argument used during the argumentation stage of a dialogue. Whether the argument is relevant at that stage depends on the prior arguments used during that stage and how they, as a chain of reasoning, relate to the issue posed in the confrontation stage of the dialogue. Ideally, if an argument really is relevant in a dialogue, it will be connected to the issue of the dialogue by a chain of argumentation. But in reality, there may be a big gap to be filled between the argumentation in a given case and the ultimate thesis or goal at which argumentation is supposed to finally arrive. What has to be done is to try to chain the argumentation forward to see if it could really be extended to reach its supposed ultimate point. What method of searching could be used to make such a judgment?

In many of the cases dealt with in previous chapters, the context of dialogue is that of a critical discussion or persuasion dialogue on a specific

issue. The first task, after determining what the type of dialogue is supposed to be, is to try to figure out what the issue is in that case, that is, what pair of propositions represents the conflict of opinions in the case. Any argument, or other move used in the case, needs to be judged as relevant or not insofar as the given sequence of argumentation that it is part of can be chained forward so that one or the other of this pair of propositions is the conclusion proved at the last point in that sequence of argumentation. What Ashley and Aleven (1992) call the “factor” of a case is comparable to the forward chaining of the probative function in a dialogue toward the conclusion to be proved. More precisely, the factor in a case is the strongest line of argumentation that can be singled out from all that were used in the case, and was the most powerful in its bearing on the problem or issue of the case. Of course, in many of these cases, the argument is at a mid-point, or just beginning, so it may be hard to judge whether it really is relevant or not. An estimate has to be made, by the method of argument extrapolation or the method of profile reconstruction, to try to see where the argument is leading. If it is leading towards the ultimate conclusion to be proved, then it is dialectically relevant. Otherwise, the presumption is that it is irrelevant unless its proponent can show otherwise. Such an estimate is contextual in nature and has to be carried out on the basis of what information has been given in the case. Thus, as indicated in section 10 of this chapter, judgments of irrelevance should, in many cases, not be regarded as final. There is often room for metalevel argumentation about relevance. Both sides try to estimate where the argument is leading.

The method of *argument extrapolation* uses backward and forward chaining of sequences of arguments, from the text of discourse given in the case, to try to match up two lines of argument. This method applies to cases like Copi’s about the horribleness of murder and that of the senator declaring that all people deserve decent housing. In both these cases, the problem is to try to match up the highly abstract premise or premises put forward by the proponent, with the highly particular thesis he is supposedly set to prove in the dialogue. According to the new pragmatic theory, what the critic needs to do to evaluate this type of case is to extrapolate sequences of argumentation forward from the given premises, to try to meet up with the conclusion that is supposed to be proved. The question is where the argument is going. Or alternatively, one can start at the proposition that is the supposed conclusion and then chain backward to try to see how the line of argument could get there, given the text and context of dialogue in the case. This combination of backward and forward chaining of inferences applies to the reasoning that is used, or could be used, in a given case.

Judging relevance of argumentation in a retrospective way is similar to what is called plan recognition in AI. Both presume a previous forward chaining. According to Carberry (1990, p. 17), plan recognition in AI is the inverse of planning. In planning, an agent tries to formulate a sequence of

actions that will lead to a goal. In plan recognition, "an agent attempts to reconstruct from the available evidence a plan that was previously constructed by another agent." She gave the example (p. 17) of a motorist who sees an empty car with a missing tire parked on the highway. Further down the road, she sees a man rolling a tire, carrying a baby, and leading three small children. What conclusion would she draw? She would likely draw the plausible conclusion that the stranded car belonged to the man, that he was taking the tire to be fixed so that he could continue on his way, and that the children were following them because the motorist was afraid to leave them alone in the car. In such a case, the motorist engaged in plan recognition, because she inferred a plan that she assumed the man was trying to carry out.

It might seem strange at first to think that techniques of planning used in AI could be applied to the analysis of relevance and irrelevance of argumentation in natural language discourse. But problem solving, and also planning as a technique, are known to be applicable to natural-language problems as well as to physical problems. For example, "participating in a conversation and producing an utterance have been viewed as problems in plan construction where the problem is to create an utterance that would satisfy goals involving the transmission of certain contents or intentions" (Wilensky, 1983, p. 9). Thus, many of the techniques of plan recognition used in AI are comparable to methods needed to judge relevance or irrelevance of argumentation.

A chain of argumentation is composed of a sequence of connected subarguments where the conclusion of one subargument reappears as a premise in a next subargument. In the method of argument extrapolation, such a chain is modeled by an argument diagram of the sort widely used already in informal logic.<sup>7</sup> According to the technique as outlined in chapter 5, a sequence of connected subarguments can be represented by an argument diagram in the form of a directed graph. The propositions (premises and conclusions) are points (vertices) of the graph, and the steps of inference are the arrows (edges) of the graph. Ideally then, the whole chain of argumentation in a given case of argument can be modeled as a directed graph where points are joined by lines that indicate the structure of the argument.<sup>8</sup> The new software called *Araucaria* was recommended in chapter 5 as an attractive method of partially automating the process of diagramming.

What general techniques are used to piece together a chain of argumentation when applying the method of argument extrapolation to a case? The first thing to notice is that the type of dialogue will tend to determine what kinds of arguments are used. For example, in a context of deliberation, chaining together of practical inferences in a sequence of practical reasoning is the

---

<sup>7</sup> See, for example, Ennis (1996, pp. 37-55). Other sources on argumentation diagramming were also cited in chapter 5.

<sup>8</sup> Walton and Batten (1984).



method. In the context of a critical discussion, chaining together of *modus ponens* steps of inference tends to be the best general method. However, chains of argumentation used in a case need not be uniform: they need not always use the same forms of inference at each step in the chain. Many different argumentation schemes (forms of inference) of the kind described in Kienpointner (1992) and in Walton (*Arg. Schemes*, 1996) can be used. For example, argument from analogy might be used at one step in a sequence of reasoning and then *modus ponens*, in the form of a deductively valid inference, at the next step. *Araucaria* is equipped with a set of argumentation schemes, and the user can add new schemes as needed.

But *Araucaria* is only meant to diagram a given argument. How could it be extended or modified so it could be used to assist with judging relevance in a given argument? This problem has not been solved by the addition of new software at this point. The previous chapters suggest that what is needed is a machine that can extend a given argument diagram toward the end point, or the ultimate conclusion to be proved. The type of machine needed to carry out such argument extrapolation in a given case could be called the *argument projector*. The argument projector takes the textual and contextual evidence in the given case as material to start from, this being called the *evidential base*. The base includes several things, but two of them are centrally important. One is a given local argument, made up of a conclusion and one or more premises. Conclusion and premise indicators in the given text of discourse provide evidence as to which statement is the conclusion and which statements are premises. This argument is the start point. The other important thing is the ultimate conclusion that is supposed to be proved in the dialogue. This statement provides the end point at which the local argument at the start point is supposed to be aimed. The projector is the device used to make the argument extrapolation from the start point to the end point. It does this by chaining the start point forward to see if the chain of argumentation that is produced will, in fact, arrive at the end point as the last conclusion in the chain.

How does the projector carry out this calculation of the trajectory of the given local argument once it has been determined what the start point and the end point are? It uses data from the text and context of dialogue. It fills in the missing premises in the local argument. It does this by using argumentation schemes and by judging what the audience accepts as “common knowledge” or as plausible. It keeps trying to apply these argumentation schemes, as more and more arguments are built onto the starting local argument. Existing arguments that were already stated in the text of discourse are also patched into the chain where they can be used to move the line of argument forward. As a lengthy chain of arguments from the start point to the end point is filled in, the whole sequence takes the form of a directed graph, represented by an argument diagram. Once such an argument diagram has been produced, the argument projector has done its job.

Producing the argument diagram is only part of the task of determining whether the argument in the given case is relevant or not. The other part is judging probative weight. For example, in case 1.3, it is possible to construct a line of argumentation from the start statement, 'Murder is a horrible crime', to the end statement 'The defendant is guilty of murder'. However, this line of argumentation is not very plausible. The premises and argumentation links in it, when examined carefully, can be seen to be very weak. The chain of argumentation is based on an emotional association that is psychologically persuasive but logically weak. The argument projector can be used to fill in the missing parts needed to take a chain of argumentation from the start point to the end point. Thus, the argument in case 1.3 could be relevant. But once an evaluator looks over this chain, it can be seen that the argumentation has weak links. It is plausible that murder is a horrible crime, and it may even be plausible that the defendant looks like a horrible person, but how plausible is it that he must have committed the murder he is accused of because of a link seen between horrible-appearing persons and horrible crimes? There is a chain of argumentation there that can connect up the two things, but it is very weak at best. In a criminal trial, strong evidence is needed that shows beyond reasonable doubt that the defendant committed the crime he is accused of. Mere suspicion, or suspicious appearance, is not supposed to be good enough. In fact, the mere suspicion that the defendant looks like he could be guilty is highly misleading as evidence, even though juries naturally enough tend to take such observations and suspicions into account.

To sum up, there are two parts to a judgment of relevance. The first part is the use of the argument projector to produce an argument going from the start point to the end point. If such an argument extrapolation cannot be produced, then the given argument is not relevant. But if the extrapolation can be produced, the next part is to examine the argument diagram and look for weak points. Are there individual statements (premises or conclusions) in the diagram that are not plausible? Are there individual arguments in the chain that are weak? Either kind of defect is an indicator that the argument is not relevant. The more flaws of either kind that are found in the chain, the more evidence there is indicating that the argument is not relevant. If all the individual statements are plausible and all the arguments in the chain are strong, this kind of evidence shows that the argument at the start point is relevant.

The evaluation of relevance in a particular case, then, depends on the use of argument diagramming to reconstruct the sequence of reasoning used in that case. This method will be applied to legal argumentation in chapter 8, so there is no need to go into details here. But generally speaking, such an argument analysis should proceed on a case-to-case basis, using the evidence furnished by the text and context of discourse of the case under analysis. An important part of the use of this method is the determination of premises (and conclusions) that were not explicitly stated but that play an essential part in a sequence of

argumentation. Traditionally, arguments containing such nonexplicit premises (or conclusions, in some cases) are called *enthymemes*, although the original meaning of the term *enthymema* was something different.<sup>9</sup> Such nonexplicit propositions must be specially designated in an argument analysis as different from assertions that have been explicitly stated in the text of discourse. They should be treated as only presumptions, that is, as assumptions needed to make sense of an argument as a contribution to a dialogue. They can sometimes be identified in an argument diagram with the aid of an argumentation scheme.

To show how a dialectical analysis using argumentation schemes can help to identify nonexplicit premises in an argument framed in a natural language, consider the following variant on an example from (Hurley, 2000, p. 289):

*The Corporate Income Tax Argument*

The corporate income tax should be discontinued because it encourages waste and high prices.

To exhibit the structure of the argument, an implicit premise can be added, 'Encouraging waste and high prices are bad consequences'. Finally, there is another implicit assumption that can be expressed as a conditional: If a practice has bad consequences, then other things being equal, it should be discontinued. This conditional suggests an inference transition that resembles the argumentation scheme for argument from negative consequences (Walton, 1996, p. 76). This form of argument could be expressed by using the following version of this argumentation scheme:

*Scheme for Argument from Negative Consequences*

If a practice has bad consequences, it should be discontinued.

This practice has bad consequences.

Therefore, this practice should be discontinued.

Given the missing premise and the argumentation scheme for argument from negative consequences, the structure of the original argument can now be displayed more explicitly.

---

<sup>9</sup> See Joseph (1916, pp. 350-351).

*Reconstruction of the Corporate Income Tax Argument*

**Explicit Premise:** The corporate income tax encourages waste and high prices.

**Missing Premise:** Encouraging waste and high prices are bad consequences.

**Interim Conclusion:** The corporate income tax has bad consequences.

Now the interim conclusion can be plugged into the minor premise of this argumentation scheme as a practice that fits that premise. The major premise of the argumentation scheme can be put forward as another implicit assumption. The minor and major premise together then generate the final conclusion of the argument.

**Final Conclusion:** The corporate income tax should be discontinued.

In analyzing an example like the corporate tax argument, the missing premise needs to be identified. In the past, the logic textbooks have only been able to appeal to common sense to make a judgment of what the missing premise should be. If the argument is of the deductively valid type, then of course a deductive system, like the procedure for determining validity in syllogistic logic, has been shown by the logic textbooks to be partly useful. The formal system alone, however, does not indicate indisputably what the missing premise is although it often helps to give some guidance or direction on how to look for a candidate. The problem is that many common examples do not fit the deductive model.

*Araucaria* can be used to display an argument diagram that represents the corporate income tax argument based on what is given in the text of discourse. You have to mark the premises and conclusions by highlighting them in the text document, you have to add in the missing premise, and you have to draw arrows indicating which set of premises leads to which conclusions. *Araucaria* uses this input to construct the argument diagram. The diagram displays how the argument chains forward from the initial pair of premises to the interim conclusion, and from there to the final conclusion, as shown in figure 6.1. But *Araucaria* can also display further information about how an argument was derived using an argumentation scheme. *Araucaria* already contains the argumentation scheme for argument from consequences. It can brought up from the repository of argumentation schemes and then applied to the diagram to indicate which conclusion was derived from which premises using that scheme. In figure 6.1, the line of argument indicated by arrows joining the darkened

boxes, along with the label “argument from consequences,” provides this information.

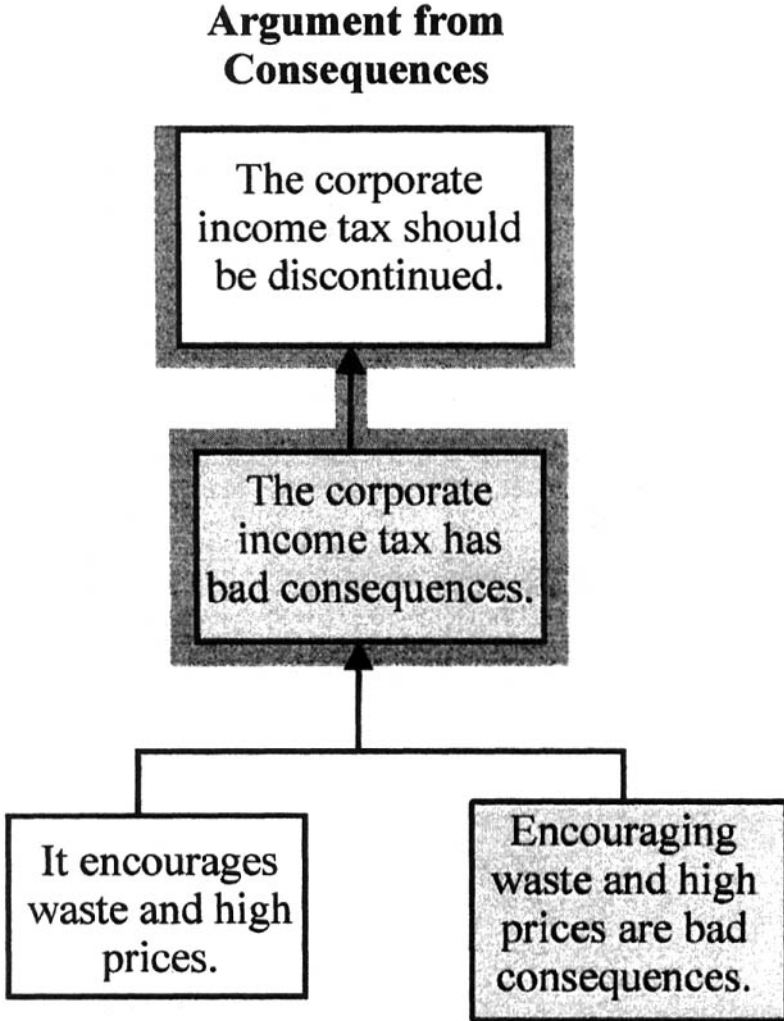

**Figure 6.1:** Araucaria Diagram of the Corporate Income Tax Case

It is a strong point of *Araucaria* as a method of argument diagramming that it includes a database for argumentation schemes representing many common forms of argument that are neither deductive nor inductive. When

using *Araucaria* to construct an argument diagram for an argument like the corporate income tax argument, you can bring up the list of argumentation schemes from the database and then apply it to the argument you are diagramming. The software system does not identify the missing premise by itself, but it does help the user to find it by allowing her to select the appropriate scheme and to mark it on the diagram as the structure linking the premises to the conclusion.

The additional dialectical machinery needed for finding missing assumptions in the reconstruction of a sequence of argumentation involves the filling in of so-called dark-side commitments. Dialectical structures useful for this purpose have already been set out in Walton and Krabbe (1995). *Dark-side commitments* are commitments that are presumptions representing nonexplicit premises, postulated on a basis of implicature. For all these reasons, the best evaluation one might be able to hope for in a given case is a conditional evaluation, that is, a judgment that such-and-such an argument is relevant as far as we can tell from the given text and context of dialogue in the case. The assumption is that if certain intervening steps in the chain of argumentation are postulated, then the argument is relevant in that case. Clearly then, in assessing relevance in any particular case, much will inevitably depend on how much information, both textual and contextual, is given in that case.

Quintilian's analysis of the horribleness of murder type of case shows that in some cases there can be two distinctly different lines of argument leading by different routes to the issue. In such cases, the method of argument extrapolation needs to be used to describe, in as detailed a way as possible, these two chains of reasoning. In this type of case, the method of argument extrapolation requires a comparative analysis of two chains of reasoning. The general method is to make an argument diagram showing the chaining forward of the reasoning exhibited in the given case. Then the argument projector needs to be applied to this information about the existing argumentation in the case. Can the argumentation be extrapolated forward so that it reaches the point that is supposed to be proved? If so, the argument is relevant. If not, then it has been shown not to be relevant, as far as can be determined from the information given in the case.

The method of argument extrapolation is a fairly simple method of determining relevance, and it is clear that it has several limitations. One practical limitation is that the structure of argumentation connecting the given argument to the original issue of a dialogue could be dialectically complex, requiring a dialectical analysis based on what type of dialogue is involved. To conduct this kind of analysis in every case would be beyond the method of argument extrapolation, especially where the case involved dialectical shifts and an analysis for relevance would require many dialectical assumptions and

conditions.<sup>10</sup> For example, it is clear that the analysis of cases of argumentation involving enthymemes depends on a Gricean pragmatic assumption like the (*CP*). That is, that an argument is provisionally reconstructed as having such-and-such a proposition as an unstated part on the ground that it can be inferred by Gricean implicature. The implicature is inserted on the assumption that the proponent of the argument in question is following the Gricean maxims and making the kinds of contributions required at the particular stage of the dialogue the participants have supposedly reached. Thus, much of the evidence needed to construct an argument diagram is dialectical in nature, in the sense that it comes from the context of dialogue, and indicates how the argument is (ideally) being used to contribute to the goal of a conversation. To deal with such cases, other techniques in addition to that of argument extrapolation must be brought to bear.

#### 4. MODELING SHIFTS, EMBEDDINGS, AND FALLACIES

The problem with the method of argument extrapolation is that it is limited to cases in which there is only one type of dialogue involved and the goal of that dialogue is known. But many of the problematic cases where relevance needs to be determined, as shown in the previous chapter, are ones where a dialectical shift has occurred. The central problem of relevance in these cases is whether one dialogue is functionally embedded in the other or whether the shift was illicit. This kind of problem cannot be solved by the method of argument extrapolation alone. It is exactly this kind of problem arising from a dialectical shift, or what appears to be a shift, that is central to the analysis and evaluation of so many of the informal fallacies.

As noted in the previous chapter, apparent relevance is frequently the key to understanding how fallacies of relevance function as plausible moves that can realistically be used to deceive participants in an argument. For example, in the case of the *ad baculum* fallacy, a threat used as an argument may derive its plausibility from a dialectical shift. Generally, threats are not relevant in a critical discussion. If used in a clear case of a critical discussion, a threat would appear very much out of place.

*Case 6.3:* In a philosophy seminar where the free will issue is being discussed, one participant makes a threat to beat up one of the other participants, if he does not accept the first participant's viewpoint on the issue.

This threat would be regarded as highly inappropriate, perhaps even ridiculously so. Its irrelevance to the critical discussion would be transparently evident to

---

<sup>10</sup> Krabbe (1992, p. 278).

anyone. Not only would the threat be unethical, or possibly even illegal, but it would be evident that it is not the right sort of argument to provide evidence for one's viewpoint.

The question is how such an *ad baculum* argument could ever be a fallacy, a deceptive argument that would fool someone. The best explanation of how this kind of fallacy works relates to the shift from the one type of dialogue to the other. The threat was not appropriate as an argument in the critical discussion. It had no real function as a persuasive argument. But perhaps because negotiation could also have been partly involved in the conversation in a given case—or if it would be difficult to exclude the possibility of some kind of negotiation being involved in that case, say if the conversation involved a legal or political argument—the *ad baculum* argument based on a threat might not seem so completely out of place. The mixed dialogue, or the possibility of a shift from the one type of dialogue to the other, would give the argument some appearance of appropriateness.

In this kind of case, where there is a shift or the possibility of a shift, from one type of dialogue to another, a critic of an argument must ask the question, What was the original type of dialogue the participants were supposed to be engaged in? The evaluation of the relevance of the argument should be based on this key question. But in evaluating relevance, much depends on whether the shift was a licit or illicit one. Let's say in a particular case that the conversation was supposed to be a critical discussion to resolve a conflict of opinions by rational means, but that one participant started to negotiate, by offering incentives to the other to change his viewpoint or even by issuing threats to him. If the argument on the original issue was supposed to be a critical discussion, and if the other participant never agreed to shift to a negotiation dialogue and continued to argue in the belief that a critical discussion was still underway, then the shift to negotiation would be illicit. It would then be correct to evaluate the *ad baculum* argument put forward by the first party as irrelevant. What this evaluation presumes is that threats have no proper place in a sequence of argumentation aimed at resolving the conflict of opinions in the original critical discussion. From this evaluative viewpoint, the threat is irrelevant. And if it was found to be irrelevant, that judgment could be part of the evidence behind the claim it is fallacious.

It may also be worthwhile noting here that the making of a threat by one party to another generally is relevant if the conversation exchange is viewed as a deliberation. For it may be very prudent for the party to whom the threat was addressed to recognize the speech act as a threat and to deliberate carefully on a course of action that takes the threat into account. In some cases, it may even be prudent to comply with the demand made by the threat. At the same time, it may also be quite correct to evaluate the threat by judging it to be a poor argument from the viewpoint of a critical discussion of the issue between the two parties.



From this viewpoint, the threat could rightly be judged to be irrelevant and even fallacious.

In another kind of case, however, the shift from the one type of dialogue to the other could be licit, and could even be a functional embedding in which one dialogue helps the other to realize its goal. Consider an example where two parties are having a philosophical discussion on the issue of whether abortion should be generally seen as morally permissible.

**Case 6.4:** Bob and Helen are having a critical discussion on the abortion issue, and their argument depends on the question of when the fetus could live on its own, if delivered by Caesarean. They both turn to physician Ted, who gives them a medical opinion on this question, based on what he knows about the subject as a doctor.

In this case, the dialogue started out as a critical discussion on the issue of whether abortion should be generally permitted or not. Then it shifted to an information-seeking type of dialogue, as both Bob and Helen consulted Ted, who was a convenient source of expert information. It could well be, in this kind of case, that the information-seeking interlude is helpful to the critical discussion by making it better informed. As long as both participants agreed to use Ted as an authoritative source on the medical facts they wanted to find out about, the shift back to the critical discussion could move it closer toward resolution.

In a case like this one, the argumentation put forward by Ted, in the form of presenting medical information to Bob and Helen, was relevant. Or let's say, anyway, that Ted provided relevant information and did not attempt otherwise to influence their opinions. Even though there was a shift from the one type of dialogue to the other, relevance was preserved over the shift. The moves made in the information-giving interlude could be relevant provided they fitted into the longer sequence of argumentation in the critical discussion in a constructive and helpful way.

Generally speaking then, a move or sequence of argumentation in one type of dialogue can, in some cases, also continue to be relevant after a shift is made to another type of dialogue. In such a case, relevance is preserved over the dialectical shift. However, a preservation of relevance over a shift is by no means always the case. It could be an illicit shift, and the moves made in the intervening dialogue could actually interfere with the realization of the goal of the type of dialogue that was the original conversation exchange. In this contrasting type of case, relevance is not preserved over the shift. It is exactly this latter type of case that is characteristically associated with fallacies of irrelevance, like *ignoratio elenchi* and the other fallacies of relevance cited in chapter 3.

What is needed is evidently some way of formally modeling the sequence of dialogue moves in a case where during the course of a sequence of argumentation, there has been a dialectical shift, and one dialogue has been functionally embedded in the other. Or at least, what is needed is a way of presenting the formal structure of such a sequence of dialogue so that a determination can be made on whether a functional embedding exists or not.

One type of embedding that has been formalized is the embedding of an RPD dialogue into a PPD dialogue (Walton and Krabbe, 1995, pp. 163-166). The PPD, or permissive persuasion dialogue, starts out—a critical discussion on medical ethics—in the case modeled in Walton and Krabbe (1995), but then there is a shift to a rigorous persuasion dialogue (RPD). In the permissive persuasion dialogue, the rules allow considerable flexibility, whereas, but in the rigorous persuasion dialogue, they are tightly formulated, limiting the moves that can be made. In the example studied, the reason for the shift from PPD to RPD is that the embedded RPD dialogue is more strict, and its advent introduces greater precision in clarifying points of interpretation that are posing problems for the productive continuation of the PPD. But this kind of embedding is easier because both dialogues are persuasion dialogues, and so both have the same kind of goal. What about cases where there is a shift from one type of dialogue to an entirely different type? Could any formalization be helpful in modeling the argumentation in this kind of shift?

Another way to formalize argumentation in which there are embeddings of dialogues is that of Reed (1998). Each particular example of a dialogue is represented as a sequence of utterances. A dialogue frame (Reed, 1998, p. 248) is a four-tuple. The type of dialogue,  $t$ , can be that of persuasion, negotiation, inquiry, deliberation, or information-seeking. The topic,  $\tau$ , is the issue or conflict that is supposed to be resolved or settled by the dialogue. The two participants in a dialogue are represented by  $x_0$  and  $y_0$ . Each utterance made at each move of the dialogue is numbered at the left of the table representing the sequence of all the moves in the dialogue. So  $u^i x_i \rightarrow y_i$  refers to the  $i$ th utterance in a dialogue between two participants. Every utterance has the form of a pair in which the first element is a statement and the second represents the supports for that statement. Using this notation, a dialogue frame,  $D$ , is defined as follows (p. 248):

$$F = \langle \langle t, \Delta \rangle \in D, \tau \in \Delta, (u^0 x_0 \rightarrow y_0, \dots, u^n x_n \rightarrow y_n) \rangle$$

Using this notation, a dialogue can be represented as a sequence of moves in which the participants take turns making utterances of various kinds that can be recognized as appropriate for a given type of dialogue. For example, in a negotiation dialogue, proposals (offers) can be made by one party and then accepted by the other. In a deliberation dialogue, a proposal can be made by one

party to go ahead with some designated course of action, and then the other party can accept that proposal.

Reed offers a number of interesting examples, but a very simple one will serve to illustrate how the formalization represents the sequence of moves in a dialogue. In this case (Reed, 1998), one agent has the goal of hanging a picture, and has a hammer. This agent knows that the other agent has a nail, and that having a hammer, picture and nail enables picture hanging. In Reed's notation, one agent can give supporting reasons to another for accepting a proposition or course of action, and these reasons or premises can be represented in the dialogue formalization by labels like  $f1$ ,  $f2$ ,  $r1$ ,  $r2$ , and so forth. The dialogue in the picture hanging case can then be represented in Reed's notation as follows.

$$\begin{aligned}
 u^0_{a \rightarrow b} &: \{ \{ \text{propose}(\text{deliberate}, (\text{can}(a, \text{hang...picture}), (0))), (0) \}, (0) \} \\
 u^1_{b \rightarrow a} &: \{ \{ \text{accept}(\text{deliberate}, (\{ \text{can}(a, \text{hang...picture}), (0) \})), (0) \}, (0) \} \\
 u^2_{a \rightarrow b} &: \{ \{ \text{propose}(\{ \text{have}(a, \text{nail}) \Delta \text{can}(a, \text{hang...picture}), (0) \}), \} \\
 &\quad (f1, f2, f3, f4, r5) \} \\
 u^3_{b \rightarrow a} &: \{ \{ \text{accept}(\{ \text{have}(a, \text{nail}) \Delta \text{can}(\text{hang...picture}), (0) \}), \} \\
 &\quad (f1, f2, f3, f4, r5) \}
 \end{aligned}$$

One of the most interesting features of this way of modeling the interaction of two arguers is that the types of dialogue active at each move can be represented. For example, at the first two moves, the notation makes it evident that the participants are engaging in a deliberation type of dialogue. At the third and fourth moves, although in this case it is not obvious from the formalization, the participants are engaging in a negotiation dialogue. First, they deliberate on whether and how to hang the picture. Then, in order to carry out the goal of their deliberation, they negotiate the handing over of the required nail.

Reed's method of dialogue frames is helpful because it exhibits some features of the embedding in useful way. The first two moves in his modeling of the picture hanging dialogue are shown to be part of a deliberation. Presumably, the third and fourth are part of a negotiation dialogue. So the shift is indicated. Also, Reed's modeling of the dialogue shows that certain propositions are contained in all four moves of the dialogue. What we see here, then, is the beginnings of a method that could be used to analyze the structure of cases in which a dialectical shift has occurred or may have occurred. But how could this formal apparatus for representing the sequence of moves in a dialogue be applied to specific cases of the kind so typically encountered where dialectical relevance or irrelevance is a problem? The best way to answer this question is to examine one such problematic case.

## 5. ANALYSIS OF THE CURRENCY CONVERSION CASE

A detailed method to model argumentation in a case of functional embedding can be obtained by going back to the currency conversion case studied in the previous chapter. This case is typical of many cases of appeal to expert opinion in a persuasion dialogue. During the persuasion dialogue on European currency conversion, premise 1 seemed to appear out of nowhere. But once it was challenged, it became evident that it was based on expert opinion. The introduction of expert opinion as a source of support for premise 1 immediately signaled the existence of a dialectical shift. Dealing with any challenges to premise 1, or trying to give reasons to support it, immediately transfers the conversation to a different type of dialogue. Now one is dealing with a conversation with an expert. Arguments brought forward in that framework have a special status and need to be dealt with differently than in the prior persuasion dialogue. In the persuasion dialogue, the arguers were equals, in the sense that the pronouncements of one had no privileged status over those of the other. In the expert consultation dialogue, the pronouncements of the expert have a special status as a type of evidence. They can be challenged by the other party, but the process of mounting and judging challenges is different. The interlocutor is (presumably) not an expert in the field in question, so he must accept what the expert says as a kind of information. He can question the expert's opinion, but the way of questioning it needs to be seen as different from the way of questioning an opinion cited in a persuasion dialogue.

The shift occurs in this case when premise 1 is challenged. At this point, there are various possibilities. The user of 1 as a premise in her argumentation in the persuasion dialogue could simply say, "An expert economist has said so" and leave it at that. The other party in the persuasion dialogue could challenge the appeal to expert opinion by asking a critical question like, "Is she really an expert?". That could be one type of shift. But suppose the economist cited as an expert is present and able to defend her opinion verbally. In that kind of case, there is not only a dialectical shift but also an entirely different subdialogue in which a third party (the economist) actually becomes a proponent in a dialogue with the party who has challenged her view. This development is an even more dramatic kind of dialectical shift.

Let's consider this second kind of case, as sketched in Figure 5.2. The economist brings in two linked arguments as independent lines of support for 1, as indicated in figure 5.2. Now 1 is the common element between the two dialogues. 1 is the conclusion in an argument, represented as everything above and including 1, that takes place in an information-seeking dialogue. But at the same time, 1 also functions as a premise in a chain of argumentation in a persuasion dialogue that leads to conclusion 4. This part of the argumentation is represented by 1 and everything below 1 in figure 5.2. The functional

embedding occurs because 1 is the common element in both dialogues, which holds the whole sequence of argumentation together as a unit.

The way to model the functional embedding formally in this case is to draw a horizontal line through figure 5.2 that runs right through 1. Then above the line, mark "Information-seeking Dialogue" and below the line marked "Persuasion Dialogue." Then it will be clear from the diagram how the one dialogue has been embedded in the other. But the shift should also be indicated on the formal modeling of the sequence of dialogue. Let's take the example of the picture-hanging dialogue as formalized by Reed earlier in this chapter. In utilizing this kind of formalization of the European economy case, we will have a sequence of dialogue moves, each written as a line below the prior move. The participants will take turns. So the zero move will be by one party, the first by the other party, and so on, with turn-taking at each move. The content of each move will be indicated in the usual way, for example, by the method of notation that Reed proposes. A feature we will now make mandatory is that the type of dialogue will be indicated somehow for each move. This could be noted in the formal notation for the move itself, as Reed has done, at least for the first two moves of the picture-hanging dialogue. Or it could be noted in the beginning and ending moves of a long sequence if there is a long sequence of moves in the same type of dialogue. For example, suppose that one party in a persuasion dialogue asserts propositions as part of her argument, and the other, at the next move, asks 'Why A?'. Then the first party replies, "Because an expert said so." At this last move, a shift has occurred. The other party may just accept the appeal to expert opinion. Then the shift is just a one-line shift that is not very significant. However, if the other party starts to question the basis of the expert opinion, a lengthy subdialogue could occur.

What will now be unique about the new method proposed is that there will be overlaps, that is, cases in which a single move, like an assertion, is a common element between the two types of dialogue. For example, in the European economy case, proposition 1 is common to both dialogues. The formal method useful to model such cases is to associate the representation of the sequence of dialogue with an argument diagram that exhibits the connected chain of argumentation running through a sequence of moves in a given case. What will happen is that such chains of argumentation will be short in some cases, long in others, and they will generally run through some subset of the whole set of dialogue moves in a case. The reason the diagram is useful, taken along with the dialogue sequence, is that it can model the precise way in which one dialogue is functionally embedded in the other. We can look over the whole argument and see not only the shifts but the particular propositions that are the common elements joining the sequences of argumentation together precisely at each shift. By this method, not only can the shift be modeled but also the functional embedding underlying it.

What tends to happen in many cases of argumentation which are interesting and problematic from a point of view of critical thinking, is the following scenario. A proposition is asserted by one side in a dialogue—say, a persuasion dialogue—and then challenged by the other party. The reply to the challenge then takes the form, “An expert said so.” The challenger will then ask one or more of the critical questions appropriate for questioning an appeal to expert opinion, like “Is she really an expert?” or “What are her qualifications ?” The first party may then supply answers to the questions. In a case like this, there has been a shift to an information-seeking subdialogue that is functionally embedded in the original dialogue. Part of the information-seeking dialogue is a testing of the purported information to see if it is genuine information. Information-seeking dialogue of the kind characteristic of appeal to expert opinion argumentation has a so-called *peirastic* aspect, meaning that it has the purpose of not only collecting information but also testing that information to verify whether it is reliable or not.

What typically happens in such cases is that there exists an information-seeking dialogue functionally embedded within the larger persuasion dialogue. First there is a shift from the persuasion dialogue to the *peirastic* interval of expert opinion presentation and examination. Then, after the closure of the *peirastic* interval, there is a shift back to the original persuasion dialogue. The actual participants are the same in both dialogues. Hence, it can be easy for the superficial observer to overlook the shift and thereby fail to realize its importance when it comes to evaluating the argumentation. From a viewpoint of formal modeling of argumentation, what would be most valuable would be to supplement the method of argument diagramming, as used in such cases, by indicating the functional embedding on the argument diagram. The method of doing this is simple. It is to draw a horizontal line through the diagram at the point where the subdialogue began and another line at the point where the subdialogue ended. The type of dialogue represented by the subinterval needs to be marked on the argument diagram.

To fully grasp how a functional embedding works in a given case, more than an argument diagram is required. The argument diagram needs to be associated with a sequence of dialogue. For example, in the currency conversion case, let's say the dialogue proceeded as follows.:

*Wilma:* Why do you think conversion to a common currency is a good outcome?

*Bruce:* Because conversion to a common currency improved the economies of all participating countries in all prior cases where it has occurred. And of course, improving the economies of all the participating countries is a good outcome. So that is why I think that conversion to a common currency is a good outcome.

- Wilma:** You claim that conversion to a common currency has always improved the economies of all participating countries in the past. That's a broad claim. How could you prove that?
- Bruce:** Well, here's an article in the *Journal of Economics* by noted economist Dr. Bucknik, who has shown this thesis to be true using the following arguments (Bruce cites supporting arguments, as quoted from Bucknik's article).

This short bit of dialogue could be represented abstractly as having the following form, using conventions consistent with those of Hamblin (1971) and Walton and Krabbe (1995).

- Move 0:* W: Why 4?  
*Move 1:* B: Because 2 and 3.  
*Move 2:* W: Why 2?  
*Move 3:* B: Because 1.  
*Move 4:* W: Why 1?  
*Move 5:* B: Because 5 and 6, and also 7 and 8.

In this small sequence of dialogue, the dialectical shift occurred at Move 5. It was at that point that the appeal to expert opinion was used as an argument to back up the disputed claim 1. Because the conclusion of the argument is proposition 1, move 4 is also involved in the shift. It is the move that triggered the shift.

A schematic representation of a small subsequence of a larger dialogue, like the one above, is called a profile of dialogue (Krabbe, 1992). A profile of dialogue may be defined (Walton, 1999, p. 53) as "a connected sequence of moves and countermoves in a conversational exchange of a type that is goal-directed and can be represented in a normative model of dialogue". The profile of dialogue is often a useful tool for the analysis and evaluation of argumentation in particular cases because it can be used to display the local exchanges of moves between two parties that are most important for the particular criticism that is the focus of analysis or evaluation. In many cases, using the whole apparatus of the formal model of dialogue, with all its rules and with a lengthy sequence of moves, would be too tedious and may not really be necessary. Instead, using a profile—a short sequence that is a small part of the longer sequence—is much handier, and reveals enough of the structure to show the important features of the dialectical context of the argumentation.

When there has been a dialectical shift, the place where the shift occurred can easily be marked on the profile. Alongside the profile, an argument diagram can also be used to analyze the structure of an important sequence of argumentation that runs through all or part of the profile. These two tools, especially when used together, can give a very good abstract model of a

localized sequence of dialogue argumentation in a given case. When the two are used side by side, and the dialectical shifts are marked on both, a very good analysis can be given, showing how a functional embedding works in a given case. In the end, however, these two tools are not enough by themselves to enable a judgment of whether a shift in the given dialogue truly represents a functional embedding. To make that judgment, there has to be some consideration of the goals of the two types of dialogue involved. The question is whether the advent of the second type of dialogue contributes to the goal of the first. This question is a global one, but it needs to be answered in light of the particular sequence of argumentation in a given case. Here, then, we come back to the argument diagram and the profile of dialogue representing the local moves made in a given case. Thus, there are three kinds of evidence that are most vital to analysis of functional embeddings: the goals of the two types of dialogue involved, the profile of dialogue, and the argument diagram.

Before going on to outline the way these three kinds of evidence need to be brought together in evaluating a case where relevance is a problem, it is useful to outline the general features of the new method of profiles of dialogue. Then, it can be shown how this new method can be used along with the method of argument extrapolation. The two methods can then be used in conjunction with each other as needed in a given case.

## **6. THE METHOD OF PROFILE RECONSTRUCTION**

To accommodate the need to evaluate units of speech other than argument that play roles in argumentation in a dialogue, it is useful to broaden the applicability theory of relevance by introducing another technique for evaluating relevance in a given case. This technique is applicable to questions, replies to questions, and other parts of a conversation over and above arguments. It is best applied to cases where information has been given about what moves preceded or followed the move in question. It is also the most applicable method to judge the relevance of questions or other units of speech than arguments. However, it is the best method to apply to arguments as well if information is known about the sequence of prior exchanges in the dialogue that led up to the presentation of the argument.

What is needed to judge relevance in units of speech that are not arguments is a more generalized procedure that bases the evaluation primarily on a locally connected sequence of various kinds of moves at some particular juncture of a conversation, or on a short series of moves in the dialogue, as reconstructed from the text of discourse in the given case. The useful tool here is the profile of dialogue, a localized connected sequence of moves in a dialogue that is one part (usually a small part) of a longer sequence. Normally the profile would fit into a longer sequence of moves covering the longer argumentation



sequence at a particular stage of dialogue, so that the local argument ( $Q$ , in figure 6.2) has an initial part and a subsequent part.<sup>11</sup>

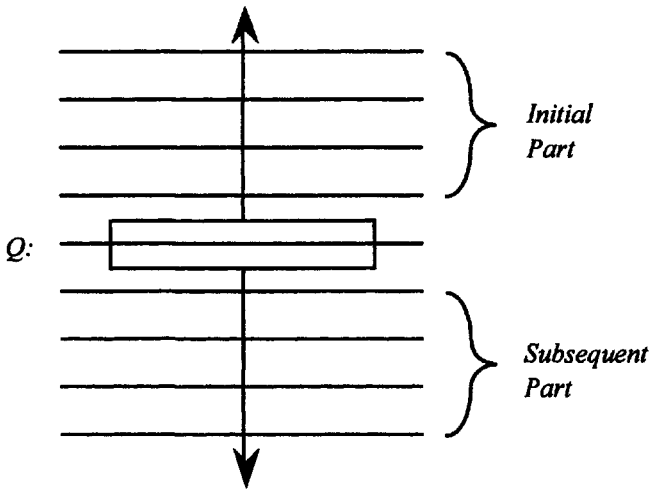

**Figure 6.2:** Profile of Reasonable Dialogue

The profile of dialogue tool was used in Walton (*Quest. Reply*, 1989, pp. 65-71) to analyze complex questions containing presuppositions functioning in an argumentative way in a dialogue designed to attack and entrap a respondent who is obliged to reply. Krabbe (1992, pp. 277-281) also used some cases to show how profiles of dialogue can be employed as a tool to evaluate relevance problems in persuasion dialogue.

The method of *profile reconstruction* works by constructing a profile of dialogue, as characterized generally in figure 6.2, and then filling in its parts, and analyzing its structure, in light of the rules and procedures for the type of dialogue to which the profile applies. This method works best when there is a given sequence of question-reply exchanges in the text of discourse in the case. For example, as in case 6.2, a reply could be judged to be relevant or irrelevant to a question.

The technique of profile reconstruction is a normative development of empirical studies of the use of speech acts in dialogue exchanges in linguistics. For example, Schegloff (1988) applied speech act theory to ordinary

<sup>11</sup> Figure 6.1 is reprinted from Walton (*Quest.-Reply*, 1989, p. 67).

conversational exchanges by studying turn-taking in transcripts of natural language conversations. To understand how one move in a conversation is relevant to another, Schegloff found that you need to know how one speech act is paired by type with another, for example, how a type of reply is appropriate following a certain type of question, or how “repair” is appropriate following a misunderstanding (p. 56). But he also found that to understand such a question-reply pair, a so-called “adjacency pair,” you may also need to understand the presequence of dialogue that led up to it.

Levinson (1981) noted that adjacency pairs in dialogue do not always follow the question-answer stereotype. He presented examples where questions are followed by other questions, by statements of ignorance, by denials of the relevance of the question, and by details of the presuppositions of the question, as illustrated by the following case (p. 107):

- Case 6.5:*    A: What does Joe do for a living?  
                   B:  i) Do you need to know?  
                       ii) Oh this and that.  
                       iii) I’ve no idea.  
                       iv) What’s that got to do with it?  
                       v) He doesn’t.

In studying such cases, Levinson found that it was not just the type of speech act that determined what was or was not an appropriate sequence of dialogue in a natural conversational exchange. But even so, studying adjacency pairs and short localized sequences of dialogue did seem to be a useful tool in situating questions and other speech acts in a coherent sequence of relevant moves in a conversation.

Jacobs and Jackson (1983, p. 60) found the adjacency pair to be a special, limited case of a more general rational structure relating to the cooperative pursuit of social goals. Accordingly, rational agents in a conversation can be expected to develop elaborate strategies to locate and repair sources of misalignment in a conversation. Such general rational structures would explain, for example, how a participant in a conversation would exploit irrelevance, as in the kinds of cases cited by Grice (chapter 1), to collaborate with the other participant by getting a message to him by an implicature. Such communications presuppose general principles of collaborative rationality in a conversation, like Grice’s (*CP*).

Extending these insights to the problem of evaluating normative relevance in cases of the kind addressed by logic, one can see the usefulness of the method of profile reconstruction within a broader conversational context. It is the more accurate of the two methods. But the method of argument extrapolation tends to work better where arguments or parts of arguments (premises or conclusions) are criticized as irrelevant where the example cited is

brief and where little or nothing of the history of the sequence of actual exchanges between the proponent and the respondent is known. In still other cases, the two methods can be combined, as needed. For example, the method of profile reconstruction could be used to situate an argument, part of an argument, a proposition, or a question, in relation to the adjacent moves in the conversational exchange of which it is a part. Then, argument extrapolation could be used to evaluate where that localized exchange could go as a contribution to some line of argument that would help to fulfill the goal of the conversation as a whole. The one method can be used to fill the gaps left by the other.

## 7. OUTLINE OF A COMBINED METHOD

A method of formalization of argumentation that would be useful for modeling cases like those considered above requires several features. First, it requires the profile of dialogue apparatus for representing moves in a dialogue sequentially. Also needing to be indicated is the ordering of the moves and the content of each move as a type of speech act permitted in a given type of dialogue. But second, the method also requires use of the technique of argument diagramming, and the method of argument extrapolation. What is required is, in fact, an integrated technique of argumentation representation in which the argument diagram and extrapolation are mapped onto a profile of dialogue. The argument diagram should not only show all the premises and conclusions in the chained argumentation and the arrows of inference that connect them all together. It should also show the key points at which dialectical shifts occurred. The tableau representing the moves in the dialogue should show not only the contents and the ordering of these moves, in the conventionally accepted way, but also the type of dialogue in which each sequence of moves is supposed to occur. So if there is a shift from one type of dialogue to another, the tableau should indicate exactly where the shift occurred. But even more is required, namely, that if the shift is based on an embedding of one dialogue within another, this factor should be indicated too. Then the embedding can be evaluated as part of the general evaluation of the argument. To evaluate the embedding, the goals of the two types of dialogue need to be considered, so that some account can be given of how the one dialogue supports or does not support the goal. None of this task appears to be technically difficult or to require any methods of argumentation modeling other than those already separately in use. Mainly what is required is a joining together of the dialogue tableau method with the method of argument diagramming so that one can be used in conjunction with the other.

The three components that need to be put together to evaluate any case of argumentation where a functional embedding has occurred are the following: (1)

the global context of dialogue, (2) the profile of dialogue representing the local argument where the shift occurred, and (3) the argument diagram representing the local part of the argumentation around and running through the shift. Component (1) is necessary for the following reasons. To evaluate whether there is a functional embedding, you need to know what the original type of dialogue was. Also, you need to know what the issue or problem of that original dialogue was, so you can judge the relevance of the argumentation in the nested dialogue. Component (2) is necessary because you have to take a close look at the argumentation around the shift. Especially, you have to look at how the moves in this area fit together. Component (3) is necessary because the nested subdialogue may fit in at certain parts of the chain of argumentation in a functional way. For example, information-seeking dialogue may furnish particular premises needed to make a persuasion dialogue more informative.

A fourth component also seems to be important in some of the cases. In the case of the discussion on the European common currency, what made the shift useful was the need to support a certain premise in the argument. In persuasion dialogue generally, there is often a need to support certain premises, and this need can only be met by shifting temporarily to an information-seeking type of dialogue—for example, by using an appeal to expert opinion. In this type of case, the argumentation scheme may be very important. For example, any use of appeal to expert opinion as an argumentation scheme in a persuasion dialogue will require a shift to another type of dialogue in which the appeal to expert opinion is brought forth and possibly questioned. In the picture-hanging case, the goal was for the first party to find some line of action that would facilitate the hanging of the picture. But it became apparent that this deliberation could only be successful with the cooperation of the second party, who could hand the nail to the first. Hence, a shift to negotiation was what was required to make the deliberation successful. In this case, the argumentation in the deliberation dialogue was a chain of practical reasoning, or goal-directed means-end reasoning. To make this chain of reasoning go forward, what was needed was the assumption that the nail could be handed to the first party while he was in a position to hammer it into the wall at the required point. So here, too, there was a missing link or premise in the chain of reasoning. In this case, the argumentation scheme is that of goal-directed practical reasoning. To support this premise, it was necessary to shift temporarily to a negotiation dialogue. Once that premise was secure or supported properly, the deliberation could proceed on that basis. The fourth component common to these cases is that of the argumentation scheme, which seems to make certain demands that can only be fulfilled by a functional embedding between two different types of dialogue. The relationship of the four components is represented in figure 6.3. Any method of formalization would have to bring these four components together. For a functional embedding, there has to be a fit between the two adjacent

dialogues, of such a kind that all four components fit the two dialogues together in the right way.

When evaluating argumentation in any case where a dialectical shift has occurred during the sequence of argumentation, the following general method is appropriate, judging from the cases considered above. The first step is to reconstruct the chain of argumentation during which the shift was evident. The tools here are the argument projector, the argument diagram, and the argumentation schemes. The second step is to construct a profile of dialogue representing the sequence of moves and replies over the stretch of dialogue in which the selected argument took place. The profile of dialogue should be represented in such a way that the type of dialogue is indicated at each move.

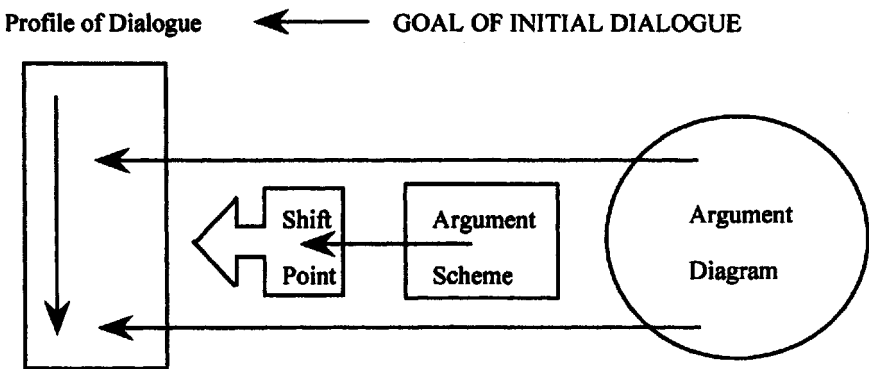

Figure 6.3: Goal of New Type of Dialogue

Thus, all dialectical shifts during the sequence of argumentation will be identified on the profile. The profile should also show which argumentation scheme has been used in any instance of the use of an argument. The third step is the comparison or matching up of the profile of dialogue and the argument diagram. By looking at both together, an argument evaluator can see the points where a shift has been made to back up some argument put forward in the initial type of dialogue. A key premise, for example, that has been supported by an argument situated around a functional embedding, can be picked out. Once all this has been carried out, the job of analysis and identification of the argument has been completed. Then the job of evaluating the argument can begin.

To evaluate the argument, the shifts both into the new type of dialogue, and back to the old one, should be examined. Then all four components cited in section 7 of this chapter need to be examined closely and critically. To see whether the dialogue interlude can properly be certified as a functional embedding, all four components need to be considered as a package. The global

context of dialogue is the first factor. Basically, the question to be asked is how the second type of dialogue supports the goals of the first. Some kinds of cases are fairly routine. A shift from a persuasion dialogue to an information-seeking type of dialogue, for example, is extremely common. But even if it is clear that the information-seeking dialogue is appropriate and useful generally, still the particulars of the shift at the local level need to be examined. It is here that all the other local factors of the argumentation scheme and so forth need to be carefully scrutinized. The fit must be right at the local level. That means the information elicited must be brought in at just the right places in the chain of argumentation in the given case. The question here is one of relevance. The information must be relevant dialectically. Bringing in the wrong kind of information does not provide a functional embedding. And the information must fit in at the right points. Going on and on, bringing in too much information, could turn what started out to be a functional embedding into an irrelevant digression.

The use of a dialectical approach to solving traditional logical problems is quite a new development and is still not widely adopted in logic as a field. However, it has been adopted in recent work in artificial intelligence, especially in the branch of that field concerned with legal argumentation. In recent work like that of Prakken (1996), Vreeswijk (1997), Lodder (1998), and Prakken and Sartor (1998), a case-based dialectical approach is brought to bear, which views a legal case as containing opposed arguments on an issue. In a typical case (Prakken, 1996, p. 334) the pair of central arguments have opposed conclusions. To study the argumentation in a case, to judge important factors like relevance, a multi-layered approach is needed. Prakken and Sartor (1998, pp. 234-236) distinguish four layers that need to be integrated in the study of legal argumentation. The logical layer provides the structure of single arguments in which premises are combined to support a conclusion. The dialectical layer defines how conflicting arguments can be relevant in a dispute. The procedural layer regulates how an actual dispute can be conducted, for example, by rules of debate or legal rules of procedure in a trial, like rules of evidence. The heuristic layer, the fourth layer, concerns strategies for rationally conducting a dispute within the procedural boundaries of the third level. The method of this book can be called dialectical, in a way that expands progressively from the logical to the dialectical, and from there to the procedural and heuristic layers. All four layers are necessary in order to present an approach to relevance that is useful in solving the fairly difficult problems posed by fallacies of irrelevance in legal and political argumentation.

In applying the new method, it is important to recognize that there are many factors that supply the evidence needed to judge relevance. There are four general or global factors that determine relevance in a given case: (1) the type of dialogue, (2) the issue of the dialogue in the particular case, (3) the stage of the dialogue represented by the discourse in the given case, and (4) the specific

rules or conventions that apply in cases where the argument occurs in an institutional framework regulated by some code or set of agreed upon regulations. Examples of the fourth factor would be a legal argument in court, where legal rules of procedure and evidence apply, or a political debate, where a handbook of parliamentary or congressional rules of order and conduct of debate is used by a Speaker to regulate the debate. Unlike the fourth factor, however, the first three factors are applicable to all cases of arguments. Specific codes or sets of procedural rules, like the legal rules of relevance and the rules of relevance used in political debates, can be used to block out as irrelevant moves or arguments that really are relevant (in a logical or dialectical sense). A judgment that an argument is relevant or irrelevant in a trial, for example, may be partly based on logical relevance. Forms of argument like reasoning from analogy, reasoning from principle and reasoning from precedent are not only characteristic of logical argumentation generally. They are also found in legal argumentation (Hohmann, 1990, p. 153). But a judgment of relevance in legal argumentation is not based only on logical relevance. It is also based on evidence rules like the FRE. Thus, to deal with cases of political and legal argumentation, an additional layer needs to be added that takes such rules into account. Before the problem of the relationship between logical relevance and legal relevance can be fully solved, more work needs to be done on the concept of the fair trial as a context of dialogue. The fair trial, as hypothesized here, is dialectically based on an embedding of an information-seeking type of dialogue in a critical discussion or persuasion type of dialogue. But this hypothesis is quite new to legal philosophy and needs much more study for it to be fully explored. Once more is known about the fair trial as a normative model of legal argumentation, the deeper relationship between logical relevance and legal relevance can be more fully investigated. For the present, the new theory of dialectical relevance offers a fresh way of looking at the logical basis of relevance in the law of evidence. A new and potentially fruitful way of analyzing relevance in legal logic and evidence theory has been opened up.

There are six more specific factors that also determine relevance in a given case. These are (1) the type of speech act in question; (2) whether that speech act is appropriate at the stage in the dialogue where it was put forward as a contribution; (3) the relationship of that speech act (at that particular point in the sequence of dialogue) to speech acts either immediately before or after it, to which it was supposed to be a response; (4) the relationship of that speech act to more remote prior and/or subsequent moves in the connected sequence of reasoning in the dialogue; and (5) the relationship of various parts of the speech act to other parts of it.

There is also a sixth factor that can be very important to determine relevance. In the kind of case where the speech act in question is an argument, its relevance will also be determined by the form of that argument. The first question is whether the argument is in the form of the right kind of

argumentation scheme to be used in a given dialogue, and at that particular stage of the dialogue. If it does have the form of an argumentation scheme used appropriately at that point in the dialogue, that form will determine whether or not a given reply to the argument (say, at the next move in the dialogue) is relevant or not. Each argumentation scheme (Walton, *Arg. Schemes*, 1996) has a set of appropriate critical questions matching it. The critical questions determine whether or not a next move in a dialogue exchange is relevant in relation to an argument having been put forward at any given move in the dialogue. For example, if the argument advanced had the form of argument from analogy, based on a comparison between two situations  $S_1$  and  $S_2$ , then an appropriate question in responding to that argument would be, 'Are  $S_1$  and  $S_2$  really similar to each other?' However, if the argument in question was not an argument from analogy, but was based on some other argumentation scheme, like appeal to expert opinion, then the above question would not be relevant as a next move in responding to that argument in a dialogue.

Where the speech act is an argument, the parts of the argument are the premises and the conclusion. Generally, the argument as a whole can be evaluated as relevant or not, as used in the broader context of the dialogue of which it is (supposedly) a part. However, the individual parts of the argument can be evaluated at a local level, as to whether they are relevant to each other. For example, it might be asked whether a particular premise of an argument is relevant to the conclusion of that argument. It is this local level of analysis that appears to be appealed to in so many of the textbook accounts of the *ignoratio elenchi* fallacy studied in chapter 5.

Ideally, a local-level analysis of the sequence of moves in a dialogue just adjacent to the particular move in question should be fitted into a global-level analysis. At the global level, the specification of the type of dialogue and the issue of the dialogue are the most important factors in judging relevance. But ideally, if enough information is given in a case, the local-level and global-level analyses of the case should be fitted together, and weighed as a whole. The combined methods of argument extrapolation and profiles of dialogue together present a structure that represents a new dialectical theory of relevance. Now it is interesting to ask how the theory can be extended and developed so that it can be applied to the many different kinds of problems relating to relevance.

## 8. EXTENSIONS OF THE NEW THEORY

This section takes up a number of problems in developing the dialectical theory of relevance further. A hope for further research is that dialectical methods for determining relevance will be built into a software program for teaching critical thinking skills (a critical thinking tutor) or a series of such software programs relating to the different types of dialogue. The new dialectical theory already fits



into a format that is highly compatible with recent developments in AI, but needs to be extended in several respects. Some new developments in multi-agent systems and case-based reasoning, in particular, are featured in this chapter. At the end of it, a summary of the new dialectical theory of relevance is given.

One nice aspect of the new pragmatic theory of dialectical relevance is that it is expressed in a computerized model that is already widely in use in AI. So computer software systems to judge dialectical relevance can be constructed. A big advantage of the new pragmatic theory, in fact, is that it is completely expressed within concepts that can be mechanized in current computer systems. Modeling dialectical relevance in a knowledge-based system of automated reasoning appears to be an implementable task. In particular, the methods of forward and backward chaining of inferences in a database are already well established and widely used. It seems then, that there should be no insurmountable problem in developing software for relevance testing. But, as always, when applying any formalized model to real cases, there are some problems.

One problem with applying the method of argument extrapolation to real cases is that the parameters are not precisely fixed, as they are in a computerized system. In a computerized system, the knowledge base, that is, the set of propositions in the database, is fixed and can be precisely determined. You can search through the knowledge base and determine whether a given proposition is in it or not. Also, in a computerized system, the set of valid inferences (like *modus ponens*) tends to be quite small and, once again, is fixed exactly (Russell and Norvig, 1995, p. 272). But in a real case of everyday disputation or, to cite another kind of example, in a legal case, these two parameters are not so easy to fix precisely, and they tend to be much larger and more difficult to agree on or to pin down. There could be all kinds of different types of inferences in use. And what is known in a given case, or what may be assumed to be the body of given information or evidence in the case, is a set of propositions that may be somewhat elusive. There might be all kinds of assumptions that appear to be part of the case. But they may only be presumptions—propositions that it would be reasonable to assume were implied in a case, but that have not been explicitly stated anywhere in a database from which they can be extracted by any straightforward process of searching.

The problem is that judgments of relevance in a real case are highly contextual. When making judgments with regard to a real case, details may be sketchy, depending on how much information concerning the case is available. You, as a critic, have to make assumptions about what type of dialogue is involved and what kind of background information would be reasonably taken to represent common knowledge in such a case. You have to have a grasp of the kind of reasoning that would normally be used to draw inferences from this given database. Then you have to make an imaginative leap to judge whether the forward chaining of the reasoning from this given base of data would

plausibly produce a line of argumentation that would have a significant probative impact on one side or the other of the pair of propositions to be proved or disproved.

All of these parts of the task of determining dialectical and material relevance in a given case involve the making of assumptions that are hard to prove or disprove conclusively in a given case. Instead, the judgment will be contextual in nature. Due to your experience in dealing with the kind of case at issue, you make an extrapolation to judge whether some move in an argument is relevant or not. The extrapolation is based on whether this move seems likely to move the line of argument forward toward the conclusion to be proved or not. If it doesn't look dialectically relevant in this sense, then your next move should be to query the arguer or at least to raise the question of whether or how it is relevant. The arguer, or anyone who chooses to defend the move as relevant, can then reply by filling in more of the details of the case. Thus the move in question can be shown to fit in with a line of argument that moves toward the conclusion to be proved.

The solution to this application problem comes in two parts. The first is the realization, already stressed elsewhere, that dialectical relevance should be seen as a procedural matter. When a critic evaluates a given argument used in a real case, her task should be seen as one of raising critical questions about whether that argument is relevant. It should not be one of declaring irrelevance in an open-and-shut fashion that leaves no room for the proponent of the argument to respond. The other part of the solution is the recognition that any argument in a real case, as presented to a critic or would-be argument evaluator, will leave many gaps in interpretation. Such gaps can only be filled in as assumptions or at least as presumptions that can be supported by the textual evidence. In any real case, a method of argument reconstruction, of the kind presented in previous chapters, needs to be applied to the case, to determine or at least evaluate nonexplicit premises, and other needed assumptions that have to be assessed.

Previously in the formal dialectical structures used as normative models of argumentation, the two participants in a dialogue have been thought of essentially as repositories of commitments (Hamblin, 1970; Mackenzie, 1981; 1990; Walton and Krabbe, 1995). The concept of participant has not been fully analyzed, or attracted much attention, other than saying two participants, called the proponent and the respondent (opponent), each makes certain moves, according to the procedural rules for the dialogue.

However, with the advent of multi-agent systems in AI, new resources for considering formal dialogue have been introduced by the concept of an agent. An agent is an entity that has goals and can carry out actions, and can observe its external circumstances, including the verbal reactions of another agent to its verbal actions, and can change its goals and actions, in light of this incoming information (Wooldridge and Jennings, 1995, p. 116). A participant in a

dialogue can usefully be viewed as an agent, an entity that produces verbal messages (speech acts), and then reacts verbally in the ensuing dialogue by receiving information on how the other party has responded.

The hypothesis put forward in this chapter is that the participants in a dialogue should be modeled in dialectical logic as a pair of agents, each reacting to the speech acts of the other, producing a connected sequence of moves (replies) in the dialogue. It can then be shown how one of the most important advantages in such a restructuring formal dialectic is that certain types of arguments traditionally called informal fallacies, particularly the *ad hominem* and *ad verecundiam* arguments, can be modeled much more perspicuously by this new technology. In particular, a way of modeling the concept of a participant's credibility as an arguer can be devised that is extremely helpful in analyzing and evaluating these kinds of arguments. According to Jennings and Wooldridge (1995, pp. 367-368), when an agent must reason with uncertain or conflicting information, it must evaluate information received from another agent as "highly believable" or "with great mistrust."

So what, more exactly, is an agent, in the new multi-agent systems? Wooldridge and Jennings (1995, pp. 116-117) distinguish between two notions of agency. According to the weaker notion, an agent is a software-based computer system that has the following four properties (p. 116).

1. *Autonomy.* Agents have some control over their actions and internal states, and can "operate without the direct intervention of humans or others."
2. *Social Ability.* Agents interact with other agents (and possibly humans) via some kind of agent-communication language.
3. *Reactivity.* Agents perceive their circumstances, and can react to them "in a timely fashion".
4. *Pro-Activeness.* An agent can "take the initiative" instead of just reacting to its environment.

In addition to this weaker notion of agency, Wooldridge and Jennings (1995, p. 117) cite a stronger notion of agency. One of the characteristics of this stronger notion is that of *veracity*, "the assumption that an agent will not knowingly communicate false information" (p. 117). It is this characteristic that is particularly important in evaluating the relevance of *ad hominem* arguments. In a multi-agent dialogue when one agent uses a personal attack argument to question the veracity of another agent, the argument could, in principle, be relevant because the assumption that an agent has veracity is an important part of the collaborative functioning of the dialogue, as it moves toward its goal. At any rate, by thinking of a participant in a dialogue as an agent, a whole new dimension is brought into the structures of all six basic types of dialogue. And this new agent-based structure of dialogue will help to provide a better model for evaluating relevance and irrelevance. There is much work to do in dialogue

theory, and computational dialectics is still a new field of AI research. But many of the existing methods of AI can be adapted to the task of evaluating argumentation for relevance.

To sum up, there are two methods for determining relevance in a case: the dialogue method and the argumentation method. Let's consider the argumentation method first. In this method, the initial data given in the text of discourse can be used to construct an argument diagram. This diagram represents the argument as given in a text of discourse. But how is relevance judged from that data? According to the argumentation method, the data has to be chained forward to see if it can reach the goal or conclusion to be proved. A method of this kind to judge cases containing circular argumentation was presented in (Walton and Batten, 1984). It starts with an argument diagram representing the text of discourse in a given case. Then a set of inference rules is used to develop the line of argumentation in the diagram further to see where the line of argumentation leads. If it is shown to go in a circle, this evidence can be used to help judge whether the fallacy of begging the question has been committed. But the same kind of methodology can be used to help judge whether an argument is relevant. The given premises and conclusions are represented by the argument diagram. The rules of inference are used to chain forward from these given points to see what other conclusions can be generated. The question of relevance is determined by whether the argumentation can be chained far enough forward to reach the conclusion to be proved as the final end state or target.

Now let's consider the dialogue method. A dialogue can also be seen as a sequence that starts from some given state, and then is transformed into new states through various rules that apply to each move in a sequence of moves. A difference between the dialogue method and the argumentation method is that two participants are involved in the dialogue method. Each takes a turn, and it is this sequence of turns or moves that makes up the path from some initial state leading toward the goal. The sequence can be generated automatically because each move to the next move is governed by four kinds of rules: locution rules, structural rules, commitment rules, and success or failure rules. The success or failure rules determine whether a given dialogue has successfully reached its goal state or not. Thus, a dialogue, like an argumentation chain, can be seen as an orderly rule-guided sequence that starts out from some particular point and then moves forward toward an end point that is designated in advance. So given any text of discourse representing some dialogue moves, you could use a formal model of dialogue to extrapolate forward, using the dialogue rules that determine when each next move is legitimate or not, and judge whether the sequence of moves has reached the end point or not.

Thus, both the argumentation method and the dialogue method can be represented as heuristic search procedures that move from some given data or initial points with the supposed aim of reaching some designated end point as

their goal. In this respect, they are typical of the kind of state-space mechanisms familiar in artificial intelligence, in fields like planning, problem solving, and heuristics. The problem is how these AI techniques can be adapted to current methods used in argumentation theory to identify, analyze, and evaluate arguments and dialogues in a given text of discourse. The answer is that the process should begin with the standard argument diagram of the kind currently used in argumentation and informal logic. But the argument diagram should be seen as a graph representing the premises and conclusions of the given argument as the initial points in a search procedure that can be extrapolated forward by applying certain rules over and over again. It can thus be used to produce new conclusions inferred from the initial ones, or to extend a dialogue. The problem of relevance can then be posed as the question of whether the sequence can be extrapolated forward, from the given points by the rules, to an end point that has been designated as the goal.

## 9. LIMITATIONS OF THE NEW METHOD

The problem of determining relevance in a given case is rarely as straightforward as the previous theoretical account may suggest. In applying the method of argument extrapolation, there can be premises used in the argument that were not explicitly stated but only presumed. There can be problems of determining what somebody really meant, so several interpretations of that person's argument may be possible. There can be problems of determining what the prior sequence of dialogue was, simply because the given text of discourse in a case is incomplete and sketchy. In many cases of the kind dealt with in logic textbooks, no record of the previous moves in the dialogue may have been kept on record. Or in a given case, we may be given only a small part of a larger sequence of argumentation so that, in effect, the text of discourse that actually confronts us is seriously incomplete. Hence, it needs to be understood that in some cases, the new method will not determine whether an argument is relevant or not, simply because of insufficient information.

According to the pragmatic definition of dialectical relevance, an argument, or other move in a dialogue, is *dialectically relevant* (in that type of dialogue) if and only if it can be chained forward, using either the method of profile reconstruction or that of argument extrapolation (whichever is better applicable to the given case) so that the line of argumentation reaches one or the other of the pair of propositions that defines the issue of the dialogue. In the new dialectical theory of relevance, whether an argument (or move in a dialogue) is to be judged relevant depends on the context of dialogue that this argument (or move) was part of. Basically, such an argument (or move) is relevant if it is part of a chain of reasoning that has the material potential to prove what is at issue in a dialogue.

It is important to realize that when dialectical relevance is defined as above in the new pragmatic theory of relevance, one special meaning of the term *relevance* is being singled out as the most important meaning for use in argumentation theory (the applied logic for evaluating arguments). An argument, or other move in argumentation, is deemed to be “relevant” in this special dialectical sense if it contributes or has the potential to contribute to the line of argumentation that extrapolates toward the goal of the dialogue of which the argument is supposed to be a part. Thus, an argument could be “relevant” in some broad sense, yet fail to be dialectically relevant in the sense defined in the new pragmatic theory.

In theory, it is possible to define relevance in a formal system of dialogue, like one of the systems presented in Walton and Krabbe (1995). A proposition, question, or any unit of speech that could be used as a move or part of a move in formal dialogue system *D* is *relevant* in *D* if, and only if, it is a legitimate move (or part of a legitimate move) in *D*, according to the rules of *D* that define what constitutes a legitimate move, and it is connected by an ordered sequence of prior legitimate moves to the original conflict-description (issue) of *D*, insofar as such information has been given in the case in point. For example, the general description of the characteristics of permissive persuasion dialogue given in Walton and Krabbe (1995, p. 133-140) sets out a list of eighteen rules that define the kinds of moves that are permissible in this general kind of dialogue. These rules also determine what is, or is not, a legitimate sequence of moves in a permissive persuasion type of dialogue, and therefore can also serve as part of the evidence used to determine whether or not a given argument (question, assertion, etc.) is relevant in that type of dialogue. The structural rules that determine which type of move is permissible in response to another move, are especially useful for this purpose. To be relevant generally, a move has to be placed at some proper point, according to the rules, in a sequence of arguments or dialogue exchanges. The sequence projects forward to the originating conflict description (see p. 133) that poses the issue of the dialogue.

Theoretically then, it is possible to determine exactly whether an argument (question, etc.) is relevant or not, as used in a formal system of dialogue. This ability to determine relevance of a pragmatic kind in a precise way in a formal system is quite exciting because it means that we can not only define relevance formally and precisely, but can also calculate exactly whether something that purports to be a move in dialogue is relevant or not (relative to the rules for that type of dialogue).

The problem with applying this theoretical systematization of relevance to a given text of natural language discourse, is that for a complete evaluation, a lot of information is required to be available concerning the prior moves made in the dialogue exchange from the original issue to the move in question. Also needed is information about the type of dialogue the case supposedly is part of, and the rules for that type of dialogue. What these factors indicate is that, for the

theory to apply optimally to a given case, the argumentation in the case should be presented in adequate detail. In general, then, a given case should be quite a substantial text of discourse.

Clearly however, such an extensive detail of case presentation is a far cry from the examples cited in the textbook treatments of relevance surveyed in chapter 3. The cases given there are nearly all very brief, with little or no contextual information given that would situate the argument in a longer sequence of exchanges in a dialogue setting. For example, in case 3.9, cited by Damer, only two premises are given as the basis of the argument put forward to support the conclusion that all Americans should regularly go to church on Sunday. One is that Americans have a great heritage built on fine ideals. The other is that they should all help to sustain this great heritage by passing it on to their children. That is all the information we have in order to make a determination of the relevance of the premises to the conclusion in the given argument.

The problem, as noted in the discussion of this case, is that there could be a connection between the premises and the conclusion supplied by the intervening premise, 'Going to church on Sunday is part of the American heritage.' But can such a premise justifiably be inserted into the chain of argumentation attributable to the speaker in this case? Damer's assumption, in classifying the argument in case 3.9 as an instance of the fallacy of missing the point, is that such an attribution is not justified by the text of discourse given. The evaluation is made on the basis of a default inference. Because the intervening premise is not explicitly stated in the text of discourse, it may be assumed it is not part of the speaker's line of reasoning. But in view of the brevity of case 3.9, and the fact that so little information about the actual details of the argument exchange was given, can we really say whether the premises are relevant to the conclusion or not? Damer interprets the case in such a way that he assumes that the speaker is pontificating, digressing about "fine ideals" and the like, instead of offering a materially relevant argument. But the assumption is that case 5.9 represents all that the speaker said (or at least, all that was relevant) in the exchange on whether Americans should go to church on Sunday. Encouraging students to think that they can routinely make such an assumption and declare, on the basis of such a short body of evidence, that a fallacy of relevance has been committed, is misleading, because it reverses the proper burden of proof. This pre-emptive kind of evaluation presumes that an arguer is guilty of committing a fallacy of relevance without giving the details of a case a proper examination.

## 10. IRRELEVANCE AS A PROCEDURAL CHARGE

To deal with a criticism of irrelevance in a particular case, enough of the right sort of textual and contextual evidence is required. There are two kinds of problem cases. One is where there is too much information, and a judicious selection of evidence is needed. The other is where too little information is given. Let's consider the second type of case first.

The profile of dialogue and the argument diagram are well suited to cases where the evaluator wants to single out a relatively short argument that is part of some more lengthy text of discourse. That is typically what we do in analyzing fallacies and the like in informal logic. But what about a longer argument of the kind one might find in an article or even a book? In the analysis of a lengthy case of extended argumentation, one might expect to find many functional embeddings throughout the long chain of argumentation. What about the student essay case considered earlier? What you would expect to find in such a case would be a lengthy persuasion dialogue peppered with subdialogues of the information-seeking kind. The essay will be full of arguments. But it will also be full of empirical assertions that are taken from sources. These sources will typically be books and articles written by historians. Many of them will be quoted, and references will be given to author, title, and so forth, so that the source can be checked by the reader of the essay. As noted in section 4, the argumentation in the essay will shift back and forth between the main line of argumentation in the persuasion dialogue and the information-seeking dialogue used to provide the premises on which the persuasion dialogue is based. Thus one would find plenty of instances of functional embeddings throughout the argumentation.

In evaluating the argumentation in such a case, a critic, for example, someone who has to grade the essay, would typically look for the weakest points in the chain of argumentation and then concentrate on the local argumentation at these points. So the profile of dialogue, along with the argument diagram used to pick out specific localized arguments, is the analytical tool of choice. But functional embedding is also an important consideration in such cases. Typically, the part of the argument that is most interesting from a critical point of view is the part relating to how a source has been used. It will be asked whether the source has been correctly quoted, what may be inferred from what the source was taken to have asserted, whether other sources were consulted, whether the sources agree, and so forth. These considerations are all relevant for evaluating an appeal to expert opinion or for evaluating other sorts of arguments involving a shift to an information-seeking dialogue.

The case of the student writing an essay on how Hitler was appointed Chancellor shows the practical dimension of the problem. Consider the following question. When should the collection of historical information stop? As noted in the discussion of this case, this question raises a nontrivial practical



problem for all writers of essays. A decision has to be made on when to stop engaging in information-seeking and start composing argumentation that will make up the critical discussion in the essay. But this decision is presumably not one that can be made by reference to formal properties of the persuasion dialogue or the information-seeking dialogue. It is a decision that will be affected by how much time the writer has available to collect information and by the writer's estimate of when he thinks he has exhausted the relevant information that is available. Such factors seem to fall outside the structure of the normative models of dialogue involved. They seem to be practical in nature.

The scope of the problem can be narrowed by thinking of the problem in a less abstract way. This can be done by restricting the kind of case considered to the following type. The dialogue has already been completed. Or at any rate, we are presented with some text of discourse in which the argument has been stated. All of us as critics have access to this text of the case being evaluated. It is useful, also, to assume that we have some evidence indicating what type of dialogue the participants were originally supposed to be engaging in. In other words, in the given case, we have some idea of where the argument started out and of the argumentation that has already been put forward. In the given case, we can then look at the text of discourse and make some judgments about where dialectical shifts occurred and what type of dialogue was shifted out of and into.

This kind of case is different from the one faced by an essay writer when making a decision about whether to continue collecting information. In the kind of case we are now considering, the essay writer has finished, and we are looking over the text of the essay. We presume the general format is that of a critical discussion on the topic of why Hitler became Chancellor, for example. We are trying to determine, looking over the argumentation in the essay, where and how interludes of information-seeking dialogue are embedded in the persuasion dialogue. The problem now posed is how we pick out these embedded information-seeking subdialogues and judge whether they are functionally embedded into the main persuasion dialogue. The tools we need for this kind of analysis must be capable of dealing with the evidence available. In a case like this, a good deal of analysis of the larger body of evidence in the case may have to accompany the profile of dialogue and the argument diagram. A kind of commentary on the case may be needed. The evidence may have to be sifted out, analyzed, and condensed before the profile or the diagram can be usefully employed.

The other problem with evaluating relevance in particular cases, as observed, is that too little information may be given in a case on what type the dialogue is supposed to be, what the issue is, what sequences of argumentation led up to the part quoted in the case, and so forth. Because of the lack of such information, particularly in the kinds of examples given in the textbook treatments, a conditional evaluation is the best that can reasonably be expected.

Another more specific problem is that, even if more textual and contextual information of this sort is presented, as in more lengthy cases of material relevance, the argumentation in the case may not yet be completed. For example, in cases like 1.2 and 3.10, it appears that the designated argument occurs in the middle area of the argumentation stage of a dialogue that is still underway. In such cases, whether that designated argument turns out to be materially relevant or not depends on how the lines of argument go from there on both sides of the continuing dispute. In such cases, a speaker who is challenged on the ground that his argument is not relevant may ask for some leeway to show that, as he develops his line of argument further, it will become clear how the point in question is relevant.

It seems, then, that in practice, in many cases, there may be insufficient information to simply declare, in an absolute way, that somebody's argument is irrelevant. It would seem far more reasonable and appropriate in such cases to put the charge of irrelevance in a qualified and conditional way. The form of such a charge would be, 'Your argument appears to be irrelevant to the point at issue, so unless you can show how it is relevant, it would be more productive for you to leave off this argument, and get back to the point at issue'. So taken, the charge is put in the form of a request to get back on track, based on a questioning of the relevance of the argument currently put forward.

Here, irrelevance is conceived as a procedural charge against a given argument (or other move in a dialogue). The way is left open for the speaker to reply by giving some indication, or sketch of a connecting sequence of argumentation, that would relate his argument to the issue of the dialogue as a whole. The charge is procedural, in the sense that it leaves the way open for the proponent to reply to it. But if the proponent does not reply, then the presumption is that he will not pursue this particular line of argumentation any further in the dialogue.

This way of conceiving the charge of irrelevance has significant implications for the concept of a fallacy of relevance. According to the theory outlined in Walton (*Prag. Theory*, 1995), to say that a participant in a dialogue has committed a fallacy is quite a serious charge. It needs to be backed up by appropriately strong evidence that the participant's argument (or other move he made in argumentation) either shows a recognizable pattern of deceptive use or is an instance of a recognizable, and serious, systematic error of reasoning. So there is an important distinction between a mere blunder in the use of an argument in a dialogue, and the committing of a fallacy. The consequence of this general view of the concept of a fallacy is that not all failures of relevance in argumentation are fallacies. Accordingly, in many of the cases studied in chapters 1 and 5, it would be more reasonable and appropriate to put forward a procedural charge or criticism of relevance, as opposed to claiming that a fallacy of relevance has been committed.

Drawing the line between judging that a fallacy of relevance has been committed, and only judging that relevance should be questioned, is a task for each individual case. The general point to be made is that relevance should generally come into the evaluation of a dialogue as a procedural charge challenging a speaker to show relevance. The idea of irrelevance as a procedural charge, relativized to a procedure or type of dialogue in which a given argument is contextually embedded, is a difficult one for many people to accept, or even to grasp at first. Many critics see the project of relativizing relevance to a context of dialogue as a postmodern questioning of rationality and logic, and find it unsettling and deeply objectionable. Others just do not grasp the idea of procedural relevance as being relative to a type of dialogue. What needs to be recognized is that, in order to make judgments of dialectical relevance or irrelevance, the kind of evidence required to support or criticize such judgments comes both from the text of discourse and the context of dialogue.

The tricky thing to watch for, in many cases, is that the same argument could be relevant in one context of dialogue but irrelevant in another. Sometimes arguments seem relevant because it is not very clearly stated which type of dialogue is being engaged in. In other cases, because of a dialectical shift from one type of dialogue to another, an argument might seem relevant while not really being relevant at all. It is precisely in these kinds of cases that fallacies of relevance tend to occur. The shift makes an argument seem relevant when it is not, and the argument's failure of relevance is concealed. Not every shift conceals a fallacy, however. If one dialogue is functionally embedded in the other, the argumentation can actually contribute to the goal of the first by shifting to the second dialogue. In such a case, relevance is preserved over the shift. The evaluation of relevance and irrelevance requires an examination of each case on its merits. It requires a secondary judgment, on the basis of the textual and contextual evidence given, whether a shift represents a functional embedding or an illicit shift.

## Fallacies of Irrelevance

The most important goal of this project has now been achieved. A normative theory of dialectical relevance has been developed, and it has been shown how to apply this theory to determine whether or not an argument or move in argument is relevant in a given case. This new method of evaluating cases for relevance is the tool so badly needed for many purposes of teaching critical thinking and argumentation skills. One of the most important tests of the new dialectical theory is to see how it can deal with the various informal fallacies that, in the logic textbooks, are so often diagnosed as failures of relevance. Is failure of relevance itself a fallacy? Is there one central fallacy of irrelevance, apart from other fallacies like *ad hominem*, *ad baculum*, and others, that seem to be fallacious on grounds of irrelevance? Each of these fallacies has been analyzed elsewhere in the literature, and chapter 7 is not the place to offer a full analysis of any of them individually. The pressing problem for the present chapter is posed by the textbook treatments cited in chapter 3, showing that irrelevance is treated as a “rag bag” category. The textbook treatments of *ignoratio elenchi* and related fallacies of relevance give some guidance on what is needed to deal with the problems posed by the examples they cite, but they do not state exactly what relevance is, or should properly be taken to be, for these purposes. Moreover, the examples they cite are brief, and their treatments of them are dismissive, problematic, and unconvincing. In the past, it has seemed hard to know where to turn to get a better idea of what is, or should be meant, when an argument (or part of an argument, or a move made in the context of an argument) is said to be irrelevant.

The first step needed is to re-examine some of these examples in more depth in light of the new dialectical theory of relevance. The textbooks have followed and continue to follow the longstanding tradition set by Aristotle’s *On Sophistical Refutations* by placing the primary emphasis, in matters of judging relevance, on the *ignoratio elenchi* fallacy. A problem that remains then is to give an analysis of this fallacy (or at least to reach some conclusion on what to do with it) and situate it in relation to the broader category of fallacies of irrelevance. In chapter 7, the *ignoratio elenchi* fallacy is shown to be one among several other basic fallacies of irrelevance. A new scheme of classification of these fallacies is presented in chapter 7.

## 1. THE NEW DIALECTICAL THEORY OF FALLACIOUS IRRELEVANCE

In this section, an outline of the new dialectical theory of fallacious irrelevance is presented, prior to applying the theory to cases. In the new dialectical theory, the basic problem with fallaciously irrelevant argumentation in a dialogue is that it is useless when it comes to being extrapolated forward to fulfill the goal of the dialogue. In the new dialectical theory, an irrelevant argument (or line of argumentation) is not just a probatively weak one. It is one that does not show enough promise of becoming strong enough to prove or settle what is supposed to be proved or settled as the dialogue proceeds. The new theory gives rise to a natural hypothesis to explain fallacies of relevance. Such fallacies are explained in relation to argument extrapolation, of the kind outlined in chapter 6, as used in conjunction with the profiles of dialogue method. Fallacies of irrelevance occur because of failure to properly extrapolate forward so that the sequence of argumentation ends in the conclusion that is supposed to be proved in a dialogue. On the new dialectical theory, such a failure can occur for two basic reasons. One is that the audience (respondent) is distracted by the direction the argumentation is taking and finds it very stimulating, so they lose track of where the argument is supposed to be going. The other reason is that it may look like the argument is going in the direction of proving the conclusion to be proved, but in reality it does not have the potential to prove that conclusion. It is the second of these that is the central fallacy of irrelevance. The first, which could be called the *fallacy of distraction or diversion*, is a special subtype of the second.

In the new theory, the first type of fallacy, the distraction or diversion type, is called the *red herring fallacy*. The other one is called the *fallacy of misdirected argumentation*. It is this fallacy that is the central fallacy of irrelevance, according to the new dialectical theory. Other fallacies of irrelevance, including the Aristotelian fallacy of wrong conclusion (*ignoratio elenchi*) and the red herring fallacy, will turn out to be subtypes of the central fallacy of misdirected argumentation. The new dialectical analysis of the central fallacy of irrelevance can be explained using figure 7.1.

The fallacious aspect of misdirected argumentation, according to the new dialectical theory as represented in figure 7.1, has to do with the pathway for completion of the argumentation. An argument commits a fallacy of misdirected argumentation if its extrapolation shows that it lacks the potential to be developed forward beyond where it terminates so that it could eventually lead to the ultimate conclusion to be proved. Fallaciousness, on this account, relates to the failure of probative potential to lead, by a sequence of argumentation in a dialogue, to the ultimate issue to be settled in that dialogue.

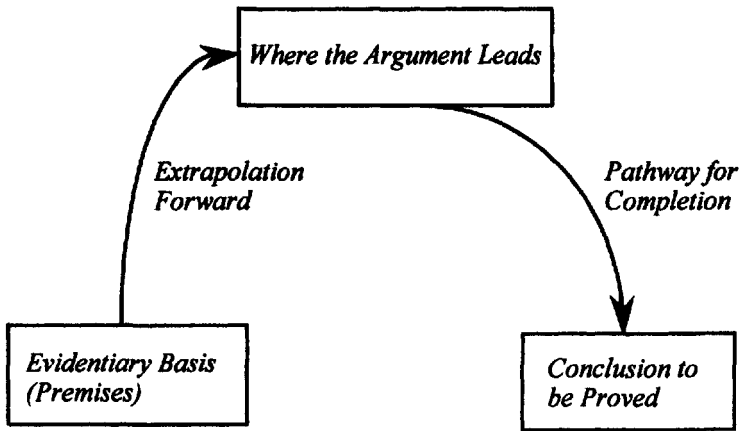

**Figure 7.1:** Dialectical Structure of the Fallacy of Misdirected Argumentation

But on the new dialectical theory, irrelevance is not always fallacious. In some cases, an irrelevant argument may slip into a dialogue without much harm being done, and the problem can easily be corrected. An irrelevant argument is only fallacious if it either blocks the progress of the dialogue entirely, or seriously interferes with its progress towards settling the ultimate issue. The fallacious kind of irrelevance occurs where the argumentation used is a tactic to deceptively get the best of a speech partner in a dialogue. Fallacies involve tricky tactics of deception and distraction.

In the new dialectical theory, relevance is defined in terms of probative weight. But that is not the only factor. An argument is not irrelevant exclusively on the ground that its premises lack the probative weight required to support its conclusion adequately. We (as critics) properly judge an argument to be dialectically irrelevant in a dialogue because, looking ahead, we can estimate or judge that it is not going anywhere. Or more specifically, it lacks the potential to arrive at the ultimate conclusion to be proved or disproved in the dialogue, as far as we can tell at this point in the dialogue. But dialectical relevance is a procedural matter. If a respondent objects to a proponent's line of argument by saying it is irrelevant, the proponent may reply that, if he is allowed a little latitude to develop the argument further, the respondent will then see why it is relevant. In other words, irrelevance is different from mere insufficiency to prove a conclusion. Irrelevance has to do with the probative potential of an argument in a dialogue, insofar as that argument can be extrapolated forward, with a view to fulfilling its probative function. It is one whose weakness cannot be strengthened by further argumentation in a dialogue, as far as can be

reasonably judged by looking at the particulars of the case, the given evidence, and the context of dialogue. As shown in chapter 7, in many cases of irrelevance, the failure of probative potential is assured by a dialectical shift to a different type of dialogue.

The first thing to notice is that the new dialectical account of fallacious irrelevance seems to be somewhat different from the account that has, throughout the history of western logic, been taken to be Aristotle's account of the *ignoratio elenchi* fallacy. Aristotle's account, or how the logic textbooks have interpreted it, as shown in chapters 2 and 3, sees the *ignoratio elenchi* fallacy as the fallacy of wrong conclusion. In chapter 3, we saw this interpretation of Aristotle's analysis clearly expressed by Jevons (1878), who wrote that the fallacy is "arguing to the wrong point, or proving one thing in such a manner that it is supposed to be something else that is proved" (as quoted in chapter 3). Creighton (1904), Hibben (1906), Read (1898), Castell (1935), and many others, offered this same interpretation. Does Aristotle's analysis of the *ignoratio elenchi* fallacy actually conform to this traditional interpretation? The careful re-translation of the key passage from the *Topica* in chapter 2, section 1, raises grounds for doubt. The Loeb translation used the term *irrelevant*, but the more literal translation given in chapter 2 does not use the word *irrelevant* at all.

The traditional account of what was taken to be Aristotle's *ignoratio elenchi* fallacy sees it as a fallacy of irrelevance, the so-called *fallacy of wrong conclusion* or *irrelevant conclusion*. This account requires two specific conclusions: the "wrong" one and the "right" one. The fallacy is the mix-up or misidentification of the two propositions (the two conclusions). Whether this traditional account really corresponds to what Aristotle meant in his analysis of the fallacy seems to be a somewhat controversial question, however. On the literal translation of Aristotle's definition of the fallacy given in chapter 2, *ignoratio elenchi* occurs when the argument is "something other than that leading to the conclusion." This account does not appear to require another specific conclusion, different from the one to be proved. What Aristotle's analysis exactly amounts to thus appears to be open to interpretation.

At any rate, the next question the reader will wonder about is exactly what the difference is between the new dialectical account of the fallacy of misdirected argumentation and the traditional interpretation of Aristotle's *ignoratio elenchi* fallacy. In considering this question, it is useful to turn to a re-examination of some of the cases cited in chapters 2 and 3.

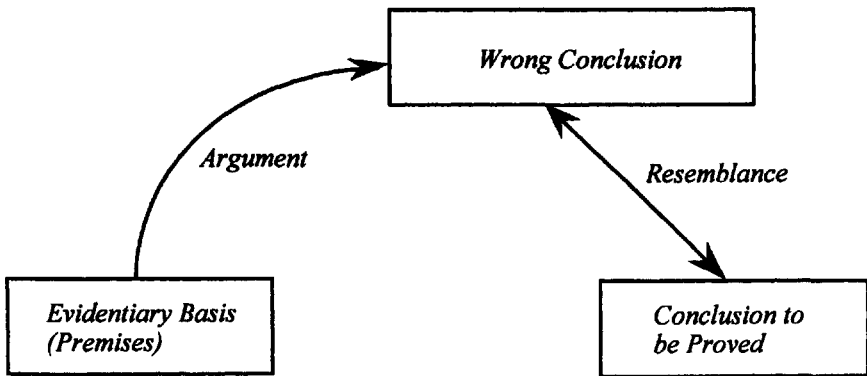

**Figure 7.2:** Traditional Account of the Fallacy of Wrong Conclusion

## 2. EVALUATION OF CASES USING THE TWO THEORIES

According to the traditional interpretation of the Aristotelian *ignoratio elenchi* fallacy, there are two specific conclusions involved and the one superficially resembles the other. For example, one proposition may look similar to the other, but may overlook important qualifications contained in it. They may look like the same proposition, when in reality they are not. Using this account of the *ignoratio elenchi* fallacy, the traditional textbook accounts proceeded by analyzing each case of fallacious irrelevance using the following method. They took the proposition to be proved, and stated it carefully. Then they took what appears to be the proposition actually proved by the argumentation in the given case, and reformulated or paraphrased the wording of it so that the resemblance to the proposition to be proved was made apparent.

For example, consider case 2.7, reprinted below:

*Case 2.7:* Instead of proving that “the poor ought to be relieved in this way rather than in that,” you prove that “the poor *ought to be relieved.*”

Case 2.7, as presented by Whately (1826) fits the form of the central fallacy of wrong conclusion exactly. But the question is why this particular argument would seem to be persuasive if actually used. Why and how does it work to deceive an audience? The answer that suggests itself, from Whately’s way of presenting the case, is that the two conclusions appear, or might plausibly appear to an audience, to be similar to each other. They may even appear to be the same proposition. But in reality, there is quite a distance between them. The proposition ‘The poor ought to be relieved’ is abstract, whereas the proposition ‘The poor ought to be relieved in this way rather than that’ is (meant to



represent) a specific proposition. Even if the first proposition is proved as the conclusion of an argument, there may be a long way to go to prove the second. In the new dialectical theory, the pathway for potential completion of the argument from one conclusion to the other leaves quite a gap open. And yet, to a recipient of the argument, the two conclusions might look quite similar.

Case 2.4 (reprinted below) can be used as another example to illustrate the point.

*Case 2.4:* Instead of proving that “this Prisoner has committed an atrocious fraud,” you prove that “the fraud he is accused of is atrocious.”

In this case, the conclusion to be proved is the proposition, ‘This prisoner has committed an atrocious fraud’. What is proved instead, the proposition that the fraud he is accused of is atrocious, is part of what needs to be proved in order to prove the proposition at issue. But the problem is that when the first proposition is proved, it may seem (to an audience, or jury) that what has been proved is the full proposition that this prisoner has committed an atrocious fraud. To prove the latter requires proving not just the abstract proposition that the fraud the prisoner is accused of is atrocious, but the specific proposition that the prisoner did, in fact, commit this fraud. The problem posed by the fallacy here is not just one of using an argument that is of no probative use in proving the conclusion at issue. The presumed solution is that the actual conclusion proved appears (perhaps superficially) to bear a resemblance to the real proposition to be proved.

But how well does the hypothesis of resemblance explain the success or *apparentia* of the fallacy of wrong conclusion in case 2.4? It does not explain it very well. The real explanation is that when the attorney proves that the fraud the prisoner is accused of is atrocious, he makes the prisoner look guilty. The arguer is (presumably) dwelling on the details of how atrocious the fraud was and using this argument to suggest that the prisoner must be a very bad person because he is under suspicion of having committed the fraud. The explanation of the *apparentia* in this case is that there appears (superficially) to be a line of argumentation that can be extrapolated forward from the conclusion actually proved to the conclusion that is supposed to be proved. This line of argumentation is, in reality, extremely weak in probative potential. In fact, it can be determined from the evidence given in the case (presumably, although the case presentation is sketchy and brief) that there is no feasible pathway allowing extrapolation of the given argumentation forward to reach the conclusion to be proved.

Much the same general kind of assessment can be made of Copi’s case of the horribleness of murder (case 1.3). It is a good case in principle, and an ancient one at that, but to make an adequate evaluation of it as an instance of the *ignoratio elenchi* fallacy, many theoretical and particular case-based

assumptions need to be filled in. The fallacy, according to Copi's very brief account (p. 72), occurs because, or to the extent that, the prosecuting attorney "infers from his remarks about the horribleness of murder that the defendant is guilty of it". The fallacy, according to Copi's evaluation, resides in a certain inference to a conclusion presumably suggested or otherwise communicated to the jury by the attorney's argument. On the new dialectical theory, this evaluation can be supported by showing that the line of argument in view does not really extrapolate successfully (as far as we can tell from the information given) to the conclusion that is supposed to be proved by the attorney. The "inference" Copi refers to, presumably, is the transference effect the attorney's claim about the horribleness of murder will have on the jury, prompting them to reason as follows: Murder is a horrible crime; therefore, the defendant, who is alleged to have committed murder, is a horrible person who is or could be guilty. This argument extrapolation, once made explicit, shows clearly what an unpromising line of argument this sequence of reasoning is. The diversionary tactic is presumably that an unreflective jury might be influenced by it, might weigh it in with the really relevant evidence more strongly than it deserves, or might even be distracted from that evidence by it.

The discussion of the FRE in chapter 1 showed how, generally, in a criminal trial, the *ad hominem* argument 'x is a bad person, therefore x committed the crime' is not regarded as admissible. Given this knowledge of the framework of the Anglo-American law of evidence, it can be appreciated how the argument in case 1.3 fails to extrapolate forward. So even though Copi's presentation of the case is sketchy at best, it is a type of case we are generally familiar with and can recognize as very important from a practical point of view. We can catch the gist of the reasoning that could be filled in (on the new dialectical theory) to support Copi's evaluation of the case as an instance of the *ignoratio elenchi* fallacy even though any serious evaluation of it (as stated) has to be highly conditional in nature. Of course, in any attempt to present either of these two cases in an introductory textbook, the best recommendation would be that it be presented in greater detail, and analyzed in much greater depth, using the new theory of dialectical relevance to pinpoint the various assumptions being made.

The explanation of *apparentia* in these two cases is not yet complete. So far, what is said to explain how the fallacy works is that, superficially, it appears that the argumentation can be extrapolated forward from one conclusion to the other, and the audience is invited to make the leap whereas, in reality, the possible path from one proposition to the other is highly problematic and dubious. Another aspect is involved as well. A tactic of distraction or diversion is involved. Rhetoric about the atrociousness of fraud or the horribleness of murder gets an audience excited and can make it lose track of what really needs to be proved in a case. This tactic of distraction is the second part of the explanation of how the fallacious irrelevance works.

For a third example, consider how Copi (1968, p. 72) justified his evaluation of the decent housing case (1.2) as an instance of the fallacy of *ignoratio elenchi*. In his evaluation of this case, Copi identified the issue the dialogue is supposed to be about when he wrote, “a particular proposal for housing legislation is under consideration. Therefore, presumably, the debate is at a certain stage prior to a vote on a specific bill, or piece of legislation.” The legislator’s argument that “decent housing for all the people is desirable” is not probatively relevant in the context of that debate because (presumably) there is no extrapolable line of argumentation from that proposition to the real issue to be resolved—whether it is reasonable to vote for or against the proposed bill. As Copi put it, “the question is: will this particular measure provide it [decent housing for all the people], and if so, will it provide it better than any practical alternative?” According to the new dialectical theory, the assumption made by this evaluation is that the context is that of a deliberation in which the assembled legislators, if they are rational, in the sense of using practical reasoning, are supposed to vote for the measure that will provide decent housing for all the people better than any of the known, practical alternatives. An argument, or other move in the dialogue, is dialectically irrelevant (in this sense) if it cannot be extrapolated by a sequence of practical reasoning so that it leads to a line of argumentation concluding in a prudent decision for one side or the other, that is, for or against the particular measure being debated. Because the legislator’s argument, “Decent housing for all the people is desirable” fails that test (by default, according to all the information given in the case), it is a dialectically irrelevant move in the dialogue, that is, the deliberation dialogue the parties are supposed to be engaged in. Moreover, to the extent that this argument shows evidence of distraction or diversion—and there is an element of distraction indicated by the level of abstraction and the failure of material relevance resulting from it, implied or suggested by the example—it can be judged (conditionally on that assumption) to be an instance of the *ignoratio elenchi* fallacy.

Hence, in this case, despite the absence of detailed technical information about the institutional setting of the debate, the example is not a bad one, and a somewhat useful conditional evaluation can be made of it as an instance of the *ignoratio elenchi* fallacy, despite its brevity and sketchiness. This evaluation, however, if it is to be useful and justifiable, needs to be broadly based on a dialectical and normative framework of the kind proposed in chapters 5 and 6 above. Once the case has been analyzed using the new dialectical theory, the explanation of how the fallacy works becomes apparent.

A conclusion of this section is that the textbook writers and other commentators on Aristotle didn’t get it quite right when they postulated that *ignoratio elenchi*, or arguing to the wrong conclusion, is the central fallacy of irrelevance. On their view, the *ignoratio elenchi* fallacy is committed when the conclusion of the argument is a proposition other than the one supposed to be

proved. However, that failure is, in itself, not necessarily fallacious, for during the course of an argument, very often an arguer will prove conclusions other than the one that is to be proved, in the end, as the goal of the dialogue. The central fallacy of irrelevance is using a line of argument that moves away from proving this target proposition, and instead goes in a line of argumentation that has no hope of ever reaching it. Thus, it is not just arriving at a “wrong” proposition, or one other than the one to be proved, that is the essence of irrelevance as a fallacy; it’s more a matter of where you are going and of what the prospects are of getting to the proposition to be proved, judging from where the dialogue has gotten so far. According to the new dialectical theory of relevance, the central fallacy of irrelevance, the fallacy of misdirected argumentation, is the dialogue’s taking such a misguided direction that projecting the sequence of argumentation is incapable of arriving at the proposition to be proved. It’s not a matter of wrong conclusion but of a failure to go in a direction that will eventually reach the right conclusion. The reason for this failure can even be a shift to a different type of dialogue with a different goal than that of the original dialogue.

Of course, there is a danger that phrasing Aristotle’s fallacy of *ignoratio elenchi* (ignorance of refutation) in terms of “irrelevance,” although everyone does it, may be a kind of misconception or mistranslation. The textbook accounts, as shown in chapters 2 and 3, freely use the terms *relevance* and *irrelevance* when describing Aristotle’s conception of *ignoratio elenchi*. It is easy to see why, because in English, *relevance* and *irrelevance* are the words conventionally used to describe cases where we run into problems of arguments going off track or diverting an audience away from an issue. Still, it would appear that Aristotle does not use any Greek term that corresponds to what we call *irrelevance*. Instead, he talks about failed refutations being ones that are “other than” those “leading to the conclusion.” Whether the traditional textbook accounts got Aristotle’s analysis right appears to be controversial.

### 3. INSUFFICIENCY AND IRRELEVANCE

The problem treated in this section has to do with drawing a distinction between arguments that are irrelevant, and arguments that are too weak to prove a conclusion. This distinction is based on what Johnson and Blair (1983, p. 34) call the *RSA triangle*, shown in figure 7.3:

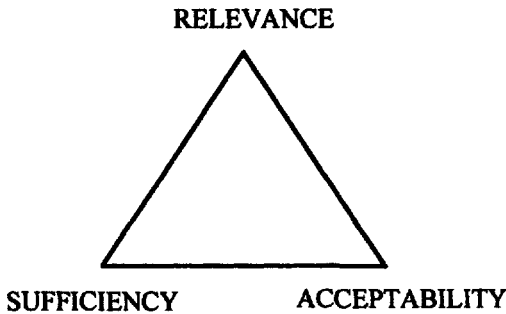

**Figure 7.3: RSA Triangle**

The RSA triangle postulates that there are three criteria for a logically good argument: (1) the premises must be acceptable, (2) the premises must be relevant to the conclusion, and (3) the premises must provide sufficient support for the conclusion. The RSA triangle implies that there should be a distinction between two types of failure for something to be a good argument. One is the irrelevance of the premises to the conclusion. The other is the insufficiency of the premises to prove the conclusion (or adequately support its acceptance). The second type of failure is essentially a failure to meet burden of proof requirement, at least according to the new dialectical approach of chapter 6.

To study the problem of drawing a distinction between irrelevance and insufficiency, we return to two textbook cases of the *ignoratio elenchi* fallacy cited in chapter 3. Hurley's two examples of the fallacy of missing the point (cases 3.23 and 3.24) are illustrated by the following pair of inferences:

(I 3.23)      Crimes of theft and robbery have been increasing at an alarming rate lately.

---

The conclusion is obvious: we must reinstate the death penalty immediately.

(I 3.24)      Abuse of the welfare system is rampant nowadays.

---

Our only alternative is to abolish the system altogether.

In case 3.23, the fallacy could be classified as a kind of *non sequitur*. Clearly, the premise is woefully inadequate as evidence for accepting the conclusion. Yet ludicrously, the conclusion uses the word *obviously*. In case 3.24, no other alternatives to the problem cited in the premise are considered. Then in the conclusion, a radical solution is said to be "our only alternative." The fallacy

here could perhaps be classified as the so-called black-and-white fallacy, also known as the “false dichotomy” fallacy. But underlying both cases is a common failure. In both cases, the inferential leap to the conclusion is premature and based on inadequate evidence.

In both cases, the problem is that the “leap” from the premise to the conclusion is too great to be sustained if all that is given in each case is the information in (I 3.23) and (I 3.24). What stands out in both cases is that there is a sudden logical leap from the premises to the conclusion. It looks like the problem is one of insufficiency of evidence given in the premises to support the conclusion.

It is a little surprising, therefore, to see Hurley categorizing the failure as one of irrelevance. Hurley (1994, p. 124) classifies both cases as instances of the fallacy of missing the point or *ignoratio elenchi*, “a special form of irrelevance” (p. 125). One can see why this diagnosis has some plausibility. Hurley wrote (p. 125) in connection with case 3.23, for example, that although other conclusions, like “We should provide increased police protection in vulnerable neighborhoods,” do follow from the premise, the conclusion actually given in case 3.23 does not. So, in a way, the fallacy is one of wrong conclusion.

Even on the dialectical theory of relevance, it appears that the inadequacies in cases 3.23 and 3.24 could be seen as failures of relevance. In terms of the new dialectical theory of relevance, if the conclusion to be proved in the case is the one cited in the argument—and this observation applies to both cases—chaining forward from the premise leaves such a huge gap that one hardly knows where to start to generate a sequence of intervening argumentation adequate to take us (by a chain of reasoned inferences) from the premise to the conclusion. The fault here seems to be mainly one in the chain of reasoning. That chain simply cannot be extrapolated forward far enough to reach the conclusion it is supposed to reach. Hence, on the new dialectical theory, it does seem plausible to categorize the failure as an instance of the fallacy of wrong conclusion.

Another way of diagnosing the problem with cases 3.23 and 3.24 is to make the following claim about them. The problem is not that you can not extrapolate forward from the premise to the conclusion. The problem is that there is simply insufficient evidence in the premise to make any attempt to prove the conclusion successful, unless new evidence is added. In both inferences, I 3.23 and I 3.24, other evidence could be added and the argument expanded so that you could get a reasonably well-supported argument for the conclusion. For example, in case 3.24, other alternatives, like trying to fix the present welfare system, may be considered and rejected, by giving evidence for rejecting this alternative. It would then be possible to extrapolate the argument forward and reach the conclusion that the only alternative is to abolish the welfare system. In other words, in both cases, there is the potential to complete

the argument to the conclusion by extrapolating it forward. By this diagnosis, the failure is one of insufficiency as opposed to being one of irrelevance.

What is wrong in Hurley's two cases of missing the point (cases 3.23 and 3.24) is that the evidence cited in the premise does not have nearly enough probative weight to support the conclusion as acceptable. But the conclusion, in each case, is advanced dialectically as though it must be acceptable to the respondent. In case 3.23, the wording "the conclusion is obvious" is used. In case 3.24, the conclusion is said to be "our only alternative." Thus, the argument uses a tactic of trying to force acceptance even though the evidence given is far from sufficient, and there is no obvious way of chaining it forward to throw much (or enough) probative weight onto the conclusion. The fallacy here is not so much one of missing the point. It could be perhaps called the logical leap fallacy, or the fallacy of trying to force acceptance of a conclusion on a basis of weak probative weight. Let's provisionally call it the logical leap fallacy for lack of a better name.

The analysis can be clarified by examining figure 7.1. The assumption is that the evidentiary basis is fixed. But if new evidence is brought into a case and the evidentiary base is expanded, that might make the argument quite different. It might change whether something is relevant or it might not. Hence the assumption of the new dialectical theory is that when relevance is judged, it is judged relative to the body of evidence at a particular point in a dialogue. Thus, a distinction needs to be made between failure of evidential sufficiency to prove a conclusion and failure of relevance relative to a given body of evidence.

#### 4. ENTHYMEMES AND RELEVANCE

Judging whether something is relevant or irrelevant in a conversation is something we often do. But what is the underlying structure of a relevance judgment? And even more importantly, how can such a judgment be carried out in a systematic logical series of steps so that an objective evaluation can be made of whether it is based on good evidence? The new dialectical hypothesis is that the methods of argument extrapolation and profile reconstruction should be used, based on the given textual evidence in a case. In a typical case, the argument is still incomplete, and many of the details of how the argumentation will go are not yet known. Some information about the goal or end state of the line of argumentation is usually given, as well as some information about the starting point or the actual argument. Typically, however, the chain of argumentation joining the one point to the other is only partly stated. For example, the kind of relevance fitting the FRE definition, which uses the notion of probative weight, is applied in the middle or beginning of a trial. The judge rules on relevance, so the decision seems to be intuitive, based partly on the rules of evidence and partly on the judge's knowledge and past experience in

trials. But on the new dialectical hypothesis, such a decision can be viewed as having an underlying structure of logical relevance. It is based on the notion of chaining the given argument forward to see if it moves toward the ultimate conclusion to be proved or cast into doubt by the trial.

This chaining forward notion of relevance is built into the method of argument extrapolation. This method is the narrower of the two. The broader notion of relevance is that modeled by profiles of dialogue. The narrower kind of relevance is estimated in a given case by applying the method of argument extrapolation. But how does this method really work? It looks basically like it is merely a mechanical operation of chaining forward by applying forms of argument to propositions given as facts in a case over and over again until you see how far the chain of argumentation can extend. Then you decide whether it can extend as far as the ultimate proposition to be proved.

However, if you examine realistic cases, as we have done, you can see that more is involved. If the case is complete and all the argumentation is on record, the applicable technique is that of the argument diagram. But anyone who has applied argument diagrams to real cases of argumentation knows that the application depends on implicit premises and conclusions. The problem here is the typical one of argument reconstruction, familiar in informal logic. The usual techniques of argument diagramming, finding missing premises, and so forth, are the methods that need to be used. How to use these techniques as part of the method of argument extrapolation has already been explained in chapter 6, section 3. *Araucaria* and its set of accompanying argumentation schemes is especially useful if the argumentation in a case is incomplete. The more difficult cases for judging relevance are not ones where the argumentation is explicit and complete, and where plenty of information is available, including a transcript of the whole debate. Rather, they are ones like cases 1.2 and 1.3, where the problem is that next to nothing about the details of the case is known or stated. It may look like the argument is going in a wrong direction, or that the arguer is using emotional rhetoric to throw us off track, but we can't really be sure. The reason is that he simply hasn't gone very far toward the ultimate thesis to be proved. He might get there eventually, but we don't know yet whether he will. It looks like he won't get any further, but how can we prove this, or support it by evidence?

What one must do, according to the new dialectical method, is to extrapolate the given argument forward, based on its known elements. The obvious comparison is with planning in AI. Planning is based on plausible conjectures about possible pathways that might reach a final goal state or not. Similarly, argument extrapolation depends on which way you conjecture the argument is likely to go, based on common knowledge about how such a line of argumentation would typically or normally go. Like planning, argument extrapolation is conjectural. Working from an initial configuration in which a problem is posed, it tries to fill in the missing steps needed to move an argument



forward and satisfy a goal condition. There can be various pathways leading to the goal and various other pathways that lead away from it.

Now let us turn to examining some examples of the fallacy that Johnson and Blair call “irrelevant reason.” In case 3.12, cited by Johnson and Blair as an example of the fallacy of irrelevant reason, the irrelevant premise given was (P1) in the argument, as represented here:

- (P1) All of the legislation in Canada isn’t going to protect a child from the normal hazards of life.
- (P2) This doll is a normal hazard of life.
- (P3) It would be inappropriate to draft legislation seeking to prevent the manufacture and sale of this type of doll.

The problem in this case was not exactly the same as that in Hurley’s cases 3.23 and 3.24, where forward chaining from the premise did not seem to produce any sequence of argumentation that would or could get from the premise to the conclusion. In these cases, the “leap” from the premises to the conclusion was too great to be sustained. By contrast, in case 3.12, there is an obvious way to justify the leap. By adding the premise (P2) we get an argument, ‘(P1), (P2); therefore (C),’ which not only appears to represent the proponent’s line of reasoning in the case, but also appears to be deductively valid, or at least to represent a form of argument that would generally be considered structurally correct. However, the problem with this line of argument is that the inserted premise, added by argument extrapolation, is false (or is implausible, based on the information given, and what is known about the case). The failure here is not because of a dialectical shift. It is a failure to extrapolate forward because of the need for an implicit premise that cannot be justified.

In case 3.12 then, the fallacy is one of misdirected argumentation because the given premise is not relevant to the conclusion, meaning, according to the new dialectical theory, that argument extrapolation from this premise to the conclusion lacks probative potential. The failure of potential occurs because the only plausible candidate for a nonexplicit premise needed to complete the extrapolation is in fact false. The argument fails for a different reason than in cases 3.23 and 3.24. In those cases, the argument was simply too weak because it was lacking in enough evidential resources, or enough of the right kind of support, to make it much or any use to prove the conclusion. In case 3.12, the argument is probatively useless because it has a false or implausible implicit premise. Because it depends on an assumption that is false, or would be extremely difficult to prove, it too is a probatively useless argument. The argument can only offer an “irrelevant reason,” lacking in probative potential to prove the conclusion that is supposed to be proved.

Now contrast these three cases (3.12, 3.23 and 3.24) with case 3.9, cited by Damer as an example of the fallacy of missing the point. In the Damer case, the argument was based on two premises.

- (P1) Americans have a great heritage built on fine ideals.
- (P2) We should all help to carry on this great heritage by passing it on to our children.
- (P3) All Americans should regularly go to church on Sunday.

As noted in the discussion of this case in chapter 3, there is no explicit connection by way of a sequence of argumentation between the premises and the conclusion, but a connection can be supplied by adding the premise, 'Going to church on Sunday is part of the American heritage'. This implicit premise is fairly plausible and could possibly represent the line of argument extrapolated from the proponent's line of reasoning (although there is no textual evidence that it does). In contrast to case 3.12, the added premise is, at any rate, not false or implausible. In contrast to cases 3.23 and 3.24, the additional line of argument needed to extrapolate from the given premises to the conclusion supposed to be proved is not difficult to fill in. A plausible candidate, easily supplied, makes the sequence of practical reasoning from the premises (supplemented by the new implicit premise) a structurally correct sequence of reasoning. So in case 3.9, it is much harder to evaluate the case by saying that it commits a fallacy of relevance (the fallacy of missing the point) than it was in cases 3.12, 3.23 and 3.24.

In case 3.9 then, it would be appropriate to raise a procedural question of the form, 'Why are the given premises supposed to be relevant to the conclusion?' But in cases 3.12, 3.23 and 3.24, a critic would be justified in going further and claiming that the fallacy of irrelevance has been committed. The reason is the failure to find any evident line of argument that could be used in an argument extrapolation to get from the given premises to the conclusion supposed to be proved. The assumption is that in all three of these cases, the example as given represents the total text of discourse—all the evidence we are given in the case. By default, the lack of any evidence of a kind that would support the required argument extrapolation justifies the evaluation that no plausible and useful line of reasoning going from the premises to the conclusion can be reconstructed from the information. Because these premises evidently cannot be used to prove or appropriately justify the conclusion, in the way required by an argument in the given case, it is reasonable to conclude that the given argument commits a fallacy of irrelevance. It actually interferes with the purpose of an argument in the type of dialogue appropriate for the case, in other words, by falling short, taking us only to a conclusion away from the one to be proved.

## 5. THE RED HERRING FALLACY

According to Johnson and Blair's analysis of the red herring fallacy, illustrated by case 3.13, the argumentation tactic characteristic of this particular fallacy is the encouraging of a "shift of focus" away from a line of argument that is needed, or would be appropriate, to prove a conclusion at issue. Johnson and Blair's case 3.13 illustrates this characteristic feature of the red herring fallacy, if interpreted a certain way. In this case, Martin was supposed to prove the conclusion that Windsor is not a grimy city. He started off by making the claim that it has one of the best flower parks in Canada. This premise is relevant. But then he added that Windsor is a city of fine schools and hard-working and tolerant people. These claims may be true, but they are not materially relevant to proving the conclusion Martin is supposed to be proving. Judging from the context of the speech, it sounds like he has gotten a little carried away. The positive features he cited in his second claim are politically and emotionally appealing to the self-esteem of citizens of Windsor, and of Canadians generally, but they do not appear to be useful as evidence to refute the thesis that Windsor is a grimy city. There could be a link between hard-working citizens and keeping a city clean, but it is a weak and somewhat dubious one.

Taking this interpretation, the fault in case 3.13 could plausibly be identified as more than just being an instance of the fallacy of missing the point. To the extent that Martin is using the appeal to the sentiments of his audience as a tactic of distraction from the real point to be proved, it could be said that the fault in this case is an instance of the red herring fallacy. To the extent that the shift of focus instigated by Martin can be seen as the use of a tactic of distraction, it is appropriate to regard the case as an instance of the use of a red herring.

There are some remaining questions about case 3.13 that are open to discussion, however. It seems from Johnson and Blair's description of the case, that Martin may not so much be using a calculated tactic of deception in his rhetoric as letting himself be carried away with his own rhetoric, engaging in what Fearnside and Holther described (chapter 3, section 3) as *pettifogging*, "with much noise and sawing of air." If so, the fallacy in this case may perhaps best be classified as a special subtype of red herring called *pettifoggery* (to be discussed in section 6 of this chapter). Another question is whether Martin's argument might be better classified as an *ad populum*, as opposed to an *ignoratio elenchi*, as he did appeal to the popular sentiments of the citizens of Windsor. Both these evaluations can be supported by evidence in case 3.13, but on balance, Johnson and Blair were justified in treating this case as an instance of the red herring fallacy, on the grounds that the central factor in it is a shift of focus that can be seen as a use of a tactic of distraction.

Hurley's cases 3.25 and 3.26 are comparable in this regard. In Hurley's own description of them (quoted, in chapter 3, section 7), the arguer changed the subject—to infant deaths and nuclear waste respectively—as part of a tactic to “entice others to pick up the new topic and begin discussing it or debating it.” To the extent that what is being used in these cases is an argumentation tactic of shifting the focus away from the conclusion to be proved onto a more exciting and emotionally provocative issue, the fallacy can rightly be judged to be one of red herring. Hurley's two examples of the red herring fallacy, said to occur when “the arguer diverts the attention of the reader or listener by changing the subject to some totally different issue” (cases 3.25 and 3.26), involve the following pair of inferences:

(I 3.25) Nestlé manufactured that terrible baby formula that resulted in the deaths of many babies in third world countries.

Taster's Choice is made by Nestlé.

---

Your friend Margie must be wrong when she says that Taster's Choice tastes better than Folgers.

(I 3.26) GE manufactures nuclear weapons that have led to tons of nuclear waste.

---

Therefore, *Consumer's Digest* is wrong when they report that GE light bulbs last longer than Sylvania bulbs.

Actually, the conclusion in Hurley's case 3.26 has GE and Sylvania the other way around, but that order seems to make less sense as an example. The fault with these two inferences, initially, seems comparable to that of the previous two. In both (I 3.25) and (I 3.26), attempting to use forward chaining to extrapolate the argument from the premise toward the conclusion seems to present no likely path of reasoning that could be used to fill the gap.

On reflection, however, a difference between this pair of cases and the previous two becomes apparent. In cases 3.25 and 3.26, the premises cited appear to be used to create a diversion by evoking disapproval for Nestlé and GE, respectively. In both cases, alleging ethical wrongdoing or bad consequences evokes an attitude of disapproval much in the way the *ad hominem* argument (and the other emotional fallacies cited in chapter 4) frequently do. The arguer's tactic evidently is to make the listeners feel such a negative emotional reaction, or sense of disapproval, that they will reject the products of this corporation. This tactic of interjecting an emotional appeal, although it does not present premises or arguments that can be chained forward in a longer sequence of argumentation that could be used to prove the

conclusion at issue, nevertheless provides a diversionary line of argument that might lead the uncritical listener to go ahead and accept the conclusion anyway. The characteristic of the argumentation used in this pair of inferences is the use of a tactic of distraction to try to divert the attention of the listener away from the probative inadequacy of the argument given.

The main difference between the misdirected argumentation fallacy of irrelevance and the red herring subtype is that in any case of misdirected argumentation, there is a failure of argument extrapolation, whereas in the case of red herring, more than this failure is involved. The failure is indicated in a given case by the lack of any plausible projected or indicated sequence of argumentation of a kind appropriate for the type of dialogue. Of course, the full story, according to the theory presented in chapter 6, is more complicated. Profiles of dialogue, and questions of local versus global relevance need to be considered and weighed in many cases. But failure of argument extrapolation is the basic and central criterion used in judging whether the fallacy of misdirected argumentation has been committed.

What is the "more" involved in the red herring fallacy? In a case of this fallacy, there will be a failure of argument extrapolation, but something else has to be present as well, in order not to be merely a case of misdirected argumentation. For the red herring fallacy to have been committed, a particular type of sophisticated tactic must have been used: the tactic of diverting a line of argument away from its proper course by providing a distracting interlude, leading away from the issue of the dialogue. Where this tactic does not centrally involve the use of an argumentation scheme identifiable with one of the other known, baptizable fallacies, for example, use of personal attack in the *ad hominem* argument, the failure of relevance in the case in question may be classified as an instance of the red herring subtype of misdirected argumentation fallacy.

## 6. DIVERSION AND PETTIFOGGERY

The solution to the problem of analyzing fallacies of irrelevance comes in two parts. One is the problem of exposing the underlying structure of a relevant argument that has probative weight. This task has now been accomplished by the new dialectical method. An argument is relevant if there is a path from the given argument, as known by its context of use and by the data of the text of discourse in the given case, to its eventual goal-state, the ultimate conclusion that should be proved. By default, an argument that fails to be relevant is irrelevant. That seems to solve the problem of fallacies of irrelevance, and it does solve the problem of logical relevance. But fallacies also have a psychological and rhetorical side. Fallacies of relevance are arguments that are not logically relevant but that seem to an audience to be relevant. Typical

examples are cases 1.2 and 1.3. The legislator's speech in case 1.2 is persuasive to his audience because it is emotionally aroused by or attached to the thesis that all the people deserve decent housing. This thesis is not relevant, but approval for it is somehow transferred to the statement that the housing bill is a good one to vote for. The prosecutor's speech in case 1.3 may seem persuasive to the jury because it is emotionally repelled by his speech about how horrible murder is. This speech is not relevant, but the jury somehow transfers its repulsion about the crime of murder to the conclusion that the defendant is guilty of murder in this case. But how does this transfer effect work? It involves deception. Until we understand how the deception is achieved, we will not really understand all that needs to be understood about fallacies of irrelevance.

The deception can be at least partly explained in some cases. In case 1.2, for example, it may be that the defendant looks bad to the jury. Perhaps he has a brooding dark face, or looks menacing or "weird." Thus when the lawyer emotes about the horribleness of murder, the jury extrapolates forward or backward, connecting up the two matters. Perhaps it goes something like this: Murder is a horrible crime, and only a "weird" or anti-social person could commit such a crime; therefore, the defendant plausibly or possibly committed this murder. Of course, examined as an extrapolation forward, this line of argumentation is full of questionable gaps. After all, some murderers look quite normal, and some people who look "weird" or anti-social are not murderers. But juries, like all of us, are often influenced by a person's personal appearance. They tend to be very reluctant to convict a person who is attractive and who appears to have pleasing social qualities. They can be quick to convict someone who is a loner, or who appears unusual, or does not appear to have social qualities. This factor of how a person appears to a jury has been the explanation of many cases of unjust conviction where it is a puzzle why a jury would convict a defendant on the basis of so little real evidence.

Some of the other cases studied are somewhat problematic when it comes to classifying them exactly as instances of the missing the point subtype or the red herring subtype. In case 1.2, the senator argues only that decent housing for the people is desirable. This case is partly one of misdirected argumentation because it is problematic to see how the senator is going to use his line of argument to show that the proposal for housing legislation is a good one. But the senator's argument also seems to be a red herring, to the extent that it involves the use of an *ad populum* tactic of rhetorical diversion that appeals to sentiments that would presumably be popular with voters. Similarly, in case 1.3, the lawyer's argument about the horribleness of murder has been criticized on our analysis because it is an instance of misdirected argumentation. It may also function as a diversion by getting the jury to turn to the horrible aspects of murder, and by an emotional transfer condemn the person who is alleged to have committed this crime. In these cases, we can see elements of both the misdirected argumentation and of the red herring fallacies, suggesting that the

red herring fallacy can be seen as a kind of extension of the misdirected argumentation fallacy. In this extended fallacy, not only is capability of proving the thesis missing, but there is a diversion to some other topic or argument as well.

Another complicating factor is that there seem to be two subtypes of the red herring fallacy. In one type of case, there is a very definite diversion to some other issue or line of argument, a pressing forward of this other line of argument as a distraction, and a way of putting an opponent on the defensive. In the other type of case, it seems more like the arguer is pontificating or blundering around on some abstract or theoretical issue, and the intervention is more of an aimless diversion than a focused attempt to divert to another definite and sharp line of argument. In case 1.2, as described by Copi, it appears that the senator is merely pontificating, or introducing gaseous clouds of vaguely popular rhetoric, by arguing for the vacuous conclusion that decent housing for all the people is desirable. The difference between these two kinds of cases seems to come close to the substance of Fearnside and Holther's distinction between the two fallacies they called *diversion* and *red herring*. According to their account (chapter 3, section 3), the fallacy of diversion occurs where a speaker leads discussion away from the issue by directing it to some other exciting issue. The red herring fallacy, on their account, occurs where the speaker "pettifogs," "loses all sense of proportion," and talks "of anything except the issue, at great length, with much noise and sawing of air." This way of characterizing the difference between these two kinds of cases seems to correspond fairly well to the distinction drawn between the two subtypes of what we have been calling the *red herring fallacy*.

The immediate problem, then, is one of terminology. To contrast the wrong conclusion subtype with the other subtype, it seems best to call the other one the red herring fallacy. But then, going in the direction of Fearnside and Holther's nomenclature, the two subtypes of this general type could be called the *diversionary* type of red herring and the *pettifogging* (or *pettifoggery*) type of red herring. The pettifogging type could be characterized, in the words of Fearnside and Holther, as "making much of little," and "talking of anything except the issue, at great length." The strategy here seems to be a dissipation of the proper line of argument by making it disappear into a gaseous fog of rhetoric. One characteristic of pettifogging is an inappropriately high level of abstraction, resulting in a failure of material relevance. The diversionary type of red herring tactic is characterized by a sharp and more distinctly laid out attack along a different line of argument than the one that should move by a line of reasoning towards the real issue. All these subtypes will be summarized in the classification scheme presented in section 10 of this chapter.

## 7. THE SEPARATION PROBLEM

The main problem in defining fallacious irrelevance as a clear and distinct fallacy in its own right is that of separating it off from other fallacies that seem also to be fallacies of relevance. Aristotle was, of course, quite aware of this problem, as noted in chapter 4, when he classified all fallacies not dependent on language as instances of misconception of refutation. However, the problem was magnified, and even rendered intractable, by the loss of the Greek dialectical framework of argument in the subsequent development of logic as a discipline. As noted in chapter 3, *relevance* was a term still in use in the classification and evaluation of fallacies in the logic textbooks. But it was a term that had lost all coherent meaning in logic. Hence, it became, in many textbooks, a wastebasket category used to condemn arguments in cases where no real explanation of why they are wrong could be given.

In particular, certain arguments that have to do with particularly powerful kinds of appeals to emotion—especially the *ad hominem*, *ad baculum*, *ad misericordiam*, and *ad populum* fallacies—were classified routinely as fallacies when or if they were used as distractions, as irrelevant moves in argument distracting an opponent or audience from the real issue of a conversational exchange. Also, as noted in many instances in chapter 3, the textbook treatments strongly identified the straw man fallacy as being the same as, or similar to, or perhaps a leading subspecies of the *ignoratio elenchi* fallacy. Some textbooks even went as far as Aristotle and classified all the fallacies not dependent on language as essentially fallacies of irrelevance. Others cited a smaller subset, often emphasizing the five fallacies just mentioned as being the fallacies of irrelevance.

The general problem is one of where to draw the line. Is misdirected argumentation a separate fallacy in its own right, or is it also, at least partly, involved in these other fallacies? Or is the misdirected argumentation really a master fallacy that underlies all the other fallacies dependent on language, or some special subset of them, so that all these fallacies are really special cases or subfallacies of relevance? The solution advocated here, in line with the theory of relevance presented in chapter 6, is to classify an argument or move in argument that exhibits a failure of relevance in a given case as an instance of the misdirected argumentation fallacy, as opposed to classifying it as, say, an *ad hominem* or *ad baculum* (or other particular type of fallacy where relevance is involved), if none of these other characteristic argumentation schemes are primarily involved in the failure of relevance. Thus, an argument or move in argument will be classified as a misdirected argumentation fallacy partly by default. It is a misdirected argumentation if failure of relevance is the basis of the fallacy and if the argument or move in argument fails to fit into one of the other established categories of fallacy, like the *ad hominem* or *ad baculum*.



This default type of analysis makes fallacious irrelevance a derivative fallacy, based on other established types of fallacy already in place. It also sets a particular standard for classifying fallacies because, on this account, several of the other fallacies will turn out to be, at least partly (and to a greater or lesser extent) fallacies of relevance. However, it does not have the consequence any more that irrelevance is a wastebasket category (at least in the bad sense) because relevance has been clearly defined by the theory of chapter 6. Dialectical irrelevance is always a failure of argumentation to chain forward, by the method of argument extrapolation (or by the method of profile evaluation) to reach the conclusion supposed to be proved in the type of dialogue appropriate for the case. Essentially, irrelevance is always a failure to meet requirement (*R5*) of the persuasion type of dialogue (chapter 5, section 1), which stipulates that the chain of argumentation used in a case by a proponent must have the proponent's designated thesis as its (ultimate) conclusion. But this requirement (*R5*) is not just characteristic of the persuasion dialogue. It is a normative requirement of all six basic types of dialogue studied in chapter 5, except the eristic type of dialogue. And *ignoratio elenchi* as a failure of relevance is always a failure to meet (*R5*). So the theory of relevance in chapter 6 clearly defines the core nature of *ignoratio elenchi*. Moreover, the methods of case evaluation developed in chapter 6 give objective techniques, supported by evidence, to determine when dialectical irrelevance is a fault of argument, from a normative point of view. Finally, argumentation schemes for the *ad hominem*, *ad baculum*, and other fallacies that are partly failures of relevance, have now been presented in Kienpointner (1992) and in Walton (*Arg. Schemes*, 1996). So clear criteria are available to determine whether an argument used in a given case is an *ad hominem* argument, an *ad baculum* argument, or whatever, as opposed to being a pure fallacy of irrelevance.

What you need to do, in order to evaluate an *ad hominem*, *ad misericordiam*, *ad baculum* or *ad populum* argument (and this applies to other types of argumentation as well) is first of all, test it to see if it meets the requirements (of the argumentation scheme) for that type of argument. Let's suppose that it does. Then test it for relevance. How do you do that? According to the new dialectical theory, you use the combined method of argument chaining and the profile of dialogue. If a dialectical shift is involved, then you will have to evaluate the case to see if a dialectical embedding exists or not. Many cases of the fallacy of misdirected argumentation, in its various forms, occur because a dialectical shift makes argument extrapolation to the proper conclusion impossible.

## 8. AD HOMINEM ARGUMENTS AND IRRELEVANCE

The four emotional fallacies introduced in chapter 6—the *ad hominem*, the *ad baculum*, the *ad misericordiam*, and the *ad populum*—are all clearly definable as distinctive fallacies because they are instances of certain argumentation schemes. For example, the *ad hominem* argument is basically a use of personal attack, where one party in a dialogue exchange argues against the argument of another party by saying to the audience, “He is a bad person (meaning he has a bad character, in some respect); therefore, you should not accept his argument.” The *ad hominem* argument depends on a link or warrant to the effect that if someone is a bad person, he lacks personal credibility, and therefore because the acceptability of his argument depends on his personal credibility, his argument ought to be rejected (or at least brought into doubt).<sup>1</sup> This link or warrant leads to the conclusion of the argumentation scheme for the *ad hominem* argument, namely, that this person’s argument ought to be rejected.

So wherever it was used, the *ad hominem* argument can be evaluated in light of the argumentation scheme just outlined. Critical questions matching the scheme can be asked. For example, it can be asked whether the party attacked really is a bad person (according to the evidence available, or as represented by the other party). Another critical question is whether the *ad hominem* argument, even if its premises are adequately supported by the proponent, is relevant (in the context of dialogue appropriate for the case).

In chapter 6, section 8, it was shown that the way to analyze *ad hominem* argumentation is to use the concept of an agent in multi-agent systems of dialogue. An agent is seen as having characteristics like reliability and honesty that are important factors in judging that agent’s credibility in a dialogue. A good example can be found in legal argumentation. Suppose that a lawyer is cross-examining a witness in court, and she attacks the credibility of the witness, arguing that the witness has lied in the past and has shown a bad character for veracity. Such an *ad hominem* attack, could be allowed as relevant, according to the FRE, as shown in chapter 1. But if such an attack could be judged relevant in a trial, how could such a judgment of relevance be proved to be reasonable, according to the new dialectal theory of relevance? The answer lies in evaluating how the argument was used in the context of dialogue concerned. Legal argumentation in a trial, as will be shown in chapter 8, is basically a type of persuasion dialogue in which each of the counsels for the opposed sides tries to persuade the trier that he or she has the argument that meets the requirement for burden of proof. Thus it seems that the *ad hominem* attack on the witness needs to be evaluated in the context of such a persuasion dialogue.

However, the case is not this simple because the examination of the witness is best seen dialectically as an examination dialogue, that is, a species of

---

<sup>1</sup> See Walton (*Arg. Schemes*, 1996, pp. 55-61 and pp. 85-87).

information-seeking dialogue. In other words, there has been a shift from a persuasion dialogue to an information-seeking dialogue. Such a shift is normal in a trial. It represents the normal embedding of an information-seeking dialogue in a persuasion dialogue. Therefore, in that context, the *ad hominem* argument used to attack the credibility of the witness can be dialectically relevant. Even if relevant, of course, such an *ad hominem* argument could still be fallacious, depending on how the cross-examiner put it forward. Suppose, for example, she tried to intimidate the witness by using suggestion and innuendo instead of presenting hard evidence that that witness lied in a specific case. Irrelevance is only one fault of an *ad hominem* argument. There can be other faults as well.

But relevance is one important factor in judging whether an argument of one of these four types is fallacious or not. An *ad hominem* argument, for example, could be a good argument, well supported by evidence, and meet all the (other) requirements of the argumentation scheme for *ad hominem* arguments, and yet it might still fail to be relevant. Evaluating an *ad hominem* argument requires, in addition to evaluating the particulars of the argumentation scheme as used in a given case, an evaluation of the relevance of the *ad hominem* argument in a context of dialogue. Hence it follows that the *ad hominem* fallacy is partly (but not exclusively, or in all cases) a failure of relevance. A comparable analysis can be given of the other appeals to emotion—the *ad baculum*, *ad misericordiam*, and *ad populum* arguments. When fallacious, these faults are partly fallacies of relevance, meaning that failure of relevance is one characteristic and important fault that makes them fallacious (in some cases). But it is not the only fault that can make them fallacious. In some cases, an *ad hominem* argument can be relevant, but still be fallacious. For example, in the legal type of case cited above, or in an election campaign, an attack on the person's character for veracity (say) could be relevant. Yet, in such a case, the personal attack could be so unwarranted by the evidence, and pursued with such a dogmatic and vicious zeal, that it could rightly be evaluated as fallacious. It could be fallacious because it interferes with the dialogue the participants are supposed to be engaged in, even though the *ad hominem* argument is relevant as used in this type of dialogue.

## 9. IRRELEVANCE, FALLACIES, AND SHIFTS

The relationship of the four emotional fallacies to irrelevance is contextual because the argument can work in different ways in different cases. Sometimes, for example, an *ad hominem* is fallacious simply because personal attack is irrelevant in the dialogue. Thus, attacking a rival's character in a seminar on theoretical physics would simply be inappropriate. But in other cases, for example, in political debating in an election campaign, the character issue could

be relevant although a bitter and protracted use of negative personal attack could be a red herring tactic to evade proper discussion of more important issues that should be debated. Here, what began as a relevant *ad hominem* argument turned into an irrelevant one when the attacker persisted beyond reason by improperly avoiding critical questions and issues that needed to be discussed.

In many cases, as recognized in chapter 5, an argument that could, in a certain context of dialogue, be quite reasonably used, becomes fallacious in virtue of a dialectical shift. In such cases, it may in fact be the disguised or nonevident shift from one type of dialogue to the other that makes the argument deceptively seem to be reasonable. In this type of case, the requirements for the argumentation scheme may be met reasonably enough, when the argument occurred in the first context of dialogue. Only after the shift is taken into account can the argument properly be judged to be irrelevant.

The *ad baculum* is an interesting fallacy because it is not necessarily irrelevance that makes it a fallacy. Although, as previously noted, *ad baculum* arguments can be somewhat softened, or made to appear less inappropriate by a dialectical shift, in many cases the *ad baculum* argument can work very well as a fallacy even if it is obviously irrelevant. Curiously enough, in this kind of case the fallacy also works, or is an effective strategy, because of a kind of shift.

Suppose two parties are having a critical discussion on an issue when one issues a threat to the other, in the form, "You had better accept what I say if you know what's good for you!" The second party might recognize this argument as expressing a credible threat, because he knows that the first party is in a position to harm him, and is willing to do so. But in such a case, the making of a threat is irrelevant in the sense that it is clearly an inappropriate type of move in the critical discussion—an argument that makes no contribution to the resolution of the conflict of opinion by rational argumentation of the kind that is useful and appropriate in a critical discussion.

But note that if the second party is influenced by the threat, and on grounds of prudence and safety, discontinues his expressed disagreements with what the first party says, then there has been a kind of dialectical shift involved. The context of dialogue in which the argument is being considered has shifted from a critical discussion to a deliberation. The first party issued a threat and the second party reacted by taking what he concluded was a prudent course of action in these circumstances.

The *ad baculum* argument in this case could be quite effective and powerful as an argument, even though the respondent (and everyone involved) clearly recognizes that it is irrelevant from the point of view of the critical discussion. So in this kind of case, the *ad baculum* is not a fallacy of relevance, at least not straightforwardly so, in the sense that some other fallacies are fallacies of relevance. For this case is not one where the fallacious argument appears to be relevant, but is not. It is a case where everyone involved sees that it is irrelevant, but it works as an effective argument anyway.

In such a case, then, there has been a failure of relevance in the *ad baculum* argument because of the dialectical shift. The fallacy is not one of irrelevance, or is not exclusively so at any rate, because it is not the irrelevance that deceives the respondent into accepting the *ad baculum* appeal and taking the action the proponent wants him to take. The *ad baculum* argument is not working through a deception. It works by appealing to the interests of the respondent—his concern for his personal safety. So in some cases where the *ad baculum* fallacy involves a failure of relevance, it is not this failure that explains exactly how the appeal works as an effective device for gaining compliance.

*Ad misericordiam* arguments often involve subtle dialectical shifts. For example, in one of the kinds of cases of the *ad misericordiam* cited in logic textbooks, a student who has failed his exam argues to his professor, “If I fail this course, I won’t get my degree, and as a result, I will be deported. When I return home I will be in disgrace, and may be shot!” The professor may be quite sympathetic, but she has to try to argue that her job is to evaluate the student’s exam on its merits and that she can’t give extra marks unless the work on the exam meets required academic standards. What the student has done, in making this appeal to pity, is to shift the discussion from one about the merits of his academic performance to one about the consequences of his failure in the exam. The latter discussion is not really relevant to the former one. The one dialogue is not functionally embedded in the other. Hence, the *ad misericordiam* appeal is irrelevant to the prior discussion of whether the marks on the exam should be changed.

Thus, evaluating the relevance of an *ad misericordiam* argument depends on the context of dialogue, according to the new dialectical theory. In a legal case, for example, a plea for mercy to a judge may be relevant at the sentencing stage but irrelevant in the middle of a criminal trial. For the trial is a persuasion dialogue in which the issue is whether or not the defendant committed the crime as alleged. The new dialectical theory, therefore, is the best way of evaluating fallacious relevance in the kinds of cases cited in chapters 1 and 3.

## 10. SUMMARY OF THE NEW THEORY

The central fallacy of irrelevance, according to the new dialectical theory, occurs where argument extrapolation leads away from the conclusion to be proved or settled in a dialogue, so that there is no pathway to proving or settling that conclusion. On one interpretation, Aristotle’s analysis of the *ignoratio elenchi* fallacy seems to be the same as that of the new dialectical theory, except that it is expressed in terms of Aristotle’s theory of the syllogism. Aristotle wrote that when a stated argument is a (syllogistic) demonstration, it will commit the *ignoratio elenchi* fallacy if it is “something other than that leading to the conclusion.” In other words, it could be a valid syllogistic argument that

leads to some conclusion other than the one to be proved. This account of the fallacy is expressed in terms of Aristotle's deductive theory of the syllogism as an account of demonstration (proof). The new dialectical theory is not restricted to syllogistic argumentation. Instead, it is expressed in a framework in which a sequence of argumentation is represented by an argument diagram. Consideration of probabilistic and plausibilistic arguments should be included, as well as deductive arguments. Yet despite this difference, the Aristotelian theory, as expressed above, may seem to be very close to, or even the same as the new dialectical theory. The difference appears when the Aristotelian theory is interpreted the way it has been in Western logic—as saying that *ignoratio elenchi* is proving the wrong conclusion, meaning a conclusion that is different from (but appears similar to) the one to be proved. According to this traditional interpretation of the Aristotelian *ignoratio elenchi* fallacy, the fallacious argument proves a conclusion that is not identical (or equivalent) to the one that should be proved. This analysis implies a specific proposition that fails to be identical to the conclusion to be proved, whereas the new dialectical theory does not require the existence of such a proposition for the central fallacy of relevance to be committed.

The central fallacy can be explained by referring to figure 7.1. Any argument in an actual case is based on the evidence that is given in the case. This evidence is expressed in the premises of the argument. But the evidence is not always explicitly expressed in the stated premises. The context of the argument is important, as noted so often in previous chapters. Also, in cases of arguments with missing premises, or so-called enthymemes, implicit premises may have to be contextually inferred in a case. At any rate, as well as having an evidentiary base, an argument must also have a conclusion, representing the supposed end state of the sequence of argumentation used to throw probative weight on that conclusion. The purpose of an argument is to use the evidentiary basis to throw probative weight on a specific proposition designated in advance as the proposition to be proved, settled, or cast into doubt by the argument in a given type of dialogue. If an argument fails to achieve this goal, because it is too weak, for example, that failure is not necessarily fallacious. There is a difference between committing a fallacy and using an argument that is weak, lacks probative force, or fails to fulfill a burden of proof. But if an argument fails to extrapolate forward, so that it leads away from the conclusion to be proved, and it can be judged that there is no pathway to that conclusion, then that is a kind of failure associated with the central fallacy of irrelevance.

The account given so far is not the whole story of the fallacy. A fallacy is not just an argument that is logically incorrect. It is one that has an appearance of correctness. That is, it is a deceptive tactic used to unfairly get the best of a speech partner in a dialogue. According to the theory presented in Walton (*Prag. Theory*, 1995, p. 255), a fallacy is an argument (or something that purports to be an argument, or has a place in argument) that blocks or impedes

the goal of a dialogue in which the argument was used. Also (p. 255), a fallacy is a kind of move in a dialogue that can be deceptive. It is a serious kind of error or clever tactic of argumentation that has a strong potential to be deceptive. Two types of fallacies are identified (p. 257). Errors of reasoning (*paralogisms*) are faults in reasoning relating to forms of inference. These forms can be deductive or inductive, or they can be faulty uses of presumptive argumentation schemes of the kind outlined in Walton (*Arg. Schemes*, 1996). Sophisms are argumentation tactics used by one participant in a dialogue to deceptively get the best of another participant. Sophisms are revealed by examining a profile of dialogue in relation to an ideal sequence of moves that would be appropriate or reasonable in the type of dialogue supposedly engaged in. Sophisms can also be identified with the misuse of argumentation schemes. But the fault to be evaluated is less directly related to the local failure to fulfill some requirement of a scheme than to a failure of a more global nature that requires considering evidence from an extended sequence of argumentation exchanges in a dialogue.

Now we come to an important question. Why does arguing to the wrong conclusion sometimes seem to be correct as an argument? In other words, what is the explanation of its *apparentia* as a fallacy? To answer this question, it is necessary to examine the sophistical tactics used in the various cases of the fallacy.

What distinguishes the red herring subtype of the central fallacy of irrelevance is the extrapolation toward rhetoric that is exciting and distracting to the respondent in a dialogue. In such cases, no specific “wrong conclusion” is required. Pettifoggery can be a gaseous cloud of rhetoric that is highly vague. The term *red herring* also applies to tactics of diversion like those used in the Taster’s Choice and Sylvania light bulb cases (cases 3.25 and 3.26) and is also appropriate. The tactic here is one of distraction by diversion. Yes, the argument is weak, as in the prior two cases of the logical leap fallacy. But the tactic used is distinctively different. The tactic is to pick a premise or evidentiary basis that is weak, but is sufficiently inflammatory that it may distract the attention of the audience away from the weakness of the argument.

In other cases, the explanation of the *apparentia* of the fallacy is the dialectical shift that has occurred during the sequence of argumentation. Instead of chaining forward toward proving the conclusion to be proved in dialogue type  $D_1$ , the argumentation has shifted to a different type of dialogue  $D_2$ . If  $D_2$  is embedded in  $D_1$ , the shift would be licit. Thus, even though a shift has occurred, the argumentation could still be chaining forward toward proving the appropriate conclusion to be proved in  $D_1$ . But if no embedding exists and the shift is illicit, then the line of argumentation could be leading away from proving that conclusion and could have no chance of ever proving it. A dialectical shift of this illicit sort can often be the *apparentia* for a fallacy of irrelevance.

To identify a fallacy of irrelevance in any given case, the first job is to identify the central fallacy of irrelevance. Then the case can be further examined to see if one of the subtypes is also indicated, as depicted in figure 7.4:

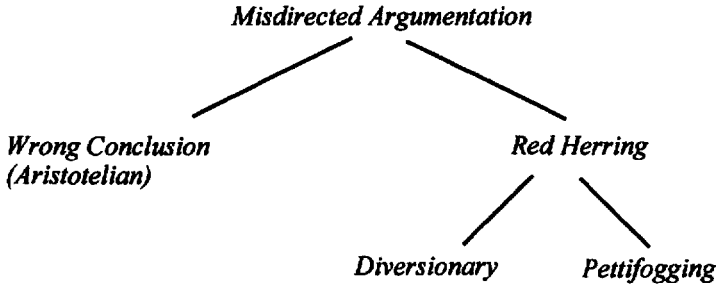

**Figure 7.4:** Classification of Fallacies of Irrelevance

The other criterion for the identification of an instance of a fallacy of irrelevance is negative or exclusionary in nature. *Ad hominem*, *ad baculum*, *ad misericordiam*, and *ad populum* arguments, in particular, are often rightly judged to be fallacious as used in a given case on the ground that the argument, as used in the case, shows evidence of one of the above kinds of failures of relevance that would be consistent with judging the case as a fallacious use of argument. These kinds of cases are said to be instances of fallacies on a basis of failure of relevance (although relevance is not the only reason these arguments can fail, or rightly be evaluated as fallacious). Here then, the separation problem is solved by the new dialectical theory.

However, one needs a careful reminder once again to note that failure of relevance is not always fallacious, on the new dialectical theory advocated in this book. If an argument or move in argument is perceived as being irrelevant, the proponent can be questioned with regard to its relevance by asking, ‘How is this move (argument) relevant?’ The proponent could then respond by sketching out an extended and projected line of argument that would indicate the relevance of the move (argument) by showing its functional place in this line of argument. In such a case, a procedural question of relevance is asked by one party in a dialogue exchange and then answered appropriately by the other party.

The case where a fallacy of relevance has been committed by one party is different from the scenario above. In the misdirected argumentation type of case, the proponent either does not reply appropriately to such a procedural question, or cannot, because such an argument extrapolation is impossible, or implausible, given what is known from the text of discourse. Or, even worse, the proponent has used an argumentation tactic to evade or deflect the answering of



such a procedural question. For example, in the case of the red herring type of fallacy, the arguer shows a pattern of diverting the line of argument elsewhere, or of pettifogging, to cover up for his failure to move his argument along a line that would make it probatively useful with respect to the goal of a dialogue.

In chapter 6, section 10, it was explained why, in many cases, it is better to evaluate a case by making a procedural charge of irrelevance that leaves a way open for the proponent to reply to the charge other than by absolutely claiming that the proponent has committed a fallacy of irrelevance. The reasons given in chapter 6, section 10, to support this recommendation, were multiple. For one thing, the claim that someone has committed a fallacy is, and should be regarded as a serious charge that implies that the argument in question has an underlying fault that may be difficult or impossible to repair without giving up the argument. For another thing, irrelevance is typically a provisional charge that has to do with the line of argument that might or could be taken in a case (among several possible alternatives, in some cases). Hence, it may be difficult or even impossible to say, in many cases, that a proponent's move or argument is absolutely or irredeemably irrelevant. The person alleged to have committed a fallacy of irrelevance may, as we found in several instances, be able to find a line of argument to join up his move or argument to the issue of the dialogue.

Accordingly then, there is a general problem in evaluating cases of the kind studied in previous chapters. When is the failure of relevance so bad that we can rightly evaluate a case as one where a fallacy of irrelevance has been committed, rather than one where only a procedural question should be raised about the relevance of the move or argument? Where is the borderline between fallacious and merely questionable cases of irrelevance, and what criterion should be used to make this distinction?

To make this distinction in a given case, what you need to do is to look for certain patterns in the argument extrapolation or profile of dialogue reconstructed from that case. To identify an instance of the red herring type of fallacy, you need to look for evidence of the use of diversionary tactics of argumentation to shift the focus of the argument to a different issue. One characteristic of diversion to look for is a pattern of repeated attempts to steer the line of argument away from the given issue and towards a different issue, often a powerfully distracting one for the audience, or a vehicle for attacking the opponent in a stimulating or threatening way.

Another characteristic to note is the pattern of response when a procedural question of relevance is raised. Does the proponent give plausible indications or evidence of a line of argument he is taking or will take that will really contribute to the dialogue he is supposed to be taking part in? Or does he insist on some connection that is merely adventitious, and is a mere excuse for relevance, for example, a line of argument that is not materially relevant to the issue of the dialogue to which his argument is supposed to contribute?

In some of the cases examined, there was plenty of evidence of this kind from the text of discourse in the case that would justify the charge that the arguer committed a red herring fallacy, rather than judging the case as a mere blunder, or as a failure of relevance that could easily be repaired by raising a procedural question of relevance. Whereas in many other cases—for example case 3.9—the failure of relevance was of a kind that could easily be repaired and would indicate only the posing of a procedural question on whether the argument in question is relevant.

A final note about the fallacy of wrong conclusion. For this Aristotelian fallacy to be committed, it should not be enough, by itself, that the given argument arrives at a different conclusion from the one to be proved. For as indicated in figure 7.1, the pathway for potential completion of the argument has to be considered. Only if the two propositions (the actual conclusion and the one to be proved) are different in the following sense has the fallacy of wrong conclusion been committed. The pathway for potential completion from the actual conclusion to the conclusion to be proved has to be such that argument extrapolation from the one to the other cannot be achieved. In a fallacious case, the evidentiary base is such that there is no feasible way to extrapolate the argument forward from one conclusion to the other.

The solution to the problem of separating fallacies advocated in this chapter is to define the special fallacies of irrelevance by default. If the failure is purely one of relevance, that is, if it is not the case that the argument in question is an *ad hominem*, an *ad baculum*, an *ad misericordiam*, an *ad populum*, or one of the other baptizable types of arguments associated with a known fallacy, then it comes under the heading of the *ignoratio elenchi* fallacy. Thus, in a way, the theory advocated here could be criticized for perpetuating the “wastebasket” approach to the *ignoratio elenchi* set in place by Aristotle.<sup>2</sup> However, in defense of the new dialectical theory of fallacious irrelevance, it can be said that such fallacies are no longer based on an undefined concept of irrelevance. Far from it, for the concept of dialectical relevance has been clearly defined in a theory of normative models of dialogue, and it has now been shown how the theory can be applied to evaluating relevance in particular cases. When it is claimed that an argument or move in an argument is irrelevant in a given case, we know exactly what that means and how to evaluate the claim by citing specific evidence that counts for or against it. So whether the argument is classified as a fallacy of irrelevance, or identified as some more specific type of argument that has been used fallaciously on grounds of irrelevance, the underlying basis of the objection to it as a failure of relevance can be understood clearly and evaluated objectively.

---

<sup>2</sup> Particularly in cases where pettifoggery is involved, like the Windsor case, the decent housing case, and the train case, it may be open to discussion whether, on balance, it is best to classify the case as an *ignoratio elenchi*, or place it under the heading of one of the other fallacies like *ad populum* or *ad misericordiam*.

Thus, in the end, Aristotle's account of the *ignoratio elenchi* fallacy, or at least something along the general lines laid out by Aristotle's account in *On Sophistical Refutations*, has been supported by the new theory of dialectical relevance advocated in this book. The problem with Aristotle's account of the fallacy is not that it is inherently wrong, but that, since the disappearance of Aristotelian dialectic from logic as a framework for the reasoned evaluation of argumentation, the resources for making sense of his account of this fallacy (or of any of the informal fallacies) have been absent. The resulting conceptual disarray has impoverished logic as a discipline that can be applied fruitfully and successfully to realistic cases of arguments in everyday conversations. This highly significant gap is filled by the new dialectical theory of fallacies of irrelevance.

## Relevance in Legal Argumentation and Political Debate

Some of the examples of irrelevance cited in chapters 1, 2, and 3 presented a special problem because they involved an institutional framework containing rules of relevance. Some were legal arguments. As noted in chapter 1, the FRE sets down rules of relevance that must be followed in a trial in Anglo-American law. Others were arguments from legislative debates, governed by rules of order, maintained by the Speaker of the House. In such debates, there are institutional requirements that govern who can speak and what they can say. There are even rules of relevance in the rules of order. As students or practitioners of logic, or argumentation theory, we are not necessarily in a position to know such rules, or be expected to apply them, when we evaluate an argument for relevance. On the other hand, the logic textbooks intend relevance to be applicable precisely to these kinds of cases of political deliberation and debate. It is clearly a big asset of any theory of relevance that it is at least potentially applicable to such cases.

Relevance is much more tightly enforced in a trial than in a political debate. Beginning with a brief sketch of rules of relevance in the Canadian House of Commons Debates, chapter 8 outlines in more detail how relevance is dealt with in evidence law. The basic problem of the relationship between logical relevance and legal relevance cannot be solved in a single chapter, nor can all the many complex aspects of the subtle relationship between these two concepts be identified in a single chapter. What can be done is to open up a new way of studying legal relevance by seeing its dependence on an underlying concept of logical relevance. The outcome is to open up a new and much more revealing method of modeling the structure of relevance underlying the law of evidence than has been possible in the past.

### 1. RELEVANCE RULES IN THE CANADIAN HOUSE OF COMMONS

Any judgment on the relevance of a speech in a political debate depends very much on the stage of the discussion that speech occurs in. In debates in the Canadian House of Commons, there can be different contexts in which discussion of the same bill or issue can arise. The kind of discussion that might take place in Question Period, for example, could be very different from what

takes place in the second reading of a bill, where wide-ranging debate on the principle of the bill is appropriate and long speeches are permitted.<sup>1</sup>

A bill normally goes through several stages of discussion in parliamentary debate, and relevance has to be judged in a different manner at each stage. During the second reading of the bill, “where debate is limited to the principle of the bill, debate on individual clauses is out of order” (*Précis of Procedure*, 1987, p. 78). But if an amendment is proposed, it must be relevant to the main motion (p. 77), and at the amending legislation stage, “debate which touches on parts of the Act other than those affected by the proposed legislation” are ruled “out of order” (p. 78). At the report stage, the kind of wide-ranging discussion typical of the initial reading stage is ruled irrelevant (p. 78). And finally, “at third reading, although lengthy debate here is rare, debate is irrelevant that is not strictly confined to the contents of the bill” (p. 78). At the third reading, amendment is still permissible, “with the restriction that no new matter not in the bill may be proposed” (p. 78). At the so-called first reading, a bill is merely tabled for discussion, that is, made available for discussion. It is during the second reading that the general debate on the principles of the bill should take place. Following this stage, discussion centers on proposals for amendments prior to the bill’s going to a vote. Thus, relevance in a political debate is very much affected by the stage of discussion that a particular bill has reached.

The rules of debate for the Canadian House of Commons are outlined in *Beauchesne’s Rules and Forms of the House of Commons of Canada* (usually called *Beauchesne*, for short) (Fraser, Birch, and Dawson, 1978, pp. 97-120). According to *Beauchesne* (p. 97), the process of debate arises out of several factors. These can serve to define the process of what constitutes a parliamentary debate, generally. First, a Member rises to put forward a motion. Second, the Speaker of the House determines that this ascertains, or calls for a debate. Third, a discussion normally ensues between the proposing (opening stage) of the debate and the putting of the question (closing stage), where a vote on the motion is called for by the Speaker. Fourth, the “question is put” by the Speaker, and then “fully put” when the vote is called for. A debate in the House of Commons often is on the subject of a particular bill that has been brought forward for approval. The bill is the “main question” of the debate. During the debate, a Member can ask a question, make a contribution to the debate, or raise a point of order. A point of order is appropriate if a Member observes a violation of any of the rules. The Member is supposed to explain the nature of the violation, and the Speaker is supposed to give a decision on the point of

---

<sup>1</sup> The proper venue in the Canadian House of Commons for opposition ministers to ask probing questions on matters of controversy, or of concern to the Canadian public, is the (oral) Question Period. The purpose of Question Period is to allow the opposition to ask the government officials responsible for a particular sector for information, or to press for action, on matters of current concern to the public.

order, The time allotted for discussion on a particular bill is limited. In order for both sides of the question to be fairly represented and to get a proper debate involving both sides of the issue, it is important to discourage irrelevance and unnecessary repetition. The rule of relevance is a special kind of point of order that a Member or the Speaker can raise when another Member appears to be getting away from discussion of the motion, bill, or question that is supposed to be the subject. The *Précis of Procedure (House of Commons: Canada, 1987, p. 77)* expresses the basic principle behind the rule of relevance as follows:

The rule of relevance may be applied when a Member's remarks do not adhere as closely as possible to the question before the House. In general, a Member's remarks are irrelevant if their connection to the main question is not immediately apparent; or if, having called a Member to order for straying from the question, the Speaker is still not satisfied with the Member's explanation of the relationship; or if what the Member has raised might properly form by itself the subject of a substantive motion.

Although the principle behind relevance and the practical need for a rule of relevance are clearly important and useful, even vital, in supporting adequate and reasonable debate in parliament, defining relevance and enforcing it in practice are problematic.

When it comes to defining relevance, only one short clause (§299) containing two sentences is to be found in *Beauchesne* (p. 98). This clause backs away from even attempting a definition, leaving everything up to the Speaker's discretion.

§299 (1) Relevancy is not easy to define. In borderline cases the Member should be given the benefit of the doubt.

Defining relevance is left wide open here. No real criterion is given to the Speaker. He is given no specific directions or guidance on how to define relevance, much less on how to prohibit irrelevance in a debate.

The only guideline given concerns the burden of proof in a procedural dispute about relevance. The Member—the parliamentarian accused of irrelevance—“should be given the benefit of the doubt.” This ruling is not very helpful for the Speaker of the House, who has to try to contend with a Member who launches into emotional rhetoric or changes the issue to another topic.

One can certainly appreciate the problems inherent in trying to define and apply a concept of relevance that will be truly helpful in supporting the goals of discussion in parliamentary debate. Too tight a restriction on relevance could overly inhibit a parliamentarian needing the latitude to develop a deep and comprehensive argument on a broad issue that may affect many people and have

wide-ranging consequences. This problem is noted in the *Précis of Procedure* (1987, p. 76):

Irrelevance in debate, as well, is difficult to restrain in view of the complexity and wide-ranging nature of House business, and the fact that apparently irrelevant remarks may relate, however indirectly, to the question. Consequently, the rules respecting relevance and repetition are difficult to define and to enforce. If applied rigidly, they can severely curtail debate; if used improperly, they have a serious effect on a Member's right to be heard.

The problem here is that it is often hard to anticipate where a line of argument might be going, and hence the Speaker must give the proponent of the argument a certain degree of latitude before challenging him with a point of order. This means that there should be a presumption that Members will behave with decent decorum, and not go beyond the boundaries of civility in dumping useless information or uncalled-for harangues on their fellow parliamentarians.

What should the Speaker do when, as sometimes happens, a participant goes beyond these bounds of good manners? How should he judge when a Member does so? If the Speaker can not effectively deal with such offenders, and is too lax, letting them get away with tactics of irrelevance, important national decisions will be made on the basis of bad arguments and incomplete information. Instead of being based on an informed view of the issues, the important arguments *pro* and *con* being given a good hearing, challenged, and intelligently evaluated, decisions may have to be made hastily or be delayed.

These dangers have been especially prevalent in recent times, where there has been a tendency to stage emotional rhetoric, packaged as dramatic "sound bites," and passionate personal posturing, this getting attention from the public and the media. Acceptance of this style of rhetoric appears to have gained ground in parliamentary and congressional debates in recent years. Aggressive and intrusive argumentation in public debate appears to be tolerated to a greater degree, rather than being rejected as unseemly conduct. In addition, more emphasis on the personal and emotional aspects of the private lives of public figures has become a preoccupation of media reporting of political news.

If the debate in the House of Commons is on a particular bill, then the time allotted for discussion of that bill will have been agreed on in advance. If a Member persists in spending a lot of time talking about something that is not relevant to this bill, the Speaker should request that the Member in question either show why he thinks it is relevant or get back to the real subject of discussion. However, such a request is a matter of judgment and decorum, depending on the cooperation of all the Members. It is not an absolute matter because of the pragmatic nature of judging whether something is relevant to a discussion. The problem, as noted, is one of trying to anticipate where a line of

argument is going. Something that did not seem relevant at the beginning of an argument may be revealed to be relevant later on, as more considerations become apparent.

## 2. THE PROBLEM OF RELEVANCE IN POLITICAL DEBATE

The following case could be called the train case, because although the debate was supposed to be confined to a particular bill, the arguer spent considerable time detailing the financial hardships of railway employees who may be affected by government cutbacks. The problem will be to evaluate whether or not his arguments were relevant. The subject of this debate was Bill C-78, the Labour Adjustment Benefit Act, a bill designed to reduce financial hardship for employees laid off from particular industries designated by the government. This bill was passed into law on May 1, 1982. A summary of the bill which appeared in the *Ottawa Letter* (Vol. 15, no. 71, May 10, 1982) described it as providing for "payment of pre-retirement benefits of 60 per cent of average weekly insurable earnings based on the last 20 weeks of employment before a layoff . . ." (p. 561). This debate on Bill C-78 was the second reading, a stage where discussion is supposed to be on the principle of the bill. At first reading, a bill is tabled or announced, but not discussed yet in open debate. At third reading, it has gone through amendments, and debate is closely confined to the contents of the bill. Discussion at the second reading is allowed to be wide-ranging, but debate on individual issues can be ruled as out of order. Thus, at the second reading of a bill, it may be difficult for the Speaker of the House to prevent a member from launching into a tirade on some issue or problem that is not really relevant to the bill under consideration.

In the midst of this debate on the Labour Adjustment Benefit Act, Mr. Thomas Siddon started into a detailed discussion of the plight of employees of VIA Rail (the Canadian National Railways Passenger Service), who may be affected by proposed government cutbacks on passenger rail services. Appealing to emotion, Mr. Siddon went over a list of small towns, saying, "Many people in those towns are heartbroken. . . ." He then went even further in appealing to pity, by citing the case of an elderly widow, incapacitated by a medical problem. He told the story of Mrs. Jane Lamont, a sixty-year old widow who, although "partly incapacitated by a medical problem," operates a little store on the Canadian National Railway in the small station in Blue River. Passengers on the train buy "candy or treats for their children, or perhaps a curio in her small store." This speech certainly looks like political rhetoric that is intended to have a mass popular appeal, and it is unclear how such matters could be relevant to the debate on Bill C-78.



At this point, the Speaker objected to Mr. Siddon's speech, calling it irrelevant, and asking him to get back on track. Following this interjection, there was a dispute on relevance, quoted below.<sup>2</sup>

(23) **Mr. Bujold:** Mr. Speaker, I apologize for interrupting the debate a second time this afternoon, but I suggest my hon. colleague's remarks have nothing whatsoever to do with the bill which is before the House. I certainly do not see why he should waste the precious time of the House criticizing the Via Rail scheme instead of dealing with this important piece of legislation. I submit, therefore, Mr. Speaker, that you should call the hon. member to order and restrict him to the point of the bill now before the House.

[*English*]

(24) **The Acting Speaker (Mr. Ethier):** I am sure all hon. members understand that it is very difficult to follow the rules of relevancy unless we have the cooperation of all members of the House. A member might speak to the bill, and I think the most the Chair can do is to invite hon. members to observe the rules of relevancy. The rules I try to apply are hon. members' own rules. As I read it, the bill before us is to provide for the payment of benefits to laid-off employees and to amend the Canada Labour Code. I invite the hon. member for Richmond-South Delta (Mr. Siddon) to indicate to the Chair how his remarks relate to the bill. That is all the Chair can do.

(25) **Mr. McGrath:** Mr. Speaker, I rise on the same point of order. I do not have the pertinent Beauséjour citation before me, but if Your Honour refers to Beauséjour, I think you will find that under our rules, at second reading of a bill a member is entitled to speak about the principle of the bill and not its details. That gives him some considerable latitude and gives the Chair considerable latitude in interpreting the rule of relevancy.

(26) **The Acting Speaker (Mr. Ethier):** The Chair did not stop the hon. member from speaking. I invited him to indicate to the Chair how his remarks relate to the bill. Even at second reading we do have to speak about the legislation before the House, so I invite the hon. member to do so.

(27) **Mr. Siddon:** Mr. Speaker, I do not intend to apologize for the extent to which I am explaining the problems which confront the people of Canada who are going to lose their careers and their livelihood as a consequence of regrettable decisions taken by the Government of Canada. I have detected a strong sense of concern and anxiety, and

---

<sup>2</sup> The segment quoted above was part of a debate that took place in the *Canadian House of Commons Debates* (November 6, 1981, pp. 12615-12619) during the second reading of Bill C-78.

perhaps even regret, on the part of hon. members opposite that I should have to rise today and use the time of my intervention dealing with a very important labour problem in this country.

There could be a connection between Bill C-78 and the issue of the prospective unemployment of these VIA Rail employees because Bill C-78 does relate to layoffs and unemployment. But Bill C-78 covers a specific type of benefit for employees laid off in designated industries. It is not clear yet that VIA Rail would be one of these designated industries. But Mr. Siddon is not arguing that it should be one of the designated industries. Rather, he is bemoaning their plight generally. And even if he were arguing that VIA Rail should be a designated industry, this would presumably not be relevant at the second reading of the bill because the decision on designation is taken at a later stage by the government.

It begins to appear, in short, that however anyone might feel about these possible layoffs in VIA Rail, it should not reasonably affect how they might vote on Bill C-78 in any substantial way. Bill C-78 should be discussed on its own merits, and the issue of these VIA Rail layoffs does not affect Bill C-78 one way or the other, as far as anyone can tell. Making this point succinctly, in speech (10), Mr. Antonio Yanakis objected that the VIA Rail issue "has absolutely nothing to do with Bill C-78." The Acting Speaker agreed, saying "This is rather clear," adding that he was waiting to see whether Mr. Siddon's speech was going to be connected to Bill C-78. Having given Mr. Siddon this much latitude, the Acting Speaker then invited him to limit his further remarks to Bill C-78.

When challenged however, Mr. Siddon replied by citing several respects in which he thought his remarks were relevant to Bill C-78. At the beginning of his speech, he proposed that the tourist industry in Jasper, Alberta, should be a designated industry under Bill C-78. VIA Rail does go through Jasper, but it is not easy to see how the proposed cutbacks in VIA Rail, the subject of Mr. Siddon's previous speeches, relates to the designation of the tourist industry.

Going back to the VIA Rail cutbacks, Mr. Siddon claimed, "There are many aspects of this bill which pertain to the regrettable decisions the Minister of Transport has taken." He then attempted to make the connection by mentioning several clauses of Bill C-78, adding "[the government] had better start considering the need to extend these provisions to the massive unemployment their politics are producing in many industries, including the railway industry." This move was an attack on the government, accusing it of causing "massive unemployment" and reverting specifically to the VIA Rail issue. Is any of this really relevant to the consideration of Bill C-78? It appears not. Mr. Siddon is simply repeating his attack on the VIA Rail layoffs by insisting, implausibly, that this issue is relevant to the discussion of Bill C-78.

Mr. Siddon's move is interesting here, because the VIA Rail layoff question is not really relevant to the debate on Bill C-78. By insisting that some connections can be made between the subject-matter of the VIA Rail layoffs and Bill C-78, he resisted the Acting Speaker's pressure to be relevant. In some respects, the two issues are relevant to each other. Both concern the hardships of layoffs in Canadian industries. But is this the kind of relevance required to sustain the relevance of Mr. Siddon's speeches on the VIA Rail layoffs to the current debate on Bill C-78? Quite clearly, it is not. This shows that topical relevance is one thing, and material relevance in a context of discussion quite another. A speech may be topically relevant to an issue—it may contain some of the same topics, for example, and have related subject-matters—but the issue raised in the speech may be materially relevant to another issue currently being considered, discussed, or debated at a particular stage.

What is absolutely remarkable about this debate is how a member can intrude into the middle of a discussion of a specific bill, and use the occasion as a platform for an irrelevant attack. He may attack the government on an issue that is important to him, but is not materially relevant to the current debate. It shows how a persistent member can engage in such a diversionary exploit with impunity, despite the best efforts of the Speaker and others to apply the rule of relevancy. This case is comparable to the classic case of irrelevance in political debate outlined in (*Prag. Theory*, 1995, 164-169). In this case, a member launched into an attack concerning a scandal about rotten canned tuna fish during a debate on a bill about family allowances. Challenged on relevance, the member argued that families and single parents struggling to raise small children were “often surviving on tuna” (165). Thus the tuna scandal was made topically relevant to the family allowance bill, but was it materially relevant? Not really, but it would be difficult for the Speaker to prove it. This tactic shows how an arguer will try to find some adventitious connection that might rebut the charge of irrelevance. This case, like the one above, shows how difficult it is to effectively maintain material relevance in a political debate.

Legal argumentation in a trial has procedural rules that define and regulate relevance much more tightly than is customary in political debating. It is instructive to examine what these rules of relevance are and how they work in Anglo-American law.

### 3. RELEVANCE IN EVIDENCE LAW

The concept of relevance is fundamental to rules of evidence in law. Rules of evidence are used to determine what kinds of arguments are admissible as evidence in a trial. As shown in chapter 1, the Federal Rules of Evidence (FRE) are based on the notion of relevance. Even a cursory glance at these rules raises a fundamental question of whether the notion of relevance in legal evidence is

based on some underlying notion of logical relevance. This question has been highly controversial. As noted in chapter 1, the history of the controversy has been outlined by Peter Tillers in a series of long footnotes in (Wigmore, 1983), one edition of Wigmore's monumental work on evidence law, *Evidence in Trials at Common Law*.<sup>3</sup> This not very well known history of the subject shows that just before and during Wigmore's time, there were controversies about the relationship between logical and legal relevance. Some denied that there is any logical notion of relevance underlying the legal notion.<sup>4</sup> The approaches to relevance expressed in these controversies led to an influential model of legal relevance put forward by Wigmore (1913; 1931; 1983). Wigmore's theory viewed logical relevance as the underlying foundation of the legal concept of relevance. He thought that there was a "Science of Proof" or logical structure of reasoning underlying the trial rules of evidence. There is much support for Wigmore's theory in the FRE, but these issues of the relationship between logical and legal relevance are still highly controversial.

As indicated previously, the two techniques in use in current informal logic and artificial intelligence, called *argument diagramming* and *argument chaining*, are the basic conceptual tools for determining relevance. These techniques can also be applied to show how the structure of logical relevance works in legal argumentation. Bentham used argument chaining in his so-called natural system of relevance.<sup>5</sup> Wigmore's chart method of picturing the mass of evidence in a trial was a precursor of the modern technique of argument diagramming. These methods are combined in this chapter to show how logical relevance can be modeled in a given case of legal argumentation. Chapter 1 has already discussed the relationship between logical relevance and the exclusionary rules of legal evidence in the FRE that bar certain kinds of arguments, like character evidence, for example, as irrelevant. The notion of probative weight is the basis of the definition of relevance given in the FRE, and it can be traced from Wigmore back to Bentham.

Some commentaries on the legal concept of relevance help to reveal more about the nature of the connection. Relevance is an important legal concept used to limit arguments that can be used in a trial. According to Roberts (1993, p. 91), the relevance of an argument in a legal case is determined basically by the "facts at issue" in a case and the manner in which the argument is probative of

---

<sup>3</sup> The full title of the work referred to as Wigmore's *Treatise* is *A Treatise on the System of Evidence in Trials at Common Law*, first edition published in Boston in 1904-1905. The later edition edited by Peter Tillers, cited in chapter 3 as 'Wigmore (1983),' contains important commentary on relevance issues.

<sup>4</sup> A summary of the controversy can be found in Wigmore (1983), in the commentary of Peter Tillers (chapter 3, section 4, 'Modern Theories of Relevancy, 1931-1981'). Significant sources are Michael and Adler (1934), James (1941) and Ball (1980).

<sup>5</sup> An excellent summary of the views of Locke and Bentham on evidence, as well as an outline of Wigmore's theory of evidence and views on relevance, is to be found in Twining (1985).

them. This remark helps to show how legal relevance is based on something called probative value (or probative weight). In the account of legal evidence given in Strong (1992), there are two components of relevant evidence: materiality and probative value. Materiality “looks to the relation between the propositions for which the evidence is offered and the issues of the case” (p. 773). Probative value is “the tendency of evidence to establish the proposition that it is offered to prove” (p. 774). Other commentaries help to clarify legal relevance by telling us that material relevance is defined by the issue in a case. According to Mueller and Kirkpatrick (1995, p. 249), legal relevance is “determined by the issues raised by the parties, the other evidence introduced, and the applicable substantive law.” What determines relevance in a legal case are the “facts to be proved,” which determine what is “at issue” in the case. Anything that cannot be used to prove or disprove “the ultimate facts properly in issue” in a case are irrelevant (Imwinkelried, 1993, p. 33). According to Roberts (1993, p. 69) the *facts at issue* are the factual allegations in an appropriate legal document made at the outset of a legal proceeding, whether civil or criminal, by the party responsible for initiating the proceeding. In a criminal case, the appropriate document is a “charge” containing factual allegations that, if proved, would “realize or fulfill the elements of the cause of action or offense” (p. 69). Another way of putting it (p. 70), is that the facts at issue in a particular case are “the principal facts to be proved by the party bearing the burden of proof on a particular issue.” Hence, what is relevant in a case is what is part of any argument that can be used to prove or disprove one or more of these principal facts at issue in the case.

Rule 401 (quoted in chapter 1) gives this definition of relevant evidence: “evidence having any tendency to make the existence of any fact that is of consequence to the determination of the action more probable or less probable than it would be without the evidence” (FRE, p. 18). The “action,” as noted in chapter 1, is the proposition that is required to be proved in the case, as explained in a helpful elucidation. According to the FRE (p. 19), “Relevancy is not an inherent characteristic of any item of evidence but exists only as a relation between an item of evidence and a matter properly provable in the case”. But now the problem arises. How does a judge determine, in any given case, whether a given item of evidence does make a matter, properly provable in the case, more probable or less probable than it would be without the evidence?

Such a decision must be made by a judge by fitting the piece of proposed evidence into the context of a case, and trying to see where the argument would lead, as it might affect the issue or “action” of the case. He must use his experience of comparable cases to estimate the probative bearing of an argument on the issue of a particular case. According to the account of relevance in Strong (1992, p. 778), the judge must ordinarily use his “own experience, his general knowledge, and his understanding of human conduct and motivation to assess the probative value of evidence in relation to the issue of a given case.”

How such a determination ordinarily works is illustrated by the following case (Strong, 1992, p. 778):

*Case 8.1:* If one asks whether an attempted escape by a prisoner charged with two serious but factually unconnected crimes is relevant to show consciousness of guilt of the first crime charged, the answer will not be found in a statistical table of the attempts at escape by those conscious of guilt as opposed to those not conscious of their guilt. The judge can only ask himself, could a reasonable juror believe that the fact that the accused tried to escape makes it more probable than it would otherwise be that the accused was conscious of guilt of the crime being tried? If the answer is yes, then the evidence is relevant.

Probative weight is estimated by the judge on a basis of trying to predict whether the item of evidence being evaluated would persuade the trier (the jury, in the case cited by Strong) to accept the “action” at issue as more probable. But how is this kind of judgment made? What is the evidential basis of an attempt to make such a prediction?

In order to determine relevance in a real case being put to trial, it would seem that a judge would have to have knowledge of many facts, as well as of matters of substantive law affecting the case. Some of the components of the required knowledge have been elucidated by Strong (1992, p. 773):

There are two components to relevant evidence: materiality and probative value. Materiality looks to the relation between the propositions for which the evidence is offered and the issues in the case. If the evidence is offered to help prove a proposition which is not a matter in issue, the evidence is immaterial. What is “in issue,” that is, within the range of the litigated controversy is determined mainly by the pleadings, read in the light of the rules of pleading and controlled by the substantive law. Thus, in a suit for worker's compensation, evidence of contributory negligence would be immaterial, whether pleaded or not, since a worker's negligence does not affect the right to compensation.

The worker's compensation example illustrates very well how material relevance works in law. By laws that exist, a worker's negligence does not affect her right to compensation. So a claim of negligence, even if it could be proved, has no probative value in a case where the issue is whether the worker should receive compensation, or how much she should receive. A claim of negligence, or any evidence of negligence in the case, is irrelevant because even if proved, it would not carry probative weight in deciding the issue of compensation.

Judgments of material relevance of an item of evidence in a given case, as indicated above, are dependent on both the facts of the case and the law that is applicable to the case. They may also be dependent on facts about related cases. Indeed, judgments of whether one case is relevant to another are vitally important in legal argumentation. The problem is the following. If the determination of legal relevance is so dependent on facts, cases, and law, how could it ever be determined by any abstract mechanism of logical reasoning? How could some underlying notion of logical relevance be useful at all, when the process of judging relevance is so heavily case-based? To judge one case as relevant to another or not surely requires the experience of a judge, and could not be carried out by any kind of automated logical method. But there have been computer studies on how to evaluate claims that an argument used in one case is relevant or not in a different case. Ashley and Alevan (1992) have been working on an automated tutor to teach first-year law students how to look through collections of cases and find arguments that would be persuasive when transferred from one of these cases to a particular, given case. For this purpose, they use what they call *dialectical examples*, collections of cases in an on-line database of cases of certain kinds. This kind of argument from analogy to past cases is very important, because our legal system is heavily based on precedents. Relevance is also a very important notion here, because a case always poses a problem, or issue to be resolved. If you can find another case where an argument was very strong in probative value for solving the problem, or for resolving the issue by supporting one side, then that argument is likely to be relevant in the case you are working on.

The basic relevance criterion used by Ashley and Alevan (1994, p. 343) to determine whether one case is “more on point” than another relative to the problem situation is a comparison of what they call the “factors” each case shares with the problem. A *factor* (p. 339), is “a collection of facts that typically tends to strengthen or weaken the strength of the plaintiff’s argument”. The example cited (p. 339) is trade secrets law, in which the plaintiff complains that a former employee has gained an unfair competitive advantage by obtaining the plaintiff’s trade secrets (confidential product development information). Each side, in a trade secrets case, will cite precedent cases that appear to support its claim. Experienced arguers, according to Ashley and Alevan (1994, p. 340) know how to identify factors in a case, to draw analogies to other cases in terms of factors, and to avoid citing cases that favor the other side. The application of dialectical examples to relevance extends the notion of legal relevance by introducing the idea of transferring arguments from case to case. Thus an argument that was relevant in one case may also turn out to be relevant when used in a different (but similar) case. To judge whether it is relevant or not in the new case, presumably one has to abstract the line of argument from the old case, and then place it into the context of the new case where the issue (and the

factual information) is different. This skill involves a comparison of two cases and a kind of transplanting of a line of argument from one case to the other.

However this process should work exactly, what it represents is the need for an extension of the notion of logical relevance to the legal kind of situation where case-to-relevance needs to be evaluated. The process appears to work on a basis of similarity between a pair of cases. Take one case that is a murder case and another case that is also a murder case and that is similar in main respects to the first case. There will be differences. For example, the plaintiff will be different, the defendant will be different, the time of the alleged murder will be different, and so forth. But certain general features of the two cases will be the same, or similar. It may be that if you take a relevant argument out of the one case and transplant it into the second case, it will continue to be a relevant argument in that case. If so (and some other requirements are met) then the second case is useful as a dialectical example for the first, for the purpose of the Ashley and Alevan tutoring system. Thus, even though legal judgments of relevance are based on a mass of information about law and comparable cases, the core process of judging relevance in a legal case does seem to be based on some underlying notion of logical relevance.

#### 4. WIGMORE ON RELEVANCE

Relevance is a central concept in the Anglo-American law of evidence, but as Twining (1985, p. 153) showed, the law of evidence is a “conceptual minefield.” There is little basic agreement on how to precisely define terms like *relevance*, *admissibility*, *probative weight* and *materiality*, even though there is universal agreement that it is important to clearly distinguish between these terms. As Twining showed, the most important formulation of these concepts was that of John H. Wigmore, whose theory of evidence is based on earlier notions formulated by Locke and Bentham. Wigmore's theory has been controversial, but it has also been carried over as the basis of the *Federal Rules of Evidence*, the set of rules that defines what is or is not evidence in U.S. Federal Courts. The FRE is subject to changes, and you can see the latest version on the *Evidence Site* on your internet search function. To get a beginning idea of what legal relevance is, or at least how it is defined in Anglo-American law, it is best to start by explaining Wigmore's theory briefly and seeing how it is expressed in the FRE.

Before doing that, a prior point needs to be discussed. The issues concern the relationship between logical relevance and legal relevance. Are these concepts the same, or is legal relevance different from logical relevance? And if it is different, is legal relevance based on logical relevance, or is it a separate notion? As previously noted, before Wigmore's time, and even during and after, there was much controversy among evidence theorists about this issue. The



controversy is summarized very well in the revised edition (volume 1A) of Wigmore's treatise, *Evidence in Trials at Common Law* (1983), edited by Peter Tillers (pp. 1004-1095). As Tillers showed, the theory of relevance proposed by Michael and Adler (1934) placed heavy stress on the concept of logical relevance. They tried to define relevance on a basis of Aristotelian logic and logical positivism, and the attempt was not highly regarded by Wigmore (Tillers, p. 1005). Their general conception of relevance is somewhat comparable to the idea of dialectical relevance in that relevance is defined by them as basically determined by the issue of a case. But they tried to use probability in the statistical sense to define probative weight (Michael and Adler, 1934, p. 1284), and this way of defining relevance gave it a positivistic flavor that Wigmore and others did not agree with (James, 1941). Even though this analysis did not find many supporters, it did pose the problem of the distinction between logical and legal relevance in a pointed way (Ball, 1980). The history of subsequent positivistic attempts to define relevance using techniques of mathematical probability is chronicled by Tillers (1983, p. 1012). Although interest in this type of analysis persists, according to Tillers (p. 1013), it has had "little direct influence on proof taking processes in courtrooms". Wigmore pursued a different kind of analysis of relevance, and his line of thinking has been much more influential.

Wigmore's theory of evidence is most fully expounded in his *Treatise (Evidence in Trials at Common Law, 1983)*, but he gives a concise outline of it in *The Principles of Judicial Proof* (1918). Wigmore held that there is what he called a "Science of Proof" that defines what is normally referred to as "logical relevance," or what might better be called, after chapters 5 and 6, dialectical relevance. Wigmore's notion of logical relevance is most easily explained in his own words, describing a typical case of a kind that occurs in a trial. In such a case, a large body of alleged facts is put forward in court by many different witnesses. This body of propositions is called the "evidence" in the case, even though it is likely to be inconsistent as a set. But such a body of evidence can be viewed as a set of propositions, each of which has a certain degree of plausibility, or what Wigmore called "probative weight." Some propositions may be highly plausible while others may be questionable, and therefore have only a small probative weight. The logical problem posed is the following: How do you collect all these propositions together into a body of evidence in a case, and then determine how they should, as a whole set, affect the probative weight of the ultimate proposition at issue (the thesis to be proved by the one side or thrown into doubt by the other side)? Wigmore's answer (*Principles*, p. 749) is conveyed by an illustrative example:

For example, assuming that the mind has accepted certain subordinate facts, A, B, C, D and E; and that A, B and C point to X, the defendant's doing of an act, while D and E point to Not-X, *i.e.* his not doing it; there

is no law (yet known) of logical thought which tells us that  $(A + B + C) + (D + E)$  *must* equal Not-X.

The issue in the case is whether X or not-X is more strongly supported by the whole body of given evidence in the case. Wigmore writes that there is no “logical law” or logical method that tells us which conclusion should be accepted—X or not-X. But we do know that in any given case, we will come to one conclusion or the other. What method can we use then to judge the relevance of each separate bit of evidence, A, B, C, D or E, in a given case? Wigmore's answer is what he called an evidential chart (*Principles*, pp. 751-756), a kind of argument diagram in which each of the single steps of inference in a given case is chained together with each other single step in the whole body of evidence. The outcome is a Wigmore evidence chart, an elaborate kind of argument diagram that shows the structure of all the steps of reasoning in a given case. The ultimate issue, or proposition to be proved, the X or not-X in Wigmore's example, will be at one end of the diagram. In fact, there will be two diagrams in any given criminal case—one representing the body of evidence in favor of the prosecution and the other representing the body of evidence in favor of the defense.

Wigmore used complicated-looking evidence charts to represent the argumentation on both sides of a case, showing how all the small steps of not very persuasive arguments make up a mass of evidence that is persuasive. An example of a Wigmore chart (Wigmore, 1913) is shown on the next page. It is not necessary or useful to go into all the details of Wigmore's elaborate notation for evidence charts here. It is enough to grasp the general idea of how a Wigmore evidence chart resembles an argument diagram in its main structure. There is a set of points representing various propositions. Each proposition represents some presumed fact, brought in as evidence in a trial, or some conclusion that can be inferred from such a presumed fact. A mass of evidence in a case can be represented by a large evidence chart that shows the structure of all the steps in the reasoning. There will be one big evidence chart representing the evidence on the prosecution side in a criminal trial, for example, and another big evidence chart representing the evidence on the defense side. Each big chart can be broken down into smaller clusters representing subissues or smaller chunks of evidence in the larger mass of evidence. The evidence chart, as Wigmore (1913, p. 47) puts it, is a method of addressing the everyday problem in courts of justice “of collating a mass of evidence, so as to determine the net effect which it should have on one's belief”. The claim appears to be quite plausible that the essential structure of a Wigmore evidence chart is that of an argument diagram of the kind used in informal logic. If this claim is correct, it may come as a surprise to many, that Wigmore is an important precursor of the modern informal logic movement. Although the method of argument diagramming is commonly said to have been invented by Monroe Beardsley in

## Evidence Chart for COMMONWEALTH v. UMBELAN

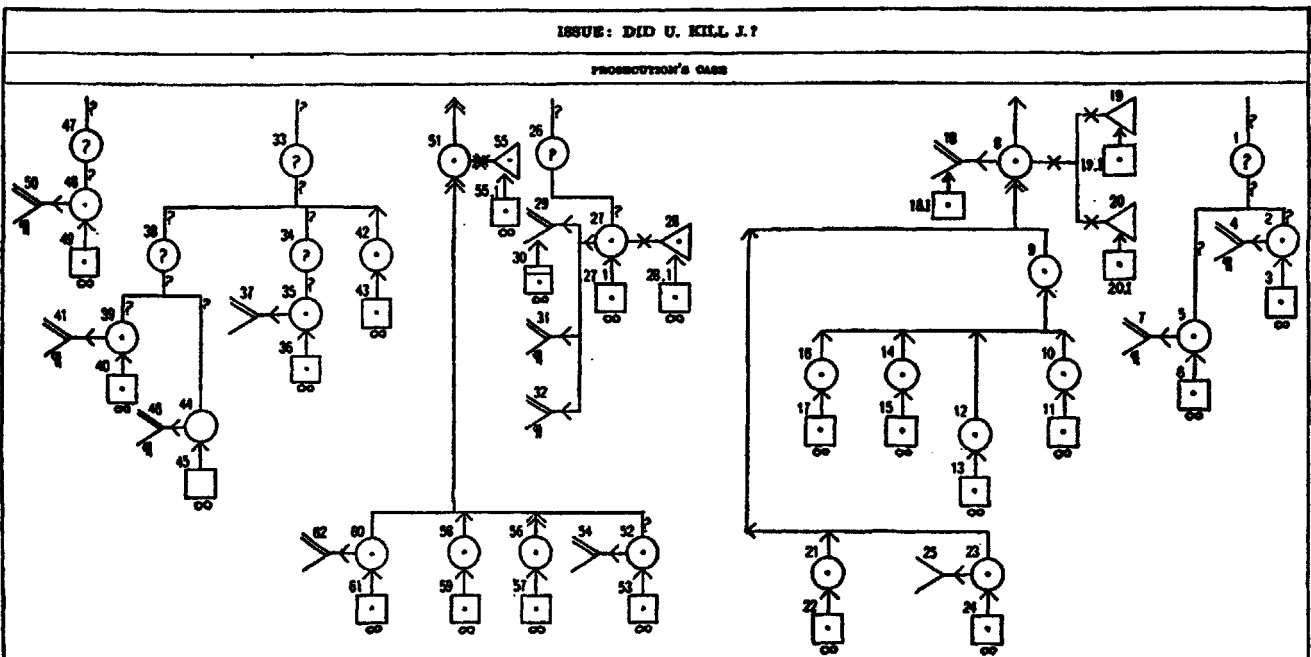

his book *Practical Logic* (1950), Wigmore’s chart method lays better claim to that distinction (Goodwin, 2000).

Well before Wigmore’s time, however, the method of argument diagramming was in use by Richard Whately, the English logician and Archbishop of Dublin. In appendix III of his textbook *Elements of Logic* (1836, pp. 420-430), entitled ‘Praxis of Logical Analysis’, he described a method of argument analysis as a method of taking “any train of argument that may be presented to us” and reducing it to a form in which logical rules can be applied to it. Basically, the method is to first of all try to figure out what the conclusion of the argument is supposed to be, and then trace the reasoning backward, to try to see what ground that assertion was made on (p. 421). Then once you have arrived at premises that represent this grounding, you can repeat the process, searching for further grounds for these premises (p. 422). The result is what Whately described as the construction of a “chain of arguments” (p. 422), a process he represented by a diagram exhibiting the chain of reasoning, in a footnote on the same page. He wrote (p. 422), “Many students probably will find it a very clear and convenient mode of exhibiting the logical analysis of a course of argument, to draw it out in the form of a Tree, or Logical Division; thus,” and then he presented the following diagram:

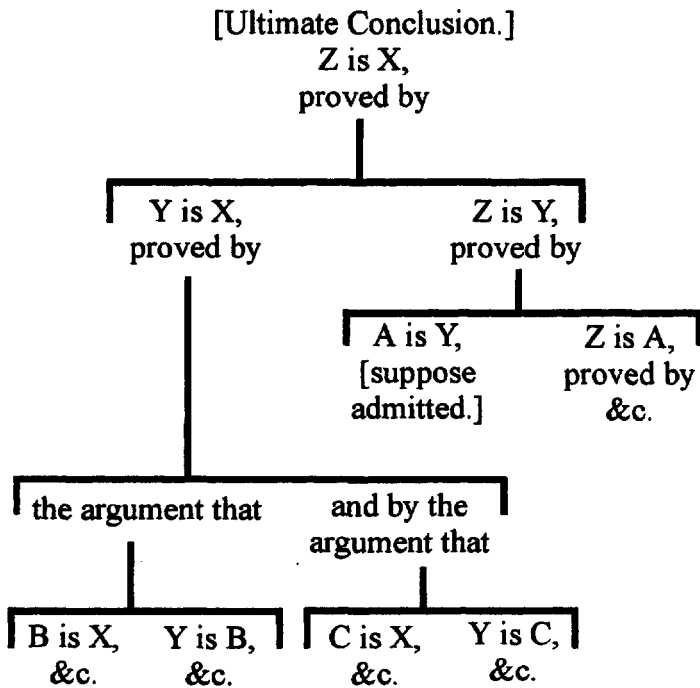

Figure 8.1: Whately Diagram

Figure 8.1 has many of the basic characteristics of the modern argument diagram. Statements are represented as the nodes, joined by lines to make up a tree or graph structure. The structure represents a chain of argumentation with an ultimate conclusion at one end. Whately even labeled the statement at the root of the tree “Ultimate Conclusion.” Each link or single step in the chain of argumentation takes the form of a conclusion backed up by premises at the next level. Thus, Whately wrote that the ultimate conclusion is “proved by” two premises below it, grouped together. Then each premise is “proved by” a separate group of premises that appears below it. It is clear from Whately’s representation of the diagram that the structure is expandable. Thus, it is shown that the method so represented could be applied to longer and more complex examples of argumentation.

Examining Whately’s diagram carefully, along with his remarks about what it represents, it is evident that Whately has given a fairly clear and comprehensive presentation of the method of argument diagramming that predates Wigmore’s chart method. Thus, a good case can be made out for acknowledging Whately as the originator of the method of argument diagramming.

## 5. ARGUMENT DIAGRAMMING IN EVIDENCE LAW

In this section, a comparison is drawn between a technique for modeling reasoning as used in two different fields: informal logic (argumentation theory) and evidence law (legal reasoning). The technique is that of argument diagramming. It may be a surprise for legal evidence theorists that there is quite a widespread use of argument diagramming within informal logic and quite a literature showing how the technique can be modeled by argumentation systems. Evidence theory, and the study of legal reasoning in general can benefit from this literature. Wigmore’s technique of using argument diagramming to evaluate legal evidence in cases never caught on. Although Wigmore did base his theory of evidence on leading writers on logic of his time, informal logic had not yet been invented. The Wigmore diagram method did not have either the theoretical backing or the practical sophistication now provided by the recent growth and advancement of argumentation theory. Each field can benefit from the other. It is time for a joining to take place, particularly in light of the recent lively and productive research in artificial intelligence that concentrates on aspects of legal argumentation. Argumentation is being used more and more in computer models of reasoning and communication like those in multi-agent systems. The most exciting advances in the study of legal argumentation are coming from artificial intelligence. Thus, the comparison of argument diagramming in the representation of legal reasoning in evidence law with the use and development of argument diagramming within informal logic is a project of some interest.

Directed graph structures comparable to argument diagrams have also been used to represent the structure of a body of legal evidence of the kind used in a trial. In order to model the reasoning used in some of this evidence in the Sacco and Vanzetti case, Schum (1994, p. 77) set up what he called a “line of reasoning” or an “argument” that linked up the testimony of a witness named Connolly with the ultimate conclusion of the case. Schum used a diagram showing the chain of reasoning from the testimony to the claim to be proved. His technique of diagramming is similar to the method of argument diagramming now widely in use in informal logic.

To illustrate how an argument diagram can be used to represent the structure of reasoning in evidence used in a trial, the following simplified case is presented of a murder trial in which certain items of evidence featured prominently in the trial. Suppose that V was stabbed to death and some bits of hair and flesh were found under her fingernails. DNA testing showed that the flesh was that of S. At the trial of S for murder, an expert witness E testified in court that the DNA test showed the flesh to be that of S. An eyewitness W also testified that she had seen a person leaving the house where the crime was committed, just after the crime had taken place. She identified that person as S. These two items of evidence were prominent in the argumentation before the jury. One of the tasks of the jury is the so-called finding of fact. Did S in fact kill V or not? The two witnesses E and W were examined before the jury in the trial.

To model the structure of reasoning in the evidence presented in the trial, the following propositions are identified and numbered. The final proposition, number 13, is the ultimate conclusion, based on the reasoning that leads up to it.

1. If flesh was found under V’s fingernails, then that flesh belonged to the killer.
2. Flesh was found under V’s fingernails.
3. Therefore, the flesh found under V’s fingernails belonged to the killer.
4. If E says that the flesh under V’s fingernails belongs to S, then the flesh belongs to S.
5. E says that the flesh under V’s fingernails belongs to S.
6. Therefore, the flesh found under V’s fingernails belongs to S.
7. If W says she saw S leaving the house just after the crime was committed, then S left the house just after the crime was committed.
8. W says she saw S leaving the house just after the crime was committed.
9. S left the house just after the time the crime was committed.
10. If S left the house just after the time the crime was committed then S was in the house when the crime was committed.
11. Therefore, S was in the house when the crime was committed.
12. If S was in the house when the crime was committed then S is the killer.
13. S is the killer.

The argument diagram for this sequence of argumentation is represented in figure 8.2:

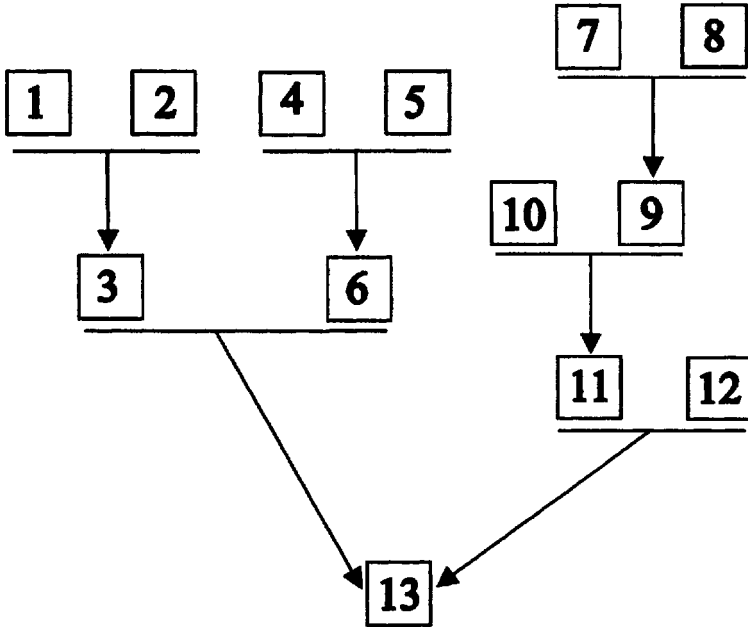

**Figure 8.2:** Evidence Diagram of the Murder Case

The structure of the argumentation in figure 8.2 can be explained as follows. The two premises 1 and 2 form a linked argument with 3 as conclusion. The two premises 4 and 5 form another linked argument for conclusion 6. Both 3 and 6, although they were conclusions, then function as premises in a linked argument having 13 as its conclusion. The chaining together of arguments is illustrated by this structure. What was a conclusion at a previous step becomes a premise at a subsequent step. On the left side of the diagram then, there is an independently standing body of evidence starting with 1, 2, 4, and 5, and leading to the ultimate conclusion 13. Now you need to look at the right side of the diagram. Here, there is a separate and independent body of evidence, starting from 7, 8, and 10 as the initial premises, which also leads to the ultimate conclusion 13. The pattern here is comparable, but slightly different. First, 7 and 8 are premises that form a linked argument leading to conclusion 9. But then 9 is used as a premise with 10, and this linked argument leads to conclusion 11. At the next step, 11 and 12 function as premises that form a linked argument leading to 13.

To sum it all up, there are two argument conglomerates, each leading to the same ultimate conclusion, 13.

This simple example can convey the basic structure of an argument diagram to the reader and show how the diagram can be used to represent the structure of the reasoning used in legal evidence. The boxes containing numbers in figure 8.2 are the “points” representing the various propositions. The arrows joining the boxes are the “steps” or inferences from premises to conclusions. Looking over figure 8.2, the reader gets an impression of how the reasoning in the evidence is structured so that it flows into the ultimate conclusion to be proved (in this case, by the prosecution side). Of course, this case makes the technique of diagramming look very simple. The basic idea is, indeed, very simple; however, there are many problems about how diagramming should be used to analyze legal evidence in real cases.

For Wigmore then, the argument diagram can be used to show the logical relevance of any single item of evidence in a case at trial to the ultimate proposition to be proved or refuted in the case. Yet, there are legal rules of relevance. What remains to be seen is the relationship between logical relevance and legal relevance. According to Wigmore, there is a Science of Proof, based on the way evidence is weighed, outlined above, which determines logical relevance in a trial. The trial is conceived as a rational process meant to seek the truth in a legal controversy. The question of whether something is to be judged relevant in a given trial at any given place and time, in a given jurisdiction, is a procedural matter. The problem is to determine what the relationship is between the Science of Proof, representing logical relevance, and the Trial Rules that define relevance procedurally in a judicial tribunal at any given time. Wigmore summarized the relationship as follows (quoted from the *Principles* in Twining, 1985, p. 156):

1. That there is a *close relation* between the Science and the Trial Rules—*analogous to the relation between the scientific principles of nutrition and digestion and the rules of diet as empirically discovered and practiced by intelligent families.*
2. That the Trial Rules are, in a broad sense, *founded upon* the Science; but that the practical conditions of trials bring into play certain limiting considerations not found in the laboratory pursuit of the Science, and therefore the Rules do not and *cannot always coincide* with the principles of the Science.
3. That for this reason the principles of the Science as a whole, cannot be expected to *replace* the Trial Rules; the Rules having their own right to exist independently.
4. But that, for the same reason, the principles of the Science may at certain points *confirm the wisdom* of the Trial Rules, and may at other points *demonstrate the unwisdom* of the Rules.



According to Wigmore's account, there is a complex but definite relationship between logical relevance and legal relevance, as defined by a given set of trial rules. The trial rules are a practical instrument, forced by the realistic limitations of any judicial tribunal. Hence, the notion of relevance in trial rules will never be the same as the notion of logical or dialectical relevance, conceived in the abstract. The exact relationship between the two notions of relevance is complex and controversial to determine. But as the previous quote makes clear, there definitely is an important (if complex) relationship.

## 6. LEGAL EXCLUSION OF RELEVANT EVIDENCE

Cases of exclusions of testimony in the courtroom on grounds of irrelevance have expanded in recent times. Courts exclude not just character evidence, like evidence of past convictions in criminal cases, but they also exclude all kinds of evidence that would normally be thought to have a bearing on the case, because it is considered prejudicial or because it may have been obtained in a way that violated someone's rights. The following example, presented by Fisher (1986, p. 8), can be used to give the reader an idea of how sweeping and significant these restrictions can be in common cases.

*Case 8.2:* . . . a widow sues in her own behalf and in behalf of the estate of her late husband for damages incurred when his truck collided with a train at a street crossing. The railroad company was determined to be at fault. Because the wheels of justice grind slowly, the case does not come to trial for 2 1/2 years. During that time her two children receive social-security payments. She receives the proceeds of her husband's life-insurance policy. His hospital and medical bills are paid by his health-insurance carrier. The widow has remarried and moved to another state with her new husband. He is and has been supporting her and her two children since she remarried.

The widow sues for the lost income of her late husband. This is based on his earnings at the time of his death, his potential for increased earnings and his estimated life span had he not been killed. The calculations are made by economists and statisticians.

The widow sues for the loss of her late husband's companionship. The children sue for the loss of parental affection, care and love.

She sues for the hospitalization and medical expenses incurred by her husband's accident.

She sues using the name she had before she remarried.

She swears to tell the truth. What she says is truthful, but it is not the whole truth. The widow cannot be questioned about her remarriage; that is irrelevant. She may not be questioned about the fact that an insurance company paid the hospital and medical costs incurred as a result of the accident. Irrelevant and prejudicial. She cannot be questioned about the fact that some of the lost income her husband would have earned is being provided by social security. Irrelevant.

Because none of these facts is considered relevant, according to the rules of evidence used in this case, a false picture of the widow's real situation is presented during the trial. Facts that would, in principle, be highly relevant to the assessment of the losses she sues for, are ruled inadmissible as evidence to be presented at the trial.

Another controversial type of evidence with respect to relevance is *hearsay*, where an out-of-court statement "is given for the purpose of proving the truth of any fact asserted in the statement" (Roberts, 1993, p. 81). The problem with hearsay as evidence is that the statement was made by someone not testifying in the trial, and so it cannot be tested by cross-examination of that person in the trial. The following case outlined by Roberts (1993, p. 82) shows that even if evidence is relevant—in this case, hearsay evidence—its admissibility may depend on how that evidence is used (case of *Walton v. The Queen*).

*Case 8.3:* In *Walton's* case the applicant (D) was convicted of the murder of his former de facto spouse. Her body had been found in a country area, severely battered about the head and with stab wounds. D appealed his conviction on the ground that the trial judge had wrongly admitted the evidence of four Crown witnesses concerning statements made to them, or in their presence, by the deceased (V).

The evidence of the first witness (W1) was to the effect that she had been present in V's house when V received a telephone call. A conversation then took place on the telephone between V and the caller during which arrangements were made for V to meet the caller at the Elizabeth Town Center on the evening of the following day. During the conversation V used words and expressions which impliedly asserted that the caller was D. Moreover, at one point V broke off the conversation by turning to her three-year-old son and telling him that 'Daddy' was on the telephone. In fact, D was not the boy's father but there was evidence that D was the only person he ever called 'Daddy.' The boy then spoke to the caller on the telephone, greeting him with the words, 'Hello Daddy.' A few words passed between them and then V resumed

her conversation with the caller. At the conclusion of the conversation V turned to W1 and told her that the caller was D and that he wanted to meet her at the Town Center on the following evening.

The evidence of the other three witnesses—W2, W3 and W4—was all to the effect that V had told them, either on the day of the telephone conversation or on the following day, that she was going to meet D on the evening of the latter day at the Town Center. The evidence of these witnesses did not refer to the fact that V had received a telephone call from D arranging the meeting on the day before it took place, whereas the evidence of W1 did refer to this fact.

The charge, in this case, was murder, and the real fact at issue was whether it was D who made the attack. W1's evidence, by itself, could not prove this fact, but it could "lay a foundation for the drawing of inferences" on this matter, if used in one of two alternative ways (Roberts, 1993, p. 83).

- i) the evidence could be offered by the Crown as proof that the person who made the telephone call was D, that in consequence of what was said during that call V left the house for the purpose of meeting D at the Town Center, and that she did in fact meet him there;
- ii) the evidence could be used to indicate V's probable state of mind when she left the house—namely, her intention at that time to go to the Town Center to meet D. This intention would then provide some explanation of what she did and could, with other evidence, justify an inference that she acted in accordance with her intention. The other evidence included a bus ticket found on V's body, and the evidence of the bus driver who sold it, tending to show that V had caught a bus to the Town Center on the evening in question.

The two ways are significantly different because the first is hearsay, whereas the second is admissible as evidence. Used in the first way, W1's testimony asserts the truth of the matters referred to in it, so it is hearsay. Used in the second way, W1's testimony is circumstantial evidence for drawing inferences about V's state of mind. Even though this second use of evidence "involves elements of hearsay" (Roberts, 1993, p. 84), it was ruled admissible on the grounds that it would, along with other evidence in the case (like the bus ticket found on her body), support the conclusion that she acted in accord with her intention to go to the Town Center that evening.

So relevance in law, in general outline, appears basically to be based on the same kind of logical relevance used in everyday conversational argumentation. It is defined by the issue in a case and is determined by how an argument

bears probatively on that issue, that is, on how it can be used to provide evidence to support or refute one side or the other of the issue. In practice, however, the way relevance is determined in a given legal case is different from the way judgments of relevance are made in everyday conversational exchanges that are outside legal discourse. In a legal tribunal, there are various rules of evidence that can be brought to bear in such a way that evidence normally considered relevant would be ruled inadmissible. Moreover, as case 8.3 shows, whether such evidence is admissible or not in a given trial depends on how it is supposedly being used by the attorney in the trial as a line of argument to prove or disprove the facts at issue in the trial.

Case 8.3 also clearly demonstrates how legal rulings on relevance in a trial can deviate from what would normally be considered logically relevant from a point of view of conversational argumentation outside a context of legal discourse. Information about the widow's present financial situation would plausibly be considered logically relevant to the issue of the losses she had incurred as a result of her husband's accidental death. So legal relevance and admissibility have to be evaluated in relation to the legal rules—especially rules of evidence—which, as a whole, are applicable to a trial, or other specific case, in a specific jurisdiction.

Cases like these clearly show that where exceptions to the general rule of relevance are set down in legal rules, the legal conception definitely departs from the logical notion of relevance that would apply in evaluating argumentation outside a legal context. Aspects of character, and other factors that probably would be taken to be relevant in everyday assessments, are expressly excluded by the rules of evidence in the law because they might tend to “prejudice” a jury, for example.

McEvoy (1994, p. 53) agreed that it is easy to show by “a contrastive analysis of a few examples” that what is irrelevant in law is relevant from a logical viewpoint of ordinary conversation. McEvoy concedes this difference even though he argues generally that relevance in law, like relevance in ordinary conversations, should be defined by an issue, set in place prior to the argumentation stage in a dialogue. In law, according to McEvoy (1994, p. 57), “the purpose of pleadings is to have the parties *join issue*,” and then to engage in materially relevant arguments together that bear on that single issue. Similarly, in ordinary conversation, relevance is defined by some (presumed) issue the conversation is supposed to be about. But because of the specific exclusions stated in legal principles of evidence, there will be specific differences between what is considered relevant legally and what would be considered relevant in an ordinary conversational argument.

The difference comes in when the law admits exceptions to its general criterion of relevance. Rule 402 shows that all relevant evidence is admissible, except as otherwise indicated by legal rules, and no irrelevant evidence is admissible. Evidence that would, from a non-legal point of view be considered

relevant, can be excluded as irrelevant on a number of grounds (Rule 403)—“prejudice,” “confusion,” and “waste of time.” Character evidence is “not admissible to prove conduct,” but is admissible on several specific grounds (Rule 404, FRE, p. 21). For example, as noted in chapter 1, the character for veracity of a witness can be questioned in cross-examination. What is shown is that the *argumentum ad hominem* can be admitted as a relevant argument in law in some (but not all) cases.

One of the most controversial types of case concerns the relevance of a victim's past sexual conduct in a rape trial. Traditionally, details of a victim's prior sexual conduct were permitted to be introduced as evidence in a rape trial. Under Rule 412 (FRE, p. 32), “reputation or opinion evidence of the past sexual behavior of an alleged victim of such rape or assault is not admissible”. There are three kinds of exceptions cited (FRE, p. 34), but before evidence can be admitted under the heading of any of them, the defendant has to present evidence in a private hearing before the judge to show why the evidence should be admitted. The first kind of exception arises “where the constitution requires that the evidence is admitted.” The second arises where “the defendant raises the issue of consent and the evidence is of sexual behavior with the defendant.” Listing all the various grounds of exclusion is not important here, however. What is important is to recognize that there exists a large class of cases where legal rulings on relevance of evidence will be quite different from judgments about whether an argument is to be considered dialectically relevant outside a court of law. There will be plenty of cases, like case 8.2, where evidence that would be considered logically relevant is not considered legally relevant.

## 7. THE NATURAL SYSTEM OF LEGAL RELEVANCE

It is worrisome, and worth noting, when the rules of relevance, as applied in legal trials, start to depart too much from the logical model of relevance. One begins to wonder if the courts are being “illogical” in excluding kinds of evidence that plainly are relevant, in the logical sense. The courts may seem to go too far in trying to protect the jury from evidence that might be “prejudicial.” Shouldn't the legal system assume that people on juries are intelligent enough, or are good enough at critical thinking to judge these matters for themselves? The danger of the jury being ignorant of evidence that might be logically relevant is surely the other side of the danger of the jury being prejudiced.

One way to react to this worry is to propose that all the exclusionary rules should simply be removed. According to this proposal, if some evidence is logically relevant, then it should also be considered *prima facie* legally relevant in a trial (subject to exclusion on a case-by-case basis). This proposal is not as radical as it might initially seem to be. There exist legal systems that do not have the kinds of exclusionary rules characteristic of the Anglo-American system.

Exclusionary rules of the kind exemplified in the FRE exhibit a “prophylactic orientation” that is a salient trait of Anglo-American law, as contrasted with continental law (Damaska, 1997, p. 12). Exclusionary rules, like the rule prohibiting the use of illegally obtained evidence, can also be found in continental legal systems, but they are markedly more prominent in the Anglo-American common law system. According to Damaska (197, p. 15), there is no real analog in continental law to the routine exclusion of evidence in Anglo-American law on the grounds that its probative weight is too slight or that its connection with the material facts of a case is too remote. Even more “peculiar” in the Anglo-American system is the exclusion of evidence on the ground that it might tend to “prejudice” the trier (p. 15). It is for these reasons that Damaska characterizes the Anglo-American law of evidence as “adrift” in the title of his book.

The idea in Anglo-American law of barring probative evidence in court on grounds other than concern for fact-finding accuracy appears to be relatively recent, judging by the brief history of the subject given in Damaska (1997, p. 14). It appears that preference for such exclusionary rules became prevalent in the United States after World War II. The recent advent of such rules, along with their relative absence in the continental system of law, raises the practical possibility of having a system without such rules. In a system without them, there would be no real difference (or not such a marked difference) between logical relevance and legal relevance.

Indeed, it is possible to find an influential advocate for such an approach to legal relevance. Jeremy Bentham (1748-1832) proposed what he called a natural system of law, which was characterized by precisely this approach. Bentham was, in fact, a leading exponent of applying the concept of logical relevance to legal relevance. Bentham defined logical relevance in terms of what he described as a chaining process connecting a series of logical inferences together. This important idea of the chaining of a sequence of inferences to make up the line of reasoning in a body of evidence can be found clearly expressed by Bentham (1962, vol. 7, p. 2), who described the evidence in a legal case as a “chain of facts”. According to Bentham (1962, vol. 7, p. 65), such an evidentiary chain of propositions can take the following form: *A* is evidence for *B*, *B* is evidence for *C*, and *C* is evidence for *D*. In a case of this sort, according to Bentham, there is a chain of inferences starting from an initial piece of evidence *A*, and ending in an ultimate conclusion *D*. Bentham formulated the following principle for evaluating the strength of evidence (probative weight) provided by such a chain of reasoning (1962, vol. 7, p. 65): as the chain gets longer, the probative weight thrown on the ultimate conclusion by the initial fact (proposition) becomes weaker.

Thus, Bentham’s theory of relevant evidence is not only the basis of Wigmore’s Science of Proof. It can also be seen as the forerunner of the notion of the chaining of inferences that is now so influential in computational

reasoning in artificial intelligence. Chaining is also connected to the notion of plausibility in artificial intelligence (Josephson and Josephson, 1994). To say that a proposition is plausible, in the sense used by Josephson and Josephson, appears to be very similar to what Bentham meant when he wrote that a proposition has probative weight. Bentham's theory presumes that each proposition, or presumed fact in an evidentiary chain, has an initial probative weight. Then other propositions drawn by a chain of reasoning from these initial assumptions can be assigned a derived probative weight, depending on the nature of the chain of reasoning (for example, how long it is).

To calculate the degree of persuasion that a trier should accept in a given case, Bentham proposed what he called the Natural System. The Natural System dictates that if a supposed fact, argument, or piece of testimony, is logically relevant, in the sense indicated earlier (articulated by the chain of reasoning), then it should also be considered legally relevant, in what Bentham called the Technical System, meaning the set of rules of evidence used in trials. Twining's dialogue summary (1985, pp. 27-28) sums up Bentham's view of the matter in outline:

- Q. What are the ends of procedure?
- A. The direct end is rectitude of decision, that is the correct application of substantive law to true facts. The subordinate end is avoidance of vexation, expense or delay. Conflicts between the direct and subordinate ends are to be resolved by reference to the principle of utility.
- Q. What system of procedure is best calculated to further ends of procedure?
- A. The Natural System, that is a system characterized by the absence of the artificial rules and technical devices of the Technical System of Procedure.
- Q. When should evidence be excluded from consideration by the trier of fact?
- A. Hear everyone, admit everything unless the evidence is (a) irrelevant or (b) superfluous or (c) its production would involve preponderant vexation, expense or delay.
- Q. By what means can the legislator provide for the completeness and the accuracy of testimony?
- A. By prescribing sanctions for 'forthcomingness' of witnesses and of evidence and against mendacity; by providing admonitory instructions addressed to the understanding of the judge, concerning the value and weight of different kinds of evidence. To eschew all artificial binding rules addressed to the will rather than the understanding.

This summary of Bentham's Natural System also shows the kind of view he might have taken on modern exclusionary rules of evidence of the kind found in the FRE. It would definitely appear that he would have strongly argued against the exclusions. At any rate, a kind of Benthamite support could be given for what might be called the *naturalistic thesis*, the thesis that legal relevance, as expressed in the rules of evidence for trials, ought to simply be equivalent to logical relevance. In other words, according to the naturalistic thesis, if evidence is logically relevant in a given case at trial, then it ought to be admissible in the trial, that is, it ought to be considered legally relevant as well. The naturalistic thesis has radical implications that cut to the very heart of the rules of evidence in Anglo-American law.

Bentham agreed that evidence should be excluded if it is irrelevant or superfluous, or if it would mean undue delay or expense. Other than this, he thought that the natural system is characterized by an absence of the technical devices of the kind found in exclusionary rules of evidence used in trials. His justification for this position is to be found in what he calls the ends of procedure. What he presumably meant was that the end of a trial is to arrive at the right decision by correctly applying the law to the true facts of a case. There are many means to this end. One he mentioned is to make witness testimony more reliable by doing things like providing penalties for perjury. Generally, he thought that artificial rules that are addressed to the will rather than the understanding should be avoided. It would appear, then, that he would have thought that rules of evidence that exclude *ad hominem* arguments because they might tend to prejudice a jury are not conducive to arriving at a right decision in a trial. Bentham's position is not the one accepted by modern Anglo-American evidence law, in the FRE for example. This system has gone further and further away from Bentham's natural system. His view represents one extreme, or polar position, and current rules of evidence appear to have moved closer and closer to the other polar position.

The moderate position is Wigmore's view that there needs to be a delicate and complex balance between the trial rules and what he called the Science of Proof, representing logical relevance. The trial rules can change, and thus there is a need for a continual re-adjustment between logical relevance and legal relevance as defined by the rules of evidence at a given time and place. Wigmore's view was partly based on Bentham's theory of relevance as probative weight in argument chaining, but it is a more subtle view of legal relevance and probably one that better accommodates logical relevance to the need for trial rules. What needs to be said at this point is that when people construct artificial systems of rules for dispute resolution, like the rules of evidence law and the rules for forensic debates of various kinds, they (presumably) utilize the logical notion of relevance. However, they then go beyond this logical core notion and build in artificial restrictions of various kinds, for various purposes, and they appoint a judge or a Speaker to enforce



these rules in court or in political debates. It is very interesting to study these artificial rules of procedure, as we have seen, and try to judge just how they relate to the basic dialectical notion of relevance in the different types of dialogue, but we have to realize that they are specific to particular human institutions and tribunals of various kinds. Although they use the term *relevance* to describe their procedural rules, they may depart considerably from the logical notion of relevance, for institutional and practical reasons. If they deviate too far from dialectical relevance, as determined by the basic type of dialogue involved, they will be seen by the public as running contrary to the requirements of everyday rational thinking. That is why Bentham's extreme position is very interesting and useful in any attempt to come to understand legal relevance. Although it is not a position many would be prepared to accept as realistic, it provides a point of departure for any discussion of relevance in legal argumentation.

## 8. PROBATIVE WEIGHT IN ARGUMENT DIAGRAMMING

How argument diagramming applies to a case is relatively simple. As Wigmore's use of the technique illustrates, the diagram provides a map showing how all the connected premises and conclusions are related to each other inferentially in a body of evidence. Such a map of evidence can be quite useful. It shows the line of reasoning in a body of evidence. It reveals the missing premises that need to be assumed. It gives a clear basis for judging what is relevant, in relation to an ultimate conclusion. It sums up the mass of evidence and gives a good basis for evaluating its probative worth in a case. All these uses of the evidence diagram show its potential worth as a technique to help in evaluating evidence. Why then has diagramming never proved popular in evidence law? One reason is that in Wigmore's time, we simply did not have the resources from argumentation theory and logic to refine the technique. Another is that there are a number of technical questions concerning the method of argument diagramming that have not been resolved, and that are only now being worked on. It is too soon to say how these questions will be resolved, but there are two schools of thought working on them.

A main question is how a body of evidence should be evaluated, using the method of argument diagramming as a basis. There are two leading schools of thought on this. According to the Bayesians, numbers should be assigned to each of the premises in the diagram representing the probability value of each proposition. Then, the conclusions should be revised upward or downward in probability value, as calculated by the axioms of the probability calculus (Schum, 1994). According to the argumentation approach, assigning numbers to each proposition, as recommended by the Bayesians, is not particularly helpful in most cases of legal evidence. One reason is that margins of error are so high

that assigning exact numbers is actually misleading in many cases, suggesting a greater exactness of outcome than is possible. Instead, according to the argumentation method of evaluation, a non-numerical method should generally be used.

According to the argumentation method of evaluating a body of evidence, you first of all consider the whole connected body of evidence represented by an argument diagram summary as a database or so-called knowledge base. Then you perform some operations on it. You draw some further conclusions by chaining forward or backward, using logical reasoning. You try to eliminate the contradictions to make the database consistent. In a given legal case, there will be a basic contradiction, however. On the ultimate issue, or any main subissue, there will be several arguments for and several against the claim at issue. Essentially what you must do is to list the arguments on both sides. You need to consider how many arguments there are; you need to consider roughly how powerful each argument is (with or without attaching numbers); and you need to have an idea of how the whole body of evidence is connected. This is, of course, shown by the argument diagram. Finally, you need to have some ideas of what are the weakest links in each chain of argumentation. These are the specific premises or arguments that are open to skeptical doubts. Taking all these factors into account, you need to make a holistic judgment about which side has the strongest case, the pro or the contra. Sometimes it can be useful to assign numbers that represent so-called confidence values. But in many cases, however, they are not all that useful, and can be more of a hindrance or distraction than a help. What is important is the arguments, how they fit together, and what appropriate critical questions can be asked about the most important ones in the body of evidence on one side or the other. This whole style of analysis and evaluation of evidence could be called the *argumentation approach*, as opposed to the *Bayesian approach*.

What is vital, according to the argumentation approach, is to look at each argument in a chain of reasoning used in the evidence, and identify the form of the argument, or so-called argumentation scheme. Then you need to ask critical questions matching that argumentation scheme. For example, suppose the evidence is expert testimony, and the form of the argument is that of appeal to expert opinion. Matching the argument from appeal to expert opinion, there is a set of appropriate critical questions. Each of these needs to be considered in searching for the weakest part of the appeal to expert opinion, the aspect of the argument most open to critical doubt. Other factors are how many arguments there are on one side and how many on the other.

Of course, some arguments have more probative weight than others. Some are relatively strong while others are relatively weak. Is it useful to assign probability values to each proposition in an argument? Sometimes it is, and statistics can be a valuable tool in legal cases where statistical matters are relevant. The argumentation approach would prefer to use what are called

*plausibility values*, which are evaluated in a different way from probability values. The most common rule of plausible reasoning is the least plausible premise rule, sometimes called *Theophrastus' Rule*: The plausibility of a conclusion in an argumentation scheme, or chain of arguments in an argument diagram, should be at least as plausible as the least plausible premise. The least plausible premise rule does not always apply, however. It is vitally important to distinguish between linked and convergent arguments. In a linked argument both (or all) premises are required in order to support the conclusion. In a convergent argument, each premise is an independent line of support for the conclusion. In a convergent argument, there are several different arguments, each of which, standing alone, offers significant probative weight as a reason for accepting the conclusion. In a linked argument, the premises are connected, typically as parts of an argumentation scheme. Hence they provide much more probative weight to support the conclusion by functioning together.

There are many technical problems to be resolved before it can be shown whether the Bayesian approach or the argumentation approach is better as applied to which kind of problem encountered in the evaluation of legal evidence. As an example of a central issue, the applicability of the negation rule could be cited. In the probability calculus, the probability of *not-A* (the negation of the proposition *A*) is calculated by the formula of one minus the probability of *A*. But in the kinds of cases typically found in legal argumentation involving evidence, both a proposition and its opposite can be highly plausible. For example, suppose a small and weak man accuses a large and strong man of assault. The small man argues that it is implausible that he, the weaker man, would attack a visibly stronger man who could obviously defeat him. In court, the visibly larger and stronger man asks whether it is plausible that he would attack such a small man in front of witnesses when he knew full well that he could be accused of assault. Here, we have an argument with probative weight on one side, but also an argument with probative weight on the opposed side. The proposition that the large man committed assault is plausible in light of the facts, but its negation is also plausible in light of the same facts. The argumentation in this typical kind of case in the law violates the negation axiom of the probability calculus. What does that show? What it seems to show is that typically in legal cases of the kind fought out in court, there exists a fundamental contradiction or conflict of opinions. One proposition will have probative weight according to the body of evidence on one side, whereas the opposite proposition will have probative weight according to the body of evidence on the other side.

What this kind of outcome shows, according to the argumentation approach, is that probative weight should always be judged relative to a given body of evidence. A proposition can be plausible, in relation to a body of evidence in a given case, whereas the negation of that same proposition can also be plausible in relation to another body of evidence. Probative weight is a

contextual and pragmatic notion that cannot be judged semantically, in abstraction from the context of argumentation used in a given case. A plausible inference results in a conclusion that seems to be true on the basis of premises that seem to be true, in an argument that throws some probative weight from the premises onto the conclusion in virtue of its structure. Structure is represented by the argument diagram, which shows a connected chain of reasoning in which each subargument in the chain has a particular argumentation scheme. The assessment of probative weight is carried out by looking for the weakest links in the chain, using Theophrastus's Rule. This method of evaluation is different from the Bayesian approach, which uses the axioms of the probability calculus as its basic rules for argument evaluation.

## 9. THE TRIAL AS A FRAMEWORK OF RELEVANCE

One objection to Wigmore's theory is that it makes legal relevance too similar to the ordinary kind of dialectical relevance found in ordinary conversational disputation. According to this objection, legal relevance, as defined in the law of evidence, is a special legal notion and does not depend on conventions of everyday non-legal argumentation. On this view, Wigmore was simply wrong to think that there is a Science of Proof, or general logic that applies to evidence outside legal discourse as well as within it. The best reply to this objection has two parts. The first is the point that in Anglo-American law in particular, the trier is often a jury made up of persons who have no special training in law. They will decide the issue based on the kind of logic that is used to judge argumentation in everyday conversational disputation. Thus the argumentation used to persuade these people in court had better be of this everyday conversational type, or not depart too far from it.

The historical importance of the ancient theory of *stasis* for understanding relevance and irrelevance was brought out in chapter 2. That chapter also tracked back into the argumentation history from Wigmore to Bentham, and from Bentham back to ancient theorists of rhetoric. The special lesson for legal argumentation is that in the paradigm case, the institution of the trial is vital to grasping how an argument should be judged to be relevant or irrelevant. The purpose of the trial is to provide a method to resolve an issue. This issue is the central factor that determines whether an argument is considered relevant or not. There is a well-identified proposition to be proved or cast into doubt, and any chain of argumentation used in the trial will be logically relevant only if it has this proposition as its ultimate end point. The argument will then be legally relevant if it is logically relevant and also fits the trial rules that define legal relevance, like the FRE. Putting all these elements together in a historical perspective has given us a pretty good idea of what legal relevance is. But of course, the argumentation in a trial is not the only kind of legal

argumentation that can be encountered. There are pretrial arguments, for example, and there are many other kinds of legal arguments that are not directly related to trials. The trial is a method for resolving disputes in hard cases. Many cases never go to trial even though they may be subject to argumentation.

The fundamental point is that even the trial is only one stage in a sequence of stages through which legal argumentation is chained forward. An argument that is relevant at one stage of the sequence may not be relevant at a later stage. Also, as the line of argument moves forward in a trial, an argument that was relevant at an earlier stage may not be relevant at a later stage. Figure 8.3, reproduced from Yarmey (1979, p. 24) shows the different stages in a criminal prosecution leading to a trial. At the earliest stage, the evidence is collected and assessed by the police. They collect forensic evidence, and interview witnesses and the suspect. If this evidence is judged sufficient to warrant a charge, the case may go to court. At this stage, the argumentation has the form of an information-seeking dialogue. The main task is the collection of evidence. Something is relevant within that framework if it is a kind of evidence that has probative weight for potential use in the trial which may occur at the next stage.

At the next stage, the evidence is presented in court by witnesses. A witness takes an oath to tell the truth, and as Yarmey (1979, p. 26) stated, the oath “exerts pressure” on the witness to tell the truth. However, the witness may be lying. Thus, the practice of examining what the witness has testified to is used in court to determine whether the account given by the witness is plausible and is in agreement with the other known facts in the case. Examination dialogue—called *peirastic dialogue* in the ancient world—is a special type of dialogue in its own right, used to test out and probe what was said by a person who is supposed to be in a special position to know about something (Walton, 1998, p. 146). It is during the examination stage that the rules of evidence come into play in determining whether evidence is relevant or not. Once all the evidence has supposedly been examined in court, the trial moves to the next stage of so-called jury deliberations.

In this stage, the trier weighs the evidence on both sides and draws a conclusion on whether the prosecution has fulfilled the burden of proof or whether the defense has raised reasonable doubt. Clearly, the trial is a centrally important framework of dispute resolution in law, and it is to the trial that the rules of evidence apply. Therefore, in developing any theory of relevance in legal argumentation, it is necessary to begin with the consideration of the trial as the first focus of evaluation of relevance and irrelevance.

According to the Wigmoreite approach, whether evidence should be judged relevant or not in a trial depends on two components. The first is whether the evidence is logically relevant to the issue that is supposed to be decided by the argumentation in the trial. The second is whether it is excluded by some particular rule of evidence in the rules used for trials in a given jurisdiction at a

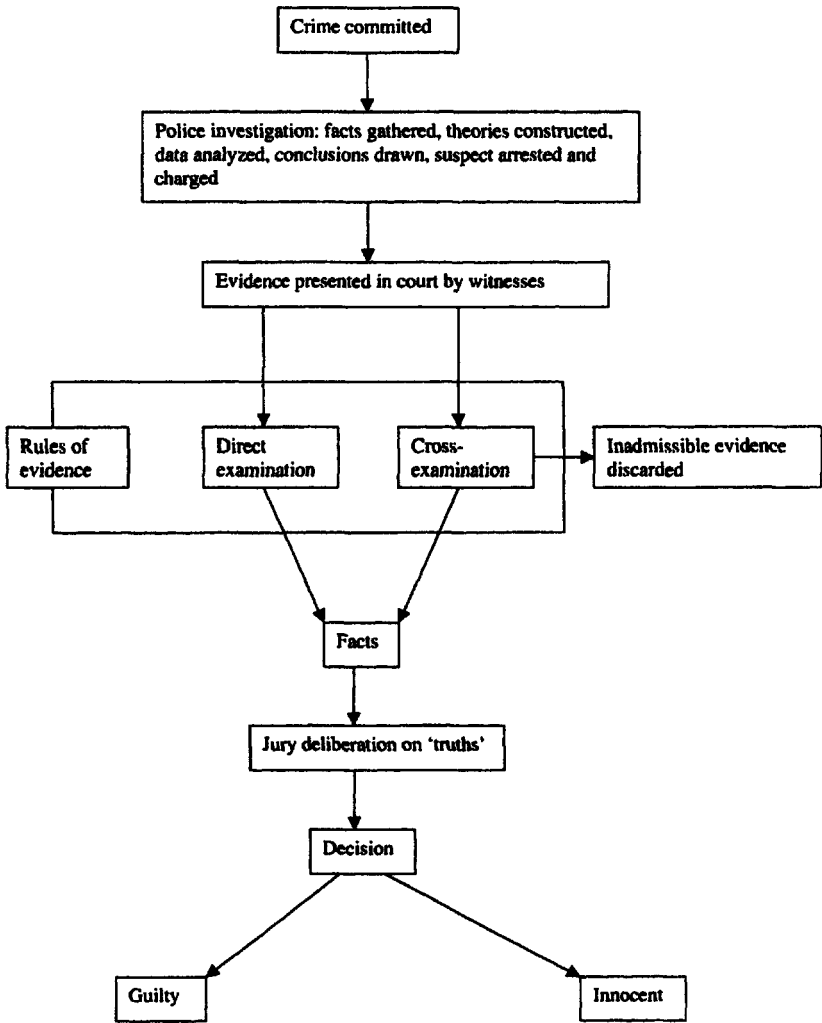

Figure 8.3: Stages in a Criminal Prosecution (Yarmey, 1979)

given time even if it is logically relevant. The second component of legal relevance is the institutional setting of the argumentation, especially the trial rules. According to this theory, there must be a balance in the relationships between these two components in making judgments of relevance in a trial. The second component represents a practical factor. Trials are expensive, and it can be a problem if all kinds of irrelevant arguments are brought in. A jury can be confused and exhausted by listening to a parade of colorful arguments that are either irrelevant or have only slight or dubious probative weight in a case. The problem is parallel to that of the filibuster in political debate. Therefore, in both types of argumentation framework, the trial and the parliamentary or legislative debate, rules of procedure are necessary in order to keep the argumentation on track. Such rules can be very helpful; they can also be manipulated, so that the second component actually interferes with or runs counter to the function of the first, as Bentham noted.

The problem of the relationship between legal relevance, as determined by a set of judicial rules, and logical relevance, as determined by normative standards, is subtle and difficult. The framers of the legal rules have to work within the practical constraints of what is possible, and realistically practical, within a given justice system. A justice system is an institution, and to function and meet its goals, rules of procedure must be set in place to govern the conduct of trials. On the other hand, the fair trial as an institution is based on the assumption that the most rationally compelling arguments on both sides should be brought forward and considered by the trier (the judge or jury). This assumption could be called the basic dialectical assumption behind the concept of the fair trial. The problem is that if too many arguments in a given trial are excluded as irrelevant, and therefore not considered at all by the trier, the failure of the basic dialectical assumption to be met throws the fairness of the trial into doubt. If a jury is not hearing all the relevant evidence, if much of it is being held back from them by rules of exclusion, can they really reach a decision based on rational argumentation, weighing all the relevant evidence on both sides? Possibly not. Where such doubts begin to creep in about the argumentation in a legal case—especially one widely viewed by the public—a skepticism about the justice system will grow. The feeling will be that trials are based on legal technicalities, and their outcomes may even be seen as illogical.

In case 8.2, for example, where the widow sued for damages and many facts concerning her financial situation were ruled irrelevant to the calculation of her losses, are the latter facts dialectically relevant? It depends on what is meant by *loss*. Should the things she gained after, or as an indirect result of her husband's death, count in calculating her *losses*? If she lost money through the death of her first husband, but then remarried and gained more income, does the new income count in calculating what she lost? It depends how *loss* is defined relative to legal precedents in this type of case. If *loss* is interpreted one way, then the facts about the new income are dialectically irrelevant. If *loss* is

interpreted the other way, then the facts about the new income are dialectically relevant. The problem is not so much one of dialectical relevance or irrelevance as one of deciding what should count as a loss in this type of case. Even so, the failure of match between logical and legal relevance in such a case is worrisome. Bentham's natural theory would suggest that the jury could reach a wrong decision because of what is not told to them, because of being deemed irrelevant.

The problem with hearsay (case 8.3) is that it is a kind of evidence that cannot be examined properly in court because the person who made the statement cannot be questioned as a witness by the participants in the trial. This is not so much a problem of irrelevance as a problem about hearsay as a kind of evidence and how it can be questioned as testimony. The issue of relevance is involved, however, because the problem is that hearsay evidence could have a prejudicial effect on a jury even though, by standards of legal evidence, it is not regarded as evidence that should carry much probative weight. The reason, as previously indicated, is that it cannot be tested (by examination of the witness) in the trial. So we see that in many of these cases, the problem is not exclusively one of relevance, but one that relates to other matters as well.

What should be said about the apparent difference in some cases between logical relevance and legal relevance? From one point of view, it is not remarkable because law, in any given jurisdiction, is determined by all kinds of factors that are not narrowly logical in nature. What is legally judged to be proper procedure in a court is determined by all kinds of values that go beyond logical models of argumentation in dialogue structures. Seeing the argumentation in a trial as natural in Bentham's sense is helpful up to a point, but the logical structure of the argumentation is not going to account for all aspects of legal rules of procedure in a trial. Whatever one should say about these questions, it has to be recognized that, because of these grounds of exclusion, the actual determination of relevance in the courts will deviate quite significantly from the basic concept of logical relevance. Such deviations should be expected, and can, in many cases, be explained. The important thing about the Wigmore approach to relevance is that it shows how a basic concept of logical relevance underlies the judgments of relevance made in trials, using legal rules of evidence. By clarifying the complex nature of this distinction, the controversies about logical and legal relevance, chronicled by Tillers in his commentary on Wigmore's *Treatise*, can be resolved. At least an account can be put forward to explain how judgments of legal relevance should attempt a balance between considerations. Logical relevance is on the one side; on the other are practical factors special to legal evidence and the institution of the fair trial as a way of deciding a disputed case.



## 10. THE CRITICAL STANDPOINT

It has been shown in this chapter that the critical analysis and evaluation of irrelevance in political argumentation is possible and extremely useful. Politicians use irrelevant arguments for deceptive and obstructive purposes to try to win a debate unfairly. They use irrelevance as a deceptive tactic, and it works very well. The capability of a speaker or moderator of a debate to deal effectively with such tactics is limited. As we have seen, rules of relevance are hard to enforce. What is needed is a more critical attitude and a better awareness of fallacies of irrelevance, not only by politicians and the media, but by citizens generally. We have seen that the rules of relevance in political argumentation are quite permissive. Depending on constraints of time and the stage a debate has reached, quite a lot of grandstanding and irrelevant argumentation can be tolerated without making a debate ineffective, even if its quality is lowered. This situation can be contrasted with that of legal argumentation of the kind found in a trial. There are carefully devised legal rules of relevance that exclude specific kinds of arguments. As shown in chapter 1, for example, there are specific rules of evidence sharply limiting the kinds of character attack arguments that can be used. *Ad hominem* arguments are not totally excluded as irrelevant by legal evidentiary rules although there is a strong presumption toward judging them as irrelevant, and they are only admissible in certain well-defined cases. In this respect, an interesting contrast can be drawn between irrelevance in political argumentation and irrelevance in legal argumentation.

In democratic parliaments and congresses all over the world, there is an increasing perception that too little time is spent on business, and too much time is spent on personal attack, “soap opera,” and combative, adversarial tactics of debating. The latter are of very little use in getting to the heart of the serious issues that should be discussed. These cases of low quality debate are, of course, not just due to failures to uphold rules of relevance. They have many causes. The situation is a triangle composed of the politicians, the media, and voting citizens generally. No single party or factor is to blame. For purposes of evaluating dialectical relevance, it is not appropriate to attempt to lay blame on any party.

However, it is alarming that parliamentary and congressional debates are too often dragged out at interminable length where the quality of debate is very low, and very little of serious interest appears to be discussed. This devaluation of the quality of debate brings the institutions of democratic politics into disrepute. The comment of Franks (1985, p. 6) on the Canadian Parliament is revealing:

The time taken by even trivial legislation has increased in recent years. Little of this increase has had to do with the desire of the House to improve legislation; a great deal of it has had to do with the desire of the

opposition to delay and embarrass the government. To the extent that this is so, the time spent in debate of government business—the most time-consuming business before Parliament—serves little purpose. It probably does not even help the opposition to win votes. Rather it brings Parliament and politicians into disrepute.

Once delay and obstruction becomes a tolerated debating tool to force the other parties to make compromises, the quality of debate suffers. Although it is true that parliamentary debate should have an adversarial aspect, too much pointless and illogical debating can be a pathological sign. It tells everyone that acceptance or rejection of legislative bills is not so much based on prudent deliberation on what is best for the country, but about quarreling and negotiation.

A rule of relevancy is one way of putting restrictions on debate in order to prevent delaying tactics. The most dramatic tactic of irrelevance is the filibuster, the technique of filling time by speaking on any subject whatever in such a prolonged speech that no time is left to debate a bill. According to Bradshaw and Pring (1972, pp. 143-144), the filibuster, made famous by the American Senate, found an early exponent in Barent Gardenier, a representative from New York who once spoke continuously for twenty-four hours to block a bill in the U.S. House of Representatives. This filibuster provoked another Member to challenge Gardenier to a duel. The latter, after being severely wounded, was said to have “returned to the House with his verbosity undiminished” (p. 144). So red herring tactics of irrelevance have been known and used for a long time. The filibuster is the worst kind of transgression of irrelevance, for even if what is said in the speech happens to be relevant in subject-matter to the bill under discussion, it does not matter.

People who use such obstructive tactics in political debates often feel they are justified in doing so on moral grounds. One could pose the problem by extending case 1.1, the case of the library committee meeting, to represent a kind of case that has become familiar to all of us in recent times. Suppose that Harry felt strongly that the issue of student fees was a question of life or death for students like him, struggling to stay in university despite rising costs. Suppose he therefore felt that disrupting the library committee meeting by angrily insisting on talking about the tuition fee issue was morally justified. Perhaps Harry even felt the issue was so important that he alerted the news media in advance that he was going to disrupt the library committee meeting by staging a colorful demonstration, where signs would display slogans demanding reductions in tuition fees, and students would dress up in colorful costumes. True, this insistence on talking about the tuition fee issue would not be on the agenda of the library committee meeting. What Harry said would be of no use in the deliberations on that agenda set for that meeting, and would be dialectically irrelevant, from that point of view. But from the point of view of his own

feelings about what was morally imperative and urgent for him and his fellow students, talking about the tuition fee issue is ethically relevant and is even more important to them. Thus, in a way, it is relevant for them. They see their disruption of the committee meeting as morally justified by a higher purpose and as relevant in relation to that purpose.

In cases like these, we can easily appreciate that there is a natural and widely accepted tendency to evaluate relevance in relation to the arguer's intentions and from a moral point of view. It is precisely with this kind of case in view, however, that we need to reflect critically on what we are doing when we evaluate an argument or move as being relevant or irrelevant. Are we evaluating the arguer morally as a person who has good or bad intentions, as we would do in ethics, or perhaps as a jury would do in a criminal trial? Or are we only evaluating his or her argument as dialectically relevant or irrelevant in the logical or critical sense that it makes a contribution at the right place in the sequence of reasoned argumentation in a type of dialogue? For the purpose of the critical evaluation of argumentation—see Hamblin (1970), van Eemeren and Grootendorst (1992) and Walton (*Prag. Theory*, 1995)—the objective should be restricted to the latter goal, and should not include the former (ethical) goal.

A legal argument used in a trial, a political argument used in a senate debate, or an argument used to raise an issue in a committee meeting, all occur in a specialized framework of a particular type of discussion. But each type of discussion is also a subtype of some more general type of discussion. The committee meeting could be classified as a type of deliberation, where the participants meet to discuss what to do, or how to proceed in a particular situation that demands some action or decision, based on a consensus or vote. A legal trial is a persuasion type of dialogue where each side has a burden of proof, or a viewpoint to advocate, with regard to the charge that has been brought forward (Feteris, 1999; Walton, 2002). The goal of each side is to persuade the jury that its contention is proved, on balance, according to the standards of proof set for this type of trial. In broad, general terms then, each of these cases fits into a type of discussion event that has a purpose in relation to an issue or problem that is supposed to be resolved by the argumentation in the discussion. The argumentation is being used to resolve a particular issue, according to the specific conventions and procedural rules that apply to this kind of event.

Any such evaluation, of course, depends on the type of dialogue the argument in question is supposed to be part of. If it is assumed that political debate is purely eristic, partisan, and adversarial, then of course, failure to keep your arguments relevant to the issue of the bill to be voted on is no fault or fallacy. However, surely it is a requirement of a genuinely democratic system that argumentation used in a debate on a bill in a parliament or congress should, at least to some extent, consist of rational deliberation on whether the proposed legislation represents a sensible course of action, as opposed to the practical

alternatives. Surely once this assumption of rational deliberation is completely set aside, it would be harder to justify the value of a democratic system of government. Political and legislative debates would be based purely on negotiation or on quarreling over interests, and not on the kind of argumentation that uses practical reasoning as a guide to prudent action. When political debates are perceived in this nondeliberative way, everyone will devalue the institutions of which these debates are a part, assuming that, as informed critical reasoners and observers of political developments, they become aware of what is taking place. So there are significant negative side effects of accepting this kind of devaluation of the way people give credibility and assent to the legislative process.

*This page intentionally left blank*

# Bibliography

- Albus, James S. *Brains, Behavior, and Robotics*. Peterborough: McGraw-Hill, 1981.
- Alexy, Robert. *A Theory of Legal Argumentation*. Oxford: Clarendon Press, 1989.
- Allen, Derek. 'Attributed Favourable Relevance and Argument Evaluation.' *Informal Logic*, 18 (1996): 183-201.
- Anderson, Alan Ross and Nuel D. Belnap, Jr. *Entailment: The Logic of Relevance and Necessity*. Princeton: Princeton University Press, 1975.
- Aristotle. *The Works of Aristotle Translated into English*. Ed. W. D. Ross. Oxford: Oxford University Press, 1928.
- . *On Sophistical Refutations*. Trans. E. S. Forster. Cambridge: Harvard University Press, 1928.
- . *Rhetoric*. Trans. J. H. Freese. Cambridge: Harvard University Press, 1937.
- . *Topica*. Trans. E. S. Forster. Cambridge: Harvard University Press, 1939.
- . *Posterior Analytics*. Trans. Huh Tredernick. Cambridge: Harvard University Press, 1939.
- Arnauld, Antoine. *The Art of Thinking (Port Royal Logic)*. 1662. Trans. James Dickoff and Patricia James. Indianapolis: Bobbs-Merrill, 1964.
- Ashley, Kevin D. and Vincent Alevan. "Generating Dialectical Examples Automatically." *Proceedings of the Tenth National Conference on Artificial Intelligence*. Cambridge: AAI Press, 1992. 654-60.
- . "A Logical Representation for Relevance Criteria." *Topics in Case-Based Reasoning*. Ed. S. Weiss, K. D. Althoff, and M. Richter. Berlin: Springer, 1994: 338-52.
- Ball, Vaughn C. "The Myth of Conditional Relevancy." *Georgia Law Review* 14 (1980): 435-69.
- Barr, Avron and Edward A. Feigenbaum. *The Handbook of Artificial Intelligence*. Vol. 1. Los Altos: Morgan Kaufmann Inc., 1981.
- Barth, Else M. and Erik C. Krabbe. *From Axiom to Dialogue*. De Gruyter, 1982.
- Beardsley, Monroe C. *Practical Logic*. New York: Prentice-Hall, 1950.
- Bentham, Jeremy. *The Works of Jeremy Bentham*. Ed. John Bowring 7 vols.. New York: Russell and Russell, 1962.
- Berg Jonathan. "The Relevant Relevance." *Journal of Pragmatics* 16 (1991): 411-25.
- Blair, J. Anthony. "Premissary Relevance." *Argumentation* 6 (1992): 203-17.
- Bonevac, Daniel. *The Art and Science of Logic*. Mountain View: Mayfield Publishing Co., 1990.

- Bowles, George. "Propositional Relevance." *Informal Logic* 12 (1990): 65-77.
- Bradshaw, Kenneth and David Pring. *Parliament & Congress*. Austin: University of Texas Press, 1972.
- Broad, William and Nicholas Wade. *Betrayers of the Truth*. New York: Simon & Schuster, 1982.
- Carberry, Sandra. *Plan Recognition in Natural Language Dialogue*. Cambridge: MIT Press, 1990.
- Carlson, Lauri. *Dialogue Games: An Approach to Discourse Analysis*. Dordrecht: Reidel, 1983.
- Castell, Alburey. *A College Logic*. New York: Macmillan, 1935.
- Chase, Stuart. *Guides to Straight Thinking*. New York: Harper and Row, 1956.
- Choo, Andrew L.T. "The Notion of Relevance and Defence Evidence." *The Criminal Law Review*, 1 Feb. 1993, 114-26.
- Cicero, Marcus Tullius. *De Inventione*. c. 91 B.C. Trans. H. M. Hubbell. London: William Heinemann, 1949.
- Clark, Romane and Paul Welsh. *Introduction to Logic*. Princeton: D. Van Nostrand, 1962.
- Copi, Irving M. *Introduction to Logic*. 3rd ed. New York: Macmillan, 1968.
- Copi, Irving M. and Carl Cohen. *Introduction to Logic*. 8th ed. New York: Macmillan, 1990.
- Creighton, James Edwin. *An Introductory Logic*. New York: MacMillan, 1904.
- Damaska, Mirjan R. *Evidence Law Adrift*. New Haven: Yale University Press, 1997.
- Damer, T. Edward. *Attacking Faulty Reasoning*. Belmont: Wadsworth, 1980.
- Dascal, Marcelo. "Conversational Relevance." *Journal of Pragmatics* 1 (1977): 309-28.
- Donohue, William A. "Development of a Model of Rule Use in Negotiation Interaction." *Communication Monographs* 48 (1981): 106-20.
- Engel, S. Morris. *With Good Reason*. New York: St. Martin's Press, 1976.
- Ennis, Robert H. *Critical Thinking*. Upper Saddle River: Prentice-Hall, 1996.
- Epstein, Richard L. "Relatedness and Implication." *Philosophical Studies*, 36 (1979): 137-73.
- . *The Semantic Foundations of Logic*, vol. 1: *Propositional Logics*. Dordrecht: Kluwer, 1990.
- . *The Semantic Foundations of Logic: Predicate Logic*. New York: Oxford University Press, 1994.
- . *The Semantic Foundations of Logic: Propositional Logics*. 2nd ed. New York: Oxford University Press, 1995.
- Fearnside, W. Ward and William B. Holther. *Fallacy: The Counterfeit of Argument*. Englewood Cliffs: Prentice-Hall, 1959.
- Federal Rules of Evidence*. Available on the internet at either [www.courtrules.org/fre](http://www.courtrules.org/fre) or [www.law.corness.edu/rules/fre](http://www.law.corness.edu/rules/fre)

- Feteris, Eveline T. *Fundamentals of Legal Argumentation: A Survey of Theories of the Justification of Legal Decisions*. Dordrecht: Kluwer, 1999.
- Fikes, R. E. and N. J. Nilsson. "STRIPS: A New Approach to the Application of Theorem Proving to Problem Solving." *Artificial Intelligence* 2 (1971): 189-208.
- Fisher, Lillian S. "The Rules of Evidence." *Newsweek*, 29 Sept., 1986: 8.
- Fisher, R., and W. Ury. *Getting to Yes*. Boston: Houghton Mifflin, 1981.
- Franks, C. E. S. "The 'Problem' of Debate and Question Period." *The Canadian House of Commons*. Ed. John C. Courtney. Calgary: The University of Calgary Press, 1985. 1-19.
- Fowler, *Logic: Deductive and Inductive*. Oxford: Clarendon Press, 1895.
- Fraser, Alistair, G.A. Birch, and William F. Dawson. *Beauchesne's Rules and Forms of the House of Commons of Canada*. 5th ed. Toronto: Carswell, 1978.
- Freeman, James B. *Dialectics and the Macrostructure of Arguments*. Berlin: Foris, 1991.
- Goodwin, Jean. "Wigmore's Chart Method." *Informal Logic* 20 (2000): 223-43.
- Gorayska, Barbara and Roger Lindsay. "The Roots of Relevance." *Journal of Pragmatics* 19 (1993): 306-12.
- Govier, Trudy. *A Practical Study of Argument*. 3rd ed. Belmont: Wadsworth, 1992.
- Green, Romuald. "An Introduction to the Logical Treatise 'De Obligationibus': With Critical Texts of William of Sherwood (?) and Walter Burley." 2 vols. Diss. Université Catholique de Louvain, Belg., 1963.
- Grice, J. Paul. "Logic and Conversation," in *The Logic of Grammar*. Ed. Donald Davidson and Gilbert Harman. Encino: 1975, 64-75.
- Grosz, Barbara J. "Focusing and Description in Natural Language Dialogues." *Elements of Discourse Understanding*. Ed. B. Webber, A. Joshi, and I. Sag. Cambridge: Cambridge University Press, 1981. 85-105.
- Gulliver, P. H. *Disputes and Negotiations*. New York: Academic Press, 1979.
- Hamblin, Charles L. *Fallacies*. London: Methuen, 1970.
- . "Mathematical Models of Dialogue." *Theoria* 37 (1971): 130-55.
- Harary, Frank, *Graph Theory*. Reading: Addison-Wesley, 1969.
- Hastings, Arthur C. "A Reformulation of the Modes of Reasoning in Argumentation." Northwestern University Diss. 1963.
- Hibben, John Grier. *Logic: Deductive and Inductive*. New York: Charles Scribner's Sons, 1906.
- Hintikka, Jaakko. "Information-Seeking Dialogues: A Model." *Erkenntnis* 38 (1979): 355-68.
- . "The Logic of Information-Seeking Dialogues: A Model." *Konzepte der Dialektik*. Ed. Werner Becker and Wilhelm K. Essler. Frankfurt am Main: Vittorio Kostermann, 1981. 212-31.
- Hitchcock, David. "Review of Johnson." *Informal Logic* 18 (1996): 269-83.



- Hitchcock, David, Peter McBurney and Simon Parsons. "A Framework for Deliberation Dialogues." *Argument and Its Applications: Proceedings of the Fourth Biennial Conference of the Ontario Society for the Study of Argumentation (OSSA 2001)*. Ed. H. V. Hansen, C. W. Tindale, J. A. Blair, and R. H. Johnson, CD-ROM. Also available on Peter McBurney's web page at the University of Liverpool, Department of Computer Science: <http://www.csc.liv.ac.uk/~peter/>
- Hohmann, Hanns. "The Dynamics of Stasis: Classical Rhetorical Theory and Modern Legal Argumentation." *American Journal of Jurisprudence* 34 (1989): 171-97.
- . "The Nature of the Common Law and the Comparative Study of Legal Reasoning." *American Journal of Comparative Law* 38 (1990): 143-70.
- . "Stasis." *Encyclopedia of Rhetoric*. Ed. Thomas O. Sloane. New York: Oxford University Press, 2001. 741-45.
- Hurley, Patrick J. *A Concise Introduction to Logic*. 5th ed. Belmont: Wadsworth, 1994.
- . *A Concise Introduction to Logic*, 7th ed., Belmont: Wadsworth, 2000.
- Imwinkelried, Edward J. *Evidentiary Distinctions*. Charlottesville: Michie, 1993.
- Iseminger, Gary. "Is Relevance Necessary for Validity?" *Mind* 89 (1980): 196-213.
- Jacobs, Scott and Sally Jackson. "Relevance and Digressions in Argumentative Discussion: A Pragmatic Approach." *Argumentation* 6 (1992): 161-76.
- . "Speech Act Structure in Conversation." *Conversational Coherence: Form, Structure and Strategy*. Ed. Robert T. Craig and Karen Tracy. Beverly Hills: Sage, 1983, 47-66.
- James, George F. "Relevancy, Probability and the Law." *California Law Review* 29 (1941): 689-705.
- Jennings, Nicholas R. and Michael Wooldridge. "Applying Agent Technology." *Applied Artificial Intelligence* 9 (1995): 357-69.
- Jevons, W. Stanley. *Elementary Lessons in Logic*. London: MacMillan, 1878.
- Intelliware, Inc. *Experteach*. Los Angeles: 1986.
- Johnson, Ralph H. and J. Anthony Blair. *Logical Self-Defence*. 2nd ed. Toronto: McGraw-Hill Ryerson, 1983.
- Jonsen, Albert R. and Stephen Toulmin. *The Abuse of Casuistry: A History of Moral Reasoning*. Berkeley: University of California Press, 1988.
- Joseph, H. W. B. *An Introduction to Logic*. 2nd ed. Oxford: Clarendon Press, 1916.
- Josephson, John R. and Susan G. Josephson, *Abductive Inference: Computation, Philosophy, Technology*. New York: Cambridge University Press, 1994.
- Kearns, John T. *Using Language: The Structure of Speech Acts*. Albany: State University of New York Press, 1984.

- Kennedy, George. *The Art of Persuasion in Greece*. London: Routledge and Kegan Paul, 1963.
- Kienpointner, Manfred. *Alltagslogik [Everyday Logic]*. Stuttgart: Fromman-Holzboog, 1992.
- Krabbe, Erik C. W. "So What? Profiles of Relevance Criticism in Persuasion Dialogue." *Argumentation* 6 (1992): 271-83.
- . "Profiles of Dialogue as a 'Dialectical Tool,'" *Advances in Pragmatic-Dialectics*, Ed. Frans H. van Eemeren. Amsterdam: Sic Sat (2002):153-67.
- Krabbe, Erik C.W. "Metadialogues." *Proceedings of the Fifth ISSA Conference on Argumentation*, to appear, 2003.
- Kreyche, Robert J. *Logic for Undergraduates*. New York: Holt, Rinehart and Winston, 1961.
- Landon, James. "Character Evidence: Getting to the Root of the Problem through Comparison." *American Journal of Criminal Law* 24 (1997) 581-615.
- Latta, Robert and Alexander MacBeath. *The Elements of Logic*. 2nd ed. London: Macmillan, 1956.
- Leonard, David P. "In Defense of the Character Evidence Prohibition." *Indiana Law Journal* 73 (1998): 1161-1215.
- Levinson, Stephen C. "Some Pre-Observations on the Modelling of Dialogue." *Discourse Processes* 4 (1981): 93-116.
- Little, J. Frederick, Leo A. Groarke, and Christopher W. Tindale. *Good Reasoning Matters*. Toronto: McClelland and Stewart, 1989.
- Lodder, Arno R. *DiaLaw: On Legal Justification and Dialog Games*. Proefschrift: University of Maastricht, 1998.
- Mackenzie, Jim. "Why Do We Number Theorems?" *Australasian Journal of Philosophy* 58 (1980): 135-49.
- . "The Dialectics of Logic." *Logique et Analyse* 94 (1981): 159-77.
- . "Four Dialogue Systems." *Studia Logica* 49 (1990): 567-83.
- M. A. L. and N. S. "Buzzwords." *The Progressive*, 54 7 July 1990, 21.
- Marchionini, Gary. *Information Seeking in Electronic Environments*. Cambridge: Cambridge University Press, 1995.
- McCosh, James. *The Laws of Discursive Thought*. New York: Robert Carter and Brothers, 1879.
- McEvoy, Sebastian. "The Construction of Issues." *Special Fields and Cases: Proceedings of the Third ISSA Conference on Argumentation*. Ed. Frans H. van Eemeren, Rob Grootendorst, J. Anthony Blair, and Charles A. Willard, Amsterdam: Sic Sat, 1995. 52-60.
- McPeck, John E. *Critical Thinking and Education*. Oxford: Oxford University Press, 1981.
- Mey, Jacob L. "On Gorayska and Lindsay's Definition of Relevance." *Journal of Pragmatics* 23 (1995) 341-42.

- Michael, Jerome and Mortimer Adler. "The Trial of an Issue of Fact: 1." *Columbia Law Review* 34 (1934) 1224-1306.
- Mill, John Stuart. *A System of Logic*. 1843. London: Longmans, 1970.
- Mueller, Christopher B. and Laird C. Kirkpatrick. *Modern Evidence: Doctrine and Practice*. Boston: Little, Brown and Company, 1995.
- Nadeau, Ray. "Classical Systems of Stases in Greek: Hermagoras to Hermogenes." *Greek Roman and Byzantine Studies* 2 (1959) 53-71.
- . "Hermogenes on Stases: A Translation with an Introduction." *Speech Monographs* 31 (1964): 361-424.
- Nielsen, Flemming Steen. *Alfred Sidgwick's Argumentationtheorie*. Copenhagen: Museum Tusulanums Forlag, 1997.
- Park, Roger C. "Character Evidence Issues in the O. J. Simpson Case—Or Rationales of the Character Evidence Ban, with Illustrations from the Simpson Case." *University of Colorado Law Review* 67 (1996): 747-76.
- Pearl, Judea. *Heuristics: Intelligent Search Strategies for Computer Problem Solving*. Reading: Addison-Wesley, 1984.
- Peirce, Charles S. *Collected Papers of Charle Sanders Peirce*. "Elements of Logic" Vol. 2 and "Pragmatism and Pragmaticism." Ed. Charles Hartshorne and Paul Weiss. Cambridge: Harvard University Press.
- Prakken, Henry. "A Dialectical Model of Assessing Conflicting Arguments in Legal Reasoning." *Artificial Intelligence and Law* 4 (1996): 331-68.
- Prakken, Henry and Giovanni Sartor. "Modelling Reasoning with Precedents in a Formal Dialogue Game." *Artificial Intelligence and Law* 6 (1998): 231-87.
- Précis of Procedure (House of Commons: Canada)*. 2nd ed. Clerk of the House of Commons, Table Research Branch, 1987.
- Quintilian. *Institutio Oratoria* 4 vol. Trans. H. E. Butler. Cambridge: Harvard University Press, 1920.
- Read, Carveth. *Logic: Deductive and Inductive*. 4th ed. 1891. London, Simpkin, Marshall, Hamilton, Kent & Co., 1920.
- . "Dialogue Frames in Agent Communication." *Proceedings of the Third International Conference on Multi-Agent Systems*. Ed. Y. Demazeau. Place: IEEE Press, 1998. 246-53.
- . "Building Monologue." Paper. Third Meeting of the Ontario Society for the Study of Argumentation. Brock University in St. Catharines, Ontario, 13 May 1999. Proceedings of the 3rd OSSA Conference (OSSA '99), St. Catharines, Ontario.
- Reed, Chris and Glenn Rowe. "Araucaria Software for Puzzles in Argument Diagramming and XML." Technical Report, University of Dundee, 2001.
- Rescher, Nicholas. *Dialectics*. Albany: State University of New York Press, 1977.
- Roberts, Graham B. "Methodology in Evidence—Facts in Issue, Relevance and Purpose." *Monash University Law Review* 19 (1993) 68-91.

- Russell, Stuart and Peter Norvig. *Artificial Intelligence: A Modern Approach*. Upper Saddle River: Prentice-Hall, 1995.
- Salmon, Wesley C. *Logic*. Englewood Cliffs: Prentice-Hall, 1968.
- Schamber, Linda. "Relevance and Information Behavior." *Annual Review of Information Science and Technology* 29 (1994): 3-48.
- Schamber, Linda and Michael Eisenberg. "On Defining Relevance." *Journal of Education for Library and Information Science* 31 (1991): 238-53.
- Schamber, Linda, Michael Eisenberg and Michael Nilan. "A Re-Examination of Relevance: Toward a Dynamic, Situational Definition." *Information Processing and Management* 26 (1990): 755-76.
- Schegloff, Emanuel A. "Presequences and Indirection." *Journal of Pragmatics* 12 (1988): 55-62.
- Schiller, Ferdinand and Canning Scott. *Formal Logic*. London: Macmillan, 1912.
- . *Logic for Use*. London: G. Bell & Sons, 1929.
- Schum, David A. *Evidential Foundations of Probabilistic Reasoning*. New York: John Wiley and Sons, 1994.
- Sidgwick, Alfred. *Elementary Logic*. Cambridge: Cambridge University Press, 1914.
- Spencer-Smith, Richard. *Logic and Prolog*. New York: Harvester-Wheatsheaf, 1991.
- Sperber Dan and Deidre Wilson. *Relevance: Communication and Cognition*. Cambridge: Harvard University Press, 1986.
- Strong, John William, ed. *McCormick on Evidence*. 4th ed. St. Paul: West Publishing Co., 1992.
- Tracy, Karen. "On Getting the Point: Distinguishing Issues from Events, An Aspect of Conversational Coherence." *Communication Yearbook* 5 (1982): 279-301.
- Twining, William. *Theories of Evidence: Bentham and Wigmore*. London: Weidenfeld and Nicolson, 1985.
- Van Eemeren, Frans H. and Rob Grootendorst. *Speech Acts in Argumentative Discussions*. Dordrecht: Foris, 1984.
- . "Fallacies in Pragma-Dialectical Perspective." *Argumentation* 1 (1987) 283-301.
- . *Argumentation, Communication and Fallacies*. Hillsdale: Lawrence Erlbaum, 1992.
- . "Relevance Reviewed: The Case of *Argumentum ad Hominem*." *Argumentation* 6 (1992a) 141-59.
- Vreeswijk, Gerard A. W. "Abstract Argumentation Systems." *Artificial Intelligence* 90 (1997) 225-79.
- Walton, Douglas N. *Topical Relevance in Argumentation*. Philadelphia: John Benjamins Publishing Co., 1982.
- . *Informal Logic*. Cambridge: Cambridge University Press, 1989.
- . *Question-Reply Argumentation*. New York: Greenwood Press, 1989.

- . *Practical Reasoning*. Savage: Rowman and Littlefield, 1990.
- . *Plausible Argument in Everyday Conversation*. Albany: State University of New York Press, 1992.
- . *The Place of Emotion in Argument*. University Park: The Pennsylvania State University Press, 1992.
- . *A Pragmatic Theory of Fallacy*. Tuscaloosa: University of Alabama Press, 1995.
- . *Arguments from Ignorance*. University Park: The Pennsylvania State University Press, 1996.
- . *Argumentation Schemes for Presumptive Reasoning*. Mahwah, N.J.: Lawrence Erlbaum, 1996.
- . *Argument Structure: A Pragmatic Theory*. Toronto: University of Toronto Press, 1996.
- . "The Straw Man Fallacy." *Logic and Argumentation*. Ed. Johan van Benthem, Frans H. van Eemeren, Rob Grootendorst and Frank Veltman. Amsterdam: Royal Netherlands Academy of Arts and Sciences, North-Holland, 1996. 115-128.
- . *The New Dialectic*. Toronto: University of Toronto Press, 1998.
- . "Dialectical Relevance in Persuasion Dialogue." *Informal Logic* 19 (1999): 119-43.
- . *Legal Argumentation and Evidence*, University Park, Pennsylvania: Penn State Press, 2002.
- Walton, Douglas N. and Lynn M. Batten. "Games, Graphs and Circular Arguments." *Logique et Analyse* 106 (1984): 133-64.
- Walton, Douglas N. and Erik C. W. Krabbe. *Commitment in Dialogue*. Albany, State University of New York Press, 1995.
- Walton, R. E. and R. B. McKersie. *A Behavioral Theory of Labor Negotiations*. New York: McGraw-Hill, 1965.
- Watts, Isaac. *Logick: Or, The Right Use of Reason in the Enquiry after Truth* Rev. ed. 1725. London: A. Millar, W. Cater and G. Robson, 1797.
- Werkmeister, W. H. *An Introduction to Critical Thinking*. Lincoln: Johnson Publishing Co., 1948.
- Whately, Richard. *Elements of Logic*. 9th ed. 1826. London: Longmans, Green, Reader and Dyer, 1870.
- Wigmore, John H. *The Principles of Judicial Proof*. Boston: Little, Brown and Co. 1913.
- . *The Principles of Judicial Proof*. Boston: Little, Brown and Co., 1931.
- . *A Student's Textbook of the Law of Evidence*. Brooklyn: The Foundation Press, 1935.
- . *Evidence in Trials at Common Law*. Vol. 1a, Ed. Peter Tillers. Boston: Little, Brown and Co., 1983.
- Wilensky, Robert. *Planning and Understanding: A Computational Approach to Human Reasoning*. Reading, Mass.: Addison-Wesley, 1983.

- William of Sherwood. *Introduction to Logic*. 1267. Trans. Norman Kretzmann. Minneapolis: University of Minnesota Press, 1966.
- Woods, John. "Sunny Prospects for Relevance?" *New Essays in Informal Logic*. Ed. Ralph H. Johnson and J. Anthony Blair. Windsor: Informal Logic Press, 1994. 82-92.
- Wooldridge, Michael and Nicholas Jennings. "Intelligent Agents: Theory and Practice." *The Knowledge Engineering Review* 10 (1995): 115-152.
- Yarmey, A. Daniel. *The Psychology of Eyewitness Testimony*. New York: The Free Press, 1979.

*This page intentionally left blank*

# Author Index

## A

Adler, Mortimer, *255n, 260*  
Albus, James S., 175  
Aleven, Vincent, *178, 258*  
Alexy, Robert, 164  
Allen, Derek, 99  
Anderson, Alan Ross, *95*  
Aristotle, 32, 33, 34, 145, 146  
Arnauld, Antoine, 47, 48  
Ashley, Kevin D., *178, 258*

## B

Ball, Vaughn C., *255n, 260*  
Barr, Avron, *173*  
Barth, Else M., *162*  
Batten, Lynn M., *118, 119, 206, 179n*  
Beardsley, Monroe C., 261, 263  
Belnap, Nuel D. Jr., *95*  
Bentham, Jeremy, 273  
Berg Jonathan., 114, 115, 131, 171n  
Birch, G. A., *248*  
Blair, J. Anthony, *23, 74, 75, 76, 84, 127, 171n, 223*  
Bonevac, Daniel, 22, 84  
Bowles, George, 98  
Bradshaw, Kenneth, *285*  
Broad, William, *145, 145n*

## C

Carberry, Sandra, 131, 143, 144, 145, 178, 179  
Carlson, Lauri, 162  
Castell, Alburey, 23, 68, 69, 82, 218  
Chase, Stuart,  
Choo, Andrew L.T., 10  
Cicero, Marcus Tullius, 41  
Clark, Romane, 71  
Cohen, Carl, *4, 16, 99, 102, 103*  
Copi, Irving M., *4, 5, 6, 9, 16, 99, 102, 103, 221, 222*

Creighton, James Edwin, 65, 218

## D

Damaska, Mirjan R., 273  
Damer, T. Edward, 71, 72, 73, 83, 84  
Dascal, Marcelo, 114, 128  
Dawson, William F., *248*  
Donohue, William A., 138

## E

Eisenberg, Michael, *133, 133*  
Engel, S. Morris, 16  
Ennis, Robert H., *179n*  
Epstein, Richard L., 95, 97, 135

## F

Fearnside, W. Ward, 69, 70  
Feigenbaum, Edward A., *173*  
Feteris, Eveline T., 165  
Fikes, R. E., *143*  
Fisher, Lillian S., 268  
Fisher, R., *138*  
Fowler, Thomas, 63, 65, 66  
Franks, C. E. S., 284  
Fraser, Alistair., *248*  
Freeman, James B., 116, 119, 155, 163

## G

Goodwin, Jean., 263  
Gorayska, Barbara, *143n*  
Govier, Trudy, 77, 78, 79  
Green, Romuald, 45, 46  
Grice, J. Paul, 111, 112, 114, 125n, 128, 128n  
Groarke, Leo A., 23, 24  
Grootendorst, Rob, 79, 125, 128, 129, *129n, 130, 151, 168, 169*  
Grosz, Barbara J., 144



Gulliver, P. H., 138

## H

Hamblin, Charles L., xiii, 17, 32,  
33, 34, 42, 44, 45, 45n, 47, 61,  
62, 104, 136, 146n, 162, 194,  
205

Harary, Frank., 116, 117

Hastings, Arthur C., 155

Hibben, John Grier, 11, 12, 66, 218

Hintikka, Jaakko, 131, 162

Hitchcock, David, 99, 141

Hohmann, Hanns, 11, 35, 37, 202

Holther, William B., 69, 70

Hurley, Patrick J., 16, 17, 80, 81,  
82, 84, 99, 115, 116, 182, 225

## I

Imwinkelried, Edward J., 256

Intellware, Inc., 172

Iseminger, Gary, 95n

## J

Jackson, Sally, 138, 197

Jacobs, Scott, 138, 197

James, George F., 255n, 260

Jennings, Nicholas R., 205, 206

Jevons, W. Stanley, 62, 218

Johnson, Ralph H., 23, 74, 75, 77,  
84, 223

Jonsen, Albert R., 41

Joseph, H. W. B., 182n

Josephson, John R., 274

Josephson, Susan G., 274

## K

Kearns, John T., 30

Kennedy, George, 35, 36, 37, 176

Kienpointner, Manfred, 155, 180,  
236

Kirkpatrick, Laird C., 256

Krabbe, Erik C. W., 126, 130n,  
136, 147, 148, 148n, 150, 151,

162, 167, 185, 186n, 189, 194,  
194, 196, 205, 209, 280  
Kreyche, Robert J., 82, 83

## L

Landon, James, 19

Latta, Robert, 64

Leonard, David P., 18

Levinson, Stephen C., 197

Lindsay, Roger, 143n

Little, J. Frederick, 23, 24

Lodder, Arno R., 201

## M

MacBeath, Alexander, 64

Mackenzie, Jim., 146n, 150, 162,  
205

Marchionini, Gary, 133

McBurney, Peter, 141

McCosh, James, 55, 56

McEvoy, Sebastian, 271

McKersie, R. B., 137, 138, 138

McPeck, John E., 8

Mey, Jacob L., 143n

Michael, Jerome, 255n, 260

Mill, John Stuart, 55

Mueller, Christopher B., 256

## N

Nadeau, Ray., 36

Nielsen, Flemming Steen, 58

Nilan, Michael, 133

Nilsson, N. J., 143

Norvig, Peter, 167, 172, 172n, 174,  
175, 203

## P

Park, Roger C., 19

Parsons, Simon, 141

Pearl, Judea, 121, 174

Peirce, Charles S.,

Prakken, Henry, 201, 201

Pring, David, 285

## Q

Quintilian, 36, 38-39, 40, 41, 176

## R

Read, Carveth, 66, 67, 218  
 Reed, Chris, 119, 155, 189, 190  
 Rescher, Nicholas, 162  
 Roberts, Graham B., 41 255, 256,  
 269, 270  
 Rowe, Glenn, 119  
 Russell, Stuart, 167, 172, 172*n*,  
 174, 175, 203

## S

Salmon, Wesley C.,  
 Sartor, Giovanni, 201  
 Schamber, Linda, 133, 133, 134,  
 134*n*  
 Schegloff, Emanuel A., 196  
 Schiller, Ferdinand Canning Scott,  
 57, 58  
 Schum, David A., 119, 265, 276  
 Sidgwick, Alfred, 59  
 Spencer-Smith, Richard, 173  
 Sperber, Dan, 131  
 Strong, John William, ed., 256, 257

## T

Tindale, Christopher W., 23, 24  
 Toulmin, Stephen, 41  
 Tracy, Karen, 168  
 Twining, William, 99, 255*n*, 259,  
 274

## U

Ury, W., 138

## V

Van Eemeren, Frans H., 79, 125,  
 128, 129, 129*n*, 130, 151, 168,  
 169  
 Vreeswijk, Gerard A. W., 201

## W

Wade, Nicholas, 145, 145*n*  
 Walton, Douglas N., xv, 2, 22, 44,  
 56, 77, 95, 98, 105, 116, 117,  
 118, 118, 119, 119, 125, 126,  
 126, 130*n*, 130, 132, 136, 136,  
 142, 147, 148, 148, 148*n*, 151,  
 155, 163, 179*n*, 180, 182, 185,  
 189, 194, 194, 196, 196*n*, 203,  
 205, 206, 209, 213, 236, 237*n*,  
 241, 242, 254  
 Walton, R. E., 138  
 Watts, Isaac, 49, 50, 51  
 Welsh, Paul, 71  
 Werkmeister, W. H., 69  
 Whately, Richard, 51, 52, 53, 54,  
 219, 263  
 Wigmore, John H., 20, 20*n*, 27,  
 255*n*, 260, 261, 263  
 Wilensky, Robert, 143, 179  
 William of Sherwood, 42, 43  
 Wilson, Deidre, 131  
 Woods, John, 99  
 Wooldridge, Michael, 205, 206

## Y

Yarmey, A. Daniel, 280

*This page intentionally left blank*

# Subject Index

## A

- Abduction, 157
- Abortion case (4.4), 106-107, 140
- Abortion/Caesarean case (6.4), 188
- Abuse of welfare case (3.24), 80, 224-26, 228, 229
- Ad baculum*,
  - argument, 108, 110, 187, 235-36, 239
  - fallacy, 15-16, 151, 186, 239-40
  - relevant, 17
- Ad hominem*,
  - argument, 106, 206, 221, 232, 235-36
    - circumstantial, 107
    - dialectically relevant, poisoning the well, 107, 140
    - relevant in law, 18, 238, 272
  - attack, 138, 140, 238-39
    - abusive, 107
    - fallacy, 15
    - tu quoque*, 65
- Ad misericordiam*,
  - argument, 101, 235-36, 240
  - fallacy, 15-16
- Ad populum*, 233, 235-36
  - argument, 102, 104
  - fallacy, 15-16
  - relevant, 17
- Ad rem*, 67
- Ad verecundiam*, 206
- Adjacency pair, 197
- Adler, Mortimer, 260
- Advantageous exchange case (2.5), 53
- Advertisement,
  - commercial, 102-103, 164, 164
- Agency, 206
- Agenda, 25-26
- Agent, 237
  - defined, 205-06
  - goal of, 175
- Aleven, Vincent, 178, 258, 259
- Alexy, Robert, 164
- Allen, Derek, 99
- Almsgiving case (3.4), 67, 68, 86
- Anderson, Allan Ross, 95
- Antiabortion case (3.11), 73-74
- Apparentia*, 220, 221, 242
- Appeal,
  - emotional, 39, 101-103, 105, 108, 231
  - irrelevant, 73
  - to fear, 108
  - to pity, 17
- Aquinas, Thomas, 45
- Araucaria*, 119-20, 179, 180, 183-85, 227
  - diagram, 184
- Argument,
  - circular, 91
  - convergent, 278
  - criteria for logically good, 224
  - diverted, 22
  - extrapolation, 134, 178, 227
  - linked, 278
  - logically good, 224
  - prejudicial power of, 6
  - projector, 180-81, 185
  - stages of, 128-29
  - validity, 91
  - weak, 92, 101
- Argument diagram, 117-18, 158, 193-95, 207, 255, 261, 263-64, 264-68
  - directed graph, 116, 163, 265
- Argument from analogy, 180, 203
- Argument from consequences, 184
- Argumentation, chaining of, 163, 172, 174, 255, 274
  - backward, 172, 173, 204
  - composition, 179
  - forward, 172-73, 199, 204, 242
  - scheme, 199, 203, 238
  - weak link, 277
- Aristotle, 43, 47, 61, 140, 142, 144, 218, 222
  - fallacies of, 31, 33, 42, 44, 67, 235, 240, 245
  - refutation, 32, 42
- Arnauld, Antoine, 47-49, 54

Artificial intelligence (AI), 131,  
133, 136, 142, 172, 174, 176,  
204, 205, 207, 208, 255  
  planning, 142-44, 175, 179,  
  227  
  plan recognition, 178-79  
Ashley, Kevin D., 178, 258, 258  
Atrocious fraud case (2.4), 53, 54,  
56, 220  
Attempted prison escape case, 257

## B

Batten, Lynn, 119  
Bananas are yellow case (4.1), 91,  
97-98  
Bank employee/prison case (4.6),  
111-12, 114  
Barr, Avron, 173  
Basketball game case (3.15), 77-78  
Bayesian approach, 277  
Beardsley, Monroe, 261, 263  
Belnap, Nuel D. Jr., 95  
Bentham, Jeremy, 99, 255, 259,  
273, 274  
  Natural System, 274-75  
Berg, Jonathan, 115, 131  
Bias, 105  
Bike path case, 148  
Blair, Anthony J., 23, 74-77, 84,  
127, 223, 228, 229  
Bonevac, Daniel, 22-23  
Bowles, George, 98-99  
Bradshaw, Kenneth, 285  
Burden of proof, 9, 128, 165, 237,  
249, 286

## C

Carberry, Sandra, 131, 144, 145,  
178  
Castell, Alburey, 23, 68, 71, 82  
Character, 18-19  
  attack, 18  
Charles I case (3.5) 67, 68c  
Chernobyl death case (3.18), 78  
Child education case (2.6), 53, 56  
Child education case (2.13), 56-57  
Child/spouse abuse case (5.1), 131  
Choo, Andrew L. T., 10

Church on Sunday case (3.9), 72,  
73, 210, 229, 245  
Church-goers case (3.2), 65  
Cicero, Marcus Tullius, 41  
Clark, Romane, 71  
Class action case (2.3), 52, 56  
Cohen, Carl, 99, 102-103  
  classification of fallacies, 16  
Commitment,  
  dark side, 185  
  weight of, 105  
Conclusion, interim, 183  
Concrete basement case (5.4), 147  
*Confirmatio*, 41  
Context, 12, 15  
Contradiction, 45  
Conversational implicature, 111  
Cooperative Principle (CP), 111,  
114-15  
Copi, Irving, 99, 102-103, 178,  
220-21, 234  
  analysis by, 6, 7, 9, 221, 222  
  classification of fallacies, 16  
  treatment of irrelevance, 4  
Corporate income tax case, 182-84  
Creighton, James Edwin, 65-66  
Crimes and death penalty case  
  (3.23), 80, 224-26, 228, 229  
Critical discussion, 180  
  argumentation stage, 129  
  ten rules for, 129  
  complex, 128  
  concluding stage, 130  
  confrontation stage, 128  
  goal of, 158  
  opening stage, 128-29, 152  
  simple, 128  
Currency conversion case, 193-94

## D

Damaska, Mirjan R., 273  
Damer, T. Edward, 71-74, 83, 210,  
229  
Dascal, Marcelo, 114, 128  
Decent housing case (1.2), 4-7, 9,  
10, 15, 30, 176, 178, 213, 222,  
227, 233, 234  
Deliberation dialogue, 14, 141,  
145, 164  
  focusing, 144

goal of, 160  
 relevance in, 143-44  
 Demonstration (*apodeixis*) (see Inquiry)  
*Displacement*, 148  
 Devil's advocate argument, 141  
 Dialogue,  
   basic types of, 135-37  
   frame, 189  
   profile of, 194  
   profile reconstruction, 195-98, 208  
 Dialogue on tipping, 126-27, 175  
 Digressions, 17, 38-41, 138  
   limited, 15  
 Disputation, medieval method of, 45  
 Distractions, 17  
 Distributive bargaining, 137-38  
 Dog beating case (2.8), 53  
 Doll hazards case (3.12), 74, 228, 229  
 Donohue, William A., 138

## E

Eastern Airlines case (5.5), 149  
 Eisenberg, Michael, 133  
 Embedding, 147, 153, 160, 163, 191-92, 198-200, 211  
 Engel, S. Morris, 16  
 Enthymemes, 158, 182, 186, 241  
 Epstein, Richard L., 95, 97, 135  
 Eristic dialogue, 139-41, 164  
 Euclidean geometry, 47, 146  
 Evidence, 69, 260  
   character, 18-19, 21, 272  
   chart, 261-62  
   defined, 157  
   forensic, 280  
   hard, 100  
   irrelevant, 69  
   objective, 15  
   probative, 273  
   relevant, 256, 257, 268-72  
   rules of, 11, 254  
 Evidential base, 180, 242  
 Evolution case (3.7), 69

## F

Factor, 258  
 Fallacy, 33  
   defined, 241  
   dual approach, 85-86  
   informal, 206  
   logical leap, 226  
   of ambiguity, 4  
   of arguing to the wrong point, 62, 218  
   of assigning irrelevant functions or goals, 83  
   of distortion (see also straw man), 83  
   of diversion, 69-71, 73, 83, 216, 234  
   of ignoring the issue, 61, 82  
   of irrelevance, 55, 232, 244  
     classification, 243  
     reason for occurrence, 216  
   of irrelevancy, 63  
   of irrelevant conclusions, 4, 23, 52, 61, 65, 71, 218  
   of irrelevant evidence, 68, 71  
   of irrelevant reason, 74  
   of irrelevant thesis, 68  
   of misconception of refutation, 16, 32-34, 43, 47, 48, 49, 51, 52, 61  
     defined, 34  
   of misdirected argumentation, 216-17, 228, 235  
   of missing the point, 61, 71-72, 73-74, 80, 82, 84, 210, 224, 225  
   of relevance, 4, 80  
   of shifting ground, 55, 63  
   of surreptitious conclusion, 66, 67  
   of wrong conclusion, 35, 105, 216, 218-19, 222-23, 241, 245  
   of *ignoratio elenchi*, 4, 11, 16, 235  
     Aristotle, 32, 47, 171, 219, 223, 240  
     Arnauld, 47-48  
     Clark and Welsh, described, 4, 11, 62  
     Hibben, 66  
     Schiller, 58

Sidgwick, 59  
 Watts, 49-50  
 Whately, 54  
 William of Sherwood, 42,  
     44  
 ignorance of refutation, 32, 49  
 red herring, 61, 69-71, 76, 216,  
     230-32, 242, 244  
     defined, 16-17, 24, 73, 81  
     diversionary type, 234  
     pettifogging type, 230,  
         234, 242  
     *secundum quid*, 33-34, 43-  
         44, 50, 104  
     straw man, 47, 54, 73, 82,  
         85, 235  
     contrasted with *ignoratio  
         elenchi*, 51  
     defined, 17, 23-24, 84  
 Fallacy of shifting ground case  
     (2.11), 55, 56  
 Fearnside, W. Ward, 69-71, 230,  
     234  
*Federal Rules of Evidence* (FRE),  
     202, 221, 226,, 237, 247, 254-  
     55, 259, 275, 279  
     exclusionary rules, 272-73,  
         275  
     Rule 401, 20, 256  
     Rule 402, 20, 271  
     Rule 403, 20-21  
     Rule 404, 18-19, 21, 272  
     Rule 412, 272  
     Rule 608, 18  
 Feigenbaum, Edward A., 173  
 Feteris, Eveline T., 165  
 Filibuster (See Tactic)  
 Fisher, Lillian S., 268  
 Fisher, R., 138  
 Fowler, Thomas, 63, 65, 66  
 Francis Bacon case (2.12), 55-56  
 Franks, C.E.S., 284  
 Free will issue case (6.3), 186  
 Freeman, James B., 119, 155

## G

Gardenier, Barent, 285  
 Generalization, 104, 154  
*Glissement*, 106, 148  
 Goal, 188, 200, 286

Govier, Trudy, 77-80  
 Green, Romuald, 46  
 Green position case (1.6), 22  
 Grice, J. Paul, 125, 128, 197  
     relevance, 112, 114  
 Gricean conversational maxims,  
     38, 111-13, 125  
 Gricean implicature, 114, 127  
 Groarke, Leo A., 23-24  
 Grootendorst, Rob, 79, 125, 128-  
     30, 136, 151-52, 168  
 Grosz, Barbara J., 144  
 Gulliver, P.H., 138

## H

Hamblin, Charles L., 61-62, 104,  
     136  
     on *Port Royal Logic*, 47  
     refutation, 32-34  
     relevance, 17  
 Harary, Frank, 116  
     directed graphs, 116  
 Hastings, Arthur C., 155  
 Hearsay, 269  
 Herd concept, 104  
 Hermagoras of Temnos, 11, 28, 35,  
     48, 54, 57, 58, 176  
     relevance, 126  
 Hermogenes of Tarsus, 36  
 Heuristics, 121-22, 128, 174  
 Hibben, John Grier, 11-12  
 Hitchcock, David, 99, 141  
 Hitler essay, 156-57, 211-12  
 Holther, William B., 69-71, 230,  
     234  
 Horribleness of murder case (1.3),  
     9, 10-11, 30, 39, 41, 176, 178,  
     181, 185, 220-21, 227, 233  
 Hurley, Partick, J., 80-82, 84, 116,  
     231  
     classification of fallacies, 16,  
         225  
 Hypothesis, 145-46

## I

Immobilized car case (4.7), 112-13,  
     114  
*Indignatio*, 41

Inference,  
 deductively valid, 174  
 sequence of, 46  
 valid, 204  
 Information Retrieval Interaction  
 Model, 134  
 Information-seeking dialogue, 131,  
 191  
 celebrity interview, 132  
 computerized data base search,  
 goal of, 131  
 peirastic aspect of, 193  
 political interview, 132  
 relevance in, 144  
 Informational containment, 95  
 Inquiry, 49-50, 145-47  
 cumulative, 145  
 goal, 145  
 stages of, 146-47  
 Insufficiency, 224  
 Intensive care unit case (1.5), 13-  
 14, 15, 29  
 Interest, 139  
 Interest rates case (3.16), 78  
 Interlocutor, 191  
 Intersubjective testing procedure  
 (ITP), 152  
 Irrelevance (see also Relevance), 6,  
 217-18, 224, 250  
 defined, 38, 67, 236  
 dialectic, 236  
 Irrelevant conclusion case (3.1), 62  
 Issue, 138  
 general, 176  
 particular, 176

## J

Jackson, Sally, 138, 197  
 Jacobs, Scott, 138, 197  
 Jennings, Nicholas R., 206  
 Jevons, W. Stanley, 62-64, 65, 218  
 Joe's living case (6.5), 197  
 Jogging case (3.17), 78  
 Johnson, Ralph H., 23, 74-77, 84,  
 223, 228, 230  
 Jones' Boston Marathon case  
 (3.14), 77  
 Jonsen, Ralph H., 41  
 Josephson, John R., 274  
 Josephson, Susan G., 274

## K

Kienpointner, Manfred, 155, 180  
 Kirkpatrick, Laird C., 256  
 Knowledge base, 172, 173, 277  
 Krabbe, Eric C.W., 126, 136, 147-  
 48, 151, 196, 209  
 Kreyche, Robert J., 82-83

## L

*Laissez faire case* (3.6), 23, 68, 82  
 London,  
 law history, 19  
 Language, 32  
 Latin study case (3.3), 66  
 Latta, Robert, 64  
 Leap, 225, 228  
 Legal argumentation, 1, 18, 163-  
 64, 202  
 admissibility, 271  
 burden of proof, 9, 237  
 case differences, 259  
 continental law, 273  
 naturalistic thesis, 275  
*prima facie*, 272  
 relevance in, 1, 7-8, 20, 166,  
 254-59, 259, 279  
 rules of relevance, 8, 9-10, 202  
 stages in a criminal  
 prosecution, 281, 221  
 trial, purpose of, 279  
 trial rules, 267  
 Leiden train case (5.3), 142, 144  
 Leonard, David P., 18  
 Letter soliciting funds case (4.2),  
 101  
 Levinson, Stephen C., 197  
 Library hours case (1.1), 2-3, 15,  
 29  
 Little, J. Frederick, 23-24  
 Locke, John, 99, 259  
 Logic, deductive, 90  
 Low income housing (3.8), 71

## M

MacBeath, Alexander, 64  
 Mackenzie, Jim, 150  
 Marchionini, Gary, 133



Maxim of relation, 115  
 McBurney, Peter, 141  
 McCosh, James, 55-57  
 McEvoy, Sebastian, 271  
 McKersie, R.B., 137, 138  
 McPeck, John E., 8  
 Michael, Jerome, 260  
 Mill, John Stuart, 55  
 Mixed discourse, 163  
*Modus ponens*, 79, 172, 174, 180  
 Moldy fridge case (6.2), 173-74, 196  
 Move, 136  
 Mr. Smith case (4.2),  
 Mueller, Christopher B., 256  
 Multi-agent systems, 205, 206, 237, 264

## N

Natural catastrophes case (3.21), 78  
 Natural system of law, 255  
 Naturalistic thesis, 275  
 Negligent student case (1.4), 12  
 Negotiation dialogue, 135, 147  
   commitment in, 138  
   confrontation stage, 137  
   relevance in, 138  
   subtypes of,  
   union-management,  
 New York visits case (4.8), 112-13, 114  
 Newspaper reporters case (3.10), 72, 73, 213  
 Nicole, Pierre, 47  
 Nilan, Michael, 133  
 No action option case (1.7), 25-26  
 Norvig, Peter, 174

## O

Obligation game, 42-47  
 Obligation treatise, 46  
 Opponent, 44-47  
 Oratory, 38  
   deliberative, 36  
   forensic, 36

## P

*Parekbasis*, 41  
 Parsons, Simon, 141  
 Paul's driving test case (3.22), 79  
 Pearl, Judea, 121  
 Personal attack, 107  
 Persuasion dialogue, 126, 156, 191  
   commitments, 145  
   goal of, 159  
   goal of participant, 136  
   permissive (PPD), 189  
   relevance in, 126-30  
   requirements of, 126  
   rigorous (RPD), 189  
 Philosophy major case (3.28), 84  
*Phronesis* (see Reasoning, practical),  
 Pring, David, 285  
 Plato, 140  
 Plausibility values, 278  
 Point of view, 128  
 Political/Parliamentary debates, 1, 102, 163-64, 202, 239, 284  
   devaluation of, 284, 287  
   irrelevance in, 6  
   relevance in, 7-8, 248, 249, 251-54  
   rules of relevance, 1, 8, 29-30, 202, 247-51  
   stages of, 248  
 Political interview case (5.2), 132  
 Popular opinion, 104  
   value of, 104  
*Port Royal Logic*, 47  
 Porterhouse steak case (1.8), 27-28, 125  
*Positum*, 44, 45-46  
 Prejudice, 271  
 Premise,  
   missing, 183, 241  
   relevance of, 75  
 Presumption,  
   defeasible weight of, 100  
 Principle of Contradictory  
   Premises, 90, 91, 97  
 Probative weight, 99, 181, 217, 241, 257, 278  
   potential, 99  
 Property case (4.3), 105  
 Proposition, 78  
   abstract, 175

conditional, 172  
 evidentiary chain of,  
 non-abstract, 176

**Q**

Quarrel, 139  
 closing stage, 140  
 goal of, 160  
 personal, 106  
 purpose of, 139  
 relevance in, 139, 140  
 Questions,  
 critical, 193, 203, 237  
 definite or indefinite, 176, 177  
 general, 177  
 indirect, 132  
 Quintilian (Marcus Fabius  
 Quintilianus), 28, 36-37, 176,  
 185  
 digression, 39-40  
 stages, 38, 40

**R**

Read, Carveth, 66-68  
 Reasoning,  
 abductive, 173  
 backwards, 157  
 chain of, 208, 225  
 circular, 118  
 deductive, 157  
 errors of, 242  
 inductive, 157  
 natural language, 93  
 plausible, 278  
 practical, 142  
 structure of, 265  
 syllogistic, 44  
 Reed, Chris, 136, 155, 157, 189-90,  
 192  
 Refutation,  
 defined, 32, 42  
 failed, 223  
 sophistical,  
 Relatedness logic, 89, 99, 135  
 Relevance, 75-76, 105, 235  
 cognitive, 134  
 contextual, 24  
 conversational, 107  
 defined, 46, 77, 97, 98, 131,  
 133, 209, 271  
 dialectical, 28, 46, 169, 205,  
 208, 217, 260  
 evaluative, 169  
 evaluating, 7, 11, 163, 171,  
 181-82  
 failure of, 16, 17  
 gatekeeping function of, 2  
 general, 13, 14  
 interpersonal, 141  
 interpretative, 168  
 irrelevance, 77, 168  
 judging, 201-202  
 legal, 10, 20-21, 259, 268, 279  
 exclusionary rules, 272  
 logical, 21, 259, 260, 268  
 main fallacies of, 16  
 material, 5-6, 12, 28, 205, 230,  
 254, 258, 271  
 described, 14  
 failure of, 13  
 importance of, 29  
 negative, 77  
 negotiation dialogue, 138  
 new dialectical theory of, 215,  
 227, 243  
 normative, 124, 169, 197  
 potential, 5  
 positive, 77  
 probative, 10, 77, 127  
 premissary, 127  
 quarrel, 139  
 rules of, 6, 8  
 institutionalized procedural,  
 19-20  
 semantic,  
 situational, 134  
 topical, 5, 10, 12, 95, 97, 127,  
 254  
 wastebasket, 235, 236, 245  
 Relevance logics, 94  
 Relief of the poor case (2.7), 53,  
 219  
 Republican senators case (3.27), 83  
 Resistance to government case  
 (2.9), 54  
 Respondent, 44  
 Right of private judgment in  
 religion, (2.10), 54  
 Roberts, Graham B., 41, 255-56,  
 269

RSA triangle, 223-24  
 Rules of dialogue, 207  
   commitment, 136, 209  
   locution, 136, 209  
   structural, 136, 209  
   win-loss, 136, 209  
 Russell, Stuart, 174

## S

Sacco and Vanzetti case, 265-67  
 St. Paul case (2.1), 50  
 Scare tactics, 108  
 Schamber, Linda, 133-34  
 Schum, David A., 119, 265  
 Schegloff, Emanuel A., 196-97  
 Schiller, Ferdinand Canning Scott,  
   57-59  
 Science of Proof, 255, 260, 267,  
   275, 279  
 Section Head case (4.5), 108-109  
 Search tree, 174  
 Semantic approach, 31, 87  
 Shift, 187-88  
   covert, 110  
   deceptive, 149  
   dialectical, 147-48, 194, 240  
   subtle, 240  
   from critical discussion,  
   from deliberation, 150, 160  
   from persuasion dialogue, 159,  
   160, 161, 201, 238  
   illicit, 150-51, 186, 242  
   licit, 150, 158  
   unilateral, 151  
 Sidgwick, Alfred, 58-59  
 Simpson, O.J., 19  
 Slippery slope argument, 159-60  
 Smith's Chinese politics case  
   (3.19), 78  
 Sophism, 242  
 Spencer-Smith, Richard, 173  
 Sperber, Dan, 131-32  
 Stages of dialogue  
   argumentation, 136  
   closing, 136  
   confrontation, 136  
   opening, 136  
*Stasis*, 11, 36-37, 48, 58, 176, 279

STRIPS system, 143  
 Student essay on Hitler case,  
 Strong, John William, 256, 257  
 Student major case (6.1), 168-69  
 Subject-matter, 95-97  
 Syllogism, 32, 35, 46, 57, 58, 240-  
   41  
 Sylvania light bulb case (3.26), 81,  
   231, 242

## T

Tactics,  
   deceptive, 106  
   digression, 40  
   distraction, 221, 230  
   filibuster, 3, 282, 285  
   red herring, 239, 285  
   sophistical, 24, 53, 232  
   surprise, 19  
   tricky, 217  
 Tainted tuna case, 254  
 Tasters Choice coffee case (3.25),  
   81, 231, 242  
 Theophrastus' Rule, 278  
 Thesis, 101, 105-106, 108  
 Threat, 239  
   covert, 108,-109  
   inappropriate, 186  
   indirect, 109  
   irrelevant, 187  
   overt, 109  
 Tillers, Peter, 255, 260, 283  
 Tindale, Christopher W., 23-24  
 Toulmin, Stephen, 41  
 Tracy, Karen, 168  
 Trade bill case (3.29), 84  
 Trade secrets law, 258  
 Train case, 251-54  
 Transitive, 96, 97  
 Truth-functional connective, 94  
 Twining, William, 259  
   dialogue summary, 274

## U

Ury, W. 138

## V

- Validity
  - defined, 90-91
- Van Eemeren, 79, 125, 128-29, 136, 151-52, 168
- Verbal game, 57
- Veracity, 206

## W

- Walton, Douglas, 22, 56, 119, 125-26, 138, 147-48, 151, 180, 209, 213, 241
  - profile of dialogue tool, 196
  - types of dialogues, 136-37
- Walton V. The Queen case (8.3), 269-71, 283
- Warrant, 237
- Watts, Isaac, 49-51
- Welsh, Paul, 71
- Werkmeister, W.H., 69
- Whately, Richard, 51-55, 219, 263, 264

- Widow law suit case (8.2), 268-69, 272, 282
- Wigmore, John H., 27-28, 125, 261, 267
  - relevance, 99, 280
  - science of proof, 267, 275
  - source of irrelevance, 27
  - theory of evidence, 255, 259-60
- William of Sherwood, 42-44, 45, 46
- Wilson, Deidre, 131-32
- Windsor case (3.13), 76-77, 230
- Wine exhilaration case (2.2), 50
- Witness testimony, 165, 275
- Women's sensitivity case (3.20), 78
- Woods, John, 99
- Wooldridge, Michael, 206

## Y

- Yarmey, A. Daniel, 280
- Yes-no questions, 44, 45