

# THE STONE

THE JOURNAL OF THE PHILOSOPHERS OF NATURE

© 2001, TRIAD PUBLISHING. ALL RIGHTS RESERVED.

VOLUME 1

1990 - 1995

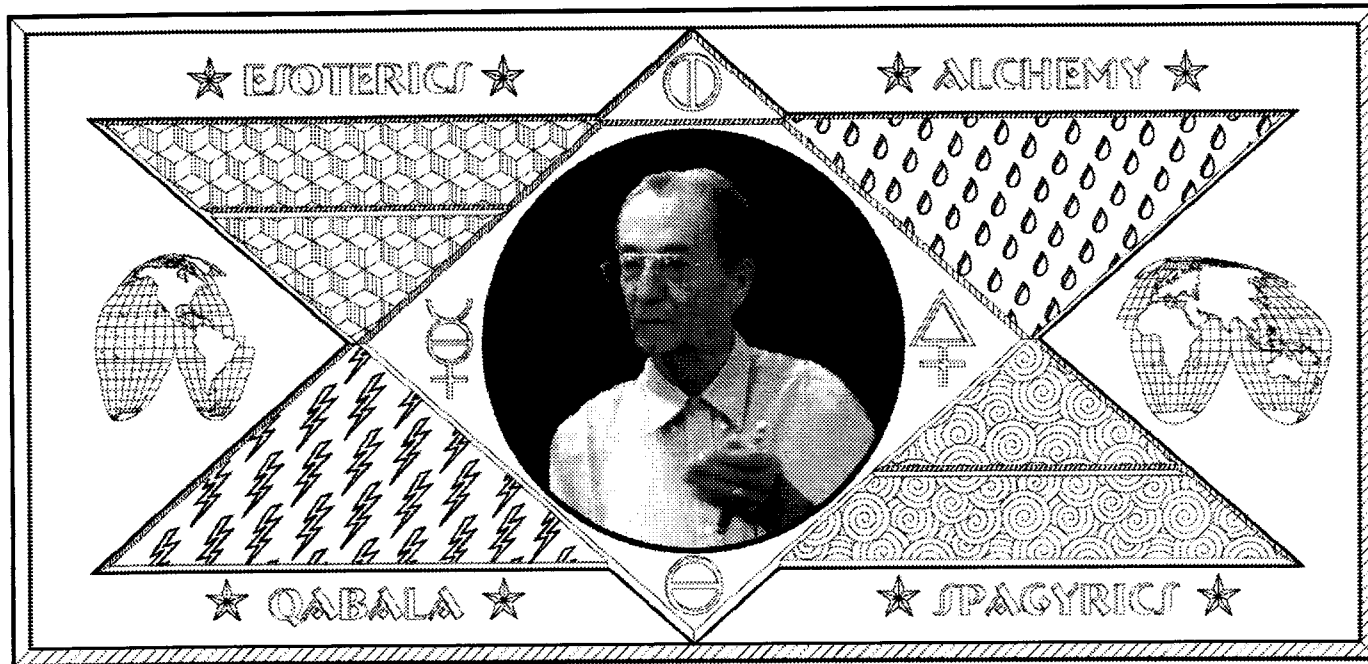

## VOLUME 1 OF 3

- ♀ Issue 1, Fall 1990
- ♀ Issue 2 - 3, Winter 1990, Spring 1991
- ♀ Issue 4, Fall 1991
- ♀ Issue 5, Spring 1992
- ♀ Issue 6, Fall 1992
- ♀ Issue 7, Early Spring 1993
- ♀ Issue 8, Late Summer 1994
- ♀ Issue 9 - 10, March - July 1994
- ♀ Issue 11, November 1994
- ♀ Issue 12, March 1995
- ♀ Issue 13, July 1995
- ♀ Issue 14, November 1995
- ♀ Cover Photograph: Jean Dubuis

## THE STONE

The Philosophers of Nature was a research and educational association that existed in the United States from 1987 until 1999. The focus of the organization was on the Western esoteric practice, with a particular emphasis on practical work in Alchemy and Qabala. "The Stone" was the newsletters for members and associates of The Philosophers of Nature.

It is reprinted in 3 volumes by Triad Publishing.

## TRIAD PUBLISHING

P.O. Box 116, Winfield, IL 60190 USA

Email: [info@triad-publishing.com](mailto:info@triad-publishing.com) [www.triad-publishing.com](http://www.triad-publishing.com)

---

---

# THE STONE

THE JOURNAL OF THE PHILOSOPHERS OF NATURE

© 2001, TRIAD PUBLISHING. ALL RIGHTS RESERVED.

---

Dear Reader,

As a 'charter member' of The Philosophers of Nature (back when it was LPN-USA), I had the great privilege of waiting for the first 16 issues of these newsletters to come to my mailbox. They were great, right from the start, or at least I thought so. Never mind that desktop publishing was in its infancy, and that an affordable scanner was just a dream in 1990, this was a newsletter that did what it set out to do -- connect the few and far-between alchemists, qabalists, ceremonialists, astrologers and Hermeticists that were The Philosophers of Nature. Ken Miller was the editor for those 16 great issues; more than anyone, he gave The Stone a personality that the later caretakers would continue as well as we knew how.

Beginning with issue 17, I could no longer wait for The Stone to come to my mailbox, but was instead involved in the production of each issue, working with Editor-in-Chief Rick Grimes. We died a thousand deaths together dealing with the 2AM technical glitches that seemed to travel in herds at that time of day. Sometimes we were a little 'light' on material for an issue, a day or so before the deadline, so one of us would start writing an article. It was this sort of necessity that prompted me to write an article about a childhood hero, George Washington Carver.

As the organization grew, and the number of subscribers to the newsletter along with it, Vi and Norm Engel volunteered to take over the bi-monthly copying and mailing. Their doing so helped to keep The Stone and The Philosophers of Nature afloat for just a bit longer.

Today, the PON is no more. I hope that those of you, who read these issues of The Stone, will find something inspiring here, something that moves you into action. I think you will find that The Stone was the voice of some of the finest thinkers, innovators, and tinkerers of our times.

With best regards,



Russ House  
Triad Publishing



**IMPORTANT NOTE:** Many of the businesses that advertised in these issues are closed. Do not send money to any of the companies listed in these back issues unless you have contacted them first. These issues are complete as originally published, except that we often removed the last few pages of issues in the 3<sup>rd</sup> volume as they were advertising for publications from the PON that we ran repeatedly.

**TRIAD PUBLISHING**

P.O. Box 116, Winfield, IL 60190 USA

Email: [info@triad-publishing.com](mailto:info@triad-publishing.com) [www.triad-publishing.com](http://www.triad-publishing.com)



## IN THIS ISSUE

WHAT IS LPN-USA? .....2  
by *Bill Van Doren*.

Bill is the man who has made all of this possible, and we hear how it all began. Humble beginnings & ambitious goals.

NOTICE .....3

What can *The Stone* be? A request for your feedback.

UNIVERSALITY OF ALCHEMY.....3  
by *G. Rainsart*

(from LPN-France #24, 1985.)

A very brief dip into East Indian alchemy.

SPAGYRICS.....4  
by *Jean Dubuis*

(from LPN-France newsletter #24, 1985.)

A good introduction to the subject.

20TH CENTURY MASTERS  
ON THE PHYSICS OF  
ALCHEMICAL TRANSMUTATION ...8

This piece is edited by our member *Anthony M. House* and is largely a collection of quotes.

SPIRITUS ACETI OLEOSUS .....11  
by *Bernard Broujean*

(from LPN-France #24, 1985.)

An interesting experiment to be done after lesson #35 of the Metallic work.

Plus: "Quote of the Season," Tricks for the Lab, and the French Editorial. Enjoy, and remember to send in your submissions and ideas to Kenneth Miller, 405 West Washington St. #314, San Diego, CA 92103. Remember, all dues and questions about your membership should be addressed to LPN-USA, P.O.B. 11218, Boulder, CO 80301.

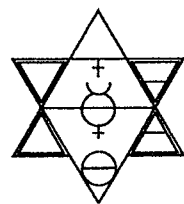
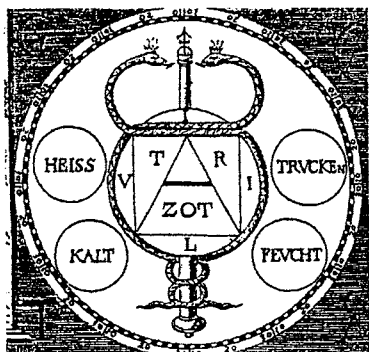

# The Stone

Vol. 1, No. 1

Fall 1990

## GREETINGS!

Here begins the first issue of *The Stone* which is about a million years late in getting out to you. Our original target publication date of January flew by, and since then it has been a comedy of errors for me to get this completed. However, we now have new systems that should insure the timely production of issues. We will begin a quarterly release beginning Fall 1990, mailings to be roughly timed with the equinoxes & solstices.

### Statement of Purpose

*The Stone* is designed to be a vehicle of communication between members. To fulfill this goal I will have to hear from you! Please send your articles and letters to the address listed below. I keep hearing rumors that people have been looking forward to a newsletter, so take advantage of it! Your comments and opinions do matter. We really want to hear from you. Deadline for submissions for the Winter issue is October 15th. As this is a forum, the views expressed in *The Stone*, including my own, are not necessarily those of LPN-USA.

## TRICKS FOR THE LAB

by *Jacques Trielli*

In laboratory work, we are often led to rectify alcohol during vacuum distillation.

Under atmospheric pressure, we know that the boiling temperature of alcohol is 78°C (172.4°F). As soon as the thermometer indicates 81° or 82°C (177.8° or 179.6°F), we stop distillation in order not to provoke too much steam.

During vacuum distillation, it is not always obvious, unless we have the enclosed chart at our disposal. So, for a given pressure, for example half the atmospheric pressure we have:

Pressure in cm of mercury: 38 cm

Absolute pressure: +0.5 bar

Relative pressure: -0.5 bar

Boiling temperature for alcohol (curve 2): 61°C (141.8°F)

Water boiling temperature (curve 1): 82°C (179.6°F)

The absolute and relative pressure depends upon the manometer we are working with and then upon its gradation. For this reason we gave both values.

*The Stone*, Vol. 1, No. 1, Fall 1990. Editor: Kenneth Miller; Taskmaster and gentle (too gentle?) Nudger: Kevin Townley; Inspiration: Bill Van Doren. Copyright 1990.



# WHAT IS LPN-USA?

by Bill Van Doren

As this is the first issue of *The Stone*, I feel it is appropriate to provide some information on why LPN USA has come into existence as well as its purpose and goals.

Actually, the story began in the early 1940's when AMORC in San Jose, California was offering classes in Alchemy. Albert Riedel (later to become known as Frater Albertus) was one of those attending the classes. In the mid 1940's AMORC stopped holding the classes; however, Mr. Riedel continued studying Alchemy on his own. Over the next ten years or so he worked in his own lab and occasionally traveled to Europe to meet and work with others knowledgeable in the Hermetic Arts. It was during this period that he reportedly received initiation and subsequently decided to teach to others what he had learned. Thus, in the late 1950's he began teaching Alchemy and related subjects, at first informally and then openly under the name of Paracelsus Research Society (PRS). In 1960, PRS began publishing the "Alchemical Laboratory Bulletins" on a quarterly basis (later changed to "Parachemy" and finally "Essentia"). From then on until his illness and death in July 1984, Mr. Riedel (Frater Albertus), with the support of his wife, Emmy Riedel (Soror Emmy), taught those who wished to attend classes what they knew of Alchemy. Classes were held on a regular basis in the United States, Europe and intermittently in Australia and India. In all, approximately 1,500 people worldwide attended the classes

held during these years. While PRS was functioning, the needs of those who were drawn to Spagyrics/Alchemy were largely met. However, once PRS ceased to function, the lack of a school of Alchemy was soon felt. In 1984, a former PRS student, Scott Wilber, set up a laboratory in Boulder, Colorado dedicated to doing research on medicines and solvents produced in the Spagyric/Alchemical way. The individuals hired to work in the lab were also ex-PRS students, so all had, essentially, the same theoretical framework to work from.

In mid 1985, it was learned from Hans Nintzel, also a former PRS student, that a school in France, Les Philosophes De La Nature, was providing lessons and workshops in Spagyrics/Alchemy and Qabala. (Hans came across LPN while he was in France on an "Alchemical Pilgrimage".) Correspondence with LPN began to take place. After translating a number of these lessons, it became apparent that they were what was needed to fill the void left when PRS ceased to operate. As a result, five former PRS students in the Denver/Boulder area got together and requested the right to translate and distribute the lessons.

Subsequently, an agreement was reached with LPN-France to have the lessons translated into English and then, to make them available to interested individuals in English speaking countries around the world.

Interestingly enough, the LPN lessons on Spagyrics and Alchemy utilize the same paradigm as the PRS teachings. However, the LPN material is more detailed and goes deeper into a number of important areas. I attended classes at PRS for seven consecutive years and when I read the LPN lessons, I felt right at home but also was pleased to find a

great many areas filled in to give a more complete picture in both theory and practice than I had before. Furthermore, the Qabala as taught at PRS was an outline only while LPN offers a rather comprehensive six-year course. The focus and depth of information on the Qabala is due to the fact that the President of LPN-France, Jean Dubuis, has studied Qabala intensely for thirty plus years. He has compressed his learning and that of others into this course. The Alchemy and Qabala courses are written so as to complement each other and it is hoped that for a few at least, diligent study and practice will result in Initiation. With Initiation comes the possibility of truly significant progress on the Path.

In addition, the course on Fundamentals of Esoterics was made available in 1988. It was created to provide students of LPN with a world view comprehensive enough to enable them to make practical use of the Alchemy and Qabala lessons and to guide the diligent to the doorway leading to Initiation.

The purpose of LPN-USA is to provide the information and structure through which the highest level available of information and teachings on Alchemy, Qabala and related subjects can be obtained. As the membership grows and the organization builds a stable financial base, then funds will be used to translate key manuscripts and books as yet unavailable in English which will further advance our understanding. A permanent LPN-USA laboratory and subsequently workshops will also be added sometime in 1990.

The present goal of LPN-USA

# UNIVERSALITY OF ALCHEMY

by G. Rainsart

## A look into Indian Alchemy

NAGARJUNA said: "Transmutation can occur through drugs or through yoga."

The Alchemist strives to attain the same result as the yogi by projecting his self-discipline on matter.

Because, since a perfect solidarity between physical matter and the psychosomatic body of man exists (both are a product of the primordial substance of Prakriti), the projected self-discipline on matter is equivalent to an internalization of the operations which are accomplished in the laboratory.

—Nature (Prakriti), the prisoner of time, is liberated by the work of the alchemist. Liberation-Redemption.

—In the "Samkhya-Yoga", it is said that any spirit (Purusha) that conquered its autonomy, liberates at the same time a fragment of Prakriti for it allows the matter which constitutes his body, his biology and his psychomental life to reabsorb and reintegrate the primordial mode of Nature that is absolute rest.

The substances that are used are "various moments" of the inexhaustible manifestation of Nature. By working on them actively, the Alchemist touches the "Prakriti".

—The work must be active for, in exchange, the Nature "Prakriti" creates "particular" moments in the physiological and psychomental life of the Alchemist that progressively lead him to the threshold of deliverance.

Quotes and Interpretation from Mircea Eliade's work *The Forge and the Crucible*, 1962.

## LPN-USA...

(continued from page 2)

is to become a worldwide network of students, mutually supportive and drawn together by our vision held in common. Through our collective efforts will come Initiation for a few and for all a better understanding of the nature of the Absolute, its creations and the purpose and destiny of man in the universal plan.

---

## QUOTE OF THE SEASON

---

*"Alchemy is the art and science of bringing natural things to their inherent perfection by natural means."*

---



---

---

## NOTICE

*The Stone* is published primarily for the benefit of the membership of LPN-USA. We hope to get member's feedback regarding what they would like to see in it. It is an excellent opportunity for members to communicate with each other through personals or to share their experiences and research in relevant studies. Notices will be carried concerning where to find minerals, herbs, labware and other necessary supplies for experiments. If anyone would like to offer items pertinent to the Lessons for sale, that would also be appropriate. Please contact the editor. Articles from members are solicited for submission to the Editor for evaluation

*The Stone* will be included in the cost of Lessons being received for the first two quarterly issues. Next year we will probably have to charge \$20.00 per year for the subscription of four issues. However, members will be notified of this change at the time that decision is made. For non-members wishing to subscribe to *The Stone*, the price will be \$20.00 per year for all issues after Volume 1, No. 1, which is a complimentary introductory issue.

# SPAGYRICS

by Jean Dubuis

Etymologically, the word spagyry in Greek means to separate and unite. However, while this is actually one of the preparation methods in Spagyrics, it is not the only one and does not explain its essential nature.

## Spagyrics and Alchemy

Spagyrics and alchemy are often confused for they share common concepts and methods, but while we may regard spagyrics as a part of alchemy, there is a difference in intention between them as well as a divergence in the method used in practice.

Spagyrics essentially deals with bodily health. It is not an initiatory pursuit, whereas alchemy is the medicine of the "soul" and its true goal is initiatory. Spagyric operations, particularly operations of the vegetable kingdom, do not require a specific state from the operator. The link between work-matter and operator is weak. On the contrary, in

alchemy, the bonding between matter and operator is very strong, and no one can transmute anything if he hasn't transmuted himself first. In alchemy, the psychic quality of the operator is essential.

There is another important difference in the principles guiding the methods used in spagyrics and the ones used in alchemy. Spagyrics, like her daughter homeopathy, does not consider healing to be the result of chemical actions, but considers that energies, for which bodies are the vessels, are responsible for the healing. Homeopathy strives to "activate" the energy by eliminating the vessel. Spagyrics purifies the vessel in order to eliminate the toxic part and then creates in the body a state of resonance that increases the level of energy considerably. Alchemy also purifies matter and its energies but in addition—and this is the

essential difference—it accelerates the evolution of matter.

## ALCHEMICAL AND SPAGYRIC CONCEPTS OF LIFE AND MATTER

The alchemical concept of life and matter lies at the opposite pole of that of the current scientific community. Science is trying to find out how matter created life. Alchemy states that life created matter. Alchemy affirms that, at the origin, there is consciousness. Consciousness is the need to Be of the Absolute. In order to satisfy this need, consciousness created life, and in order to evolve life created matter. This "vital pressure" is omnipresent in the universe and if a situation is created or a product that is favorable to it, it concentrates and brings matter to life in a form suitable to the three kingdoms. The power of this contribution is a function of both the quality of the vessel's "reso-

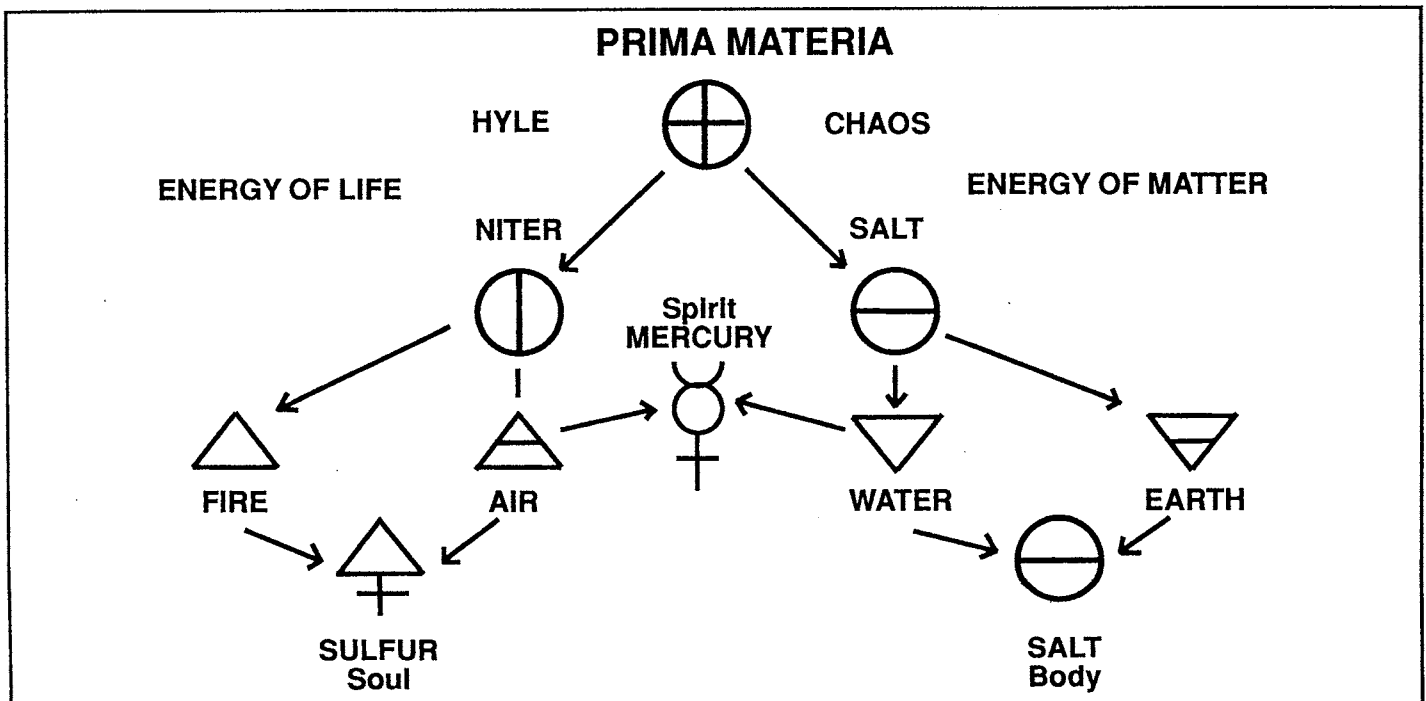

## SPAGYRICS...

(continued from page 4)

nance" and its purity. This vital energy will be used by man for the healing of his body in spagyrics and if, through alchemy, this energy is brought to a higher level, it will heal the subtle bodies of man who will then be initiated in the highest sense of the word.

We need now a brief synthesis of the alchemical concept of natural energies.

Alchemy declares:

1—that everything that exists issued from a unique energy, Chaos, Hyle, the Primordial Waters, etc.

2—that this undivided energy is differentiated into two opposing but symmetrical energies:

— Niter, the active energy which is the energy of the Soul which, in turn, activates the Spirit.

— the Salt, the passive energy, which is the matrix (womb) of matter.

From this point on, the words which are used do not have the common meaning that is given to them nowadays. As a matter of fact, all ancient texts are actually written in code.

### The three Principles, the four Elements

Next, a second division of energy occurs. The Niter is divided into two elements: one active, Fire, the other passive, Air. At that level, Air approximately corresponds to what yogis call Prana. The alchemical elements of Fire and Air are the supports for the energies which animate beings. The combination of Fire and Air yields Sulfur or the Soul of things and in the three king-

doms the supports of Sulfur have a greasy appearance such as an oil, a grease or an oily resin. Curiously, the minerals saturated with alchemical Sulphur retain a greasy appearance after calcinations performed at temperatures higher than 1000°C (1832°F).

Concurrently, Salt divides to give Water (active) and Earth (passive). These two energies are insuring the formation and the determination of matter. When combined, Water and Earth give the Salt of the Earth so called in order to distinguish it from the Salt directly issued for the Chaos and which is, in a way, the Salt of the Sky.

We now have two alchemical principles the Salt and the Sulfur. The third principle is Mercury which results from the combination of Air and Water. This third principle contains therefore an element of the domain of Life—Air—and an element of the domain of matter—Water. Mercury, the messenger of the gods, unites the spiritual and the material, therefore his central role in alchemy and spagyrics.

The alchemical and spagyric healing principle is based on the following principle: the cause of the illness, whether animal, vegetable or, to a lesser degree, mineral comes from the fact that the animating, original energy progressively becomes corrupt and loses its purity and its primitive power through its relation, its incorporation into matter. There are a number of methods to obtain healing products:

1—Return to a body its original animating energy, its purity, its original power.

2—Draw off energy from where it is little or not at all contaminated, i.e. in the mineral kingdom.

3—Attract and capture the animating energy before its incorporation into a body.

## RULES OF THE OPERATIONS

It is impossible to understand the mechanisms of alchemical or spagyric operations if one doesn't know the rules that preside over them.

a) In no event should the elements, bearers of life, be destroyed nor their energies driven away. If the energies are driven away, re-vivifying is essential.

b) In each kingdom, the extraction liquid of the Sulfur is the Mercury of that kingdom. In the vegetable kingdom the Mercury is alcohol. In the mineral, the Mercury obtained through the wet way is a liquid similar to acetone or acetaldehyde.

c) Purified Salt is the purifying element. It is also a magnet for life energies which it attracts and determines according to its nature.

As the word spagyry means to separate and unite the three principles are separate, purify (or revivify) and unite again. The result will be an Elixir or a Stone.

## METHOD OF OPERATION IN VEGETABLE SPAGYRICS

### Preparation of an elixir

By circulating pure alcohol on the dry plant, for instance in a Soxhlet extractor, you separate the plant into two parts, on one side, the tincture, that is to say the Sulfur and the Mercury dissolved in the alcohol and on the other side the feces, which contain both Salt and impurities. Through high temperature calcination, you eliminate the element carbon and, if the calcination is sufficient, the Salt now only contains mineral elements, that is to say that the salt regains its quali-

ties as originally determined.

Then pour the tincture, which contains the energies of life, over the Salt, and circulate the whole mixture. Pure Salt attracts the impurities of the tincture.

This completes the spagyric cycle.

If there were repetition of the cycle separation-calcination-circulation, there would be evolution of matter, and this is where you pass the border between spagyrics and alchemy, because the repetition of a cycle has an evolutionary effect.

According to Eastern (or elsewhere) reincarnation doctrines, this process is similar to the natural process; that is to say that there is a time where the Soul, Spirit and Body are united for a mutual reciprocal work upon each other and a separation phase where the elements are purified separately.

There are other preparation methods. For example, we can attempt to revivify a plant with a "new" vital energy. Pure Salt behaves as a magnet for the vital energy and if it is exposed to air during the spring, it can bring a significant quantity of energy to the product.

The elixirs have two principal modes of action. First, action upon an organ or a deficiency: these are the "particulars", their field of action is selective and these elixirs are essentially spagyric. On the other hand, where there is action on the totality of the body and its deficiencies: these are the "universals" and they require an alchemical preparation.

### The "particulars"

In ancient texts, in order to determine a priori the action of a spagyric preparation, we refer

either to the signature theory or to planetary attributions. In the signature theory, the healing power of a plant is defined according to the bodily organ it resembles.

Besides the various authors' differences in opinion regarding the planetary attributions, we can remark that today, a plant's attributes may differ according to its method of culture.

These attributes can be more easily determined by the following procedure: isolate the organic salts of the plant—what the ancients called the Salt of the Sulfur—and examine the crystalline mineralogical system of the Salt. In this manner, you will discover seven types of Salts which correspond to seven types of crystals. We chose, for convenience, the ancient planetary attribution system and we came up with the following results:

CRYSTAL	PLANETARY ATTRIBUTION OF THE PLANT	BODY
Cubic	Saturn	Body structure, Bones
Tetragonal	Jupiter	Assimilation - Lungs Stomach - Liver
Orthorhombic	Mars	Strength - Blood quality
Monoclinic	Sun	Heart - Circulatory system - Arteries
Triclinic	Venus	Veins - Kidneys - Sex excretions
Rhombohedral	Mercury	Speech - Throat - Organs of Senses
Hexagonal	Moon	Brain - Sex organ

### The "Universals"

Through the repeated work of cohabitations, a new balance of the four elements of Fire, Air, Water, Earth is formed. If the equilibrium is reached, we have the Quintessence. In this case, the range of healing powers is very wide and the origin of the product has a stronger effect on

the power of the action rather than on its nature.

The same phenomenon can be observed at a lower level if one uses, instead of the elixir, spagyric Sulfur alone, provided it is obtained by direct extraction or distillation of the tincture.

The action of the elixirs or Sulfurs of a mineral or metallic origin is more powerful than the action of ones of a vegetable origin.

Products in a decreasing order of strength:

#### Mineral:

gold Sulfur or tincture  
silver Sulfur or tincture.

#### Vegetable:

spagyric elixir  
oak mistletoe  
celandine  
horsetail  
alchemilla.

The advantage of spagyrics is that the method which is used allows us, while keeping and even reinforcing the healing energies, to eliminate the toxic side of the plants or the products used. In addition, the presence of the Salt element produces a stronger action on a physical level.

**FRENCH EDITORIAL**

(from LPN-France newsletter, *Les Petit Philosophe*, #24, 1985)

We stated and we shall repeat that we are a research group and that we do not claim any tradi-

tional affiliation. We do not state that our way is the one and only genuine way. We simply say that the path we propose is correct and that it will lead any person of goodwill who patiently works with his mind and heart, to initia-

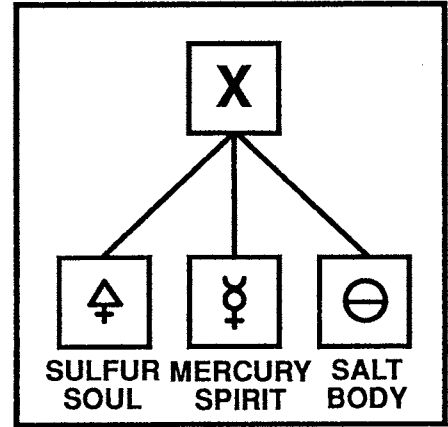

**THE PLANETS AND THE CRYSTAL SYSTEMS**

SATURN  
Cubic

JUPITER  
Tetragonal

MARS  
Orthorhombic

SUN  
Monoclinic

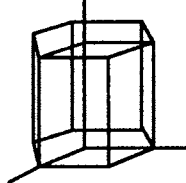
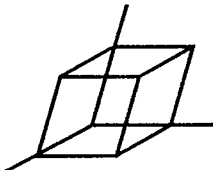
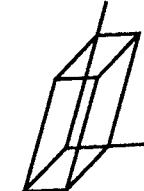
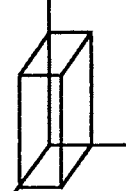
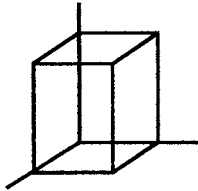
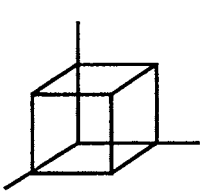

VENUS  
Triclinic

MERCURY  
Rhombohedral

MOON  
Hexagonal

tion.

The Spagyry-Alchemy classes and the Kabala classes, one like the other, have definite results among our members. We know that, to this day, these lessons are neither perfect nor complete, but as the Research Group's projects are progressing, as our experiments along with what is given is proceeding, we update them and distribute them to all active members concerned. Therefore, we believe that our classes, if not



*Raphael Cistodix. sculptit.*

*Stephan Michelspacher*

# 20TH CENTURY MASTERS ON THE PHYSICS OF ALCHEMISTICAL TRANSMUTATION

Edited by: Anthony M. House

"In alchemy, the concept of transmutation is simply identical with every transformation of elements." (Manfred M. Junius)

This statement by Professor Junius says much to anyone interested in the concepts which nuclear research has brought to light in this century. As members of the Philosophers of Nature it should be our goal to penetrate deeply into the polarity of Physical science as well as the Spiritual alchemy in order to demonstrate to ourselves and others the validity of Alchemia in its most broad definition. Therefore, what appears in this article are the statements of alchemists about the importance of modern research in defense of transmutations of elements, bringing clues to the readers, which can lead to an approachable way of understanding what can oftentimes be a very difficult study, viz., physics. On March 23, 1989, two chemists, one from the University of Southampton, England, and the other from the University of Utah, U.S.A., shocked the scientific community with an announcement that they had achieved cold fusion, the papers calling it desk top electrolysis. They astounded physicists and chemists all over the world with their startling announcement. Working together on the details of such an event as room temperature fusion, fifteen years were spent in research, then, using a palladium core immersed in deuterium rich deionized water, and an electrode made of platinum, they confirmed their theory, producing

helium 3 and 4, as well as tritium and neutron output, as a result they got heat output which exceeded the energy put in. Amount of energy used was 6-8 volts! This met the 'bottom line' for fusion energy.

After hearing of the announcement, several laboratories DROPPED what they were doing and took up the experiment. After much hair-pulling and fussing with getting details out of the two chemists, several University Labs in the U.S. and over 12 other countries reported results exceeding the bottom line of physicists. And to top it all off, an asteroid passed within 500,000 miles of the Earth's orbit through space, on the same day as the

announced by Heavenly Messengers, (the last asteroid to pass this close was in 1937, and was dubbed HERMES!, witness the explosion of atomic research). More often than not, these new discoveries are looked upon (by those whose jobs, credentials, and research funding would be in jeopardy if the discovery proves to be true) as another blemish in physicist's hot fusion research. And as usual the cold fusion experiment was quickly covered up!

We shall begin to understand the principles of Alchemical transmutations, by the following statements by several Alchemists of this century:

"Nothing of basic importance has been discovered this century (20th) which does not confirm the fundamental teachings of occultism. Take, for illustration, the theory of the electrical nature of matter and the method of its grouping. It well deserved a Nobel Prize, for it was a physical demonstration of the old alchemical doctrine, "As in the macrocosm, so in the microcosm". Or, "As above, so below."

"Sir Ernest Rutherford bombarded nitrogen gas with alpha rays of radium and produced helium. This is transmutation of matter—done differently by the ancient alchemists, but, nevertheless, done. So, too, Dr. Adolph Meithe, followed by Dr. Kurlbaum, passed electricity through mercurial vapor and changed a part of it into gold. Professor Nagaoka, of Japan, did the same thing. In the same year,

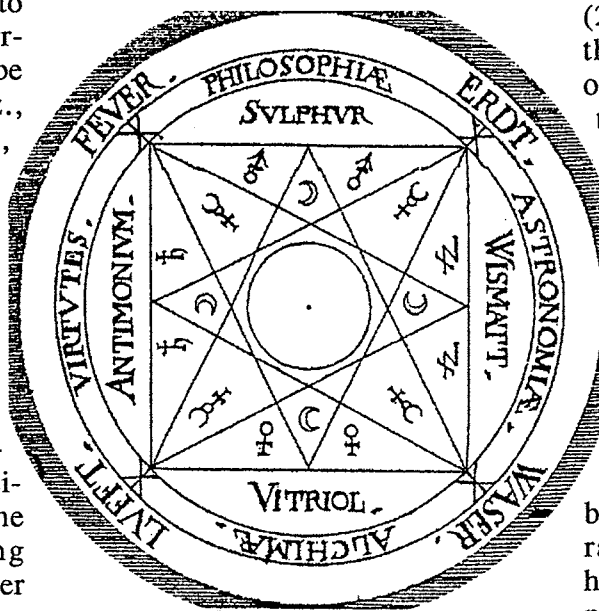

announcement! Being discovered 11 days AFTER it passed, it was photographed by accident by an astronomer from NASA and called simply 1989FC.

As always, NEW discoveries, or perhaps, RE-discoveries, are



## 20TH CENTURY MASTERS...

*(continued from page 8)*

Arthur Smits and A. Karsen, of Amsterdam, decomposed lead and turned part of it into gold. Is this not modern alchemy? Why should any modern man, scientist or skeptic, presume to say the ancient alchemists did not have the knowledge they claimed? Is there but one way—the electrical—to transmute metals? Paracelsus in his books on alchemy, shows seven different ways to produce the result for gold alone.” (Richard Ingalese)

“Knowledge and know-how are ever the new poles of polarity in the unfolding consciousness of man. They emerge out of the innermost atom of an indestructible faith in God and a sensing of the existence of a Divine Being. Being is eternal strength and eternal adding upon. Being is eternally descending and ascending, the eternal change of life and death, but in such a manner that even that which we call death and decay is in the fullest sense of the word a transformation, or rather, a regrouping of matter as a tangible expression in an imponderable, intangible field of force. Innumerable are the forces that are in essence only the expression of but one force. The initiate knows of the existence of this energy—the Secret Trinity—be it in sunshine or moonlight, be it in the waters of the earth or heavens—be it in the joyously creative womb of Mother Earth, or in the dry, moist, cold, or the warm breath of the wind. To know about these means to be able to have powers that serve us and follow the outlined paths of creation.” (Volpierre)

“Meanwhile enormous forces

have to be utilized by modern physicists, examples being particle accelerators, cyclotrons, etc. The alchemists in comparison use very simple, almost crude, methods to achieve their ends. It is conceded that physical science has accomplished things which the alchemist did not achieve, but at the same time it too must be admitted that the alchemists accomplished things which science has not been able to achieve, foremost among them the Philosophers Stone. The Philosophical Mercury, the very substance required to produce the Philosophers Stone, is also an enigma to today's science. The question therefore: What is the Philosophers Stone?, is impossible for science to answer, because it cannot produce it. We have no alternative then, but to look to the alchemists for the answer. Their reply is: The Philosophers Stone consists entirely of substances derived from the metallic realm, wherein the greatest potency is to be found that enables a transmutation of one element into another. The enormous force necessary to release the energy to accomplish this transmutation is, by analogy, to be found in the freeing of the atom as demonstrated by atomic fission and fusion, which are also found in the metals, such as uranium etc.”

“Nowadays, metal transformations are no longer events that cause a stir. When, about the turn of the century, the word transmutation was mentioned in physics, it only called forth contempt. Today, conversely, it is a familiar word in science. Artificially manufactured elements, such as plutonium and neptunium, have become a matter of course. Metal transmutation, that is, physical Alchemy, does not encounter too many obstacles today. Modern

times have therefore vindicated alchemists in this domain. Whoever is interested in gathering further evidence need only follow scientific literature.” (Albertus)

“Many physicists insist that transmutations are only possible with enormous expenditures of energy, but that they then occur at very high speed. Perhaps what has been overlooked is: Why should it not be possible to achieve transmutations with lower energies but with greater loss of time? Question: How can the corresponding energies be measured, when they are not even known? Physical science now knows that physical transmutation is no fancy of deluded minds, but fact, proven and demonstrated. The discipline of nuclear chemistry demonstrates that a radioactive element is constantly transmuting. The atoms give off particles whereby the number of protons changes and a new element is formed, for example lead. Physicists distinguish between three kinds of nuclear changes—fission, fusion, and transmutation. In fission (splitting), the nucleus splits into two nuclei; in fusion (joined together), two or several nuclei combine into a heavier nucleus. Here the Hermetic axiom, *Solve et Coagula, et habebis magisterium*, applies meaning; Dissolve and bind, and you will have the magistry. In the course of the transmutation (transformation), a radioactive element disintegrates through the regular emission of particles. Every element can be made radioactive by bombarding it with alpha particles or neutrons. In this way the element changes into a radioactive isotope.” (Junius)

“In fact it can even be said somewhat hesitantly, that all existing named and unnamed ele-



## 20TH CENTURY MASTERS...

(continued from page 9)

ments in reality represent isotopes mixed out of seven substances," says another modern day alchemist of this century. (Arya Manas)

These seven substances are the different electron frequencies emitted by each of the original seven planetary bands, symbolically attributed by analogy to the seven metals: gold, silver, iron, copper, mercury, tin, lead. As the outflow of the electronic vortices form each element, six frequencies stabilize into the seventh or shell of coagulated matter. As in octave behavior the flow begins anew and repeats its cycle of creation upon another scale, thereby creating further elements.

"Staying with our already somewhat old fashioned proton-neutron-electron model, we find protons have a positive charge, electrons a negative, and neutrons are neutral. If an atom has more neutrons in its nucleus than protons, its atomic weight is higher. Such an atom is called an "isotope". Isotopes are atoms of an identical chemical but of a higher atomic weight owing to the presence of the neutrons. In this way for example, exist the heavier hydrogens.

A. Hydrogen—atomic weight= 1.008; one proton and one electron.

B. Deuterium—atomic weight= 2.016; has one neutron in addition.

C. Tritium—atomic weight= 3.024; has two neutrons in addition, etc.

"In this example the upper number, called the mass number, indicates the sum of the number

of protons and neutrons (if those are present), while the lower represents the number of electrons. The biological transformation of sodium into potassium: where the nucleus of the sodium isotope with 11 protons and 12 neutrons fuses with the oxygen nucleus, which consists of 8 protons and 8 neutrons, (12 + 8), around which 19 electrons (11 + 8), revolve, which is a potassium isotope. That this kind of transmutation about which many physicists are still skeptical, represents a certain heat regulation of the organism seems also to be confirmed by other observations. In tropical climates, the potassium content in human urine rises considerably in proportion to the sodium content, especially in the course of physical work. This says much when we consider that this heat regulation is the very source of long life according to the alchemist."

"Returning to our nuclearchemical model; when a metal has spent itself radioactive metals are produced." (Junius)

"In alchemy, one can add life back into metals (lead) for instance, or take life out of it and so on. Where lead is produced mercury and sulphur getting to it transform it into other metals—gold etc., and it thus becomes transforming in action. Uranium could be reduced to its salts d,

Generally copper, silver, and mercury are the normal subjects of transmutation." (Albertus)

Copper and silver are on the same periodic level as gold. Mercury is next to gold. Zinc is next to copper. Antimony becomes level five. Radium is on periodic chart below mercury 80, being 88 group 2, lead 82 group 4 on the level of gold and mercury. With thallium in between.

"In classical alchemistic texts, we find the word 'projection'. The transformation of a substance is done according to an alchemical method by throwing upon it — that is 'projecting' — a specific active principle. In this sense the bombardment of matter with accelerated particles that cause a transmutation can also be called a modern form of projection. Since the transmuted matter changes color, classical alchemy also speaks of 'tingeing'." (Manfred Junius)

In alchemy, fixed powders that tinge (or color) are considered stones, i.e., projectable active matter. Thus, the Philosophers Stone or transmuting powder of projection of the infamous middle ages. According to Arya Manas, the Stone was a gemstone of crystalline beauty in the days of the thrice great Hermes Trismegistus, and not a powder of saffron color as related by the later alchemist, Van Helmont.

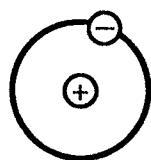

Hydrogen

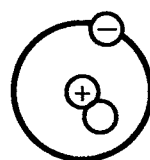

Deuterium

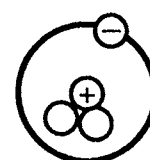

Tritium

(p. 14, *Practical Hdbk of Plant Alchemy* by Junius)

then by removing the electron from the outer shell of mercury it will stabilize by emitting a proton—thus converting to gold.

Today, within this century, there is said to be those who can skillfully produce this high degree of

(continued on page 11)

# SPIRITUS ACETI OLEOSUS

by Gerard Broujean

This article is written for those who have done lesson 35 of the metallic class and who wish to experiment with what Christian Becker calls the SPIRITUS ACETI OLEOSUS.

In chapter VII of his book "L'Acetone ou l'esprit de vin secret des Adeptes" (Acetone or the secret wine spirit of the adepts), Becker gives us his medical observations concerning the cures which numerous of his patients underwent.

Obtained from a soda acetate that didn't present philosophic characteristic, it is obvious that the SPIRITUS ACETI OLEOSUS won't present it either. The SPIRITUS ACETI OLEOSUS enters into the category of remedies qualified as "iatrochemical" by Alexander von Bernus. In addition, the Baron von Bernus had a great admiration for Becker's work and quotes large passages of "Das Aceton" in his book "Alchimie et Medicine" (Alchemy and Medicine).

## PREPARATION

Crush some soda bicarbonate that you place in a big glass funnel, stopped by a cotton pad. Place on top a piece of filter paper; place the side of the paper against the funnel sides.

Pour distilled water, by thin trickles, to wash the powdered salt.

Let it dry and calcinate it in a porcelain crucible. We then obtain a neutral soda carbonate.

Eventually, it seems that a kitchen oven placed on thermostat 10 is particularly good for this calcination (provided the mistress of the house is not watching you). We can thus calcinate a greater quantity of salt than the quantity of the usual enamel kiln; the required temperature for this calcination doesn't need to be high.

As the soda carbonate cools down, dissolve it till refusal in distilled water in order to have a saturated solution that will be

neutralized with acetic acid (trade acetic acid is O.K. although it is better to distill it first). Let evaporate to crystallization and collect very nice crystals in long fine branches. We shall only use (if we want things done well) the crystals of the first crystallization and we shall perform three successive solve/coagula with these crystals.

The soda acetate crystals thus obtained are dried up and put into an incubator for a month at about 45°C (113°F). They will become somewhat dough like. Distillation is performed according to the usual method with acetates.

---

## 20TH CENTURY MASTERS...

(continued from page 10)

crystalline refinement. The rays of such an elevated jewel is reported to transmute man and metals a step in perfection towards its own state of pristine energy with each successive exposure.

"The crystal represents the 'individuum' in the mineral kingdom and accordingly belongs to its law of evolution. But this should not be understood that each mineral has only one form of crystallization and those different forms of crystallization represent sort of a ladder. No! The same mineral can also, according to the laws under which the crystallization takes place, develop to various heights, either naturally or artificially." (Arya Manas)

END OF PART ONE, TO BE CONTINUED IN THE NEXT ISSUE. {Editor's note: Please send in material, letters, questions, for the next issue. Send to Kenneth Miller, 405 West Washington St. #314, San Diego, CA. 92103. See you next time!}

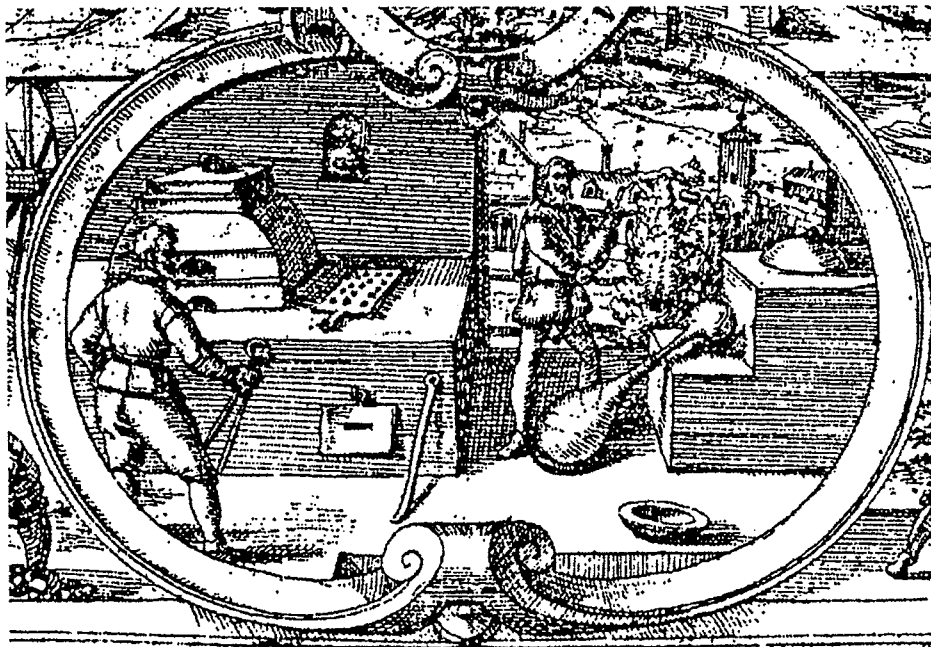

# THE SUN, MOON AND PLANETS IN THE CONSTELLATIONS

[from March 22, 1991 through August 22, 1991 at 0:00 hr (midnight) Greenwich Mean Time]

## SOLAR

Mar. 22, 1991	00°52'♈	June 22, 1991	00°06'♎
Apr. 22, 1991	01°23'♈	July 22, 1991	28°43'♎
May 22, 1991	00°26'♈	Aug. 22, 1991	28°26'♎

## PLANETS

	♃	♄	♅	♆	♇	♁	♂	♆	♃
Mar. 22, 1991	18°00'♈	03°45'♈	23°46'♈	03°40'♎	04°24'♎	13°30'♎	16°33'♎	20°10'♎	24°54'♎
Apr. 22, 1991	19°39'♈	10°31'♈	10°18'♎	04°20'♎	06°20'♎	13°49'♎	16°46'♎	19°30'♎	23°15'♎
May 22, 1991	06°29'♈	14°15'♎	27°22'♎	07°31'♎	06°49'♎	13°22'♎	16°29'♎	18°40'♎	21°40'♎
June 22, 1991	05°59'♎	15°13'♎	15°42'♎	12°38'♎	05°51'♎	12°19'♎	15°49'♎	17°56'♎	19°04'♎
July 22, 1991	25°31'♎	05°22'♎	03°59'♎	18°41'♎	03°53'♎	11°08'♎	15°00'♎	17°35'♎	18°56'♎
Aug. 22, 1991	28°11'♎	29°46'♎	23°26'♎	25°24'♎	01°41'♎	10°10'♎	14°19'♎	17°44'♎	18°29'♎

## LUNAR PHASES

	MAR			APR			MAY			JUN			JUL			AUG		
	DY	HR	MN	DY	HR	MN	DY	HR	MN	DY	HR	MN	DY	HR	MN	DY	HR	MN
New Moon	16	08	10	14	19	38	14	04	36	12	12	06	11	19	06	10	02	28
First Quarter	23	06	03	21	12	39	20	19	46	19	04	19	18	15	11	17	05	01
Full Moon	30	07	17	28	20	59	28	11	37	27	02	58	26	18	24	25	09	07
Third Quarter	08	10	32	07	06	45	07	00	46	05	15	30	05	02	50	03	11	25

## MOON AT 0:00 HR. (MIDNIGHT) (Mar. 21 through Aug. 21, 1991)

03/21	00°14'♈	05/06	03°33'♎	06/20	08°09'♎	08/05	01°49'♈
03/24	12°39'♎	05/09	10°31'♈	06/22	03°28'♎	08/07	00°45'♎
03/26	10°37'♎	05/11	07°02'♈	06/25	09°50'♈	08/09	00°32'♎
03/28	08°10'♎	05/13	05°22'♈	06/27	03°32'♎	08/11	00°15'♎
03/30	05°05'♎	05/15	04°58'♈	06/30	09°01'♎	08/14	12°38'♎
04/01	01°03'♎	05/17	04°48'♎	07/02	03°08'♈	08/16	08°46'♎
04/04	08°03'♈	05/19	03°52'♎	07/05	11°03'♈	08/18	03°26'♈
04/06	01°48'♎	05/21	01°42'♎	07/07	08°09'♈	08/21	09°03'♎
04/09	07°34'♎	05/24	11°13'♎	07/09	06°55'♈		
04/11	02°30'♈	05/26	06°23'♎	07/11	06°55'♎		
04/14	12°47'♈	05/28	00°50'♈	07/13	07°09'♎		
04/16	11°23'♈	05/31	06°33'♎	07/15	06°29'♎		
04/18	10°31'♈	06/02	00°09'♎	07/17	04°10'♎		
04/20	09°23'♎	06/05	06°23'♈	07/19	00°10'♎		
04/22	07°29'♎	06/07	01°58'♈	07/22	06°51'♈		
04/24	04°47'♎	06/10	13°38'♈	07/24	00°32'♎		
04/26	01°18'♎	06/12	13°24'♈	07/27	06°03'♎		
04/29	09°39'♎	06/14	13°42'♎	07/29	00°13'♈		
05/01	04°11'♈	06/16	13°20'♎	08/01	07°48'♈		
05/04	09°53'♎	06/18	11°32'♎	08/03	04°11'♈		

NOTE: These tables are calculated and published for the purpose of determining optimum planetary configurations for particular alchemical operations.

## IN THIS ISSUE

- COMPLEMENTARITY AND ALCHEMY** .....1  
*P.R. Churcher*  
 Some thoughts on scientific alchemy.
- PRIMUM ENS MELISSAE** .....2  
*Greg Boag*  
 A preparation described by Franz Hartmann from Paracelsus.
- EXPLORING SIN AND KARMA** .....5  
*Jean Debuis*  
 Taking personal responsibility for our own evolution.
- 1990—A VISIT WITH JEAN DEBUIIS IN MALASHERBES**.....5  
*Bill Van Doren*  
 An alchemical pilgrimage to visit the founder of LPN in France.
- AN ALCHEMICAL SEMINAR WITH DR. MANFRED JUNIUS** .....7  
*Hans W. Nintzel*  
 A successful alchemical symposium last July in Dallas, Texas.
- SPAGYRICS—MONTH 1** .....8  
*Paul W. Baines*  
 More about Melissa from a student who has actually done the LPN Spagyric Lessons!
- 20TH CENTURY MASTERS** .....9  
*Anthony House*  
 A continuation of House's article from Vol. 1, No. 1 concerning the alchemical transmutation.
- ALCHEMY WORKSHOP WITH DR. WERNER NAWROCKI** .....11  
*Bill Van Doren*  
 An Alchemical Workshop in Santa Monica, California in early February
- ASTROLOGICAL TABLES** .....12  
 The Sun, Moon and planets in the signs from March 22 through August 21, 1991.

Send in your submissions (photographs, drawings, charts and graphs are encouraged), advertising, ideas and comments to Kenneth Miller, 405 West Washington St. #314, San Diego, CA 92103. Remember, all dues and questions about your membership should be addressed to LPN-USA, P.O.B. 11218, Boulder, CO 80301.

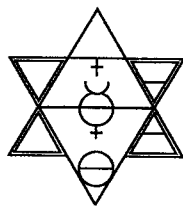
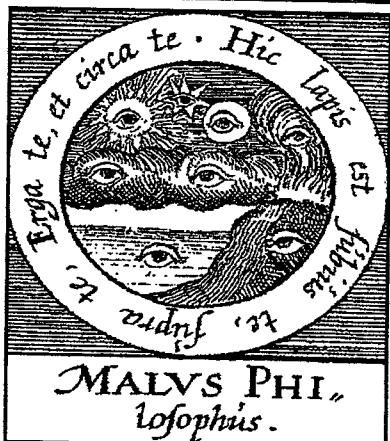

# The Stone

Vol. 1, No. 2 & 3

Winter-Spring 1990-1991

## WELCOME AGAIN TO THE STONE

Welcome to our second issue, which, because it is quite late, has become the Winter-Spring issue. This issue has more articles and something for just about everyone, but we need more! If you would like to write or submit something please do so.

In an effort to create broader networking, we would like members who are interested in corresponding with each other to submit their addresses and/or phone numbers along with a short (50 words or less) description of what you are doing and what your interests are. These will then be published in a special section in the next newsletter.

## COMPLEMENTARITY AND ALCHEMY

by P. R. Churcher

My research interest is the philosophy of Complementarity which was created by Niels Bohr, the physicist, in the 1920s to explain why light and other atomic phenomena showed themselves in some experiments to be waves and in others to be particles. Bohr concluded that light should be represented as both waves and particles, as these were complementary pictures. This situation arises due to the fact that all we can know about reality comes from experiments, whether these are physical, such as in micro-physics, or intellectual, such as "individualism" or "collectivism" in sociology.

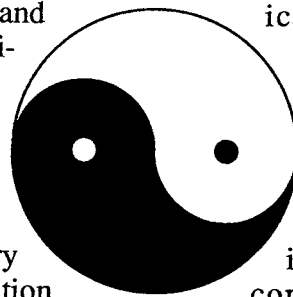

The conclusion, after 5 years of study, is that we are cognitively limited to understanding reality in two simple ways, which produce complementary explanations. These are subject-object (e.g., mind/brain) and micro-macro (e.g., micro-physical and macro-physical). This relates to Alchemy in a number of ways:

1) Experiential accounts of reality (for example, feelings and experience of the matter in the retort) need only correspond in some way with objective reality; in other words, they are not going to be or need not be the same.

2) At the level of the unconscious or subconscious, where the cognitive limitations which produce complementarity do not

(continued on page 4)

*The Stone*, Vol. 1, No. 2 & 3, Winter-Spring 1990-91. Editor: Kenneth Miller; Taskmaster and Gentleman Nudger: Kevin Townley; Inspiration: Bill Van Doren. Copyright 1991.

# PRIMUM ENS MELISSAE

by Greg Boag

There are many hundreds, if not thousands, of relatively simple experiments that the apprentice can turn his hand to in order to increase his health and understanding.

While searching my library for just such an experiment which would fill in time while waiting for other work to mature, I came across a tract which spoke of a preparation called the Primum Ens Melissae, explaining its wonderful properties, but not giving a hint of its preparation. I asked around concerning any record of practice work on this but unearthed only literary gossip and no sign of any real experience. Then I eventually came across a small book by Franz Hartmann called *Paracelsus the Greatest Alchemist* (1910), which contained a basic recipe for the extraction of the Primum Ens Melissae.

The recipe given in Hartmann's book had a few misleading or, rather, incorrect points, as experience eventually proved. The process which I give below is corrected and expanded from the original, yet only gives that which is necessary for your own experimentation, as space excludes me from including more.

It is my opinion that any student having completed the first year of the Philosophers of Nature Spagyric course has all the necessary information, if not experience, to successfully complete this work and expand his knowledge considerably concerning the Creative process. All the matters involved in this work are products of the vegetable kingdom, but the final result, the



Primum Ens proper, contains some elements which by rights are extracted from the mineral kingdom.

I believe anyone who succeeds in this work will be well rewarded for their effort, as the Primum Ens, once extracted by the following process, is surely one of the noblest preparations taken from the vegetable realm.

The Ens of anything is its Prima Materia, a constituting and invisible, intangible, spiritual substance, which by art may be captured in a suitable vehicle and brought into manifestation. Paracelsus, in his *Volumen Medicinae Paramirum* (c. 1520), when speaking of the various "Entia" (plural for Ens), tells us that these Entia are the active principles or influences which govern (our) bodies.

The Primum Ens of Melissa Officinalis (Lemon Balm) is a spiritual substance whose prime influence is said to be that of the Sun vibration, and, secondarily, that of Jupiter.

## The Extraction of the Primum Ens Melissae

### The First Menstrua:

1) The first operation, the production of the first of the two menstrua involved, must be accomplished during the first waxing phase of the Moon, as the Sun enters Scorpio (Taurus in the northern hemisphere).

Take 300 gms of potassium carbonate, (prepared well in advance), preferably in the form of snow-white, calcined argol or wine stone, which is the calcification that collects on the sides of old wine barrels or modern stainless steel wine vats. It is possible to use anhydrous potassium carbonate ( $K_2CO_3$ ) from a chemical supply warehouse, but it isn't as lively as argol.

Wrap the potassium in a porous cloth and during the night hang it in a damp atmosphere free from discordant odors and vibrations where the rays of the Moon can fall upon it. Below the bag of potassium position a bowl or jar so as to catch any drips of moisture which will drop from the bag. The salts, being hygroscopic, will attract the atmospheric moisture, generally called Angel water, which is charged with Niter.

An alternative method is to lightly sprinkle a thin layer of potassium carbonate on a sheet of glass, and pour off the absorbed moisture in the morning, adding more potassium as needed.

When the entire 300 gms has dissolved, seal this Angel water in an air tight jar and store it in a cool, dark place. This is your first menstrua.

(continued on page 4)

# PRIMUM ENS MELISSAE

(continued from page 2)

## The Second Menstrua

2) During the next two weeks of the waning Moon, the second Menstrua, which consists of at least 99% pure alcohol, can be prepared by distillation and potassium separation (rather than vacuum distillation) as explained in Philosophers of Nature, Spagyrics Lesson No. 29, pg. 2-4. This pure spirit must be put in a well-sealed jar and kept in a cool, dark place.

## Extraction

3) Now you must wait until the Moon begins to wax again and for the Sun to enter Sagittarius or Gemini in the northern hemisphere. As soon as the time is right on the last Sunday at dawn before the full Moon, half a pound of fresh Melissa tips are to be gathered, then put in the shade to dry until totally devoid of moisture.

4) As soon as the Moon begins to wane again these dried leaves are immersed in the potassium/Angel water menstrua until the liquid covers the herb with a finger's width to spare, then left to macerate in a warm place at the first degree of heat for 24 hours.

Next filter the leaves from the liquid and throw the former away. The liquid will have taken on a deep brown tincture, the sulphur of Melissa, from which you can now extract the Primum Ens.

5) Once the Moon begins to wax again the pure spirit which was prepared before and is now carefully poured on top of the first Menstrua/sulphur mixture to about 1 or 2 inches in depth. You will notice that the spirit floats on top of the first menstrua. Now the Ens Extractor can be put back into a first degree warmth

for at least 2 or 3 days during which time you will see the spirit become lightly tintured with the Ens.

It seems that the relationship between the pure spirit and the Ens is such that any given quantity of spirit will only attract a certain amount of Ens. This being so, it doesn't seem possible to extract a very dark tincture, thus speeding up the total extraction of the sulphur from the lower menstrua.

6) Finally the spirit/Ens is siphoned or piped off of the lower menstrua, being careful not to mix the upper and lower liquids. Store the latter for further use. Then in a water bath at the lowest possible temperature, 85% of the spirit can be distilled off the Ens and be reused.

If the last 15%, after cooling, shows any sign of blotches or dark resinous matter, the concentrated Ens must be carefully decanted or siphoned from its flask so as to leave these impurities behind.

Caution: failure to separate any impurities will cause extreme dehydration upon consumption

These impurities are salts of potassium carbonate and unprocessed sulphur which have become mixed with the spirit because of one or both of two things. Either your Angel water/potassium menstrua is not totally saturated, in which case a small amount of raw potassium carbonate can be added to the menstrua to regain total saturation; or your spirit is not pure enough, in which case you will have to work on it again.

7) At this point, more pure spirit is poured back onto the

lowest menstrua and the extraction process is repeated again (Steps 5-7), until all the color has been extracted from the lower menstrua.

The remaining 15% portions of Ens/Spirit (Step 6, paragraph 2) are added together and regularly reduced by distillation in water bath until a sticky resinous matter is obtained. This is the Pure Primum Ens Melissae

## Dosage

Of course the diluted portions may be taken as they are with amazing results, at no more than (for the first week or two at least) 2-3 drops in white wine in the morning upon rising.

A slight discomfort in various organs may be felt for the first week or so as the Ens takes effect and your system gets cleaned out, depending on the amount of waste particles your body is retaining.

The rejuvenative effects that the Ens will produce, which outer signs are loss of fingernails, hair and teeth (which grow back), will generally only come to effect the pure concentrated Ens.

Send any correspondence to:

Greg Boag  
Box 7210  
Taradale, New Zealand.



## COMPLEMENTARITY AND ALCHEMY

(continued from page 1)

apply, subject and object (as experience) disappear and are united in some unknown form.

3) For every reductive explanation of a phenomenon, e.g., chemistry or physics, there is a holistic level of explanation which science cannot comment upon as experimental interaction when that level produces a phenomenon which is in part the product of the experiment and therefore ceases to be the holistic phenomenon it once was.

4) Religious and occult (see Baillie, 1963, and Grinnell, 1986) explanations of reality are complementary to scientific ones. Alchemy talks in terms of evolution and it has been said that religion has the purpose but not the means, whilst science has the means but not the purpose. There is obviously a need to fuse these approaches.

5) Although all micro-physical phenomena (perhaps particle and wave complementarity above) are not found in macro-physics (e.g., the everyday world) it may be that Alchemy is an explication of dual aspects of matter

Science conveniently forgets the lesson of particle and wave complementarity when it comes to dealing with atoms and

molecules, i.e., matter with macroscopic properties (chemicals). Now if particle and wave aspects of reality apply at the macroscopic level, i.e., the matter in the flask, it might be conceivable to manipulate that matter in two different ways. If the matter is treated as particulate (i.e., gross and physical) then traditional chemical reactions are conducted and traditional results expected. However, if the matter in the flask is considered as potentially manipulable in terms of waves of energy (its other aspect), then those energies could be extracted or trapped and reintegrated.

Why, you may ask, do we not see matter as waves but only in its gross physical aspect? I would say it is because we are conducting the wrong experiments with it; we are also cognitively predisposed to interacting with matter in its particulate aspect. That's useful to us as a species.

Why is it that scientists don't employ wave experiments, views or theories of macroscopic matter? Scientists have largely rejected complementarity as the Western mind finds it hard to accept that reality consists of a contradiction (complementarity). The particle picture is preferred,

erroneously, even in microscopic physics because it is simpler, uniform, physical and analytical. It is the holistic mind which grasps complementarity and is naturally drawn to the wave view, which returns us to the Alchemists.

I believe Alchemy is thoroughly scientific and await with interest some scientific results from the group. If anybody has any views on Alchemy and Science Complementarity please let me know. A Scientific Alchemy group would be of value. Anyone interested? Please write to:

P. R. Churcher  
11 Pevensey Rd.  
Southwater, Horsham,  
West Sussex, UK



### REFERENCES

Baillie, H. (1963). "The Sense of the Presence of God," Gifford Lectures 1961-2. Oxford University Press. London, Toronto.

Grinnell, F. (1986). "Complementarity: An Approach to Understanding the Relationship between Science and Religion," *Perspectives in Biology and*

## ORES FOR SALE!!!

**TRIAD LABORATORIES** is selling high-grade, hand picked stibnite from Bolivia which is available in limited quantities. Maximum order is 20 lbs per student. There is also some bright yellow sulphur from Italy.

Antimony Ore: \$3.25 per lb. 1-10 lbs. \$3.00 per lb. 11-20 lbs.

Sulphur Ore: \$6.75 per lb. 1-10 lbs. \$6.00 per lb. 11-20 lbs.

Handling \$1.00

Make checks payable to: **Russel House, Triad Laboratories, Suite 275, 125 W. Front Street, Wheaton, IL 60187. Please allow 21 days for processing.**



# EXPLORING SIN AND KARMA

by Jean Debuis

In the newsletters and in the lessons we strive to detoxify and free the mind. There was indeed a toxification in the world of exoteric religion by the spreading of the notion of sin as there was in the philosophical and esoteric milieu with the false notion of Karma. Both of these elements, by themselves, constitute a kind of heavy psychological cover that restricts the possibility of action for individuals and stalls their evolution.

In the religious sense, sin is an offence or disobedience to God. In fact there is no sin in the cosmic sense of the term. There is only non-respect for the laws that underlie the universe and the resulting consequences. Bacon said: "We can dominate nature only by being subject to its laws."

The Wisdom that enacted these laws permits, in the framework of their application, a zone

where man can exert his free will. Within this zone, man can work to become or not to become. This is where the false notion of Karma started. Karma is Universal Justice and this Universal justice is that each one is the Son of his work. Through the fruit of one's work, one acquires the elements necessary for one's becoming.

In no event is Karma the reflection of an earthly concept of justice; it is the result of forces which sooner or later will constrain us to take the shortest path toward our becoming. To be in accord with the becoming is positive, evolutionary; the reverse is the loss of harmony. Man does not choose his becoming, but rather, he made this choice which he accepted: the path of involution or evolution. His freedom only pertains to the choice of paths that lead to his ultimate realization.

Today our society and consequently all the people forming it are impregnated with these false notions of sin and Karma. The result is an action upon the unconscious and on the conscious of all those who do not make a serious effort to break away from those forces or toward self-liberation.

The awakening of the heart through generosity and love is of major significance because the Sephiroth of the heart, Tiphareth, is the only one that is linked to all other centers. It can therefore transmit all that is necessary, this is why we remain responsible for ourselves. Thus, when we shall present ourselves, at the end of our present life before the mirror of justice we shall not be able to lie to ourselves and we won't be able to excuse our limited advance by invoking the embarrassment that others were responsible.

---

## 1990—A VISIT WITH JEAN DEBUIIS IN MALASHERBES

by Bill Van Doren

LPN-USA was organized in order to translate the lessons of LPN-France into English and make them available to the English speaking people around the world. Jean Debuis is the individual responsible for most of the writing of these lessons and indeed his home in Malasherbes, France is where the offices and lab of the parent organization of LPN-France is located. I travel to meet with Jean every 12 to 18 months in order to keep abreast of the lessons and research produced, since my prior visit, and to seek guidance and advice on the operation of the LPN-USA.

This year three of us made the

trip—Kevin Townley, Brigitte Donvez, and myself. Kevin specializes in issues of Qabalah and I on the Alchemy and business matters. Brigitte does the translating and monitors and guides the more subtle aspects of intercultural communication between the French and English speakers. We stayed with Jean from 9-18 October.

The following is an outline of what we learned during the visit.

### Alchemy

The research goes on. Currently they are working to refine the methods of the production of sophic mercury with martial regulus of antimony. I

did this work several years ago at the Alden Research Laboratory in Boulder, but the Mercury I produced apparently was not "Sophic" because the red powder was not produced nor did the matter in the Philosophical Egg go through the changes in form and color as described in the lectures. As a result of my previous experience with the work I was quite familiar with the process and thus found it very interesting to note the numerous subtle differences in procedure and philosophy demonstrated to us. I look forward to receiving the series of lessons that will ultimately result from this research so the process

(continued on page 6)



## A VISIT WITH JEAN DEBUIIS...

(continued from page 5)

can be carried out once again and compare the results.

In Jean Debuis' mind, LPN-France is more than anything else a research group. As such he has a number of objectives he would like to see accomplished through LPN efforts. It should, however, be pointed out that LPN-France is not a graded system and that there is a very wide range of interests and experience amongst the membership. Probably about 50-70 members are actually directly involved in the research that ultimately gets expressed as lessons. The rest of the membership looks at LPN-France as a correspondence school and source of information and direction in their own personal process via the courses offered. These people are served by the LPN and for the most part do not directly contribute to the creation of lessons or articles. This is mentioned so that it is understood when the LPN is referred to as a research group it is only the members who are involved in the various research projects who would see it that way. In order to acknowledge this difference in intention and interest of members in LPN-USA the core group was created so that people who are interested in furthering the knowledge of any area of course work can be identified. In time, when a permanent LPN-USA lab is created, we will participate in such projects if there are sufficient members interested in doing so.

The long term goals in Alchemy for LPN-France are as follows:

A. Develop an overall theory of Alchemy as practiced in the laboratory. This is envisioned as being analogous to the theoretical corpus of chemistry and physics. In other words, much of what is Alchemy deals with phenomena which lie outside the

boundaries erected around chemistry and physics and so the Alchemical theory and practice will deal with issues and phenomena not considered relevant or possible by materialist science of today.

B. Put the theory into practice. A theory without practical application is perhaps of intellectual interest, but is not what LPN is all about. If the theory is to stand on its own, practical demonstration of predicted and repeatable results will have to be made.

C. It is believed that if such demonstrations are made, then in time there will be practical application. Historically, these areas of application have been in medicine, metallurgy, mining, psychology, philosophy and others.

D. There are areas in which the Qabalah and Alchemy will interface and the results and products from Alchemical practice will be directly enhanced through application of Qabalistic principles. The fruit of this area of research will not manifest for some years.

These are ambitious goals, but given what is presently known, Jean feels they are realistic ones. One of the invariable Alchemical dictums is theory before practice. It is clear that the key to the whole matter is the further development of the theory. It is expected to take two years to accomplish this much. Stay tuned for further announcements.

### Qabalah

We were given a number of Qabalah lessons which had been revised during the past year. They were 5th year lessons so they don't directly affect LPN-USA at present, since we are only now translating the 3rd year Qabalah lessons.

### Fundamentals of Esoterics

I inquired about a 2nd-year

course along this line. Jean said that work has already started on this project. It will be a year or so before its completion.

### Administration

The efficiency of the LPN-France office organization is very impressive. The number of active members hovers in the 900-950 range. The office is staffed with two secretaries who work about 3/4 time. I watched them, with a volunteer, fill over 900 October membership mailings in about 2 hours. It was a humbling experience, I must say. Jean worked for IBM France, so he has a knowledge of what computer tools are available for an efficient office. Given these tools the two secretaries, Nicole and Michelle, have developed an efficient computerized membership record and order fulfillment system.

Jean has of late been gathering around him a small number of people who help in various ways in the operation of the association. There are 2 or 3 fellows who assist in the demonstrations of Alchemical lab procedures. They are continually building and refining portable devices for such demonstrations. One person who was especially helpful to us was Lucille, a research biochemist, who works at a university hospital in Paris. Lucille very kindly picked us up at the airport and later provided us with a place to stay on the last two days of our visit.

One last point I would like to mention is the very gracious French hospitality extended to us during our stay both at Jean's and Lucille's. It is unlike anything which I have experienced in the U.S. and so seems worth commenting on. The seemingly never-ending progression of meals, snacks of wines, cheeses and bread, was something to behold. The French have definitely cultivated a very gracious lifestyle and developed it to a fine art.

# AN ALCHEMICAL SEMINAR WITH DR. JUNIUS

by Hans W. Nintzel

At the end of July, a week-long alchemical symposium was held in Dallas, Texas. The class was conducted by Dr. Manfred Junius of Adelaide, Australia and was sponsored by the writer. Forty-five people attended.

Many attendees had never been in touch with other alchemists, much less in such close communion. The whole scene was somewhat reminiscent of the first night of classes at the now defunct **Paracelsus Research Society**.

The seminar actually started the weekend prior to the first classroom lecture. This was when Dr. Junius arrived, as did some of the students. Dr. Junius was virtually bombarded with a variety of questions. Michael, as he likes to be called, was always gracious and accommodating. He answered all the questions openly and to the best of his ability.

The first class commenced early Monday morning, July 30, 1990.

The classroom meetings concerned some of the theory of the experiments we were to perform and the techniques for doing them. The students also received a good "look" into Indian Ayurveda (traditional East Indian medicine).

In the classroom, Michael demonstrated his *circulata*, which can be easily described as a liquid plant stone. While this is not a totally accurate description, one can get the idea from it. He placed this liquid into a test tube and to this several basil leaves, cut up, were introduced. In minutes, the *circulata* was tinted green and the basil leaves turned white and sank to the bottom. He shook the test tube to aid the pro-

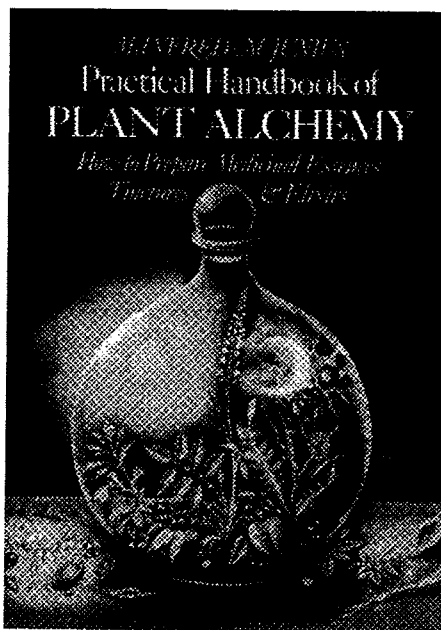

cess and after standing still for a while, the emulsified oil formed a large emerald green "pearl". This was the oil from the basil leaves, the alchemical sulfur. Within this oil, the alchemical salt is to be found.

He set us to making the magistry of Rosemary. This was a separation of the three essentials of the dried plant, including the salt of sulfur, and their recombination. The salts were calcined in an oven to whiteness. The mercury used was SV, the oil being steam distilled, and the philosophical salts being leached out from calcined herbal feces. The cohobation of the spirit on the combined essentials produced an incredible elixir. Its odor was very powerful, delightful and penetrating. We then circulated the elixir for several hours. (Time was in short supply, so many things could not be carried out to conclusion. But we gained insight on how to do it.)

Michael showed a variety of slides depicting various phases of lab and some Indian objets d'art. He showed how closely the Indian system of Ayurveda

matched western alchemy. In some cases, the major difference was in the nomenclature.

About in the middle of the week, we started an operation utilizing what is called in German "Weinstein". Argol, or tartar, is a product scraped from wine barrels and has particular significance in alchemy. We sought medicinal values from the tartar. The crude matter was placed in the flame of a Bunsen burner and a thick white smoke was given off which condensed into a recipient. Intermixed with the liquid condensed from the smoke was the infamous *red stinking oil*. This matter, Michael told us, is carcinogenic. The oil was purified by boiling, then mixing it with a pure vegetable oil (Crisco!), some oil of egg and given to some of the students. The product from tartar including calcined salts, were made into an elixir and all who wished it had some to take with them.

The last major operation was to learn an Ayurvedic alchemical technique which transmutes metallic subjects to organic ones—making "bhasmas". We worked with zinc, melting it and mixing it with buttermilk. After many repetitions we could see the consistency of the matter gradually changing as organic molecules replaced those of the metal.

Michael agreed to return once more if the students were interested. They were indeed. We learned to manipulate glassware and other lab practices. We enjoyed fellowship with brothers and sisters representing twelve states and Canada. We exchanged ideas. Most importantly, we made a lot of new friends.

# SPAGYRICS—MONTH 1

by Paul W. Baines

This project involves working with the herb, *Melissa Officinalis*. Why *Melissa*, as this herb is not considered of great significance in regular botanical medicine in the U.K., being employed as a carminative, anti-spasmodic, diaphoretic and mild sedative? It does not appear to have a place in homeopathy and does not appear in Boericke's *Materia Medica* or the Homeopathic Pharmacopoeia of the United States. A clue may be found in the following passage from Huson's *Mastering Herbalism*.

Llewelyn, a Prince of Wales, was reported to have lived to the age of 108 by reason of the balm tea he drank in the morning and evening. A certain John Hussey of Sydenham also claimed that balm contained the secret of longevity. He drank balm tea with honey every morning for breakfast, and lived to be 116 years old!

The most important clue lies in the words of Paracelsus when writing about the Elixir of Life. He says, "But the vehicle that forms the medium through which life acts consists of elementary substances that are formed in nature, and which form the quintessence of all things. There are some substances in which this quintessence is contained in greater quantities than in others, and from which it may more easily be extracted. Such substances are especially the herb called *Melissa*, and the human blood."

8/3/89

A quantity of commercially dried and comminuted *Melissa* herb was taken and pulverized by hand with a pestle and mortar.

The material was passed through a plastic household sieve until most had been reduced to a coarse/medium coarse power. This operation took several hours. This sort of manual labor is important as it seems that energetic friction and force within the mortar releases some sort of curative force concealed within the crude matter. According to Hahnemann, "Not only the rubbing makes the mixing more perfect but also, and this is most important, there results out of rubbing a surprising change, quite unknown up to this day, in the development of the dynamic forces of the medicinal substance which has been submitted to that elaboration. The medicines are not dead substances as it is supposed to be. Their real essence is dynamic."

The importance of grinding in a mortar is also stressed in the art of making incense, in which instance a chant or mantra may be used whilst grinding the ingredients.

40g of the powdered herb were placed in a small Kilner jar in readiness. Pure, fermentation grade ethanol originating from the EEC wine lake was diluted to 60% with water from the Chalice Well, Glastonbury.

9/3/89

On the first Thursday of the waxing Moon, the alcohol solution was poured on to the *Melissa* shortly after sunrise, being in the planetary hour of Jupiter and having previously energized myself through yoga breathing exercises. Since *Melissa* is attributed to Jupiter, and also the Sun, we chose Thursday for this operation, and

the waxing Moon because we seek an increase in the power of the preparation. The jar was sealed, wrapped in a towel and placed in the airing cupboard. This was left for 14 days, in the dark, without shaking. I suspect that darkness is essential at this stage since, according to Fulcanelli, fecundation and gestation should take place in complete darkness, otherwise the work is spoiled.

22/3/89

Full Moon: Removed macerating *Melissa* and transferred it to a conical percolator fitted with tap and of 1 liter capacity. Liquid was allowed to drain freely into a flask after which the mare was pressed with a cylindrical teak percolator packer. Cotton wool had previously been placed in the bottom of the percolator. Approximately 100 ml of tincture was obtained of a yellow color, not green.

The procedure was repeated as for month one up to the point of calcination. The incinerated material was placed in the electric furnace and calcined at approximately 450°C to burn off the remaining carbon. This took about an hour from reaching the required temperature.

The calcined ashes were placed in the thimble of a Soxhlet extractor and circulated with purified water B.P. which had previously been enlivened by exposure to sunlight under a Bristol Blue glass container (Edwin Babbitt, *Principles of Light and Color*, 1878). This was carried out intermittently for two days. The exhausted ash was removed and stirred up with

(continued on page 9)

## SPAGYRICS...

(continued from page 8)

Aqua Dist. in a beaker and then tested with pH paper. This showed a pH between 7-8, more or less neutral. The contents of the flask showed a pH 11. Thus all the water soluble salts were now contained in the solution in the flask. This solution was evaporated to dryness in a porcelain basin over low heat and the salt calcined overnight in a closed crucible at a temperature not exceeding 450°C.

The contents of the crucible were removed when cool and pulverized in a glass mortar. The salt was redissolved in hot Aqua Dist. and filtered through a fluted paper. A fine, insoluble white powder remained on the filter. This powder was tasteless and dissolved in the dilute HCL without effervescence, possibly calcium hydroxide. The clear solution was again evaporated to dryness and the same cycle of operation reiterated twice more until a pure, white, completely soluble salt was obtained.

The finished product contains a high proportion of potassium carbonate (salt of tartar) which is deliquescent and should be kept in an airtight container.

(To be continued...in next issue)

[Ed. Note: Mr. Baines has done something unique in the history of LPN-USA. He has actually worked the projects given in the lessons in the order taught, beginning with Lesson #1. And he has taken excellent notes of his work and results. He offers them for your consideration.]

## 20TH CENTURY MASTERS ON ALCHEMICAL TRANSMUTATION

(A continuation from Vol. 1, No.1) by Anthony J. House)

All things and beings in the universe contain the three philosophical principles. They are the three necessary substances that make the material condensation possible at all. From the modern viewpoint, we can also call Salt the physical units, Mercury corresponds to undulation, while Sulphur represents quantum of light. Likewise, an acceptable analogy would depict the correspondence between proton (sulphur), electron (mercury), and neutron (salt). In his work **Alchymie und Heilkunst**, Alexander von Bernus designates negative electricity as "prime matter", which, as a chemical body, is atomistically organized. In Indian alchemy, Mercury is also said to be the semen of Siva. Siva, God as the creator, transformer, and destroyer, (so that something new can be created), is the Lord of alchemy, and the cause of every transmutation. The study and practice of alchemy are based on modesty, patience, seriousness, and determination. The

higher alchemical practice can only be transmitted through the personal directions of a qualified teacher. Whoever reads classical texts without a corresponding preparation and compliment, will understand little or nothing. Just like music, the alchemical art cannot be learned solely from books. "Fundamentally, alchemy will always remain an art built on personal initiation." (Junius)

"Gravity is a decidedly long-ranging force acting in space but with correspondingly weaker strength in the subatomic world. This interesting fact was brought to light by Dr. Murray Gell Man, Professor of Theoretical Physics

at the California Institute of Technology. In a lecture delivered at the Institute's 75th Anniversary on October 25, 1966, entitled "The Elementary Particles of Nature," Professor Gell Man stated that, in addition to the forces of gravity and electromagnetism, two other forces, discovered during the twentieth century, are also responsible for subnuclear processes. These weaker interactions cause a particular radioactive decomposition and strong interactions which are considered responsible for connecting atomic nuclei. Further, Gell Man pointed out that if Planck's quantum theory is applied to microscopic

physics, an analogy between the macro- and micro-worlds as a magnificent but confusing discipline results.

Sufficient acknowledgement of the interrelationships of such forces is to be found in these deliberations of an eminent scientist. In general, it is assumed that forces are transmitted by

(continued page 10)



## 20TH CENTURY MASTERS...

(cont. from page 9)

means of quantum particles; for example, the photon quantum of energy acts as a carrier for the forces of gravity, yet to be discovered and to be named, as another scientific exposition of the fact that rays are carriers of forces. All of this implies a definite correlation between the world of the astro-nomers and that of the microphysicists and biologists. These manifesting forces, irrespective of their names, have to be reckoned with in scientific analysis. Scientifically established transmutations of substances such as uranium into plutonium and neptunium imply an intelligent application of the observed behavior of substances. In scientific transmutations, electrons and other charged particles must pass through an electric field of force in order to come into contact with the nucleus. When such forces exert influences which can modify the formation of matter, then, by inference, the law of polarity must also have a similar impact on the material, or the conscious-mental plane. The Sun is the central depository of energy in our solar system. The system, with its orbiting celestial spheres, offers the resistance by which the radiated solar energy is absorbed by them. The planets, including the asteroid belt, are the only celestial bodies of our solar system which offer such essential physical resistance to solar energy, thereby exposing themselves to the spectrum of the Sun. When mass responds in this manner, a similar conscious-mental reaction cannot be ruled out. (Frater Albertus)

"I have therefore something to say to you of Mercury, which the Alchemists in their secret language, tell us is coagulated by its interior sulphur, this operation being the conjunction of their Sun and Moon, or the marriage of

Adam and Eve. Now, this can be understood mystically because they say also that herein is the union of Heaven and Earth, by which you will see that all systems of symbolism, however apparently divergent, meet in the ultimate identity of their one object.

"It is affirmed further that we now behold Mercury as it exists imprisoned in a body, but there will come a day when we shall see it set free from its present limitations and manifested as a pure, fixed, intelligible, constant fire. We know otherwise that the Mercury described by the Philosophers is a fluidic or volatile substance, and that to FIX IT is the Work of Wisdom. These statements are rendered readily intelligible by a mode of interpretation which is peculiar to this grade, for which Mercury signifies THOUGHT.

"It is in fixity, rest, and simplicity that consciousness exceeds the material bounds which encompass it, and receives, according to its measure, the mode of the Universal. There is here set forth a certain great operation of the will which does not

die, the concentration of thought by a high act of intention. Remember the apocalyptic promise to him that overcometh—and the last conquest is that of the logical understanding, so that THOUGHT may be reduced by thought to the point at which it vanishes for a period, but returns subsequently, made more splendid by the transmutation of a great experience. You know that the natural mind of man is earthly above all things, and that the path of our ascent of the Mystic Mountain, must carry us far from earth, far from the ways and forms of the material Mind. You know further that ordinary thought is wandering volatile, and THIS is the Mercury which the Adept is called upon to FIX.

"I have spoken on the authority of the alchemists concerning our imprisoned and liberated Mercury; which are also the FORMS of THOUGHT, one of the errant in the material and confined therein, the other emancipated. The one volatile—the other fixed by Wisdom." (S.L. MacGregor Mathers)

In the discipline of depth psychology, the alchemists who were at the same time students, enthusiastic and active in Pranayama and Tantrick pursuits, either with or without a teacher, learned that: "Sooner or later, most students experience a desire to find an Adept in order to become his pupil or disciple. But no matter how sincere such a desire is, it is futile for the student to attempt to locate a teacher versed in the Grand Arcanum. 'When the pupil is ready, the master will appear.' This ancient precept still holds true. One may search, one may aspire, one may work and study hard until the wee hours of the morning, and yet it will not be evidence that he or she will ever attain that priceless jewel: the Grand Arcanum. For it takes more than a mere study." (Albertus)

(continued on page 11)

### BOOKS! BOOKS!! BOOKS!!!

**J.D. HOLMES BOOKSELLER**

Postal Box 623  
Edmonds, WA. 98020 USA  
Phone/Fax: (206) 771-2701

**FINE BOOKS ON ALCHEMY  
AND THE  
HISTORY OF CHEMISTRY  
16th to 20th Century**

**\*CATALOGUES ISSUED\***

**\*WANT LISTS PONDERED\***

**WE BUY QUALITY BOOKS  
AND COLLECTIONS  
IN OUR INTERESTS**

# Alchemy Workshop on the Seven Hermetic Principles

by Bill Van Doren

Dr. Werner Nawrocki, M.D., from Germany held a 2-day Alchemy workshop, 2-3 February 1991, in Santa Monica California. The workshop was organized by the Santa Cruz Naturopath, Dr. Daniel Beilin.

Dr. Nawrocki maintains an active medical practice in Frankfurt. Since 1974, his clinic has been treating patients with Naturopathy, Homeopathy, Spagyry and Esoteric Psychotherapy, (regression/reincarnation therapy). He also gives lectures and seminars for MDs, Naturopaths, and the public at large. A two-week course in Alchemy has been given in Australia for 3 years and in Europe for 5 years. Dr. Nawrocki's teacher was Frater Albertus (Albert Riedel). I asked him what books he might recommend. His reply was, "Sorry, but I got all my knowledge from personal teaching and by working hard and finding it out."

There were 20 people in attendance for the weekend. About half were LPN members, and so I was able to personally meet some of the members who were names and voices on the phone, which is always a treat. As in all such meetings there was the tremendous excitement when old and new friends meet and exchange

ideas on Alchemy and esoteric studies in general.

Since this was the first such workshop in the U.S. for Dr. Nawrocki, he decided to structure the weekend around the 7 Hermetic principles. **The Kybalion**, a book on the seven hermetic principles, will give you more information on this. The Saturday session was spent describing and applying the first 5 of these principles. A considerable bit of time was also spent discussing the fact that several companies in Europe are manufacturing Spagyric products. We were also told of the plans of Phameres Europe which was started by PRS in the early 1980s. I was intrigued to hear that Phameres was still alive and well—at least in Europe. It is of historical interest to note that Phameres in the U.S. provided the original funding for the translation of the LPN lessons and was closed down once LPN-USA became self-sustaining, since the line of work it had started seemed to no longer have active support in the U.S. The objective of Phameres Europe revolves around support of spagyric teachings and research. In time there may also be production and clinical testing of various spagyric products.

Dr. Nawrocki often explains the teaching strategy which is

known as language of the birds. This is the technique of dissecting words and symbols to find the hidden meaning behind the commonly assumed meanings. As the day progressed, numerous hints in lab work were given for those who were interested.

The lab discussions centered around the plant stone and circulum, the work on tartar, and the water work. We also were given some very interesting insights regarding regression therapy, since Dr. Nawrocki has operated such a clinic for several years.

All in all it was a productive and exciting meeting with something in it for everyone attending. The personal contacts with others alone made such meetings worthwhile for me and I regard whatever teaching was imparted as a bonus.

Saturday evening most of us found our way to Art Kunkle's laboratory and home where we all got better acquainted or caught up on what has happened since we last met.

The Sunday session covered the final 2 principles and a good deal more on lab procedures. The special message of the day, however, was that Alchemy is not chemistry, but is a total transformation process. There is not a result in the lab without a commensurate change and growth in the self.

---

## 20TH CENTURY MASTERS... (continued from page 10)

It takes WORK! and lots of it! More work than most of us can muster. The Great Work is called the Labors of Hercules for a good reason. This does not mean that we should give up the goal of achieving what the alchemists of old have produced through their industry and talent. The old arts and indeed alchemy are only lost to the person lacking a perception of an ever-present and obvious truth; a truth can only be experi-

enced personally, guiding the aspirant and knowledgeable student safely and boosting him in the ascent of the Mystic Mountain. Each step must be sure, before the next one is taken. This carefulness in climbing the steps leading beyond the clouds is required of everyone who places his feet upon the Royal Road of Alchymia.

"When we shall do it, it shall be done." (Frater Albertus)

**Dr. Nawrocki's essential thoughts on the perfection of attitudes for optimizing spagyric results. Article written in 1991. Now translated from the German. 30 pp., \$15 + \$1.50 shipping.**

**Order from:**

**Daniel Beilin, O.M.D.  
9057 Soquel Drive, A-B  
Aptos, CA 95003**



# THE SUN, MOON AND PLANETS IN THE CONSTELLATIONS

[from March 22, 1991 through August 22, 1991 at 0:00 hr (midnight) Greenwich Mean Time]

## SOLAR

Mar. 22, 1991	00°52'♈	June 22, 1991	00°06'♄
Apr. 22, 1991	01°23'♈	July 22, 1991	28°43'♄
May 22, 1991	00°26'♉	Aug. 22, 1991	28°26'♄

## PLANETS

	♃	♄	♅	♆	♇	♈	♉	♊	♋
Mar. 22, 1991	18°00'♈	03°45'♈	23°46'♉	03°40'♄	04°24'♃	13°30'♊	16°33'♊	20°10'♈	24°54'♊
Apr. 22, 1991	19°39'♈	10°31'♉	10°18'♄	04°20'♄	06°20'♃	13°49'♊	16°46'♊	19°30'♈	23°15'♊
May 22, 1991	06°29'♈	14°15'♄	27°22'♄	07°31'♄	06°49'♃	13°22'♊	16°29'♊	18°40'♈	21°40'♊
June 22, 1991	05°59'♄	15°13'♄	15°42'♄	12°38'♄	05°51'♃	12°19'♊	15°49'♊	17°56'♈	19°04'♊
July 22, 1991	25°31'♄	05°22'♈	03°59'♈	18°41'♄	03°53'♃	11°08'♊	15°00'♊	17°35'♈	18°56'♊
Aug. 22, 1991	28°11'♄	29°46'♄	23°26'♈	25°24'♄	01°41'♃	10°10'♊	14°19'♊	17°44'♈	18°29'♊

## LUNAR PHASES

	MAR			APR			MAY			JUN			JUL			AUG		
	DY	HR	MN	DY	HR	MN	DY	HR	MN	DY	HR	MN	DY	HR	MN	DY	HR	MN
New Moon	16	08	10	14	19	38	14	04	36	12	12	06	11	19	06	10	02	28
First Quarter	23	06	03	21	12	39	20	19	46	19	04	19	18	15	11	17	05	01
Full Moon	30	07	17	28	20	59	28	11	37	27	02	58	26	18	24	25	09	07
Third Quarter	08	10	32	07	06	45	07	00	46	05	15	30	05	02	50	03	11	25

## MOON AT 0:00 HR. (MIDNIGHT) (Mar. 21 through Aug. 21, 1991)

03/21	00°14'♉	05/06	03°33'♃	06/20	08°09'♈	08/05	01°49'♉
03/24	12°39'♄	05/09	10°31'♈	06/22	03°28'♈	08/07	00°45'♄
03/26	10°37'♄	05/11	07°02'♈	06/25	09°50'♈	08/09	00°32'♄
03/28	08°10'♈	05/13	05°22'♈	06/27	03°32'♊	08/11	00°15'♈
03/30	05°05'♈	05/15	04°58'♉	06/30	09°01'♃	08/14	12°38'♈
04/01	01°03'♈	05/17	04°48'♄	07/02	03°08'♈	08/16	08°46'♈
04/04	08°03'♈	05/19	03°52'♄	07/05	11°03'♈	08/18	03°26'♈
04/06	01°48'♊	05/21	01°42'♈	07/07	08°09'♈	08/21	09°03'♊
04/09	07°34'♃	05/24	11°13'♈	07/09	06°55'♉		
04/11	02°30'♈	05/26	06°23'♈	07/11	06°55'♄		
04/14	12°47'♈	05/28	00°50'♈	07/13	07°09'♄		
04/16	11°23'♈	05/31	06°33'♊	07/15	06°29'♈		
04/18	10°31'♉	06/02	00°09'♃	07/17	04°10'♈		
04/20	09°23'♄	06/05	06°23'♈	07/19	00°10'♈		
04/22	07°29'♄	06/07	01°58'♈	07/22	06°51'♈		
04/24	04°47'♈	06/10	13°38'♈	07/24	00°32'♊		
04/26	01°18'♈	06/12	13°24'♉	07/27	06°03'♃		
04/29	09°39'♈	06/14	13°42'♄	07/29	00°13'♈		
05/01	04°11'♈	06/16	13°20'♄	08/01	07°48'♈		
05/04	09°53'♊	06/18	11°32'♈	08/03	04°11'♈		

**NOTE: These tables are calculated and published for the purpose of determining optimum planetary configurations for particular alchemical operations.**

## IN THIS ISSUE

**Superstition & Alchemy.....1**

*Jean Dubuis*

Knowledge and pseudo-knowledge on the alchemical path.

**Bhasma of Zinc.....2**

*Anthony M. House*

A look at Indian Alchemy as taught by Dr. Junius at the Summer 1990 seminar in Dallas, TX.

**The Summer Teachings of Dr. Junius.....3**

*Anthony M. House*

Find out what really happened in Tioga this summer, then try it at home!

**Spagieric Lab Notes.....5**

*Paul Baines*

Continuing from the last issue; more detailed notes on the plant work of LPN.

**Tips for the Lab.....10**

*Paul Baines*

Glassware cleaning secret.

Send your submissions (photographs, drawings, charts and graphs are encouraged), advertising, ideas and comments to: **Ken Miller, 405 West Washington St. #314, San Diego, CA 92103.** Remember, all dues, donations, and questions about your membership should be addressed to LPN-USA, P.O.B. 111218, Boulder, CO. 80301.

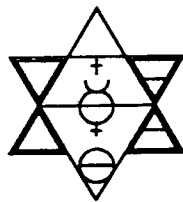
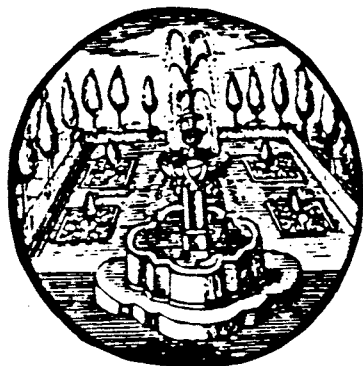

# The Stone

Issue Number 4

Fall 1991

## PATIENCE IS A VIRTUE

From the list of virtues needed to succeed in this chymical art, patience is surely near the top of the list. And I thank all of you who have waited patiently for this issue. Please note that while this is issue #4, it is only our third publication. Last issue was listed as #2 & 3. I spell this out so as not to confuse you.

Our goal in producing this little gem is to create a forum for people to exchange ideas. We have fallen short of our goal in that no one is contributing! Please collect your thoughts together and write us something. Anyone who wants to network simply needs to write up a brief description of your interests along with your address and/or phone number and I'll include it in the next issue. Be sure and use the San Diego address listed below to the left.

The Stone is published twice a year, in the Spring and Fall, near the equinoxes.

## SUPERSTITION & ALCHEMY

*By Jean Dubuis*

In all our works we insist, sometimes heavily, upon the necessity to be free in order to advance on the Path of Initiation.

In addition to adherence to religious or political ideologies which can be restrictive to mental freedom, there is another important restrictive element of inner and mental freedom: superstition.

Superstition is a "reverse" knowledge. Wisdom grows from

the confirmed value and exactness of an experience of Knowledge. Superstitions are pseudo-knowledge, received through hearsay and experimentally untested by those who transmitted them or received them.

Obviously, in the realm of knowledge that cannot be directly verified by experience, one should not reject everything. And so a

( continued on page 2 )

*The Stone*, Issue Number 4, Fall 1991. Published twice a year by LPN-USA. Editor: Ken Miller; Circulation & Gentleman Nudger: Kevin Townley; Executive Director: Bill Van Doren. Copywrite 1991



## SUPERSTITION & ALCHEMY

(continued from page 1)

double attitude is required: first, we must strive, if possible, to verify the transmitted information; and second, while waiting for this verification, this knowledge - or pseudo-knowledge - should not hinder our initiatory journey.

For example, in alchemy: in the realm of "metallic agriculture", the seed's development requires a constant temperature sensibly identical to the temperature maintained by a broody hen. In ancient times, the alchemist had an assistant who, with him, would constantly watch his "fire." Nowadays, it is impossible for most of us to have an assistant. So the use of an electrical incubator turns out to be very convenient. But when we claim to the ignorant "traditionalists" that the heat released by electricity, (natural energy), has the same effect as the heat released by the fire, we start a scandal. Yet, we observe that animal life develops correctly in the electrical incubator and the chicks are born alive. It is therefore hard to understand that the result would be different for the metallic alchemical child.

Besides experience, one of the keys that can help to estimate whether we are in the realm of superstition or of knowledge is the fact that many superstitions come from an exaggerated or unjustified attachment to the past, including customs and beliefs.

Consequently, let us be watch-

ful and meditative, and if some unproven elements are a hindrance on the journey of our initiatory advance, let us not hesitate to free ourselves from it. Again, let us not be in love with our concepts to the degree that we cannot let them go without regret when we find better ones!



## BHASMA OF ZINC

by Anthony M. House

In the summer of 1990, Michael Junius taught how to reanimate a dead metal. Bhasmas, which are chemically viewed as being oxides of metals, albeit erroneously, are organo-metallic compounds.

The first step in making a bhasma is *shodhana* = purification and destruction of the dead metal.

His words were: "We start out with chemically pure zinc, we make it alchemically pure by making it impure chemically. In this way, we are making organic rings around the metallic atoms."

### THE PROCESS ON ZINC (a protective medicine)

Malleable plates of zinc were placed in a stainless steel spoon (one can also use iron) and melted over a propane flame. Approximately 360°C. Protective goggles and leather gloves are essential for this work.

In a Corningware dish we poured some buttermilk, about half full. Over the dish was placed

a protective cardboard covering with a hole cut in its center, through which the melted zinc should be poured. The cardboard stops any palpable over-spraying.

As the hot zinc is poured through the hole into the buttermilk, it immediately sizzles and cools. It is absorbing the organic acid contained in the buttermilk. This mass of coagulated zinc is then washed off with water and again melted over the flame. Once again it is poured into the dish and coagulated. Then washed.

The whole process was repeated

( continued on page 8 )

## CORRECTION

In the last issue of The Stone (issue #2 & 3) an advertisement for Triad Laboratories contained several errors. Member Russ House has notified us that there is no antimony, stibnite, nor sulphur ore available for sale at this time. We regret any inconvenience you may have experienced.

## THE SUMMER TEACHINGS OF DR. JUNIUS

*as recalled by Anthony M. House*

*additional material by Ken Miller*

In post-Albertus America, the opportunities to study with a "master" alchemist are few and far between. There may be "masters" lurking around, but none seem to teaching in public at the moment. Hence, when a Junius or Nawrocki comes to the USA people come from around the country to hear them. Almost everyone I've talked with gained tremendously from the two seminars lead by Manfred Junius, author of Practical Handbook of Plant Alchemy. This article begins a series which will try to outline specifically what went on these past two summers in Texas.

Before we begin, let me state that what follows is written to the best of our recollection; and therefore may contain errors. It is a strange phenomena in this work that two people sitting next to each other can have radically different notes from the same lecture. "I heard him say this!" is often countered with "No, he distinctly said that! See I have it here in my notes." You get the picture.

This year the seminar participants met at the so-called "Healing Springs Ranch" in Tioga, Texas. This little town is a good hour or two north of Dallas. Once everyone adjusted to the rustic accommodations and basked under the Venus, Mars, & Jupiter conjunction, the seminar began.

### Circulatum Minus

Once again, Michael (as he prefers to be called) demonstrated his circulatum, extracting both fresh basil and fresh cypress tree.

In his demonstration, we cut some fresh cypress tree from outside, and he immediately immersed it in a test tube containing his circulata. With a little shaking, it quickly obtained a tincture (green), and then an emulsion of oil formed. He'd hold the test tube upside down with the cypress oil (dark green) flowing down into the liquid emulsion. Last year, the basil gave emerald green pearls or globules of oil.

Michael repeated: "If you tell an organic chemist that you can split off an oil from a plant with an alkaline derivative, they'll reject the theory, or notion." Yet his circulatum does just that! This alkaline derivative, is considered by the organic chemist as an anomaly of nature.

We also tried using last years rosemary magistry to extract some fresh cypress. We hoped that the quality of the magistry was such that it might have been a circulatum. Alas, a beautiful tincture was obtained (from the spiritus vini), but no oil.

Michael told us that his best circulatum came from cedar tree and Canadian balsam.

We were told that circulata gain strength by repeated use and successive distillations. That is, the product is strengthened with each extraction. After separating the oil one can then distill the circulata over and have a more powerful product. This is the secret of multiplying the circulata. After it has been potentized by repeated use, spiritus vini can be added to it increasing the volume of liquid.

Not to be fooled around with, some of the circulatum was spilled unwittingly on the countertop, which later was discovered to have partly burned an impression into it!

The Two Main Projects for 1991:

### GREEN LION

This year we were shown a method practiced by Betty McKaig for making a Green Lion. A perfect fusion of magnetic iron ore and copper.

Michael brought with him pictures of his attempts to reproduce her method for the green lion. As well as an excerpt from her communications written about it. This was handed out to us all.

In the alchemical bestiary this creature holds a special place. Once it's been properly made it becomes a jumping off point for great circulatums and the produc-

( continued on page 4 )

## TEACHINGS OF DR. JUNIUS

(continued from page 3)

tion of the Philosophical Mercury in the metallic kingdom. Michael said care needs to be exercised in thinking about green lions as classic authors use this term to designate a variety of substances or processes. Our work was to be "a" green lion, not necessarily "the" green lion you may read about in a particular text.

Our Green Lion is a Mars/Venus Magistery. Most important in its production is the perfect fusion (joining) of magnetic iron ore and copper.

We were to have heavenly help for this work, and Michael explained the need to cooperate with the conjunction of Mars and Venus in the constellation of Leo, which was occurring most powerfully from June 23 through the 30th, the week of the seminar.

We were shown a piece of pyrrhotite and its magnetism was demonstrated with a compass. The needle moved by holding the specimen over it and moving back and forth. The iron's lode was verified this way.

We were told that the energy for the work would come from this ore. We took it outside and there finding a suitably sized rock with a flat surface, smashed the pyrrhotite into small bits with a hammer. It was unnecessary to grind it up any finer. Most of the participants took turns in the smashing, an attempt to put the group energy into the project.

### PROCESS FOR THE GREEN LION

Materials used were:

Concentrated sulfuric acid (vitriol) 360ml

Distilled rain water 1680 ml.

Pyrrhotite (magnetic iron ore) 125 gm.

Copper (raw ore or filings) 187 gm.

Iron filings (ground fine) 62 gm.



We slowly added the sulfuric acid to the rain water. Drop by drop, 10 ml. at a time, from a pipette. Each person in attendance was asked to add their energy and drop 10 ml. until we reached a total of 360 mls.

The temperature of the rain water and acid reached approximately 154°F. This was slowly poured over the contents of a wide mouth flask containing the layers of pyrrhotite (on the bottom), raw copper samples and copper turn-

ings, (in the middle), and iron filings over the top.

As the reaction began it bubbled up and started to smell very bad. **Danger! Sulphur dioxide. Don't breathe this.** Anecdotes were shared about beetles and bugs, being attracted to the smell, crawling into the flask thereby ruining a good alchemist's work! Cotton was gently stuffed into the end of the alembic hood we attached to the flask neck to prevent this from happening to us. The whole thing was set in a sand bath, when the reaction settled down.

The sandbath was set on a lab jack so that we could quickly drop it down in case of to great a reaction from its heat.

Approximate heat 325F.

Adjustments in temperature were made based on observation of reaction. To test the strength of the remaining acid mixture we added some more copper turnings in small proportion to see if it would tarnish.

Michael sat by it all day, and we sat around him and discussed it and many other subjects including, qabala, magic, medicine, music, mercury, science of chemistry and physics, astronomy, astrology and so on.

He told us we could also work the Lion under a trine of Mars and Venus or with a favorable sextile. No squares!

( continued on page 6 )

## SPAGYRIC LAB NOTES

by Paul Baines

### Third month's work

The salt from experiment one (see last issue--ed.) was placed in a 100ml RB flask "A" with a ground glass stopper. Twenty mls of Melissa tincture was poured over it and the flask placed into a constant temperature bath. The salt from experiment 2 was likewise treated and placed in flask "B."

The constant temperature bath consists of a cheap plastic fish tank filled with water and kept at a temperature no more than 40°C by means of an electrothermal 'Red Rod' silica sheathed immersion heater. The heater is connected to the main power supply via an electrothermal temperature controller and a Smith's safety relay cut-out. This cut-out is an essential safety device, instantly cutting off the current should water enter the heater which would otherwise render the bath live. A small amount of Calgon is added to the water in the bath to prevent hard water deposits forming on the heater. The temperature of the bath is monitored by a thermometer suspended in it. The flasks are held in place in the bath by means of a suitable arrangement of stands, rods and clamps.

After three days the flasks were removed. The tincture in each had become considerably darker and possessed an odor peculiar to this type of spagyric preparation. The tinctures were

filtered and the salts were retrieved, which by now were virtually black. The salts were dried and each calcined separately overnight. Salt from "B" appeared gray and never did revert back to pure white.

The process was repeated. The tincture in flask "A" did not become discolored, so, after calcination, the salt was stored in a closed jar and the experiment discontinued on this sample. The process was reiterated twice more on the salt from flask "B" which continued to impart a distinct discoloration to the tincture with undiminished vigor.

The experiment was discontinued after the fourth cycle since the quantity of salt diminished, some of it going into solution at each maceration. Since the solubility of Pot. Carb. in water is 1 in 1 and its solubility in alcohol nil, it follows that a 60% alcohol solution will dissolve a certain proportion of the salt.

After a few days the treated tincture had thrown down a black deposit which was filtered off and calcined with the rest of the salt. In preparing simple spagyric tinctures for dispensary I have noticed that once the tinctures were percolated through the calcined salt, they would throw down a black deposit. My interpretation was that this was a separation of the gross matter (impurities).

The experiment has now been discontinued.

### Preparation of pure alcohol

For this exercise the starting material was approximately 4 litres of home brewed red wine produced from grape juice concentrate to which no extra sugar was added.

The first distillation was a rough separation employing a 2 litre RB flask heated directly on the hot plate. Jointed glass components were used throughout on distillation rigs. Everything that came over below 95°C was collected.

The first rectification was carried out using a 500ml flask heated on a water bath. All rectifications should be heated on a water bath. The alcohol came over at 81°C. Test for purity - dip a wick into the spirit and ignite. If the flame 'sticks' to the wick there is still a lot of water present.

The next three rectifications were conducted using a Vigreux column. The column was first wrapped in baking foil and then lagged with polyester foam. On this occasion the alcohol distilled over at 78°C exactly. Once the alcohol had come over, the temperature at the stillhead began to drop since the water vapor alone was unable to rise that far up the column. There were no first runnings observed to come over before 78°C was reached.

If the fractioning column is not lagged it will simply act as an

## TEACHINGS OF DR. JUNIUS

(continued from page 4)

After it sat over night, the reaction was finished. We decanted and filtered, obtaining a brownish/green liquid. This was placed in a large dish, on heat at low temperature, to evaporate off a little liquid. Crystals formed as a crust on its surface.

We placed the dish and liquid into the refrigerator overnight. The result was perfectly formed jade colored crystals.

This was our fusion of the two sulphides of copper and iron, the Green Lion.

The Green Lion is considered the centerpiece of all terms in alchemical texts and is = to: Virgin's Milk, Universal Mercury, and so on. Many names have been given to this beastly, since many alchemists have tried to hide its production from the unworthy and to keep it hidden under so many names.

The medicinal use of it is as a vulnerary, to staunch wounds, cuts, etc. External use only. Wounds treated with it are said to heal over night and to not leave a scar.

Michael further told us it is both an end product and a product to use as a new point of departure for further work. A stepping stone.

This was evident by the excerpt we were given elucidating the lion, and by the commentary given verbally by Michael.

### MAGISTRY OF SAGE (*salvia officinalis*)

We set up an apparatus consisting of a 2000 ml. erlenmeyer flask, an oil separator, and a coil condenser. Distilled water was poured over the sage and allowed to steam distill the essential oil out.

After about 3.5 pounds were extracted the oil was in our possession. Between changing the extracted herb with fresh sage, the water or juice was poured off through a filter.

This "soup," was to be our salt of sulfur.

The filtered herb was later ashed and most of the carbon was removed by slow calcination. The grey ashes were placed in an electric kiln at a temperature of approximately 900°F.

3-4 hours of further calcination brought the salt of salt to the point where the leeching of the water soluble salts could be extracted.

After leeching, the separated water soluble salts were ground finely and placed into the oven again.

We utilized the gas oven in the kitchen, appropriately named "Vulcan" to reduce the soup to a thick gooeey mass which was scraped into a dish and was fired and calcined in the kiln as well.

This was reduced to a grey ash after passing through the carbon

stage of black.

It was leached and the water soluble salts were placed into the oven along with the salt of salt. These two were both fired at

500°F. overnight 6-8 hours.

Much vigilance and careful grinding had to be exercised to obtain the very white salts which we were rewarded with.

Michael called it "master work."

Last year when rosemary was used, Michael was involved throughout the work, detailing the necessary steps involved for its production. However, this year he stood back and let us do all the work, to see if we could do it.

The salts thus prepared were kept warm in their respective separate dishes, to keep them from drawing moisture into them until we could transfer them into a 500 ml. erlenmeyer flask for their cohobation.

Cohobation was commenced by pouring the two salts, the essential oil, and spiritus vini into the erlenmeyer flask. The amount of s.v. used was 210 ml.

The condenser was attached and reflux was begun at a temperature set for the vapors only to rise. It was not boiled.

After approximately 36 hours of circulation the heat was removed from the flask. In a short time (half an hour) a rare, and exciting occurrence manifested.

(continued on page 7)

## BASMA OF ZINC

(continued from page 2)

ted 7 times and the once malleable zinc became visibly altered in its quality. Interesting to note was that the zinc tinged golden on its surface and this was determined to be its interior sulfur. It was becoming very brittle and became easily broken up.

The next step was to add some spice turmeric to the brittle zinc and while stirring, it was placed above the flame once more.

The turmeric coats and protects the particulate zinc.

The alchemically purified zinc and turmeric gradually becomes finer and blackish in appearance;

soot-like. Small patties of this mix are placed in a crucible with another crucible placed on top of it, and the two crucibles are sealed to protect the contents from oxidation.

He told us "We must guard against making an oxide. We want an organo-metallic compound. No air must get into the crucibles."

At approximately 700°C. it is fired in a reverberatory oven.

In India, large pits are dug in the ground, and dozens of clay crucibles are "cooked" in it. The pits are filled with these crucibles, then covered by a huge mound of cow patties which, when ignited, provide a steady source of heat.

Bhasmas pass through three necessary stages.

1. Nigredo - at the point of the use of the turmeric (spice)

2. Albedo - grey color obtained from repetition

3. Rubedo - particulate organo-metal and turmeric eventually turn red

What's so important about this Eastern method of production is the transformation of a dead metal and its resurrection or reanimation. This again is done by forming organic rings around the metallic atoms, altering and loosening its structure, producing a colloidal-like refinement. *Amrit Karana* = "the nectar" - or medicine.

Some bhasmas such as those produced from mica, require reverberatory heat in a furnace or ground pit oven, repeated over a thousand times! Great patience is needed, and a lot of work. However, in India, and elsewhere, Junius explained there is no hurry, and the labor is done with love and understanding of its outcome.

He mentioned that Americans tend to want everything done yesterday! A good observation, well taken by the attendees as a lesson to learn.

Tests show that a good bhasma cannot be reduced further. And is therefore stable.

The technique used on metals can also be used on gems!

(continued on page 8)

---

## TEACHINGS OF DR. JUNIUS

(continued from page 6)

Just as last year, STARS had come out! One runs across this phenomena in the works of several masters, including Hollandus, and is somewhat difficult to describe. The liquid of the magistry looks as if it has vibrant colored crystals suspended within it, like stars as suspended in the sky. Red, green, blue... the sight is spectacular.

These stars are considered salt crystals in solution. Their gleaming brilliance is something to behold.

Michael told us that such stars are primarily from the organic acid contained in the essential oil reacting with the alkaline salts in concert with the s.v.

### Epilogue

In addition to the work already mentioned, Junius taught us meditation techniques, the Alchemy of Music, and answered just about every question asked, being frank when he did not know the answer. In the next issue we will continue to cover this additional material.

In Jacques Sadoul's book *Alchemists and Gold* he describes two types of true alchemy teachers: Grudging and Generous. Manfred "Michael" Junius has certainly proved himself to be most generous. We hope he returns in 1992.

## SPAGYRIC LAB NOTES

*(continued from page 5)*

air condenser and it is unlikely that the vapors will reach the stillhead.

Boiling points are given for an atmospheric pressure of 760mmHg. Variations of barometric pressure will therefore affect the boiling point of liquids. During a particular bout of low pressure I observed the boiling point of alcohol to be 70°C!

Alcohol forms an azeotropic mixture with water - i.e. the water and solvent will distil over as a mixture whose composition will depend on the ratios of their molecular weights and vapor pressures. Thus it is not possible to totally separate the alcohol by distillation alone.

Five grams of anhydrous potassium carbonate was added to the distillate and left for 48 hours. In this instance the pot. carb. did

---

## BASMA OF ZINC

*(continued from page 7)*

Although each metal or gem has its own unique formula of organic compounds.

He said that Ayurvedic bhasmas produced by this time-honored method could be purchased from a company called Rasashala, in Poona, India. Although it was stipulated that only licensed physicians could buy them.

not liquefy indicating that the fractional rectification was particularly effective. Usually the pot. carb. forms an immiscible liquid layer that can be separated by careful decanting. Other dehydrating agents can be used, such as calcium oxide, but at this stage we do not want to mineralize our mercury. In the lab, anhydrous alcohol is kept over metallic calcium to absorb traces of water. Alcohol, being hydroscopic, will draw to itself atmospheric moisture so that anhydrous alcohol, if exposed to the air will take on 4% water, being stable at 96.2%.

After decanting the spirit, it was once more rectified and then stored in a well stoppered bottle. Yield - 120ml.

To test for water in alcohol, place a piece of anhydrous copper sulphate in the alcohol bottle. The crystal will eventually turn blue if water is present.

## Extraction of Essential Oils

For this exercise Dutch caraway fruits (*Carum carvi*) were used. The fruits contain 3.5 - 7% volatile oil which in turn consists of 45 - 60% carvone. It is employed in medicine in the form of concentrated caraway water as a carminative and flavoring agent. It has been used in powder form in combination with purgatives such as senna and aloes to offset the griping effects of same.

**Sept. 6 1989**

First Wednesday after new moon. A sufficient quality of distilled rainwater was poured

onto two 200g batches of caraway fruits at sunrise. These were left to macerate, undisturbed, for forty-eight hours.

**Sept. 9 1989**

The macerated fruits were placed in a large reaction vessel fitted with a wire mesh support so that the fruits were supported above the water in the bottom of the vessel; this permitted the steam to permeate through the material. The reaction vessel was fitted with an essential oil estimator furnished with a graduated scale and drain cock. This in turn was fitted with a coil condenser and stop cock. This latter was closed once ambient temperature was reached in order to achieve a closed circuit. The tap was opened several times to release pressure that built up. A moments inattention allowed the stopcock to blow out and break on the floor. This immediately replaced by another stopcock which was left open for the duration of the extraction. At least the narrow aperture of the stopcock allowed the pressure to equalize with minimal loss of volatile constituents.

Extraction was allowed to continue for four hours by which time the oil level in the graduated tube remained constant. The heat was turned off and the apparatus allowed to cool. The oil was drawn off via the drain cock. The procedure was repeated with the second batch of macerated fruits.

The total yield of oil was 3.5ml, much less than was expected.

*( continued on page 9 )*

## SPAGYRIC LAB NOTES

(continued from page 5)

ted. The fruits were extracted whole in accordance with the directions in the Pharmacopoeia. It is felt, however, that a greater yield of oil may be obtained by extracting the crushed fruits. The fruits were again macerated for 24 hours and the extraction process repeated but no further oil was obtained. The oil was of a milky appearance at first but attained to a brilliant clarity on standing. The oil was preserved in a close stoppered bottle. In pharmaceutical practice it is usual to dry essential oils over anhydrous sodium sulphate. I have not done this as I am uncertain that this procedure would be permitted in spagyrics.

### Fermentation

The exhausted seeds, along with the distillation water, was placed in a glass sweet jar. The liquid portion was previously made up to 1 litre with additional distilled rainwater. Since caraway fruits contain no fermentable sugars it was necessary to add 200g of sugar and some yeast nutrient. Fermentation was commenced by adding a small quantity of commercial dried wine yeast. A small quantity of untreated fruits were added to the must to replace any missing elements removed during extraction. The jar was covered with a close weave cloth tied in place. The whole was put into a warm place to ferment.

Sept. 23, 1989

Fermentation complete. The material in the jar was pressed and filtered. The pressed seeds were placed in the oven to dry. The fermented liquid was found to be pH 4 and had a sour taste. It appears that acetifying organisms have contaminated the must. It is true that I had omitted to sulphite the fermentation vessel before use, a procedure which all good wine-makers insists on. This mishap has not happened to me until now, a case of familiarity breeding contempt. The rule to follow is to always sulphite fermentation vessels and allied equipment. Even had this procedure been followed, the use of a wide mouth jar with a cloth leaves the must vulnerable to invasion by micro-organisms. Fermentations are usually carried out in demijohn bottles fitted with an air lock. The wide mouth jar was used as an expedient to facilitate the removal of the large amount of solid matter involved. A wide mouth closure which can take an air lock would prevent future mishaps of this kind.

A further cause of aggravation arose when the lab was invaded by fruit flies (*Drosophila melanogaster*) evidently from outside, being attracted by the smell of the fermented liquor. There was no evidence of them during the actual fermentation besides which they would not have been able to gain access to the must.

Thus I offer the following rules to my fellow spagyrists:

1. Always sulphite ferment-

tation vessels before use. This will not interfere with the work provided you rinse out the vessels well with clean water before introducing the must.

2. Always use some kind of airlock to isolate the fermenting must from the outside air, but allowing CO<sub>2</sub> to escape.

3. It is a good idea to check the specific gravity of the must before and after fermentation in order to estimate alcoholic content. This latter is not essential to the success of the operation.

Despite this setback, distillation was commenced and a quantity of alcohol obtained. 100ml of distillate was set aside for rectification. A further 500ml of water was distilled off and set aside. The remaining honey like material was transferred to a porcelain dish and slowly evaporated until it began to smoke. This was done with a view to obtaining the salt of the fixed sulphur - re: Junius.

9/24/1989

The contents of the porcelain dish were damped with alcohol and ignited in the open air. After combustion had ceased, the material was removed and powdered in a mortar and the remaining carbon burned off in a kiln. This was done outdoors on account of the smoke involved. The dried fruits were likewise damped with alcohol and ignited. After combustion the whole lot was pulverized and the carbon burned off in a kiln. This was done in several batches over three

(continued on page 10)



## TIPS FOR THE LAB

by Paul Baines

A useful cleaning tip for removing organic deposits from glassware: Fill vessel with potassium permanganate solution and leave overnight to oxidize deposit. Pour out solution and place a small quantity of conc. HCL into vessel and allow to run round sides to remove brown deposit. Rinse out with several batches of clean water, and a final rinse with distilled water.

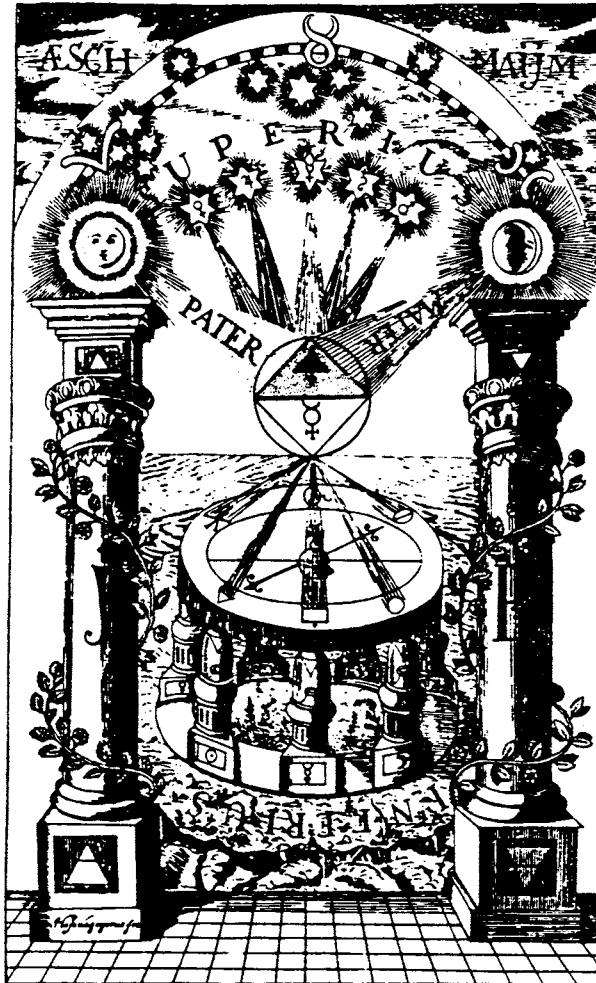

## SPAGYRIC LAB NOTES

(continued from page 9)

days. The gray ash remaining from both the sulphur and the fruits was preserved for further treatment.

(Ed. note: With great sadness I must report that Mr. Baines passed away earlier this year. He will be missed by many. He offered these notes for publication in the hope that they would help others. We will continue to print the remaining notes in future issues.)

## TAX DEDUCTIBLE CONTRIBUTIONS

Your donations to LPN-USA are now tax deductible. We need your help to continue the work; and there is a lot to do. There is material in need of translation, advertising costs, postage, etc. When you give to LPN it is a gift to yourself. We are here to serve you. Give generously, please.

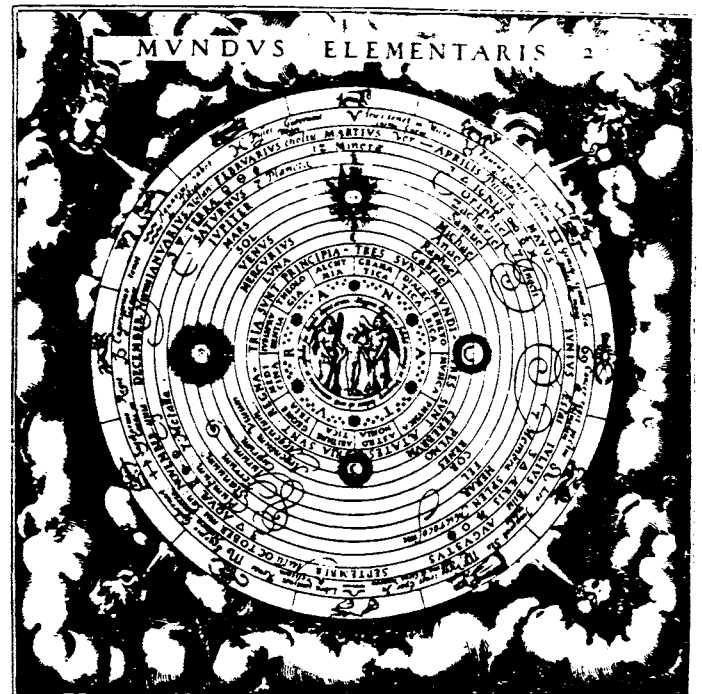

## IN THIS ISSUE

Nature & Alchemy.....1  
*by Jean Dubuis*

An editorial that first ran the French newsletter #35, April 1986.

Tincture of Tartar.....3  
*by Anthony M. House & Ken Miller*

Report on the work done at the Summer 1990 Junius workshop.

Dilemmas in Alchemical Language..4  
*by John F. Wright*

An analysis on the need for understanding the often culture-bound vocabulary of our work in its historical context.

A Call to Service.....7  
*by Kevin Townley*

A thoughtful essay written for the membership.

LPN Update.....9  
*by Bill Van Doren*

The latest news on changes in both the French and US organization.

Vacuum Fractionation.....10  
*by Paul Baines*

More lab techniques from the late Mr. Baines.

Membership Questionnaire.....11

Please, please fill out our questionnaire right away so that the organization may serve you better!

Send your submissions (photographs, drawings, charts and graphs are encouraged), ideas and comments to: **Ken Miller, 405 West Washington St. #314, San Diego, CA 92103.** Remember, all dues, donations, and questions about your membership should be addressed to LPN-USA, Box 11218, Boulder, CO. 80301.

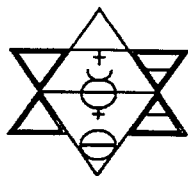
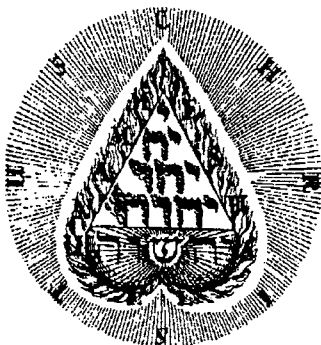

# The Stone

Issue Number 5

Spring 1992

## Spring into Action

The LPN has been going through some changes lately, as you'll read later. One thing that has not changed is our commitment to you. In an effort to better serve, we've enclosed a questionnaire at the back of this issue. Please take the time to fill it out now, this is very important.

Again, I ask if you have any material you would like published here, please submit it to the San Diego address. The Stone is a forum for the membership and few people are taking advantage of it. We would like to return to a quarterly format and need your input for material!

As to the network idea mentioned in the last issue, no one responded. So I can conclude only that no one is interested at this time. Which is a shame, particularly in our field were there are so few of us to begin with.

Future issues of The Stone will be getting bigger and better with the appearance of more provocative articles for your stimulation.

Until next time, have a fruitful and enriching summer!

## Nature & Alchemy

*by Jean Dubuis*

Nature was created to allow for involution and evolution of Beings in the mineral, vegetable or animal Kingdoms. The meditation and study of Nature's methods and actions shall reveal useful principles for our spiritual progress.

If we deal with alchemy, then the study of plant germination will shed a light on the method of metallic alchemy. This statement is so accurate that many alchemists call themselves "farmers." The alchemist will find in the animal kingdom, particularly in the study of oviparous animals, a few of the secrets of the philosophic egg.

The student will find analogies between the study of Kabala and that of Nature, that will permit him an understanding of the laws of creation. For example, the study of electricity - an invisible energy - shows the action of the invisible upon the visible. It also shows that this energy can

(continued on page 2)

*The Stone*, Issue Number 5, Spring 1992. Published twice a year by LPN-USA. Editor: Ken Miller; Printing: Kevin Townley; Circulation: Karin DiGiacomo; Executive Director: Bill Van Doren. Copywrite 1992

# NATURE...

(Continued from page 1)

have various effects: it provides movement, heat, light, and chemical modifications.

Meditation on the invisible energies which can be perceived in our world leads to a certain realization of the bond which unites the non-manifested Ain Soph to the created world.

The duality due to the differentiation of primary energy, the rule of the manifest world, is reappearing in the vegetable realm: Symmetry of leaves and flowers and in the animal world: body symmetry.

The Gematria of the Kabala can be used in the vegetable kingdom to count the different elements of plants, for example the number of petals, leaves, etc. This enumeration makes the assignment of the vegetal to a Sephirah possible (the origin of the signature theory.)

The study of the lunar and solar cycles will provide a basic notion of the most obvious actions of the cosmic forces of these two luminaries.

This shows, in fact rather summarily, that the study of nature's models provides every one with the first notions of the knowledge tryptic; because, if the knowledge of the true adepts is unitarian in its inner expression, on the other hand, it is trinitarian in its intellectual expression, that is to say: Natural magic or Kabala, Alchemy and Astrology. But the communion with nature brings the first inner

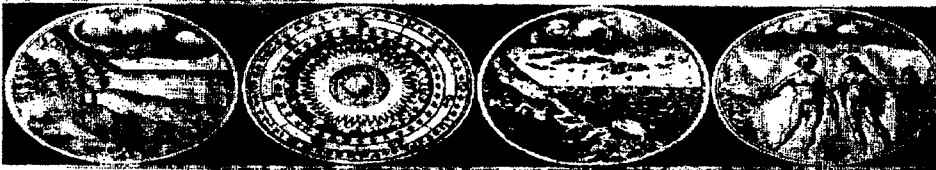

realization without undermining personal freedom.

The nature which teaches us is like an outer master, or better yet, like a model which can inspire us in our esoteric work. There is no other master except our inner self, our inner Master. This doesn't exclude teachers or experienced individuals who can act as guides so that an individual who started on the path of reintegration may avoid a few tricky passages.

Whoever is in conscious contact with the invisible world will never accept the title of Master or Guru, for the help must be brotherly among the children of the Being.

We tried and will continue to make it clear to our members that we must strive to remain free, to not obey a so-called master. The student who is ready should present himself free and alone at the gate of the temple.

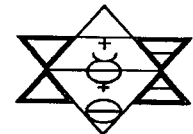

-advertisement-

## Qabala/Alchemy Classes in the Dallas Area.

*Classes offered periodically that teach the fundamentals, principles, terminology and techniques in Alchemy & Qabala. This is an opportunity to learn from a living teacher who has done it before. These seminars offer hours of practical, usable information with plenty of handouts and "hands on" classroom and labwork. For further information and dates of upcoming events, contact:*

**Hans. W. Nintzel, 733 Melrose Drive, Richardson, Texas 75080**

**home tel: 214-238-9877, work tel: 214-330-3207**

Mr. Nintzel holds a degree in engineering, has been a computer analyst, has studied for his MBA at UCLA and holds an honorary PhD in Humanities. He studied seven years with Fratar Albertus and Dr. Israel Regardie was one of his mentors. He has been published in FATE and Gnosis magazines.

English translations of rare alchemical manuscripts are also available! Please inquire.

# Tincture of TARTAR

by Anthony M. House & Ken Miller

Continuing our review of what happened during the two Junius seminars, we describe in this issue (to the best of our recollection), the tartar work that was done in the summer 1990 workshop.

## There are two types of tartarii:

1. Raw - it is cleansing and can be used as a laxative.
2. Calcined - it's used for higher alkaline magisteries.

It is a borderline substance, as is antimony, that can translate up and down the kingdoms. They are so-called middle substances.

Our work on tartar entailed its calcination from raw material, and its extraction, both by dry distillation of the raw tartar, and by adding its own alkahest (Spiritus Tartar) to the blue (calcined) salts circulating or digesting in spiritus vini, to obtain a red tincture; the tincture of tartar.

## The Blue Tartar

The raw material, the tartar itself, is obtained from wooden wine caskets, a disappearing commodity as wineries increasingly utilize modern methods. To get the "blue tartar" the salts must be calcined at high temperatures until a blue, green, or perhaps even a pink color is revealed. Place this result on a dish and heat until it is black as coal. Add distilled water, filter, then evaporate the water until your product is white. Now further calcination results in the "blue tartar."

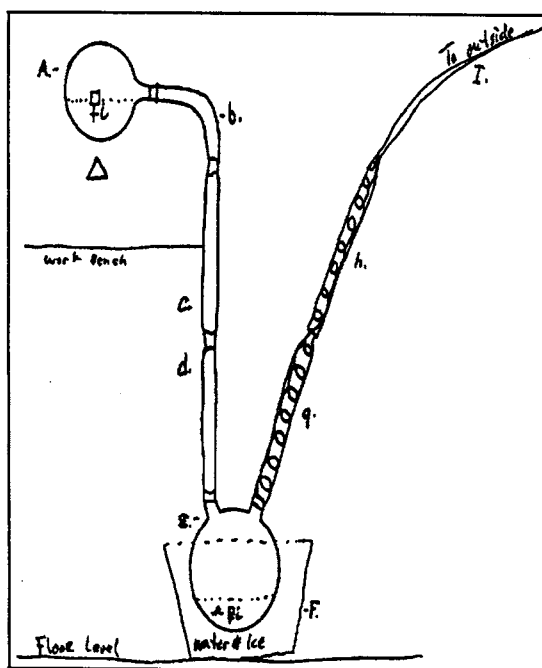

## The Spiritus Tartar

With this apparatus we dry distilled red raw tartar. Use a gentle fire at first, then slowly increase the temperature. The heat from the flame produced white smoke, much like the lead process, which was condensed in the bucket (F) and in the condenser's (g) & (h). A yellow alkahest floated on the phlegm and a residue of red stinking oil was obtained. This stinking oil is very carcinogenic, but can be purified into a useful topical medication.

He told us that four separate phenomena were produced by this work, and these four fractions open up all the many realms.

1. Humidum - phlegm
2. Acidum - Yellow spirit tartarii
3. Oleum combustibile - dark red stinking oil
4. Sal Armeniac - sharpens alcohol (eagle)

The first three phenomena happen simultaneously, while the fourth can occur sporadically throughout the distillation and is

(continued on page 5)



Dr. Manfred Junius sampling the vapors a Sage Magestry; Tioga, Texas, Summer 1991

# Dilemmas in Alchemical Language

by John F. Wright

There exists in the English language a term, first used in 1962 by Thomas Kuhn in his book *The Structure of Scientific Revolution*, known as the Paradigm. A paradigm is more than a theory (or system of theories) in a particular branch of "science". It is almost a world view, a way of seeing the world through the spectacles provided by that science. Such a paradigm has important social elements. Young "scientist" are educated in such a way that their thinking is molded so that it meshes with generally received views dictated by the paradigm. They work on textbook problems, which teach them to think in accordance with the paradigm way. Textbooks present science as achievement, as a body of facts. Learning to think in accordance with a particular paradigm is essential for membership of a particular scientific community.

It is not therefore surprising to find science considering alchemy as pseudo-scientific nonsense claiming to produce a Philosophers' Stone which either transmutes base metals into gold or gives us the Elixir of Youth. Most individuals have never seen an alchemical tract in their life, and those who have are blinded by their own paradigm to take the first steps to cut the Gordian Knot.

What is equally frustrating, is the tendency to interpret such manuscripts in terms of a modern paradigm, that of psychology. The number of books "solving" the complex interaction of symbols by incorporating modern Jungian

symbols I feel undermines much of the material, which, whether it holds deep esoteric mysteries or is merely a stage in the development of chemical theory, deserves more respect than this.

A problem many face, when introduced to alchemy for the first time, is the language used. How to overcome this problem is actually given by many of the authors themselves:

"There is no way in which this art can truly be found...except by completing your studies and understanding the WORDS of the philosophers". (Ricardus Anglicus, *Correctorium alchymia*).

In the *Turba Philosophorum*, Parmenides advises the student to study books constantly; this detailed examination of writings was an extremely important feature of alchemy.

Even in the earliest Greek alchemical texts we notice that there is a noticeable pre-occupation with finding out the MEANINGS of the WORDS of the ancient authors. e.g. those aphorisms attributed to Hermes.

Geber in the beginning of his *Sum of Perfection* advises the readers to "labour studiously in Our Volumes, and endeavor to ponder them very often in your Mind that you may acquire the True Intention of Our Words."

A seventeenth century work gave the following advice: "Read, and think over what you read. If you make nothing of it, read the same books over again, then read

other books; for the last which you read will be able to provide you with the meaning of all the others in the same way that those which you read first will enable you to understand the later ones." (*Text D'Alchimie* 1695).

Such advice should be taken but in context of the period it was written. It is apparent that some modern authors interpretations are influenced by other considerations. For example, how can the meanings of words used in a medieval tract be matched directly with those terms used by, for example the Golden Dawn. Interpretation using modern esoteric systems can be detrimental to the understanding of the texts.

Language has emerged as a central concern to many subjects, alchemy being one of many. Some philosophers share the basic belief that a philosophical problem was a "product of the unconscious adoption of assumptions built into the vocabulary in which the problem was stated." We must investigate how the alchemists used language, than to try to immediately isolate ideas and concepts.

For the sake of simplicity, I shall distinguish the three main approaches or attitudes to language.

SYMBOLIC

HERMENEUTIC or SEMANTIC

RHETORICAL

The first studies language in terms of the object to which it refers. The second interprets as a system of meanings. The third as a way it serves the interests of the authors.

(continued on page 6)

# TARTAR

(Continued from page 3)

difficult to catch. However, with a little ingenious engineering, one could build an eagle's trap to capture this most volatile gas, which tries to escape out of the hose leading outside (l). This Sal armeniac appears like an ethereal salt, visible for a moment only to vaporize with the next wave of distillate cascading down the condensers from the flask; obviously extremely hygroscopic. The class witnessed it appear and disappear in sections (c) & (d).

## The Tincture

Michael put three drops of this spirit tartarii (a yellow liquid) into the digestion flask of alcohol-tartar salts. Instantly, the red tincture emerged from the salts interior. Thus we had the red tincture of tartar. A great cleansing medicine. He mentioned that spiritus vini & blue tartar can be enough to create the tartar tincture, but in our case the yellow liquid was necessary.

## Other uses of the alkahest

In lesson 6 of the LPN mineral material we find that the alkahest of tartar can be used to obtain the tinctures of iron, copper, mercury, silver and gold starting from dead but pure metals.



Member and frequent contributor to The Stone, Anthony M. House basks in the glow of the Sage Magestry

This year (1991) he showed us a vial containing alkahest of tartar and gold particles inside. He had obtained a tincture from gold that was not pure as it had some silver and copper trailings in it. This tincture, he said, should not be used for medicine. Only the purest gold should be used as a medicine.

Michael related that gold and the Sun have a great affinity, as the ancients claim. To prove this he said we could place the gold tincture extracted by the tartar alkahest in the direct sunlight and the tincture would be absorbed by the rays. The alkahest becomes a clear fluid again by this action.



## TAX DEDUCTIBLE CONTRIBUTIONS

Your donations to LPN-USA are now tax deductible. We need your help to continue the work; and there is a lot to do. There is material in need of translation, advertising costs, postage, etc. When you give to LPN it is a gift to yourself. We are here to serve you. Give generously, please.

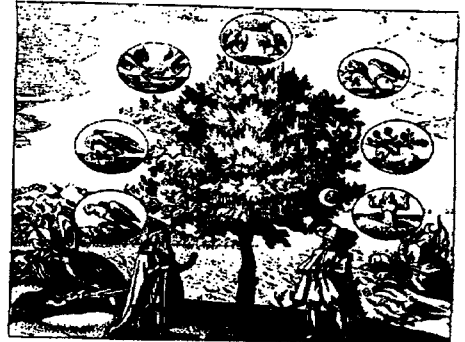

## TARTARUS SAYS OF ITSELF:

*"I call myself of vegetable origin  
the strong wines know me  
very well  
if I am added to the other  
salts  
I will lead them to the key  
of the next  
higher kingdom, for I can  
unlock  
metals."*

# DILEMMAS

(Continued from page 4)

These categories are intended to aid analysis rather than restrict it. I should point out that very few texts fall directly into one specific type - most are amalgams of the three approaches.

The 'symbolic' approach takes as its object of study the way that language exercises its "function as a system of symbols." It starts from the assumption that language is a means of symbolic communication. Rather than seeking to grasp the meaning of the symbol itself, it concentrates on understanding the meaning between the symbol and the thing itself. Such studies should be made in the light of how a particular author uses a term, e.g. Paracelsus' "sulphur," or by others in their cultural period, e.g. Gerber's work in the light of his cultural upbringing, not through Christian tinted spectacles.

For such example let us consider the swan. In the sixth Key of Basil Valentine the song of the dying swan varies the theme of death and rebirth expressed by the copulation of the winged and wingless birds. The swan is taken as a classical emblem of the albedo because of its wings and immaculate whiteness. As the legend of Leda and the Swan, the bird is also a symbol of divine union. In addition to the conjugal implications of the swan, the spiritual and transcendent nature of the bird is apparent in its wings of heavenly flight and divine sound. In antiquity, swans were honoured as the sacred birds Apollon, the god of music, spirit and beauty.

Another alchemist quotes, "The old masters were wont to call their work the white swan, their albefication, or making white, their sublimation, distillation, circulation, and purification," (John Porage).

What is apparent is that the cultural aspect of the individual and the period influences the symbolism used. The bridging together of separate ideas into one scheme will create great difficulties. How can any individual use this same material to infer that the author is implying "this is merely a first conscious encounter with the etheric world, and in comparison with physical sense experience is for many so overpowering as to be pictured as bright white light." Such views may be inferred perhaps to post sixteenth century material which had altered the alchemical format as is apparent in the number of colours in the alchemical process, but surely not to the work of Valentine.

The second category of approaches is that of semantics. Applied here, this studies the problem of interpretation of the meanings of alchemical language. We can include metaphors which can be viewed as devices for the transfer of meaning between different disciplines, or alchemy and the general culture.

Naturally this problem occurred each time alchemy was transplanted from one language and culture to another, for the possibility of misunderstanding the aims of previous authors would be feasible.

A classic example is proposed by Hopkins, who discussed the "Colour theory" within alchemy. He argues that for the alexandrian alchemists the meaning of the word "gold" was "any gold-coloured metal alloy or bronze," (A.J. Hopkins, Child of Greek Philosophy 1934). He further states that by the time alchemy reached the Arabs the definition of gold had changed and therefore the ancient recipes for making "gold" lost their meaning and validity. In the first place the Egyptian language lacked a special word for gold, denoting it by the expression "yellow metal" which can apply to any yellow metal or alloy. The term "gold" changed when it was taken over from the Egyptian craftsmen by the Alexandrian alchemists who were deeply influenced by philosophical and religious ideas. The Alexandrians viewed gold not as a substance but as a quality. Equally what the Medieval alchemists viewed as the term "gold" was not that of the Alexandrians as specific physical properties belonging to gold were then recognised.

Naturally Hopkins viewed alchemy from a historical perspective and we know that Gerber and Avicenna had recognized gold by seven physical and chemical tests: fusion, the touch-stone, density, taste, action of fire, solution and sublimation (see Berthelot, vol. I). An Arabic manual of the thirteenth century recognized even more empirical tests. What is apparent is the need for care in interpreting any term in the context of the period the material was written.

The third category to consider is the rhetorical approach. In its widest sense the study of the way

(continued on page 8)



# A Call To Service

by Kevin Townley

In lesson 2 of Fundamentals of Esoterics, we address the paths of involution and evolution. According to this lesson there is a line of demarcation where the aspirant shifts their consciousness from a place of self service, to the service of the One **Self**.

As the person of Jesus felt separated, and abandoned upon the cross, so we as aspirants go through periods of feeling abandoned from the oneness of God. At some point during this experience we have a shift where we know that at no time was there any separation, just the appearance of separation.

The world is filled with many organizations based on the materialist paradigm. This way of thinking is based on the feeling of separation from the One and self service.

Service takes on many forms and often goes undetected.

The LPN is an organization that is dedicated to the unfoldment of the individual, so that they may enter into that state of consciousness that is based on service to the One.

There have been many individuals who have come forward in an attempt to fortify the LPN, so that it may be a strong viable organization that can meet the needs of those who look for such a shift in consciousness.

Through the study of Qabalah, and Alchemy an environment is set up within the personal vehicle of each individual so that a shift can take place, or support the shift after it has taken place. By supplying Qabalistic meditations, and Alchemical experiments,

along with a group of brothers and sisters of like mind, the LPN is able to serve the needs of the individual as well as the service to the ONE.

There are many tasks that need to be accomplished by the LPN as an organization. Our first and primary commitment is to the translation of the French lessons and make them available to the English speaking world. This particular leg of our task is moving along. We now have five of the seven years of laboratory lessons available to our members. The sixth year is near completion.

Besides the seven years of Alchemy, there are also the seven years of Qabalistic study. There is also the course of Fundamentals of Esoterics which has been well received by our members. This brings us to a total of 96 lessons translated to date.

The work is continuing. The commitment to service by the LPN, to those on the **Path of Return**, has just begun. We look forward to bringing to our members, new works never before available in english. Such works include **The Abode of the Philosophers**, by Fulcanelli, **The Collected Works of Eræneus Philithies**, and a brand new Qabalistic text on the Cube of Space. We also look forward to holding workshops, lectures and other meetings that will enhance the sense of group harmony. This work takes time, money, commitment, and the patience of those in charge of these projects, as well as the patience of our members.

We have received some strong criticism from a couple members who feel that we are not doing enough in bringing the Alchemical paradigm to our members. It is indeed foolish to cast away seeds just because they do not have the appearance of the fruit.



(continued on page 8)

## SERVICE

(Continued from page 7)

In the name of **SERVICE** the LPN calls forth all who wish to assist in this work. If there is a suggestion, complaint, a desire to organize workshops, lectures etc., please be bold and offer your service.

It is one of the policies of the LPN, not to place one member over another. Whether a member is in an administrative position, instructor at a workshop, offers to answer questions on Alchemy, or brings in a multitude of members, they must do so in the name of service. If it is not done in the name of **Service to the ONE**, than we ask you not to take on the task.

If you are looking for mass recognition for your efforts, you must look elsewhere. Sometimes those who enter into service do so for the wrong reason. Sometimes ego's get bruised. We are in the business of serving the path of evolution, not the path of selfish serving.

Those who know themselves to be servers of the light, will find this an appealing call. Those who are not will be angry and perhaps destructive.

We look forward to hearing from our members. We wish to work in harmony with all members in the service to the **ONE INEFFABLE GOD**, within Whom, we live move, and have our being.



## DILEMMAS

(Continued from page 6)

in which language is used in argument, i.e. the use of language as opposed to its meaning. Unfortunately, although claims are made that alchemy was an oral tradition, and assuming these claims to be valid, there is no records of any oral debates on alchemy.

In contrast to this however, there exists the view put forward by Fulcanelli which is likely to yield more fruit. He refers to phonetic laws where no attention is paid to spelling - sound and meaning is paramount. Fulcanelli refers to this as argot or cant, and relates it to the **LANGUAGE OF THE BIRDS**, which he states is the language "the one spoken by philosophers and diplomats." Aside from cant, Fulcanelli says strains of the secret language remains today in the dialects of the Romanies and of Picard and Provencal. There is evidence of alchemical material produced by the Romanies so such a linguistic decipherment is feasible. Some claim Rabelais' work to be alchemical.

What can we conclude as to how to tackle material in the future? Firstly, the knowledge of alchemy was not intended for casual readers. The authors of the tracts were educated men and influenced by the society they lived in. Hence material should be interpreted in context of the period of history. Secondly, few alchemical authors wrote from personal experience because of the problems raised in this essay. Thirdly, alchemical literature contains many misleading or false statements, produced either on purpose to protect the author or due to semantic problems. This needs careful examination. Fourthly, and more importantly, any practical craft cannot be learnt merely from books. To understand alchemy, you must perform experiments.

In conclusion, I wish to quote from the Book of Crates (trans. by Berthelot) which sums up the position of alchemy which those with patience and courage will challenge:

"O doubtful names which are like the true names, what errors and anguish have you provoked among men!"

# Jean Debuis Retires As President of LPN-France

*an organizational update by Bill Van Doren*

At the November 1991 annual meeting of the LPN-France Jean Debuis announced his retirement as president of LPN-France. Jean will continue his work in three areas of research:

1. Subtle energies & crystals
2. The method of Nicolas Flamel
3. The application of electronics to alchemy & esoterics.

He will also write further lessons on the fundamentals of Esoterics series which will provide a comprehensive view of the subtle energies of initiation and the In-visible world. These lessons will specifically deal with the structure of these energies and the laws of their functioning & their use. He will also continue work on the revision of the QBL lessons 58-72 as he is able.

Jean's leaving then is no more than a transfer of the administration duties to others so that he may focus his energies on the research and writing of lessons which is so close to his heart. His stepping down from the presidency was an emotional, significant moment in LPN history, but a move that will in the long run serve the members of LPN well.

Jean's advice for the new president was followed and Marc Gerald Cibard was duly elected. Marc is an extraordinary gifted administrator and will insure the efficiency and effectiveness of the LPN France business office. The administrative offices have now been moved to their new location

at 12, avenue Olliver, 92250 La Garenne Colombes, France.

Professionally Marc is responsible for the scheduling of trains in France & those who have witnessed the efficiency & reliability of the French train system will appreciate the contribution Marc will make to LPN.

All in all, these are exciting and positive changes for LPN and indicate that the teachings will continue to grow and expand for years to come.



## Changes in LPN-USA Administration

In November 1991 Karin DiGiacomo took over the administrative responsibilities for LPN-USA from Kevin Townley. Karin was previously the administrative manager of the Manitou Foundation and is highly qualified in the administration of non-profit organizations. Any questions relating to issues of membership, receipt of lessons, etc. should be addressed to Karin. Questions relating to the laboratory practice of spagyrics or alchemy will be answered by Bill Van Doren or Jean Debuis. Questions relating to Qabala or oratory procedures will be answered by Kevin Townley. Mail to the above should be addressed to the LPN headquarters, address in Boulder. Submissions or questions regarding the newsletter may be addressed to Ken Miller at his address in San Diego (see cover for address); articles may be sent on computer disk (IBM format) in Ascii, wordperfect, or wordstar format.

### Translation Project

Brigitte Donvez has completed translation of the 3rd year mineral course (lessons 25-36) and has completed all but 1 lesson of the 4th year mineral course (#37-48). The 3rd year Qabala course (#25-36) has been translated except for lessons 35 & 36.

We have an ongoing commitment to improve the quality of the appearance of the lessons. Three people have been assisting us in this regard. Anthony House, David Welch, & Clenia Abegg are all involved in this work. Such voluntary efforts are critical to the success of non-profit organizations such as LPN-USA and are deeply appreciated.

# Exercises in Vacuum Fractionation

by Paul Baines

(Ed.'s note: This is the latest in our series on the lab notes of Mr. Baines. He hoped these would help others beginning with the work. Regretfully, he passed away in 1991.)

## Components.

**Boiling flask, 500ml.** This is heated in a water bath when distilling alcohol or other volatile liquid. A few pieces of broken pumice are placed in the flask to prevent bumping and facilitate boiling. Pieces of porcelain should not be used as these will scratch the glass. An alternative method to prevent bumping is to incorporate an air leak tube drawn out to a fine capillary in order to provide a stream of small air bubbles beneath the surface of the liquid.

**Spherical joint, ball and cup.** When used in vacuum systems, they relieve stress which may otherwise cause leakage at the joints. They also give flexibility to complicated assemblies. The joints are held together by a spring clip.

**Vigreux column, lagged.**

**Still head.**

**Thermometer.**

**Liebig condenser.**

**Perkin Intermediate vacuum adapter.** This receiver adapter permits receivers to be changed without breaking the vacuum in the system. An alternative is to use a multilimb adapter allowing the flasks to be rotated in sequence.

**Receivers, 100ml.**

**Safety flask/vacuum reservoir.** This consists of a 1 litre thick

walled filter flask fitted with a ground vacuum stopcock.

**Cold trap.** This device eliminates the entrainment of volatile materials into the pump and condensate may be recovered as required. The apparatus resembles a Drechsel bottle which is immersed in a mixture of acetone and dry ice contained in a Dewar vessel. A cold trap was not used in the experiments to be described.

**Gauge.** In this system a Bourdon gauge was used, graduated in mmHg. Some gauges are graduated in mbar or Torr where

$$1\text{mmHg.} = 1\text{ Torr} \\ = 1.3332\text{ mbar}$$

A mercury manometer, such as an Anschutz manometer may be used in place of a dial gauge.

**Check valve.** This consists of a bleed valve from an aquarium shop which costs only a few pence. It does the job quite well when compared to a needle valve costing L150-00! At one time I tried using a Quickfit vacuum regulator containing mercury which is intended to maintain a steady vacuum in the system. This device is now obsolete as it permits mercury vapor to be drawn through the pump and into the atmosphere. This contrary to current regulations regarding working with mercury metal.

**Pump.** The pump employed in this system is from an OR aspira-

tor unit. Various vacuum pumps are available from lab suppliers, some of them extremely expensive. A cheap vacuum pump may be modified from the compressor pump of an old refrigerator. A filter pump may be used but these can be wasteful of water and the lowest pressure obtainable is that of the vapour pressure of water at the temperature of the water, usually about 15mm.

All flexible connections were made with 8mm bore heavy walled rubber tubing. All ground joints and connections were treated with AP 101 vacuum grease.

## Exercise 1.

The apparatus set up with the Bourdon gauge placed on-line between the receiver adapter and reservoir. The system was exhausted to 150mmHg. The reservoir stopcock was closed to isolate the system from the pump, and the latter was switched off. The system was left for an hour. After this time it was noticed that some small leakage had occurred, but that this should not interfere with the working of the system. A mixture of 100ml pure alcohol and 50ml purified water B.P. was placed in the boiling flask. The vacuum gauge was left in position as it was found that oscillation of the needle occurred when placed on-line between the reservoir and pump.

The system was exhausted to 150mmHg and heat applied to the  
(continued on page 11)



## EXERCISES

(Continued from page 10)

water bath. Some adjustments had to be made to stabilize the fluctuations of vacuum/temperature. A steady boil-over was achieved at 40C/120mmHg (limit of pump). It was therefore not possible to obtain a B.P. of 33.5C at 95mmHg. with the present pump.

80 ml of alcohol was recovered.

### Exercise 2.

The apparatus was assembled as before. This time a Kjeldahl bulb was placed between the boiling flask and Vigreux column. A Drechsel bottle was also placed on line between the receiver adapter and Bourdon gauge. This was to act as a safety trap to prevent any liquid being drawn inadvertently through the gauge. The Drechsel bottle may be immersed in ice water or freezing mixture to act as a secondary condenser. It may also be placed ahead of a cold trap to prevent this latter from plugging up to rapidly. The more expensive cold traps are provided with a draincock for drawing off condensate. Such a system would be useful in recovering highly volatile materials such as are mentioned by Cockran.

The alcohol from Exercise 1, was rectified at the same temperature and pressure as previously. 75ml of pure alcohol was recovered.

## WHERE ARE YOU AT IN YOUR SPAGYRIC OR ALCHEMICAL WORK?

The aim of this questionnaire is to help us evaluate the needs of the membership, so that we may better serve you. We thank you for sending it back as soon as possible after you have completed it. Use the back of this sheet for any additional comments.

### HAVE YOU:

- started any lab work? yes/no
- done the first experiment with the Lemon Balm? yes/no
- distilled or rectified Spirit of wine? yes/no
- if so: which % did you obtain?
- extracted any vegetable tinctures? yes/no
- if so: through maceration yes/no
- with a Soxhlet? yes/no
- and which ones?
- distilled Vegetable Sulfurs? yes/no
- if so: from which plant(s)?
- prepared: -some oil of tartar? yes/no
- the vegetable Ens? yes/no
- some Angel water? yes/no
- Sublimed sal ammoniac? yes/no
- prepared the Kerkring menstruum? yes/no
- calcined plants? yes/no
- leached ashes? yes/no

- crystalized salts? yes/no
- made a vegetable stone or a circulatorum? yes/no
- if so: which method did you use?
- concentrated wine vinegar? yes/no
- if so: by fractionned distillation? yes/no
- by freezing it? yes/no
- made acetates? yes/no
- if so, of copper? yes/no
- of ammonia? yes/no
- of calcium? yes/no
- of antimony? yes/no
- of lead? yes/no
- Radical Vinegar? yes/no
- Mederelius Spirit yes/no
- from which origin? sulfide or carbonate?

Thank you again for completing this survey. Please send it to LPN-USA headquarters at Box 11218, Boulder, Colorado 80301.

### ADDITIONAL COMMENTS:





# The Stone

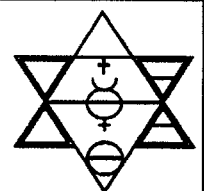

*Journal of Les Philosophes de la Nature - USA*

Issue Number Six

Fall Equinox, 1992

## "Chemist" Alchemists

*an editorial by Ken Miller*

A few years ago I worked at an Oriental Medicine college. Every semester there would be one or two western medical doctors enrolled in the introduction to oriental medicine theory class. These doctors were interested in incorporating the ancient art of acupuncture into their practices. Little did they realize what they would be in for, for their whole view and terminology of the body was going to be turned topsy-turvy! As the instructor began teaching the organ theory in TCM (Traditional Chinese Medicine) these doctors could barely keep themselves composed.

In oriental medicine, terms like "liver" and "heart" describe a whole constellation of processes both physical and mental, and go far beyond our western definitions, including the physical organ, its energy meridian, etc. For example, the teacher related the liver's connection with the emotion of anger, its ruling properties over the tendons, the manifestation of its energy in the eyes, and when liver-fire flared it could cause headaches. These doctors would frantically search their western medical model for correlations to their "liver." Hands shot up asking what SGPT (a liver enzyme) levels would be seen in the patient? Would a biopsy reveal anything? Should a Hepatitis B profile be run? The teacher would smile, shake his head and start again.

The Chinese sought to understand functional activity rather than indications of fixed structural activity. While the Chinese defined their liver through functions associated with it, the western medical doctors defined liver by its physical structure and activities. Thus both had a different view of what liver function was and how its activity could be monitored. So... what does this have to do with alchemy?

I've noticed a tendency in some alchemists to review classical alchemical texts and try to apply modern chemical notation to the older colorful names. In itself, I think this is an interesting idea. But let's not delude ourselves into thinking "this is what the old sages really meant to say." Their world embraced a totally different world view than ours; one that understood notions of how substances were made up of the four elements, etc. Platonic and Aristotelian concepts were as embedded in the culture then as Darwinian and Freudian concepts

(continued on page 19)

### **In This Issue . . .**

Editorial: "Chemist" Alchemists.....Pg. 1 <i>by Ken Miller</i>	
Did They Confect the Philosopher's Stone?.....Pg. 2 <i>by Tim Scott</i>	
Key Problems in Alchemy and the Hermetic Philosophy; Part One: Distinguishing between Spagyrics & Alchemy.....Pg. 4 <i>by V.P.</i>	
A Philosophical Dose of Alchemical Keys with LPN-France.... Pg. 10 <i>by Anthony M. House</i>	
An Argument for the Use of the Original Angelic "Great Table" in Enochian Magic.....Pg. 15 <i>by Jake Davidson</i>	
Esoteric Tourism: From the Bresilienc to the Paimpont Forests.Pg. 18 <i>by A. Bourgeois</i>	
Lab Notes: Spagyrics Month Six..... Pg. 20 <i>by Paul Baines</i>	



**The Stone, Issue Number Six, Fall 1992.** Published twice a year by LPN-USA. Editor: Ken Miller; Circulation: Karin DiGiacomo; Deadline Supervisor: Kevin Townley; Executive Director: Bill Van Doren. Copyright 1992.



# Did They Confect The Philosopher's Stone?

## A report on Twentieth Century testimony.

by Tim Scott

The complete testimony of credible personal experiences with operative alchemy would fit comfortably in a picnic cooler, with plenty of room for your lunch. If you limit the books to 20th Century accounts, the collection will be just about small enough to carry in your pocket. This is not too surprising, perhaps, considering the enormous discipline and difficulty of the Great Work of alchemy. Further, it's easy to understand why someone who had developed a technique to cure disease, give immortality and change common metals into precious would be somewhat reticent about his accomplishments. Accounts of people who have attempted it and failed are just as scarce.

This brings us to an account of a 20th Century American couple who claimed that they had conected the Stone of the Wise, which they even used to resurrect a woman thirty minutes dead.

I have to add immediately that this story is as notable for the questions it leaves unanswered as for the incredible assertions it recounts. I am not attempting to draw a veil of mystery: I simply have been unable to find out any more details. Perhaps someone reading this will be able to provide more information or lead me to a source that will elucidate these mysteries.

I was originally led to the story of the Ingaleses by a side bar in the "Alchemy" article of the occult encyclopedia, Man, Myth and Magic, originally published in 1970. I managed to acquire a reprint of Richard Ingalese's notes for a public lecture he gave on alchemy in 1927; (reprinted in Frater Albertus' "Golden Manuscripts" series). I also acquired a copy of an article on the Ingaleses, which appeared in the Nov. 1928 issue of the Occult Review.

Isabella and Richard Ingalese (born 1862 and 1854, respectively) lived originally in New York City before 1910, where she was occupied full time as a psychic, healer and teacher, and he in the practice of law. In addition, they were also avid students of what was then called "new thought" and wrote a number of books, many of which can still be found in used bookstores today. The two or three I've read contain no mention of alchemy at all and indeed are indistinguishable to me from countless other "metaphysical" books which authors seemed to crank out in the early 1900s: vaporous metaphysical theories with no practical application.

In the Occult Review article, Mrs. Ingalese explained to author Barbara McKenzie how she and her husband became interested in alchemy: "The years after middle life began to draw on, when much reading of works on alchemy left her in grave doubt as to whether the writers were dealing with a spiritual or a practical discovery... Mrs. Ingalese frankly told me that at this time her primary interest in a possible discovery was to stay advancing age and perhaps add another score of working years to man's so-called allotted span." The couple then moved to Los Angeles - I could not discover why - for the express purpose of attempting to create the physical Philosopher's Stone. A suitable house was acquired and a laboratory outfitted, as they pored over the available books and manuscripts to choose a course of action. Everyone who has studied alchemical literature knows it is fraught with blinds, symbolism, hidden meanings, contradictions and omissions. Mrs. Ingalese's psychic gifts proved to be of value as they winnowed the material.

Their original goal was to create the Oil of Gold. But, in Richard's pamphlet describing their work, he wrote, "...gold at \$240 a pound is an expensive thing to experiment with; and, after a while it dawned on us that the principle would be the same if we used copper at 15c a pound. So the experiments were transferred to the cheaper metal." Currently gold is \$350/oz. (\$5600/lb) and copper is about \$1.20/lb. But the purchasing power of \$1.00 has changed dramatically since those days.

After three years of painstaking labor and a steady draining of their financial resources, Mrs. Ingalese produced the first success: the red oil of copper. Richard wrote: "We thought that victory was close at hand, but found it was still some years away. The fifth year gave us the oil of sulphur, but not until we had many fires and explosions and two asphyxiations. The sixth year produced the oil of mercury, the basis of all Alchemy...By this time we had sold all our securities and had two mortgages on our home, but had determined to continue with the work until we met with success, if it took this life and all subsequent ones. But we had all the oils required to make the Stone, and, thus encouraged, we tried to crystallize and fuse them. In 1917 we succeeded in making the White Stone of the Philosophers."

The Ingaleses continued the time-honored tradition of using animals to try new drugs. "We dared not try it on ourselves at first. But there was a third member of our family, a beautiful Angora cat of which we were very fond. We took a vote to see which of the three should test out the Stone, and the cat, neglecting to vote, was elected. It survived the first dose, and we repeated it on the following two days, with the cat becoming more frisky than usual...After that we tried it ourselves, each taking a dose at the same moment so we would exarnate together if it should prove fatal. But it proved beneficial and energized our bodies."

The writer for the Occult Review was less hesitant to sample the Stone. When Mrs. Ingalese asked her if she would care to see and taste the Red Stone she wrote, "I willingly accepted." She then goes on to describe how Mrs. Ingalese "[dipped] a silver knife in the bottle and quickly restoppering it, placed the smear—it was little

## Did They...?

(continued from page two)

more--on my tongue, saying it must lie there and not be swallowed. I immediately noticed an intense bitterness, which is said to be the gold, but other metals I could not detect. In two or three seconds it had been absorbed or dispersed, so that not even a flavour remained in my mouth."

Richard goes on: "Encouraged by this success, we redoubled our efforts to make the Red Stone of the Philosophers, which is the one most mentioned in Alchemical writings. This effort was continuous from 1917 to 1920, when our quest was rewarded."

Apparently, the Ingalese's work was supported in a more than verbal way: After creating and potentizing the Red Stone, Richard writes: "There were several elderly people whom we were under obligations to help in case our search proved successful, and we offered to share the results of our efforts with them; but, being wisely cautious, they preferred to wait until we had tried out the Stone for a year. After that, our renewal club was formed and we all took the magic medicine... Mrs. Ingalese and I have not done as well as some of the other members of the group because of the condition we were in when we commenced the treatment. From 1911 to 1920, [Isabella was then aged 49-58 and Richard 57-66] though having the knowledge and the means to keep our bodies healthful we did not use mind or any medicine in that behalf because, we could not have known what effect the Alchemical products would have on us. From a physiological viewpoint, those were important years in our lives, since our bodies had reached an age when strict attention and care were necessary to prevent quick deterioration. But, even under those conditions, our bodies now attest the power of the Stone, as all who have known us for the last two decades can testify."

As to the Stone's efficacy, Richard makes some interesting observations: "...we tried the stone on many 'incurables.' The number of cases cured was remarkable, but we found it not infallible... We know that the Stone restores virility in men at any age, and normal desire in both sexes. If a woman has recently passed her change of life, it restores all normal functioning of the sex organs. But, if she has long passed that period, then, childbearing is out of the question." Mrs. McKenzie adds: "The cure of a case of cancer, given up by all the doctors, was also claimed. After a few doses the disease was said to be arrested, and after some months' treatment was completely cured."

"I did not verify these statements," notes Mrs. McKenzie, "but record them as given."

Richard also mentions: "...incredible as it may appear, I know of one alchemist more than 600 years old, and one whose age is more than 400, and another whose age is 200, and all of these look and function as do men in the prime of life at about 40 years."

But even this is not as astonishing as his matter-of-fact description of the resuscitation of a dead woman, the wife of a prominent local

physician. "Half an hour had elapsed and her body was growing cold. A dose of the dissolved White Stone was put into the mouth of the corpse without perceptible result. Fifteen minutes later a second dose was administered and the heart commenced to pulsate weakly. Fifteen minutes later a third dose was given and soon the woman opened her eyes. In the course of a few weeks the woman became convalescent, after which she lived seven years."

This is incredibly tantalizing and, prima facie, unbelievable. But what purpose could be served by Ingalese fabricating this story? Surely there must be some corroborating material somewhere. A whole host of other questions suggest themselves: What did the woman finally die from, and at what age? What caused her to die in the first place? What other techniques (if any) were used to attempt to revive her? Why wasn't the Stone used again in the second place?

Richard ended his pamphlet stating that, even at their advanced ages of 67 and 73, both he and his wife looked and felt young and extremely healthy. "This is our testimony in behalf of Alchemy and the Alchemists, which each person may accept, or reject, according to his conviction, until such time as our bodies, now 67 and 73 years of age, respectively, by their youth and vigor, will compel acceptance of our statements."



### And then...?

I'm afraid I haven't the slightest idea. What happened next? How long did Richard and Isabella live? How did they die? Where did they live? Did anyone else write of them? What happened to their laboratory, their notes, and--for that matter--their store of the White and the Red Stones? Is it possible that there is a cupboard in some old house or building in L.A. containing some vials of a panacea or an elixir of immortality?

What about the other members of the "Renewal Club"? Would it not be enlightening to learn their later histories? What about the multi-centenarian alchemists Richard claimed to know?

(continued on page 21)

# Key Problems in Alchemy and the Hermetic Philosophy

## Part One: Distinguishing between Spagyrics & Alchemy

by V.P.

*(Transcribed from lectures delivered in Spring 1992 in California)*

In alchemy you find many explanations that contribute more to confusion than clarification. What we want to do is explicate terminology so that it is really clarifying and not stupefying.

Lets think in terms that there is a body of knowledge we can call Hermetic. That within this body of knowledge there are techniques and some of the techniques are related to what used to be called "Natural Philosophy." These techniques fall into two broad categories: Alchemical techniques and Spagyric techniques. We will cover the distinctions between hermetics as a whole and alchemical procedures and spagyric procedures.

The body of knowledge and doctrines known as "hermetic" basically includes a comprehensive cosmology and a body of theory and techniques based upon this cosmology. It contains within itself procedures that are astrological, and magical, as well as medicinal etc. So the field of hermetic knowledge or hermetic art and science is quite large. It includes a cosmology, it includes a theory that we might call a theory of physics, being a theory of natural causation. In applying this theory different things come about. There is, for example, hermetic magic; and the tendency for hermetic magic is to be natural and astrological magic, rather than to be ceremonial.

There are also what might be called "hermetic chemistries." These hermetic chemistries can be categorized as either spagyric or alchemical. These terms are often used interchangeably and in establishing the definitions that I am going to establish, I am going to make some distinctions here that are founded upon natural distinctions. Whether I was to apply the word "alchemical" to one side of these distinctions or the other doesn't matter. The point is to remember what the distinctions are. If you want to say, "O.K. I'm going to call what you're calling alchemical 'spagyric' and what you're calling spagyric 'alchemical,'" that's O.K. But, don't go around saying that I'm wrong because I chose to apply one of those tags to one and one to another. The question of right and wrong is whether I am making a legitimate distinction, as opposed to a false distinction and I hope I'll be making a good, well formed distinction.

Another important distinction I want to deal with is the distinction between external and internal. Internal and external are not used that much in Western Alchemy, for a variety of reasons. It is used mostly in Chinese alchemy, but it is an important distinction, and I think it is one that bears some looking at. (The examination of the internal and external distinctions will be the subject of the third article of this series. Ed.)

Now, first of all, Myths of ancient origins aside, the whole of what we might call the Hermetic World View, this hermetic knowledge, seems to be derived from an attempt to create a Stoic/Aristotelian model of the world. I'm saying that for a couple of reasons: First because alchemy has a strong connection with the Aristotelian world view. Aristotle's notion of "Forms" and the theory of the soul as the form of the body ties in closely to the alchemical ideas that evolved into the concepts of soul and sulphur. People who waste their time trying to figure out what these emblematic and hieroglyphic pictures from the fifteenth, sixteenth and seventeenth centuries mean, would be better off spending their time reading Aristotelian physics, and in particular Aristotle's On Generation and Corruption. You can bet that the pre-reformation sages didn't have the prejudice against classicism that post-Paracelsian alchemists do! (The importance of the reformation as contributing to the misunderstanding the older tradition and the position of Paracelsus in that movement is the subject of the second article in this series. Ed.) Once you realize the connection between Aristotelian thinking and alchemy a lot that is very, very puzzling in alchemy becomes very, very lucid.

The reason I include the Stoics, is because the stoics were materialists, though they were not materialists in the modern sense of the word. They were materialists in the old sense. The Stoics believed that the soul was a material substance, and they classified the soul as a fire. That terminology continues down in alchemy, when alchemists are talking about soul and sulphur, they are talking about "fiery" sulphur.

Once this is realized, the possible origins of Alchemy in Hellenistic thinking suddenly make an enormous amount of sense. It is really easy to see how a person who was thinking in Aristotelian terms in a stoic frame of mind would start thinking about the world in terms of what we might call hermetic. They would think in these terms: the spirit is a substance, a material thing that you can extract from the body; and the soul is a material thing, a fire that can be extracted. Thus the type of chemical manipulations that characterize alchemical and spagyrics and its terminology of body, soul and spirit, etc., would evolve quite naturally out of a certain world view.

Second of all, a person with a stoic orientation is not like a Platonist. For example, a Platonist would believe a human being has an immortal soul. Neither a Stoic nor an Aristotelian, it could be argued, believes human beings have an immortal soul. So they would be very interested in the idea of an elixir or substance or something like that, that would be either preserving their bodies in youthfulness or would at least give them the power to preserve the soul. For, while the Stoics did believe that life after death was possible, they believed that

## Key Problems.... (continued from page four)

the soul of the individual, this fire, would eventually disperse and decay just as any other natural body would disperse and decay. Unless you had pursued a suitable discipline while alive to make sure that this soul or fire had realized enough internal integration to maintain itself independently of the body.

The thinking that is present in Medieval and Renaissance alchemy has a lot in common with stoicism and Aristotilianism. People who were strongly influenced by these philosophies would have a very strong motive to work toward a material elixir that would then allow them to preserve either their body or energize their soul in such a way that it would survive bodily death.

So I think much of what we might call the psychological impetus to explore the realms of hermetic thought in spagyrics and alchemy comes mainly from a person who had a Stoic/Aristotelian outlook as opposed to someone who had a more Platonic outlook or even, to a certain extent, a more traditional outlook in the context of ancient religious systems.

Within this body of hermetic knowledge there are procedures. You see all types of what has been called Para Chemical procedures. You'll see people talking about spagyrics and alchemy. I think that there is an essential difference here in these types of procedures; or, we'll put it this way, I think that there are procedures that are characterized by an essential difference and I am going to use the word alchemy to refer to one class of procedures and the word spagyrics to refer to another class of procedures.

Student: IS THERE AN IDENTIFIED HISTORICAL DISTINCTION BETWEEN THESE TWO CLASSES OF THINGS OR HAVE YOU LOOKED AT THE PHENOMENA AND SEEN THAT SOME OF IT FALLS INTO THIS CATEGORY (alchemy) AND SOME FALLS INTO THAT CATEGORY (spagyrics)?

That's difficult to say, I haven't specifically gone back over the literature to see if this is the case. To a certain extent modern teachers, like Albertus, have tended to have that implicit in their thinking and for some reason or another, I picked it up. Looking back at the procedures, I see that they do seem to fall into two functional categories, however, it may be anachronistic to look back and say "O.K. this distinction exists." It may not have been made explicit, but I think in these times it is important to make the distinction clear because it allows people to get a handle on some problems you run into with much of the loose talk you hear in occult circles about spiritual alchemy versus laboratory or physical alchemy, etc. It becomes important in looking at some of the internal practices and in particular realizing that much of what is being talked about in the literature coming from Chinese sources is really linked to internal spagyrics, rather than to internal alchemy. We'll get back to that in a bit... (Third article. Ed)

It is easier to define the types of procedures that I am calling "alchemical," than it is to define the spagyric ones. It's almost like alchemical procedures are a distinct class and spagyrics ones are all others.

First let's talk about what I mean by an alchemical procedure. I define alchemy as the art and science of bringing natural substances to their inherent perfection through natural means.

Now, there are a couple of things in this definition that bear closer examination. What I mean by inherent perfection is this: The alchemists had a notion that nature was teleological. That it wasn't accidental, that there was a purpose behind everything that was going on here, a reason why things were the way they were. They had an idea that natural process is supposed to lead things to perfection. This is one reason why alchemy can be looked at as an art of making gold. Not because alchemists chose to make gold, it wasn't an arbitrary decision. They didn't choose to make gold in the sense of saying, "Well you can use transmutation to prove you have the power..." You read, for example, in a lot of pseudo-alchemical literature now-a-days that "Oh yes, alchemy was just a mystical power that people acquired and then they could change metals from one to another. They could have just as easily turned gold into lead."

This is not correct from the perspective of tradition. The reason alchemical works result in changing lead or (more precisely) base metals into gold, is because gold is looked at as the perfect metal. The reason why gold is looked at as the perfect metal is because it is an incorruptible metal. It is viewed as an immortal metal. Take any other metal and expose it to weather and it will change, decay, rot, tarnish, etc. An excellent example of this is the Spanish treasure ships that have been sunk for three or four hundred years. Go down and look at them and you will find the copper, iron, and even the silver is in a state of decay. The gold is just as bright today as it was the day it went down three, four hundred years ago. In spite of the fact that salt water is one of the most corrosive, naturally occurring substances known to man. So you can see why gold was looked upon as the perfect metal.

Now since, as far as the sages were concerned, nature wished her productions to be perfect and gold was the perfect metal, alchemists ended up making something that was valued by society, not because of its social value but because of its natural value as the perfect metal. Had lead been the perfect metal, alchemists would have ended up making lead and not gold. It turned out that this product (gold), which was not chosen by the alchemists at least as far as they were concerned, also happened to be of great value in human society, at least in the west. The interesting thing is that in China, except for one or two dynasties, it is the silver that has always had a higher value than gold, and was always used in commerce, etc. Well, I won't get into the details of that, but the point is Chinese alchemists were more interested in learning how to make silver because it was more valuable.

Student: DID THEY FIND THEMSELVES MAKING GOLD INSTEAD?

Yes, they supposedly could make gold. And they could also make silver. The same thing exists in the

## Key Problems....

(continued from page five)

West, by taking this elixir to a certain degree of development you can make silver, but to higher degree gold. So it is a humorous story that when the Jesuit missionaries showed up in China, they got people interested in Christianity by these broad hints that, as sages from a foreign culture, they knew how to make all the silver they wanted. Which was true in one sense. They just happened to make it by melting down artifacts and using their slave labor in South America, not by alchemy! You might say that they had mastered the spagyrics of the sword.

In any case, the procedures of alchemy led to the possibility of making gold, because gold is viewed as being the inherent perfection of the mineral kingdom. So the means the alchemists used to bring about this perfection are called alchemical operations. That is why I have stated that alchemy has to do with bringing things to an inherent perfection. The transformations in alchemy are not arbitrary, they are designed to lead natural substances to a perfection that is "natural" to them and not forced upon them from outside. You are brought to a state of natural perfection and it is not an arbitrary state, it is not a "magical" transformation.

That is the reason for the second part of our definition, the idea that it is through "natural means" that this is brought about. You need to distinguish between all of the possible ways of making gold, for if you just leave it at saying that alchemy is an art of making gold, it doesn't tell us which art of making gold! There are other ways of making gold within the magical tradition, for example, that involve any one of several spirits who can supposedly turn copper (or other base metals) into gold through magical means. So obviously simply making gold by any means cannot be the thing that differentiates alchemy from anything else. That is why I have specified that it must be through natural means. The reason for doing this is to avoid what I often call the "magician's fallacy" that you often find in a great deal of modern talk about alchemy. People who have an orientation to magic say that alchemists were just accidentally and unconsciously practicing magic. This attitude claims that the chemical or physical procedure is simply a type of magical ritual, and it is a magical



The Stone

ritual that in essence brings the transmutation about. The endless repetition of these experiments causes these things to occur.

Well, that may be the case. But if that is the case there is no independent art of alchemy. Alchemy becomes a subset of magic. That perspective has this disadvantage: instead of talking about the alchemists as sages and artists we have to talk about them as bimbos and fools. For if they never realized they were unwittingly or unconsciously practicing magic, then the whole notion of the wise person and alchemy as a path of wisdom is wrong. If the person is superstitiously repeating the ritualistic manipulations of chemical substances in the belief that he is extracting sulphur, salt and mercury rather than in the knowledge he is really involved in some sort of magical ritual, then he doesn't know what he is doing. He's not a sage, he's not an artist, he's not a philosopher, he's a fool!

If that were the case, the wisest thing to do in alchemy would be to drop everything and just call on the spirits directly. This would be the sensible thing to do and to hell with alembics and retorts. So that's the other reason I insist on putting in the notion of "natural" into the definition.

We now need to make another distinction here, because when I am saying "natural" we have a tendency to think in modern terms of a juxtaposition of "natural" versus "supernatural." And while our modern distinction of natural vs. supernatural goes back to ancient distinctions, when they talked about natural versus supernatural they weren't talking in the same way we are today. We tend to think of something natural as following strict laws of causation and supernatural as willful and capricious, something that cannot be explained. When they spoke of natural versus supernatural they said natural things were subject to the laws of regeneration and decay. Natural things came to be and then passed away. Supernatural things were beyond the laws of generation and had what we might call "endless duration." This becomes important, because what is happening in an alchemical process is a type of regeneration. It is a regeneration going beyond birth and decay to a supernatural state, which means free of decay or a state of immortality. That's not the same thing as the more modern notion of natural as being subject to the lawful rule and supernatural being capricious and willful and not subject to lawful rule.

I want to make it clear that when I'm saying natural I'm using it in the sense of consisting of natural procedures on natural substances. The processes of alchemy supposedly mirror and refine the processes which nature herself uses in the creation of metals "in the bowels of the earth" to use the quaint old terminology. These procedures are of course natural in our other sense of being governed by laws, but it is important to realize that natural substances and their proper natural manipulation is necessary to the success of the alchemical procedure (but it may not be sufficient by itself). According to tradition you could not take any substance and treat it anyway and transmute it into gold (like the fairy tale of spinning straw into gold, etc.). If that were possible it probably would be a magical procedure, and although it might be a spagyric one it would definitely not be an



## Key Problems....

(continued from page six)

alchemical one.

The reason I have belabored this point is to forestall the modern magician saying to me "But magic is natural there is nothing supernatural about it. So why couldn't it be one of the natural means that fit into your definition?" The reason should now be clear. Our modern magician is using natural in the sense of having lawful causal rules and supernatural as defying explanation. We quite agree with him and in fact there maybe purely magical procedures or even procedures combining natural magic with spagyrics that could perform a transmutation, but they would not be Alchemy because they did not mirror the processes of nature as envisioned by Hermetic Physics.

The process of alchemical regeneration, of going from a natural state to a supernatural state is done through lawful procedures. The procedure of alchemy has a quality of lawfulness. Even the preservation of health through elixirs, or preservation of the body, is viewed as a natural possibility. To them the difference was not between lawful versus capricious, it was between mortal versus immortal. That was the distinction between natural and supernatural. The reason I have said this is because in alchemy there is a process of regeneration. This is in part what distinguishes alchemical procedures from spagyric procedures. The notion is that there is a natural process and this process is tied in with generation and the possibility of regeneration.

The best way to think about the difference between an alchemical process and a spagyric process is that an alchemical process is like taking the seed of a plant, and planting it, watering it, tending it and having it grow. Over and over again in alchemical literature they talk about just setting things up and then tending it correctly. All talk about grinding and distilling and all this type of stuff is done by the philosophical mercury within the alchemical vessel. The person who sets about to do that (Grinding, distilling, calcining, etc.), imagining that it is the alchemist himself who has to do it, has gone far astray. He may be an accomplished spagyricist but has missed the royal road to alchemy.

Spagyric procedures are like taking that seed, grinding it up, and using it to make bread. By grinding it up you have destroyed its generative powers. You cannot take a ground up seed and plant it and get wheat from it. You can't take bread and plant it and get anything but mold from it. You certainly can't get wheat from it!

So the whole idea in alchemy is very similar to the idea of planting a seed and tending it. It is a matter of knowing husbandry and not chemistry. Realizing what you might call the equivalent of metallic husbandry. Another reason I brought up the distinction between natural and supernatural is to realize that in alchemy it is a process of regeneration, not generation. Of course there is an inherent process of generation that occurs when you plant a seed and it turns into a plant, which in turn

goes to seed in an eternal process of generation, degeneration, etc.

In alchemy it is as if you could take a seed and plant it and grow an immortal plant, rather than sprouting a plant, that in turn goes to seed to sprout other plants, etc. It is important to realize what the alchemical process has in common with natural generation. It is a process that once started will follow its own rules for development, and the alchemical artist needs only to know how to husband and further this self development; as opposed to constantly interfering with it, trying to make something out of it that was not intended by nature.

However, it is also necessary to realized where this process differs from ordinary generation, for the result of this regeneration is a supernatural being, an immortal being. Just as gold is viewed as being the most supernatural of the natural metals because of its own immortality (due to the fact it does not naturally decay).

If we go back to the analogy that spagyrics is the grinding of the seed into flour to make bread, this should clue you into something. In an alchemical procedure you end up with something that is very closely related to what you started with. It is a perfect plant, it is a perfect metal. In a spagyric procedure you may start out with the seeds of a particular plant and end up with bread; you don't necessarily have your end result directly related to what you started with. You had to take that seed as a starting point because of certain useful properties: It may be that it adds nutritional value to the bread or, as is true of certain types of wheat, that they have enough gluten to make a good bread, where as in others maybe certain types of grain just make a good tasting bread, etc.

Bear in mind that the essence of a spagyric procedure is that you are taking natural substances, extracting from them their useful properties through procedures that are largely what we call chemical manipulations.

In the alchemical procedures, in order for it to be truly alchemical, you are doing the equivalent of planting a seed, watering it, and watching it grow. What you end up with is a perfection of what you started with. Whereas what you end up with in a spagyric procedure may be only distantly related to it, and may have changed its properties very much! Your end "product" may be the result of extracting from your starting point only one property that you were particularly interested in.

Student: FOR EXAMPLE, LET'S SAY WE TAKE A PLANT LIKE ROSEMARY AND SUBJECT IT TO SPAGYRIC PROCEDURES AND CREATE AN ELIXIR OR MAGISTRY OF ROSEMARY. YOU'VE PURIFIED AND RECOMBINED THE BODY, SOUL, AND SPIRIT. YOU CERTAINLY DON'T HAVE THAT PLANT ANYMORE, BUT YOU HAVE A POTENTIZED MEDICINE. IS THIS SIMILAR TO TAKING THE SEED AND TURNING IT INTO BREAD?

Yes

Part of the conclusion here is that if you were really making a genuine alchemical preparation in the plant world, you might not end out with a plant stone

## Key Problems....

(continued from page seven)

at all, you might end up with a type of plant that would be immortal, a perfect plant. A spagyric procedure, such as you describe, would reduce the plant to the mineral kingdom and then reconstruct it on that level, it might be a very useful thing to have but is it a living thing? Was the alcohol or vinegar a true generative spirit of the plant or merely a menstrum that allowed the extraction of certain virtues from its body? Did you truly regenerate the plant or merely kill it and manipulate its corpse in a certain fashion?

Another distinction that could be made is that there is no alchemical procedure that does not include the use of the "philosopher's fire." You must have that as a starting point. Alchemical procedures always and invariably must have, maintain, and remain within the realm of using it; for if they depart from the "fire" they kill the generative spirit. The vulgar fire, ordinary heat, is external to the alchemical process and provides only an external stimulant.

Spagyric procedures do not necessarily have this alchemical or philosopher's fire. They use the vulgar fire or common fire, the fire of the hearth and may use only that, though some spagyric procedures could use the philosophical fire. The distinction here is that while a spagyric procedure might use the philosopher's fire, it doesn't necessarily stay within that realm. For example, since the philosopher's fire is a menstrum, a solvent, you could use the philosopher's fire to extract the soul of gold. You would then have a very powerful extract with which you could use as a spagyric medicine. That would be the use of this fire in a spagyric reagent. So, again, we have a limiting factor: for an alchemical operation to be successful at all it must start, work through, and finish itself with the philosopher's fire, and only the philosopher's fire. External fire (vulgar fire) is only used as an adjunct.

Student: PLANT MAGISTERIES ARE A GOOD EXAMPLE OF THE SPAGYRIC APPROACH. WHAT'S AN EXAMPLE OF A STRICTLY ALCHEMICAL PROCEDURE?

Well, in the plant kingdom the alchemical procedure might be palingenesis, while internal alchemy or those aspects of the homunculus literature that are not purely allegories might constitute the alchemy of the animal kingdom. However all of that is very obscure and the easiest example (if it can be described as easy!) is probably a description of what is called "The Great Work," or metallic alchemy.

However, if you look at the great work you discern that it involves three different sub works. The first is the preparation of this fire. If you have no fire, no alchemy. To a great extent the preparation of the fire is a spagyric work. However, to call it "the preparation of the fire" is a bit misleading. Because in one sense you are not preparing it, so much as extracting it from the air. I can't elaborate on that to a great extent right now, but basically that is what you are doing. You are not so much creating it, as it

is already a naturally occurring phenomena and you are extracting it from the air, which is the philosophical ocean or sea. You are concentrating it and giving it the necessary conditions to become condensed enough to become a concentrated liquid in your alembic. So it is not really a matter of creation, but a matter of extracting, as far as I can tell, from the air.



Once you have this fire there are two other aspects of the alchemical work; the generation of the Sulphur, which is a genuinely "alchemical" work and then the preparation of the elixir. You cannot even begin to generate the sulphur unless you have the fire. If you look at almost all of the works dealing with alchemy they invariably have to do with the second stage. The book that Albertus quotes in *The Alchemists' Handbook* is *The Stone of the Philosophers*. As far as I can figure out, that is largely a discussion of the second stage of the work and cannot be done without the fire. It is the aspect of taking the lead or base metal, exposing it to the Fire, and putting it back into a sealed container. Then put it onto an ordinary heat source just hot enough so the liquid that is mixed with the body, and remember the liquid is the philosopher's fire, just rises and falls in the vessel and by the rising and falling it distills the body, calcines it, grinds it. The body that is in the bottom of the retort or the bottom of the hermetic vessel changes or regenerates by the power of the Fire into this so called Sulphur of the Philosophers, sometimes called the Philosophers Stone.

Student: WHAT TEXTS EXPLAIN THIS PROCESS?

Almost any alchemical text you can name deals with the second part of the work. Everyone talks about it. It is explanations of the first work, of creating the fire, that are hard to find; this is one of those things that is most hidden by the "old ones." There are some hints I have found in *The Aesch Mezareph*, oddly enough. There are many relevant things in Basil Valentine's *Triumphant Chariot of Antimony*. There are a couple other ones that refer to it, but it is very guarded. There are some references that kind of hint at it in *An Open Entrance to the closed Palace of the King* by Philalethes. It really is one of the most guarded things they talk about. It is more hinted around than anything else.

In terms of the most explicit texts, it is a more



## Key Problems.... (continued from page 8)

modern text that was printed by P.R.S. The Hermetic Art by Volpierre. That, as far as I can tell, is the most explicit discussion of the philosopher's fire that is now available.

The best outline of this whole procedure, by the way, is Treatise on The Great Art by Pernety, which is why that is one of the most valuable books on alchemy that you can read. So that is an example of an alchemical procedure. It is basically a matter of taking your fire, your raw materials and sealing them in a hermetic vessel and all you do is apply heat; just as you plant a seed, water it, and watch it grow it's the same thing with generating this sulphur. It's a matter taking your philosopher's fire, your raw material, and putting it in a sealed vessel. Then all you do is regulate the vulgar fire, which is on the outside and simply provides an external stimulus that you regulate. And that's all you do.

That is the basic distinction between alchemical and spagyric. And that distinction makes it a lot easier to read the literature and it will also help to bear this in mind in terms of your practice.

Student: WHAT DO YOU DO WITH THE SULPHUR?

The sulphur is the basis for the third part of the alchemical process, which converts it into the Elixir. It is the Elixir that is actually used as the "powder of projection." You cannot do anything in terms of a medicine for human beings or metals with this perfect sulphur. It is a perfect sulphur, but it's no good just as a perfect sulphur. You have to take that and subject it to the third procedure which converts it into substance that is more subtle and penetrating in order for it to be any good. There are dozens of names and terms for this, so lets not get into finger pointing about what to call it. I call it the Elixir, and there are certainly traditional precedents for that. Also note that I do not call the third thing the philosopher's stone. I call the perfected sulphur the philosopher's stone, and that has traditional roots also. The Elixir is the powder of projection, it is what you actually use as a medicine to administer to human beings or as a "medicine of metals" for that is

how the classical alchemists viewed what was going on. It was not an arbitrary process, you were giving these base metals (iron, copper, lead, etc.,) a medicine that brought them to the perfection of gold.

They even tell you to be careful in terms of the dosage, because if you put in too much it will take that metal beyond gold and convert it into the Elixir, which is how you multiply the Elixir. So you must be careful of your dosage, not only with metals, but with human beings also. They also warn that if a person takes too much of this it is likely to be so much of a shock it will kill them, though the consolidation is that the corpse may be incorruptible. Isn't that nice? Well it saves on embalming costs at least.

Student: SO LET ME SEE IF I UNDERSTAND. TO CREATE THE PHILOSOPHER'S FIRE YOU PULL IT FROM THE AIR. YOU EXPOSE IT TO A BASE METAL, AND THAT DISSOLVES IT. YOU DROP THAT IN A HERMETIC VESSEL. YOU PUT IT OVER A FIRE, AND THAT GIVES YOU SOMETHING CALLED THE PHILOSOPHER'S STONE, AND THAT IS TURNED INTO AN ELIXIR.

Yes.

Student: SIMPLE! WE CAN ALL BE IMMORTAL NOW.

That's right.

Student: DOES IT MATTER IF IT'S LEAD OR WHAT?

It helps to be lead in the natural sense. In other words, the minerals of lead rather than the metal lead. You don't go out and buy fishing weights and hope to be able to do anything with it. You have to start with the lead minerals, because once it has been refined it's been killed. It has been spagyrically manipulated, so that its spirit is dead. So, basically when philosophers talk of things being used alchemically, you have to start with the natural mineral ore and not with refined metals. You can make spagyric extracts with refined metals, but you cannot use refined metals as the basis of alchemical procedures. The high temperature of the vulgar fire that these metals are exposed to in the process of refining them, kills them. For all intents and purposes, they are dead because the vulgar fire drives off the vital spirit.

Well, there you have it.



## A Special "Thank You" to Hans Nintzel

The directors and staff at LPN-USA would like to give a special "Thank You" to a special person, Hans Nintzel. Hans has been involved with the organization from the beginning, and has done most of the recruiting for LPN. He is an inspiration to American alchemy, having made available the vast collection of RAMS material in English, and in teaching laboratory alchemy on a regular basis. His generosity and dedication to the Great Work are an example to us all. We deeply appreciate his continued support.

# A Philosophical Dose of Alchemical Keys, With LPN-France

by Anthony M. House

illustrations by Lillian E. Bradford, based upon original drawings by Mr. House

(Ed.'s Note: This article describes much of what occurred at the recent alchemical seminar in Guelph, Canada. At the request of Marc Cibard, President of LPN-France, Mr. House wrote the following article and then sent it to France for editing and approval. Thus, what follows can be considered the "official" report, approved for publication by LPN-France.)

## Preface

There was a profound sense of satisfaction and happiness, once we were formally introduced, as we sat down and reached an opening of dialogue between French only speakers and English only speakers. We worked methodically together on the immediate problem of language. Gilbert Arnold, who we gratefully thank and hold in regard for his efforts, faithfully gave a simultaneous translation to English from the lively French. He generously supplied the French to LPN visitors, which at times took on some very colorful tones, (at least to my ears), to translate objectively.

This in mind, I attempted the task to write a reliable article on the LPN France, French Canadian workshop. The article itself was written by request of LPN President, Marc Cibard.

To give testimony of an event witnessed by oneself is one thing..., to give the same on behalf of all involved reaches many new challenges! With a deadline to complete and have approval to print, it took a monumental effort to meet the obstacles and bring it to you on time for this issue of The Stone. Its dedication is to PHILOSOPHERS OF NATURE, everywhere.

## Introduction

A workshop encounter, organized by two Canadians and LPN members, Brigitte Donvez of Montreal and Gilbert Arnold of Guelph, occurred from May 28 through the 31st. This function was the 1st of two visits - (the second visit will occur in October of this year in Chicago).

Five custodians of the Hermetic Lore, five Philosophers of Nature, visited the Ontario Province of Canada presenting evidence of their great experience with both the tremendously abundant literature - and more importantly with the execution of the practice of alchemy, qabala, and astrology - richly present in the European quarter. And, more particularly, as practiced at the current headquarters of LPN France: 12, Avenue Olivier - 92250 LA GARENNE COLOMBES.

Issue #5 of The Stone (Spring 92) reported a change in the Presidency and administration of LPN France. Marc Gerald Cibard, now officiating, replacing Jean Dubuis. Lucille Gerbaut, liaison between different language speaking countries, Yves Arbez, Vice President, Etienne Cornaille, Treasurer. This is the team which opened up their research findings to our examination.

Secluded lodgings were provided to (25) participants for this occasion. The first day Mr. Cibard introduced Mr. Dubuis to open amenities. There was clearly a reverence from the team, and semiformal ceremony for Jean Dubuis. Jean, though replete with knowledge, proved to be genuinely (very) modest immediately stating his abhorrence for being called master in an unforced manner, displaying a witty persona.

All of their philosophical, illustrative presentations, expertise in particular areas of Alchymia, and meritorious personalities shone out as paradigm beacons at this special event.

## Day One

An assessment of the participants was first sought for to find the level of experience and understanding to be dealt with. Then steps were taken to cover the basics of rectification/distillation of alcohol; extraction of oils from plants by steam/vapor and tinctures by use of a soxhlet; calcination, and the process of solve coagula i.e. of clarifying and enlarging the salt crystals through numerous imbibings and evaporations. The Golden Chain of Homer diagram was discussed in some detail. This is the graph presenting the condensation of energy which is covered most thoroughly in lesson 11 of the spagyric lessons. Jean Dubuis spoke of the perfect spiritual chaos which divides into two imperfect spiritual elements: niter and salt; niter is a positive-active element; salt is a negative-passive element. He also asserted that there are invisible elements of fire and air and the material elements of water and earth. This is a very important relationship, of energy and matter to understand in alchemy. (See fig. 1)

The tree of life diagram (traditional 10 sephiroth) was used throughout the seminar to illustrate the

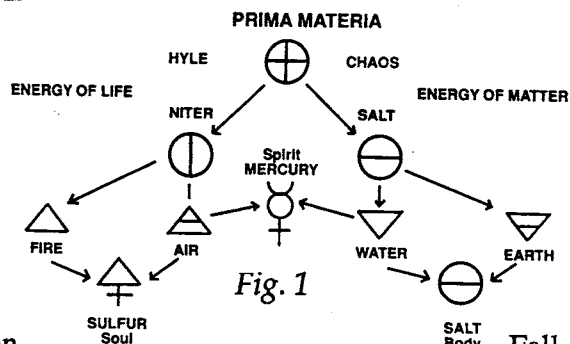

levels and gave dimension were told "contact higher levels of energy." (More on this aspect of dreaming further on).

Mr. Dubuis stated "Making alchemical medicines is only the work of initiation. Qabala, Astrology, Alchemy are all the same;" in the sense of contacting "energies."

Very arresting research, which is covered in lesson 13 of the mineral course, and in the article Spagyrics, by Jean Dubuis (see issue #1 of The Stone), was presented. Isolation of the organic salts of plants - what the ancients called the salt of the sulfur - reveals seven types of salts which correspond to seven types of crystals. This crystallization recognition, proved to be a very keen observation. Studying the angles of the crystalline structure of minerals gives one the ability to direct attention to greater initiatic energies being of predominantly high prevalence in those crystals which are cubical and rhomboidal.

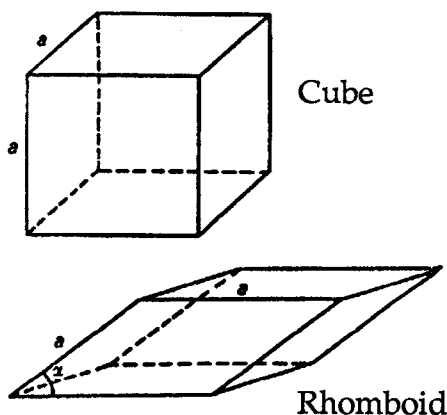

By performing Solve et Coagula in the right spirit, i.e. through mental attention and skillfully handled evaporations, (don't boil the water while evaporating), the sides of crystals become much larger and clearer (transparent). The parameters on the atomic structural levels of the cube and rhomboid give perfect equilateral triangles, therefore these are "perfect" energy conductors. Mr. Dubuis said "Crystal structure can be broken to liberate its (the crystals) energy. This occurs at the atomic level. Melting (fusion) will destroy this atomic crystalline structure."

We were told that Fulcanelli maintained there was no book

named "Abraham the Jew," this is the book which Nicolas Flamel claimed to own, nevertheless, LPN France is in possession of this book.

As a further statement of experience, Jean asserted confidently that the "Animated Mercury in the Flamel process will break the crystalline structure." And, "500 pages of Fulcanelli are not worth 10 pages of Nicolas Flamel."

The book "Abraham the Jew" is printed by Chevalier Denis Molinier his name has the meaning "The Knight of the Fire Stone"

The name Nicolas Flamel has the meaning "Antimony the Flame of God." Nicolas contains "Kohl" by metathesis, which means antimony, and Flamel contains both "flame" and "el" meaning God. We will come to the Flamel process further on in this article.

### Preparation of the Vine President Marc G. Cibard

"Cultivated Grape vines must have their branches trimmed in the winter." The branches are to be calcined to ashes and leached with distilled or rain water, crystallized to salt and exposed to the atmosphere of the night air. From this you obtain an oil. Vacuum distill to obtain "Angel Water" and the salt ( $K_2CO_3$ ). Distill the wine to a honey residue, burn this honey to obtain the salt of the sulfur. For this work we must use a 97% alcohol. A very good way to purify the mercury (alcohol) further is to pour it over the before mentioned salt obtained after distillation of the "oil." Wait until a frost to make this.

Volatile Salts from this process are just as good as Dew!

The distilled salts should be calcined at 200 Centigrade. 4-5 cycles of night air exposure and distillation etc. Eventually, the salts will turn blue. Grind well. With enough salt, it's possible to bring alcohol up to 99.9% These salts will tinct alcohol yellow. This tincture is a medicine. Its use wasn't discussed. (It was presumed no mention of its use was given because of the great caution which has to be observed by us all when it comes to prescription of medicines without a practical license).

## To Capture Fire Energies

Tartar exposed to the night air is known as deliquescent, it pulls atmospheric moisture and gur (pranic energy) into itself, this is the "ENS"...

You may take any dry plant which has been ground to powder (hand grinding is preferable to machine grinding). Pour 3 times volume of ENS over plant. Take this combination and place in an incubator (in the dark) at 38/40 C for 2 weeks. Remove from incubator and pour 97% alcohol over it. After 1 week in incubator, it will pull the energies captured by the ENS. Recoup the alcohol after one week. The color will be from brown to green depending on the type of plant used.

Each plant has major or minor planetary energy influences unique to itself, this depends on whether it's a wild or cultivated plant. There are combinations of the same in the elixirs.

We must mix the ENS with our chosen plant on the corresponding day (planetary) and be sure to use it on the right day as well. Then keep a close watch on your dreams!

This is preliminary work, and there is a great deal of Fire element in these organic preparations, building up to the White Elixirs later on in LPN Lessons. It was stated that initiates tend to have problems with their teeth when these fire energies (consciousness) are contacted.

To review: become adept at rectifying wine and making the ENS.

### Another Method

- continuing the capturing of Fire energies...

Choose a plant and extract with 98% alcohol (from red wine) with a soxhlet extractor. Solve et Coagula - and use Angel Water to charge the salts with Fire.

It was demonstrated how to steam/vapor distill the caraway to obtain its essential oil. On the second day we calcined the extracted seeds in an oven to bring them to ashes. Marc Gerald Cibard showed us that once the caraway seeds had been thoroughly burned to ash (helped by stirring the seeds periodically) that the oven could be

turned off and the embers of the fire would continue on their own calcining unattended. The ashes were leached with distilled water and the water was evaporated off to reveal the crystals on the surface of the glass bowl used for this purpose. The salt was not taken further through Solve et Coagula. Note: lesson 14 of the spagyric lessons covers Solve et Coagula.

When using Caraway seeds 12 lbs will produce 1.5 grams of salt. There are 2 salts that result from Caraway seeds i.e. potassium sulfate and potassium chloride. The left over "soup" (juice of the caraway and water) was not evaporated and ashed to obtain the salt of the sulfur. However, it was believed that we knew how to perform this part of the work. To be sure, there should be the salt of the salt, the salt of the sulfur, the essential oil and spiritus vini for preparation of an elixir or magistry. Imbibing the essential oil on the salts and incubation will give a stone of caraway. Caraway seed and lavender flowers, we were told, once properly prepared will produce initiatic dreams.

Larger transparent crystals are the best. Yellow colored crystals should be omitted from the making of plant stones. Yellow salts can be reworked to produce the larger transparent crystals.

Method: Let the caraway salt crystallize without heat. Take out the clear (transparent) crystals as they crystallize, otherwise the yellow crystals will adhere and tinge them. The crystals grow like tiny tree branches. Caraway salt will absorb oils best 1 hour after sunrise on Wednesday.

As a general rule, all operations of imbibing oils (to make stones) on salts are always best 1 hour after sunrise. The same observed technique applies for the metallic work.

Last crystallization with Angel Water is most important. On this last crystallization of the salt use angel water to charge the salt with fire!

Drosera or Sundew is a counterpart to antimony, a medium between the vegetable and animal influences (kingdoms). Drosera has all seven planetary flows (energies), has little sulfur and salt. Drosera must be very

pure to make into a stone. Within the crystal is all secrets of the alchemical system. From Binah - Saturn the cube crystal will transform its energy, flowing down the sephiroth to Malkuth the symbol of the earth or **ANTIMONY**. NOTE: This is the reason Basil Valentine says antimony has all 7 colors &

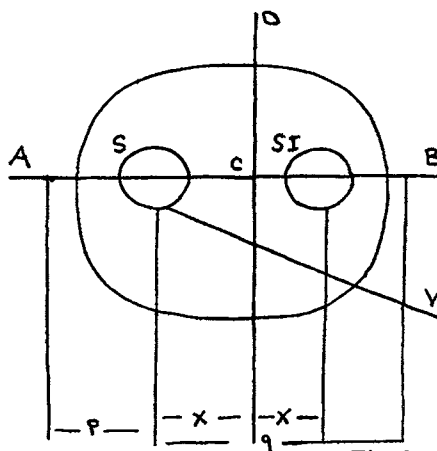

Fig. 2

planetary metals in it.

This chart (fig. 2) is to show the influence of the energy which emanates from S (physical sun) and SI (occult sun) on chart. Occult energy is more pronounced during the summertime. Occult energy lasts only a few days in wintertime. Jean Dubuis made several references to the different levels on the tree of life... "levels 1 and 2 i.e. Kether and Chokmah have no significance for us, it is only in Binah level 3 that there is a direct influence manifesting on the inner levels of our being." The cubical crystal of Binah/Saturn transmits its energy to the other levels below itself.

If you destroy - melt - boil a mineral, thus breaking its crystal structure, the energy returns to its source. **CHALCOPYRITE** - when melted for example, its energy is liberated and returns to Netzach.

## Distilled Vinegar

Note: always use red wine vinegar to obtain radical vinegar (acetic acid), the acetic acid from the supply shops comes from fermentation of wood, wood alcohol and acetic acid effects the optic nerve and can cause blindness.

Fractional distillation of vinegar is a very long method. The best method is by freezing, which

removes the water from the vinegar. We can use plastic jugs or bottles of red wine vinegar which can be purchased from supermarkets.

Take off a fifth of the liquid, and stand bottle up (with cap off) in the freezer. When frozen, the water will mass up in the middle of the jug. Turn the jug over into a funnel, into a beaker. Stop the vinegar flow when the ice mass turns white. Then distill in an oil bath by vacuum 2 times. There will be a residue of honey-like leftover. Dry this leftover very slowly. Some foam will appear if there is any water in it. Solve et Coagula to get the salts, the salts can be incubated, however, there should be a yield of a 30 - 40% acetic acid. This method and more is thoroughly covered in spagyric lesson 33.

The acetic acid (vinegar) obtained varying between 20 - 30%, which is generally sufficient, is used notably for the purification and revivification of metals. And the production of acetates of metals. We briefly went over some aspects of the acetates, skimming over copper carbonate from malachite or its oxide made with the vinegar which gives a blue liquid, add alcohol, distill off the alcohol, add distilled water - place in an incubator - for 2 weeks, agitate daily. Pour this into an evaporation dish, let it slowly evaporate to grow crystals, and blue salts crystallize out. The vapors of this process are very harmful, beware!

Vinegar on oyster shells gives a calcium acetate which yields acetone. Takes 6 months to yield oil. Antimony acetate will be covered in October. Once we get to the fire element at level 8 - Mercury, the outer work is usually done. At this level we may experience problems with our teeth. (Note: Shin or fire is the symbol of a tooth!)



author Anthony M. House & Jean Dubuis

## The Flamel Work

Crude antimony should be picked up from around mines, not bought from lab supply.

### Purification or removal of poisonous sulfuric acid from Stibnite

First separate from the gangue, crush native stibnite, not too much, and run pieces through a sieve to powder. 5 - 10mm - 10 - 20mm sizes is sufficient. Then with a stainless steel tube (see fig. 3):

Fig. 3

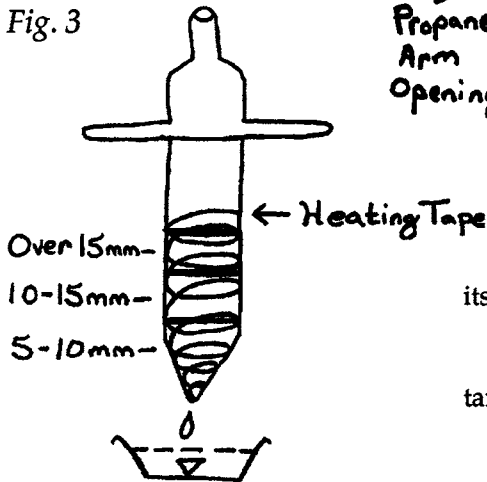

With a 1 cm hole at its base, you fill the tube as shown and wrap heating tape around the closed tube. Below the tube 1 - 2 ft. is a water tub, distilled water or rain water should be used. Once the tape surrounding the tube is heated, reaching (in between) 680 and 720 degrees Centigrade, that is between 1256 F and 1328 F, the stibnite melts and drops to the water below, thus removing the unwanted arsenical sulphurous acid. Refined stibnite is recovered this way, and may be used for our work with amalgams and Regulus.

The next problem is to make Regulus from purified stibnite.

### REGULUS - The Little King

All but a few materials necessary to make amalgams and regulus were brought from France and some was also supplied by Gilbert Arnold. The ovens which were produced very inexpensively gave sufficient stable temperature for the work which was demonstrated (see fig. 4).

The Regulus is a combination of:

The Stone

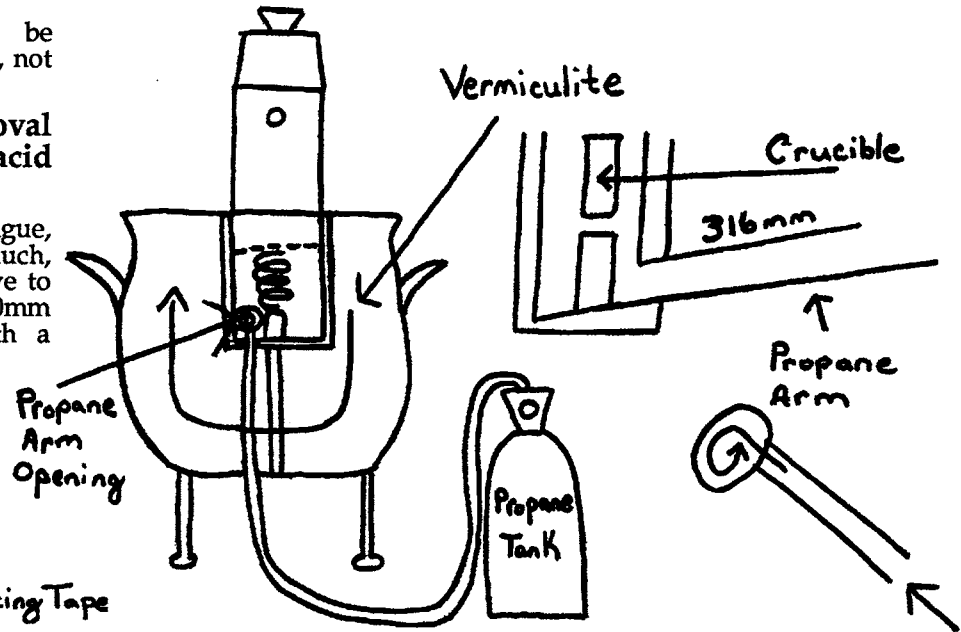

- $Sb_2S_3$  (trisulfide) which has its sulfuric acid removed
- nitre (potassium nitrate)
- tartar (potassium sodium tartrate)
- iron (nails)
- cerrusite

The iron in this process is supplied by tiny iron nails.

When starting out making the Regulus it's best to use potassium sodium tartrate as a fluxing agent, this eliminates explosions which occur when using red tartar as the ancients did. Here it should be noted that the proportions of these ingredients are a factor of many things, and it's a question of the quality of the stibnite used. We were not given the exact proportions, and when asked about them we were told it was a matter of direct experience!



Yves Arbez & Gilbert Arnold

Fig. 4

### STAR REGULE- Martial Stellatus Regule

The method here is not to make an alloy but a solution of iron in the regulus. By adding the above mentioned materials together (the proportions must be carefully tested), into a tall crucible, one spoonful at a time, (note: Jean called this the devil's spoon) the contents of the crucible will melt. Caution: the tartrate has some water in it and can pop or spurt! Never add more of the mixture to the crucible if the surface is boiling. Place the cover over the top of the crucible after each spoonful, and if the regulus mix does not flow, stir the mix with a large iron nail. Add more of the mixture and stir (if necessary) until all of the mixture is melted.

Have a cylindrical stainless steel cone or round cylinder vessel, slightly heated and ready, to pour the fluxed mixture into. Always using gloves, goggles and metal tongs, pour the mixture into the cylinder, and immediately pound the outside of the cylinder to loosen the adherence of the metal and scoria (material covering the refined iron and antimony). Once cool this is then knocked out with a hammer. The scoria (called the crow's head) is removed by light hammer blows, revealing the metal underneath. To break the scoria away is to "Break the crow's head."

Keep the scoria of the first fluxing, this scoria contains the seed of gold. The metal which is obtained from this first fluxing clearly shows its crystallization on its sides. On the second melting, 5 - 10 nails are to be added and melted, along with more nitre on top of the regulus and iron nails, purify the Regulus 3 times with the nitre on top (Caution, sometimes there are slight puffs or even explosions!), when it's poured, break the scoria and recount the nails, this tells if the regulus is hungry for iron. If all of the nails remain unmelted a STAR forms on the surface of the Regulus.

**The Flamel Work** from the text "Abraham the Jew"

### 1ST WORK

Preparation of the Little King or Regulus. Antimony and iron, potassium nitrate, and potassium sodium tartrate.

$Sb_2S_3 + Fe - FeS_2 + Sb$  This symbol .

Iron nails give magnetic life. Three purifications and we obtain the Starry Regulus - add silver and we obtain Star Lunar Regule -> the White Stone -> to this we add copper to obtain Star Lunar Venusian Regule - the Red Stone.

### 2ND WORK

Take Regulus either Starry Lunar or Starry Lunar Venusian Regulus add triple distilled Hg mercury. Prepare amalgam to obtain buttery substance, wash with water until it gets a mirror-like appearance - then distill - to obtain animated Mercury. 7 times = true flights of the eagles. (See diagram below)

Repeat the making of the Regulus amalgam and distill - Fly seven eagles = Mercury Duplex Animated.

Called - "The Dead Doves of

Diana" place in a crucible, the antimony will evaporate and leave silver at 1000 C. Fumes are called the fumes of Saturn.

### 3RD WORK

Seeding to obtain the Elixir. Prepare an amalgam with a Solar Lunar Regulus or Lunar Starry Venusian, native gold and Mercury Animated Duplex - make amalgam, put it in an incubator 40 - 50 days in between 60 - 80 C. LPN France now using 90 C. Little balls of Mercury Animated Duplex become liquid and grow "trees." (See fig. 5)

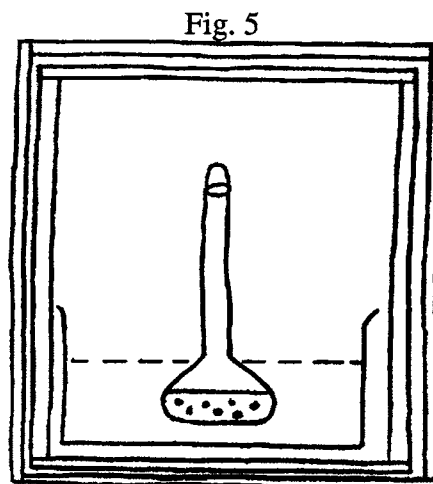

Mercury can turn itself into a red powder. "Sophic Gold" = Red powder.

### MULTIPLICATION

In the flask add Red powder - add animated Mercury and incubate. New powder forms from the Mercury. 70 days at 80 - 90 C. Never fill the flask above 1/3 capacity.

Using Red powder and Mercury Duplex, repeat above process.

With the Red powder, after the third time you will have the Philosopher's Stone. This is a medicine or can be used for transmutation for gold - it is the medicine of the soul.

### ANOTHER WAY

With Animated Mercury and Native Gold method.

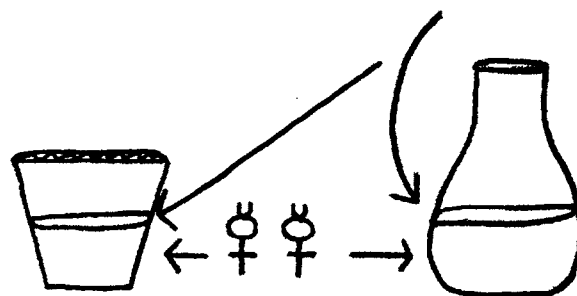

At approximately 370 C. Takes 3 months. This simple procedure produces the same results as the process just described above.

The Flamel Work should be started during Solstice date (left unspoken) plus 3 months.

Needed are "Two Factories"

One to make spiritus vini, and another to make animated Mercury.

The 4 colors of the Work, 1 = wax like, 2 = blue, 3 = yellow, 4 = red.

Always work the mercury when the moon is waxing and ascending, and salts when the moon is waning and descending. (See "Flamel Work" chart, page 22).

*Finis.*

### Hermes Table Comparison

Wind in the belly = Egg(flask)

Moon is the Mercury Duplex

Sun is the Gold

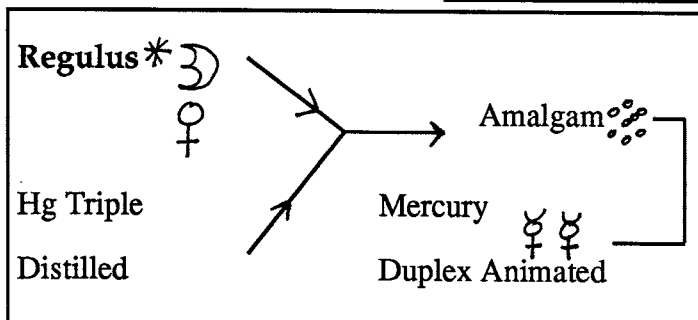

# An Argument for the Use of the Original Angelic "Great Table" in Enochian Magic

By Jake Davidson

## Introduction

Most readers of *The Stone* are familiar, at least to some extent, with the Enochian revelation by the spirits to John Dee and Edward Kelly. The seventh year of LPN kabbalistic studies included Enochian material that have since been withdrawn from circulation. Several books are available, some of dubious merit, others quite informative. And the Golden Dawn incorporated Enochian material, although their source for the material does not seem to be Dee's diaries.[1] However, almost all modern publications base their formulas and illustrations on the Reformed Angelic Table, revealed by Raphael on April 20th, 1587, without considering the context in which this new revelation was received. In this article I hope to present a convincing case that the original table, NOT the reformed, is the better choice for Enochian work.

## The Revelation Begins

John Dee had been dabbling with spirit communication for a while before meeting Kelly; trying to find an accurate clairvoyant with which to communicate with the Other world. He thought he had found a capable seer in Barnabas Saul, and they started working together on about the 21st of December, 1581 (Smith, p.68). This was not a very fruitful relationship as nothing of real value came of it, and revelations of buried treasure proved false. On March 6th, 1582 Saul confessed that "he saw and heard no more of the spirits" (Ibid, p.70). Another source says that "Saul... denied that he had seen anything and proceeded to slander Dee" (Suster p.67).

Two days later, Dee was introduced to Kelly (who called himself Edward Talbot at this time), and on March 10th had their first scrying session; a session that produced "remarkable results" (Smith p.70). Within a few months the revelations we know today as Enochian would begin.

Dee wanted to further his understanding of God and the world around him, and believed that by conversing with Angels he could obtain a deeper philosophical understanding of the universe. This included his desire for alchemical wisdom, and while the spirits made many promises to reveal the formula to make the Philosopher's Stone, it was a promise that was never kept.[2]

## The Revelation & The Interference

On May 28th, 1583 a female spirit named Madini appears before Dee and Kelly. Later her name will be corrected to Madimi, and she along with a male spirit Nalvage will be the principal figures through which the bulk of what we call the Enochian material is revealed. She appears to Kelly as a "Spiritual creature, like a pretty girl of 7 or 9 years of age, attired on her head with her hair rowled up before, and hanging down very long behind, with a gown of Sey, ...changeable green and red, and with a train"(Casaubon, p.1). She proceeded to play among the stacks of books in the library and at first is quite shy. Gradually she becomes more talkative and introduces them to several other spirits.

Conversing with these spirits is not without difficulty, and there are several times when evil spirits interfere with the messages. Nalvage reports that "there is a continual fight between us and Satan, wherein we vanquish by patience. This is not spoken without cause. For as the Devil is the father of Carping so doth he utterly infect the Seer's imagination [3], mingling unperfect forms with my utterance." (Suster, p.71) In other words, Satan modifies the vision and tries to mess up the communication.

The question of deceptive spirits is an important one, for Dee is a very religious man and does not want to be lead astray from God's righteousness. To this end Kelly asks the spirit Galvah, "How can you persuade me that ye be no deluders?"

Galvah: I will prove it by contrary. The servants of darknesse have their Garments stained: their mouths stinck of blasphemy, and lies, but our Garments are no such, neither do our lips speak any untruth: and therefore we are of God, for whoever is of the truth, is of God.

"Moreover, the Devil is known by his works : for the spirit of God controlleth them, the spirit of God agreeth with us, and useth no controlment against it, therefore it is not Darknesse.

"In one thing thou mayest know us differing from Devils. The wicked spirits always abhor this word Mercy. But it is the Doctrine that we preach in respect towards you, we are not now (then) evil." (Casaubon, p.20) Galvah is instructing Dee to listen to what is being said, to be alert for "blasphemy and lies."

A few months later Dee is confronted by what Kelly calls a "foolish devil." After some fervent prayer a celestial spirit appears and vanquishes the devil, then goes on to say, "The power of God entreteth into the soul of man, and doth visit the Chambers of his understanding: openeth his will with power. The spirits of darknesse are ready for every place, and can deceive, saying, This is of God. Unto these you have listened : and have



sworn it as a Covenant between God and you. But I am come from God: and am entred indeed, and will make you hungry in your foolishnesse, that you may become wise; . . . The Prophets & Apostles have doubted in many things; but because they faithfully believed they were not rejected. Their hope became fruitfull, and they blessed with understanding from above. If so be also, you repent, and be sorry in that you have yielded unto the instruments of wickednesse : and follow on, as they your fathers have done, you shall also become wise : But I say unto you, That which you have consented unto is amisse, and false, worse then error it self. For, where you have tasted anie fruit out of that Doctrine. How poor is the power that hath been long told of in you. You have forgotten your own knowledge, and are become of seers, blinde : such as grope their way. Such end, such begining. For the end hangeth from the begining : and is become a means in it self, to bring all things to passe. But neither the end nor beginning of such things as you have handled hath been perfect, or probable: But a deceit, comprehending the image of falsehood : Yea, much more the traps and snares into wickednesse; which deserveth destruction eternally.

"If this may advise you, Be it so. If these examples and probable arguments be sound, Then necessarily you ought of dutie to be compelled by me : But I have opened my mouth and told you. Be it unto you, according to your disposition" (Casaubon, p.54-55).

The spirit is basically saying a couple of things here. First, that Dee has been receiving some false doctrine. Second, that he should apply his reason to what is being revealed ("you have forgotten your knowledge"). In other words, he needs to think about what is revealed; does it make sense, is it sound?

The interference was a constant component of the spirit communication; the angels would often correct mistakes or tell Dee to discard the previous day's work etc. The following excerpt occurred in April of 1584, and is an example of how the evil spirits would try to disguise themselves.

Dee: "After some short Ejaculations of prayers to God, there appeared a great nasty Dogge : with whom I would have nothing to do, but expect Nalvage. He said, that he was Nalvage. We rebuked him as a Hell-hound. At length he departed, and Nalvage appeared; but brighter then (earlier) to day.

Nal: Have you those things I told you to day?

Dee: We have them in record and minde.

Nal: Read them.

Dee: I did read them.

Kelly: He laughed, ha, ha, ha, etc. a great laughter. He hath also a Table, but seemeth not to be like the former Table of Nalvage. There are ten, or eleven divisions in this Table, as was not in the former Table.

Dee: If thou art Nalvage, proceed in the Doctrine of wisdom, if thou art not Nalvage, depart in the name of Jesus.

Nal: I have free will, and therefore I will be here.

Dee: Now I doubt nothing, but thou art a deceiver." At this point the real Nalvage appears and banishes the deceiver; (Casaubon, P.77)



Dr. John Dee

The Tables and Calls were revealed word by word, sometimes letter by letter, backwards. Dee would often, as he did above, read back to the spirit what he had noted, checking for mistakes. Occasionally the evil spirits would try to corrupt the visions. In the following example Kelly's vision is "dazeled" to make him see the word "I Duigo" instead of "I Doigo."

Dee's note: "The wicked power dazeled so the eyes of E.K. that he could not well discern this O, but staying at it a while concluded it to be an U : which afterward, and by and by, he corrected."

Then the spirit corrected them saying, "Where the most force was, the Devil crept most in. Herein the Devil thought to deceive you."

Dee: "It must then be I Doigo."(Casaubon, p.203)

Despite all this interference, the Enochian revelation was successful. And after Dee had recorded the Tables he asks the Spirit "Ave" if he has it all down correctly.

Dee: As concerning the diversity of certain words in these tables, and those of the portions of the Earth delivered by Nalvage, What say you?

Ave: The Tables be true.

Dee: Is it Aydropl, or Andropl?

Ave: Both names be true, and of one signification. I have delivered you the Tables, so use them." (Casaubon, p.188; July 1584). This is important: Dee has confirmed the accuracy of the Tables. Ave tells him to start applying the knowledge, make use of this material.

### The "Reformed" Table

Five months after Ave confirms the accuracy of the Tables, Dee's spiritual diary takes a break. This was not unusual, as Dee would get involved in other projects or travels and the spirit communication would cease during these periods. So from about January 5th to April 16th 1587, no activity is reported.

However, something very strange happens on April 18th, and will herald the last month of communication with the spirits. Kelly gazes into the "shew-stone" and sees their familiar friend Madimi, but from the start things seem very different.

Dee prays: O God confirm us in thy truth for thine own honour and glory, and suffer us not to be overcome with any temptation, but deliver us from all evil now and ever.

Kelly: There appeared Madimi; . . .but now all the rest (of the spirits who were causing trouble) are gone, and onley Madimi remaineth. Madimi openeth all her apparel, and her self all naked; and sheweth her shame also.

Kelly: Fie on thee, Devil avoid hence with this filthinesse.

Madimi: In the Name of God, why finde you fault with mee?

Dee: Because your yesterdayes doings, and words are provocations to sin, and unmeet for any godly creature to use.

Madimi: What is sin?

Dee: To break the Commandment of God.

Madimi: Set that down, so. If the self-same God give you a new Commandment taking away the former form of sin which he limited by the Law; What remaineth then?" (Casaubon, pt.2, pg.9) Madimi then goes on to tell Dee and Kelly that they need to practice unity among themselves and their wives. Dee thinks that she means for them to look after each other in the "Christian and godly sense." But Kelly thinks otherwise and wants to break off the communication; he tells Dee that she clearly indicated to him that they share their wives sexually. Madimi has also promised exciting new revelation and knowledge to begin once they have carried out her request, including instructions on how to make the Transmuting Powder.

Dee seems struck with wonder lust at the promise for new information. Still, he cannot believe she is asking them to swap wives, so the next day he asks her if she meant "carnal use" or "Spiritual love."

The answer appears to Kelly, written upon a white crucifix:

"My grace is greater than a commandment. For this is my grace: That bliss be granted to mad men. As for the things which have been thus spoken: Either let them be, or today freedom will be restored to you. Amen, I say to you, that if I should say to a man - "Go and butcher your brother," and he would not do so, he would be a son of sin and death. For all things are possible and lawful for superior beings. Nor are shameful things less troublesome (hateful) to them than the faces of whichever mortals.

For thus will it be: The bastard will be joined with the son (which is more absurd). And the East shall be made one with the West, and the South with the North." [4] The meaning is clear: have sex with each other's wife.

Dee and Kelly were horrified, but Dee convinces Kelly that they must comply with God's new wishes.

On April 20th, two days after the above communication "Raphael" reforms the original Tables.

A month later, the communication stops, Dee and Kelly separate (due in part to the distress that the wife swapping caused), and as far as I know (based on the available records) Dee never actually practiced the Enochian system. End of story.

## Conclusion

A lot of material was given to Dee, but he didn't seem interested in applying it. He was always asking the spirits for answers rather than using the system himself. I believe there are no extant records of him doing any experiments with the Calls or Tables.

He specifically asked if the original Tables were accurate. He was told they were indeed accurate and to start using them.

The new naked Madimi behaves in a starkly different way than before. Dee fails to apply the tests that the spirits revealed to him to distinguish evil from good spirits, certainly he did not apply his own knowledge or sound judgment.

Putting this all together in the context of the constant interference, I think there is a good case to reject the so-called reforms made to the Table by "Raphael." Taken in context, I believe this part of the communication was merely more interference; Dee did not recognize it as such because he was hoping that Madimi and her friends would reveal the secrets of the Philosopher's Stone. A lesson for us not to let our thirst for knowledge impair our judgment.

## Endnotes

1. Harley manuscript 6482, published in this country as *A Treatise On Angelic Magic*, edited by Adam Mclean (1989), contains Enochian material. When compared with the original diaries, several errors (probably copying errors) are apparent. The Golden Dawn Enochian material has the identical errors, or may be an accurate copy of this Harley manuscript. It is therefore likely that Mathers used this manuscript rather than the actual diaries. A topic for another article, perhaps!

2. It should be noted that a reason Merc Casaubon published Dee's spiritual diaries in 1657 was to demonstrate that the Spirits could not be trusted, such were the number of broken promises and false prophecies made. The True and Faithful Relation was a polemic against occult activities! Not a textbook to be treasured by the would be magician; Merc must be turning in his grave.

3. The word "imagination" had a different meaning in the Sixteenth century. At that time it was believed that perceptions were of two types: sense & imagination. Sense was the data that your senses reported, imagination was information from images; so memory was considered "imagination" as was the clairvoyant seeing that Kelly performed gazing into the shew-stone during the Enochian communications.

4. The answer given is in Latin, and remains untranslated in Casaubon pt.2, pg.12. Special thanks to Father Joseph Gallagher who provided me with this translation. To my knowledge, this is the first time this quotation has appeared in English.

*(continued on page 19)*

# Esoteric Tourism: From the Bresilienc Forest to the Paimpont Forest

by A. Bourgeois

*(This originally appeared in the April 1986 edition of the French newsletter)*

To all of you, Lovers of Science, who spend days and nights at your retorts, who spend time waiting for the rarest of conjunction, hours meditating on the Sephirah, hear the discreet murmurs which well up from the French countryside, in the unknown land of Brittany.

The great occult adventures of the Knights of the Round Table and the Quest of the Grail written in England by Geoffery de Monmouth<sup>1</sup> and Robert Wace<sup>2</sup>, in Germany by Wolfram Von Eschelbach<sup>3</sup>, in France by Robert de Borron<sup>4</sup> and Chretien de Troyes<sup>5</sup> during the 12th and 13th centuries, assembled later by the 15th century by Thomas Mallory<sup>6</sup>, Sommer, Beguin and Bonnfoy. J. Boulanger<sup>7</sup>, Xavier de Langlias<sup>8</sup>, etc... used by Rabelais<sup>9</sup> Apollinaire<sup>10</sup>, Paul Fort<sup>11</sup>, Jean Cocteau<sup>12</sup>, Aragon<sup>13</sup>, and others, are taking place in the antique forest of Bresiliencie, now called the Paimpont Forest.

Should your vacations by adventure lead you to this beautiful Paimpont Forest, situated between Rennes and Ploermel, you can put your steps into the steps of Gawain, Kay the Seneshal, Mordred, Perceival the Gaul, Lancelot of the Lake, of Tristan, Merlin, Arthur and evoke the subtle evanescences of Guenevier, Viviane, Morgan, Blancheflore, the beautiful Sidonie and Olwen the daughter of the Fisher King.

It is not the intention of my writing to retell these marvelous narratives - years would be necessary to do so in our newsletter - but to indicate the actual locations, sometimes still intact, which are quoted in the texts of the 12th and 13th centuries.

And if you can still be fascinated by a legend, take your backpack, cram yourself in your staggering gas cart, start on the road, rent a room in Paimpont or a neighboring village (Plelan-le-Grand, Saint-Malon-sur-Mer, Neant-sur Yvel, Mauron, Concoret) and be marvelled by the places where faith brought life to the imaginary.

## THE SPRINGWELL OF BARENTON

(You need a guide). Merlin and Vivien met here. Initiates modify time by pouring well water onto the curb of the well, called Merlin's stoop.

## MERLIN'S ROCK

Split into two. Wasn't it the rock where Excalibur was imprisoned and drawn by King Arthur?

## GARDEN OF JOY

(Guide necessary). Location of the rendez-vous where Vivien and Marlin frolicked.

## CASTLE OF COMPER

Where Vivien, daughter of King Dyonas was born.

## LAKE OF DIANA

It is believed that Merlin created there the invisible palace that Vivien requested. Lancelot (of the Lake) was reared there by Vivien, after his father's death, the Sire Ban of Banwick.

## VAL WITHOUT RETURN

This is the narrow and embanked valley where Morgan le Fay, King Arthur's half-sister, kept her lover's prisoner. Lancelot was detained there. Vivien, after she learned from him his secrets of magic, kept Merlin there in a bewitched circle, a genuine invisible citadel.

## FOLLE-PENSEE

A little village where monks used to cure mental cases. But weren't they survivors of the Val without Return, bewitched by the sorcery and philters of Morgan?

## THE MIRROR OF THE FAIRIES

The pond that closes the val without return where the fairies of Concoret met after the procession.

## THE SPRINGWELL OF MAILLECOURTE

(You need a guide). Spring of the creek (Rance) which flows into the Val without Return.

## THE BRIDGE OF THE SECRETS

On the road to Rennes to Ploermel. Where Queen Guenevier and Lancelot of the Lake avowed their passion for each other and exchange their first kiss. (And it is where, we ought to mention, all problems started...).

## THE SPRING OF YOUTH

(You need a guide). Ancient places of baptism. It had the property of restoring youth. Meditation place for the initiates.

## OAK OF PONTIUS

(You need a guide). Location of the ancient castle of Pontius. Heroes of the "adventure of Pontius and the beautiful Sidonie".

## FIELD OF THE TOURNAMENT

(You need a guide). Place of the exploits of Pontius.

## CHURCH OF TREHORENTEUC

A 17th century monument dedicated to God... to the Holy Grail and to the Knights of the Round Table. Do not miss.

The forest has other marvels: its fourteen ponds, the castle of Trecesson, Paimpont the village, the Smiths,

## Tourism...

(continued from page 18)

chapels, megaliths, etc...

A guide will prevent you from engaging in fruitless searches, if your time is precious. I am speaking of someone who knows the forest well. If you decide to go on by yourself, use the survey map, the Michelin guide and the guide "carte chasserresse et mythologique de Broceliande" which you can buy at the coffee shop of the main street in Paimpont.

"There I went questing for marvels  
Marvels I quested but didn't see  
I went dreaming and came back a dreamer  
This dreaming dream holds unto me."  
--Robert Wace

## NOTES

- (1) "Historia Regum Britanniae"  
"Vita Merlini"
- (2) "Roman de Brut"
- (3) "Parzifal"
- (4) "Le roman de L'Estoire du Graal"
- (5) "Perceval le Gallois"  
"Lancelot du Lac" - "Cliget" "Le chevalier a la charette"  
"Le roman de Tristan"
- (6) "Le morte d'Arthur"
- (7) "Les Romans de la Table Ronde"
- (8) "Le Roman du Roi Arthur"
- (9) An anonymous pamphlet of the 16th century staging Gargantua the Giant, Grandgousier, Gargamelle, Merlin and King Arthur which indicated Rabelais to write his "Gargantua and Pantagruel".
- (10) "The rotting magician"
- (11) "Sorcerers"
- (12) "The Knights of the Round Table"
- (13) "Bresilienc"

## "Chemist"...

(continued from page one)

are today. In 1531 Cornelius Agrippa wrote of the Four Elements "...this is the root and foundation of all bodies, natures, virtues and wonderful works; and he which shall know these qualities of the Elements, and their mixtions, shall easily bring to pass such things that are wonderful, and astonishing, and shall be perfect in Magic." And "...without the perfect knowledge whereof we can effect nothing..." Yet how many teachers have you heard address these issues in any depth?

I think it is valuable to relate items from their paradigm to ours, but lets not make the mistake of thinking that, for example, the plant kingdom Mercury means ONLY  $C_2H_5OH$ ; or that the mineral realm Mercury "is really" hydrogen! (See Hurley: Herbal Alchemy, 1977).

A final example will hopefully bring this point home. I was checking an article for a previous issue

of this newsletter, and there was some debate as to whether a particular term was Sal Armeniac or Sal Armoniac; some people said well it must be Armoniac, while the different sets of notes all contained Armeniac. Someone suggested that we simply put the modern chemical notation for it down and end the debate. Sure, we could have done it, but who can say whether that is what the original formula meant? Would we loose aspects and subtleties of meaning just as liver means something very specific in Western medicine, and includes a much broader scope of functions in Eastern medicine?

My warning to the "chemist" alchemists is first to master the manuscripts on their own terms and world-view. Then you will be in a position to attempt an adequate marriage of modern ideas with traditional heritage.

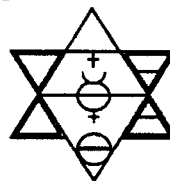

## Enochian Tables

(continued from page 17)

### References Cited

Casaubon, Merc, A True & Faithful Relation of What Passed for many Yeers Between Dr. John Dee and Some Spirits, T. Garthwait: London, 1659. Most recently reprinted by Magical Child in New York and is available through them or Weiser.

James, Geoffrey, The Enochian Evocation of Dr. John Dee, Heptangle Books: New Jersey, 1984.

Smith, Charlotte Fell, John Dee, Constable & Company: London, 1909. A great biography, although hard to find these days.

Suster, Gerald, John Dee: Essential Readings, Thorsons Publishing: London, 1986.

Turner, Robert, Elizabethan Magic, Element Books: Dorset, 1989.

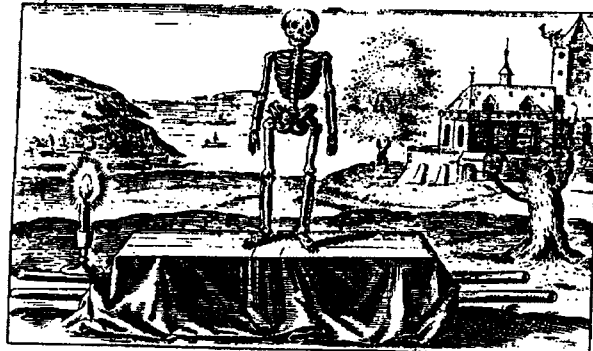

# LAB NOTES: SPAGYRICS MONTH 6

*by Paul Baines*

According to the course material, and 'The Golden Chain of Homer', thunderstorm water contains within it 'Nitre'; this being synonymous with the Sanscrit 'Prana' or vital life force. The first objective in the Work with Water is to collect a sufficient quantity of this water ensuring that this pranic charge is retained. The research work for this month has been to study the nature of thunderstorms, both from a scientific and occult point of view, and to resolve the problems of water collection and charge retention.

There has been little rainfall this summer in our local area; much less than in most other places in the UK. Drought conditions have been declared and water restrictions are in force. Consequently the practical work for this month has not progressed well. There was some rain during one day, during the first week of August and a quantity of rainwater was collected from the roof.

In this, the older part of town, the roofs are of slate rather than tile. The water that was collected was the color of urine and showed a pH of 6. After evaporating a quantity of this water down to a small volume over a steam bath, the result was a dark brown liquid with a pH of 5. The whole batch was discarded.

A further batch of water was collected on August 17, following a total eclipse of the moon. This showed clear after filtration but registered a pH between 7 and 6. A quantity was evaporated to dryness and a brownish deposit was noted. Regardless of this I decided to go ahead and placed a total of 5 liters of the water into two glass sweet jars, the tops being covered with fine cloth. Both jars were placed in the roof space at the top of the house where the temperature of 30C was noted. I am not hopeful of results.

Some pertinent points were put forward by Joseph C. Lisiewski in his article 'The Analytical Technique Applied to the Water Work' appearing in *Essentia* Vol. I Winter 1980. The first point relates to the fact that modern buildings, in fact most buildings today, are grounded by virtue of electrical wiring and plumbing. Thus rainwater collected from such a building would lack the essential charge. To overcome this problem water was collected from a large sheet of plastic with precautions taken to prevent grounding the charge. It is on this reasoning that I have acquired a sheet of heavy gauge polythene 2 X 4 metres in readiness for the next thunderstorm.

The second point Lisiewski makes regards acid rain as has already been demonstrated through my work to date. In order to purify the polluted rainwater a high speed water still was employed. These devices are expensive but probably essential if large volumes of rainwater are to be purified. At present I intend to distill off a couple of litres on a conventional distilling rig for the next task of isolating essential oils by steam distillation. A point of interest is that about 150 years ago an obscure English chemist by the name of Andrew Crosse, of Fyne House, Broomfield, Somerset devised a simple electrolytic apparatus for the purification of water, wines and spirits. Water treated by this method was claimed antiseptic.

"The antiseptic power of electrified water is very remarkable. Not only can it be preserved for years perfectly clear and fresh, but it has the power of restoring the most putrid substances to sweetness. Pieces of meat and the skins of animals in a state of putridity have become immersed in electrified water and in a few hours rendered inodorous. Milk has also been kept sweet for three weeks in the middle of summer, by the application of electricity."

These are experiments I would like to duplicate if I can make up the necessary apparatus. The method may well purify acid rainwater but would its 'antiseptic power' inhibit the production of Guhr. Lisiewski tells us that the use of high speed water stills results in negation of the water's electrical charge, due to their metallic construction and grounded electrical features. I question this last observation as the technical specifications for the Quickfit water stills is that they are of borosilicate glass construction and that no metal parts come into contact with the water or water vapour thereby eliminating the possibility of metal contamination (or grounding the charge in water).

The third stage was the electrification of the water by a means of a Van de Graaff generator supplying a charge of 500,000 volts at 50 microampere for 12 hours. The reason for this was to reintroduce the charge which has apparently been negated during the distillation stage. It is also suggested that this last technique be used to strengthen an existing charge. I would imagine that a lab scale Van de Graaff generator would be an expensive item. In addition I do not know any lab supplies in the UK who would supply such an item. As an alternative a large Wimshurst machine could be used, driven by an electrical motor. I have copies of Wimshurst's original instructions for constructing the machines and would like to make some attempt at doing so.

The idea of recharging water with atmospheric electricity is appealing but dangerous. I have information on devices along much the same lines as a lightning conductor for drawing atmospheric electricity into the lab. Here again I mention Andrew Crosse who did just this and the aerial he used can be seen to this day attached to a high tree in the grounds at Fyne Court. We should remember the unfortunate professor Richman of Petersburg who was killed on the 6th, August 1753, by a discharge of lightning which was drawn through his apparatus in his own laboratory, the charge entering through his head and out through his left foot.



Did Richard and Isabella have any students carry on their work? If so, who were they? Did they publish anything? Frater Albertus, in the introduction to his edition of Richard's pamphlet, loftily states, "We are not greatly concerned here with the individuals known as Richard and Isabella Ingalese nor to their whereabouts up to the nineteen thirties and thereafter." Are we not, indeed, dear Frater? It would seem to me that it would be intensely interesting to a practical alchemist to learn more about two of the incredibly few people who ever explicitly claimed have succeeded in the Great Work.

Ingalese also wrote: "We have never made gold, nor gems. That is a branch that is exceedingly interesting; and when we have the leisure, we shall pursue that part of the art..." Did they ever go on to this phase of the work?

Both Richard in his pamphlet and Isabella in her interview seem to be the model of rational, sensible people. They do not give the impression of being fanatics, charlatans or self-deluded. Mrs. McKenzie writes: "These are big claims, and I was not in the least credulous regarding the matter, for time and direct observation of specific cases alone could justify the statements. But I was impressed by the modesty and care of the statements made by Mrs. Ingalese." In fact, Richard gives several examples of charlatans, con-men and misguided seekers in the course of his talk, and makes the commonsensical observation: "If a person poses as a teacher, ask for some evidence of his knowledge before you enroll as his student...No honest man could object to such requirements." He is referring to alchemical teachers specifically, but certainly this is generally true.

The next question that arises is: precisely how did they work? It is very difficult to find a clear path through the mass of alchemical literature, and teachers were no doubt hard to find in the early 1900s in Southern California. The Ingaleses patiently

read and collected alchemical books and manuscripts for more than a decade, and after a thorough examination of the available alchemical literature, Richard stated, clearly agreeing: "Some one has said, 'You can destroy all other books on alchemy, for their knowledge and more is contained in the alchemical writings of Paracelsus.'" Mrs. Ingalese told the Occult Review's Mrs. McKenzie that A. E. Waite's edition of The Hermetic and Alchemical Writings of Paracelsus were "the volumes that afforded her the most encouragement and help in her subsequent efforts." But as far as specifics go, neither Richard in his pamphlet nor Isabella in her interview vouchsafed any details.

As a woman alchemist, Isabella Ingalese is extremely unusual; in fact none appear in the literature I'm familiar with except as partners or assistants to their husbands. (In fact, a study of these women would be extremely interesting. I mentioned this to my dear wife, proposing the title "Alchemists and their women." She immediately suggested a better title would be "Women and their Alchemists.")

A tangential sidelight: It is interesting to note another 20th Century Alchemist who claimed to have achieved the Magistry. This was Archibald Cockren, who wrote a small book published in London in 1940. The first 120 of its 158 pages were devoted to historical and theoretical overviews of Alchemy. Cockren then describes in a few pages, leaving out large and significant details, his laboratory alchemical work. Nowhere does he mention the Ingaleses, nor is there any indication he was aware of their work, even though the Occult Review article was published in London in 1927. However, there are interesting clues in his writing, which led William Leo, in his 1972 book "Alchemy" to attempt to "fill in this blanks." Cockren's book would, I think, repay a closer analysis and perhaps that could be the subject of a future article.

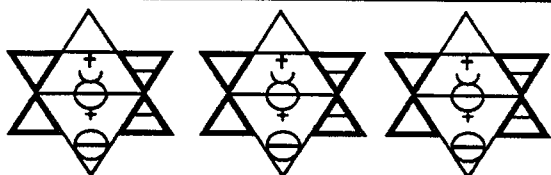

### Tax Deductable Contributions

Your donations to LPN-USA are now tax deductible. We need your help to continue the work; and there is a lot to do. There is material in need of translation, advertising costs, postage, etc. When you give to LPN it is a gift to yourself. We are here to serve you. Give generously, please.

#### IN THE NEXT ISSUE OF THE STONE:

- Letters to the Editor
- Origins & History of Alchemy
- Report on the Chicago Seminar
- Tincture Tartari
- And More...!

## Chart of the Flamel Work (mentioned on page 14)

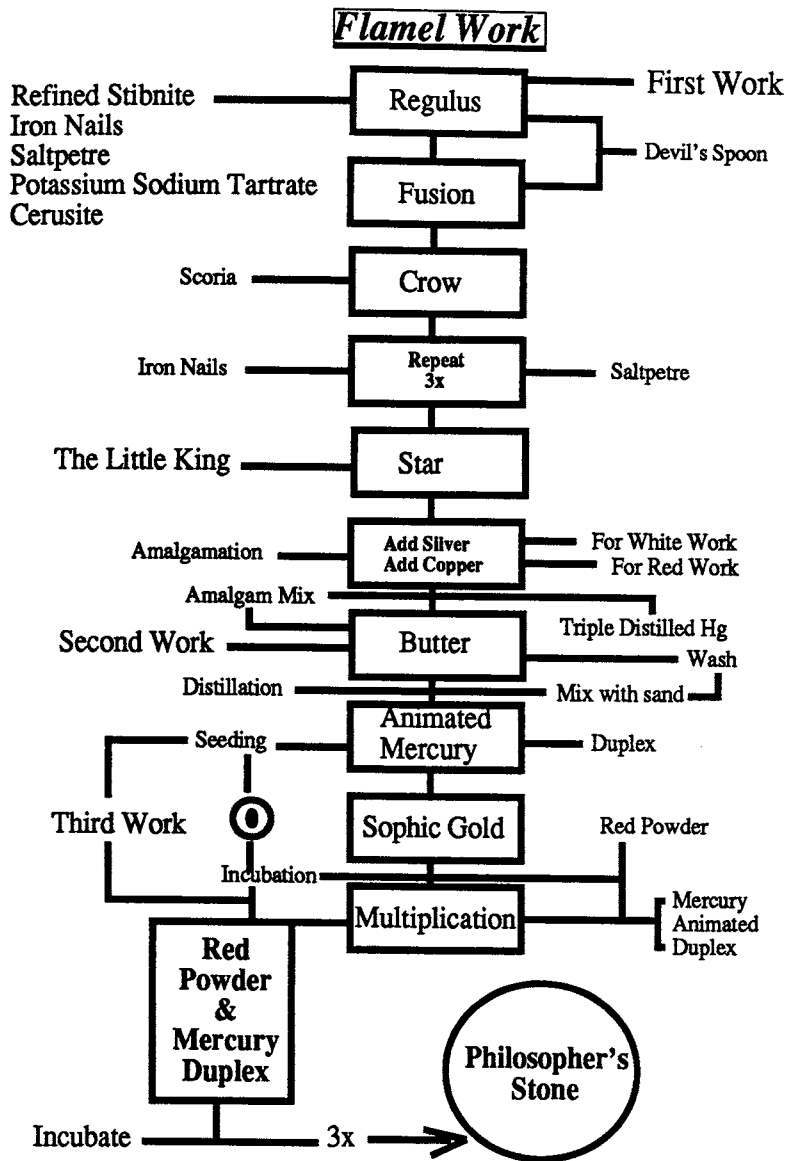

## About The Stone

The Stone is published twice a year, at the equinoxes, primarily for the benefit of the membership of LPN-USA. We hope to get member's feedback regarding what they would like to see in it. Articles, photographs, drawings, letters, and comments from members or others are solicited for submission to the Editor for evaluation. Submissions and advertising should be sent to The Stone c/o Ken Miller, 405 West Washington Street, Suite 314, San Diego, CA. 92103-1996.

## Advertising

The Stone is now accepting advertising, both display and classified ads. Rates are as follows: Full page: \$100; Half page: \$55; Quarter page: \$30; Classified ads are \$0.05 per word. For more information call or write the Editor, Ken Miller, at 405 West Washington Street, Suite 314, San Diego, CA. 92103-1996. 24 hour message line: (619) 491-4500. Calls will be returned collect.

## Subscription to The Stone

The Stone is included in the cost of the lessons. Non-members may subscribe at the rate of \$20 per year. Subscription requests should be sent to the administrative headquarters: LPN-USA, P.O. Box 11218, Boulder, CO. 80301.



Ken Miller, Marc Cibard (President, LPN-France), and Anthony M. House; at the Quelp seminar.







# The Stone



Journal of Les Philosophes de la Nature - USA  
Issue Number Seven Early Spring, 1993

## LPN Seminar April 23rd - 25th featuring Jean Dubuis "Esotericism & Qabala" in Winfield (Chicago), IL.

Do not miss this rare opportunity to study with founder of LPN! Inquire at once!  
Registrations must be completed by **March 30, 1993.**

### Topics:

- How Alchemy and Qabala fit together
  - How to contact the inner worlds
  - Detailed explanations of the worlds of duality
  - Hints on experiences
- \* Your time will be spent half in lecture, half in open forum; so there will be plenty of time to have all your questions answered.

The Seminar is open to LPN members and non-members alike.

Send a self-addressed stamped envelope to:  
Sue and Russ House, 0 South 651 Jefferson St., Winfield, IL. 60190, USA.



Other Upcoming Seminars: A 5-day practical alchemy seminar is tentatively scheduled for October 1993 in Winfield, with the same team as in October 1992. Details will be published in the next issue. The content of the April seminar will lay a foundation for that seminar.

### In This Issue...

Recent Changes in LPN-France provide New Opportunities for LPN-USA; by Bill Van Doren.....Pg. 2

Hermetic Myths & Rosicrucian Fables; (Key Problems in Alchemy and the Hermetic Philosophy, Part Two). by V.P. ....Pg. 4

Who Was Franz Bardon; by Tim Scott .....Pg. 12

Tincture Tartari; by LeFebure .....Pg. 19

An Account of the October 1992 LPN Seminar in Winfield.....Pg. 20  
by Russell House

The Western Yoga Tradition (Taoist Yoga & Alchemy).....Pg. 22  
by P.R. Churcher

Stone of the Wise, by Jim Dery; Corrections to the previous issue of The Stone.....Pg. 25  
and Book Reviews by Ken Miller.....Pg. 26

### Nummi crassities



AS THIS ART IS RARE AMONG MEN,  
SO IT IS RARELY EXHIBITED:  
PRAISED BE GOD FOR EVER WHO  
HAS COMMUNICATED PART OF  
HIS INFINITE POWER TO US HIS MOST  
ABJECT CREATURES.

The Stone, Issue Number Seven, Early Spring 1993.  
Published tri-annually by LPN-USA. Editor: Ken Miller; Cube  
Consultant: Kevin Townley; Executive Director: Bill Van  
Doren. Copyright 1993.

# Recent Changes In LPN-France Provide New Opportunities For LPN-USA.

*by Bill Van Doren*

The first LPN USA workshop was held in Winfield, Illinois on August 30 through October 3, 1992. It provided the attending members of LPN USA an intense and extremely concentrated exposure to the research programs and evolving world view of LPN France. The primary objective of LPN France is to conduct research in Alchemy, Qabala and related studies, and then make known to its membership the results of this research. These research findings are transmitted to the membership in a variety of ways:

1. The theory is presented through the LPN lessons and newsletter. These writings define the developing paradigm and cosmology which arise out of their research, and from the teachings of selected texts.
2. The praxis is also presented through the LPN lessons and articles describing practical lab work and spiritual practices which members may try for themselves.
3. Direct teaching is given through classes and seminars that are conducted by the teaching staff at LPN France whereby attendees can directly interact with those who are conducting the research. The core group of LPN France numbers between 30 - 40 members (out of approximately 950 total members) which are the people responsible for doing the research. They are of course simultaneously doing work on themselves both individually and collectively. The effects of this work on the Self is its own reward and is to some extent transmitted to others whenever direct contact in a teaching environment occurs. This is especially true of Jean Debuis who has been working directly with individual members of LPN France for many years. He extended the same offer to members of LPN USA at the seminar.

To date the relationship of LPN USA to LPN France has been a passive one. The exceptions to this has been the publication of the Stone newsletter. This publication is the means through which LPN members make known their experiences and research in Alchemy, Qabala, etc. There are also plans being made for weekend seminars to be held in Boulder, Colorado and additional seminars in Winfield. This basically passive relationship is one appropriate to the teacher/student relationship. Until all the lessons generated by LPN France are translated into English and made available to at least the Core membership of LPN USA, a passive relationship will remain the appropriate one. In my opinion it is necessary to first study what LPN France has produced and then to test what is offered in the laboratory before presuming that one can function as a contributor to the LPN France research programs.

In one sense, LPN USA is a single member of LPN France as we are provided with a set of lessons in French and in exchange we translate these lessons into English and return a copy to them for their files. This is the arrangement originally agreed upon and will continue to be so until all lessons and newsletters are translated into English. In an effort to complete the lesson translation project as rapidly as possible we are directing all LPN USA funds in excess of what is needed for administration functions into the translations. As of this date the lessons remaining to be translated are Mineral Lessons 61-84 and Qabala Lessons 49-72. It is estimated that our translator Brigitte Donvez can complete this work by 1 July, 1993 provided we raise the funds required to pay for these translations through membership subscriptions or other means. We also need to acquire some office equipment such as a copier and some computer upgrades to make our administrative operations more efficient and cost effective. Once this is accomplished we will be in a position to address the issue of how we are to achieve the transition from passive recipient to that of a peer organization to LPN France. This means one capable of contributing its fair share, both in terms of finances and research.

With the above in mind, I propose that we each begin to consider what it is we would like to see LPN USA become in the future. The range of options is quite extensive and no doubt each individual will come up with an answer which reflects his or her own life goals. In order to make the process a little more manageable I will see to the following:

1. An overview paper will be prepared which outlines the most obvious range of options available to LPN USA. This paper will be sent out to all members.
2. I will solicit from LPN France a statement describing what they perceive to be an equitable and satisfactory relationship with LPN USA. This is quite important as they have not had an opportunity to really express their hopes and expectations in this regard. From their response a second paper will be prepared and set out along with the overview paper. I would appreciate it if each member would study the papers and respond by sending me a letter addressing at least the following two points:

1. Your ideas, desires and hopes as regards to LPN USA. I.E. What if anything you would hope to gain from your association with LPN USA. What if anything you are willing to contribute beyond the

subscribing to the lessons.

2. Describe the form you feel to be appropriate for LPN USA to evolve into over the next few years and give suggestions on how such changes might best be brought about.

It might be useful at this point to consider the position of LPN France. When we first approached Jean Debuis with the plan to translate the Alchemy and Qabala lessons into English in 1986 I had planned to translate all the lessons before making them available through subscriptions. However, by the end of 1987, the grant monies available for the translation project ran out with only 72 of the 216 lessons translated. Thus in March 1988 we decided to set up LPN USA as a membership association with the hope that subscriptions would fund the expense of lesson translations. At that time I felt that we could complete the project in two to three years. At the present it appears the job will not be completed until July 1993, at which time it will have been a little over five years since we began making lessons available and seven years since we initiated the project. It was agreed from the beginning that the French lessons were being provided without cost in exchange for their being translated and being made available. However, it was also agreed that LPN USA would contribute financially to LPN France programs as soon as it was able to do so. To date, except for an original \$500.00 stipend given to pay for expenses of printing and shipping the lessons to the US, there have been no funds sent to LPN France to help pay for the cost of their research programs.

During the October seminar Kevin Townley and I asked Jean Debuis what they felt should be the relationship between LPN France and LPN USA. Jean explained that in the past year or so there had been a great intensification in the research program. Some of the resulting changes were:

1. Jean began to devote full time to research and so turned all administrative responsibilities over to others. Marc G. Cibard is now president and chief administrator.

2. The intensified research program costs exceed revenues from membership income. This means the researchers are in some instances paying out of pocket.

3. LPN France will no longer produce lessons as in the past, but will instead publish a quarterly newsletter which will present the findings of the research projects. These newsletters will be made available for a fee of \$20.00-\$30.00 per issue. We will have the opportunity to translate the newsletter and make it available to our members as well. A portion of the income generated from the sale of this material will go to LPN France.

4. There is an increasing expectation from LPN France that LPN USA will become more of a contributing partner than before. A number of options were considered at this point:

Option A: LPN USA maintains its present passive role and continues to translate and distribute

the published material as it becomes available. In this case we will be expected to contribute financially to the French research to help keep it going.

Option B: LPN USA can participate in the research projects and share the information with LPN France. This of course presumes that the participating members of LPN USA are fully informed of the prior LPN France research and are capable of working at the level of competence of the French researchers. Being fully informed requires that those who participate in such research have in their possession the translated lessons and have become intimately familiar with the theory and practice of LPN France.

Option C: A combination of A and B above.

These were not demands per se, for LPN France has never made any demands on LPN USA in regards to its operating policies nor infringed on its autonomy.

What has been given has always been done with no strings attached. However, it has always been clear that what is being attempted is a very large work and the sooner we can begin to contribute to its successful development the better.

My response was to say that we were bound to complete the translation project first, and as soon as it was completed we would address the issue of how we are to become a net contributor to the overall LPN program of reclaiming Alchemy and Qabala for use in the 21st century and beyond.

In conclusion I believe it is time to begin making plans for the next stage in the evolution of LPN USA and so I hope to hear from those of you who would like to participate in this process so that I can get an idea of what our resources are. For those members who did not attend the Fall seminar I recommend that you purchase the video of the event, produced by member Rick Grimes, so that you can gain an insight into the teaching and teachers of LPN France. The entire program of LPN France is directed toward creating the ways and means by which the individual may access the state of "Initiation". The means to this end are the various teachings in Alchemy, Qabala and related Esoteric studies. I would like to think that LPN USA will soon be in a position to begin contributing in a meaningful way to this process. The choice is yours/ours. Please let me hear from you.



## Tax Deductable Contributions

Your donations to LPN-USA are now tax deductible. We need your help to continue the work; and there is a lot to do. There is material in need of translation, advertising costs, postage, etc. When you give to LPN it is a gift to yourself. We are here to serve you. Give generously, please.



# Hermetic Myths and Rosicrucian Fables

## Key Problems in Alchemy and the Hermetic Philosophy, Part Two.

by V.P.

### The Greek Model

The problem with some of the historical books on alchemy is that they don't tell you anything useful. They don't point you in any direction. One of the long boring books I read quite some time ago, *The Origins of Alchemy in Greco-Roman Egypt* basically spent one very useful chapter explaining Greek influences in alchemy from Aristotelian and Stoic sources and then spent the whole rest of the book explaining mythological fluff from Chaldean and Egyptian sources that was added on in antiquity to give these basically Greek ideas some supposedly ancient origins. The model I am going to give you for the origin of alchemy is a very strong case for the notion that alchemy originated not from ideas that are native to Egypt, but from ideas that are basically Greek, and at a relatively late period.

This Greek model has a great deal going for it, among other things it ties in with modern ideas about scientific discovery. One of the problems you run into with a great deal of alchemical history is that it never explains how people came up with these ideas in the first place. You know the usual "initiated interpretation," supposedly the Hellenistic period learned from the Egyptians and the Egyptians learned from the Sumerians and they learned from the Atlantians. Well, who taught the Atlantians?! You know someone must have figured this out in the first place. Why then place the origins in some remote and untraceable period! Mere Romanticism? There are very strong historical reasons for believing that fundamental ideas that contribute to alchemy had no existence before Plato and Aristotle and the only evidence pointing to proto-alchemical ideas before that period is very weak. For example someone says, "Oh! but the Egyptians had four star gods in the Third Dynasty therefore they knew all about the four elements." Oh yeah, sure! I mean that's incredibly weak. The only place that these things start appearing explicitly is in Greek thinking from the 5 Century B.C.E. onward. In particular, they reached a very high degree of development in the writings of Aristotle and were developed throughout the whole period of 300 B.C.E. to 300 C.E. by people who were strongly influenced by Greek thinking. Greek Philosophy became, we might almost say, the "rage" of the whole Mediterranean basin and there is reason to believe that it went east to India or even further. People really don't realize for example that the silk trade was established as a route from China to the Mediterranean by the 3rd century B.C.E. and was maintained throughout the ancient empire and by the Byzantine empire up to its fall. An excellent example of this type of interplay is the origin of Hindu astrology in Greek practice. So there was a great deal of interplay back and forth between the ancient cultures, some of which we can trace, but much of which has disappeared with the destruction of past records. For example the influence of Nestorian Christian Kingdoms in the area of Turkestan or of the Nestorian Christians in China is hard to trace. The Nestorians were Gnostics and any form of Gnosticism has a strong strain of Platonism running through it.

Now I believe that what we, for lack of a better term at this point, call metallic alchemy, physical alchemy or laboratory alchemy developed in the second or third centuries CE. I believe that it developed because people wanted to demonstrate the microcosm/macrocosm analogy. When I was first thinking about the historical development of alchemy I thought that internal alchemical practices, so called spiritual alchemy or things like that, had developed through imitating processes of physical alchemy. But I now believe that physical alchemy, material alchemy, however you want to call that, and we'll clarify this more as we go along (See part three *Alchemy: Internal and External*, in the next issue, Ed.), developed as a response to meditation practices and the reason why I say that is because you can find traces and roots of these spiritual practices back far further than examples of things that could be used as "chemical texts." Now I don't want anyone telling me about old Egyptian texts on imitating gold! Remember we said that alchemy is not gold making in general (much less gold imitating!), but rather a very specific way of making gold according to a very specific theoretical framework (see part one of this series in *The Stone #6*, Ed.).

### Plato

You can find very interesting fragments in Plato which I call Proto-Tantric, e.g. the idea of the brain as a type of marrow, the strong association between the brain and the spinal column and the sexual fluids, etc. You also see in the Platonic writings the use of Eros as a means of consciousness expansion and thus the two levels, of tantric practice as consciousness expansion and tantra as a physiologic process, are closely linked to sexuality. You see all these things in some of the Platonic dialogues. These ideas and doctrines reappear in the tantric practices of India hundreds of years later and also reappear in the Chinese practices.

STUDENT: Where would the eager hunter find some of these Platonic clues?

The "eager hunter" would find the discussions are strongly relevant to the more physical aspects in Plato's *Timaeus*. They would find the ones that are more related to notions of Eros as consciousness expansion in two

continued on page six...

300 Titles

## Reprints of Rare and Out-of-Print Books

Alchemy Ancient Wisdom Astronomy Baconian Eastern Thought Egyptology Esoteric  
Freemasonry Gnosticism Hermetic Kabbalah Metaphysical Mystery Schools Mystical  
Mythology Occult Philosophy Psychology Pyramids Religions Rosicrucian  
Science Spiritual Symbolism Tarot Theosophy and many more!

✓ Perfect Bound Paperback Reprints ✓ Acid-free paper for long life ✓ Most books with title and author on spines ✓ New titles published weekly  
Trade discounts ✓ Visa and Mastercard accepted ✓ Phone Orders ✓ Fast Service ✓ Full Catalog with complete descriptions available

**Kessinger Publishing, P.O. Box 160, Kila, MT 59920 (406) 756-0167**

All books must be prepaid in US funds. Shipping and Handling Charges: \$3.50 for the first book, add .50 for each additional book.  
Foreign orders multiply total by 15% for surface or 35% for air mail.

- ALBERTUS, FRATER, *Golden Manuscripts*, 160 pages, ISBN 1-56459-303-7, \$16.95  
ANONYMOUS, *Hermetic Triumph and the Ancient War of the Knights*, 220 pages, 1-56459-280-4, \$24.95  
ASHMOLE, ELIAS, *Theatrum Chemicum Britannicum*, 633 pages, ISBN 0-922802-890, \$32.50  
BEGLEY, WALTER, *Biblia Anagramatica*, 212 pages, ISBN 1-56459-016-X, \$9.95  
BEGLEY, WALTER, *Biblia Cabalistica*, 158 pages, ISBN 1-56459-017-8, \$9.95  
BOYLE, ROBERT, *Sceptical Chymist*, 452 pages, ISBN 0-922802-90-4, \$33.00  
CHAMBERS, *Alchemy and the Alchemists*, 64 pages, ISBN 1-56459-005-4, \$9.95  
COCKREN, A., *Alchemy Rediscovered and Restored*, 158 pages, ISBN 1-56459-148-4, \$17.95  
ENCYCLOPEDIA BRITANNIA (1771), *Eighteenth Century Chemistry As it Relates to Alchemy*, 173 pages, ISBN 1-56459-304-5, \$17.95  
FERGUSON, JOHN, *Bibliotheca Chemicæ*, 1085 pages, ISBN 1-56459-001-1, \$50.00  
FIGULUS, BENEDICTUS, *A Golden and Blessed Casket of Nature's Marvels*, 391 pages, ISBN 1-56459-180-8, \$19.95  
GARSTEN, E.J., *Secret Fire*, 120 pages, ISBN 0-922802-20-3, \$17.95  
HAMILTON-JONES, J. W., *Bacstrom's Alchemical Anthology*, 152 pages, ISBN 1-56459-154-9, \$17.95 (not for sale outside of the USA)  
MUIR, M.M. PATTISON, *Story of Alchemy*, 208 pages, ISBN 1-56459-019-4, \$18.95  
PARACELUSUS, THEOPHRASTUS, *Archidoxes of Magic*, 160 pages, ISBN 1-56459-171-9, \$17.95  
PETRUS OF FERRARA BONUS, *New Pearl of Great Price*, 441 pages, ISBN 1-56459-142-5, \$29.95  
PHILALETHES, EIRENAEUS, *Collectanea Chemicæ*, 160 pages, ISBN 0-922802-81-5, \$16.95  
RALEIGH, A.S., *Science of Alchemy*, 172 pages, ISBN 1-56459-007-0, \$16.95  
RALEIGH, A.S., *Speculative Art of Alchemy*, 191 pages, ISBN 1-56459-006-2, \$16.95  
READ, JOHN, *Alchemist in Life, Literature, and Art*, 120 pages, ISBN 1-56459-210-3, \$17.95 (not for sale outside of the USA)  
READ, JOHN, *Prelude to Chemistry*, 328 pages, ISBN 1-56459-015-1, \$24.95 (not for sale outside of the USA)  
READ, JOHN, *Through Alchemy to Chemistry*, 206 pages, ISBN 1-56459-013-5, \$19.95 (not for sale outside of the USA)  
REDGROVE, H. STANLEY, *Alchemy Ancient and Modern*, 141 pages, ISBN 1-56459-143-3, \$17.95  
REGARDIE, ISRAEL, *Philosopher's Stone*, 204 pages, 1-56459-282-0, \$17.95  
RIPLEY, *Compound of Alchemy*, 90 pages, ISBN 1-56459-077-1, \$12.00  
RULANDUS, MARTINUS, *Lexicon of Alchemy*, 466 pages, ISBN 0-922802-92-3, \$30.00  
STOLTZIUS VON STOLTZENBERT, DANIEL, *Little Mystic-Magic Picture Book*, 231 pages, ISBN 1-56459-027-5, \$15.95  
TAYLOR, F. SHERWOOD, *Alchemists, Founders of Modern Chemistry*, 246 pages, ISBN 1-56459-002-X, \$24.95  
VALENTINUS, BASILUS, *Triumphal Chariot of Antimony*, 205 pages, ISBN 1-56459-021-6, \$17.95  
WAITE, ARTHUR EDWARD, *Alchemical Writings of Edward Kelly*, 220 pages, ISBN 1-56459-166-2, \$19.95  
WAITE, ARTHUR EDWARD, *Hermetic and Alchemical Writings of Paracelsus*, 800 pages, ISBN 0-922802-1-81, \$37.95  
WAITE, ARTHUR EDWARD, *Hermetic Museum Restored*, 700 pages, 1-56459-284-7, \$29.95  
WAITE, ARTHUR EDWARD, *Secret Tradition in Alchemy*, 413 pages, ISBN 0-922802-83-1, \$33.00  
WAITE, ARTHUR EDWARD, *Three Famous Alchemists*, 186 pages, ISBN 0-922820-84-X, \$16.95  
WAITE, ARTHUR EDWARD, *Turba Philosophorum*, 211 pages, ISBN 0-922802-99-8, \$14.50

dialogues, the *Phaedrus* and the *Symposium*. There is also a very interesting dialogue, a very suggestive one in particular, for the notions of internal alchemy and its practices: the dialogue *The Statesman*, which is an extremely dull dialogue, but is important because first of all its prime image is that of weaving and the weaver. And curiously enough the ancient etymology of Tantra is closely tied in with weaving and it's very amusing that the so called tantra texts derive their meaning from the notion of weaving.

In the *Statesman* there is a myth about The Golden Age and how during this period the Hand of God turned the world, and when the Hand of God turned the world people appeared out of the earth as old men or women and then grew young and finally disappeared, having first become children and then babies and finally disappearing. In other words, people grew younger instead of older. This is one of the primary images one finds in the practices of Yogic Alchemy in China. One finds the idea that you must reverse the internal heavenly circulation, and it is amazing how easy it is to apply this idea (of the world being turned one way by God and people grow younger and when He lets go the world turns the other way and people grow older) to some sort of internal practice related to rejuvenation and immortality.

In the Platonic dialogues, which were basically written in the 4th century B.C.E., we find a lot of interesting clues which I believe were developed as meditative or internal practices throughout the Hellenistic period. I think for example, they strongly influenced early Christianity and that early Christianity basically had such teachings.

If you take as an example the often repeated saying of Jesus, "What thee sow so shall you reap," it's usually only quoted that far and people of a modern Theosophical persuasion say, "Yeah, Jesus taught belief in the Law of Karma." But they are not repeating the whole of the quote which is, "What thee sow so shall thee reap. He that sowest to the flesh shall reap corruption from the flesh, but he who sowest to the Spirit shall reap life eternal." The whole quote doesn't have much to do with Karma, but seems to encapsulate the basic idea behind meditative or internal alchemical practices. And the fact that it is a direct quote from the "Big Guy" is very important because there are very strong indications of some type of esoteric teaching involved in what he was doing.

In a nutshell you have an important rule in alchemy: Sow to the Spirit and reap eternal life, sow to the flesh and reap corruption. It was a rule that was definitely obeyed by the tantric "alchemists" of India and China and there is a strong indication that internal practice was going on from the 3rd century B.C.E. to the period of the historical Christ, but there is little indication of what we might call laboratory alchemy or gold making before the 2nd or 3rd century C.E. So I believe that meditative practices strongly linked to maintaining the internal generation of power, developed at some

point but it's not clear when. It's not clear whether Plato in his dialogues was simply hinting about practices that he inherited from the Pythagoreans or from the Orphics or who knows where, or some innovations of his own period, or insights of his own. In any case, early explicit sources for many ideas that became very important later on are the dialogues of Plato. Further, there is strong evidence that Plato was influenced by Greek medical texts. While there is strong evidence for an origin of these practices in Plato's time, there are few explicit indications before then.

## Aristotle

In terms of the Hermetic world view, we find that the work of Aristotle is extremely important, since Aristotle was the first person to work out the details of four element theory in a way which was to dominate European thinking for centuries. While Plato may have been discussing practices from other sources, it is generally considered that Aristotle's work is largely original, though strongly based in some presuppositions from the Platonic school.

I suggest that the early alchemists were trying to imitate in the outer world of nature experiences they had in the inner world, and that the internal paradigm they already had achieved was driving their search for an external practice. That a Paradigm could drive the search for the stone is indicated in Philathes' *Open Entrance* (See the chapter "Concerning the Discovery of the Perfect Magistry"). Of course this is only Philathes' model some thousand years after its discovery! Still, that Philathes' thinks in terms of a Paradigm driven research project is very suggestive indeed!

A reason why they might have been driven to find an external elixir could be that the Stoic and Aristotelian philosophical schools do not adhere to the concept of personal immortality; so the notion of preserving the physical body or the very least finding some way of maintaining the integrity of the soul would be important. The Stoic, and possibly even the Pythagorean, (see for example Plato's *Phaedo* for a view of the soul as a harmony which might survive the body's death for a time but would not be immortal,





and is attributed to some Pythagoreans present on Socrates final day), idea about the soul is rather similar to the Chinese idea of a soul in the same sense that they view the soul as breaking up into component parts at or shortly after death. So, the major reason the Chinese do their meditative practices is to make sure the soul maintains its integrity. A similar idea would have been held by the stoics who would have wished that through their practices the soul would maintain its integrity.

I believe that the internal practice provided the paradigm, that this paradigm came together with Greek thinking and it was not at all foreign to Greek thinking. In other words, one of the prejudices we inherit from the 19th century is that Plato and Aristotle are just philosophers, in a very limited and modern academic sense, and could have no possible interest to people who are studying alchemy or other "esoteric disciplines". No one in any of the Mediterranean cultures, including the Arabs, from the Medieval period to the Renaissance, no one would have questioned the relevance of Plato or Aristotle for understanding Alchemical texts. The ground work for this prejudice was laid in the Reformation and we'll be talking about that later.

## Understanding Alchemy in Context

The importance of this history is to provide you with something that is useful, and to come to a realization of how important Greek thinking is. To understand that there probably would have been no metallic alchemy without Greek thinking is to realize that you need to go back to those sources in order to understand the world view in which alchemy developed; because if you do not understand that world view the process and the names and everything else about them are going to be increasingly different and difficult to understand. You are going to find people making all sorts of odd interpretations of them, which is exactly what has happened since the middle of the 19th century. Without fully understanding this world view, you won't be able to really understand how alchemy developed, nor how to proceed in the practice, because you must understand theory before you can proceed to practice.

You do not just stumble upon the Philosopher's Stone. The search is driven by a model whether you realize it or not! Unfortunately most people do not have explicit models to work with and so their models are muddles. Without the right model you are just wandering in the dark. A clear understanding of this model will not be found in those 17th century books of alchemical emblems, with their poetic descriptions. They are hopelessly confusing and will do nothing but lead someone astray, unless one has their meditations on these things firmly grounded in the world view of the time.

And the world view at the time was Platonic and Aristotelian. So, a person who is interested in alchemy, who doesn't familiarize themselves with at least the general outline of Aristotelian thought, and in particular Aristotle's thinking about the physical world, is completely at sea. It is also important to

understand that classical alchemists did not denigrate reason and thinking, and the rational mind as the modern Romanticist and their descendants do. They viewed reasoning as being a divine gift, a divine quality. This is exemplified in the dialogue *The Statesman* and it's basic image of weaving.

Plato envisioned a process of weaving back and forth between intellectual intuition and discursive reasoning. Between intuitive insights, gained through the direct perception of the ideas, and the discursive, logical extrapolation of them. So that even something that was revealed or discovered through a process of logical explanation would be considered a divine revelation, because logic was considered to be a divine faculty. In modern times we've completely lost this perspective on logic for a variety of reasons, some of which we'll deal with in a moment.

The idea that I want to emphasize is that there seems to be proto-alchemical ideas, meditation techniques that related to practices of "seed" retention; meditative processes much like the internal practices of Yoga in both Hindu, Indian Tibetan and Chinese practices. These practices probably arise from a strain of thought that is central to Greek thinking. It is not peripheral, it is not like people just took Greek physics and applied it to the mystical ideas or ideas that we would now call mystical. Mysticism in a very profound sense is a core aspect of Greek philosophy as it existed both in antiquity and up to the 20th century. So it is not like they took "Greek scientific thinking" and misapplied it to irrational fantasies. Within the context of Greek thinking things like alchemy would arise naturally. Once you start considering the notion that physical things each have their qualities from a form, and that form is something that is non-physical, (and this is Aristotelianism), then it is very easy to see that there must be a "form" of gold and it must be possible to take that form of gold and make it manifest and do things with it, etc., etc. This is the reason why it is so important to get into their world view and understand that world view. You realize something like alchemy could and possibly did arise as a natural part of the speculative science of the period and that it is not something that just sprang out of some mythological depths of the collective unconscious.

It is an important perspective to come from because it allows you to go back and look at the material and use it to reconstruct the world view in which these alchemical texts were written. And unfortunately due to events that I'll talk about in a moment, that world view is absolutely foreign to us in the 20th century and so completely forgotten that people don't realize how radically they can misinterpret these texts. The key to understanding that world view is in ancient Greek philosophy. Not in ancient Egyptians or Sumerian mythology but in ancient Greek philosophy, in particular Plato and Aristotle.

Now there is one more point from the middle ages that I want to cover, because it is an important point to one of the major misinterpretations of alchemy, the psychological interpretations, as described by Jung. Let's look at the origin of alchemical emblems, these



complex images or pictures that modern psychologists, particularly Jung, have interpreted as being images spontaneously arising from the collective unconscious. It may be that the unconscious has images like that, but I suspect the actual origin of the use of these complex allegorical pictures is more in the "art of memory." If you read Dame Francis Yates work The Art of Memory and read about the rules by which people made up these memory pictures, one of the rules was you chose images that were likely to be as striking and memorable as possible. I believe the reason why we have these striking images of dragons biting or wolves devouring the sun and such things, is because they are designed primarily as mnemonic devices which would have developed in a particular school to help remember the processes. But, like all mnemonic devices, if you don't have the genuine key you're just wasting your time. The very richness of the imagery is almost to its disadvantage because of the suggestiveness of it. That is why I say people are largely wasting their time working on these emblems and images, because they are not what the artists intended you to do with them because the artists intended them to be memory aides, not meditation objects. If you look at the meditation alchemy in China and other places it certainly doesn't involve those types of images, although some of the internal practices you would find in China and Tibet do, in fact, contain complex images. We'll go into more detail in that later.

## Reformation hides Greek Thinking

The Reformation (i.e. the period of the 1600's) is an extremely important part of the study of alchemy. The world view in which alchemy was formed and propagated over the span of two thousand years (400 BCE. - 1600 CE.), this world view we've been talking about started to be broken down during this period. And again, the value of history is that it provides us with a direction in which we can understand things, and it shows us something of the dynamics. It is during this period of Reformation that Europe underwent enormous changes. These changes had to do with the rise of the modern "scientific world view," changes that also took place in religion, philosophy, and almost every aspect of European culture. For the perspective of alchemy and traditional esoteric arts none of these changes were positive.

The Reformation became not only a reformation of religion, but also of what was called "natural philosophy." What we now refer to as the "scientific revolution" was very much tied into these changes in natural philosophy, and became a polemic in which the different sides, the Protestants and Catholic sides of the Reformation, argued. People don't seem to realize, or they don't pay enough attention to, the fact that the Rosicrucian manifestos were basically manifestos of religious and scientific reformation. They were calls to a complete reformation both in terms of religion and science. They were Lutheran in their religious orientation and proposed combining Alchemy and Qabalah as the means of renovating both natural philosophy and religion. One of the major things that you discover is that to an enormous extent Paracelsus was adopted by Protestant thinkers

and speakers, primarily because of the criticisms which could be leveled against the whole learning of Catholic Europe.

The whole impetus of the Paracelsian movement, from the time that Paracelsus lived through the end of the 17th century, came from Protestant circles. Thus we find, for example, that the so-called Skeptical Chemist, Robert Boyle's work, is considered an important piece of early "objective" scientific writing; as if Boyle was the first person who ever opened his eyes and looked at a chemical experiment before. It is really not so much an objective piece of writing, but a Paracelsian polemic against the Aristotelian chemistry of the period!

The reason why a polemic, a Paracelsian polemic, against Aristotelian chemistry would be very important is due to the Roman Church. At the Council of Trent, (1545-1563), had tried to shore up the Sacrament of the Eucharist by tying it in with the ideas of Aristotelian physics. So it became a matter of great importance for Protestants who wished to argue against the Roman Catholics' position, to disprove the Aristotelian chemistry, and show it to be false in every possible way; thus undermining the whole interpretation of the "miracle" of transubstantiation, which had become an article of Catholic Faith. Undermine Aristotle and you undermined the "papist antichrist!"

The result of this is that as you go through the 17th century, the Hermetic authors of that period move away from or attempt to hide basically Greek aspects of their ideas and inspirations. A major Protestant criticism of the Roman Catholic Church was the fact that the Catholic church intended to be a universal church, (that is what Catholic means), and Catholicism attempted to create a synthesis of Greek ideas and Hebrew ideas in the form of Christian theology. A major complaint of the Protestants was that there was too much "paganism" in Christianity and they wished to get it out. The Protestant thinkers did everything they could during this period to bury or obscure the influences of Greek philosophy in alchemical thinking, and particularly with Qabalah. One of the chief reasons Protestants were particularly fascinated by Qabalah was that they believed it would provide a means of interpreting scripture independent of the whole tradition of Pagan philosophy as came down in Plato and Aristotle, which had been a large part of Catholic thinking. Rather than relying on Plato or Aristotle, the esoteric Protestants relied on Qabalah. At this time the esoteric wing of Protestantism was very large and vocal, (How modern fundamental Protestantism would be appalled at the occult orientation its distant forbearers!) so they jumped at the idea of Qabalah and alchemy as being the key to understand religion, and in particular this is the period you start seeing a great deal of Alchemy as part of an esoteric commentary on the Bible, or secret teachings that were hidden in the Bible.

Anyone familiar with modern Biblical scholarship will realize that it is practically impossible for there to have been some secret, hidden subtext within the Bible, because of the fact it was welded together out of

images or stories in the 3rd and 4th century B.C.E.. Even to the extent that single verses of the Bible are made up of two different previous versions of that story. So there is no way you can argue that there is a hidden subtext in the Bible as it exists now. Anyone who wants to do that is simply living in a fantasy world. Which is not to say that there is not a lot of striking images. And these striking images allow you to read into the Bible almost anything you want. But, as a source of even Qabalistic wisdom, much less alchemical wisdom, it is a waste of time. You are far better off reading Greek philosophy and Greek thinking.

The Protestant rejection of Greek thinking is why they went to reading these things into Biblical sources.

And Paracelsus is such a hero to them for two reasons: First of all he was associated with the Reformation in medicine and in religion. Secondly He was very much a self promoter and wanted to make a great deal about things that he did or was working on; and in many ways they were not as big a deal as he put across. That's not to say that there isn't value in what he was saying, it's just that it's not so great and amazing as he would like you to think.

An important factor to take into account here is the 19th century occultists who wanted to find a bridge between occultism and science. They looked for people who were heroes of science to particularly make a big deal about them. In the 19th century Paracelsus was considered to be "the founder of modern medicine," so what better person to point out their alchemical studies and associations with occultism and say, "Well, Paracelsus the founder of modern medicine was involved in alchemy and astrology and therefore it must be good." Even to the extent that Madame Blavatsky, when she wished to look important chose Paracelsus as a previous incarnation.

A humorous side note about this is that the person who is virtually the founder of physics, (I hate to say modern physics, 'cause it's not modern anymore!) but certainly one of the major founders of physics is Isaac Newton and the irony is that Newton in his unpublished studies spent almost all his time with

alchemical texts. Had the 19th century apologists for Occultism known enough about Newton's private interests they could have said instead that Newton was the founder of modern physics and was in point of fact an alchemist. Unfortunately this information did not become readily known until after the middle of the 20th century.

So, to recap, one of the reasons to study history is to get deeper insights, in particular when you start to study the history of alchemy you discover that its origins are probably much different than most people think. It seems to have arisen from Greek thinking and the driving force behind it was probably meditation practices. It is important to recapture a world view in order to understand alchemy and this world view is more accurately and powerfully encapsulated in Greek thinking than in anything most modern alchemists are likely to be reading like the Bible or the Qabalah or other things like that.

The importance of the Greek world was more or less glossed over and lost during the period of the Reformation, and when the alchemical revival took place in our 20th century, people came to it with a large number of preconceptions that are not useful. If people really want to get the most out of their alchemy they would be better off reading Plato and Aristotle rather than even Indian texts.

STUDENT: The reason why the Protestants had such an axe to grind with the Church was that the Church...didn't they have some kind of doctrine of Pagan revelation?

Well, yes, the Church late in the Hellenistic period had developed the Doctrine of Prisci-Theologicae and this is dealt with in detail in Bruno and the Hermetic Tradition by Yates. Basically in order to be a Catholic church, in other words one that was both for Jews and Gentiles they had to unify Greek and Hebrew thinking. They invented this basic myth, or actually the myth came trickling down from the time of Posidonius who was a stoic philosopher of the 2nd century B.C.E.. (By the way this fellow Posidonius is probably one of the most influential characters in Western history, because he was one of the people who helped create the intellectual basis for astrology and for a great deal of what we would now call esoteric practices, by putting Stoic philosophy and Platonic philosophy in a particular perspective.) One of the other things he did, and he may have gotten this from his teacher Panaetius, was to teach that the Jews had the correct ancient monotheistic religion. Both Greek and Egyptian religions were viewed as later degenerations from it and that Moses at the time he left the ancient Egyptians had basically taken the true ancient monotheistic religion and had settled with the Jews in Israel and had preserved it from remote antiquity to the period in which he (Panaetius or Posidonius) was writing. Subsequently to Moses both Greek and Egyptian religions had degenerated into polytheistic religions. Naturally this created something of a fashion for Judaism during the Hellenistic period, which



even carried over into the papyrus magical texts.

The importance of this is that by the time we reach the second or third century C.E. the Egyptians were looking for a suitable mythical person on whom to hang these Greek ideas so they could say that they weren't Greek ideas but secret oral teachings of ancient Egypt. Hermes, a mythological figure, was chosen and a whole new mythology was invented about him as either a contemporary of Moses or existing in antiquity before Moses.

What you had was the mythos that either Hermes and Moses were contemporaries or Hermes was prior to Moses and that there was an ancient theology which had been taught in the Corpus Hermeticum and in the writings of Hermes and that it had two versions: One which became enshrined in Hebraic scripture, and one which came down as Hermetic writings. The Hermetic side, the pagan side, had a whole family tree; it basically went Hermes, Moses, Orpheus, Zoroaster, Plato, Aristotle and oh, Pythagoras is in there some where too, and these were the ancient theologians. This was the myth that the medieval and renaissance church basically subscribed to. I think it reached its maturest form in the church writings of Lactantius who wrote in the sixth century CE. This is detailed at great length in Bruno and the Hermetic Tradition.

Protestants believed that the primary reason the primitive Christian church had been so corrupted was from these "filthy" pagan influences, so they tried to replace the Pagan influence with "real" "meaningful" Hebrew things or with the "inspiration" of the "Holy" Spirit, which is an important issue because it is from the Protestants in particular that we start to get a degeneration in esoteric circles of the importance of the reasoning mind. The pagans were very fond of the reasoning mind and so were the Catholics. If you've ever tried to debate theology with a Jesuit you'll know.

Of course the Protestants were trying to debate theology and I suspect that they were probably losing a lot. So, what they basically said was "your meager human pagan logic does not outweigh the inspiration of the Holy Spirit which is now showing its true interpretations of the scripture, so you filthy worshippers of the Anti-Christ can all burn in Hell, because Luther has given us the true religion." Much of the anti-intellectual characteristic of occult thinking also originates in the Protestantism of this period, but was later exacerbated by the rise of Romanticism in the 19th century. After the 1800's when European society basically split into two warring camps of Romanticism and Reductionism. By Reductionism I mean the position of people who wish to reduce all phenomena to merely physical activity and who go around claiming falsely to be rationalist. Reasoning and thinking and rationality became linked falsely with Reductionism, so people began to think that logic and reason lead you to materialism (which in fact they don't) so logic and reason must be bad. Plato's devastating criticism of materialism had made it so laughable and so intellectually unacceptable that for almost 1800 years no one would put materialism forth seriously. Of course his criticism was based very much on terms of logic.

So in any case, the Romanticist movement, of which the modern occultist movement is a branch, inherited its anti-intellectualism from certain parts of the Protestant radical fringe who were very deeply involved in a revival of alternative world views which they wished to put in Biblical terms.

STUDENT: Would there have been Rosicrucians if the Reformation had not taken place?

That's a curious question. I suppose it depends on what you mean by Rosicrucians. It's not at all clear, but in terms of the historical form that was taken, there probably wouldn't have been "Rosicrucians". But whether or not there was some sort of an esoteric order that was a secret society and was active, whether there was an actual secret society that proceeded the unfolding of the Rosicrucian manifestos is an interesting question of itself.

John Robinson's very suggestive work Born in Blood makes an interesting case for the survival of the Knights Templar and their eventual resurfacing in the Masonic Movement. I don't consider the account conclusive, but he does give someone an interesting direction to go to create a more convincing account. It may be that the surviving Knights Templar made a first bid to resurface in the form of the Rosicrucian Manifestos.

Also interesting is a little tidbit that I ran across in a book that I hope to be able to find again at some point, and it's almost tragic, because we may never find the truth of the matter, because among other things the evidence may have been destroyed in the fire bombing of Dresden; but this little book was written at the turn of the century, and mentioned that in the Royal Museum of Dresden there were two rings said to have been the possessions of Martin Luther. One of these rings was a cross with a rose, and if that is indeed correct and Martin Luther did have a ring with a rose on a cross, then something funny may be going on here.

There were certainly pious movements within the church reaching back to an early period. Again this simply illustrates how much we have lost track of what was going on in the church. They had these huge rose windows in many of the cathedrals and the cathedrals were laid out as crosses. So to an enormous extent the cathedrals in themselves were rose crosses. In Dante's Paradiso the rose is the primary image of the church, etc. This may indicate that there was some type of organization going on in the medieval period that ties in with the idea of roses and crosses and is linked in Gothic cathedrals and other things like that.

Some of the modern alchemical works that talk about interpreting the mysteries of the cathedrals may not be far off. It's just that interpreting the mysteries of the cathedrals is just like interpreting the alchemical emblems I mentioned earlier. Without the key of the world view you're likely to take things totally out of context.

STUDENT: But if your "system" is well formed

maybe you'll still get information.

True

STUDENT: Because I am wondering...

Well, this is where you get down to the whole business of alternate paradigms and all that. A good case could be made for defining alchemy and spagyrics as Aristotelian chemistry. And here is a great tragedy: that most people are not aware of this! Basically the Hermetic world view seems to be the result of taking classical Greek thinking and applying it to a physical process, with possibly some ideas drawn from internal meditative practices. By studying Classicism one can get some very profound insights into Hermeticism, Qabalah, etc.

However, when you start to look at things like Alchemical Emblems and the Cathedrals you can get good information out of them, but it just may not be what the people who encoded it had in mind. The world view provides the context in which the symbols must be interpreted, and unless you approach the problem of interpretation from the same point of view as the people who created the metaphor, you can completely misinterpret the matter. The cathedrals, if they had been done as mnemonic devices as the emblems probably were, are not ciphers; they are allegories, or images/metaphors, and for that reason there can be multiple texts. The same goes for the mythology of any era or region, because of its richness multiple interpretations are possible. This is why you can find useful insights in mythology, including the Judao-Christian mythology in the Bible, but it cannot be used as an argument that that is what the author intended, and that Alchemy must have an origin in remote antiquity; it's just too vague.

If you take a text that has been legitimately ciphered by a cipher table, it is very unlikely that you will be able to read a good alternative text of it. It would be an incredible piece of luck if you had a paragraph long enciphered text that you could read two different, coherent texts out of that single cipher... it would be almost impossible. Of course the shorter the text the better the chance of getting two good readings out of it.

When you are looking at something where the intent is not a strict encipherment, but is a striking image such as these alchemical emblems the intent is probably as mnemonic devices. That is probably their origin, but by the time we get to the 17th century the emblems may have acquired their own meaning and dynamics, but I would say that the origins are largely in the "art of memory," rather than in the art of meditation. If they were later used for meditation, who knows... But when you look at the internal practices of alchemy in other cultures you just don't see those types of images, and we'll look at that later.

THE END!

**Now Available on Video  
Cassettes!  
LPN-USA Chicago Seminar,  
October 1992  
Featuring Jean Dubuis**

These tapes provide comprehensive coverage of the entire seminar. Included are extensive notes to help follow the topics covered and a detailed "table of contents," complete with timer lengths so you can zip to your topic of interest quickly and easily. This is a real help when you are wading through 16 hours of material!

Here are just a few of the topics covered:

*SEPARATION OF ANTIMONY*

*MAKING FURNACES*

*THE PATH OF NICOLAS FLAMEL*

*MAKING THE MARTIAL REGULUS*

*THE KEYS OF BASILIUS*

*THE BUTTER OF ANTIMONY*

*THE ENS IN PLANT WORK*

*DISTILLATION OF ANIMATED MERCURY*

*THE STONE OF ETERNITY*

*HOW TO BUILD AN INCUBATOR*

*THE SECRET FIRE*

*...AND MORE!*

The seminar is recorded on 3 quality video cassettes, covering about 16 hours, and includes a 64 page booklet. The cost is \$69.95, post paid.

Please send your order to:

**LPN-USA  
Box 11218  
Boulder, CO. 80301**

# Who was Franz Bardon?

*by Tim Scott*

Franz Bardon is one of the most intriguing but least known occultists and magicians of the Twentieth Century. He is mainly known from four books he wrote that were published in the 1950s. He must have been doing something right, since his books are still in print (or were until just recently). Since many occultists have borrowed his techniques and terminology—knowingly or unknowingly—without giving him proper credit, it might be interesting to look a little more closely at his system. For example, I once recommended Bardon's "Initiation into Hermetics" to a person who had studied occultism for some years. He was stunned to find that a teacher of his in the past had made Bardon's materials part of his teachings, pretending he had written them himself.

Bardon was unusual in stressing practice and practicality above all else. Although his books contained lengthy theoretical sections, his emphasis was on the tangible, usable results of magical training. His stated purpose was to give the serious student of magic the most complete and best possible magical instruction obtainable outside of an occult lodge and without the benefit of a personal teacher. Did he succeed in doing this? Ultimately, the only way to find out is by trying his curriculum yourself.

In this article we'll examine what little is available about Bardon's life, in the context of German occultism of the mid-20th Century. Following that is an examination of his occult theories and system. Finally, a brief annotated bibliography is given for further research.

## Bardon's life and work

Bardon did not appear to be trying to create a legend about himself, and the only self-references in his works are occasional attestations that he had himself tried this or that experiment or ritual. I can't resist comparing this to a much more famous magician of this century who wrote voluminously about his own life and adventures, and had no qualms about glorifying himself while so doing.

According to his student and close friend Otti Votavova, Franz Bardon was the oldest of 13 children, and the only son of a very devout Christian mystic, Viktor Bardon. Although he had achieved a certain amount of spiritual advancement, Viktor felt that he was unable to obtain an advanced initiation, and prayed that he be allowed to be given this blessing. The story is that an advanced soul entered the body of his son Franz to become Viktor's initiator.

In later life, Bardon became a stage magician who gained some fame in Germany in the 1920s and 1930s under the stage name "Frabato". I have been unable to find out anything more about this period in his life from my researches in this country.

As Adolf Hitler and his Nazi party ascended to power in the 1930's various groups such as the O.T.O. and the Freemasons were banned and some of its members arrested. Otti Votavova avers that Hitler was belonged to the legendary "FOCG" or "99" Lodge of black magic, described in Frabato the Magician and Fire and Ice (see the bibliography). Apart from this, Hitler and some of his intimate friends were supposed to be members of the "Thule-Order," which was the external instrument of a group of powerful Tibetan black magicians.

## Arrest and imprisonment by the Third Reich

Through the negligence of one of Bardon's disciples, who had not destroyed their correspondence as Bardon had ordered, the Nazis arrested and imprisoned them both in late 1941 or early 1942. While the prisoners were being whipped, the disciple lost his control and uttered a qabalistic formula to immobilize the torturers.<sup>1</sup> However, the effects of the formula were eventually cancelled and the disciple was shot for revenge.

Adolf Hitler offered Bardon high positions in the Third Reich under the condition that he help win the war by the use of his magic faculties. Bardon was further expected to reveal to Hitler the address of the other 98 of the 99 Lodges spread all over the world. When he refused to help, he was exposed to the most cruel tortures. Among other things, they performed operations on him without anesthesia, and forged iron rings around his ankles and fixed heavy iron balls to them.

Bardon endured the torments of Nazi concentration camps for three and a half years. In 1945, shortly before Germany surrendered, he was sentenced to death. Before the sentence was executed, his prison was bombed by the Allies. Bardon was rescued from the heavily damaged building by some Russian fellow prisoners and, with their help, succeeded in hiding from the police until the end of the war and worked his way back to his home town.

After the war Bardon found, by the help of his magic abilities, that Hitler had escaped abroad. For fear of

recognition Hitler had undergone a number of surgical operations on his face.

Bardon's long-time publisher, Dieter Rugeberg, makes this comment on the above statements: "So much for Otti Votavova's recital of facts. In the years of my acquaintance with her I was able to convince myself of her love of truth."

After regaining his freedom, Bardon recommenced his occult work and healing. It was apparently this last work that got him in trouble with the Czech authorities, as this type of thing was strongly discouraged in the very repressive political climate of postwar Czechoslovakia.

## Arrest and death

About Bardon's last years, Rugeberg wrote to me as follows: "The profession of Bardon was natural healer. He was able to cure cancer until the 2nd degree, without steel and rays, only with his own medicine made from plants and treated with alchemical means. For this reason the doctors of the official medicine became very jealous, because they could not reach such success with their chemical and nuclear treatments. After the publication of his books in 1956, a number of people came from Germany to visit him. The doctors took this opportunity to accuse Bardon to be a spy from the West, and that was the reason he was arrested in 1958 in Opava, Czechoslovakia." Czechoslovakia's leaders were fully in line with Russian Communist ideology, resulting in persecution for free-thinkers, Gypsies, Jews, Freemasons and anyone interested in occult or esoteric subjects.

Bardon died July 10, 1958, but what connection his death had, if any, with this arrest I have been unable to determine. If he was a professional magician in Germany in the 1920's and 1930's, we could assume that he was born roughly around the turn of the century, and thus would not have been very old at his death.

## The Fraternity of Saturn

Bardon stoutly maintained that he was not a member of, nor under any obligation to a magical lodge or order. However, some sources indicate that he was actually a member of the "Fraternity of Saturn" (called "FS" hereafter), an important occult lodge which flourished in Germany in the early part of the 20th Century. During the ascent of the Nazi party, all Masonic, religious and occult organizations were banned. The FS Lodge was banned by the Nazis sometime between 1933 and 1937, but was revived in 1950.

I have not yet been able to positively identify Bardon as a member of the FS. While recognizing the power and validity of sex-magic, Bardon discourages the student (in the most emphatic terms) from dabbling in it until he understands its full implications.



## Franz Bardon's writings

Each book follows a roughly similar pattern: a mainly theoretical exposition followed by practical instruction. Reading and understanding them is a challenge, as they have been translated from German—and possibly from Czech before that—into non-idiomatic English.

Translation difficulties aside, one thing that makes an enduring impression is Bardon's evident sincerity. He insists frequently that he is doing as much as can be humanly done to transmit a system of occult development to the serious student who is either unable to find a teacher or work in a group. In line with this, he also frequently reiterates that he has personally performed such and such an experiment, ritual or procedure.

## His Sources

Before describing some of Bardon's theories, it is good to keep in mind that many of the words he uses have different meanings in regular life and even in other occult systems. For instance, the terms impregnation, fluid, condenser, and sphere, all have special meanings.

Bardon appears to have originated the concept of the so-called "fluid condenser" which is seen in some recent books. "Fluids" are magical qualities, not fluids as chemists or cooks would understand them, and are divided into "electric" and "magnetic" types. A "condenser" is a magic wand, mirror, or other device the magician crafts to "condense", or concentrate these fluids. An example of preparing a fluid condenser is given below.



Some of his occult ideas can be traced to earlier works, such as Eliphas Levi and Francis Barrett's *The Magus*. Bardon also seems to have been familiar with Tibetan occultism, or at any rate the works of Alexandra David-Neel, whom he cites now and then and from whom he has done a fair amount of borrowing. He mentions, for example, kylichors (magical diagrams), and tum-mo (the ability of Tibetan adepts to stay warm in freezing weather).

The mental exercises he prescribes, such as "one-pointedness," watching the roaming of consciousness, and so on, are frequently seen in yogic and other occult works.

Although Bardon does not mention Crowley or any of his writings, the Beast's influence is still present. Compare Crowley's famous dictum: "Love is the law, love under will" to Bardon's: "Love is the law, but love under a strong will."

## Bardon's theories: The Magical Universe

Bardon postulates an energetic model of the universe modified from Far Eastern theories including Taoism and Hindu cosmology. He defines an "electric" and a "magnetic" fluid which are complements to each other in the same way that Yin and Yang are. The magnetic fluid is a cool, negative force with a blue emanation, and the electric fluid a warm, positive force with a red emanation.

In Initiation into Hermetics, he refers—only once—to the "OR" and "OB" forces. My guess is that these might represent the "Red" (OR = Odyle Rot) and "Blue" (OB = Odyle Blau) or electric and magnetic fluids. Or perhaps they are adaptations of the OD and OB forces described in Eliphas Levi's *Transcendental Magic*. Whatever the scientific validity of this approach, it is certainly rich with suggestive possibilities.

Bardon's "od" energy also has antecedents in the theory of the "od" or "odyle" energy, which was originally developed in the mid-1800s by Baron Karl von Reichenbach<sup>2</sup>. The negative pole of a magnet, he claimed, appeared blue to persons with high psychic sensitivity and induced a feeling of coldness. The positive pole appeared red and had the property of warmth. He elaborated this theory into a highly complex system of occult anatomy and mysticism. Bardon usually called od "vital power" ["*Lebenskraft*"], but once or twice reverts to the term "od."

Bardon teaches that each part of the body is governed by either the electric or the magnetic force, or it may be neutral. Disease is caused by parts being out of balance energetically. Here again are analogies with other systems of healing such as the Chinese which describes the flow of life energy ("chi" or "qi") through meridians or channels.

## The Four Elements

Bardon made use of the ancient four

elements—fire, earth, air, water—plus akasha or quintessence. His attributions of the elements are essentially the "classical" ones: water for emotions, intuition, fire for aggressiveness, passion, etc. In his view, the skillful magician was one who could manipulate the elements to achieve desired effects. Of course, before the student could become master of the elements, he had to harmonize and control the manifestations of all elements in his own being. This is central to Bardon's paradigm.

Bardon taught that man was superior to all spirits, demons and angels in that only man was a "four-pole" being, that is, partaking of the energies of all the elements. For instance, gnomes are strictly creatures of earth, sylphs of air and so forth. He cautioned the student to beware of tricks and deceptions on the parts of these creatures, who wish to capture a part of the human's soul. Exactly how this is done he does not explain.

"The alchemist," he writes, "will recognize that the human body represents a genuine Athanor in which the most perfect alchemistic process, the great work or the preparation of the "philosopher's stone" is visibly performed."<sup>3</sup>

## Akasha, or the Ethereal Principle

Akasha is the metaphysical realm or sphere in which wishes become reality. Bardon states: "Any deliberate cause, may be such as a wish, a thought or any imagination created in this sphere together with the dynamic concentration of willpower, unshaken faith and fullest conviction is bound to be realized with the help of the elements..."<sup>4</sup> Consciousness knows neither time nor space, and is therefore an akasha principle. He frequently makes the point that you should redissolve the akasha into the universe rather than keep it accumulated. In other words, the "magical" frame of mind should not be the same as the everyday one.

## Preparation of the student

A pillar of Bardon's method is the point that the magician must be balanced in the elements that make up his own being. A student with an excess or lack of any element could not obtain great success, no matter how much work was done. An analogy would be an auto engine: no matter how much fuel you feed to it, it can only generate so much power if it is not properly tuned and balanced. After a point, the engine will either wear out quickly or fail if you attempt to make it perform beyond its design limits. The difference with humans is that our limits are self-imposed.

He is also insistent on the point that the student begin at the beginning and not skip any section of his training. Each step must be completely mastered before proceeding on to the next. Again the analogy to other endeavors is clear. If magic is a skill like flying, then the student cannot neglect the study of airplanes, weather, safety, aviation electronics (avionics), and so forth, without serious difficulties in the future.



Finally, as many teachers repeat, the student must keep a complete and accurate record. Without this, it is hard to repeat successes and avoid repeating mistakes.

## Outline of Bardon's Magical Curriculum

Although Bardon divides his praxis into ten steps, these seem somewhat arbitrary. The main points he makes are summarized below.

### 1. Self-analysis & basic exercises

As mentioned above, the student must work diligently on understanding and harmonizing the four elements within the his own being before any further occult work is done. Bardon prescribes several weeks of minute, mercilessly honest self-observation and recording of your faults and failings. The goal is to class these under the four elemental categories and see which elements are out of balance in your Self. A similar exercise classifies your virtues and strengths.

The point of these exercises is clear in the light of his system. Since the magician is to have control over all the elemental worlds, he must perforce not have any unbalances or obsessions that would impede his effectiveness, or allow weak spots that could cause his undoing. In later steps the wisdom of this approach becomes clearer.

### 2. Intermediate concentration & breathing

The student deepens his abilities of concentration and performs breathing exercises and the techniques of autosuggestion, which Bardon regards as the secret of subconsciousness.

Bardon distinguishes carefully between two kinds of breathing: Pulmonary (normal) and through the skin. This second type of breathing takes practice. The body can respire automatically, but the student needs to learn to control it, combine it with voluntary pulmonary breathing and selectively inspire the various elements and akasha.

### 3. Advanced visualization exercises & element manipulation

This step entails intense concentration on and visualization of increasingly more complex objects, and the "inhaling" of elements into the body. He also learns the "loading" or charging of talismans, rooms, or objects for protection, healing or other purposes.

### 4. Accumulation of elements & "rituals"

In this part of the training the student is expected to perfect the balancing and concentrating of elementary energies in the student's own and other persons' bodies. In Bardon's system, "rituals" are not what we normally think of as such, but rather mnemonics based on hand gestures, verbal formulas or visual keys. He claims that once the energies are understood properly, you can recall an energy or situation with simply a surreptitious hand gesture, a silent formula or a combination thereof.

### 5. Transplanting consciousness and levitation

This step consists of a series of graduated exercises designed to prepare the student for physical and astral levitation and astral travel, as a prelude to communication with astral beings. Communication with the astral world can be either active or passive. Passive techniques are simpler and safer and are thus presented first.

### 6. Introduction to astral beings and astral travel

In addition to the matters indicated by the heading, this chapter also deals with the creation of non-physical beings for the magician's use. The perils of accidentally creating them are also discussed. This inadvertent creation of "phantasms" which can attach to and vampirize the operator is a great danger for the dabbler in occultism. At this point, Bardon reiterates his insistence that the student not skip over any step in his development, in order to avoid this serious problem.

### 7. Development of clairvoyance, clairaudience and other abilities; creation of elementaries

Bardon describes techniques for creating special accessories such as eye-baths and ear-plugs to aid in development of supersensory perception. Bardon continues the discussion of elementaries started in the previous section, and devotes considerable space to their creation, for which he gives four methods. Interestingly, he also describes how the elementary is removed from the object containing it, and proper means of disposal of the object.

In this section he also discusses magic animation of pictures and statues.

### 8. "Fluid condensers"

These are special tools created by the magician to concentrate, store and manipulate the electric and magnetic fluids. He gives fairly detailed instructions for making, charging and using these "condensers," of which the following is an interesting example:

Take a handful of fresh or dry chamomile flowers, put them into a pot and pour so much cold water over them until they are covered completely. Let the chamomile flowers boil for about 20 minutes. Cool them, but leave the lid on the pot and strain the decoction. Put this on the fire again and allow it to evaporate slowly until it weighs about 50 grams. A few drops more or less do not matter at all. Let the extract cool and, for better preservation, mix it with the same quantity—in this case 50 grams—of spirit or alcohol. (Remember to never use methyl or wood alcohol in any preparation meant to be used in or on the body.)

To this mixture add about 10 drops of the gold tincture prepared above. Bardon continues: "If you wish to use the condenser for your own purposes, you may still strengthen it, by adding a drop of your blood or sperm, if possible both together, on a swab of cotton

wool, throw this afterwards without any scruples into the condenser and shake the lot well. Then, pour all, in a funnel, through filter-paper or linen into a small bottle and keep it, well corked in a cool and dark place, ready to use.<sup>5</sup>

These condensers can be used in many ways: mixed with liquids which are to be drunk, used in anointings, mixed with incense compounds, or poured in small bowls to collect and concentrate certain energies.

Bardon continues: "Any fluid condenser which has been prepared in this manner does not lose its efficiency even after many years. The condenser must be well shaken each time you are going to use it, the bottle is to cork again after withdrawing some out of it. In the same way you can prepare several universal condensers from Russian or genuine Chinese tea, from lily-blossoms-best are the white ones- poplar leaves, alraune roots or mandragora roots, arnica montana, acacia flowers. Any simple fluid condenser, prepared from one plant is sufficient for normal use such as influencing through the elements, or developing the astral senses by means of the fluid condensers."<sup>6</sup>

#### 9. Magic mirrors for astral travel & healing

The magic mirror (of which the crystal ball is a species) is valuable for many experiments in clairvoyance, clairaudience, and the like. After a brief description he lists many ways it can be used. He describes treatment of the sick using electro-magnetic fluids, magical loading of talismans, amulets and gems.

#### 10. Elevation of the spirit to higher levels

This chapter discusses the various ways the student should improve his spiritual qualities. Bardon wraps up with a discussion of a number of occult topics such as exteriorisation, levitation, production of natural phenomena, suggestion, hypnosis, psychometry, and long distance impregnation of rooms.

### A remarkable book on communicating with spirits

Bardon's second published work, The Practice of Magical Evocation, is a unique and very remarkable work of nearly 500 pages. The first of its two parts is an exhaustive description of the many tools and apparatus the magician needs to work. The topics dealt with include: The Magic Circle, Triangle, Censer, Mirror, Lamp, Wand, Sword, Dagger, Trident, Crown, Cap and Magus-Band. This book is much more ceremonially oriented than the first, which requires a minimum of apparatus by the student. Practice is actually a classic magical grimoire or instruction manual, one of the few modern ones that can be properly so described.

The second part gives a huge catalog of spirits or entities that the student is supposed to be able to contact after perfecting the techniques in the first

book. A short paragraph accompanies most of the entries explaining the specialty or purpose of the being and what skills, knowledge or advantage it can bring the occult practitioner. Bardon states several times that he has contacted all these entities himself and is writing what he knows in the first person. In fact, he says there are many more entities he has omitted, due to their unsuitability for beginners.

The names of these spirits are quite interesting. A very few of them are the same as the corresponding names in the "classical" magical tradition. His "72 spirits of the Mercury sphere" correspond almost exactly to the 72 angels of the Schemhamphorash. Some of them are oddly changed. For instance, "Osrail" is clearly the same as "Azrael", and "Opollogon" appears to correspond to "Apollyon". These spirits are described in Barrett's Magus among other books. The change in spelling might be due to the fact that Bardon wrote originally in Czech or German.

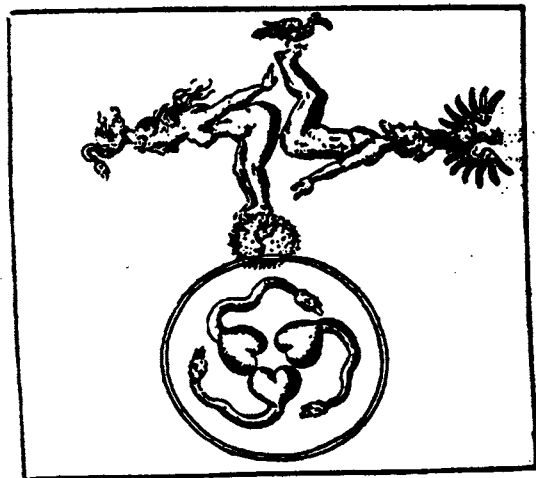

However, most of his other spirits I have not yet been able to trace names for. For instance, the following are some of the spirits of the Mars sphere, none of which I can locate in other references: Rarum, Gibsir, Rahol, and Adica. These names may be from an obscure medieval grimoire, have different meanings in Czech, or have some relation to his own qabalistic system, but I have so far been unable to make such a connection. I certainly would appreciate being enlightened on this point.

### Bardon's Unique Qabalistic System

After the second book, the coherence and organization of Bardon's work deteriorates noticeably. His third published work was The Key to the True Quabbalah. His qabalistic system depends on the sounds of the various letters of the alphabet. It's not clear that this was exhaustively thought out, since there are many alphabets in use (even in Western languages). For example, Hebrew, Cyrillic, Coptic and Arabic all have different alphabets, and some (Chinese) have no alphabet at all. He uses his qabala somewhat differently than other occultists: he connects qabalistic formulae to various processes (e.g., a

vibration consisting of the sounds "KTM" is a formula to load a room for protection, "AAQ" is used for remote healing, etc.)

It is also used as a sort of shorthand: once the occultist has made contact with some planetary intelligence, for instance, he can re-contact the intelligence by using its "phone number" for simplicity. Perhaps the best use of the Key is as a springboard for further research, as it could be that the key to the Key was only given to his students directly.

### Later books of rough quality

It is pretty clear that after the first two books, much less time or assistance was available for Bardon to get his later books into print. Perhaps he was incarcerated or deceased and unable to help with the editing. In any case Bardon's production after this point declined rapidly. The next book was Erabato the Magician which was fleshed out from Bardon's unedited notes by his publisher. However, this is a very intriguing occult novel somewhat along the lines of those of Dion Fortune.

Some fascinating material follows the novel. These are rough notes for later books that Bardon intended to write. His original goal was to write 22 books, each one explicating one Tarot key. However his Tarot keys were unlike any other, and each of the first three books has an attractive color reproduction of the key associated with it.

### Franz Bardon today

As mentioned above, Bardon's books are still available. A few years ago, the "Franz Bardon Foundation" was started in Denver, Colorado by an enthusiastic student of his works, who showed his devotion to the "Magus Guru", as he called him, by changing his name to "Jim Bardon." For a time, I subscribed to his newsletter, which was 4 or 8 pages and issued a few times a year. This newsletter was, I am sure, a sincere effort and often had interesting and useful ideas. Unfortunately, it also included much peripheral matter that seemed to have no direct connection with Bardon's works. Each issue repeated much of the same information about "Jim Bardon's" predictions of major huge depressions and at least one world war between 1989 and 2005. However, there is nothing in Franz Bardon's own writings that would support these theories. Furthermore, Jim Bardon in his bulletins also advertised his own publications, astrological service and hermetic training.

I lost contact with him when he raised the yearly subscriptions for his newsletter from \$25.00 to \$50.00—in order, he said, to separate the sincere from the frivolous.

The last information I have of the "Franz Bardon Foundation" is from a classified ad in the March/April 1991 issue of the Llewellyn "New Times". A phone number in Seattle, Washington was given.

### Summary of Franz Bardon

## and Editorial

Perhaps it is unfair to make such comparisons, but it might be interesting to contrast Franz Bardon's works with those of the another much-better-known magical teacher of this century, Aleister Crowley. Although when the spirit moved him, Crowley could be intensely disciplined, magnanimous, kind and helpful to his students, he also enjoyed a life filled with sex, drugs, alcohol and bon vivant, all of which were integral parts of his magical philosophy. Crowley was continually heaping praise on himself, excoriating those he felt beneath him, casting aside students as unworthy, and continuously justifying his behavior. He praised strength and sneered at weakness. Crowley's writings are full of literary practical jokes, insults to the reader's intelligence, and deliberate deceptions.

Bardon, on the other hand, seems to represent almost everything that Crowley does not. He appears to be patient, devout, non-judgmental and earnest. He insists that only through balance and purging of excesses could success in magic be obtained. And—though it may only reflect my personal biases—it seems that Bardon's reticence and cautionary tone in the matter of sexual magic is a much more reasonable attitude than Crowley's, especially where the beginner is involved. Certainly not one occultist in a thousand has made reasonable use of sex magic, whereas an unfortunately large number have become obsessed or worse. Have you ever met anyone or heard of anyone who has become a better person or even a better magician through the use of sex magic?

In short, I feel that Bardon does indeed deliver what he promises: detailed magical instruction for the diligent and serious student who, for whatever reason, cannot or will not attach to a magical order or group. It is sometimes a challenge to penetrate the mediocre translations of his works, but with supplementary magical study things do become clearer.

## Bibliography

### Franz Bardon's works

(German)

Der Weg zum wahren Adepten First edition 1956. I have a copy of the 10th printing (1989) by the same publisher (Hermann Bauer) which first published the first edition.

Die Praxis der magischen Evokation (1st ed. 1956)

Der Schluessel zur wahren Quabbalah (1st ed. 1957)

Erabato: Ein okkultur Roman (1st ed. 1979)

(English)

"IIIH" Initiation into Hermetics (1st English edition 1962)

"PME" The Practice of Magical Evocation (1st English edition 1967)

"KTQ" The Key to the True Qabalah (1st English edition 1971) (The formulas discussed above, to immobilize one's enemies, are discussed in this book under the headings "E-M" and "E-N".)

"FRA" Frabato the Magician (1st English edition 1981)  
This was an "occult novel" which Bardón's student and friend Otti Votavova claimed was based on true events. This edition also contains fragments from a work that Bardón was never able to complete, published under the title of "The Golden Book of Wisdom", and an unpublished tract entitled "High Magic."

#### Related works: English

(The dates given after the titles are the years of first English publication. Most of the works listed below have been reprinted in various formats, some many times.)

Barrett, Francis. The Magus, or Celestial Intelligencer..., London (1801), reprinted many times. For information on "classical" demonology.

[Cavendish, Richard, ed.] Man, Myth and Magic (1970) See articles on "Magnetism" and "Double" for information on Baron von Reichenbach's theories.

David-Neel, Alexandra:  
Magic and Mystery in Tibet (1931)  
Initiation and Initiates in Tibet (1932) Referred to in a few places by Bardón.

Flowers, S. Edred (pseud. of S. Edred Thorsson?) The Fraternity of Saturn (1990). This is surprisingly good. It is well-documented and relatively sane. Of course, in order to sell the books, the sexual magick aspect of the F.S. is emphasized.

Howe, Ellic. The Magicians of the Golden Dawn (1972) See p. 282, Note 1, on the banning of the Fraternity of Saturn.

King, Francis:  
Sexuality, Magic and Perversion  
The Secret Rituals of the O.T.O. (1973)  
The Magical World of Aleister Crowley (1977)  
Although long on sensationalism, King's works are usually reliable and relatively well-documented.

Levi, Eliphas (pseud. of Alphonse Louis Constant, transl. by A. E. Waite). Transcendental Magic (1896) This is an English edition of Dogme de la Haute Magie (1855) and Rituel de la Haute Magie (1856).

Ruggeberg, Dieter. Personal communication, Oct. 28, 1988 Herr Ruggeberg, the long time publisher of Bardón's books in English, wrote this in response to a query for more information about Bardón's life.

von Reichenbach, Karl  
Physico-Physiological Researches on the Dynamics of Magnetism, 1850, 1851

The Odic Force: Letters on Od and Magnetism, 1926, reprinted 1968

Wilson, Colin. The Occult (1971) For information on von Reichenbach's theories.

#### Related works: German

"Blatter fur Lebenskunst," ("Magazine for the Art of Life") August 1956, p. 3

Gregorius "Magische Erweckung der Chakras in Aetherkorper des Menschen" ("Magical Aspects of the Chakras in the Ethereal Body of Man")

Jurgens, H. "Die Tesbihschnur"

Winckelmann "Das Geheimnis des Talismans und Amulette" ("The Secrets of Amulets and Talismans")

#### Notes

- 1 See the Bibliography under "The Key to the True Qabalah"
- 2 See Bibliography.
- 3 "Initiation into Hermetics", p. 30
- 4 Ibid.
- 5 Ibid., p. 197
- 6 Ibid.

## Alchemy: The Minor Opus

### *A Treatise on Plant Alchemy*

by John Reid

Over twenty-seven actual color photographs of the laboratory process. Includes the stone going through separation, putrefaction, green, white and citrine stages. Printed on 107 acid free spiral bound pages.

Cost is Thirty-Five Dollars and includes first class postage to any address in the continental U.S. Orders outside the continental U.S. (shipped via fourth class book post or UPS) add an additional \$2. Payment must be made in U.S. dollars by international postal or bank money order payable at a U.S. bank.

*The first printing of this book is limited to 250 signed and numbered copies.*

Send payment to:  
John Reid, P.O. Box 223, Pelham, N.Y. 10803

# TINCTURE TARTARI

Edited From Commentary of LeFebure

As Read Aloud By Michael Junius & Transcribed by A.M. House

## Process:

Take well cleaned Tartar in a fire proof pan with a cover. Place into wind oven 1300 F. Coals are placed (red hot) above pan and Tartar. Open the windows of oven (ventilate), continue to heat above and below, slowly, until the fire becomes strong. The salt will melt and flow. Salt turns blue, slightly red and yellow.

Stir salts with a clean dry, spatula (warmed). When the above mentioned colors arise, the salts are opened up. Put the opened salts of Tartar in a clean, warm mortar. Place them dry in a reflux flask (digestion flask), pour on highly rectified spirit of wine, cover four fingers height. Close flask Hermetically. Place in a preheated sandbath. Increase the heat until the Spiritus Vini boils slightly. Same heat for three days (approximately 72 hours). Color of tincture will be ruby red. The smell will be as wine.

Filter the liquor (decant), add more Spiritus Vini to the salts until the Spiritus Vini has no more color after rotation. Albedo to Rubedo.

It was demonstrated by Michael Junius that if the Spiritus Vini That's used is not acuerd i.e. (NOT strong enough by reason of contamination of atmospheric moisture) that one can add Spirit of Tartari to it and the color (red) appears immediately.

## Tincture Tartari as Medicine:

This tincture acts as an anti depressant, or as a cleanser, and a tonic (a medicine that gradually restores the normal tone of organs in the body). It drives away melancholy. Strengthens and tones the liver and spleen. Can be used as a diuretic against blockages. Cures venereal disease. Purifies the blood of impurities. Dosage: 4 - 20 maximum drops in a wine or tea. Take for 40 days. Do not eat sour food or drinks while using it. 

The Results of ten years research...

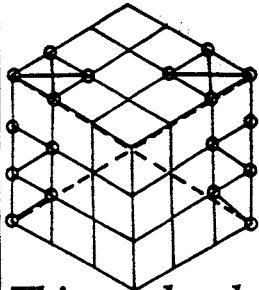

## The Cube of Space: The Container of Creation

a special workshop by Kevin Townley

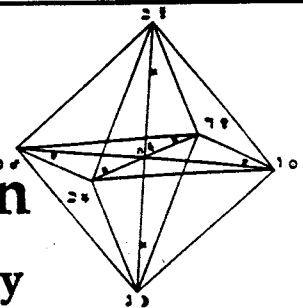

*This weekend workshop will take you through what is known about the Cube from the Sepher Yetzirah and the writings of Dr. Paul Foster Case, and then goes far beyond...*

The weekend will focus on the generation of the Cube of Space through geometry, the Magic Square of Saturn and the relationship of the Cube of Space to the Tree of Life. The placement of the Minor Arcana on the points of the Cube, and the Cube's relationship to the Macro and Microcosm, as it descends through the four worlds, will also be discussed.

Date: First weekend of May (tentative)  
Place: Chicago, Ill.

For more information including exact location and cost, write to: Kevin Townley c/o LPN-USA, Box 11218, Boulder, CO 80301.

# The LPN Seminar in Winfield, October 1992

*By Russell House*

It was a great pleasure for my wife, Sue, and I to be able to host the first LPN-USA seminar at our home in Winfield, Illinois on October of 1992. In May I had attended a seminar in Ontario, Canada, presented by five members of LPN France. The information and quality of the teachings were, to my experience, unique. It seemed most important to present these ideas to a larger group of students in the U.S. The invitation to give such a seminar was graciously accepted, and the dates and curriculum established.

The planning began at once on both sides of the Atlantic. Bill Van Doren, Kevin Townley and Karin DiGiacomo of LPN-USA provided much valuable advice and encouragement, and promoted the event to LPN members. Hans Nintzel generously used his extensive contacts to further promote the event. Patrice Maleze, who would be our translator, visited from Paris, and made it possible to make certain advance preparations for equipment and supplies. The planning was demanding, and it was fortunate that by the time that my reserves of energy had been depleted, my wife Sue was able to take over much of the remaining work. She did much to make the event as convenient and comfortable as possible.

The organization of our French LPN instructors was exceptional. The slides and other visual aids, and a well-coordinated team with expertise in various areas of the work, made it practical to cover numerous topics in a short time. Soon after their arrival, the equipment which had been brought with them from Paris was tested and final details were completed. All that remained was to discover which wines best complemented pizza. Incidentally, we found no bad wines.

The team from France included: Jean Dubuis, Founder and past President of LPN; Marc-Gerald Cibard, President of LPN; Yves Arbez, Vice-President of LPN; Etienne Cornaille, Treasurer of LPN; Lucille Gerbaut, Librarian and liaison to the English-speaking countries; and Patrice Maleze, translator. Jean-Michel Thuillet joined us on Sunday to assist in translations.

The theoretical program included an overview of the energies in Alchemy and Qabala, general rules for practical alchemical work, the secret fire, crystalline structures as lattices for energies, Mendeleev's table of the elements, and the black suns.

The practical aspects emphasized the metallic paths of the acetates, the path of Flamel and the work with butter of antimony. Jean Dubuis brought an effective electronically controlled furnace which he built to separate purified antimony sulfide from the crude ore. This method permits simultaneous capture of a red sulphur from the ore.

Etienne Cornaille demonstrated making a crucible

furnace using a simple cooking pot, refractory concrete, steel tubing and a large propane torch. Two such furnaces were used by the students to produce a lunar martial regulus of antimony. Yves Arbez demonstrated preparation of an amalgam using such a regulus and its distillation to capture an animated mercury, this being a key operation on the path of Flamel. Yves further explained the theoretical aspects of seeding mercury animated seven times in this manner, and subsequent incubation to prepare a white or red stone in the metallic kingdom. Some of the color plates from the Book of Abraham the Jew were shown.

Patrice Maleze gave an effective demonstration of preparation of butter of antimony from stibnite using chlorine gas generated from sea salt. This was necessarily conducted outside as were most of the processes, for the sake of safety. All were asked to sign a release of liability at the event, the purpose being to remind them that the processes were potentially hazardous, and to emphasize that each individual is responsible for their safety.

Marc-Gerald detailed the preparation of plant stones. This included both the 'natural' stones using their own salts, as well as 'synthetic' stones using chemical salts of a specific crystalline structure that have been animated using the water of deliquescence distilled from tartar salts. This was a topic of great interest, since all had been given portions of a synthetic stone of caraway prepared by Jean. Two years of incubation had given it a red-brown color. All who chose to do so took a bit of the stone with red wine. We were told that such stones can initiate inner contact with the energies at the sephirothic level of Hod. While a plant stone creates only temporary connections, these initiatic experiences are of value in our work. We were also given keys to interpretation of dreams according to their qabalistic correspondences, and the symbols of the four elements within these levels. Something of this is given in LPN Qabala lessons 25 and 31.

Lucille Gerbaut also took her turn in assisting with translations as required, and worked in many ways behind the scenes, verifying technical details for the lecturers, and improving the translation of the handouts before they were distributed. Each student went home with a sizeable packet of handouts, as a summary of each topic. The intent was to free students from unnecessary note-taking so that their minds might be free to concentrate on the ideas themselves.

On Sunday, Bill Van Doren and Kevin Townley explained the benefits of LPN membership, and invited non-members to join. There were a significant number of non-members in attendance, and we understand that some have since become members. We would like to welcome them, and to thank them for joining in our efforts. Ken Miller, editor of *The Stone*, brought the latest issue of the publication, hot from the press, which received a very favorable response.

On Sunday morning, Jean spoke on 'the Becoming of Man', which provided a perspective on the ultimate purpose of incarnation, on the so-called 'fall' of man from the absolute, and the path of return or reintegration. An explanation of sephirothic levels experienced in the descent and ascent were given, as well as the true identity of man as ELOHIM. Just prior to the close of the event, we were directed to sit on the lawn for an open forum, and Jean answered a broad range of questions. He reminded us that time was short, that even the most powerful qabalistic formulas were not sufficient to modify the flight schedule of Air France.

During preparation on the Monday before the seminar, I had suggested to Marc-Gerald that we rent large canopies to cover the patio and an area of the lawn, since much work had to be done outside. There had been some rainy days just before, that would have dampened the equipment, if not our spirits. Marc immediately announced, "No tents. It will not rain." He had waved aside any further comment on the matter, and so, there were no tents. The weather was wonderful. After the forum outdoors had ended, Marc pointed out a falling leaf. As I watched it, others began to fall, and the lawn was soon littered. There was a sudden coolness in the air. The event was over now.

Thanks to the efforts of Rick Grimes, the LPN now has in its archives a fairly complete record of the event on VHS. These are now being made available through the LPN for a most reasonable price. (See announcement elsewhere in this publication, ED.). While there are some minor technical flaws, which are, at the worst, distractions, the camera had the best seat in the house, and it is possible to peer closely into a red-hot crucible, to examine equipment in leisurely detail, and to review segments of the event at will. Rick has used titles and an index to make it a very useful reference tool. Rick has already worked out ways to remove these technical problems in anticipation of the next event.

While my own hopes for the seminar were very high from the very beginning, the event itself far exceeded my fondest dreams. The feeling of fellowship was wonderful. Alchemists tend to be, and perhaps must be, rugged individualists. From time to time I had wondered if this would express itself in tensions between personalities. Instead of focusing on that which makes us different, those who came focused on that which makes us alike - the love of learning, and the desire to progress on the path of reintegration. The event marked a new stage of development for LPN-USA, through the efforts of not just a few, but from the many. The increased involvement of individual members and the continued focus on that which makes us alike will strengthen our organization, and prepare us for even greater things.

✠

## "More than meets the eye.." at TRIAD.

✠

**\* HERBS \***

Over 500 bulk herbs, including the hard-to-find, as well as Ayurvedic and Chinese. Many tinctures and herbal blends available. Request free lists.

**SUNDEW (Drosera)**

Cut & Sifted,  
1 - 9 lbs \$19.95/lb  
10 - 20 lbs \$17.95/lb  
Over 20 lbs \$16.95/lb

**CARAWAY SEED**

whole, from Holland  
1 - 5 lbs \$4.50/lb  
6 - 10 lbs \$3.75/lb  
Over 10 Lbs \$2.50/lb

**HORSETAIL**

Cut & Sifted  
1 - 5 lbs \$7.00/lb  
6 - 10 lbs \$5.75/lb  
Over 10 lbs \$4.25/lb

**\* ESSENTIAL OILS \***

From rosemary to rose, from the common to the exotic, from commercial grades to the finest aromatherapy grades, we can

meet your specific needs. Oil diffusers and blends available. Custom blending service. List available.

**\* SUPPLIES AND ORES \***

Antimony ore, native sulphur and other materials available upon request. Let us quote on your specific needs. Triple-distilled mercury as low as \$7.99/lb.

**\* ALCHEMICAL T-SHIRTS \***

One of our most popular items is this line of fine shirts with designs from the ancient texts of the alchemists and mystics. Catalog sent upon request.

**\* BOOKS and TAPES \***

Over 10,000 books and tapes available. Topics include alchemy, qabala, astrology, healing, Western and Eastern spiritual paths. Rare reprints available, too. ALL TITLES AT 10% DISCOUNT. We also supply 'New Age,' classical and instructional music tapes, and many instructional videos.

**\* AND MORE..... \***

We carry homeopathic remedies, Bach flower remedies, incenses, Tarot decks, jewelry items, and more. There is so much more than meets the eye at TRIAD.

Send inquiries to:

**TRIAD**  
**125 West Front Street,**  
**Suite 275**  
**Wheaton, IL 60187**  
**USA**

*Sue and Russ House, proprietors.*

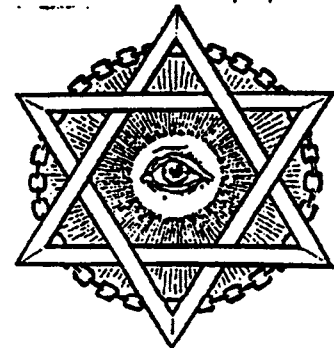



# THE WESTERN YOGA TRADITION

## (Taoist Yoga and Alchemy)

by P. R. Churcher

Most of the historical details of alchemy have been discussed in great detail. Joseph Needham, for example, has no doubt that Arabic alchemy was "deeply influenced" by Chinese alchemy and in turn "was largely responsible for setting the definitive alchemical style which lasted in European culture from about +1150 till the age of Libavius." There is even a possibility that the earlier Hellenistic alchemy, circa -100, was influenced by early contacts with China along the "Old Silk Road" beginning with the first Chinese explorer, Chang Chhien -140 to -110. Needham goes on to suggest that the "Tabla Smaragdina" is of Chinese origin.

But the cross cultural nature of alchemy is complicated by the fact that there is more than one alchemy. In China there is nei tan and wai tan. Whilst the latter was proto-chemical and worked on metals, the former was an internal process which worked on substances within the alchemist's own body, not least his mind, to produce the elixir of life. In the west we have proto-chemical alchemy and its search for the Philosopher's Stone and spiritual alchemy with its search for salvation and the elixir of life.

Wai tan is therefore assumed to be common in China, Arabia and the West. By contrast it is believed by Needham and others that nei tan or Taoist alchemy with its concern of physiology or macrobiotics is unique to China and has no parallel in the West. "We are now fully assured that it was entirely different, and that a radical distinction must be made between the two kinds of "alchemy" in the West and the two kinds of "alchemy" in China.

Needham's view is supported in "Ambix" by Richard Payne who states, "Chinese and European alchemy do not have a great deal in common, the difference in emphasis between psycho-physiological alchemy and psycho-spiritual alchemy is important in understanding the significance of symbols within each tradition."

We are familiar with the psychological interpretation of alchemy by Jung and the mystical element in alchemy with its association of Jesus Christ with the Stone etc. Indeed these aspects of alchemy are purely Western. However it seems strange that China should have influenced Western proto-chemical alchemy and yet have failed to influence the spiritual alchemy which grew up in the middle ages, for example Kunrath +1560 to +1605. A close examination of some of the literature of alchemy suggests that Payne and Needham are being too hasty in separating Chinese physiological alchemy from Western spiritual alchemy. What is of course different are the two cultures, where authoritarian repressiveness in the West meant that the greatest care had to be exercised in expressing essentially the same information.

But first Chinese physiological alchemy or Taoist alchemy has to be introduced for those unfamiliar with it.

## CHINESE PHYSIOLOGICAL ALCHEMY

Basically Chinese alchemy was concerned with physiology of mixing two energies, Yin and Yang (mercury and sulphur), of alchemy within the human body. It is now well reported that the basis of Yoga or union, in every religion, is conservation of the sexual energy/seed of the human body. Hence the requirement for celibacy that arises in many religions and cultures.

What Taoist physiological alchemy does is elaborates this process and makes it explicit. Whilst mystics in Western Catholicism may have achieved yoga through abstinence and meditation, the Taoist physiological alchemists understand the process behind the achievement.

The worm Eurobos has much in common with the Yin/Yang symbol, as the worm with its tail in its mouth it suggest unity and cyclicity. This symbol indicated the fundamental operation in Taoist Physiological alchemy that of the reverse flow of sexual energy from the testes/ovaries to the brain. This is similar in effect with the raising of Shakti up the spine in Indian Yoga. However if Indian Yoga is the "dry way", with its attendant dangers, then Taoist alchemy is the "wet way".

The reverse flow of sexual energy (see figure 1) is one of the stages in the process of revitalizing the components of the materia prima. After the Fall, the materia prima consists of mind (shen), vitality (chi) and reproductive essence (ching) which have to be returned to their original purity by incorporating external chi or air (through a breathing technique). Once purified these three "vitalities" they have to be recombined to produce the Huan Tan otherwise known as materia prima, the diamond body, or undifferentiated universe.

Firstly the Yin Chi from the Ching essence in the gonads turns to Yang Chi when it reaches the brain, it is then converted into shen or mind. As Eurobos indicates we have a cycle, the Yang falls, showers down the frontal path as Yin and returns to the gonads. This is the circulation of the Chi.

Earlier it was said that Yin and Yang have to combine. In our polarized world their only chance to unite appears to be centrally where Yang falls and Yin is drawn up. This point is called the "Yellow court" in the abdomen.

Shen or mind (Yang) plays an important role in the process. Yang (saliva) + shen (concentration) + Yin Chi from ching at the Yellow court appears to produce the immortal body.

When Yang is at its maximum Yin is born

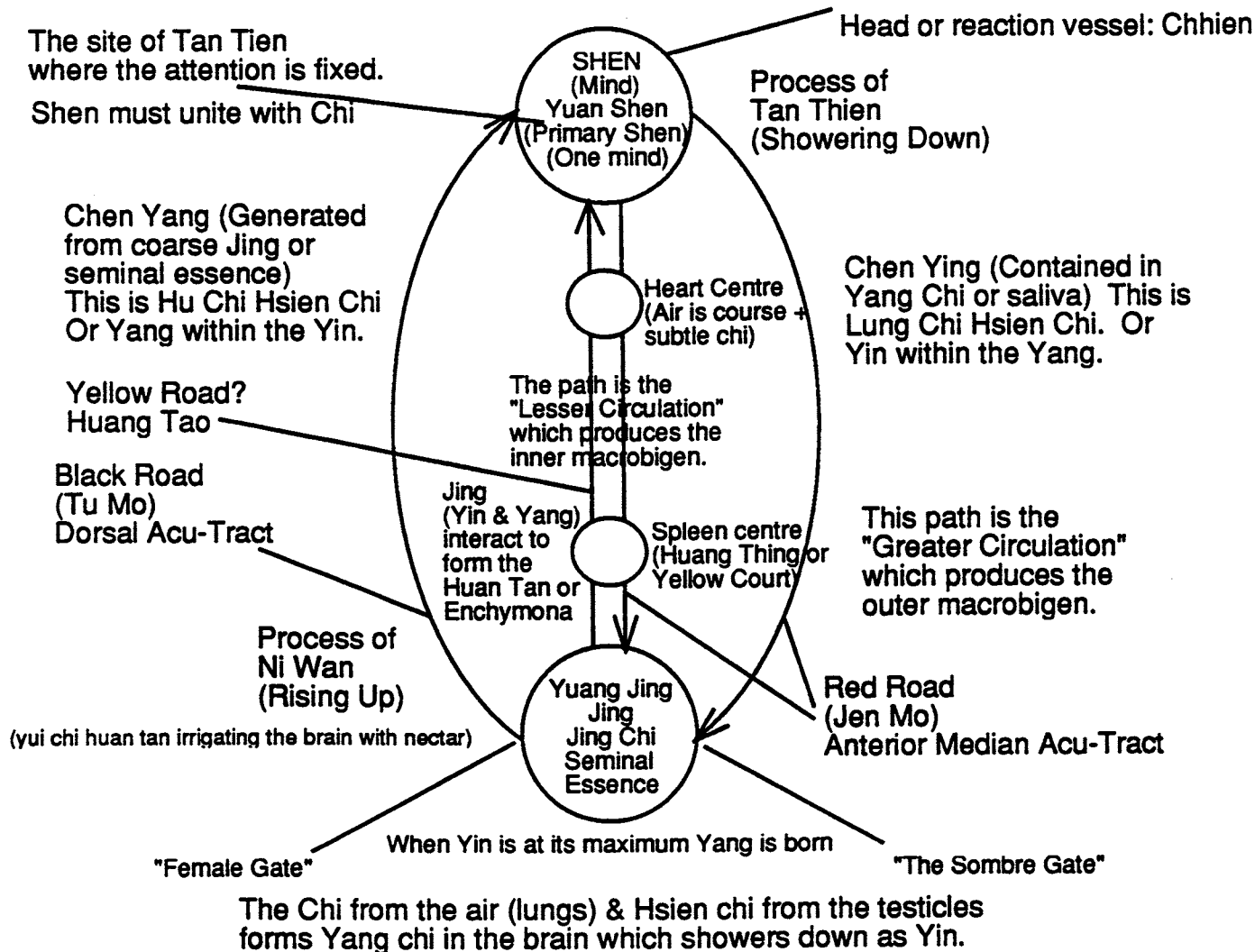

**The ninefold regeneration or circulation of the Chi**

**TAOIST PHYSIOLOGICAL ALCHEMY IN THE WEST**

Having ascertained that Taoist Physiological Alchemy is a set of procedures for achieving a definite objective is there any evidence that the same or similar processes have appeared in the West? Bearing in mind that we are looking at a different culture, with different terminology, styles and requirements.

Dionisus Andreas Freher, 1649-1728 on what appears to be purely metaphysical spiritual alchemy, entitled "Of the Analogy in the Process of the Philosophic Work, to the redemption of Man, through Jesus Christ, according to the Writings of Jacob Behmen." However in this piece are heavily veiled references which suggests the existence or knowledge of some of the fore-going processes. For example, "The serpent's sting, is the wrath fire, and the women's seed, the light and love fire: these two are in everything, the former predominated in

outward nature, by the fall, and therefore the latter must be raised up, and by its shining the wrath, must subdue and keep it under.

This requires translation into the same terminology used by the Taoist physiological alchemists so the correspondences can be weighed. The serpent's sting I take to be both Yang Chi and unpurified shen or mind. The women's seed I take to be Yin Chi or ching seminal essence. The notion that "these two are in everything" means of course sulphur and mercury (Yang and Yin) which confirms the earlier hypothesis that we are dealing with shen and ching. Where Freher states "the latter must be raised up" this is what we find, the Yin chi or ching is raised up through the process of Ni Tan. Where Freher stated that it must "subdue and keep it under" it is taken to mean the process of purification of the shen by means of the rising Chi.

Now the danger here is that I have elaborated the process of spiritual alchemy to the level of physiological alchemy and by doing so I have added a level of detail of which the original alchemists were unaware. If this is the case then Western spiritual alchemy was separate, if not then it was the same or similar.

Following this theme, Jacob Boehme, +1575 to +1624 was an important German mystic who employed alchemical imagery. As an influence on Freher it is to him we turn next.

In "The Signature of Things" he discussed sulphur and mercury (Yin and Yang) making the correct ascriptions "sul (sulphur) is the first principle of free will," "The second form in nature, in eternity is the Orb with the compunctive bitter essences: for there arises the essence, understand that with the perturbation, for the nothing is still without motion, but the perturbation makes the nothing active...the form is called Mercury."

While this is far from clear (Boehme is circumspect and also the translation appears to have lost some of the original sense), what it does indicate is an association of sulphur (Yang) with mind which is different from a second "bitter essence" being mercury.

Boehme continues "For the serpent's poisonous earthly property was manifest and stirred up in man: therefore when God's word did pity the corruption of man, and did again embrace him, he said "The seed of the woman shall bruise the serpent's head"...Herein now lie the Philosopher's Stone (to know) how the seed of the woman bruises the serpent's head."

This is a little clearer and introduces at a decorous distance the required sexual imagery (noting that Boehme is clearly talking about a process within one individual and not between two). The Philosopher's Stone is the union of sulphur and mercury as we know from chemical alchemy and here, as in physiological alchemy, the union is achieved by the seminal essence (seed) bruising the serpent's head (refining the coarse shen/mind). This compares with the slightly more poetic and contemporary Chinese saying

"irrigating the brain with nectar". Later on Boehme also refers to the "baptism" with the "inward water", even when the mercury begins to hunger after divine essence, and does his first miracle, and turns water into wine.. This conversion of water into wine must surely correspond again to the conversion of Ching to Chi.

In the following quotation Boehme appears to elaborate on the process by equating the male with fire and the female with water (as in the Chinese) making it even clearer that he is talking about a physical process: - "Every creature keeps in its generation and propagation to its own kind: the male to the female, and the female to the male; Now God said to Adam and Eve after the Fall; "the seed of the women shall bruise the serpent's head" he said not (the seed) of the man; Herein lies the baptism of nature: The male has the fire spirit and the female the water spirit to the tincture". Here again the "baptism of nature" corresponds to "irrigating the brain with nectar".

The second part of the Greater Circulation involves the frontal path. Boehme refers to what could be the "showering down" in figure 1 above where Yang travels down the frontal path back to the testes. As follows: - "the heavenly tincture, must bruise the head of the serpent, viz. the poisonous mercury, in the property of death, and change his poison into wine, and then the virgin receives the seed of the bridegroom, and not before." Here the seed of the bridegroom must correspond to Tang saliva.

We are sure that Boehme is still referring to an individual rather than a couple when he goes on to say "Therefore the artist must beware, and keep himself from such anger, and yet must prepare a cross for this married couple". What is the cross? Could this refer to a location like the "Yellow Court"? Boehme goes on to say "so they both in their marriage bed of love might lift up their desire....they shall beget such a child, which they...shall nourish in the belly till it be ripe." and later "he need only make their bed ready, they will warm it well enough themselves." The child here must of course correspond to the Huan Tan and the warming of the bed referring to the heat generated by fusion.

Therefore Boehme seems to describe in his own cultural and conceptual framework the main elements of physiological alchemy. Mercury (Yin Chi), Sulphur (Yang Chi and Shen), the child (Huan Tan), the seed of the bridegroom (Yang Chi), the bedchamber (Yellow Court) and the baptism of nature (irrigating the brain with nectar).

Boehme in translation is rather wordy and repetitive, the nuggets are therefore scattered. His writings are therefore not absolute evidence because of the degree of interpretation required, further research is necessary.

## CONCLUSION

Even if Boehme and Freher weren't expounding physiological alchemy there spiritual alchemy appears to be a lot closer to Taoist alchemy than Needham and

Payne suggest. It is important to ascertain whether physiological alchemy was practiced in the West, if so it unifies the foundations of Chinese, Indian and European spiritual traditions. Further it shows an existence of a practical spiritual tradition, on the par with Taoism and Yoga, in the West that predates both Rosicrucianism and Freemasonry.

Finally Needham reports that in 1880 Martin wrote "In the Chinese system there are two processes, the one inward and spiritual (nei tan), the other outward and material (wai tan). To obtain the greater elixir, involving the attainment of immortality, both must be combined."

If Martin is correct, than all chemical alchemists need to consider physiological alchemy as a complementary process on the path to Western Yoga.



## Corrections to The Stone, issue number six (Fall 1992)

*From A.M. House comes two corrections to his article A Philosophical Dose of Alchemical Keys:*

1. Cerrusite is **NOT** one of the ingredients in the Flamel process, the references to it should be disregarded.

2. The first two sentences of the last paragraph on page ten should read: The tree of life diagram (traditional 10 sephiroth) was used throughout the seminar to illustrate the levels and gave dimension to the many references made to portray the inner worlds. "Dreams," we were told "contact higher levels of energy."

*From Jake Davidson regarding the Enochian article:*

The first endnote on page seventeen is misleading. While some of the Golden Dawn Enochian material came from Harley 6482, the bulk of their material (in liber H) came from Sloane 307, which unfortunately has never been published. The author of Sloane 307 apparently never saw Dee's tables because he misunderstood the use of the Black Cross in making Spirit names; and the exact same errors appear in Liber H. And of course any book detailing Enochian Magic based on Golden Dawn principles, especially the painfully inadequate books by Gerald Schueler, do not reflect Dee's actual instruction.

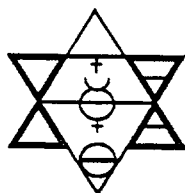

## About The Stone

The Stone is published three times a year, in the Spring, Summer, and Fall, primarily for the benefit of the membership of LPN-USA. We hope to get member's feedback regarding what they would like to see in it. Articles, photographs, drawings, letters, and comments from members or others are solicited for submission to the Editor for evaluation. Submissions and advertising should be sent to The Stone c/o Ken Miller, 405 West Washington Street, Suite 314, San Diego, CA. 92103-1996.

## Advertising

The Stone is now accepting advertising, both display and classified ads. Rates are as follows: Full page: \$100; Half page: \$55; Quarter page: \$30; Classified ads are \$0.05 per word. Ads must be camera ready. Non camera ready ads can be typeset at additional charge. For more information call or write the Editor, Ken Miller, at 405 West Washington Street, Suite 314, San Diego, CA. 92103-1996. 24 hour message line: (619) 491-4500. Long distance calls returned collect.

## Subscription to The Stone

The Stone is included in the cost of the lessons. Non-members may subscribe at the rate of \$20 per year. Subscription requests should be sent to the administrative headquarters: LPN-USA, P.O. Box 11218, Boulder, CO. 80301.

### Stone of the Wise

What jewel is that to be denied  
Whose lustre doth cease not to  
shine  
Which turns baser metals into  
gold  
And melts the hearts of all  
mankind?

Jim Dery

# \* Book Reviews \*

## The Minor Opus

by John H. Reid

\$35.00; available from the author, P.O. Box 223, Pelham N.Y. 10803; 1993.

Modern books on alchemy are fairly rare, so it is always a pleasure when someone publishes the fruits of their labor. Books of this sort are hard to review because I haven't taken the time to duplicate the lab work, all I can do is offer a survey of the text. Mr. Reid's book presents instruction, as the title suggests, on the plant work; covering beginning herbal tinctures on up to the making of a plant stone. This is all the more remarkable as the author was largely self-taught.

The book is divided into two sections, Theory and Practice. I found the first section is weak, the explanations of salt, sulphur, and mercury were very superficial. The descriptions of the elements were somewhat better. The best was the astrological instruction on how to tap planetary energies, and appears to be a good synthesis of material.

The Practice section includes several good lab tips, good instructions on making spagyric extracts, tinctures, and essences. The chapter on the Archæus of water includes Mr. Reid's pH readings of all the component parts; the first time I've ever seen that information in print, and I believe it provides clues to different possible uses of the water.

Unfortunately, just when the book is about to get really interesting, revealing the technique for the plant stone, Mr. Reid writes, "I could, I suppose write the process out in plain english but that would be depriving you of the joys of self discovery." In other words, his description of the process imitates the texts of old, leaving the reader to ponder his use of several symbolic terms. Some people may enjoy this approach but I would have preferred a straight description. On the other hand, the several color pictures of the process will certainly be of help to those souls who try to duplicate this work.

The bottom line: this book is not for beginners, at least not the plant stone work. It will be far more useful if you have some experience both in the lab and with some of the classical texts of alchemy. Mr. Reid estimates \$3000+ to set up a lab to do this work; a beginner should keep this in mind. I do recommend it to the seasoned alchemist because so many of us have not completed the work in the plant kingdom, and while the text is sometimes vague, it is useful to see the path another has taken and learn from that. I hope this text inspires other alchemists to publish their fruits of labor; we are all enriched when one allows us to learn from their experiences. We should thank Mr. Reid for sharing his hard won results with us all.

## Call Upon My Name: The Path of Ma'aseh Merkava

by Rabbi Ariel Bar-Tzadok

Available from Yeshivat Benei N'vi'im, P.O. box 678, Fairfield, Iowa 52556. 1992.

This book, to my knowledge, is the first in English to really give practical instruction in the Merkava tradition; the tradition of Jewish ecstatic meditation. This is the meditative path through which one can come to know the Creator.

The book is packed with information and will require a couple of readings to fully digest it all, but the practices are laid out step by step, beginning with simple contemplations on YHWH (the Hebrew letters of this name of God) continuing through sophisticated permutations of holy names. All designed to help you achieve an ecstatic union with the One.

I recommend this book highly if you are looking for a good adjunct to your more intellectual Kabbalistic studies. Collectors should be aware that much of the material has never been translated into English before now. The purchase price of the book also allows you to consult with the author if you have any questions regarding the technique.

## The Flying Sorcerer

by Francis X. King

Published by Madrake, P.O. box 250, Oxford OX1 1AP, Britain. Available in this country from Samuel Weiser. 1992.

This slim volume (76 pages), gives an account of Francis Barrett and presents some previously unpublished material by him, in addition to providing a fairly critical analysis of his text. Barrett is the author of *The Magus*, that classic of plagiarized magic and alchemy, originally published in 1801.

I found this book very readable and interesting, perhaps because I was 13 when I first read *The Magus* (and didn't make much sense out of it!). Unfortunately, it is far short of a comprehensive biography, too little is known of Barrett. But it does paint a good picture of the man and the "school" he formed to teach magic. The biggest surprise may be the fact he experimented with balloon flight! The book jacket reads "Francis Barrett (was) a man who lived on the frontier of technology, both in terms of inner landscape and his pioneering experiments in balloon flight."

I recommend this book to all who are interested in Barrett or *The Magus*, (not to be confused with the John Fowles work of fiction bearing the same name), a man whose influence in occultism continues to be felt to this day.



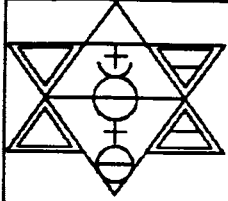

# The Stone

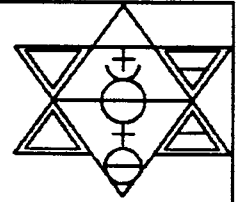

*Journal of The Philosophers of Nature*

Issue Number Eight

Late Summer, 1993

## Stone Crumbles To Dust....

*phoenix arises with broken wing*

Had life's events unfolded as I had intended, you would now be reading a (hopefully) interesting editorial on the connection between the proper mind state and lab work. As things stand now, I must humbly ask you to attune to the Aethers to receive that article because the computer that is used to produce The Stone had its hard disk crash several days ago. Foolishly I had not backed up the near-finished issue and lost it all. The lesson here is to always and frequently back up your data. And if a parallel may be drawn to lab work, perhaps it is to always think "safety first."

As a consequence, the issue had to be redone from scratch, and due to the severe time constraints, as we wanted to get this issue out a month before the big seminar in St. Charles, Ill. (which you'll read about in this issue - if you haven't already registered I urge you to do so today, as space is limited and it promises to be the alchemical event of the year) I must apologize to all the loyal readers if this issue seems a bit "unpolished" and lacks all the nifty pictures we usually include. The typical issue has all the pictures scanned in and laser printed; this time I had to cut and paste and settle for near laser quality output. Enough of my problems, I hope you enjoy the issue and please provide any feedback, I hear from so few of you. We're trying to go quarterly but need more submissions; so send your articles, pictures, poems, and letters to the address listed on the last page.

On a lighter note, the organization is now officially called "The Philosophers of Nature." Although you will still see "LPN-USA" used in different places in this issue. As far as I know no one has addressed this burning question: What acronym do we now use and how do we pronounce it? "LPN-USA" had such a great ring to it. Are we TPON (The Philosophers of Nature) or just PON? And do we pronounce it "Tea-Pea-Oh-En" or "Tea-pahn?" On that note, I sincerely hope you enjoy issue number eight of The Stone.



### In This issue...

Stone Crumbles to Dust; by K. Miller.....	Pg.1
Further Comments on Chinese Alchemy; by Tim Scott.....	Pg.2
Lab Notes: Spagyric Month 9; by Paul W. Baines.....	Pg.4
Book Review; by K. Miller.....	Pg.6
The Spagyric Technique; by Robert A. Bartlett.....	Pg.8
The Alchemy of Politics; by P.R. Churcher.....	Pg.15
Path of Flamel: French Research Update.....	Pg.17
Alchemy & Qabala Workshop: Five days in September by Russ House.....	Pg.18
New Research Projects for Americans; by Russ House.....	Pg.20
New Courses under Development; by Bill Van Doren.....	Pg.21

### **The Stone, Issue Number Eight, Late Summer 1993.**

Published tri-annually by The Philosophers of Nature. Editor: Ken Miller; Executive Director: Bill Van Doren; Good Intentions: Kevin Townley. Copyright 1993.

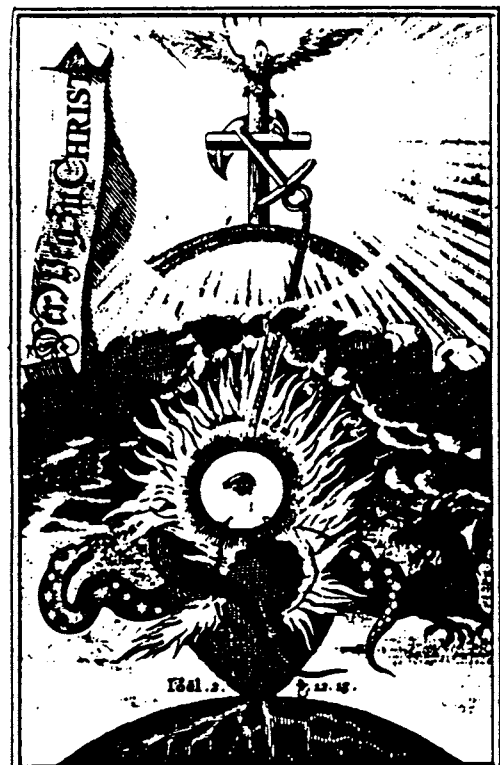

# Further Comments on Chinese Alchemy

by T.P. Scott

P. R. Churcher's article (The Stone, # 7) on some parallels between Chinese and European alchemy was very fascinating to me. I'd like to add some of my own thoughts and some references to books in English the interested student can pursue.

In this discussion, I posit for convenience an arbitrary distinction of "Lab" and "internal" alchemy. I fully realize that this is a much more complex issue than such a simplistic division implies but it may help to keep this essay from getting too unwieldy. Also, I refer to "Taoist" rather than "Chinese" alchemy although they are apparently synonymous. As far as I can tell, neither the Confucian, Mohist nor Buddhist strains of mysticism and philosophy in China produced what we think of as alchemy. Finally, let me emphasize that every sentence that appears here should be prefaced with "In my opinion," unless it is an attribution to another's work (in which case it should read "In so-and-so's opinion...") and so forth on into the infinite regress of nested disclaimers.

As anyone who has studied them knows, European alchemical writers are famous/notorious for writing in an extremely allegorical/mystical way. Some authors use allegorical concepts to mask laboratory operations, and I think that there may be those who use laboratory concepts to mask internal operations. Similarly, in Taoist alchemy, there are certain terms whose "real" meanings are certainly not the same as the literal ones. As an example, note the names of acupuncture points. Many of these are based on symbolism: for instance yongquan (K-1), "bubbling well" or "gushing spring", or "Qihu" (S-13) "Qi's Household" or "Qi's Residence."

I trust it's clear to everyone reading this that "dual-cultivation" or other techniques involving sexual practices have nothing to do with "great sex" and everything to do with alchemy. Unfortunately, due to the persistent popularity of such writers as Aleister Crowley, and the numerous reprints of books like "The Tao of Sex" and "Sexual Secrets" there is still tremendous misinformation about the highest expression of these techniques. Imagine, then, the difficulty of someone writing in the place and time of Thomas Vaughn, expressing these concepts. A. E. Waite at least does a careful analysis of his writings.

Jacob Boehme is one of many European writers considered "alchemical" who are clearly writing in an allegorical/mystical form. But I think that Thomas Vaughn is at least as good an example of this. In fact, in J. C. Cooper's Chinese Alchemy is quoted Arthur Waley, "Whereas in reading the works of western alchemists one constantly suspects that the quest with which they are concerned is a purely spiritual one; that they are using romantic phraseology merely to poeticize religious experience, in China there is no such distinction. Alchemy becomes there openly and avowedly what it almost seems to be in the works of Boehme or Thomas Vaughn." I agree that Thomas Vaughn is clearly one of the mystical writers who is most obviously using alchemical symbolism for non-laboratory concepts. I find this interesting example in his Anthroposia Theomagia: "The sun and the moon are two active principles..."<sup>1</sup>

P. R. Churcher does a good job of summarizing the salient points of Taoist yogic alchemy (for lack of a better term) so I will not repeat it here.

In a recent article in "Qi" magazine (Spring 1993) entitled "...the Allegory of Chinese Alchemy" the author contends that ancient Taoist alchemical writings are prima facie incomprehensible. This much can be argued, but then she goes further to practically state that the "correct" interpretation is that of Liu I-ming, a Taoist of the northern school who lived in the late 17th and early 18th Centuries. In my opinion, Liu's interpretation is only one of many and bears a strong devotional Buddhist stamp. I think the analogy is to those alchemical writers who find in alchemy only metaphors for spiritual development, or psychologists like Jung who could only make sense of them as treatises on mystical psychological states. As a counterpoise to this, read Immortal Sisters, especially the commentary on the poems of Sun Bu-er by Cheng, Ying-ning.

In my opinion, to prefer this "spiritual", incorporeal approach to an "occult" or "magical" one is simply a matter of preference, but with a large difference: the entire structure of traditional Chinese medicine, qigong, taijiquan, martial arts and internal cultivation depend on a very practical and material physical and somatic interpretation of alchemical concepts. If qi, shen and jing (the Taoist "Three Treasures") are simply terms for various spiritual states, and the circulation of qi is simply a meditative practice, then not only are advanced taijiquan and qigong students deluded, but the entire structure of traditional Chinese medicine (with its channels, organ associations and concentration on the movement of qi) is merely a superstitious remnant. I'm sorry, but my experience with practitioners of all these things convince me that the Cleary interpretation is, if not wrong, quite limited in its potential.

Immortal Sisters: Here Cleary's commentary is (thankfully) at a minimum. Most of the book consists of poetry by famous Taoist women with commentary by 20th Century scholar Cheng, Ying-ning. In the



commentary Yingning several times says things like: "There is another meaning to such-and-such which I am not at liberty to discuss/is not relevant in this place/would take up too much room, etc." I think that what he is trying to do there is not just to be coy but to lead the reader into his own researches. Cleary does not expand on any of these comments, and, I think, for good reason: it is outside his area of understanding. When he does comment, it is making what are sometimes stretching comparisons to Buddhism which I maintain misses the point that some of the poets are trying to make. The entire book has an odd odor to me, considering the diametrically opposed viewpoints of Cleary and the commentator he translates (Cheng). Incidentally, it is also interesting for this scholarly work to again have no bibliography, no index, no Chinese word glossary. In one place, the alchemist Chang Po-tan is referred to by the Pinyin transliteration Zhang Boduan. This may be simply an editing error, but I can't get over the feeling that the work was thrown together by Cleary, perhaps from sources he drew from different places.

We next turn to *The Secret of the Golden Flower*: This text is first known to most via Richard Wilhelm's translation, which has fortunately been reprinted many times and is, I believe, currently in print. (It is relatively available even when out of print.) In Cleary's edition, he is vehemently anti-Wilhelm, coming right out and saying that Wilhelm would not have been able to understand the concepts presented therein. However, Wilhelm does state that he had the assistance of Chinese specialists in the preparation of his translation, although it is certainly possible that said specialists misinterpret or misunderstand the material.

However, Cleary's treatment of this work is suspiciously personal. For instance, he gives no references, no glosses, no bibliography except for his own works, or even a single Chinese word in this book. While condemning Wilhelm for using a corrupt recensions of a fragmentary text, he simply mentions that "it was possible to find a good text in the Taoist canon" to work from. Oh yeah? You mean there is only one valid edition of this work? If so, what is its name, author and date, please? It is intensely frustrating about Cleary that he neglects (refuses?) to give references, bibliography or use any Chinese words whatever. In *Golden Flower* he even stops using "Tao" and instead uses something like "The way." This is intellectually very dishonest in my opinion, as well as using "vitality, spirit and essence" for "qi, shen and jing". Cooper, Yang, and others often spend several pages explaining the nuances and meanings of these words; whereas Cleary simply picks English words to approximate them and sails blithely on.

My personal impression is that he is condescending to his audience, several times implying that Westerners don't have a clue. He may feel that references to Chinese works are extraneous since his readers probably could neither find nor understand them anyhow. Either that, or he feels his translations and notes are so definitive that no references are needed; rather future scholars will reference him.

Either approach I find somehow distasteful or even non-Taoist.

DISCLAIMER: I must state immediately that my opinions and conclusions are unsullied by formal Sinological scholarship. My sources are: (1) a certain amount of reasoning from the material presented (2) some direct teaching (3) personal experiences (4) discussions with other interested and well-versed parties

## REFERENCES

- Chia, Mantak. Various popular works.  
 Chkashige. *Oriental Alchemy*.  
 Cleary, Thomas [tr. & ed.] *Immortal Sisters*.  
 Cleary, Thomas [tr. & ed.] *The Secret of the Golden Flower*.  
 Cooper, Jean C. *Chinese Alchemy*.  
 Luk, Charles (Lu Kuan Yu) *Taoist Yoga*.  
 Sivin, Nathan. *Notes on Chinese Alchemy*.  
 Wilhelm, Richard [tr. & ed.] *The Secret of the Golden Flower*.  
 Yang, Jwing-Ming. *The Root of Chinese Chi Kung*.  
 Waley, Arthur. *Notes on Chinese Alchemy*. (Waley is several times referred to by Cooper, I have not been able to further identify this work.)  
 Ware, James. *Alchemy in the China of 320 A.D.*

## FOOTNOTES

- 1 The Works of Thomas Vaughn; p. 29.

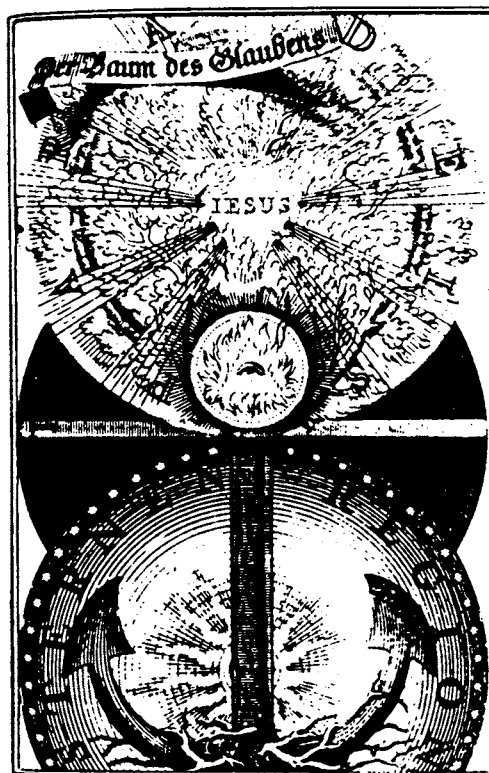

# Lab Notes: Spagyrics Month 9

by Paul W. Baines

## EXPERIMENT 1

11/3/89. 500ml of pure alcohol, previously macerated over anhydrous pot. carb. for 24 hours, was distilled under vacuum via a fractioning column. A quantity of Herba Equisetum was pulverized by hand, passed through a sieve and dried to constant weight over a water bath. This was packed into a cellulose thimble and the Soxhlet apparatus set up.

11/4/89. Saturday after new moon. The extractor was turned on so as to commence extraction during the first planetary hour of Saturn. After completion of extraction, the contents of the thimble were ignited and later calcined. The water soluble salts were leached out with Aq. Dest., filtered and recovered with slow evaporation. The salt solution showed a neutral to slightly alkaline pH, unlike the salts of other plants which gave a strongly alkaline reaction. I have concluded that the salt of Equisetum consists largely of soluble silica in the form of silicic acid. The salt was purified by the Solve et Coagula method 4-5 times until a white, completely soluble salt was obtained.

I have found that, almost invariably, on redissolving vegetable salts a certain amount remains insoluble despite agitation and heating. I have not accounted for this phenomenon. I reiterate the Solve et Coagula until the salt dissolves completely and gives a clear colorless solution. Sometimes a yellow tinge has been observed in which case a further calcination is carried out. This usually results in the salt blackening which is not due to contamination since the dish is covered with a lid. In redissolving this and filtering, a clear solution is obtained whilst black particles (carbon?) remain on the paper. This happened particularly in the salt of caraway.

It was intended to use the Equisetum to carry out one of the experiments outlined in Lesson 17 but due to the minute amount of salt obtained and its unusual character it was decided to proceed and make it into one of the seven daily planetary elixirs. To this end the tincture was poured onto the salt and left to macerate for a week prior to the first distillation.

## EXPERIMENT 2

I have found that the Soxhlet process has several disadvantages with respect to plant spagyrics. On using an extractor with a 60ml siphoning capacity, the amount of material used at any one time yields only a minute quantity of soluble salt. My other extractor of siphoning capacity 600ml will produce 750ml tincture which is a very large amount in relation to the quantity of salt that would be obtained from the exhausted material. I had thought of using several thimblefuls of dried material in the 60ml extractor but this would mean exposing the sulphur to long periods of heating and possibly overloading the menstruum. As it is, no matter how carefully one heats, a ring forms in the flask, indicating some damage to the sulphur. Junius states that the Soxhlet process should not be applied to frequently in plant spagyrics since the heat can cause a loss of valuable principles.

Having meditated upon this matter I propose the following method which requires the minimum of heat and narrows the gap between the respective volumes of tincture and salt. The method consists of a modification of the percolation or displacement method employed in botanical pharmacy. The following relevant passages are quoted from "Essentials of Pharmacy", London College, 1914:-

"When properly carried out, all the advantages of maceration are obtained, and, moreover, the drug cannot retain any portion of the menstruum containing much extractive, since the strong solution obtained by the first action of the menstruum is displaced by the weaker solution which passes through after.

"The degree of saturation of the percolate will vary with the height of the column of drug in the percolator compared with its width; the height should be at least six times the width.

"A cylindrical percolator is indicated for strongly alcoholic mentrua, as the swelling of drugs with these is negligible. If a very strong percolate is required, a very narrow cylindrical percolator is to be preferred, so that a small quantity of menstruum will pass through a relatively large amount of drug. A wide cylindrical percolator is to be avoided, since the menstruum takes a tapering direction as it descends and the drug at the bottom near the sides is hardly acted upon by the solvent. The wider the percolator the more drug is left unexhausted.

"The finer the powder the more ready will be the solution, but care should be taken to avoid too fine a powder or blocking of the percolator will result.

"The tighter the packing the greater will be the saturation of the finished product, since longer time will necessarily be taken by the menstruum to percolate through. Blocking of the percolator will be likely if packed too tightly."

For this exercise 100g of powdered nutmeg (*Myristica fragrans*) was used to produce 100ml of 1:1 tincture (fluid extract). Apparatus used was that for elution chromatography. METHOD: A chromatograph column 25 x 500mm was used. The bottom end was plugged with cotton wool and 100g of dry nutmeg powder was introduced at the top, being packed by means of a glass tamper. Slurrying the powder first with the menstruum proved unsatisfactory as this completely blocked the flow of menstruum through such a narrow percolator. A stopcock adaptor was attached to the bottom end of the column and the whole fitted into the neck of a filter flask. To the top of the column was attached a 500ml dropping funnel containing highly rectified spirit. During the time the funnel stopcock was open, a calcium chloride tube was fitted into the neck to preclude atmospheric moisture. At all other times the funnel was stoppered. Alcohol was allowed to run onto the nutmeg powder from the funnel until it began to run from the bottom of the column. The bottom stopcock was closed and about 2cm. of menstruum allowed to cover the drug. This operation was done at sunrise on Thursday, November 9. The nutmeg was allowed to macerate for 24 hours.

The next day the bottom tap was opened and percolation allowed to proceed. After several hours it was noted that the menstruum was barely moving (this was due to a vacuum at the top of the column). It was decided to attach the vacuum pump to the filter flask to facilitate percolation. As the percolate ran into the flask a steady flow of alcohol was maintained to keep the powder covered. When 80ml of percolate was obtained the process was stopped and the percolate reserved. Percolation was continued until the material was exhausted (evident when the menstruum ran clear).

The alcohol was recovered from the second percolate by distillation until 20ml of tincture remained in the flask. This was added to the reserved portion thus making it up to 100ml. By using this method only a small portion of the sulphur is subjected to heat, the majority of it being contained in the first percolate. Distillation under reduced pressure would be less damaging to the latter portion of sulphur. Should it have been desired to produce 200ml of tincture, the process could be repeated with a further 100g of powdered material using the second portion of percolate to make the first portion of batch 2 (repercolation).

The exhausted drug was removed from the column and ignited in a porcelain dish. It burned vigorously as though mixed with nitre. The ashes were calcined and extracted with distilled rainwater in a Soxhlet apparatus. The salts were retrieved and purified. It was decided to try a second extraction using glacial acetic acid, a procedure new to me. The apparatus was heated cautiously in an oil bath containing liquid paraffin. The top of the condenser

was attached via tubing to a wash bottle containing 5% soda solution. Acetic acid vapour began to enter the extractor chamber when the oil bath temperature registered 150C. The process was extremely slow and the apparatus was prone to cooling easily. It was a cold day and the window had been left open as an added precaution. Although there was no smell of acetic acid I did note some eye irritation. Putting safety first I was not prepared to be too liberal with the heat and decided to abort the operation. Some material had been extracted by the acid as I had previously primed the extractor two thirds full. Having noted how well the acid was refluxing in the flask I decided to repeat the operation using a modified Myer's arrangement.

Some fine, strong threads were passed through the upper portion of the Soxhlet thimble so that it could be suspended over the acetic acid in the boiling flask. The threads were held fast by the cone of the reflux condenser. The whole lot was set up to reflux for several hours, the acid vapour permeating the thimble. At the end of the process the glacial acetic acid had become white and cloudy with a ring of gel-like material around the surface of the liquid. The acid had become quite viscous, the extracted material having formed a gel rather than a solution. An attempt was made to recover the acid by distillation but the operation was aborted as being considered to be dangerous and ineffective. Although using a squat flask, the vapour was unable to reach the stillhead, the temperature at the outlet registering no more than 60C whilst the liquid itself was at boiling point. The liquid did not boil evenly but with violent bursts which displaced the thermometer from the stillhead. It is doubtful if boiling stones would have prevented this. The liquid is currently in a flask and it has been noted that a fine, insoluble haze is settling out. I am at present attempting to find some other method whereby the extracted salt can be separated. I would imagine that the slat of an acetic acid extraction consists mainly of calcium acetate.

### EXPERIMENT 3

This is a continuation of Month 7 work. The ash from the incinerated caraway seeds was leached out in a Soxhlet extractor. The purification procedure was carried out six times before a clean, white, completely soluble salt was obtained. It did require a further calcination which rendered the salt blackish. Further solution and filtration cleared the problem. Since the salt was leached out with water from the oil extraction and fermentation it seems likely that some traces of sulphur still remained.

The ash from the incineration of the fixed sulphur was also leached out. It was noted that a greater volume of soluble salt was obtained which was rendered pure after only two solutions and filtrations.

The alcohol obtained from the first distillation of the fermented must was rectified but was discovered to be mostly ethyl acetate. Since the fermenting must had become contaminated with acetifying organisms it follows that the ethyl acetate was produced along with acetic acid.

Since the B.P. of ethyl acetate is 77.5C it would be difficult to isolate it from alcohol. It does not appear to distill over as readily as alcohol. Ethyl acetate can be identified by its fruity odor and the fact that a mixture of ethyl acetate and water can be separated by saturating the solution with salt.

This is an interesting substance, being a compound formed of the volatile spirit and fixed acetic acid. It seems very likely that the ancients must have isolated ethyl acetate from the acetified wine but no obvious mention has been made of it - to my knowledge.

QUESTION: What, if any, is the spagyric/alchemical significance of ethyl acetate?

## AN OBSERVATION:

In the first experiment with Melissa we mix the exhausted marc with an equal quantity of dried untreated herb prior to incineration. This is done in order to replace those elements removed during the extraction with brandy. However, in later work (Lesson 17, page 4) we are told that the feces should not contain any product soluble in alcohol. This implies that the feces should not be mixed with untreated material as the latter would contain alcohol soluble products.

Re: Month 8. No lab work was carried out during this time as I was working intensively on the house. The lab is almost finished and only awaits to have water and drainage plumbed in. The Temple, a single room at the top of the house, has been prepared. We still have to soundproof the window and we have a craftsman who is making us a double cube altar from solid pine. We can at least use the room for the Pentagram ritual and meditation as it stands. The work on Quabalah is being supplemented by the Golden Dawn material (Israel Regardie) and Franz Bardon's "Initiation into Hermetics." 

## Book Review

### The Cube Of Space, by Kevin Townley

No, it's not another book rehashing Golden Dawn or Crowlian material; rather it represents refreshing original research on what is probably the least talked about and perhaps the most important glyph in Kabbalah: The Cube of Space. One of the source works of Kabbalah, as most readers of The Stone will know, is the Sefer Yetzirah, the "Book of Creation." This text explains in mystical detail how Yah (the Lord of Hosts, King of the Universe) formed Creation "with text, with number, and with communication" by using these elements to manifest a container, a cube to hold the universe. The text basically reveals, in difficult and often terse words, how God created the Macrocosm, putting in each direction a Hebrew letter. And you would think that as important a symbol as this is, it would receive some attention and study from occultists, much like the Tree of Life has in innumerable texts. Sadly this has not been the case; at least not until now. Kevin Townley's recently published *The Cube of Space: Container of Creation* admirably fills the gap.

This text goes into great detail explicating the Cube, beginning with an overview of its basic symbolism, relating the Cube to salt, Masonic symbolism, and the relation of involution/evolution to creation. Understanding the geometry involved, the currents of creative energy and their relationship, and the interconnections with the Tree of Life are all covered in some detail.

The second half of the book considers the meaning of the Tarot and the Cube, using the Golden Dawn / BOTA Hebrew & astrological attributes of the cards. As there is a Hebrew letter attributed to each line and face, one can place the Tarot keys on the Cube and gain insight into the energetic functions of that place; further, Kevin has worked out placing the minor arcana on the Cube, and goes into great detail explaining what this all means, and has practical value to anyone who works meditatively with Tarot.

One caveat, the table of contents is as good as useless, listing merely "Chapter 1....page X." This is frustrating because every chapter is titled, and each chapter usually has several subheadings, all of which would have been very useful in the Table of Contents. The index partially made up for this inconvenience, but it is still frustrating when you want to review specific subject areas.

At this point the reader may be saying, "So what? Of what practical value will this book have for me?" Aside from saving you years of having to correlate the information on your own, the literal keys to creation are given to you. In other words, if you are dissatisfied with your current creation (i.e. your life) this book reveals the keys to change! It is definitely not spelled out in the book, but anyone who has experimented with Tarot magic, decan spirits, or worked with magical Kabbalah will find plenty of clues to follow up on. As above, so below. This is a text that you will re-read many times, and find it a starting of point for much research. If you are serious about your kabbalistic studies and/or work within a Golden Dawn (or one of its derivatives, e.g. BOTA) framework, this book is an essential resource and is a tremendous value when you consider that it presents information not available anywhere else. \$45.00, available from Archive Press, Box 11218, Boulder, CO. 80301; or Editions Le Chaos, 6100 Wilderton #12, Montreal, Quebec H3S 2L1. 

400 Titles

## Rare Book Reprints

Alchemy Ancient Wisdom Astronomy Baconian Eastern Thought Egyptology Esoteric  
Freemasonry Gnosticism Hermetic Kabbalah Metaphysical Mystery Schools Mystical  
Mythology Occult Philosophy Psychology Pyramids Religions Rosicrucian  
Science Spiritual Symbolism Tarot Theosophy and many more!

√ Perfect Bound Paperback Reprints √ Acid-free paper for long life √ Most books with title and author on spines √ New titles published weekly  
Trade discounts √ Visa and Mastercard accepted √ Phone Orders √ Fast Service √ Full Catalog with complete descriptions available

**Kessinger Publishing, P.O. Box 160-LPN, Kila, MT 59920 (406) 756-0167 Fax (406) 257-5051**

All books must be prepaid in US funds. Shipping and Handling Charges: \$4.50 for the first book,  
and .50 for each additional book. Foreign orders multiply total by 15% for surface or 45% for air mail.

- ADIRAMLED, *Art of Alchemy or the Generation of Gold*, 73 pages, ISBN 1-56459-319-3, \$12.95  
ALBERTUS, FRATER, *Golden Manuscripts*, 160 pages, ISBN 1-56459-303-7, \$16.95  
ANONYMOUS, *Compendium of Alchemical Processes*, 173 pages, ISBN 1-56459-344-4, \$16.95  
ANONYMOUS, *Hermetic Triumph and the Ancient War of the Knights (1740)*, 220 pages, 1-56459-280-4, \$24.95  
ANONYMOUS, *Lives of the Alchemystical Philosophers*, 400 pages, ISBN 1-56459-352-5, \$27.00  
ASHMOLE, ELIAS, *Theatrum Chemicum Britannicum*, 633 pages, ISBN 0-922802-890, \$32.50  
BEGLEY, WALTER, *Biblia Anagramatica*, 212 pages, ISBN 1-56459-016-X, \$9.95  
BEGLEY, WALTER, *Biblia Cabalistica*, 158 pages, ISBN 1-56459-017-8, \$9.95  
BOYLE, ROBERT, *Sceptical Chymist*, 452 pages, ISBN 0-922802-90-4, \$36.00  
CHAMBERS, *Alchemy and the Alchemists*, 64 pages, ISBN 1-56459-005-4, \$9.95  
COCKREN, A., *Alchemy Rediscovered and Restored*, 158 pages, ISBN 1-56459-148-4, \$17.95  
ENCYCLOPEDIA BRITANNIA (1771), *Eighteenth Century Chemistry as it Relates to Alchemy*, 173 pages, ISBN 1-56459-304-5, \$17.95  
FERGUSON, JOHN, *Bibliotheca Chemica*, 1085 pages, ISBN 1-56459-001-1, \$75.00  
FIGULUS, BENEDICTUS, *A Golden and Blessed Casket of Nature's Marvels*, 391 pages, ISBN 1-56459-180-8, \$19.95  
GARSTEN, E.J., *Secret Fire*, 120 pages, ISBN 0-922802-20-3, \$17.95  
HAMILTON-JONES, J. W., *Bacstrom's Alchemical Anthology*, 152 pages, ISBN 1-56459-154-9, \$17.95  
MUIR, M.M. PATTISON, *Story of Alchemy*, 208 pages, ISBN 1-56459-019-4, \$18.95  
PARACELSUS, THEOPHRASTUS, *Archidoxes of Magic*, 160 pages, ISBN 1-56459-171-9, \$17.95  
PETRUS OF FERRARA BONUS, *New Pearl of Great Price*, 441 pages, ISBN 1-56459-142-5, \$29.95  
PHILALETHES, EIRENAEUS, *Collectanea Chemica*, 160 pages, ISBN 0-922802-81-5, \$16.95  
RALEIGH, A.S., *Science of Alchemy*, 172 pages, ISBN 1-56459-007-0, \$16.95  
RALEIGH, A.S., *Speculative Art of Alchemy*, 191 pages, ISBN 1-56459-006-2, \$16.95  
RALEIGH, DR. A. S., *Hermetic Fundamentals Revealed*, 127 pages, ISBN 1-56459-370-3, \$14.95  
READ, JOHN, *Alchemist in Life, Literature, and Art*, 120 pages, ISBN 1-56459-210-3, \$17.95  
READ, JOHN, *Prelude to Chemistry*, 328 pages, ISBN 1-56459-015-1, \$24.95  
READ, JOHN, *Through Alchemy to Chemistry*, 206 pages, ISBN 1-56459-013-5, \$19.95  
REDGROVE, H. STANLEY, *Alchemy Ancient and Modern*, 141 pages, ISBN 1-56459-143-3, \$17.95  
REGARDIE, ISRAEL, *Philosopher's Stone*, 204 pages, 1-56459-282-0, \$17.95  
RIPLEY, *Compound of Alchemy*, 90 pages, ISBN 1-56459-077-1, \$12.00  
RULANDUS, MARTINUS, *Lexicon of Alchemy*, 466 pages, ISBN 0-922802-92-3, \$30.00  
STOLTZIUS VON STOLTZENBERT, DANIEL, *Little Mystic-Magic Picture Book*, 231 pages, ISBN 1-56459-027-5, \$15.95  
TAYLOR, F. SHERWOOD, *Alchemists, Founders of Modern Chemistry*, 246 pages, ISBN 1-56459-002-X, \$24.95  
VALENTINUS, BASILUS, *Triumphal Chariot of Antimony*, 205 pages, ISBN 1-56459-021-6, \$17.95  
WAITE, ARTHUR EDWARD, *Alchemical Writings of Edward Kelly*, 220 pages, ISBN 1-56459-166-2, \$19.95  
WAITE, ARTHUR EDWARD, *Hermetic and Alchemical Writings of Paracelsus*, 800 pages, ISBN 0-922802-1-81, \$37.95  
WAITE, ARTHUR EDWARD, *Hermetic Museum Restored*, 700 pages, 1-56459-284-7, \$39.95  
WAITE, ARTHUR EDWARD, *Secret Tradition in Alchemy*, 413 pages, ISBN 0-922802-83-1, \$33.00  
WAITE, ARTHUR EDWARD, *Three Famous Alchemists*, 186 pages, ISBN 0-922820-84-X, \$16.95  
WAITE, ARTHUR EDWARD, *Turba Philosophorum*, 211 pages, ISBN 0-922802-99-8, \$14.50

# The Spagyric Technique

by Robert A Bartlett

(Originally published in Essentia)

If we look the word spagyric up in the dictionary, it will tell us that the word is from the Greek language: spao, to separate, and ageiro, to reassemble: That is to separate and reassemble. It will also relate the word to two others, alchemy and iatrochemistry (medical chemistry attributed to Paracelsus), which we will find are one and the same.

When the word alchemy comes up, people generally get a stereotype picture in their minds of an old man in medieval dress in a dark cellar full of furnaces, bellows, retorts, flasks, and possibly a dried alligator suspended overhead, Attempting to make gold from lead and produce the elixir of life. A number of misconceptions have clouded the science of alchemy for a long time.

Alchemy has been described as an art and a science since very early times. Like all the arts and sciences, progress comes slowly in the course of investigation. So too with alchemy which didn't die out or turn into chemistry in the middle ages. True, alchemy suffered a great blow to its credibility during the Middle Ages when quacks and charlatans took advantage of the people, promising gold and perfect health through alchemy. During this time alchemy as a science sank further into the background and at times underground all together. Presently it is coming out of the closet, and serious investigation into methods and concepts proposed by the alchemists are receiving worldwide and professional attention.<sup>1</sup>

Much of the problem understanding alchemy is the semantics used, that is, the unusual language employed by the alchemists to conceal in a descriptive and symbolic nature their work. Another problem encountered in the investigation is that alchemy, per se, is actually one branch of a three branch science known collectively as the Hermetic philosophy or Hermetic art. The other two branches are astrology or esoteric astronomy and a philosophical system of correspondences and interrelationships which has come to be called Qabala. As the great Swiss alchemist Paracelsus admonishes, one has no right to study and practice alchemy unless he is fully grounded in each of these three branches.<sup>2</sup>

Now this is usually enough to turn most investigators away, especially when they begin to wade through some of the literature. If you have ever read alchemical writings, you will know what is meant here. These writings, to the unprepared student, read like riddles and make no sense at all. With some persistence however, the basic framework of alchemical thought can be constructed not only from the ideas and writings of the Middle Age alchemists but also from the ancient birthplaces of alchemy, such as Egypt, China and India. The fundamentals of alchemy were expressed identically in these ancient centers of civilization, only the words or particular symbols differed. These concepts have to be the same if, as the alchemists profess, this science is based on the operation of nature and the cosmos.

Now there is no possible way to explain the whole alchemical work in the short space of this article or several volumes. An attempt will be made to briefly present the fundamental ideas of the Hermetic art and explain what the alchemists were and are trying to do. Finally, some of the results of the investigation of the methods used for preparing alchemical or spagyric substances will be discussed.

First, the alchemist perceived the universe to be divine in origin, that is, one ultimate, intelligent, and incomprehensible source, from which all things proceed and into which all returns. It is that universal principle which transcends understanding and can only be given a name or a symbol. Whether it is called the universal life force, the One, God, or whatever, it represents the ultimate and absolute reality of the universe. As the alchemist says, from the One came two, the law of polarity. This idea of polarity is present in all things and is a fundamental concept to alchemy. This is one of nature's most basic rules, that everything has its opposite pole: positive - negative, light - dark, hot - cold.

These two, positive and negative, inherent within the one source, combine in a balance to form the law of the triangle, that is positive, neutral and negative. This law of the triangle, referred to as the three essentials, is a cornerstone in the foundation of alchemy. To the alchemists, these three essentials are present in everything and symbolically are called the alchemical salt, sulfur and mercury. The negative, receptive principle was labeled the salt of the body. The positive, driving principle was called the sulfur, character or consciousness. The neutral, all penetrating principle was called mercury or spirit because of its volatility and represented the energy of life force. Thus man and all things were considered to be triune in nature, that is, consisting of a body, soul and spirit. Today we might think of these three essentials as the time - space - energy continuum, if we relate the body or vehicle to space, the soul or consciousness as time, and spirit to energy.



Now the alchemist says that the three essentials manifest through the four elements. The four elements were symbols for fundamental qualities, thus fire, water, air and earth represented the qualities of matter. The fire element is described as being expansive, radiant or electric. The water element as contracting and magnetic. The air element as motion, flow and diffusion. The earth as resistance, or inertia. These four elements, acted upon by the three essentials, were blended in various proportions to create the physical manifestation of a substance. In a sense, the three essentials were thought to become manifest physically by clothing themselves in vehicle formed by the interaction of the four elemental qualities : electric, magnetic, flow and inertia. By analogy, this can be thought of on a more physical level as the solid, liquid, gaseous, and plasma phases of matter or as earth, water, air, and earth respectively, acted upon by the three essentials of pressure, temperature and volume, which determine the state of the material's manifestation.

Continuing the alchemist's riddle, it is said that in the four elements there is a fifth element, the quintessence, which isn't one of the four but one of the three, namely the mercury or spirit. Thus what we call the living state becomes manifest in the four elements. By analogy on yet a different level, we can think of the four elements C, H, O, N, which make up 98% of the earth's biomass, 3 coming together in various proportions to produce again four classes of molecules: amino acids, lipids, carbohydrates, and nucleic acids, which in turn are organized to form the organism manifesting the living state.

Since, to the alchemist, the universe is a cyclic flow into and out of one ultimate source accompanied by a mixing of these basic essentials and qualities, all things are related. A very well known alchemical axiom states "that which is above is like unto that which is below and that which is below is like unto that which is above."<sup>4</sup> The alchemists perceived man as an image or reflection of the macrocosmos and was thus called himself a microcosmos. We enter now into some basics of astrology which are essential to understanding what the alchemical work is all about. Now the object of alchemy was to assist nature in bringing about the perfection of a subject. When something was in perfect harmony with the universal natural flow of energy, it had attained its goal. By study of the macrocosmos, the alchemist hoped to understand the workings of the microcosm and so assist nature by effecting a balance or fine tuning of the subject's energies in accordance of the natural rhythm of the universe. Through prolonged astronomical studies and correlation to terrestrial events, the alchemists perceived a definite relation between motion of the heavens and occurrences on earth.

The band of the ecliptic, in which all the planets and the sun seemed to move, was of primary importance. Each 30 degree section of space delineated between groups of stars, called zodiacal signs, were thought to be sources of energy with very definite physical and mental characteristics. These energies were focused and concentrated in the sun

which in turn acted much like a step down transformer, The sun radiated to the planets in its system which in turn modified the energies in a character \*\*\* manner by absorbing part of the energy and radiating the rest. Thus each planet also had a specific type of influence. This constant flow of energy and shifting patterns of its modulators created extremely diverse interaction and resonance, sometimes referred to as the "music of the spheres".

Further investigation by the alchemists showed nature to work in a cyclic manner that there were cycles within cycles ad infinitum. We cannot enter too deeply into a discussion on this interesting subject, but we should present at least a sketchy outline of how the alchemists applied this theory to their work.

Basically, two methods were employed. First was the astrological horoscope, or hourview, which was a map of the planets and zodiacal signs in relation to the earth. For a particular individual, this was erected by the time of birth or full manifestation as a separate entity in the physical world. This horoscope represented a cross section of the person's world line as it progressed through time and space. From this map the alchemist could determine many things about the individual, his strength and weaknesses, his character, and how he will be effected by various stimuli. These things were determined by a set of correspondences linking the planets and signs with influences and objects. It seems very complex but actually has definite rules and structures in practice. This cross section of the world line was progressed through time and space by a process the alchemists applied. Almost as if the alchemist anticipated some relativistic effect, the horoscope, and thus the map showing the interaction of the individual with the cosmos, was progressed by equating a day's motion of space with a year of effects on earth. That is to say, the blending of energies in the macrocosm in one day, would take a year to enfold its effects on earth.

The whole science of astrology was developed to relate these various interactions of universal energy currents to the energy matrix or condensation which was the individual. At times the individual could be thrown out of balance with the natural progression or flow of energy. Imbalances such as this could be corrected theoretically by the alchemist with his variety of preparations, which we will soon discuss. Actually the picture is not this simple, as other effects had to be tied in to the horoscope interpretation. For example, the planets' day to day motion also played a part in modulating the energy received by the individual. Also the cyclic workings of nature had to be considered. This is another fascinating and essential concept of alchemical thought. Briefly, there was said to be two major cycles at work in the solar system based essentially on the precession of the earth and how we are orientated in space.<sup>5</sup> There was a 12 phase cycle of physical influence related to the zodiacal signs and the regions of space they mark. There was also a 7 phase cycle of mental influence on consciousness which was related to the planets. These cycles could be broken down to cycles within cycles until spans of time convenient to deal with and study were arrived at.



Again the aim of this astrological study was to determine where an individual was deficient or imbalanced and out of tune with the flow of nature and its evolution. Once this was understood, the alchemist could attempt to bring the subject back into balance and thus assist nature in its goal by removing any resistance or destructive interference to its flow. This balancing of the individual was considered to be a union with the "will" of the highest source, that is, a divine union where the individual becomes conscious of the works of nature and his own part of the universal scheme. A variety of methods were used by the alchemist to effect this balancing or tuning of the individual. Of primary interest are the actual physical preparation used medicinally by the alchemists, the so called alchemical elixirs. This multitude of alchemical preparations possible causes us to point out only a few and to illustrate why and how of their preparation according to alchemical principles.

There is actually only one method involved but many ways of accomplishing the same end. This one method is the spagyric technique. As mentioned earlier, spagyric means to separate and reassemble. To the alchemist this separation step was concerned with separating the three essentials from a substance of mineral, vegetable or animal origin.

The three essential themselves were, as mentioned before, transcendental qualities which operated through different vehicles in the physical world. The alchemical salt or body appeared as a fixed white mineral salt. The alchemical sulfur or soul appeared in an oily, combustible vehicle, and the mercury appeared in the form of a volatile, clear fluid. Alchemically, a separation of these three distinct substances could be effected on vegetable, animal, or mineral materials.

After the separation of the three essentials came the next step of spagyric separation, that of purification. The alchemist says, that which is essential is not destroyed by the fire: it is only purified thereby. Control of the heat and its proper regulation through out the preparation of the substance was stressed most emphatically by the alchemists. Through careful regulation of the heat, each of the three essentials was brought into a purified state by distillations and calcinations. Finally when all three were pure, the final step in the process was to reassemble them in a balanced manner. Usually the alchemical salt or body was saturated with the sulfur and mercury, then allowed to digest as nature more easily sought her own balance in the purified materials. The substance ultimately arrived at was considered to be not only a concentrated extract of the original substance but a living medicine in a perfect state.

As an illustration of this technique, the spagyric preparation of a medicinal herb will be described briefly. The time of gathering the plant and the times for carrying out various operations upon it were important considerations of the alchemist. To simplify matters, these considerations will not be included here.

First there is a separation of the three essentials. The gathered plant could be chopped up or finely ground and its essential oils gently distilled out and collected. This distilled substance represents the alchemical sulfur and was regarded as containing the character or soul of the plant. The oily distillate could contain a variety of volatile plant components, such as terpenes, ketones, aldehydes, and esters. This would depend on the particular plant used.

The next separation was effected through a fermentation process. After distilling the essential oil off, the residue is closed in a vessel with an air lock and allowed to naturally ferment in water. Nothing foreign to the plant was added such as yeast cultures and sugars. Alchemically speaking, the soul or consciousness of the plant was extracted in the oily distillate and the plant now dies during the fermentation and putrefaction process, giving up its spirit to the watery medium around it while the dead body, called the caput mortem, sinks to the bottom. From this fermentation liquid was distilled the alchemical mercury, which was the vehicle of the plant's spirit. The volatile and clear distillate could contain various substances such as primary and secondary alcohols, usually up to around C4 in length which could be free or esterified. Ketones, particularly methyl ketones, and aldehydes, as well as some residual terpenes, could also be present, not to mention some water that would inevitably come over.

Again, the actual composition would depend on the original plant used.

The alchemical sulfur and mercury has been separated, and now the dead body or alchemical salt remains. The first step of the spagyric method, that of separation, is thus accomplished.

The next step is to purify each fraction separately. The plant residue would be dried and calcined over a low flame into a white ash. This was now the purified body or alchemical salt. The oily fraction was usually distilled very gently and was called the alchemical sulfur. Finally the volatile alcohol portion was rectified many times to remove any water and increase the liquid's volatility and penetration. This was the alchemical mercury or spirit. The three essentials were now in their purified states and the second step of the spagyric method was complete.

The final step was the recombining of the three essentials carefully and in a balanced manner. Usually the salts were placed into a vessel and just saturated with equal amounts of the alchemical sulfur and mercury. The vessel was sealed and allowed to digest, reimbining with fresh sulfur and mercury solutions when the salts appear dry. Occasionally the residue produced was removed from the process of digestion and imbibing repeated. This last step of the process could be carried out for months or even years. In time the substance becomes a powerful medicinal, according to the properties of the original plant used. If this process was carried out further, it could result in the production of a hard stone called by the alchemists the herbal stone or opus minor, the "little work". The properties of such a stone were said to far excel those

of the plant alone. At this stage, the plant was thought of as regenerated and elevated in the prepared stone, an actual living medicine. Unusual properties were ascribed to the herbal stone, as the following excerpts from a German alchemical manuscript, first published in 1690, illustrate:

*Our circulatum minus is only a specificated elixir, belonging to the vegetable kingdom, by which without any fire or further preparation of the vegetables, we can in a moment extract their true essence, containing their virtue, quality and property: which is a great chymical curiosity, performing wonders in the practice physick, and in demonstrating some works of nature.*

*We call it circulatum, because, tho never so often used in any extraction, or chymical experiment whatever, it loses nothing of its quality or property.*<sup>7</sup>

Again in another volume, entitled *Collectanea Chemica*, the herbal work is mentioned thus in reference to its properties.

*There being in your tinctures a real permanent power to extract the essential virtues of any herb you may require by immersion only, where the essential salt and volatile spirit, together with the sulfureous oil, are all conjoined, floating on the top of the tincture and the terrestrial feces precipitated to the bottom. Such is the virtue of our vegetable tincture: and if the operation be never so often repeated with different herbs, it loses nothing of its virtue, or of quantity or quality*<sup>8</sup>

Similar descriptions can be found in alchemical literature, and we point out again that these medicines produced were used according to the hermetic philosophy to establish a balance within the individual and bring him closer to a state of perfection.

The work on plants was used to illustrate the primary methods of spagyric preparation. The same principles were applied to animal and mineral substances. Minerals, spagyricly prepared, were said to be extremely dynamic medicines with abilities to cure such diseases (imbalances) as cancer and leprosy.

Oils from minerals? A stone from a plant that extracts from other plants? It all sounds like a tall story. Why would alchemists from different parts of the world at different times all write about similar experiences with these substances? These are some of the questions which prompted the actual laboratory work of this investigation. Was it possible to work along alchemical lines and produce some of these unusual substances and, if so, what are they and how do they work?

The work on plant materials seemed to be clearest and most straightforward experiment to begin with. What seems simple in speech or writing is sometimes more difficult in real life and numerous initial attempts to produce an herbal stone ended in failure or at best a partial success. Fortunately, from one's mistakes a little more light may be shed on the subject and the experience grows. Initial failures can not be blamed on some assumed inadequacy of the method, especially when further research shows many places where error in interpretation could arise. For example, when the alchemist spoke of the oily sulfur

fraction of the plant, did they mean the essential oils as terpenes or could this sulfur also be the various resins, waxes and fats present in the plant? The present state of this research has been concerned with preparative work and only now are definite results beginning to show.

We briefly enter now into a description of several of the variations of the spagyric technique that are presently still under investigation. The first phenomenon of primary interest in this study was to attempt to prepare an actual herbal stone, that is, the herbal substance described by the alchemist both physically and property wise. The first material chosen to work with was the common sagebrush of Idaho's mountain areas, *artemesia tridentata*. This plant was chosen because of the inexpensiveness of obtaining several pounds of the fresh leaves and because of the relative abundance of essential oils which could be collected easily.

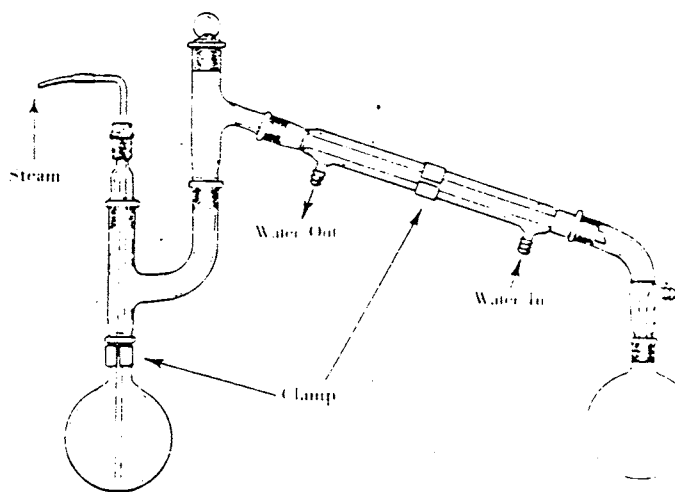

Steam Distillation

Five pounds of the fresh herb was collected and mashed in a grinder, then placed in a large steam distillation apparatus. After 12 hours of gentle steaming, about 15ml of clear golden oil was separated. The strong scent of this oil showed it to consist of the essential oil of sage. The Handbook of

Chemical Taxonomy of Plants describes this oil as containing camphor, pinene and artemisol.<sup>9</sup> However, since it is unclear at present just what the alchemists meant by the term oil, other than its ability to float on water and dissolve in alcohol, the collected oil fraction was labeled as the purified alchemical sulfur and a separated sample set aside in case later analysis was desirable.

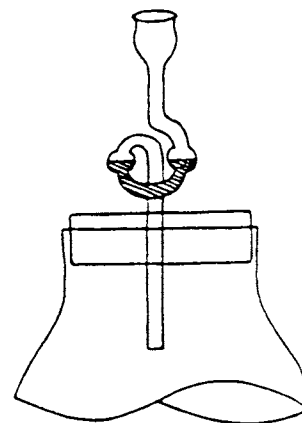

Fermentation Lock

The plant residue remaining, the steam distillation apparatus was then closed to the air with a fermentation lock and allowed to ferment naturally at room temperature. When fermentation had ceased, the substance was distilled slowly until only water began to come over. Assuming that the ethanol, the desired fraction, to have been separated, the distillate was rectified several times under vacuum, dried with potassium carbonate and redistilled. This was labeled as the purified alchemical mercury and essentially consisted of ethanol with traces of volatile oils and water.

Finally, the residue remaining in the distillation flask was dried and calcined over a low gas flame to a light grey ash. The ash was leached with distilled water and the soluble salts collected after allowing them to crystallize by evaporation. Some difficulty arose here as to how the salts should be obtained. In the work on sage, the water soluble salts described above were collected and labeled as the purified alchemical salt, while the small amount of fixed salts remaining after the leaching process was discarded.

At this point the alchemical salt, sulfur and mercury were assumed to be separated and purified according to the precepts of alchemists, and the final stage of the spagyric process was now begun. This consisted of reuniting the separated three essentials by saturating the salts with equal portions of the oil and alcohol fractions or alchemical sulfur and mercury. After saturation the substance was sealed tightly and allowed to digest at 100F. After a month of digestion, the substance was transferred to a retort and resaturated with oil and alcohol. After applying a vacuum, the retort was slowly heated and the substance distilled gently to dryness. The residue was removed from the retort and calcined in a clay dish to

a grey white ash. This process of saturation, distillation and calcination was repeated three times, each cycle requiring about a month. The substance at this point was dark with a reddish hue, and when placed over a Bunsen burner in a porcelain crucible, fused to a clear liquid which became a hard white solid on cooling. The white solid was collected and ground, (about 2g.solid), then placed into a small reflux apparatus where it was again saturated with oil and alcohol. The reflux continued for several weeks at a low temperature, then slowly the heat was raised to the limit of the heating mantle and just as slowly lowered. The substance was removed and had a light tan color. This was again fused over a Bunsen burner and became a white hard solid on cooling. The fusion proceeded much quicker than previously. The solid was ground and returned to the reflux apparatus and the cycle was repeated. This process called cohabitation must be continued until

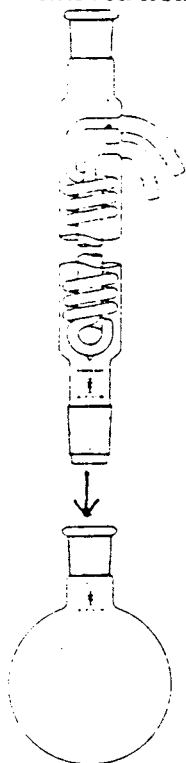

Reflux Apparatus

the substance does not absorb any more liquid fractions but remains as a hard white solid, which should easily fuse over a low flame.

The method just described for preparing the herbal stone seems to be the most successful so far. A good deal more remains to be done on this preparation as far as bringing it to completion, testing it to see if it possesses the properties claimed by the alchemists, and analyzing the end product in order to understand how it might work. Since there were long spans of time where no work could be done, several methods of preparing the herbal stone were attempted simultaneously.

Another method investigated was tried on black pepper. In this method several ounces of ground black pepper corns were extracted with rectified ethanol in a soxhlet apparatus. According to the alchemist, the alchemical mercury, that is ethanol, is the same throughout the vegetable kingdom so the concentrated extract of pepper was labeled as the alchemical sulfur and mercury conjoined. This extract contains chaucine, piperine, piperdine, volatile oil (mainly the terpene L-phellandrene) and resin.<sup>10</sup> But again at present this is not of primary importance in the production of the herbal stone. If we work along alchemical lines, it is sufficient to label the this extract as the sulfur and mercury. As in the previous method with sage, the water soluble salts of the pepper residue were collected and ground fine. The salts were placed into a container and saturated with the extract then placed into an incubator at 100F after sealing. Because of the concentrated nature of the extract, much of the piperline crystallized out of solution. These crystals were collected and ground together with the water soluble salts which had previously been saturated with the extract. The substance was resaturated several times as it became dry. At this point the substance was very readily fusible and gentle distillation in a retort is at present under way. The distillate will be added again to the residue and replenished with more extract if necessary, then the cycle of cohabitations repeated until no more extract is absorbed and the substance remains as a hard white solid, the herbal stone.

A final method which required a more complex type of separation was also attempted using wheat germ. In this method, about 2 pounds of wheat germ were allowed to ferment in distilled water for 6 months until well decayed into a mush. The fermented substance was placed into a large distillation flask and the first half by volume was distilled over. This represents the fire and air elements of the wheat germ, and the residue remaining represents the water and earth elements. The fire and earth fraction was then distilled in half to separate the fire, which were in turn distilled into three fractions each giving a total of six fractions of equal volume and labeled as: #1-mercury of fire, #2-sulfur of fire, #3-salt of fire, from the fire element: then, #4-mercury of air #5-sulfur of air, and #6-salt of air from the air elements. In a similar fashion the water and earth elements were first concentrated to a honey like liquid and then distilled until just dry. This honey like liquid was separated by distillation in to thirds labeled #7-mercury of water, #8-sulfur of water, and #9-salt of

water. The dried residue was now distilled over a higher flame until no more moisture or thick resins would come over. This distillate was distilled to remove the liquid fraction from the thick oily resins. Three fractions were thus also obtained from the earth element labeled #10-mercury of earth, #11-sulfur of earth, and the fixed residue remaining as #12-salt of the earth.

In continuing this method, equal portions of fractions #1 through #6 are combined and poured on

to the calcined fraction #12. After about six weeks of digestion a green tint should become apparent in the liquid. The liquid fractions 1 through 6 are said to represent the positive active principle of the plant, and the portions 7 through 12 to represent the negative passive principle.

The cohabitations to be performed consist of incubating the purified salts. #12, with a balance of these active and passive principles. When no more will be absorbed, the solid residue remaining is fused and saturated with the essential oils of wheat germ as it cools. Theoretically the result will also be an herbal stone with the same properties mentioned previously.

A great deal more work remains to be done in this study as all three "stones" are brought to maturity. Results so far favor the first two methods but it remains to be seen if any of these three methods will produce the desired end product, the herbal stone, which actually works according to the descriptions by alchemists.

One method postulated as to how the herbal stone might work from the descriptions we have involves some type of enzymatic activity either from the plant itself, that is natural enzymes from the plant which were unharmed in the separation and cohabitation procedures, or enzymes from bacterial contamination during the later stages of the work. These enzymes would have to be able to break down the plant being extracted by the stone and free its essential oils to the surrounding water. At present it remains as our anonymous author quoted earlier has stated, "a great chymical curiosity."<sup>7</sup>

The second half of this study deals with spagyric preparations of mineral substances. The two minerals chosen to work with were stibnite ( $Sb_2S_3$ ) and magnetite ( $Fe_3O_4$ ). The main objective was to separate out of these minerals the alchemical sulfur which the alchemist assures us is present. The alchemical sulfurs of these minerals were known as the oil of antimony and the oil of iron respectively. Both oils were said to be extremely effective medicines for blood disorders. However, antimony was particularly unusual to the alchemist in that several variations of its oil could be prepared and each was a powerful remedy for certain diseases. The alchemist

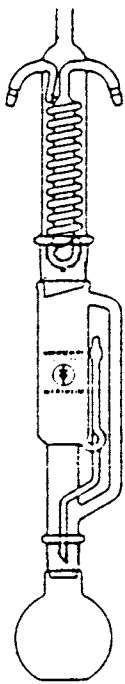

Soxhlet Apparatus

Basil Valentine wrote high praises for the effectiveness of antimonial oils for the cure of cancer, leprosy, lung diseases, ulcers, venereal diseases and external wounds.<sup>11</sup> Paracelsus gave similar credits to these oils in his writings.<sup>12</sup>

The stibnite we used was shown spectrographically to contain no mercury, lead or arsenic ( $Sb_2O_3$ ), which are common impurities. This antimony ore was ground and slowly calcined to a light colored oxide ( $Sb_2O_3$ ) which was then extracted with acetone. A golden tincture resulted and the acetone was removed by distillation. The residue remaining was extracted with diethyl ether and the ether removed again by evaporation. The result was a deep red clear liquid which was oily to the touch and floated in water.

Using a similar process the magnetite was ground and extracted with glacial acetic acid. The acid was removed by distillation, and the residue extracted with ether leaving a red viscous oil which also floated on water. Theoretically and according to descriptions, these are the oils of antimony and iron respectively, at least one form of them.

At present, identification of these oils has just begun. Trace impurities of antimony and iron have been identified in the respective oils as was anticipated. Chromatographic separation on thin layer plates of silica gel has shown antimony oil to contain at least 16 components, two of which are fluorescent under long wave ultraviolet light. The iron was seen to consist of at least three components, one which also fluoresces. More experimentation with chromatographic solvent systems is under way. Once a good system has been developed, a separation of the components by column chromatography will be used and then infra-red spectra obtained for each fraction. Gas chromatography with mass spectrometry will also be used.

As for any type of medical testing of the oil's properties, this will have to wait until a further study is conducted. The main intention at present is to prepare the oils and attempt to identify them.

As a closing note, perhaps we should at least mention the Philosopher's Stone, a substance which stands out in alchemical writings as the goal to which all alchemist aspires. Following along the same lines as previously discussed throughout this article, that is, spagyric method, the alchemists professed the possibility of preparing a substance extremely powerful in its ability to correct any imbalance in vegetable, mineral or animal. This substance was known as the Philosopher's Stone, the Opus Magnus or the Great Work. This substance was considered to be the most perfect spiritualized medicine that could be produced in the physical world. Its power in correcting all imbalances to their natural rhythm was unexcelled, and its final test to prove that it was indeed the Philosopher's Stone was in the transmutation of metals.

Gold was considered to be the most perfect of metals as evidenced by its incorruptibility. The other

so-called base metals were not as balanced as gold. Instead, each metal was thought to have its own characteristic imbalance or disease. And hence was corruptible in nature. Addition of a small portion of the Philosopher's Stone was said to purge off all the impurities from the molten base metal and bring it to the perfect balance of gold. The Philosopher's Stone was thus also called the "medicine of metals" because of this correction of imbalance it could effect.

The Philosopher's Stone could also be taken internally by man with similar balancing effects produced. This substance was said to bring the person into harmony with the universal flow of life and consciousness and to regenerate the body to a purified and perfected state. Thus we see the seeds of the myth-like tales that have surrounded alchemy even to the present day, such as transmutation and the elixir of life: but I hope now we can begin to perceive the alchemical work in a new light. A great deal more work is required in a study such as this, especially when updated literature on the subject is limited mainly to historical data. Research data from various countries is only now slowly finding its way into print, and I'm certain that research will reveal some interesting results as to what many of these alchemical preparations are chemically and more about their medical use.

Who can say at this point? Perhaps cures for cancer, leprosy or heart disease are just waiting to be discovered in alchemy. The only way to find out is to follow the alchemists' road and see if their reported experiments into nature are valid.

## REFERENCES

1. Paracelsus Research Society. Parachemy, Vol. III, No. 2. p.210; 1975
2. Paracelsus Research Society, Alchemical Laboratory Bulletins, No. 4, p.47; 1960.
3. A.L. Lehinger, Biochemistry, 2nd edition, Worth Publishers, Inc. New York. 1970, p. 17.
4. R.M. Lewis, Secret Symbols of the Rosicrucians of the 16th and 17th Centuries, Queen Beach, CA. 1967, p. 15.
5. F. Albertus, Men and the Cycles of the Universe, Paracelsus Research Society, Salt Lake City, Utah, 1970, p. 11.
6. T. Robinson, The Organic Constituents of Higher Plants, Burgess Publishing Co., New York, 1963, p. 112.
7. B. Urbigerus, Circulatum Urbigerus, 1960, Para-Publishing Co., Salt Lake City, Utah, 1970, p. 35.
8. A.E. Waite, Editor, Collectanea Chemica, Vincent Stuart Publishers Ltd., London, 1963, p. 35.
9. P. Tetenyi, Infa Specific Chemical Taxa of Medical Plants, Chemical Publishing Co., New York, 1970, p. 124.
10. A. Osol, G. Farrar, The Dispensary of the United States of America, J.B. Lippincott Co., Pennsylvania, 1950, p. 1546.
11. B. Valentine, A.E. Waite editor, The Triumphal Chariot of Antimony, Vincent Stuart Pub. Ltd., London, 1962, p. 102.
12. A.E. Waite, The Hermetic and Alchemical Writings of Paracelsus, University Books, New York, 1967, pp. 141-142.

Attention Students of Qabala and the Western Mysteries...

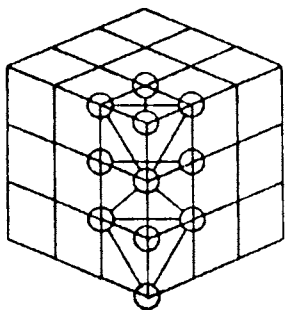

*"In the study of Qabalah there is no more important glyph than the Cube of Space..."*

Paul Foster Case

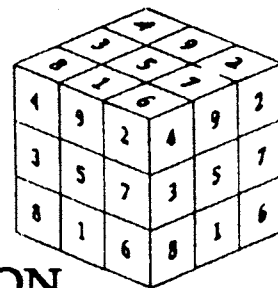

## THE CUBE OF SPACE: THE CONTAINER OF CREATION

a book by Kevin Townley

Topics include:

- \* Generation of the Cube of Space through geometry.
- \* The Magic Square of Saturn.
- \* Relationship of the Cube to the Tree of Life.

- \* Placement of the Tarot (Minor Arcana) on the points of the Cube.
- \* The Cube's relationship to the Macro and Microcosm.
- \* The Cube of Space in the Four Worlds.

To order send \$45.00 plus \$3.00 for postage to  
Archive Press, Box 11218, Boulder, Colorado 80301.

**"As Above, So Below"**

**When you understand the process of Divine Creation on the macrocosmic level, you can apply those same principles on a personal (microcosmic) level!**

# The Alchemy of Politics

by P.R. Churcher

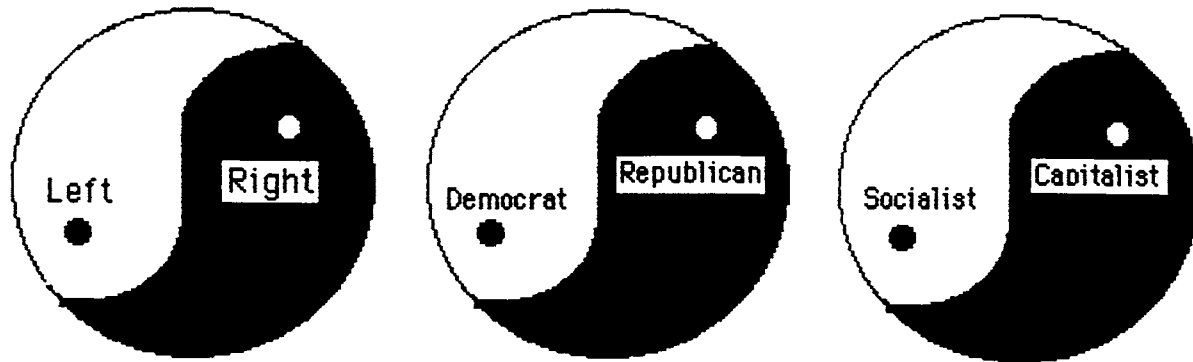

Alchemists are traditionally concerned with working with spiritual energies in plants and minerals, however the same active principles are at work in more worldly human affairs.

Sulphur and Mercury also operate in human society and the fields of sociology, economics and politics reflect the interplay of these two great forces. This is the wholistic view of science, distinct from its analytical academic counterpart. "The wise leader knows about pairs of opposites and their interactions. The leader knows how to be creative." (1)

In terms of these energies all left wing, liberal, Democratic and socialist policies and views reflect a preponderance of Sulphur. Whilst right wing, conservative, Republican and "Free market Capitalist" policies and views reflect a preponderance of Mercury.

This political Sulphur, like all Sulphurs represents a plan, structural and organizational features. It specifically reveals itself (wether as drive, need, belief) as state intervention, organization, social structure and control.

By contrast the political Mercury, in common with all Mercuries, represents function and driving force. It specifically reveals itself (wether as drive, need, belief) as market trading, individual behaviour and absence of constraints.

Like the archetypal two dragons of alchemy political Sulphur and Mercury are engaged in an eternal conflict, in the alchemists world view "Natural events are cyclical, always changing from one extreme toward an opposite." (1). In politics that is what we find, national governments typically alter between left and right wing governments, for example France, USA and GB. So every four or five years one dragon or the other will temporarily gain the upper hand. Therefore Sulphur and Mercury without the guiding hand of the alchemists will render a form of balance through a periodic alteration of political supremacy.

A more sinister side to the unregulated conflict between political Sulphur and Mercury is the sheer human misery which such imbalanced conflicts can produce. This can reveal itself as human wars, national divisions and poverty, for example Cambosia, Vietnam, Germany and Korea.

However a failure to allow Sulphue and Mercury to interplay and conflict can equally lead to catastrophe. Where Sulphur is allowed unrivalled supremacy as in the former USSR and Romania, a sterile society emerges in complete stasis. Where Mercury is allowed unrivalled supremacy as in Gutamala and Brazil massive imbalances of Mercury result with tragic human consequences of death squads, greed and need. The correct balance of Political Sulphur and Mercury is the alchemists art. The political alchemists should follow in the footsteps of our bronze age ancestors who changed the landscape in an effort to reunite earth current (Mercury) and solar forces (Sulphur). The solution to the imbalanced conflict between political Sulphur and Mercury is the Alchemical process.

1-Political Sulphur and Mercury have to be extracted from the matter to be worked on. This is relatively easy as they exist in ideas, distinct from the physical stage on which politicians act.

2-Once extracted political Sulphur and Mercury have to be purified. This requires the elimination of all impurities, the lassitude of the individual in Sulphur, the greed of the individual in Mercury, the bureaucracy of the stse in Sulphur, the tyranny of the free market in Mercury. In other words the politics of the left and right are theoretical abstractions which cannot exist in isolation and therefore as intellectual artifacts they are impure.

3-Once cleanded political Sulphur and Mercury have to be united in the body, this will require many reiterations. This can be achieved through education, discussion, communication and information of all sorts. The body is the political stage and the mind of man.

4-Perhaps finally political Sulphur and Mercury will be reunited in the body and a new exalted political system will emerge containing the best features of both forces ("One Sulphur and One Mercury together make the Tao" to paraphrase (2). This will be a faully functioning system that operates to maximize the benefits of its members and society as a whole. Neither left nor right, but transcendent. Greed and poverty will be seen as imbalance and por health of the political system. The alchemist works on the political system to correct

imbalance with "acupuncture" of the refined intellect.

The alchemist must intervene to achieve this end because the rest of mankind is lost in "the ten thousand things" as the Taoist referred to the world of forms "People who see the world in terms of theories often have a very intricate view of what is happening. Clarity is difficult for them."(1). In the ten thousand things, ideas such as communism and capitalism appear real, they become the intellectual property of people to be defended and used. This unsophisticated thinking results, for example, in the divorce from left to right, which can be seen from the diagrams above to be in dynamic interplay in the complex of materia prima (or the Tao). The results are the social disasters that half of mankind has inflicted on the other half.

"when a person forgets that all creation is unity, allegiance goes to lesser wholes such as the family, the home team, or the company. Nationalism, racism, classism, sexism; all arise as consciousness of unity is lost. People take sides and favor this versus that."(1).

To use the analogy of Ripley's "Twelve Gates" the following are the kind of processes that an alchemist needs to apply in the political sphere.

**PUTREFACTION**- Ideas of the distinctiveness of left and right must be broken down. Each be necessity contains its opposite.

**CALCINATION**-The matter must be purged of its impurities, these are the extreme views developed when left and right wing views are developed in isolation.

**CIBATION**-This body of new ideas is taken as the vehicle for further intellectual development.

**SEPERATION**-The new body of ideas will always appear to seperate into left and right. This natural tendency must be expected and nurtured, however as ideas emerge their natural antithesis must be acknowledged.

**SUBLIMATION**-Gradually a core of fertile political solutions emerge which adopt new higher principles and offer a new direction forward.

**CONJUNCTION**-In these new ideas will be seen a referent to a possibility of complete transcendence of left and right, a middle way that embraces the best of both and at the same time is neither.

**MULTIPLICATION**-These ideas may be explored by individuals and communities.

**PROJECTION**-Finally these ideas can be tried out in practical situations as social policy.

### References:

(1) Heider: "The Tao of Leadership" & (2) Needham: "Physiological Alchemy"



## "More than meets the eye..." at TRIAD.



### \* HERBS \*

Over 500 bulk herbs, including the hard-to-find, as well as Ayurvedic and Chinese. Many tinctures and herbal blends available. Request free lists.

#### SUNDEW (Drosera)

Cut & Sifted,  
1 - 9 lbs \$19.95/lb  
10 - 20 lbs \$17.95/lb  
Over 20 lbs \$16.95/lb

#### CARAWAY SEED

whole, from Holland  
1 - 5 lbs \$4.50/lb  
6 - 10 lbs \$3.75/lb  
Over 10 Lbs \$2.50/lb

#### HORSETAIL

Cut & Sifted  
1 - 5 lbs \$7.00/lb  
6 - 10 lbs \$5.75/lb  
Over 10 lbs \$4.25/lb

### \* ESSENTIAL OILS \*

From rosemary to rose, from the common to the exotic, from commercial grades to the finest aromatherapy grades, we can

meet your specific needs. Oil diffusers and blends available. Custom blending service. List available.

### \* SUPPLIES AND ORES \*

Antimony ore, native sulphur and other materials available upon request. Let us quote on your specific needs. Triple-distilled mercury as low as \$7.99/lb.

### \* ALCHEMICAL T-SHIRTS \*

One of our most popular items is this line of fine shirts with designs from the ancient texts of the alchemists and mystics. Catalog sent upon request.

### \* BOOKS and TAPES \*

Over 10,000 books and tapes available. Topics include alchemy, qabala, astrology, healing, Western and Eastern spiritual paths. Rare reprints available, too. ALL TITLES AT 10% DISCOUNT. We also supply 'New Age,' classical and instructional music tapes, and many instructional videos.

### \* AND MORE..... \*

We carry homeopathic remedies, Bach flower remedies, incenses, Tarot decks, jewelry items, and more. There is so much more than meets the eye at TRIAD.

Send inquiries to:

**TRIAD**  
125 West Front Street,  
Suite 275  
Wheaton, IL 60187  
USA

*Sue and Russ House, proprietors.*

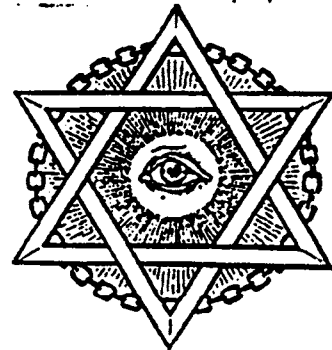



# Path of Flamel: French Research Update

On June 5 and 6, 1993 a Level Four workshop was held at Clervans Castle in Chambley, France. The subjects covered were the Laboratory procedures and techniques used by Nicholas Flamel to prepare the animated mercury and then to seed the mercury in order to attain: a. The Philosophical Tree, b. The Black Stage of the work, and c. The White Sulfur of Nature. Yves Arbez also gave an evening lecture in which the symbolism of The Book of Abraham the Jew was discussed. The particular Manuscript referenced is the one originally owned by Knight Denis Molinier. This manuscript is 396 pages and comes in two volumes. The first volume contains: The Book of Abraham the Jew and The Book of Numbers and Prayers which provide a link to the Alchemical Plane. The second volume contains: Flamel's Alchemy, better known as the Breviary and a number of other texts such as Merois' Labyrinth, the Relationship Between Fables and the work of the Philosophers and the Catechism of the elects in the form of a poem,

"The seed is no other than the salt of metals"  
"Which must be reduced into calx according to the art..."

"The nine must precede the three which will follow it."  
"Put down two than seven, seek and you will find..."

"But you do not join Mars to his dear Mistress"  
"You won't obtain the fruit resulting from their tenderness"  
"That is to say the son made in such a way"  
"That no one plainly knows whether it is a boy or girl"

The Manuscript is lavishly illustrated and contains Flamel's Alchemy with commentary by Denis Molinier and a number of color plates. It should be noted that we have had the Breviary portion of the manuscript translated into English and made it, along with the color plates from "The Book of Abraham the Jew" available in a velox bound edition, for those who would like to study the Way of Flamel. The Manuscript as a whole is a true encyclopedia on the Alchemical Path of mercury amalgams and as one studies it and finds a resonance with it there is to varying degrees an enlightenment on the work that occurs. Evidently the texts copied were written in different time periods and furthermore several individuals shared in the work of copying it. There is a coherence and unity to the collection in which Qabala, Alchemy and Mythology come together to form a unified overview. Additionally the document was quite evidently used by an Alchemist as the texts are covered with annotations and work notes making it also a "Laboratory Diary". There are presently a number of LPN France members transcribing the manuscript along with all its annotations which has been a long and painstaking undertaking. It will be many months before we see a completed product (in French).

LPN France also recommends a number of Supplemental texts which can be studied in order to clarify this Path of Alchemy.

1. Greek - Egyptian Fables by Pernety.
2. Hermetic Dictionary of Myths by Pernety
3. Flamel's works: The Book of Hieroglyphic Figures published by Couvier du Livre.
4. Breviary published by Edition d'Art Savary.

The manuscript also contains references to the work of Philalethes whose thoughts are very close to Flamel's. Thus, the book by Philalethes "The Open Door to the Closed Palace of the King" is recommended as well. Additional works of interest are Coelum Philosophorum, and the alchemical writings of Newton and Robert Boyle.

The contents of the workshop and lecture on the symbolism will be presented at the September 20-24 workshops (See following article by Russ House).

It is possible that some of the products of the Flamel research project will also be brought over from France for the workshops. Jean Dubuis said at the April seminar that a Mercury tree would probably be ready in time for the September workshops as well as other items of interest. Whatever is brought in September it is clear that LPN France in honoring its stated purpose of making available through lessons, newsletters and seminars the fruits of their research to all who are interested in such matters. The Philosophers of Nature is in turn doing its part in seeing that the works in French are translated into English and to host periodic workshops in order that this material can be made available to English speakers worldwide.



# T.P.O.N. To Host Five Day Workshop at St. Charles, IL. September 20-24, 1993

*by Russ House*

We are excited to invite readers of *The Stone* to take part in the most extensive seminar of its kind on the continent! Twelve officers and members of LPN-France are travelling to the Chicago area to conduct a seminar on the three primary paths of LPN: Esotericism, Practical Alchemy and Qabala

On Monday, Jean Dubuis will speak of the initiatic path - a path free from guru, master or priest. It is necessary to become free in order to accede to true initiation, to a genuine realization of the nature of Self. Jean, a scientist who has worked in nuclear physics, has devoted nearly four decades to the study of esoterics. He will share valuable insights which may provide keys for your progress along the Path of Initiation. During the evening, Jean-Claude Pajot, will reveal/discuss his research on the text of The Book Of Abraham the Jew, the primary text for LPN research on the Path of Nicholas Flamel. Jean-Claude, a highly respected mathematician and a leader in high esoteric circles of Europe, will talk of the qabalistic and alchemical keys in this rare text. On Friday, Jean Dubuis will lecture in additional aspects of theory and practice, with a question and answer period.

On Tuesday, Wednesday and Thursday, it is time to get your hands into the act along with the head and the heart. On Tuesday, you will join one of three groups and study one section of the curriculum on practical alchemy. On the following days, your group will study different topics in alchemy. By Thursday afternoon, each group will have had all three practical classes. (See schedule following this article-ed.)

"The Foundation of Spagyrics" will be taught by LPN President Marc-Gerald Cibard, and Etienne Cornaille. In this class you will learn the steps necessary to complete a plant stone, a powerful tool for self-initiation. The rectification of alcohol from red wine, extraction of plant tinctures using a soxhlet, purification of plant salts by calcination and solve-coagula, steam distillation of essential oils and methods of imbibation and incubation to prepare a stone, and related topics are covered in this one day course.

Michel Auger and Jean Francois Gadblet, members of the research staff will conduct a seminar in "Advanced Spagyrics and Topics in Metallic Alchemy". Michel, a pharmacist and Jean Francois, a computer engineer, will show advanced methods to produce very important stones from plants having no essential oils. These stones can assist in contact with the Inner Master. They will also demonstrate improved methods of extracting the alchemical sulphurs from metals. Bring your questions on other metallic paths, such as acetate work.

"The Path of Flamel" has been the focus of immense attention in France. Nicholas and Pernelle Flamel are generally accepted as adepts who attained the Red Stone of the Philosophers in 1382. A rare manuscript copy of The Book of Abraham the Jew, with later commentary and addition by Denis Mollinier, has been the primary model for this research.

Yves Arbez, Vice-President of LPN France, and Patrice Maleze, research staff member, will lead the practical workshop on the "path of Flamel". The theory of the work will be explained and the beginning steps demonstrated: purification of antimony from its ore, preparation of martial lunar regulus, preparation of the amalgam, and distillation (the first eagle). Other topics, including the process of seeding, incubation, and the regulation of the fire will be discussed.

For three evenings, psychotherapist Serge Villaverde will present exciting information regarding dreams. Learn practical techniques to assist you in understanding your dreams, so that they become a personal tool for transformation and growth within the framework of the initiatic path.

The seminar will be held on an 80 acre site with abundant wildlife, where you can walk through forests of arrow straight trees and along winding paths lined with berries and wild flowers. The site is near St. Charles, Illinois, west of Chicago, and is only a few miles from the Winfield location for the previous seminars. There are facilities to house up to 80 people on the grounds, in lodging ranging from modern lodge facilities with fully equipped kitchens to platform tents. The "Wild Rose Program Center" is ideally suited to our needs, and will offer us an opportunity to work together in harmonious surroundings. We are making the final selection of caterers and will offer an optional meal package at nominal cost. Details on this, and the area hotels will be given in the registration package.

Please register at once to assure your place in this historical event! We are broadly advertising this seminar and expect an overwhelming response. As has been our practice, the seminar is open to members of LPN as well as to non-members.

For the workshop information package please write Karen High, P.O. Box 11218, Boulder, CO 80301. Tuition is \$375.00 for members; \$425.00 for non-members. Daily rates & couples discount available.

# SCHEDULE OF EVENTS:

## SEPTEMBER 20 - 24 1993 WORKSHOP SCHEDULE

	MONDAY	TUESDAY	WEDNESDAY	THURSDAY	FRIDAY
9 AM TO NOON	JEAN DUBUIS Blueberry Lodge Hall ALL ATTEND	MARC AND ETIENNE TRACK 1 YVES AND PATRICE TRACK 2 MICHEL AND JEAN - FRANCOIS TRACK 3	MARC AND ETIENNE TRACK 2 YVES AND PATRICE TRACK 3 MICHEL AND JEAN - FRANCOIS TRACK 1	MARC AND ETIENNE TRACK 3 YVES AND PATRICE TRACK 1 MICHEL AND JEAN - FRANCOIS TRACK 2	JEAN DUBUIS Blueberry Lodge Hall ALL ATTEND
1:30 PM TO 5 PM	JEAN DUBUIS Blueberry Lodge Hall ALL ATTEND	MARC AND ETIENNE TRACK 1 YVES AND PATRICE TRACK 2 MICHEL AND JEAN - FRANCOIS TRACK 3	MARC AND ETIENNE TRACK 2 YVES AND PATRICE TRACK 3 MICHEL AND JEAN - FRANCOIS TRACK 1	MARC AND ETIENNE TRACK 3 YVES AND PATRICE TRACK 1 MICHEL AND JEAN - FRANCOIS TRACK 2	JEAN DUBUIS Blueberry Lodge Hall ALL ATTEND
7 PM TO 9:30 PM	JEAN PAJOT Blueberry Lodge Hall ALL ATTEND	SERGE VILLAVERDE Blueberry Lodge Hall ALL ATTEND	SERGE VILLAVERDE Blueberry Lodge Hall ALL ATTEND	SERGE VILLAVERDE Blueberry Lodge Hall ALL ATTEND	
10 PM TO ?	SPECIAL EVENT AT FIRE RING IN MEADOW		SPECIAL EVENT AT FIRE RING IN MEADOW		

**NOTE: Attendance will be limited to 80 in order to insure that the attendees will have a reasonable opportunity for personal interaction with the presenters and the experiments in the Tuesday, Wednesday, and Thursday Laboratory Workshops.**

The specific track each attendee is assigned to in the Laboratory Workshops will be determined by their level of experience in Laboratory Alchemy.

TRACK 1 workshops will offer material appropriate for those with less than 1 years experience.  
 TRACK 2 workshops will offer material appropriate for those with 1-4 years experience.  
 TRACK 3 workshops will offer material appropriate for core group members and those with more than 4 years experience.

The Monday, Friday and all evening programs will be for all to attend. If there is sufficient interest, following the evening presentations on Monday & Wednesday, Kevin Townley will host a special event featuring a potpourri of music, folk dance, and a variety of oratory practices.

# The Philosophers of Nature Spearhead New Research Projects

*by Russ House*

## NOTICE OF ORGANIZATIONAL MEETING FOR RESEARCH PROJECTS

**The organizational meeting for the Philosophers of Nature research projects program will be held September 25, 1993 at 0 So. 651 Jefferson St. in Winfield, IL from 9:00AM - 3:00PM.**

Just prior to the beginning of the LPN Seminar in Illinois this past April, Jean Dubuis, the founder and past president of LPN France met with officers of LPN USA. At that time he asked if I would be willing to assume primary responsibility for seminars and research projects in the U.S., and to act as liaison to LPN France for those activities. I agreed to take on these tasks.

At the present time, our efforts are necessarily concentrated on making final arrangements for the seminar in September. For this reason I have decided to wait until after the the close of the seminar before beginning the Research Program.

I am confident that there are a number of Philosophers of Nature members that are capable of conducting research at the level of competence required, and thereby expand the Light of LPN both here and abroad. In order to determine the specific programs which can be supported, we need to identify, rather quickly, the resources that we can apply to the various projects.

If you are willing to take a part in such research projects, I ask that you write me a letter which is to include the following:

- \* Name, address, phone number, best time to receive calls;
- \* Most recent LPN lessons received: Alchemy, Qabala, Fundamentals of Esoterics;
- \* Number of months/years in experimental or laboratory work;
- \* Description of the focus of your experimentation to date;
- \* Estimated hours per month/year that you could devote to research;
- \* Any relevant training, previous classes, self-study;
- \* Whether you are planning to attend the September 20-24 seminar and will be able to attend the organizational meeting on September 25th.
- \* Other topics which you think are relevant.

For a number of reasons, it would be very helpful if you will respond by mail as soon as possible.

Those who do not feel that they can take on a research project at present, due to perceived shortages of time, experience, facilities, or training, but who would be willing to support the effort would write and let me know how you would like to help. Skills in translation, word processing, desk-top publishing, library arts, access to hard-to-find manuscripts, and an abundance of pure enthusiasm would all be of value to the overall project. Others may wish to donate funds, services, raw materials, or equipment to support these projects. Donations should be made to "The Philosophers of Nature" and specified for use in research projects.

Please send responses to: **Russ House, 0 South 651 Jefferson St., Winfield, IL 60190 U.S.A.**

# New Courses Under Development for Philosopher of Nature Members

by *Bill Van Doren*

Alchemy, Qabala, and Fundamentals of Esoterics form the core course materials offered by the Philosophers of Nature. However, there are numerous additional subject areas which would clarify and otherwise add to our understanding of the core area of studies. At present there are 3 such courses being considered.

## 1. DREAMWORK COURSE

LPN France has begun development of a dreamwork course. An overview of this material will be given by Serge Villaverde, the developer of the course, at the September workshops. Jean Dubuis has found that working with dreams can be of real assistance in accessing and exploring various Sephirotic levels. Such experiences can significantly accelerate one's rate of Initiatic Development. Additional details can be found in the September workshop's literature packet.

## 2. CUBE OF SPACE COURSE

Kevin Townley recently published his book entitled "The Cube of Space: Container of Creation" which is the first detailed account on the subject. The earliest written statement on the Cube of Space was found in the Sepher Yetzirah (Book of Creation) which dates to about 50 CE. It has been said that there is no more important glyph in Qabala that the

Cube - with the possible exception of the Tree of Life. Kevin's book explains why this is so, and goes on to show how the Cube of Space relates to the Tree of Life, the Microcosm and Macrocosm, the Four Worlds, the Major and Minor Arcana, and much more. The book also demonstrates how one can generate the Cube through the use of geometry. In the past two months Kevin has given five seminars; and we will be monitoring the response of those attending the seminars over the next ten months. If sufficient interest is indicated then a one or two year course on the Cube of Space will be developed and made available.

## 3. ASTROLOGY

It is clear that a real need exists for a course in Astrology, designed with the needs of the Alchemist/Qabalist in mind. We have found two astrologers with the background necessary to produce such a course but will await receipt of sample lessons before making any specific announcements.

It may be that in a few years The Philosophers of Nature will offer a wide range of courses and seminars on subjects on the Western Inner Traditions. Such courses will be designed to clarify what is implied by the Path of Return and what one can do to maximize one's growth on the path. I am hopeful that comments and suggestions will be forthcoming from members on course selection and design.



## SEMINAR VIDEOTAPES AVAILABLE

*The first and second Philosophers of Nature Seminars were video recorded  
and the videotapes are now available.*

### A. Video recording of 1st Philosophers of Nature Seminar - 2, 3, & 4th October 1992.

Contents of package:

1. Three video cassettes (Over 15 hours of material).
2. Table of contents of the videotapes,  
keyed to time for quick searches (if your VCR tracks time).
3. Complete graphs and written material provided by LPN France  
on subjects covered in the seminar.  
Price = \$69.95, post paid.

### B. Video recording of 2nd Philosophers of Nature Seminar - 23 & 24 of April 1993.

Contents of package:

1. Two video cassettes (9 1/2 hours)
2. Table of contents of videotapes.
3. Complete graphs and written material provided by LPN France  
on subjects covered in the seminar.  
Price = \$49.95 post paid.

advertisement

Alchemy Academy Australia Presents

## Prima Seminars

### in Hermetic Philosophy & Laboratory Alchemy

by Arthur George Fehres

(partly from information brochure by Don Foster)

Shortly after the death of Frater Albertus in 1984 P.R.S. (Australia) was disbanded, leaving many of his students in limbo. It was then that **Arthur Fehres** began to devote himself to teaching alchemy and closely related subjects. He has laboured, studied and taught practical alchemy continually to the point where his deep insight can now be illuminating to the seeker of Hermetic knowledge.

Since 1981, yearly seminars have been held 'by invitation only'. These seminars were not for novices, but for people with years of study and experience.

Only now, commencing October this year, are six Prima Seminars being offered (in Emerald, near Melbourne) on the foundations of Hermetic Philosophy and practical Truth.

All seminars are non-structured. This allows Arthur to speak freely from the heart. Yet, each contains a predetermined basic content, corresponding broadly to 5 levels of understanding (of alchemical principles) and mastership, hence a total of 5 different seminars, i.e. Prima, Secunda, Tertia, Quarta, and Quinta.

**Prima Seminars include:** the 3 kingdoms of Nature; man as a species and as an individual; who and what we are, and why; the **alchemical** preparation of a potent herbal medicine in the lab by all participants; vital keys to understand alchemical jargon; the gist of the Philosophers' Stone.

**Seminars** are residential, run for 6 full days, and cost only AUST \$675 **including accommodation**.

Treat yourself to this unique inward journey within matter, as well as within yourself. These 6 HOLY-days will reveal the 'one way' double-laned FREEWAY of unified Science and Religion, i.e. **The Royal Road**, the strait to The One. You could be a successful alchemist in a few short years, **this lifetime**. Then you may agree with what is written in 1 Cor. 15:19 *If for this life only we have hoped in Christ, we are of all men most to be pitied.*

For our information brochure write to **Alchemy Academy Australia, P.O. Box 595, Emerald, Vic. 3782, Australia**, or Hans W. Nintzel, 733 Melrose Drive, Richardson, TX 75080

advertisement

## About The Stone



The Stone is published three times a year, in the Spring, Summer, and Fall, primarily for the benefit of the membership of LPN-USA. We hope to get member's feedback regarding what they would like to see in it. Articles, photographs, drawings, letters, and comments from members or others are solicited for submission to the Editor for evaluation. Submissions and advertising should be sent to The Stone c/o Ken Miller, 405 West Washington Street, Suite 314, San Diego, CA. 92103-1996.

## Advertising



The Stone is now accepting advertising, both display and classified ads. Rates are as follows: Full page: \$100; Half page: \$55; Quarter page: \$30; Classified ads are \$0.05 per word. For more information call or write the Editor, Ken Miller, at 405 West Washington Street, Suite 314, San Diego, CA. 92103-1996. 24 hour message line: (619) 491-4500. Calls will be returned collect.

## Subscription to The Stone

The Stone is included in the cost of the lessons. Non-members may subscribe at the rate of \$20 per year. Subscription requests should be sent to the administrative headquarters: LPN-USA, P.O. Box 11218, Boulder, CO. 80301.



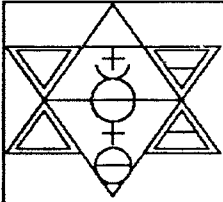

# The Stone

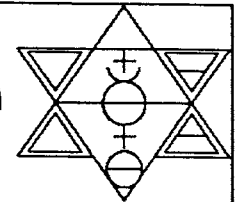

*Journal of The Philosophers of Nature*

Special Collector's Double Issue, Number 9/10

March/July 1994

## Message from the President

*by Bill Van Doren*

This issue of The Stone newsletter features a series of articles which discuss the chain of events which are transforming the Philosophers of Nature from a translation and subscription service to a multi program membership organization

The history of the Philosophers of Nature is well known to regular readers of the Stone. However, over the past 18 months a number of new influences and events have occurred which are altering the nature and objectives of the Association. This issue of The Stone will be primarily devoted to articles reviewing what has transpired. Based on these reports it should be possible get some idea of where the Association is headed in the years to come. The changes are those common to a maturing organization. However, change always causes uncertainty and raises questions. The articles are intended to clarify what is occurring and to provide the needed overview.

The bottom line is that the organization is evolving beyond its original program of translating the lessons and newsletters of Les Philosophes de la Nature in France and then making these lessons available to subscribing English speakers around the world. Today, we are on our way to becoming a multi service organization (offering seminars, conducting research, and eventually expanding the curriculum). These changes are the signs of an organization transitioning from the role of passive recipient of an already formulated body of knowledge to that of a more self directed association which will soon be making its own original contributions in Alchemy, Qabala, etc..

It is important to recognize that these changes were not initiated by myself or Kevin Townley. We have managed the Association in its translation service stage for several years and have felt that getting the lessons translated and

### *In This issue...*

Message From The President; by Bill Van Doren.....p. 1

Evolving Relationships: LPN France and Philosophers of Nature; by Bill Van Doren.....p. 3

Organization Charter.....p. 7

Copyright Proposal.....p. 8

September 1993 Video Tapes; by Rick Grimes.....p. 10

An Old Distilling Apparatus; by Anonymous.....p. 11

How to Make the Stone; by a Father.....p. 12

Vinegar of Antimony; by Anonymous.....p. 15

Acetate Paths; by Russ House.....p. 16

Operative Couplings of the Zodiacal Signs; by Wade.....p. 20

Currents of the Cube of Space; by Kevin Townley.....p. 24

Newton and Flamel: Star Regulus of Antimony & Iron; by Anthony House.....p. 26

A Journey to France; by Russ House.....p. 32

The Walk in the Woods; by Jean Dubuis.....p. 33

A Visit to the "Jupiter Oak"; by Russ House.....p. 34

New Membership Policy.....p. 36

Book Review: The Alchemist; by T. P. Scott.....p. 39

Jean Dubuis Lectures in Illinois & California; by Russ House & Art Kompolt.....p. 41

The Research Group: How it Formed; by Russ House.....p. 42

Study Group in Chicago; by Russ House.....p. 43

Research Seminars and Group Activities; by Russ House.....p.43

Pin-up Chart: Boiling Points of Water & Ethanol in a Vacuum.p. 47

Editorial: Rolling The Stone off the Press; by Ken Miller.....p. 48

**The Stone, Double Issue Number Nine/Ten, July 1994.** Published in March, July & Nov.by The Philosophers of Nature. Editor: Ken Miller; Assisted by Jeanette Davis and T. Branden. Executive Director: Bill Van Doren; Copyright 1994.

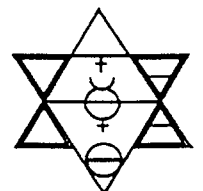
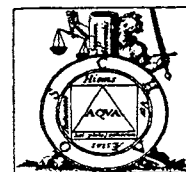



distributed was about all we could do with the resources available to us. The only addition to the original program that we added was the association newsletter. A newsletter had long been desired but didn't come into being until Kevin asked member Ken Miller if he would accept responsibility of publishing of it. Ken graciously accepted and since then as often as sufficient articles are accumulated an issue of The Stone is published.

The initiating impulse to expand the services of the Association actually came from LPN France. In June 1993 Jean Dubuis asked member Russ House if he would be willing to host the 1st LPN France symposium to be held in the U.S. Russ and Sue agreed to take responsibility for the event and in October 1992 hosted the event at their home in Winfield, IL. At the close of the October Seminar it was suggested by Jean that a second seminar be held the following spring. Russ and Sue agreed to this and the Second LPN France Seminar was held at their home in April 1993. After the second Seminar the French asked Russ if he would take on the continuing responsibility as organizer of Seminars. They further asked if he would be responsible for organizing a research group within the Philosophers of Nature, and to become the liaison person between LPN France and the Philosophers of Nature. Russ accepted these responsibilities thus making possible a number of additions to the original program of the Association.

Actually, it had been our desire for a number of years to expand the services and programs of the Association for several years. However, as mentioned above, Kevin and I were never able to develop the monetary support we felt was necessary in order to add additional programs. As a matter of record I had written a series of papers outlining my personal vision of the evolutionary path of the Philosophers of Nature in 1989 and 1990. The purpose of these papers was to project into the future the range of possibilities potentially available to us. The developments outlined in these papers were expected to take 20 years or more to completely unfold and were quite ambitious. However, ideas and papers are one thing to actually manifest such programs on the physical is something else entirely. In any case, it appears that it was necessary that these teachings be made available here in the U.S. and because the Philosophers of Nature as an Association didn't have the resources to initiate these programs the directors of LPN France very generously made the decision to invest their time and the money necessary to bring what they have learned directly to us in America. That decision, and the willingness of Russ and Sue House to accept the ongoing responsibility to organize and direct the events are what brought about the changes we are all witnessing. And of course none of this would have occurred had it not been for the enthusiastic support of all of you, the subscribers/supporters of the Association.

After the April 1993 Symposium we were expecting to relax for a while. However, the French had other ideas and suggested that a major seminar be held in September 1993. Fortunately, Russ and Sue again rose to the occasion, and proceeded to put together a much more complicated and ambitious program at the Wildwood Center in St. Charles, Illinois. By this time, Kevin and I had gotten into the swing of things and did provide some support but in truth 90% of what was accomplished was due to Russ and Sue and their loyal band of helpers.

In comparison to the previous 2 seminars the September 1993 Seminar was about twice as large and many times more complex in terms of the planning and execution. 14 people flew in from France to teach or assist in other capacities. 80 plus attendees came to participate. The scene was additionally complicated when LPN France surprised us with a secondary agenda directed toward reinforcing the relationship between the two Associations. They also suggested that we do what is necessary to make sure that our nonprofit corporation status is in good shape so as to avoid any possible conflict in the future with the laws which define the responsibilities of nonprofit corporations in the U.S. Since the requests made seemed to be in the best interests of all concerned we agreed to work towards achieving what was suggested.

The above briefly outlines the sequence of events leading up to the September 1993 Symposium. One article in this newsletter will review in some detail the events that transpired at the September Seminar which were not a part of the official program and therefore not apparent to the attendees. Other articles will review events and developments that have occurred since last September which have a bearing on how the Philosophers of Nature develops in the future. Many of our readers may wonder if all this detail is really pertinent or think it boring and irrelevant. However, I have requested it be done this way for three reasons:

1. It is not possible for members, who are not involved in the day to day business of the Association, to really understand what lies behind the decisions of the Board of Directors of the Association. This seems to be the rule in business, government and of course esoteric organizations. This may be acceptable most of the time, however, several years down the road when situations change and memories begin to fade much of what has previously transpired in the past tends to begin to resemble a mythology as the actual dynamics of events are lost to view. I personally don't like to have to guess about such things and so have decided that we will bore the membership with details now rather than have members at some future date guessing about how things came about.

2. It is intriguing to note that in reviewing the development of most projects I direct how little control there is over the timing and occurrence of specific events. The process of the creation and evolution of this Association follows this pattern. It has grown and evolved out of a continuum of actions / reactions without any conscious awareness of where it will ultimately lead. From the outset I didn't project a purpose for it beyond a personal desire to see that the lessons be translated into English and then to be made available to subscribers. Actually, looking back even further, the translation project itself was initiated as a conscious attempt to at least partially fill the void left when PRS ceased to function. In any case, I think that it is more interesting if others are aware of this process and, if they wish, to directly participate in it as it unfolds. The true significance of this will only become apparent given the advantages of hindsight

after several years passage of time.

3. In a larger sense I believe that members of the Philosophers of Nature are connected to a long term process which can best be understood and appreciated from a 250 year or so historical perspective. The Philosophers of Nature being a product of this long term evolving process has the opportunity through publications such as The Stone to make available to public view this process as it unfolds. Given this 250 year overview one can get some idea of what is yet to come. From my perspective, the future for those who really involve and devote themselves to this process will be richly rewarding. **The best is definitely yet to come!**



## **THE EVOLVING RELATIONSHIP BETWEEN LPN FRANCE AND PHILOSOPHERS OF NATURE.**

For the first 6 years of the existence of LPN U.S.A. as a translation and subscription service LPN France showed no interest in establishing formal relations between the two organizations. However, beginning in 1992 when Jean Dubuis stated he now was willing and available to teach seminars in North America things began to change a bit, and once Russ House began to host the LPN seminars in the U.S. their interest became evident (although it wasn't at all clear what they had in mind). It was at the 3rd U.S. Symposium in September 1993 that they began to make their desires clear when they suggested that the two organizations establish closer ties.

The suggestion was not a total surprise to us because a few weeks prior to the September symposium at St. Charles they announced that they were bringing their lawyer to discuss business matters. This made me somewhat concerned because I couldn't get them to clarify ahead of time what it was that required the presence of legal counsel. The night before the beginning of the seminar I met Dominique Dubuis, the person that they brought over to conduct business matters for them, and I determined that when they used the term counsellor, which I understood to mean attorney, they meant an adviser. This misunderstanding is indicative of the sort of misunderstanding that run rampant when people of different cultures attempt to do business or understand each other. Another example. During the process of coming to terms with what the French wished to accomplish during the period of the Seminar I became very aware of the significant differences between how the French and how Americans conduct business. Throughout the discussions with the French I would hear a statement and interpret it one way only to later find I was looking at things as an American would and not like the French. I suppose it can be boiled down to a matter of style.. As an American I hear a request or suggestion and I hear a specific statement of intent with some sort of time line connected to it. I consider the time and resources required to accomplish the task and begin to act accordingly. I have repeatedly come up against the fact that time is a culturally relative (variable) factor when dealing with the French. I like to get to the bottom line, get the job done and time is of the essence. With the French what seems to be a higher priority is the development of the relationship. They go into the process of formulating an agreement very slowly and deliberately (according to some sort of culturally determined ceremonial pattern which I have yet to master). I found out that often in a meeting at which I was prepared to conduct business that the business would never even be mentioned unless I brought it up and then there would not be any formal resolution but some general discussion and usually a postponement into an unspecified future date. In short, I apparently missed the some unspoken but very real cultural point and burned up a lot of energy in expectations and then frustration with the rate of progress of the talks. In the end, we did come up with a general letter of intent that was the product of dozens of hours of discussions and meetings (See page seven). This is apparently exactly what the French had in mind to come away with. In my mind this paper functions as a letter of intent and is the basis for future efforts to establish more specific ties. The following is a commentary on a few of the points of the paper (charter).

1. There apparently was a concern that we adopt a legal status appropriate to a nonprofit corporation. This was already addressed because we had incorporated in March 1993 as a nonprofit corporation in the state of Colorado. In addition in June we had filed an application with the IRS for recognition as a tax exempt corporation with a 501 c3 classification (which seems to be the norm for organizations such as ours). The application was sent back to us by the IRS with a list of questions to be answered. Because of all the changes which were then occurring I decided to hold off until spring 1994 to resubmit the application in the hopes we would have a better idea of what direction we are headed in. In any case, most of their concerns regarding our legal status had been addressed earlier in the year. We had also changed our name to Philosophers of Nature which seems more appropriate and meaningful to English speakers than LPN or Les Philosophals de la Nature. Also, prior to the beginning of the Seminar we had conducted a board meeting at which we had added member Russ House as corporation Secretary. Thus, for the most part their concerns about our legal status were mostly already taken care of

.2. Throughout the week of the seminar I worked very closely with Dominique Dubuis (Jean Dubuis' son) who had been appointed as the LPN France person in charge of establishing communications with Philosophers of Nature and representing them in the drawing up of agreements. He was fair and reasonable in his conduct and all in all a pleasure to work with. The language barrier limited spontaneous exchanges of ideas but in general interpersonal relations were pretty smooth. Dominique stated that he would return to the U.S. in the spring of 1994 to continue on with the development of the working relationship between the two organizations. Accordingly, I received a letter in late November stating that Dominique and his translator Jaqueline Renaud would be coming to California in February 1994 and that they wished to meet with me and further discuss the development of a working agreement. After much phone calling and letter writing it was agreed that they would visit my wife Grace and I at our home in Ft. Bragg, CA. for a few days. During their visit the French approach to conducting business matters began to make more sense to me as I now understood that it was more a process of getting to know the person you are dealing with than just the drafting and executing agreements. Really getting to know someone does take time and they seemed quite content to spend the time required to do that. Actually, ( given that it takes more time) it is a much more enjoyable way of doing business. During their four day visit further points were brought out which gave some insight into what the long term objectives and concerns are of LPN France. However, the main focus of this visit was on the Philosophers of Nature copyrighting of LPN France lessons and other intellectual property. At the end of their visit we wrote up and signed a summary of the points discussed which was entitled, "Proposal to Copyright English Translations of LPN France Intellectual Materials"(See page eight ). This paper outlines a plan of action, which if taken, will provide the best legal protection for the translated LPN France intellectual property. t However, the plan requires that the French provide us with certain documentation before we expend the considerable sums of money that are required if one elects to copyright materials in the formal way. Actually, all translated material is copyrighted through our presently adopted method of complying with U.S. copyright law. The paper includes a proposed schedule of joint research fund pledge through which Philosophers of Nature can help fund the ongoing research being undertaken by the two organizations. To date all research costs have been borne by the French. This proposal ties the income obtained from sales of translated material originally created by LPN France to our contributions to the research fund.

To date the two documents outline a potential line of action which can be followed by the two organizations. This program can be carried out within a year provided that the money and the signed agreements are generated in a timely manner. However, there are two time scales in operation here, and so I expect that it will take more like three years to carry this to the point so far defined.

In early March 1994 the French sent over a five person delegation to formally acknowledge the progress being made in the unifying of the programs of the two organizations. This was strictly a ceremonial gesture as no further business was taken up during their stay in the U.S. An account of their visit is covered in other articles in this issue.

What does all this mean to Philosophers of Nature? The following is a list of advantages as I see it of following the lead of LPN France in these matters. To date I see no disadvantages. Advantages:

1. It stimulates us to keep our legal status in line with the standards expected of charitable organizations in the U.S.
2. It will stimulate us to provide the best protection under law of our primary material assets - our intellectual property.
3. The fact of thinking through and then formally acting upon a plan in concert with our Fraternal Brothers and Sisters in France will reinforce and concretize on the material plane whatever it is that we are creating through the fact of our ongoing existence as esoteric organizations.
4. The joint research programs will materially benefit through our financial contributions in addition to whatever we contribute intellectually.
5. Both the French and the Americans will learn to be more patient with and aware of the others cultural ideosyncracies/strengths - which in time will bring about a greater respect and sense of fraternity between the two organizations.

What is the next bigger picture? What is the slightly larger context within which this is being played out?

1. Jean Dubuis takes what he has created seriously and feels that it should be afforded protection accorded by laws of the State.
2. LPN France is expecting that the LPN form will be picked up and adapted by several countries, and perhaps will in time spread worldwide. The U.S. as the tail that could conceivably wag the dog must be properly grounded - spiritually and legally.
3. Jeans time as the de facto head of LPN France can continue only a little longer. The more stable the U.S. form the more support it will provide the French/worldwide form.
4. Political conditions in France/Europe look rather bleak mid term to the French. A strong well grounded organization in the U.S. will provide a stable base should things implode in Europe.
5. Hermeticism in all its forms plays a low profile, yet a significant part, in some larger (invisible) plan involving the evolution of Man. Members of both organizations all are participants/players in this plan (consciously or unconsciously) and what is proposed is done out of respect and concern for this larger Plan.



400 Titles

## Rare Book Reprints

Alchemy Ancient Wisdom Astronomy Baconian Eastern Thought Egyptology Esoteric  
Freemasonry Gnosticism Hermetic Kabbalah Metaphysical Mystery Schools Mystical  
Mythology Occult Philosophy Psychology Pyramids Religions Rosicrucian  
Science Spiritual Symbolism Tarot Theosophy and many more!

✓ Perfect Bound Paperback Reprints ✓ Acid-free paper for long life ✓ Most books with title and author on spines ✓ New titles published weekly  
Trade discounts ✓ Visa and Mastercard accepted ✓ Phone Orders ✓ Fast Service ✓ Full Catalog with complete descriptions available

**Kessinger Publishing, P.O. Box 160-LPN, Kila, MT 59920 (406) 756-0167 Fax (406) 257-5051**

All books must be prepaid in US funds. Shipping and Handling Charges: \$4.50 for the first book,  
and .50 for each additional book. Foreign orders multiply total by 15% for surface or 45% for air mail.

- ADIRAMLED, *Art of Alchemy or the Generation of Gold*, 73 pages, ISBN 1-56459-319-3, \$12.95  
ALBERTUS, FRATER, *Golden Manuscripts*, 160 pages, ISBN 1-56459-303-7, \$16.95  
ANONYMOUS, *Compendium of Alchemical Processes*, 173 pages, ISBN 1-56459-344-4, \$16.95  
ANONYMOUS, *Hermetic Triumph and the Ancient War of the Knights (1740)*, 220 pages, 1-56459-280-4, \$24.95  
ANONYMOUS, *Lives of the Alchemystical Philosophers*, 400 pages, ISBN 1-56459-352-5, \$27.00  
ASHMOLE, ELIAS, *Theatrum Chemicum Britannicum*, 633 pages, ISBN 0-922802-890, \$32.50  
BEGLEY, WALTER, *Biblia Anagramatica*, 212 pages, ISBN 1-56459-016-X, \$9.95  
BEGLEY, WALTER, *Biblia Cabalistica*, 158 pages, ISBN 1-56459-017-8, \$9.95  
BOYLE, ROBERT, *Sceptical Chymist*, 452 pages, ISBN 0-922802-90-4, \$36.00  
CHAMBERS, *Alchemy and the Alchemists*, 64 pages, ISBN 1-56459-005-4, \$9.95  
COCKREN, A., *Alchemy Rediscovered and Restored*, 158 pages, ISBN 1-56459-148-4, \$17.95  
ENCYCLOPEDIA BRITANNIA (1771), *Eighteenth Century Chemistry as it Relates to Alchemy*, 173 pages, ISBN 1-56459-304-5, \$17.95  
FERGUSON, JOHN, *Bibliotheca Chémica*, 1085 pages, ISBN 1-56459-001-1, \$75.00  
FIGULUS, BENEDICTUS, *A Golden and Blessed Casket of Nature's Marvels*, 391 pages, ISBN 1-56459-180-8, \$19.95  
GARSTEN, E.J., *Secret Fire*, 120 pages, ISBN 0-922802-20-3, \$17.95  
HAMILTON-JONES, J. W., *Bacstrom's Alchemical Anthology*, 152 pages, ISBN 1-56459-154-9, \$17.95  
MUIR, M.M. PATTISON, *Story of Alchemy*, 208 pages, ISBN 1-56459-019-4, \$18.95  
PARACELUSUS, THEOPHRASTUS, *Archidoxes of Magic*, 160 pages, ISBN 1-56459-171-9, \$17.95  
PETRUS OF FERRARA BONUS, *New Pearl of Great Price*, 441 pages, ISBN 1-56459-142-5, \$29.95  
PHILALETHES, EIRENAEUS, *Collectanea Chémica*, 160 pages, ISBN 0-922802-81-5, \$16.95  
RALEIGH, A.S., *Science of Alchemy*, 172 pages, ISBN 1-56459-007-0, \$16.95  
RALEIGH, A.S., *Speculative Art of Alchemy*, 191 pages, ISBN 1-56459-006-2, \$16.95  
RALEIGH, DR. A. S., *Hermetic Fundamentals Revealed*, 127 pages, ISBN 1-56459-370-3, \$14.95  
READ, JOHN, *Alchemist in Life, Literature, and Art*, 120 pages, ISBN 1-56459-210-3, \$17.95  
READ, JOHN, *Prelude to Chemistry*, 328 pages, ISBN 1-56459-015-1, \$24.95  
READ, JOHN, *Through Alchemy to Chemistry*, 206 pages, ISBN 1-56459-013-5, \$19.95  
REDGROVE, H. STANLEY, *Alchemy Ancient and Modern*, 141 pages, ISBN 1-56459-143-3, \$17.95  
REGARDIE, ISRAEL, *Philosopher's Stone*, 204 pages, 1-56459-282-0, \$17.95  
RIPLEY, *Compound of Alchemy*, 90 pages, ISBN 1-56459-077-1, \$12.00  
RULANDUS, MARTINUS, *Lexicon of Alchemy*, 466 pages, ISBN 0-922802-92-3, \$30.00  
STOLTZIUS VON STOLTZENBERT, DANIEL, *Little Mystic-Magic Picture Book*, 231 pages, ISBN 1-56459-027-5, \$15.95  
TAYLOR, F. SHERWOOD, *Alchemists, Founders of Modern Chemistry*, 246 pages, ISBN 1-56459-002-X, \$24.95  
VALENTINUS, BASILUS, *Triumphal Chariot of Antimony*, 205 pages, ISBN 1-56459-021-6, \$17.95  
WAITE, ARTHUR EDWARD, *Alchemical Writings of Edward Kelly*, 220 pages, ISBN 1-56459-166-2, \$19.95  
WAITE, ARTHUR EDWARD, *Hermetic and Alchemical Writings of Paracelsus*, 800 pages, ISBN 0-922802-1-81, \$37.95  
WAITE, ARTHUR EDWARD, *Hermetic Museum Restored*, 700 pages, 1-56459-284-7, \$39.95  
WAITE, ARTHUR EDWARD, *Secret Tradition in Alchemy*, 413 pages, ISBN 0-922802-83-1, \$33.00  
WAITE, ARTHUR EDWARD, *Three Famous Alchemists*, 186 pages, ISBN 0-922820-84-X, \$16.95  
WAITE, ARTHUR EDWARD, *Turba Philosophorum*, 211 pages, ISBN 0-922802-99-8, \$14.50

# CHARTER

Chicago, September 24, 1993

Location: Strawberry Lodge, Wild Rose Program Center, Crane Road, St. Charles, Illinois, USA.

Were attending:

Bill Van Doren (LPN-USA) President;  
Kevin Townley (LPN-USA) Vice President, Treasurer;  
Russell House (LPN-USA) Secretary;  
Marc Gerald Cibard (LPN-France) President;  
Yves Arbez (LPN-France) Vice President;  
Dominique Dubuis (LPN-France) Consultant.

During the workshop that occurred September 20-24, 1993, it was jointly decided that a Charter of Friendship and a Working Agreement would be established, in order to guide and direct our future mutual relationships with regard to material issues.

It was agreed upon:

1. That LPN-USA would be reorganized in accordance with the philosophical principles of Les Philosophes de la Nature and the laws of the United States. Bill Van Doren (President) will call and preside over the meetings needed to elect a new board of directors that will be composed of at least a Vice-President/Treasurer, and a Secretary, and the means to appoint project directors for the organization of the various activities as the need arises will also be established. (LPN-USA, as a legally incorporated entity, will be able to operate in all of the United States).
2. Discussions about the necessary procedures and methods, in accordance with the laws of both countries, will be arranged between LPN-USA and LPN-France, in the presence of Dominique Dubuis, who is in charge of establishing an on-going communication, and who is to participate in the drawing-up of the working Agreement (Protocole).
3. LPN-USA and LPN-France shall develop together research projects and projects related to written documents, audio-visual materials, computer programs, and any other intellectual property generated by either organization, and all activities of value to the members, in the name of Service.
4. The respective Presidents and Vice-Presidents, after consulting with each other, will study ways to bring into harmony the material issues between the two Associations. These resolutions will be included in a separate Working Agreement (Protocole), drawn up in accordance with French and American laws, rules and regulations. The Philosophers of Nature (France and USA) will establish, in the name of reciprocal friendship and fraternity, a schedule of communications that will address these issues by March 1994. The board of directors shall inform the members of these developments.

signed on September 24, 1993 by attendees.

# PROPOSAL TO COPYRIGHT ENGLISH TRANSLATIONS OF LPN FRANCE INTELLECTUAL MATERIALS.

## BACKGROUND:

On September 24, 1993 at the week long Seminar held at St. Charles, Illinois a preliminary agreement was drawn up and signed by the Board of Directors of LPN France and the Philosophers of Nature USA. The basic intention of the agreement was to find ways for the two organizations to work together along their common path of providing people around the world with information on Alchemy and QBL, etc. A further intention was to bring the Philosophers of Nature into line with the rules and regulations which govern the activities of non-profit corporations in the USA.

One of the suggestions made by LPN France was that all lessons and other written material translated into English from the lessons and other LPN writings be protected under U.S. copyright through filing by the Philosophers of Nature USA. We agreed to follow up on this and other suggestions and on October 4, 1993 Kevin Townley and Bill Van Doren met with patent/copyright attorney Donald W. Margolis in Boulder Colorado.

In regards to the U.S. copyright of English translations issue attorney Margolis advised the following:

1. Philosophers of Nature can copyright all English translations of the French writings and tapes etc.
2. LPN France must provide Philosophers of Nature with a hold harmless agreement stating that we have permission to translate their lessons, newsletters, audio/visual materials etc.
3. We can file a single copyright application for all lessons comprising a single course such as Fundamentals of Esoteric Knowledge, Spagyrics etc.

Today, 9 Feb. 1994 in a meeting between Dominique Dubuis and Bill Van Doren in Fort Bragg, CA the following issues were brought up as points to be formally acted upon by the two organizations:

A. That the Philosophers of Nature USA will receive the required permission of LPN France to translate into English from the French all lessons, newsletters, audio/visual and other intellectual property of LPN France.

B. That the copyright to all such translations shall reside with the Philosophers of Nature USA.

C. That the English translations of LPN lessons as follows:

1. Fundamentals of Esoteric Knowledge Lessons 1-12
2. Spagyrics Lessons 1-48
3. Minerals Lessons 1-84
4. QBL Lessons 1-72



be copyrighted under 4 separate applications as soon as the final version of each course is completed. The Fundamentals of Esoteric Knowledge course is ready to be copyrighted at this time. A copy of these lessons in final draft form was given to Dominique. After a final copy check is carried out and corrections made this course will be sent to the Library of Congress for copyright.

D. That the right of translation of the intellectual property of LPN France has been given to Philosophers of Nature USA without charge or monetary obligation.

E. However, it is recognized by Philosophers of Nature USA that LPN France is first of all a Research organization and that the lessons, articles, seminars, audio/visual products etc. are all produced from the findings of their on going research projects. Further it is recognized that research of this sort is quite costly in terms of money as well as time. In addition, Philosophers of Nature USA is beginning to make arrangements, under the direction of Russ House, to carry out joint research projects with LPN France. With the above in mind it seems fair and appropriate that the Philosophers of Nature contribute funds to support such joint research projects according to the income schedule below on an annual basis. Income in this case is defined as the gross income before sales taxes on sale of the English translations from the French of all intellectual property of LPN France. The corporate year is from 1 March to the last day of February.

#### PROPOSED SCHEDULE OF JOINT RESEARCH FUND PLEDGE.

(Figures are in U.S. dollars)

0 - 15,000 = 0  
15,001 - 30,000 = 1%  
30,001 - 50,000 = 2%  
50,001 - 100,000 = 3%  
100,001 - 150,000 = 4%  
151,000 - 250,000 = 5%  
over 250,000 = 3%

F. The administration of the disbursement of such funds will be conducted by the boards of directors of the respective organizations or their delegates. The final formula and protocol for such collection and disbursement will be decided after due consideration by both parties.

Note: It is necessary that agreement be finalized on the points described under A D before work can begin on points E & F.

Note: In the event that a member of LPN France or Philosophers of Nature USA produces some written or other intellectual material which is then contributed to their respective organizations for publication and subsequently at a later date copyrights the material and claims it as their personal property, it should be recognized that this is an act of an individual and not the authorized act of either organization.

Signed on this day, 9 Feb. 1994, by BILL VAN DOREN, DONMQUE DUBUIS, and JAQUELINE RENAUD.

# What Happened To The September '93 Video Tapes?

by Rick Grimes

Have you been wondering about the video tapes from the September LPN meeting? I thought so. We videoed everything and have a complete record of the whole seminar. In fact, we even have duplication in several areas. However they are sometimes chaotic, boring especially when the speaker walks out of camera and hard to understand in places. That's why they must be edited carefully so that they contain everything, have an unbroken sound track, and hold your interest.

We finished with over 75 hours of exposed video tape (with three cameras running on some days). This must be reduced to a tight, yet complete, coverage of the seminar.

Current status: the edited masters are not finished at this writing, 3/13/94.

"Why not?", you might ask. Good question. Besides the mental fatigue and saturation I felt at the end of the seminar, as I suspect those of you who also participated did, I had to attend to some editing equipment repairs, move my studio to a new location in October, and solicit and secure a wider client base in my regular job (through November and December). I survived the Christmas holiday in Dayton (a fall on ice resulted in a sprained ankle), and joyfully endured a very busy and lucrative January and February; I need the money.

If I haven't gotten your sympathy with all that, then I'll plead low demand. I have only received two rather feeble inquiries about the videos so far. I think everyone needed a rest. After all, everybody encountered a tremendous inculcation of information in September. Not just a meal, but an ongoing banquet.

As for me, I have to be hungry again to sit through the seminar over and over while editing it into a set of master videos. However, the good news is that the masters will be broadcast quality Super VHS on a two hour basis rather than the lower quality six hour basis as before. This will also facilitate faster production of the copies in Standard VHS (2hr per tape).

You will have your choice to purchase particular seminar talks in individual sets, or all the talks in one complete seminar set. The total number of tapes is unknown at this time, but we are talking to different suppliers who may give us faster duplication service and, hopefully, cheaper prices.

By the time you read this I should already be finished with Serge Villaverde's presentation on dreams. So, with renewed vigor and the prospect of another wonderful gathering in the fall, I am proceeding at full gallop and shall have all the tapes completed in due course. You will be kept informed as to availability and price. Thank you for your patience.



# An old distilling apparatus

By anonymous

While glancing through some alchemical magazines that Father had sent from France I noticed an interesting recreation of ancient 'distilling' equipment done by the french alchemist Solazaref. I have attached a sketch with approximate dimensions.

This apparatus will let you do wonderful work in a waterbath.

Rectified vinegar can be deflegmed and totally distilled over a period of two to three weeks without a vacuum, as can a tincture made with R.V. and antimony glass to obtain the red-gold powder. It may be interesting to try some work i.e. Hollandus with fresh plants or tartar distillate. There are many wonderful works that remain to be done with this apparatus. A pelican may be designed and built using similar principles.

May the light generated by doing the work shine from you and bathe the world as you perceive it.

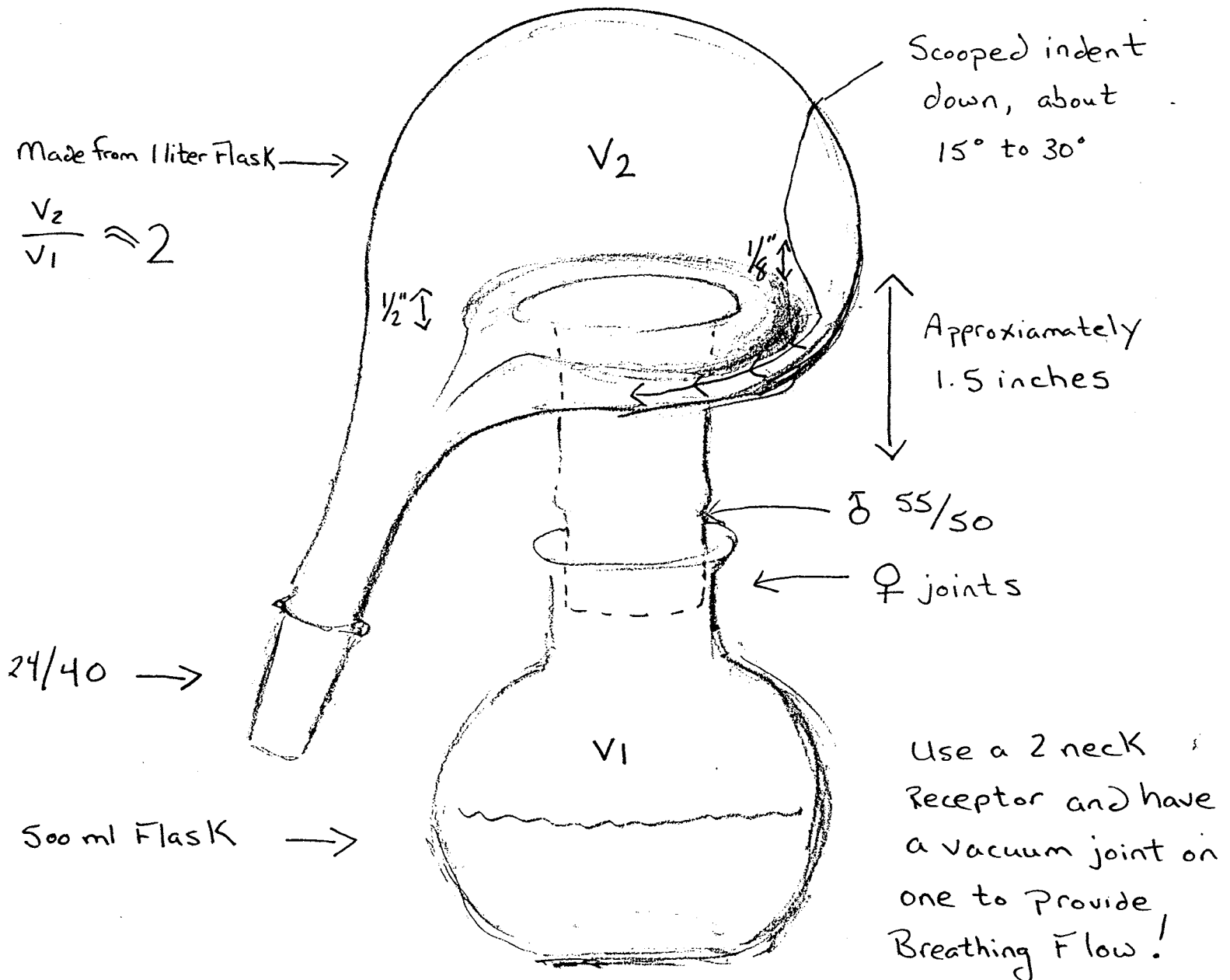

# How to make the said Stone using the wet method: Extraction of salt from the saturn.

*excerpt from a 16th Century manuscript from a Father to his son*

Put ten pounds of minimum in a large pot and pour over it sufficient distilled vinegar to fill the pot almost to the brim, boil slowly, mixing frequently with a wooden spoon; maintain the same heat for three hours. Then pour off the vinegar and filter it; put fresh vinegar in the said pot and boil, as before, for three hours, stirring often, and then decant and filter: and you will repeat this procedure as many times as necessary to dissolve almost all the minimum in the vinegar, leaving a certain blackish residue. In the same pot put another ten pounds of minimum, and continue to dissolve in vinegar as before, until almost all the minimum is dissolved. Then you will put the said filtered vinegar in a partially diluted retort, and distill in an oven without a grate until only one fourth of it remains; this you will put in a glazed white basin covered with a piece of paper to protect it from the dust; allow it to rest in a cold environment, and it will congeal into a salt. Decant the vinegar that has not crystallized, and let half of it evaporate; crystallize once more, and repeat the procedure as many times as necessary to reduce all the vinegar to crystals. You will put said salt in a large pot with a flat bottom, place it in the sun and let it dry thoroughly. Dissolve the said salt of Saturn in common distilled water; after it has dissolved, allow 24 hours for digestion. Then filter, and distill the water until the pellicle forms, and make crystals as above with the vinegar. Dry said crystals thoroughly in the sun until they are reduced to a dry white powder, then once more dissolve them in distilled water, and digest at ash heat for 24 hours; filter, distill and crystallize. And you will repeat this procedure as often as necessary to eliminate all the earthy sediment: then allow the said crystals to dry thoroughly, and store.

Take twelve pounds of the above mentioned purified salt, place in a large retort that will remain two thirds empty, plug the mouth of the retort with a stopper and seal the joints; put the said retort in a steam bath with the neck uppermost, and leave it in the bath for twenty days, at sufficient heat to keep the said salt fused into oil. After 20 days subject the retort to a slow heat equal to the temperature of sand, and allow the white spirits to distill; and when you see a yellowish color near the mouth of the retort, that will be the oil: then immediately remove the retort, wrap it in hot cloth, and when it has cooled somewhat, put the distilled spirits back into it, plug with the same stopper, seal it, and place it in a slow steam bath for seven days. After seven days, distill the spirits only, using the above procedure, and when the distilled spirits begin to take on a citron color remove the retort from the bath, as above, put the distilled spirits back into the retort, seal, allow to putrefy for seven days, and distill at sand heat; and you will do this seven times; the seventh and last time, after having removed all the spirits, change the receiver and increase the heat; the oil will be distilled in the form of a very red butter, which oil you must rectify many times, each time in a new retort, until no residue is left on the bottom. You will do the same with the spirits, rectifying it in a water bath many times, until it leaves no impurity. Store in well-sealed glass containers, separately.

Put the above-mentioned, powdered residue in a pot, cover it, and cook for eight days over average heat that will not cause the powder to become red-hot in any way, as it should not melt. After eight days, increase the heat, but first put the said substance in an uncovered pot, burn in a reverberator furnace for an additional eight days, or ten days, so that it remains darkly red hot. Then, using distilled vinegar, remove the salt, filter, distill, and crystallize; when the said crystals are dry, dissolve in ordinary water that has been distilled three times, filter, distill, and crystallize, and then dry; and again, with the said distilled ordinary water you will dissolve, filter, distill and crystallize, as before, and then after drying continue this procedure until no earthy residue is left in the solution; now dry thoroughly and store in a glass container. In a large flask having a long neck, put one part of the aforesaid salt, add to it nine or ten parts of the above-mentioned spirits of Saturn, stopper with a counter phial, wrap a wet bladder around the joints and place in a water bath or dunghill for 50 days, during which time the substance will putrefy and turn a blackish color: now put it all in a retort, and at moderate heat of sand in a well-sealed receiver, distill until the salt is perfectly dry, and place the distillate back into the same retort, and cohobate many times until the salt is distilled together with the spirit in the form of butter, and rectify three times, each time in a clean little flask; and you will have an incomparable treasure. This butter is called Alkahest, and it radically dissolves all metals, particularly gold and silver (yet keeping them alive), with which you will be able to carry out many special procedures, both with and without colors.

This butter will harden the vulgar Mercury into silver in two hours, perfectly, in this way: Put 50 ounces of Mercury in a retort and cover with the above-mentioned butter so that there is more than a finger of it: stopper, and cook with the neck of the flask uppermost for two hours at ash heat, and the Mercury will be reduced to very white powder: when this is done, distill all the butter into a receptacle, and when the distillation is completed, you will have your butter of the same strength as before, in fact, it will be finer; the powder of Mercury, after being dissolved by means of a bath of luna, will be perfect moon. To make the Stone, you will do the following:

Take equal parts of the said butter and the oil of Saturn, or three parts of butter and one part of oil. Here you have the union of the live sun and the live moon. Put these two substances together in a philosopher's egg, seal hermetically, and decoct at very low heat until they are fixed. Imbibe with an equal amount of oil of Saturn and decoct, and after doing this a third time you will have the stone in fixed oil, which will give a very high projection when treated with very pure gold as described in the other procedure involving the Mercury of Saturn, and after having obtained yields from other imperfect metals, that is, lead, which will be better. You will be able to multiply ad infinitum by imbibing with oil of saturn, and decocting, until it fixes.



---

## REVISED AND DELUXE LESSON PACKAGES NOW AVAILABLE

Philosophers of Nature is in the process of making corrections and newly type setting all the lessons in an improved format. To date, the courses which have been upgraded are:

1. Fundamentals of Esoteric Knowledge. Lessons 1 - 12
2. Qabala. Year one Lessons 1 - 12
3. Qabala. Year two Lessons 13 - 24
4. Spagyrics. Year one Lessons 1 - 24

In addition, we have decided to offer an attractive deluxe binder set which makes it easier to preserve, organize, and to use the lessons. The deluxe package includes the following:

1. One white showcase binder of the appropriate size.
2. One set of multicolor tab dividers numbered from 1 - 12 or 1 - 24 as is required.
3. Table of course contents page
4. Course title page to be used on front of binder.
5. Course title strip to be used on spine of binder

All you have to do is to 3 hole punch the lessons as received and insert into the binder.

All new subscribers will automatically receive the new upgraded lessons of the above listed courses. Subscribers from prior years who would like to receive the revised lessons can purchase them at a cost of 5¢ per page plus postage. Anyone wishing to purchase the deluxe lesson binder package for one or more of these courses may order them from the Boulder office. To order just designate for which course/courses you would like the deluxe binder package and enclose \$12.50 per binder package which covers the cost of materials plus postage and handling. The package/packages will be sent with the next mailing of your lessons.

If you have any ideas on how to further improve the lessons or see corrections that need to be made please let us hear from you.

**ORA ET LABORA**

# TRIAD

125 West Front Street, Suite 275  
Wheaton, Illinois 60187  
Fax/Phone (708) 665-1417

Triad was born more than ten years ago out of our efforts to obtain materials for our personal alchemical research. Since that time, we have helped many people to obtain unusual or hard-to-find materials. We are currently listing some specific products which we have in stock that are of interest to researchers. The materials listed here are (with the exception of antimony ore) in very limited supply, and we are not certain that we will be able to replenish our stocks once these supplies are exhausted.

**All listed materials subject to prior sale, due to demand and limited supply. Refund sent for out-of-stock materials unless you specify alternative choices at time of order.**

**ANTIMONY ORE:** Purest stibnite available. Bolivian, almost pure  $Sb_2S_3$ . Can be used without separating gangue when making regulus. Same as now used by French LPN for research. Prices: 1-5 lbs, \$10/lb; 6-24 lbs, \$9.00/lb; 25-49 lbs, \$8.00/lb; 50+ lbs, \$7.25/lb.

**ANTIMONY TRIOXIDE:** Commercial, technical grade. Price per pound: \$6.00.

**CERUSSITE:** Native lead carbonate ore from Arizona. We bought the entire stock of this material from a minerologist who collected all available cerussite from this site in 1992. Quality is mixed. Small amounts of crystalline material as inclusions. Very limited supply. Price per pound: \$5.00.

**LEAD CARBONATE:** Commercial, technical grade. Price per pound: \$7.50.

**LEAD OXIDE, RED:** (*Minium*) Commercial, technical grade: Price per pound: \$9.00.

**SEA SALT:** From France. Not the 'flower of sea salt' which is now sold out, this is the normal quality of sea salt collected by evaporation in clay beds in northern France. Used as a matrix for synthetic plant stones. Price per pound: \$5.00

**SULPHUR:** Native sulphur from western US. Medium to high quality. No large crystals. \$8.00/lb.

**SULPHUR:** Italian native sulphur. Medium quality, with some large crystalline masses. \$9.00/lb.

**SUNDEW:** (*Drosera rotundifolia*) Imported for us from Europe. Unique, insect eating plant receiving much interest in medicine. Said by LPN to be a 'vegetable antimony' on the level of Malkuth, with interesting experimental possibilities. Price per pound: \$15.00.

**TARTAR:** Red wine tartar from France. We periodically have obtained small quantities through LPN France. Price per pound: \$8.00. Shipped in plastic bag.

**Our inventories include absolutely pure essential oils, herbs, books on alchemy and other esoteric topics, chemicals, mineral ores and laboratory equipment. Please inquire.**

# VINEGAR OF ANTIMONY

by Anonymous

## PROCEDURE:

Take about 500 grams of "Albertus" antimony ore [the author refers to a specific ore of antimony which was available from Paracelsus College years ago], and extract it in a Soxhlet with about 300-400 ml of filtered thunderstorm water. The water may take on a reddish tinge. Prior to incubating, check the pH.

Incubate (or circulate at body temperature) for one to three months. Mild bubbling may be observed if the container is shaken. Decant fluid (check pH), and divide ore into three equal parts. Place first 1/3 of quantity into a flask with fluid. [See drawing of apparatus]. Distill fluid slowly and follow intuition to raise temperature up to 580 degrees C. Leave for three days and nights at this temperature. Dismantle carefully and collect sublimate. Add sublimate and distillate to second 1/3; observe, use good flask, antimony may melt. Things will happen. Be careful, for when you will add distillate to second 1/3/ you will observe increased bulging and/or gaseous pressure. Do not keep distillate or antimony mixtures in closed containers with heat - it will explode.

Get a copy of *Triumphal Chariot*. [The book referred to is a classic text by Basil Valentine - contact Sue House at Triad, 125 West Front Street, Wheaton, IL 60187, \$20.85 includes 2-day postage.] Check pH often. Make sure you understand the apparatus and why it is designed as it is. Internal pressures/vacuum will vary; that is why the expansion bulbs are there. If distillate falls back into hot flask there will be an explosion.

Add distillate and sublimate to third part of ore; re-distill and from here you are on your own!

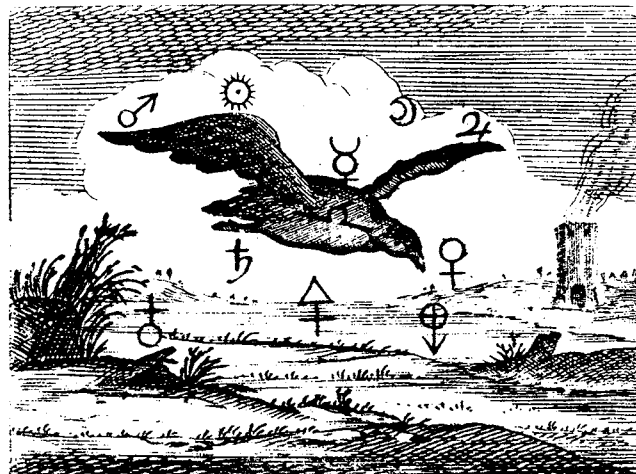

Antimony Vinegar Apparatus

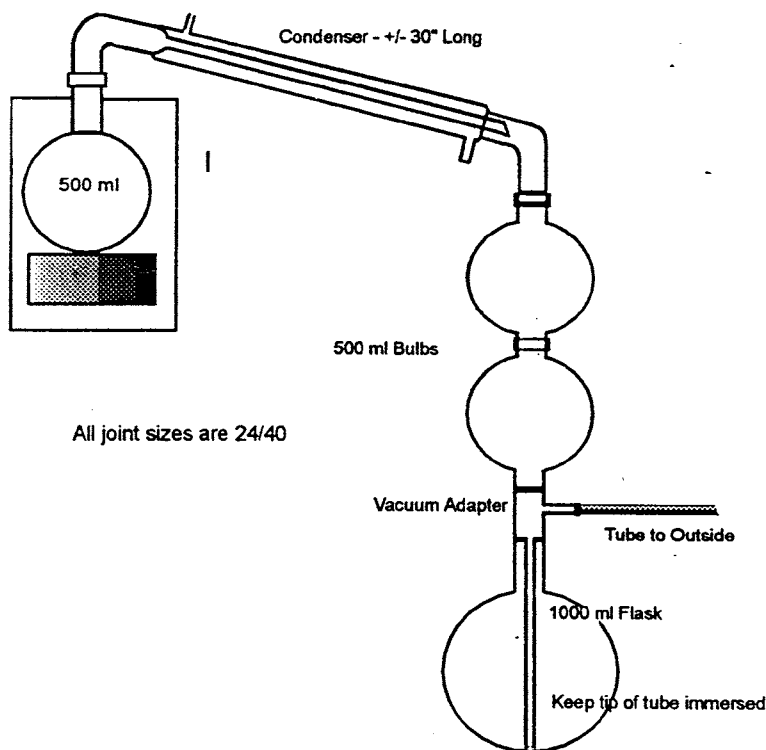

New from Archive Press!

## SPAGYRIC TINCTURES - TRADITION, PREPARATION, AND USAGE

by Beat Krummenacher  
translated from the German by Karin Di Giacomo

This text surveys the Zimpel/Glaber, the Krauss, and the Heinz processes before detailing the author's method.

### LEARN:

The Putrefaction, The Separation, The Purification, and The Cohobation of plant principles!

"The Preparation of Primordial Spagyric Tinctures is rooted in ancient tradition. Even though its procedure is also meaningful from a modern pharmaceutical-chemical viewpoint, a deeper understanding is only possible when we take into account the traditional way of thinking. The following writings therefore have to consider both the basic viewpoints of a chemically oriented science and the traditional world view. If we do not consider both we cannot do justice to the Spagyric process." from the introduction.

Price: \$14.95 + \$2.00 postage

Available now from Archive Press, Box 111218, Boulder, Colorado 80301.



# METALIC ALCHEMY:

## Some Comments on the Acetate Paths

*by Russ House*

Jean Dubuis and the officers of LPN France are aware that there are difficulties related to the Flamel and Urbigerus paths because of the use of metallic mercury. Considering the problems of safety and issues of legality related to mercury work, Jean decided to share his insights on the acetate work. There are still issues of toxicity and other potential problems (corrosive acids, problems of flammability, pressure, cost of equipment, and lengthy processes), the path can lead to results of some value, with less danger.

The following notes are taken from the lecture given by Jean. They are not a complete transcription, nor are they adequate for someone who is just beginning laboratory work to proceed. Jean has prepared some lessons on this topic, which are published in various places in Mineral Lessons numbers 23 through 51, with a more concentrated study given in lessons 31-40. Jean is considering publishing 12 new lessons on the topic, which would incorporate materials given in the lecture. If there is a large interest on the topic, I will arrange for one or more practical seminars on the acetates. Please write to the address on the cover stating your interest. If you are able to arrange for facilities and wish to host for class of 10-12 persons for a weekend class, please indicate that as well.

### Theoretical Aspects

Jean spoke of his researches on the Table of Mendeleev which arranges the chemical elements in columns and rows according to atomic properties. Column 4, wherein we find carbon, silicon, germanium, tin and lead is considered the most important column for the acetate path. Simply stated, the method of this path is to fix vegetable life on a metal so that the metal will evolve like a vegetable. In the column, we will find carbon, the basis of organic chemistry, and lead, the easiest metal to use in the path.

For the acetate work, we will need two alchemical liquids which must carry the secret fire. These are fermented by living things. The secret fire comes into our realm through the media of the air, and descends to the earth through dew and rain. In the earth, it is determined to the vegetable kingdom, generally through potassium salts. The grape is rich in these salts. The vine produces the grape, and from the grape juice, through a fermentation comes wine. A further acetic fermentation produces vinegar. Wine and vinegar are separately distilled.

### A Delicate Matter

Alcohol distilled from wine which is over 70% pure, and concentrated vinegar over 20% acetic acid are delicate matters, and are readily influenced by the psychic energy of the alchemist and others. For this reason, these liquids must be preserved out of the sight and presence of all but the alchemist or their mate, to avoid the contamination. Aluminum is in the column of elements which are toxic to alchemical life. As a result

aluminum and boron compounds are not permitted to contact these, or other living products. Aluminum foil can be used, however, to wrap a bottle and to act as a shield against their interference. These should be stored in the oratory, in the dark.

### Liquid Batteries

These vegetable kingdom mercuries, philosophical alcohol and vinegar, act as storage batteries to retain, and then to give back the alchemical life in the acetate process. These liquids are not in themselves 'mercuries', the mercury being an invisible energy. Rather, these liquids are suitable vehicles for the energy.

Vinegar is more difficult to process by distillation than wine alcohol, requiring 30 or more distillations for purification. An alternative method is to take plastic bottles, and to fill 3/4 full with red wine vinegar of approximately 7% acidity. These are put in the freezer horizontally, and frozen at -30 degrees C.

The portion which does not freeze is decanted into a graduated vessel. 30 to 50 ml per liter will be acid. The portions which are 60 to 80 percent acid are distilled separately from the batches which are 20 to 50% acid.

### Radical Vinegar

A radical vinegar, which is blue in color can be prepared as follows: One needs copper oxide. It is best to prepare it yourself using old copper wires. The purity of copper in electrical wire is often quite high. The wires are put in the furnace and heated until they form a black material. The 20 to 50% acetic acid attained as above is poured over the wires in a flask and allowed to digest at moderate heat for a week. A Soxhlet extractor is not suitable for this step. The resulting blue liquid is quite toxic. It should be

filtered, and then distilled to remove 3/4 of the liquid. The fumes are hazardous and the stink is horrible, so the process should take place outdoors. Distillation must stop before the material is dry! Permit the liquid to crystallize, in a beaker for example. When crystal form, remove them from the container. One should work in this manner to obtain 2 kilograms (about 4.4 pounds) of copper acetate crystals, and dry them at 110 to 120 degrees C.

These crystals are distilled slowly, and an acetic acid of 99% or higher will distill over. This is called 'radical vinegar'. It is blue in color. Jean stated that Paracelsus College taught that the acid thus obtained should be redistilled to remove the blue color, as the copper was a toxic contaminant. It should not be distilled, as it would then lose its philosophical nature, effectively losing its determination on the level of Netzach (the sphere of Venus, which corresponds to copper), and returning to Malkuth on the Qabalistic tree of life. The coloration is due to the acid drawing the alchemical sulfur of the copper.

### On the Other Hand...

The problems of alcohol preparation are better known, in general. A method for distillation was suggested in the previous issue of the newsletter. Alcohol of 95% purity is digested on potassium carbonate for 1 or 2 days. Jean states that the potassium never metalizes the alcohol. One can redistill to get rid of the yellow color if desired. This must be prepared so that it is 100% pure alcohol.

### Acetate Purity Issues

The preferred material to be used to form a lead acetate is galena, a lead sulfide. Previously Jean had used cerussite, a lead carbonate ore. It is

easier to work with, but presents certain drawbacks. The Australian ore was not a crystalline ore, and had many impurities. During extraction in a Soxhlet, the various color changes were one of the indications of the impure material. The resulting product is not lead acetate, but rather a mixture of various acetates.

*h*

### Roasting of Galena

Lead sulfide ore is not easily attacked by acetic acid, so a lengthy roasting process is required in order to create a suitable material. A sketch of the device used to permit a slow, progressive roasting is published in the newsletter. A number of racks made of metal screen are stacked in a closed, vented furnace with an electrical heater producing heat in the range of 150 to 300 degrees C. All trays are loaded. After a month of continual heating, the lower tray is removed, all other trays lowered one level, and a tray of new material placed on top. The diagram indicates a tube leading outside to vent noxious fumes. The 150 degree heat should work in a month, a 300 degree heat in a week. The resulting material is extracted in a Soxhlet with the radical vinegar. The liquid is then filtered and slowly crystallized, yielding philosophical crystals of lead acetate.

### Transfer of Life

The acetic acid content must be removed from the crystals, to permit the transfer of vegetal life. Absolute alcohol, the 100% alcohol previously obtained, is circulated over the crystals. The added alcohol forms an acetic ether, with a distinct

odor. After circulation the material is recrystallized, then circulated again in pure alcohol. The lead dissolves very slowly in the alcohol. An acetic smell at any stage indicates that it is necessary to continue. The cycle of circulation and crystallization continues for 2 to 3 months. The resulting material is placed with philosophical alcohol in the incubator for a month at 40 degrees C during a lunar cycle to facilitate the transfer of the energy in it into the metal.

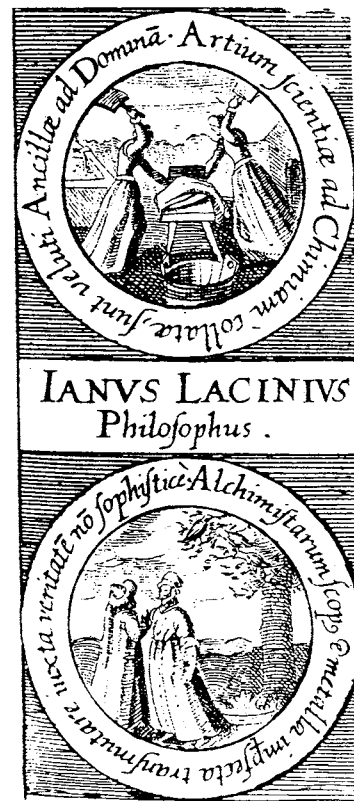
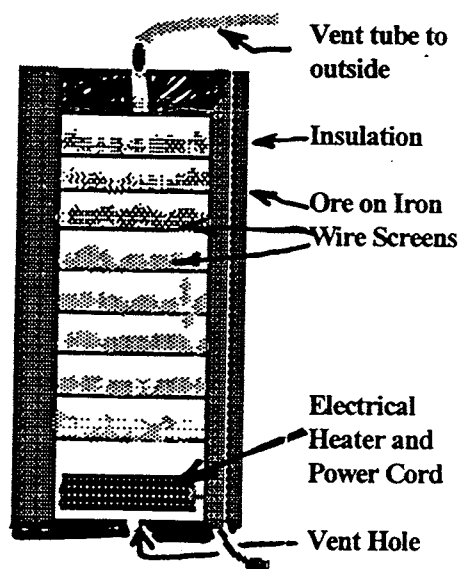

After incubation for a month, the material is ready to be distilled. Please refer to the figure below. [The details of the lower coil condenser are inadequate to construct such a piece of apparatus. Full details will be provided upon request. Please enclose SASE...].

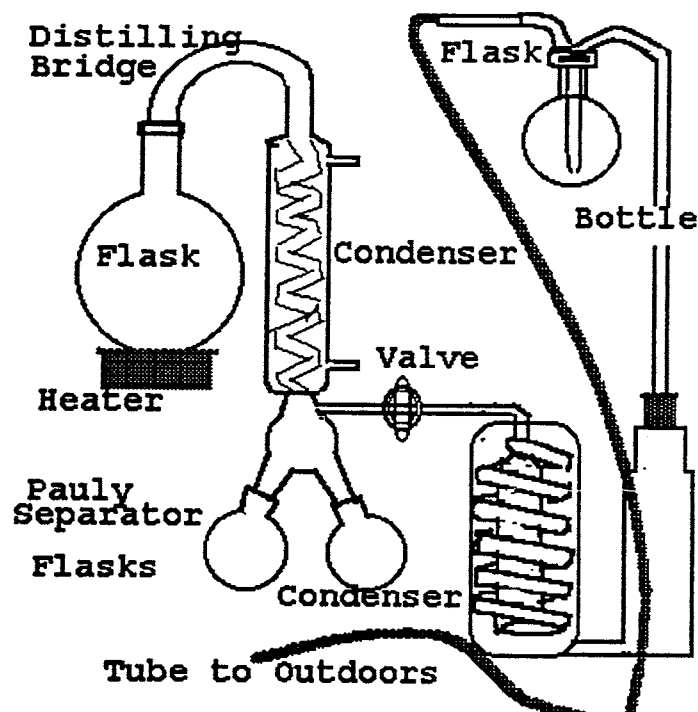

The Pauly Separator is to be considered mandatory. The lower condenser should be well insulated. The outer chamber is filled with cooling liquid. For example, 100 grams of ice with 143 grams of  $\text{CaCl}_2 \cdot 6\text{H}_2\text{O}$  (Calcium chloride), will give a temperature of 55-60 degrees below 0 Celsius. This is easier to use than mixtures like acetone and dry ice.

Distillation causes a variety of liquids to be driven off and condensed, which necessitates the Pauly separator. First will come any residual alcohol, with the 'water of crystallization'. There should be no acetic acid distillate. When red oil begins to appear, there will also be white smoke throughout the system. When the white fumes start, stop the heat.

There should be about 250 ml of volatile distillate in the lower condenser. In the high-placed flask, 5 or 6 ml of distillate will collect. It is to be kept closed for a full day, after which time, some red oil may separate from the mixture.

The volatile distillate should be frozen in a silicone sealed flask until required. This is the so-called Philosophical Mercury according to some.

To test the 'mercury' pure gold should be placed in a well sealed flask or tube with some of the volatile liquid and incubated for one month at 40 degrees C. If the mercury is good, it will take a tincture from the gold.

The black-gray material in the bottom of the distilling flask, the so-called "Black Lion", will self calcine if it comes into contact with the air when it is hot. It will heat to 700-800 degrees C! Therefore, only open it when it is cold. Crush to dust on a ceramic plate, making a layer 1-2 mm thick. Ignite it with a hot poker, and it will rapidly combust. This will yield the *terra foliata*, or foliated earth. This is a metallic earth.

One now has the earth, which is a *salt*, the red oil which is the *sulphur*, and the volatile *mercury*. Don't be greedy, use lots of mercury. In any case, you will make only a small stone. Imbibe the earth with the red oil. Saturate and digest for a week. Repeat 3 or 4 times. The material is then placed in a 'philosophical egg', and the mercury from the freezer is added, to a proportion of 1/3 of the volume of earth. Place in the incubator. It must not see the light at all while in incubation, as we are working to light the 'dark fire'. In 2 to 3 days at the appropriate temperature, the

secret fire is lighted, and after 8 days, the mercury is fixed. Remove the egg from the incubator, and dip the egg into hot water, at the same temperature as the temperature to light the fire. Now one uses dry ice and NaCl (sodium chloride or salt) in the collar around the egg. Additional mercury from the freezer is added slowly, with the egg inclined or banked so that the mercury is not rapidly heated when it contacts the earth. There is a problem of high pressures at this time. This is repeated seven or eight times over a 3 or 4 month period, after which time it is possible to get a stone.

A completed stone appears like a hard, white wax. It is the white stone. Copper, silver or mercury can be transmuted with it. Copper is transmuted at a 1:1 ratio of copper to stone. Jean has not multiplied this white stone. It is thought that it could be multiplied with silver. In trying to take the stone to the red work, Jean thinks that it may be possible to use the mercury to dissolve gold, and then use that mercury in the work.

In another method of making the stone, which method was given to Jean by a good German alchemist, the *terra foliata* is imbibed with the red oil, and placed in a sealed ceramic crucible. The crucible lid was clamped to the crucible with a clamp made of metal plates above and below, with asbestos pads between the ceramic and metal surfaces. Jean used 12 crucibles for the work. In this process, to fix the life or oil is critical. Begin with incubation at 40-50-60 degrees C. At each stage, open one crucible to see if it is yet fixed. Raise the temperature slowly, open another and examine the matter. It is an initiation of the matter, which will follow a specific color sequence: black (Earth), blue (Water), yellow (Air), red (Fire), white again (Quintessence). Raise the heat slowly 50 degrees a month to 300 degrees C. After 150 degrees C in this process, the matter is generally fixed.

### USES OF THE WHITE PHILOSOPHERS STONE

Even if not multiplied it is a certain maximum sephirothic level. White stones go up to level 7 (Netzach), red stones to 6, 5, and 4 (Tiphareth, Geburah, Chesed). It is a medicine of the heart and soul, giving initiatic experiences. In an alcoholic distillation (?) it gives initiatic experiences on Yesod (level 9). If multiplied once, it gives experiences on Hod (level 8), and multiplied again on Netzach (level 7). This only applies to the alchemist who made the stone. For others there will be light experiences, conscious dreams, but significant healing effects.

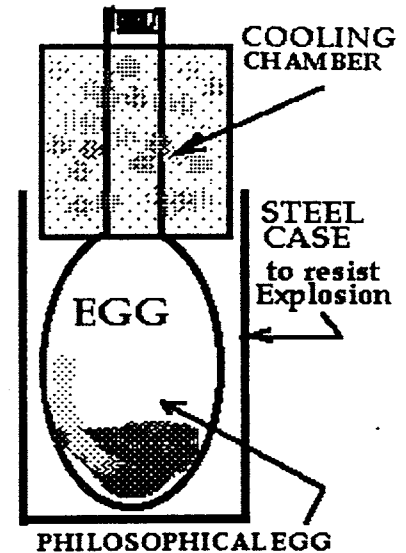

### CAUTION

The sulphur of gold (gold tincture) can cure many illnesses. Even in homeopathic dilution, it modifies the blood. One should be careful with gold preparations. If AuCl<sub>3</sub> (gold chloride) was used in the preparation, it can be very toxic. Native gold should be used, and the tincture dispensed homeopathically.

*Since giving this lecture and returning to France, Jean has begun seminars on the topic on France. Further, he plans to write a series of lessons on the acetate path. I apologize for the number of 'holes' in the notes which relate to the distillation of the acetate. The processes were not unlike those already known to me in those particulars, so I was not taking detailed notes on that aspect of the work.*

# THE OPERATIVE COUPLING OF THE ZODIACAL SIGNS

*by Wade*

When I was doing a meditation on the significance and meaning of the symbol of six contiguous circles of equal sizes surrounding a central circle of the same size, I came across this chapter in Dane Rudhyar's book ASTROLOGICAL MANDALA. The following "essay" is an abbreviation of this chapter.

The zodiacal wheel can be divided into 6 pairs. Relatively speaking, 6 masculine signs or root symbols, and 6 feminine signs or symbols or conformation. For this discussion, we will be looking at signs following a time-sequence which constitute an operative coupling. These are: Aries/Taurus, Gemini/Cancer, Leo/Virgo, Libra/Scorpio, Sagittarius/Capricorn, and Aquarius/Pisces. This arrangement suggest a sequence in time compared to the polar opposite signs (Aries/Libra, Taurus/Scorpio, etc.) which refers to a sequence in space, the division of a circle into two semicircles, a geometrical division.

The masculine signs refer to six fundamental modes of operation of the one Life-power. Together with the feminine signs, they characterize broadly the pairs of signs (zygygies) which divide the whole zodiacal process into six periods. That is, as the entire cycle of transformation proceeds and six great purposes are being worked out in sequence. These are:

1. EMERGENCE from the unmanifest, the great Waters of Space, or Chaos (Aries/Taurus).
2. What has emerged has to pass through a period of UNFOLDMENT of its original potential of being (Gemini/Cancer).
3. Then follows a period of EXPRESSION of this potential in its creative (Leo) and structural-technical (Virgo) aspects.
4. With the original potential of being expressed, a new level of realization and experience is reached, and the stage of REORIENTATION in terms of new values and the new reality of that level (Libra/Scorpio).
5. The next step, COORDINATION, implies a new type of operation or of mode of power within a group (Sagittarius/Capricorn).
6. Then the symbolic COMING TO SEED (Aquarius/Pisces).

The central circle refers to the "self" in the word self consciousness. It is the experincer. The 6 surrounding circles in the geometrical symbol represent the basic power of this experincer, the six essential ways we can not only experience our environment at all levels, biological-psychic, individual-mental, spiritual-collective, but can respond to these impacts made upon us by our environment.

There is always a degree of uniqueness in the responses of an individualized person, but even more important is the fact that the individual consciously uses power (in Sanskrit, shakti) rather than merely releasing energy. Power comes from a center; energy may be released from any place at which an impact has been registered by appropriate senses and nerve centers.

These modes of power are further described in the operative couples described below.

## 1. ARIES/TAURUS

Aries symbolizes the initial emergence of the individual consciousness from the seas of subconsciousness. It is the outgoing, ordered, cyclic motion, emanating from the Primal Will.

Once the focused spiritual impulse (Aries) emerges from the enveloping matrix, it needs Taurus to confirm or give substantial firmness to its fiery impulse toward individualized existence in a clearly bounded and well defined field of activity. Aries needs Taurus as a male needs a female, as a highly projective type of activity requires a bending along a circular path to establishes a boundary for personalized living and experiences.

These two signs constitute an operative couple, and begins the process which leads to the establishment of stable forms of existence. In the occult philosophy of India, this mode of operation of the universal Life power relates to Parazshakti, which can be defined as "the great or supreme force or power." It includes the power of light and heat. Light and heat are the two primordial aspects of the cosmic power which is behind the will to be of any living organism. "To be" means also "to radiate"; the quality of any being is demonstrated by the character of its radiations.

## 2. GEMINI/CANCER

The initial impulse of Spirit into the physical universe has now been established in the Aries/Taurus zyzygy. With Gemini we come to a phase of revelation of potentialities of existence previously hidden to the consciousness. Thus Gemini represents an avidity for experiences and knowledge of all kinds. The Gemini power deals with the interpretation, association, and classification of sensations and concepts.

Cancer phase seeks to establish of persisting and permanent connection between sensations and ideas that were formed in Gemini. In the case of sensations, these connections produce the notion of objects; in the case of ideas, the notion of a permanent identity or self. The Cancer phase reveals the progressive unfoldment of the potentialities of the human-individual as we seek periodically to re form the standards upon which we have built a sense of self and a orientation toward life in general. A man is what he "thinks in his heart," says the Bible. Gemini "thinks," but Cancer establishes a certain category of thinking in the "heart," and makes it a persisting and permanent keystone for the personal life. There is no unfoldment of being except through these two phases of individual existence: the creation of thought categories and of personal standards. Knowledge and self realization are forms that this power takes.

This period of unfoldment corresponds to the Power called Gnanashakti in Sanskrit. It roughly corresponds to the two aspects of human personality known as selfconsciousness and subconsciousness which are symbolized by the planets which rule these two signs, Mercury (Gemini) and the Moon (Cancer).

When under the influence or control of material conditions, the power represent by this zyzygy manifest as:

- a. the power of the mind in interpreting our sensations;
- b. its power in recalling past ideas (memory) and raising future expectations;
- c. its power as exhibited as "the laws of association" which enables it to form persisting connections between various groups of sensations and possibilities of sensations, and thus to generate the notion or idea of an external object;
- d. its power in connecting our ideas together by the mysterious link of memory and in thus generating the notion of self or individuality.

When liberated from the bonds of matter, some of the manifestations of this shakti are real clairvoyance and psychometry.

## 3. LEO/VIRGO

With Leo we come to man's characteristic capacity for self expression. But human evolution requires not only the exercise of the power of self expression (Leo), but of the power of selective self expression (Virgo). Virgo symbolizes an idealized expression born of creative vision and of an individualized piercing through appearances. Virgo deals with the establishment of a conscious and individual standard of values thus with the discriminatory faculty. Self expression (Leo) must always be united with discrimination (Virgo) if the individual is to fulfill the basic meaning of Man.

This differentiation of the one original Life-power is called Ichchashakti in Sanskrit, "the power of will." According to Subba Row, "It's most ordinary manifestation is the generation of certain nerve currents which set in motion such muscles as are required for the accomplishment of the desired object."

## 4. LIBRA/SCORPIO

With the zyzygy of Libra and Scorpio we reach a period of reorientation (literally, a new east). The rising Sun in the east always symbolizes the source of power and vitality. This new power is the power generated by permanent patterns of interpersonal social and cultural relationships. But in order to be of permanent value any communal enterprise must be the incorporation of an archetype, or an ideal that serves an evolutionary purpose. Thus the basic need is to visualize the archetype.

The effective visualization of an archetype (Libra) requires not only concentrated attention, but a deep feeling urge. This is where the Scorpio phase of the process comes in. The new step must be experienced in the depth of one's being, physically and emotionally. One may visualize an ideal personal relationship, civilization, or at a higher level, a true occult Brotherhood. But one has to feel (Scorpio) in some way a deeply personal experience, perhaps a very vivid, unforgettable dream, if the ideal is to become an reality.

The Sanskrit term for this power is Kriyashakti: "The mysterious power of thought which enables it to produce external, perceptible, phenomenal results by its own inherent energy." And Subba Row adds: "The ancients held that any idea will manifest itself externally if one's attention is deeply concentrated upon it... A yogi generally performs his wonders by means of Ichchashakti and Kriyashakti."

## 5. SAGITTARIUS/CAPRICORN

Sagittarius seeks to find meaning to those experiences created in the Libra/Scorpio zzygy. It seeks to gain the necessary experiences to expand its view of the world and relationship within a greater social whole.

Capricorn corresponds to the winter solstice, the shortest day of the year. It is when the in-gathering forces of nature are at their apex. Capricorn gathers its forces by focalizing its activities upon practical, social, and political affairs, for the perfection of the social, and in some individuals, the spiritual entity.

The need for the expanded self awareness that began in Sagittarius is confirmed by Capricorn, which seeks to focalize the activities generated in Sagittarius into practical concrete forms and structures. Thus Sagittarius, with its operative polarity, Capricorn, reveals to us the need to achieve a stable and organic coordination of all the elements of the personality. In order to build an at least relatively permanent whole, the interactions between all the interdependent parts of this whole whether they are cells and nerve centers in a human body, or individuals in a national state, must operate on a harmonious and steady basis.

This coordination leads to a centralization of power through some form of leadership. The occult power related to this period is Kundalinishakti. It is the universal life principle which everywhere manifests itself in nature. This force includes in itself the two great forces of attraction and repulsion, such as electricity and magnetism. This is the power or force which brings about the continuous adjustment of internal relations to external relations which is the essence of life, according to Herbert Spencer.

In Yoga, Kundalini is referred to as a force coiled at the base of the spine within the Root chakra (center) named Muladara and controlled by Saturn. The universal life principle, after having expressed a particular aspect of itself in a human body, exists in this chakra still in its universal nature, but "asleep." When it is fully reawakened it is said to rise along the central channel of the spine (sushumna), drawing to itself the vital energies of every cell and organ of the body, which then appears to be lifeless. The rising of life currents to the head center (Ajna) polarizes the descent of a spiritual force, and the individualized consciousness is said to become universalized, at least to some degree. This "divine marriage" within the head releases a mysterious "ambrosia" which in flowing down through the cerebrospinal fluid is said to regenerate the whole organism.

## 6. AQUARIUS/PISCES

Aquarius seeks to give concrete expression to the archetypes of their society by preserving those cultural products that are created during the great period of a society. Works of art and literature immortalize the culture which produced them, thus establishing its meaning and function within "the Universal Community of Man." A society experiences its "coming to seed."

If Aquarius is the coming to seed, then Pisces is the harvest. At the close of the cycle consciousness and activity are poised midway between past and future. The cycle beginning in Aries, now reaches a culmination in Pisces.

The Word in the beginning (Gospel of John) is the germinating seed, a seed which was the product of the previous cosmic cycle and which is sown in a new field of Space, creating the matrix for a new universe. A creative word or tone, a mantra, produces a new field of Space in which a new spiritual impulse can have its germinal beginning. At the social and cultural level, this power of the creative word refers to the symbol releasing utterances and acts of "seed men."

The power related to this phase of activity is Matrikashakti.

This is the force or power of letters or speech, or music. The power of the Word which Jesus Christ speaks of is a manifestation of this shakti. The influence of music is one of its ordinary manifestations.

Where there is a center, an experiencer, there also is the capacity to use power, and to use it meaningfully, for different purposes and, as evolution proceeds, at different levels. As an individual EMERGES from the unmanifest, they radiate the power of life, as consciousness (self-consciousness and subconsciousness) UNFOLDS, we learn to EXPRESS ourselves through the power of will. In preparation for the path of return, we REORIENTATE through the expression of the ideals which we feel deeply for. In order to manifest these ideals, an individual undergoes subtle alterations to COORDINATE the actions within a larger social whole and within our own bodies'. And finally, at the close of a cycle, man uses the power of the word to sow the SEED for the new cycle.

[Dane Rudyhur Astrological Mandala, Chapter 1, Binary Relationships Between Zodiacal Signs.]





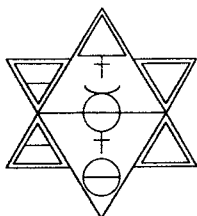

## The Philosophers of Nature

Research and Seminars Group

○ South 651 Jefferson Street

Winfield, IL 60190 USA

Dear Friend in the Work,

We think that the following news regarding a major seminar will be of interest to you, and we are making an effort to let you know about the event now, so that you can begin making arrangements to attend. We are still working out many of the details regarding the event, and will be making some exciting announcements within 2 weeks. At that time you will receive a registration packet and full details about the program.



## The Philosophers of Nature Seminar

September 12-16, 1994

at the Wild Rose Girl Scout Camp,

St. Charles, Illinois

**This event will be the first major seminar sponsored by The Philosophers of Nature, with instruction by members of the English-language organization. The first three days will offer practical programs for those just beginning practical work in Alchemy, as well as separate programs for the experienced worker. On Thursday and Friday, Jean Dubuis, founding president of LPN will be our esteemed guest lecturer. New breakthroughs will be announced at the seminar, which will be of interest to those on the Path of Return.**

The content of workshops which were previously held in the US were determined primarily by the officers of LPN France. This was suitable, in that there was a desire to communicate a body of information, as well as a way of working and a 'world view' which would form the basis of further communication between the researchers in the US and in Europe. This seminar signals that the members of the English language organization, The Philosophers of Nature, will begin to construct educational and research programs of their own. We have many experienced workers who are capable of making lasting contributions in this area. It has always been the goal of LPN France to have a peer relationship with an organization in the USA, and with an organization which is free and independent, and which respects the ethics of the Invisible Order.

May you find Inner Freedom as you tread the Path of Return,

Russell House

Coordinator of Seminars and Research

# THE CURRENTS OF THE CUBE OF SPACE

an excerpt from the book *The Cube Of Space*  
by *Kevin Townley*

One has choices at certain times as to which of the exterior lines of the cube they will travel. It is much like traveling on a river. There are currents to deal with, eddies to rest in, and inlets to explore. In certain places, you must simply follow the current and face the experience. On the exterior of the Cube, there are various directions in which the energy flows. The following diagram shows this movement.

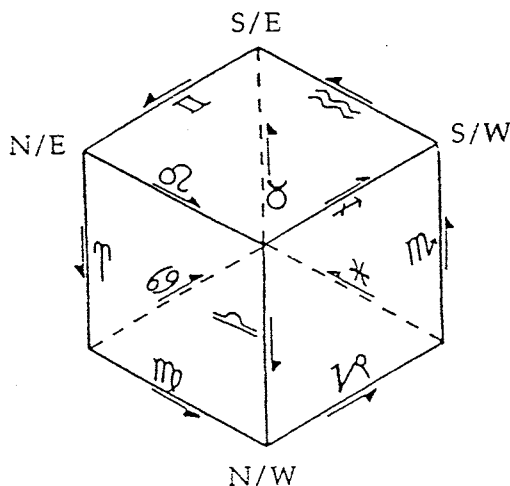

*The Currents of the Cube of Space*

On the above face of the Cube, the energy flow moves in a counterclockwise direction. The eastern face flows in a clockwise direction. The northern, southern and western faces take on a different movement. On the northern face the above and below line flow from east to west. The northeast and northwest line descend from above to the below. In the southern face, the above and below lines flow from west to east. The southwest and southeast lines ascend from the below to the above. The western face has the above and below lines flowing from the north to the south. Since the northwest, and southwest lines have already been explained, we can see that the west has an ascending and descending line. Descending in the north and ascending in the south.

It is on the bottom face of the Cube that challenges come to light. The flow of energy moves in a clockwise direction from the north below line to the west and then to the south. It is the east below line which breaks the flow of energy, for it moves counterclockwise, from north to south.

What does all of this mean? It is the ride on the river of life, and the path of return. You can at times choose which river you want to travel, but you must follow its currents and go where it leads. In some cases, you need to travel a couple of different rivers in order to get to the one you are seeking. Each river has its own challenges. Some are easier to travel than others. Some bring us face to face with our fears of separation and death.

In dealing with the Cube as an evolutionary process, we must travel all of its rivers in order to get to the source.

We have become self-conscious beings since our biting into the apple in the Garden of Eden. The above face represents the self-conscious state. It is here that we begin our journey to the center. The four lines that bind the above face of the Cube take us around and around until we choose to accelerate our evolutionary process. Once we do this, we are never the same.

When we hear the calling, and choose to make a difference in our lives, we descend into the subconscious world of memory, and return into consciousness with the gems that await the courageous traveler. When we choose to jump into the river, we begin the most exciting journey there is, the path of return to the Most High.

There are two places where we can gain access to our subconscious levels. They are located on the northeast and northwest corners on the Cube. These are the zodiacal signs of Aries and Libra.

Imagine it is the twenty-second of March, the time when the Sun enters the sign of Aries and the Vernal Equinox. At this time, the Earth's energies are in balance and a new zodiacal year begins. If we were to take this point of time and refer to the Cube, we would find ourselves at the northeast above corner. Here is a place to begin our descent, our wanderings around the boundaries of the Cube. This is a crucial point on the Cube, for the energy flow can either take us down into the lower face or allow us to continue to circumnavigate the above face. If we refer to the diagrams that show the Cube's energy flow, we can begin to map out our journey.

As we descend the northeast line, we arrive at a point of choice. We can travel from east to west via the path of Yod, Key 9, The Hermit, and the astrological sign of Virgo; the other choice is to travel from north to south, through the current of Cheth, Key 7 the Chariot, and the sign of Cancer. If we choose the line of the north below, Virgo, we must travel through the north face to the western face, and the western face to the southern face. At the southwest corner, we have the opportunity to surface through the sign of Scorpio, for here there is access to the above face. If we continue, we must traverse the southern face traveling from west to east. Here we will be forced to surface due to the merging currents of Cancer and Pisces, which drive all travelers to the surface through the path of Taurus.

The different planetary forces represent our different modes of consciousness. Those familiar with the Tree of Life will already know the attributions given the four cardinal directions, for they are the same as the spheres on the Tree that bear the same planetary name. The north is assigned to Mars, the sphere of Geburah. The east is Venus, assigned to the sphere of Netzach. The west is Jupiter and assigned to the sphere of Chesed. There is a slight difference in the relationship between the Sun assigned to the southern face of the Cube and Hod, which is the sphere on the Tree. For those who wish to challenge this point, the author asks their patience until it is dealt with later on in this text. For now, Hod will gain the association of the southern face. The basic introduction to the Cube is almost complete.

One other major point needs to be addressed: Our journey around the faces of the Cube eventually lead us to the center. This is the goal. Within the interior of the Cube lie four lines that connect each of the four below corners of the Cube to the four above corners diametrically opposed. These diagonal lines correlate to four of the five Final Letters of the Chaldean Aleph-Beth. These four letters take on a special form and significance when they are placed at the end of a word. These are Final Kaph, Nun, Peh, and Tzaddi. It is through these Final Letters, and the path which they represent, that one is able to enter the center of the Cube. When one reaches the center, they have access to any face on the Cube, as did the Divine Father Jah when He sealed the six directions from the center.

The following diagrams show the diagonals moving from the below through the center to the opposite corner.

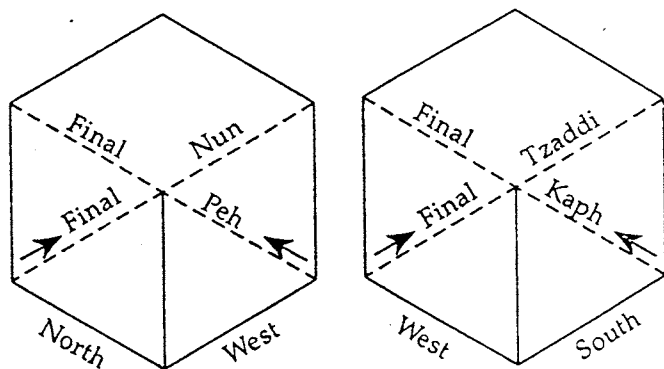

*The four Finals*

The first figure shows the extension of Final Nun moving from the northeast below corner to the southwest above corner. It also shows Final Peh moving from the southwest below corner to the northeast above corner. The second diagram shows Final Tzaddi moving from the northwest below corner to the southeast above corner. Final Kaph ascends from the southeast below corner to the northwest above corner. Each of these diagonals pass through the center of the Cube. The center of the Cube represents the Holy of Holies. From the center, one can see the entire cube and move to any face at will. This is the place of perfection, completion and the "Administrative Intelligence." It is also the place where the fifth Final Letter, Mem, rests.

Together with the letter Tav, they spell the word Toom (TM), meaning completeness, perfection. Toom has a value of 440 when (M) is valued at 40. Also the value of 440 is (ChZChzITH)-wheelings, circling, and (SHKL KLLI) the Collective Intelligence, the intelligence associated with the Sun and the letter Resh. The diagonals are only accessible from the lower faces of the Cube.

To arrive at Final Nun, one only has to descend the northeast line of Aries and take the diagonal to the southwest above face.

To arrive at Final Peh, you would descend the northeast corner, traverse the north below line, then to the west below line until you reach the southwest below corner.

To arrive at Final Kaph, one descends through the northeast corner and one traverses the east below face until arriving at the southeast corner.

To arrive at Final Tzaddi one descends the northeast corner and travels west to the northwest below corner.

Final Mem is at the center. The first of the Final letters is Kaph and it is the first to be traveled. Before one may travel to the center, the western face must be experienced. It is on the west below line that Key 15 lies. Key 15 represents the shadow, The Devil, the dweller on the threshold. The same is true of the other letters. They, too, must be integrated. To arrive at the final letters, one must integrate the regular form of the letter.



# NEWTON AND FLAMEL ON STAR REGULUS OF ANTIMONY AND IRON

by Anthony House

Gale E. Christianson<sup>1</sup> in his scholarly book subtitled "Isaac Newton & His Times," in chapter 9 entitled: *The Treasures of Darkness*, presents excerpts from Newton's alchemical writings.

Principally, the quotations are from the early to late 1670s, focusing specifically on making regulus of iron and antimony to further produce a philosophic double mercury that was animated by several distillations and subsequently caused swelling and putrefaction in gold.

Nicolas Flamel, in his *Breviary*, a division of his book "Abraham the Jew," gives essentially a straightforward description of the same process for the Great Work.

This article will attempt to sort out in part, Newton's path, while also touching upon Robert Boyle's related experiments, and making some comparison to the Flamel Work.

Commentary on these two paths may be helpful to receive some details where they are missing in Newton's writings and in Christianson's additional notions, since some details seem to have their appearance in Flamel's study.

Here in this chapter on Newton's breakthrough experience, is evidenced interesting parallels that also prescribe much of LPN's up-to-date research to convey more fully the apparent omitted details. Including Newton's proportions in the processes to obtain the Starry regulus of antimony and iron; Lunar Regulus, and Lunar Venusian Regulus.

By 1670 Newton's attention had focused on the regulus of antimony, a substance that was to remain near the center of his thoughts for as long as he pursued the hermetic art.

We know antimony as a metallic element, a hard, extremely brittle, glistening, silver-white, crystalline material used in a wide variety of alloys.

N.B. Christianson here speaks as the chemists of our time do by using the term alloys to employ the use of antimony [sulfide] i.e. the ore  $Sb_2S_3$ .

It should however be noted that the iron must not be used in excess, therefore the regulus is not an alloy at any stage.

Christianson's next comments show that it's not the trisulfide we need, but the metal stibnite. LPN has shown that it's necessary to separate the free sulfur from the stibnite by heating the broken up antimony ore in a heat resistant tube where it's melted and dropped as small pellets into distilled water to obtain the desired material for regulus.

To the alchemists, however, antimony was not the metal itself but stibnite, the lead-gray ore from which it was extracted by heating it with charcoal or some other mild reducing agent.

The metallic antimony sinks to the bottom, and this (our element) is what the alchemists called the regulus of antimony.

N.B. The last two paragraphs speak of a reducing agent [this should be done in a furnace in a crucible] saltpeter or potassium sodium nitrate acts as a fluxing agent and iron and eventually silver will act as the reducing agents. When the regulus is poured into the warmed mold the metal sinks down [you may tap on the mold with a hammer to help it sink down to the bottom while the scoria solidifies as it cools on top of the metal.] A button of metal is obtained this way, which must undergo further purifications to reach the star regulus.

The name probably derived from the Latin *regulus*, meaning petty king. Because the regulus of antimony combines readily with gold (the king of metals) it became important to the process of refining the precious metal and an object of considerable experimental interest to seventeenth-century adepts.

The regulus was also separated from stibnite by the introduction of various metallic reducing agents, in which case it became the regulus of Venus (copper), the regulus of Jupiter (tin), the regulus of Saturn (lead), or most importantly, the regulus of Mars (iron).

It was thought, quite erroneously, that the "seed" of the metal used to reduce the regulus from the ore remained embedded in the regulus itself, thus raising all sorts of tantalizing possibilities in Newton's mind.

*N.B. The seed of course is in the scoria and also in minute quantify in the metals applied in the work. The seed is the sperm of the metals and Newton probably knew that he was to locate this seed and to cultivate it; sew it in the Duplex or animated, philosophic mercury.*

*Sewing the seed into the amalgam of this star regulus to which has been added silver; its purification to purple or violet color; additionally triple distilled Hg is incorporated, its then washed and ground, and washed again until it is a pure and shining mirror...the black particles that are washed away from the amalgam is kept for further research.*

The earliest evidence of his interest in the different reguli had surfaced in the form of notes copied into the chemical dictionary between 1666 and 1667.<sup>2</sup> Now, some two years later, the young adept felt sufficiently emboldened to compose his own essay on their preparation. As usual, he wrote with the confidence born of firsthand experience:

Isaac Newton

These rules in general should be observed. 1st if the fire be quick. 2nd if the crucible be thoroughly heated before anything be put in; 3rd if metals be put in successively according to their degree of fusibility [iron], copper, antimony [stibnite], tin, [lead]. 4thly That they stand some time after fusion before they be poured off accordingly to the quantity of regulus they yield [iron] to keep it from hardening. 6th That if you would have the saltpeter flow without too great a heat, you may quicken it by throwing in a little more saltpeter mixed with 1/8 or 1/16 of charcoal finely powdered. End of quote.

*N.B. Clearly Newton had prepared many reguli and had found the right proportions and timings; both by waiting to pour the regulus, and probably discovered the correct appearance of the ready matter and manipulated the technique at the right moment.*

Newton went on to enumerate the many telltale "signes" of failure that, in their turn, had disturbed the rapt tranquillity of his laboratory. But with the perfection of his experimental technique success was soon assured:

Isaac Newton

"Thus with a good quick & smart fire - 4 of [iron] to - 9 of [stibnite] gave a most black & filthy scoria & the Regulus after a purgation or two, starred very well."<sup>3</sup>

*N.B. LPN has suggested several mixes of nitrate and tartrate, purified stibnite, and iron nails. Newton directly refers to the black scoria [the crow] and 2 purgations (purifications) with the potassium nitrate (can take up to 3-4 purifications), that will obtain a 60 degree angled star. Note that unless you go over the star you will not have the right regulus for the work.*

The term "starred" was here employed by Newton in its most literal sense. For if the antimony has been properly purified as in this instance, it forms long and slender crystals. During cooling the crystals in turn form triangular branches around a central point, taking on the aspect of a silver star.

Masters of the symbolic, the alchemists named this heart of antimony ore after Regulus, the bright double star near the heart of the constellation Leo. When the star regulus of antimony was achieved with the aid of a metallic reducing agent in the above experiment, Newton had produced the star regulus of Mars.

Further confirmation of his success is contained in a letter to Oldenburg of January 1672: "What the stellate Regulus of Mars (which I have sometimes used)...will do" as a reflecting mirror in a telescope "deserves particular examination."<sup>4</sup> Yet it was for profounder reasons that the fashioning of better telescope mirrors that Newton long remained concerned.

*N.B. To obtain a very shining mirror-like surface Newton must have found just the right mixture, thus using silver he obtained the Lunar regulus. Newton and Flamel amalgamated this regulus with thrice distilled mercury. Once washed, it is a reflecting mirror.*

At exactly what point and under what circumstances Newton began to contemplate seriously the principle of attraction between physical bodies is impossible to say. The general idea of gravity, though far from well developed, is certainly hinted at in the "Hypothesis of Light," the controversial paper he sent to the Royal Society in December 1675. It has been observed that the lines of crystals that appeared to radiate out from the center of the star regulus "might just as well be considered as radiating into the center, which gives them the character of attraction rather than the character of emission."

If, indeed, Newton viewed the star regulus in this light, then the very concept of gravitation "in which the lines of attraction run in to and converge in a center point" may have suggested itself to him.<sup>5</sup>

Present in this diminutive terrestrial orb was the invisible cosmic glue that binds the planets to the stars and the solar systems to the galaxies of the macrocosm. Most probably, however, the idea of gravitation had not taken such definite form in Newton's mind in the early 1670s, though there is no question that at its roots eventually found ready nourishment in the fertile field of his alchemical thought.

*N.B. It's extremely interesting to note that gravity is compared to the central point of geometric crystallization. Newton must have recognized as Flamel did that through the numerous 7-9 eagles or distillations that the crystalline structure of the regulus amalgam was progressively adjusting and rising in a set pattern towards a cubic fundamental matrix. Above this pattern is the absolute or inter atomic energy which surpasses the atomic material energy. To distill the amalgam above 9 times generally leads to an explosion. The cubic structure is the most perfect of the crystals having perfect right angles and equilateral triangles in its arrangement. This matter is the seed risen to its highest purity.*

Nor, if Newton's notes on Basil Valentine are accepted at face value, did he mistake the star regulus for the philosopher's stone, as had more than a few bedazzled adepts.<sup>6</sup> Instead, Newton looked upon the star as a most promising step in the creation of the philosophical mercury, the *materia prima* or first matter from which all substances are formed.

*Robert Boyle obviously experimented much with the reguli, including the regulus of antimony and iron.*

Excerpt from text on British Royal Society:

Robert Boyle, in his book "On Unsuccessfulness of Experiments"<sup>7</sup> says: "And it may perhaps also be from some diversity either in antimonies or irons, that eminent scientists (chemists) have (as we have observed) *often failed* in their endeavors to make the starry regulus of Mars and Antimony.

In so much that diverse artists fondly believe and teach (what our experience will not permit us to allow) that there is a certain *respect to times and constellations requisite* to the producing of this (I confess admirable) body."

*N.B. On a clear, unclouded, and windless day, the regulus will become starred quite easily when you're ready, and sufficiently skilled in the process. The clear weather helps considerably, but then so does the bond between the matters and the operator.*

In the mid-1670s, Newton composed a paper of some 1,200 words entitled "Clavis" (The Key"). This intriguing document, so concise and polished, gives evidence of being the last in a succession of drafts, the compilation of which had by then become one of Newton's distinctive intellectual trademarks.

The contents represent the distillate of years already spent in the meticulous study of the star reguli in the hope of extracting philosophical mercury from common metals. It was clearly Newton's belief that he had succeeded in doing just that.

*N.B. It was not extracting philosophic mercury from common metals that Isaac Newton was after, but THE Philosophic Mercury or amalgam that would make the little trees of tiny crystalline branches grow, the sophic gold, so that he could bathe his gold in it, to multiply it, and animate it, for its magical properties.*

Newton began with the star regulus of Mars (Iron). which was fused with a small quantity of pure silver, the "Doves of Diana." To this he added common mercury, amalgamating the mixture in a sealed vessel over a "slow fire." The amalgam was then ground for "1/8 of an hour in a mortar...until it spits out its blackness."

Repeated flushings, grindings, and washings left an alloy "like shining and cuppelled silver." A series of seven to nine more distillations and washings produced a mercury seemingly capable of dissolving all metals, especially intractable gold. The *cauda pavonis*, the multicolored tail of the peacock described by ancient alchemists, unfolded before Newton's very eyes:

*N.B. Note that Nicolas Flamel experienced the same things while manipulating the amalgam, the gold, and the silver. Below Newton writes:*

Isaac Newton

"I know whereof I write, for I have in the fire manifold glasses with gold and this mercury. They grow in these glasses in the form of a tree, and by a continued circulation the trees are dissolved again with the work into a new mercury. I have such a vessel in the fire with gold thus dissolved, but extrinsically and intrinsically into a mercury as living and mobile as any mercury found in the world. For it makes gold begin to swell, to be swollen, and to putrefy, and to spring forth into sprouts and branches, changing colors daily, the appearances of which fascinate me every day. I reckon this is a great secret in Alchemy."

---

### The Philosophers Of Nature

excerpt from Guelph, Ontario, Canada, 1992.

Martial Regulus is not good enough...

We can make an amalgam of [Star] Regulus and silver which equals the Lunar Regulus, or a [Star] Regulus of silver and copper which = the Lunar Venusian Regulus. When this last amalgam Lunar Venusian Regulus is well prepared it is a light purple color.

Make a fine powder from this Lunar, or Lunar Venusian Regulus, add triple distilled Mercury (i.e. distilled Hg, caution must be exercised when handling Hg, even when cold its vapors are very toxic), and place the fine powder with the triple distilled {Hg} mercury into a tumbler to mix together thoroughly.

When you stop the tumbler, (leave on for 12 hours) you will have a butter [e.g. a buttery-like amalgam].

**Note:** Remove the butter from the tumbler with (surgical) rubber gloves and wear goggles (caution - this butter is very corrosive), clean the tumbler with distilled water right away otherwise it hardens in an hour. The water turns black and a black powder forms. Wash the amalgam thoroughly, persist until it is mirror-like. Set this water and black powder aside in dark vessels.

There are three products which can be obtained from these amalgams i.e. sophic mercury, live mercury, and animated mercury.

Distill this amalgam (butter). This [according to Flamel's Breviary] is known as the *Philosophical Sublimations* and the *Chores of Hercules*, or the *Flying of the Seven Eagles*, the result will be an Animated Mercury.

The double mercury or duplex [animated mercury] is then seeded {this is known as *Sowing to obtain the Elixir*.} (note: seeding can be done with the seed contained in the scoria of the first fusion or with live mercury, with animated cinnabar, with native gold, the black powder, or live sulfur) and place into an incubator.

*Obtaining the Elixir* is when the colors come; black; white; orange; red.

At this high stage of the work *Multiplication* becomes a next step using the red stone in the same fire and same vessel and animated mercury.



Then comes the *Revolutions of the Wheel* where the power of the red stone increases by powers of ten. Even leading to an eternal lamp diffusing an eternal light...

## CARES TO BE TAKEN FOR THE AMALGAM

1. Proportions: The triple distilled mercury Hg weight will be from 3 to 5 times the Lunar Venusian Regulus weight, generally.

2. Proportions are not crucial, as the animation occurs during the successive eagles. At each eagle (distillation) the mercury animates by taking the metallic life from antimony through silver (the medium silver is a transfer metal, the transfer occurs when the metals are melted). Absorption of the energy is more important in the first eagles than in the latter. In an eagle the life of the regulus weakens silver this is called the Dead Doves of Diana, and this same silver can be used indefinitely for more amalgams. An eagle means: amalgam with mercury Hg, and regulus and distillation of the amalgam.

The dissolution of gold, not its multiplication, is what most interested Isaac Newton. He measured the magnitude of his supposed achievement against Boyle's oft-repeated alchemical dictum: "It is easier to make gold than to destroy it." In other words, once someone has solved the knotty riddle of what a substance is made of, producing that substance should be comparatively easy, a familiar enough notion to the student of modern chemistry.<sup>8</sup>

Newton's pursuit of the true philosophical mercury had caused him to draw heavily upon the works of George Starkey, who, as previously noted, published under the pseudonym Eireanaeus Philalethes. Nine of Starkey's books graced the shelves of Newton's library when he died, a number matched only by the indispensable treatises of Count Michael Maier.<sup>9</sup> The mediation of special mercuries were set forth in a manner strikingly similar to those expressed by Newton in the "Clavis" manuscript.<sup>10</sup> Moreover, Starkey sought to put this knowledge to a practical use by effecting the process of transmutation.

*N.B. Philalethes gives the process for making regulus and amalgam that Newton and Flamel do. It being so similar that without doubt Newton knew that Starkey was an adept in the work, and after reading an article published by Oldenburg, and written by Robert Boyle in the Philosophical Transactions of the Royal Society entitled "Of the Incalcescence of Quicksilver with Gold, generously supplied by B.R.":*

Newton, who did not get around to reading his issue of the transactions until April 1676, had no trouble identifying the author as Robert Boyle. Boyle wrote of having discovered a special mercury that grows hot (incalcescent) when mixed with gold. He considered it a breakthrough in the preparation of medicines, but he was also wary of the great harm its disclosure might do. For if Boyle had refined a true philosophical mercury, a discovery Newton privately claimed as his own, it could be used by "ill hands" to multiply gold, thus lifting the lid from a Pandora's box of endless "political inconveniences."

Boyle sought advice from the "wise and skilful" as to whether he should make known to the world the specific ingredients of his recipe for the mercury.<sup>11</sup>

Newton, it seems was the only adept who chose to reply, at least in writing [to Oldenburg]. He cautioned Oldenburg to "keep this letter private to your self."

His usual desire for secrecy was underscored by the knowledge that the attempted transmutation of metals was legally punishable by hanging. As an alchemist, Newton could not but question Boyle's optimistic conclusion regarding the mercury. He had explored methods similar to Boyle's, only to abandon them for more encouraging prospects. Still, Newton counseled caution, partly perhaps to avoid alienating a respected colleague, and partly because Boyle might know more than he had let on:

Isaac Newton to Oldenburg

"It may possibly be an inlet to something more noble, not to be communicated without immense damage to the world if there should be any verity in the Hermetic writers, therefore I question not but that the great wisdom of the noble Author will sway him to high silence till he shall be resolved of what consequence the thing may be either by his own experience, or the judgment of some other...that is of a true Hermetic Philosopher... there being other things beside the transmutation of metals (if those great pretenders brag not) which none but they understand." End of quote.

While Newton doubtless shared Boyle's concern for the dire economic and social consequences that must follow from an easy transmutation, one senses that this cautionary advice was rooted in other than altruistic grounds.

No common "goldmaker," Newton's personal anxiety surfaced when he employed the self-revealing phrase "there being other things beside transmutation of metals." If Boyle were to disclose this great secret of the ancients, Newton's belief in his special relationship with the Almighty must suffer irreparable harm. The gates of the *prisca sapientia* would have been breached, and to the vulgar materialists would belong the desecrated spoils.

*N.B. Newton, like all true adepts of alchemy revered the Most High and Divine Will of God. Boyle may too have held a faith denying the philosophy of the times that Descartes put forth, "separating body from spirit in nature, to deny, as it were, that any "occult" forces, such as attraction and repulsion, are manifest in this great chain of creation. Though a mechanist tried and true, Newton could never be persuaded that spirit was absent from the operations of nature."*

As a member of the inner circle that directed the general course of Royal Society activities, Boyle was surely aware of Newton's reticence in scientific correspondence. Yet it seems doubtful that Boyle was taken aback when Oldenburg informed him of the Lucasian Professor's response to his recent paper.

Indeed, he had good reason to think that his newfound friend might have written even more.

Boyle, after all, was the seventeenth century's most astute practitioner of "chymistry," and he had been present some months earlier during the reading of Newton's much-debated "Hypothesis of Light." Interpreted by most as the treatise on mechanical philosophy Newton meant it to be, the paper's equally profound if veiled alchemical implications could hardly have escaped Boyle, especially considering that Newton accepted and elaborated on a number of his ideas.

*The study of alchemy for spiritual quickening lost its romance and adventure in the 17th century, particularly for the vogue chemists that would turn away from the past to embrace an unknown but promising future of enterprise and commerce.*

*Robert Boyle and Isaac Newton were two individuals important to the art in a century replete with nascent discovery. Just as was Nicolas Flamel in the 14th century a man of invention and discovery.*

*This renaissance period of practicality, inspired men of conscience to the design of the Royal Society's objectives:*

"The business and design of the Royal Society," as Robert Hooke wrote, is "to attempt the recovery of such allowable arts and inventions as are lost," and "to examine all systems, theories, principles, hypotheses, elements, histories, and experiments of things natural, mathematical and mechanical, invented, recorded, or practiced by any considerable authors ancient or modern." Nor will the Society "own any hypothesis" until "by mature debate and clear arguments, chiefly such as are deduced from legitimate experiments, the truth of such experiments be demonstrated invincibly."



#### REFERENCES

1. Free Press, 1984 In the Presence of the Creator.
2. MS. Don. b. 15, ff. 4v-5r
3. U.L.C. ADD. ms. 3975, p. 82.
4. I.N. Corres., 1:82.
5. B.J.T.D., p. 150.
6. Keynes MS. 64, f. 4r.
7. Opera, ed. 1772 i, 325.
8. B.J.T.D., p. 185.

9. J.R.H., pp. 65, 215, 243

10. One student of Newton's alchemy has argued that he probably copied "Clavis" from a lost manuscript of Starkey. Karen Figala, "Newton as Alchemist," History of Science, XV (1977): 107. For an opposite view, see Richard S. Westfall, "The Role of Alchemy in Newton's Career," p. 207, and B.J.T.D., pp. 175-78.

11. Philosophical Transactions, X (1675-76): 515-33.

## SEMINAR VIDEOTAPES AVAILABLE

*The first and second Philosophers of Nature Seminars were video recorded and the videotapes are now available.*

### A. Video recording of 1st Philosophers of Nature Seminar - 2, 3, & 4th October 1992.

Contents of package:

1. Three video cassettes (Over 15 hours of material).
2. Table of contents of the videotapes, keyed to time for quick searches (if your VCR tracks time).
3. Complete graphs and written material provided by LPN France on subjects covered in the seminar.  
Price = \$69.95, post paid.

### B. Video recording of 2nd Philosophers of Nature Seminar - 23 & 24 of April 1993.

Contents of package:

1. Two video cassettes (9 1/2 hours)
2. Table of contents of videotapes.
3. Complete graphs and written material provided by LPN France on subjects covered in the seminar.  
Price = \$49.95 post paid.

# A JOURNEY TO FRANCE.

by Russ House

During the fall of last year, Sue and I visited with many members of the organization in France. While this was an "unofficial" visit and was a vacation for us, we were readily welcomed by the members and officers of LPN-France. We saw everyone who has come from LPN-France to the U.S.

We also attended the annual General Assembly of LPN-France in Paris. At that meeting, I presented to Jean Dubuis and Marc-Gerald Cibarc, respectively the founding president and the current president of LPN-France, enameled lapel pins depicting the flags of the USA and France. This was a symbolic gift from the board members of The Philosophers of Nature, indicating our desire for the continued cooperation of our organizations, for the common good of humanity.

During our visit we saw evidence of the continued interest in the development of a sound organization in the U.S. Recent board meetings with the other officers have confirmed that much progress has been made to meet organizational goals which will permit even greater things for the members in this country.

The board of The Philosophers of Nature met with officers of LPN-France during the first quarter of the year to review this progress.

## RESEARCH CONDITIONS IN FRANCE

In Paris, generally, apartments and homes are small. The laboratory of a researcher is often smaller than a normal desk top. Patrice Maleze and his wife, Lisette, have a sizeable laboratory, where Etienne and Lucille Gerbaut come to work from time to time. Patrice is currently working on a project fusing antimony regulus and living sulphur in a closed crucible at 640 degrees C. Lisette has made numerous plant stones using sea salt. Among the most fragrant creations is a stone of garlic. Another stone of nutmeg is in the works at present. At their place I saw an apparatus which yields 93 to 94% pure spirit of wine from the FIRST distillation of red wine. I set up a similar apparatus at home and obtained the same results.

Lucille Gerbaut, has a beautiful apartment in Paris and among the elegant decorations, one finds displays of large, perfectly formed crystals of all colors...grown by Lucille. She keeps her distillation apparatus in a closet on a rolling TV table, so that she can locate it near the sink for cooling the condensers, and then, disconnect it and conceal the equipment when the process is complete.

South of Paris, in Malesherbes, Jean has a rather large alchemical laboratory and an additional electronics lab in his home, where he works with new techniques that are communicated to members in France and abroad. Etienne Cornaille often works at Jean's place to build electrical furnaces and distilling equipment. He also maintains a personal lab in his kitchen in his Parisian apartment.

An avid researcher, Michel Auger works in a tiny space in Brittany and performs "miracles" according to his peers. He is working on numerous

projects, including a rather lengthy path using butter of antimony where every material is living. We were unable to visit him this trip, but met with Michel and his wife, at the general assembly.

In Toulouse, in the far south of France, we visited the well equipped laboratory of Gilbert S., a retired electronics expert. Many ingenious devices that he has designed were in evidence. He gave us some nearly perfect, quite clear crystals of the "salt of sulphur" of caraway. These were obtained by the water used to steam distill the seeds of the plant, the water having been filtered, evaporated and the resulting material recrystallized many times.

Marc-Gerald's place is a veritable warehouse, as it is the central distribution site for lab equipment and supplies for their large research team. He has set up a very efficient office for the LPN there as well.



## Something Weird...

Something weird happened in this issue of The Stone; for some yet unexplainable reason our desktop publishing program chose to replace the oft used dash "-" with question marks "?." We have tried to correct this problem, but if you find any "?" between words, realize that we are not trying to confuse you, it was an oversight on our editorial staff (who all have beady bloodshot eyes at this point, having stared for seeming endless hours at the computer screen!) Thanks for your understanding.

# The Letter of Jean DuBuis: The Walk In the Woods

(from *Le Petite Philosophe de la Nature* June/July, 1993)

Translated by Ridgely Hunt

Why do the teachings of the LPN tell us to take a walk in the woods?

LPN is an evolving association, and we always listen to the experiences of our members in deciding its direction.

At the beginning of the LPN we had oriented our course towards personal Initiation. But, in fact, we think that for a certain number of our members, orientation towards an interior contact is preferable.

What then is the difference between Initiation and interior contact?

Initiation gives to the consciousness the mastery of access to a sphirotic level higher than that of Malkuth.

The mastery of a certain level implies that the one who can elevate his consciousness to it is in possession of its powers.

These are described in Greek Roman mythology, and, in brief, one can read of the powers of Jupiter; they are those obtained in Chesed. Likewise, those of Mars correspond with Geburah, those of Phoebus Apollo with Tiphareth, of Venus with Netzah, of Mercury with Hod.

It must be understood that access to one of these levels gives Power and Knowledge. Also, those who attain to one of these points need to know the following: having established the contact in question it is important to have prepared by meditation and by concentration on the goal desired, be it his proper growth or be it service.

If one chooses growth, the result of the contact is strictly personal, and must absolutely remain secret.

We will try now to propose to the LPN the methods for interior contact. In these, there is no mastery of the level, nor accession [to its power,] nor for its use.

So far, the results which have been communicated to us following from the proposed experiments have almost all been concerned with the personal growth of the operators.

The interior contact has the advantage of being much easier to obtain than Initiation, and does not necessitate following the normal order of remounting the Sephiroth: the obligatory order in Initiation: Yesod, Hod, Netzah, Tiphareth, Geburah, Chesed, Binah. We have begun to give the methods, at the moment alchemical, permitting the contact of Hod, and, soon, those of Tiphareth and Binah. We are attempting for this to reduce to a minimum the alchemical work necessary, but for those who do not practice this Art, we propose a walk in the woods.

When I was between five and twelve years old, I lived near a forest of oaks, and walking in it was, for me at the time, a source of fear and a "splendid state".

The forest is a place where the "vegetable power manifests itself".

The forest of my childhood was a forest of oaks, the king of the forest, the tree of the druids and of the alchemist URBIGER.

Seek a forest of oaks and go lean against one of them, facing the East, on Saturday morning at sunrise or in the instants following. Go, for example, to the forest at Fontainebleau, lean against the Jupiter oak (which is marked on the maps) and await communion with nature.

The probable contact given by the oak is that of Netzah, that of the vegetable nature, first fruits of an initiated departure.

Always be prudent and patient, because Netzah is, in the Astral, the level of waiting, of preparation for the Second Death, but Netzah permits of passing this level without the destruction of the psychic memory.

I wish for you the "dreams" in which you dwell in the great trees.

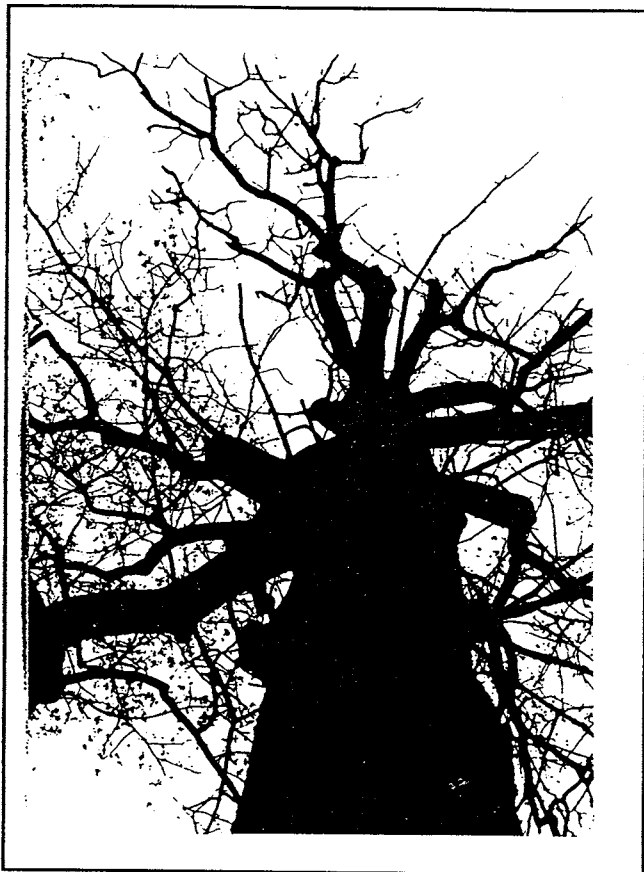

### **Important New Information for Philosophers of Nature (LPN USA) members!**

Now you can talk to a real human being if you have questions or problems with your membership. Office manager Karen High can be reached at (303) 443-8199; you may leave a message for her Monday through Friday from 9am to 5pm Mountain Time.

## **A Visit to the "Jupiter Oak"** *by Russ House*

On my birthday in 1993, my wife and I had the pleasure of riding in the beautiful country south of Paris in the company of Jean Dubuis, his lady Josette, and Salome, the daughter of our friend Etienne Cornaille. Later in the day, Jean would take us to visit an art glass studio, and we would take photographs of "Pierre Belle" (the beautiful stone), a home erected at Tousson by an alchemist in 1782. At this moment, however, we were on our way to the Jupiter Oak at Fontainebleau. It was late October, and the skies were gray, the diffused light adding to the serenity of the forests and fields.

The car parked, we walked along a trail, stopping to admire the obsidian blackness of a shiny scarab that Salome had discovered making its way along the path. Then, Jean lead the way to the clearing in which the Jupiter Oak held court. The tree was immense! The five of us formed a chain around its rugged trunk, and our arms were stretched when the circle was complete.

The Oak had been a focal point for Druidic activities in the past, and now others come to the clearing for their work. A tree nearby bore a large symbol, carved with bold strokes, a blazing circle of 12 points. It appeared to be a relatively recent marking.

The Jupiter Oak last produced fruit in 1983. An estimated 600 years old, the tree dates back to the period when Nicholas and Pernelle Flamel began to commission chapels in Paris. This king of the forest is nearly 115 feet tall, the maximum height for the species. It would find just enough room to stand within the vault of the magnificent cathedral at Chartres. We had clasped hands around a trunk nearly 20 feet in diameter. The portion of the tree above the ground consists of about 1500 cubic feet of wood, of which the trunk is nearly three quarters.

The early Gauls took the oak trees as a symbol of their supreme deity, and both oak and mistletoe were involved in almost all rituals of the Druids. In most European cultures, the oak is associated with thunder gods: to the northern Europeans with Thor, with Zeus and Jupiter by the Greeks and Romans, in Lithuania with Perkunas, and with local thunder deities in Russia and the Slavic countries.

In later times, Cornelius Agrippa and the herbalist Nicholas Culpepper assigned the astrological rulership to Jupiter. Considered a symbol of longevity, masculinity, strength and fertility (through the acorn), the oak is also associated with hospitality. Sue and I will always remember the hospitality of our good friends in France, and our visit to the Jupiter Oak.



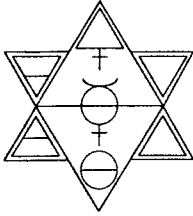

## The Philosophers of Nature

Research and Seminars Group

o South 651 Jefferson Street

Winfield, IL 60190 USA

Jean Dubuis is the Founding President of *Le Philosophes de la Nature* (LPN). He has more than 63 years of esoteric work from which to draw, making him a most interesting man to know. Jean has a solid background in electronics and nuclear physics, as well as many years of work in practical Qabala and Alchemy.

On Monday, March 28, 1994, Jean Dubuis was interviewed by Steven Freier for his radio show, with translations by Patrice Maleze. Steven used a video camera to record the interview, and after the show was aired, The Philosophers of Nature Research Group purchased full rights to the audio and video tapes, so that we can offer these to you. Not only will our members enjoy watching the tape more than once, but they will want to share it with family members and friends.



Jean speaks on many topics of interest, including why Jean founded LPN, the difference between LPN and other esoteric organizations, connections to ancient schools, the lack of hierarchy within LPN, what is Alchemy and why it is important, why Alchemy is well suited for technological societies, practical benefits of alchemical work, how Alchemy and Qabala accelerate our evolution, the need for inner freedom for initiation, differences between inner contact and initiation, humans as gods in the making, relationships of life and consciousness to matter, nature as a creation of man, thoughts on the nature of God, and on Jesus Christ as a model of an initiate on the level of Tiphareth, experiments regarding experiences of Eternity and the associated difficulties, what we can be doing to hasten progress for humanity, spiritual connections between France and the USA, views on disease, and on the opposition to esoteric organizations and their work.



The video tape is in VHS format and is 50 minutes in length. The cost of the tape is \$15. Please add \$3.00 for postage and handling for each tape in the domestic US, and \$6.00 for Canada. Please make checks (in US funds) payable to: **THE PHILOSOPHERS OF NATURE.**

### -----ORDER FORM-----

Mail orders to:

The Philosophers of Nature 0S 651 Jefferson Street Winfield, IL 60190 USA
---

Name: \_\_\_\_\_

Mailing Address: \_\_\_\_\_

City/State/Postal Code: \_\_\_\_\_

Please send \_\_\_\_ copies of the Dubuis Video at \$15.00 each. I have enclosed \$\_\_\_\_ for postage. Illinois residents please add 6.75% sales tax (\$1.00). I have enclosed a check for a total of \$\_\_\_\_. Please allow 2-4 weeks for delivery.

## NEW POLICY ON MEMBERSHIP IN THE PHILOSOPHERS OF NATURE

In the past year the activities of the Philosophers of Nature evolved beyond its original mission as a translation and subscription service into an association with a much more broadly based mix of services. These changes have made obsolete some of the policies and organizational forms we began with seven years ago. One example is that the way we originally dealt with membership in Philosophers of Nature had become inadequate and needed to be revised. The following is an explanation of the new policy in a Question and Answer format. It briefly discusses how one becomes a member, and some of the requirements and benefits to members and or lesson subscribers of the Philosophers of Nature.

Question. How does one become a member of the Philosophers of Nature?

Answer. We have created a new form which is entitled the Membership Application Form ( See attached sample of this form). This form will be provided to those persons who request one. This application will also be made available through mailings, handouts at seminars and other occasions where it seems appropriate. An individual who fills out the application, encloses the dues required, and mails it to our office will become a member for one year (or the portion of the calendar year remaining on the date the membership application is postmarked).

Question. How much are the membership dues per year?

Answer. The membership dues are \$30.00 for the calendar year beginning on January 1st and ending on December 31st. The membership dues for a second member in the same household is \$10.00 per calendar year. The dues are prorated according to the following schedule:

For membership applications postmarked between:		The dues for the year are:
January 1 - March 31	100%	\$30.00
April 1 - June 30	75%	\$22.50
July 1 - September 30	50%	\$15.00
October 1 - December 31	25%	\$ 7.50

Every year in December all members will be mailed a notice reminding them that their membership will expire on December 31st. They will also receive, in that mailing, a new membership application for the upcoming year - which will begin on January 1st..

Question. What material benefits will I receive as a member of Philosophers of Nature?

Answer. A. Members will receive the following:

1. All issues of The Stone newsletter published during their membership period.
2. Those members who subscribe to lessons and sign up to participate in the Research program directed by Russ House will receive the Ora Et Labora newsletter.
3. All mailings and announcements of upcoming events sponsored by the organization.

B. Members will have the right to:

1. Attend seminars and other functions of Philosophers of Nature at reduced Members rates.
2. Subscribe to the courses offered by Philosophers of Nature.



C. Members will have access to :

1. Minerals, herbs, lab supplies etc. at a discount from Triad.
2. Occasional special purchases of used lab ware, bulk minerals, or other items of specific interest to students of the Esoteric sciences at very low cost.

Question. Does this mean that a person must be a member in order to be eligible to subscribe to the course lessons offered by Philosophers of Nature?

Answer. Yes. A person may elect to be a member of Philosophers of Nature in order to receive the newsletters, mailings, attend seminars etc. and yet not subscribe to the course material. However, in order to subscribe to any of the courses offered a person must be a member during the period of the subscription.

Question. How will the money obtained from membership dues be spent?

Answer. The money will go towards paying for the services provided to members such as the cost of producing, printing, and mailing the newsletters, purchase and maintenance of the office equipment, telephone expense, and to defray a portion of the cost to the organization for secretarial services

In addition to the obvious material benefits of being a member of the Philosophers of Nature there are a number of significant but intangible benefits which accrue to members. Three of the most significant are the following:

1. The primary purpose of LPN France/Philosophers of Nature is to discover and then make available to all who are interested the ways and means to accelerate the personal evolution of those on the Path of Return. Given what we know about the life priorities and responsibilities of those on the Path of Return as opposed to those on the Path of Involution it seems very likely that anyone who is drawn to that which is being offered by the Philosophers of Nature is on the Path of Return.

2. At this point in time there is very little offered to those in the West that are on the Path of Return which is Western in origin and which is freely and publically available. A certain amount of comparable material is offered by Societies which are not open to the public. However, what such organizations provide often comes with certain obligations attached and personal freedom is sacrificed. Further, to our knowledge there is no other public organization which offers information of this quality on laboratory Alchemy and such significant insights into the connections between Alchemy and Qabala and how Initiation may be realized through their study.

3. There are approximately 1,200 members in LPN France and Philosophers of Nature. These members, for the most part, make available to the combined membership that which they have learned through study and personal experience on the Path of Return. This means that each individual member has considerable resources to draw upon, beyond what each as an individual is able to discover through his or her own personal efforts.

A final thought. We are still in the process of rediscovering and reclaiming the contents of that transformatory World View which was known and practised by certain of the Ancient ones. We will remain unable to replicate what they accomplished until we also possess that World View as our own.\* It will require years of additional Ora & Labora before we attain a clear enough picture to enable us to experience that which we aspire to. However, if we work as a cooperative, for the good of all concerned, the probability of our eventual success is much increased and it is certain that progress on the Path of each of us will be greatly benefitted.

\* A World View can be thought of as the filter/transparency through which each individual interfaces with the Universe (both internally and externally). As such the World View which each of us holds is the primary determinant of our individual life experience.

# NOTICE: DR. NAWROCKI'S WORKSHOP NOT A PHILOSOPHERS OF NATURE SPONSORED EVENT

From time to time we receive requests from teachers of Alchemy and related subjects for our mailing list. In most cases they wish to reach people associated with Philosophers of Nature in order to invite them to attend seminars or to sell products. It is our policy to not release our mailing list to anyone so we decline. However, in an effort to assist fellow seekers we will often offer to be of assistance by:

1. Suggesting that they place an advertisement in the Stone which goes out to members and subscribers.
2. Offer to do a mailing for them using our mailing list. We charge for time and materials and can usually get the mailing out in a week or so.

In March, member Dan Bielin requested the use of our mailing list so he could send announcements of a workshop being held by Dr. Werner Nawrocki from Frankfurt, Germany in Santa Cruz, California.. As usual we declined but offered to do a mailing for him in an effort to be of assistance. He was to send us the literature and envelopes and we would send the material out to those on our mailing list for a modest fee. Dan sent us the literature and envelopes the next week. Unfortunately the envelopes he sent did not have his return address on them and our office staff being ever helpful and anxious to get the job done on schedule used Philosophers of Nature envelopes instead. Not a good idea. We subsequently got a number of calls and letters inquiring about the event because the recipient of the literature noticed the flyer came in a Philosophers of Nature envelope and not surprisingly believed it to be a Philosophers of Nature sponsored event.

Therefore, let it be known to all readers of this newsletter that Philosophers of Nature did not sponsor Dr. Nawrocki's workshop. We think very highly of Dr. Nawrocki and acknowledge his fine reputation as a teacher of Alchemy and related subjects in Europe but we goofed and wish to set the record straight as regards our involvement in the advertising for his seminar.

Attention Students of Qabala and the Western Mysteries...

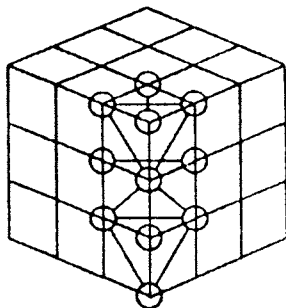

*"In the study of Qabalah there is no more important glyph than the Cube of Space..."*

Paul Foster Case

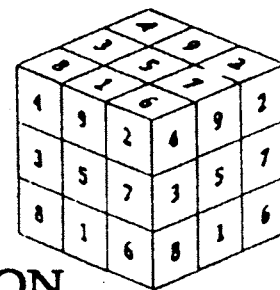

## THE CUBE OF SPACE: THE CONTAINER OF CREATION

a book by Kevin Townley

Topics include:

- \* Generation of the Cube of Space through geometry.
- \* The Magic Square of Saturn.
- \* Relationship of the Cube to the Tree of Life.

- \* Placement of the Tarot (Minor Arcana) on the points of the Cube.
- \* The Cube's relationship to the Macro and Microcosm.
- \* The Cube of Space in the Four Worlds.

To order send \$45.00 plus \$3.00 for postage to  
Archive Press, Box 11218, Boulder, Colorado 80301.

**"As Above, So Below"**

**When you understand the process of Divine Creation on the macrocosmic level, you can apply those same principles on a personal (microcosmic) level!**

# "The Alchemists"

## a book by F. Sherwood Taylor

Review and Comments by T. P. Scott

Whenever I come across a history of alchemy written by a scientist, I generally put it at the bottom of my reading list. However I recently rediscovered one that I think has especial merit that I'd like to write about. This is The Alchemists by F. Sherwood Taylor.

It was originally published in 1951 and, although reprinted a number of times, remains somewhat hard to find. In 1992, Barnes and Noble reprinted it, which would normally be cause for exultation. Unfortunately, due to what appears to be gross negligence on the part of the publisher, the new edition is sadly deficient.

The Alchemists was originally published in 1951 by Wm. Heinemann, Ltd. (London). It must have enjoyed some success, as it was reprinted by that publisher in 1953 and 1958. In 1976 an edition was printed by Granada Publishing, New York. These are all scarce. Thus the time was certainly ripe for a reprint, and I was delighted to find a copy in the "bargain new books" section of a Barnes and Noble bookstore. I immediately bought it without even looking inside. Unfortunately, as I sat down to read it, my enjoyment soon turned into incredulous dismay when I realized that *practically all the illustrations and plates were omitted* (except for Figures 1-8). This is truly an outrage when you realize that the original book was quite extensively illustrated: it had a frontispiece, at least 27 figures and 14 plates!

For instance, on p. 119, Taylor writes: "The five sets of four pictures comprising plates 9, 10, 11, 12, and 13 taken from the *Philosophia Reformata* of John Daniel Mylius (1622) are an example. It may be worth giving such notes upon them as an uninitiated author can furnish..." which he then supplies. Clearly, without the referenced illustrations, the following text is almost useless. Fortunately, these plates are available in other works, although none of them very easy to acquire.

The most charitable thing I can say is that the person responsible for producing the reprint was incredibly careless. I can't believe anyone would consciously make the decision to reprint a book and leave out most of the illustrations.

That said, the book is still valuable, in my opinion, even if you have already read all those other histories of alchemy. Taylor ties alchemical theory firmly back to classical Greek philosophy and brings its history forward in an orderly, logical way.

I find both Taylor's attitude towards his subject, and the clarity and sensibility of his writing very refreshing. He develops his arguments well, and thinks and writes clearly without prejudices or condescension. Although it's clear he does not believe in the possibility of the transmutation of metals on the alchemist's terms, he still thinks the study of alchemy is important. Here is his preface, which admirably sets out the project he is essaying:

"The purpose of this book is to give a short and clear account of the alchemists, their ways of thought and their contribution to man's achievement. This is a peculiarly difficult task, firstly, because we do not know all that the alchemists believed and did, owing to their deliberate and avowed concealment of the parts of their work that they considered most important; secondly, because the alchemical habit of thought was very unlike that of the modern reader; and lastly, because so much of their work remains unstudied and a great deal of what is known about them is still a battleground for controversialists. Where so much is in doubt the scholarly course would be to present the arguments for the various views; but since this would result in a long work, unreadable except by scholars, I have been content to give the views I have reached as a result of some twenty years of study, views which I do not regard as more than approximations to the truth, an interim report as it were."

(This is a very modest statement, considering the many authors who would use "twenty years of study" to imply "I know all that is known or can be known about this subject.")

"If, as one of its historians has said, alchemy is the history of an error, why study it at all? There are, I think, three reasons for doing so.

"In the first place, the hopeless pursuit of the practical transmutation of metals was responsible for almost the whole of the development of chemical technique before the middle of the seventeenth century, and further led to the discovery of many important materials...Secondly, we recognize today that science is not only a picture of the world here and now, but a human activity which can only be understood as a growing organism. Those who would understand the growth of chemistry must needs trace to their roots not only the fundamental chemical ideas, but the character and society of chemists; and it is in the alchemical laboratories that these took their origin."

Historians of science will always say this, and technicians will always ignore it.

"Thirdly, the historian of today has a wider outlook than his predecessors and is not exclusively concerned with the political and economic aspects of past ages. The history of ideas is beginning to seem no less important than these, and the history of man's ideas concerning his relation to matter will, I am confident, appear to the historian of the future as a significant factor determining the history of the last five hundred years. The history of the attitude of man to matter in the years before 1600 has hardly been attempted, and it is hoped that this book will be a small contribution thereto" [pp. 9-10]

With this I heartily concur. Although the concept of "the evolution of ideas" has become more common in the last few decades, in the 1950's the clockwork view of the universe and all its parts was still dominant and Taylor's view would probably be seen as radical verging on the heretical.

I'd like to present some extensive quotes here from Taylor's recapitulation:

"Alchemy...was essentially religious. Its philosophy aimed at the unification of all nature in a single scheme, the author of which was avowed to be God. The attitude of the alchemist towards nature was a religious one. His view was hierarchical; he arranged the substances of which the world was composed in grades of worthiness. The angels were worthier than man; man, than the animals; animals, than plants; plants, than the elements; the fifth element was worthier than the others; fire, than air; air, than water; water, than earth; gold, than the other metals. The changes in nature were thought of as exaltations or degradations in that scale. The alchemist had a direct intuitive appreciation of nature, he reacted affectively to bodies and loved them according to their worthiness, that is their resemblance to the spiritual, the noblest part of nature. This view was made the easier by the alchemist's view of all things as interpenetrated and animated by a living spirit. The world for him was alive and, as Aristotle saw it before him, struggling towards the perfection of God's idea of it.

"[Modern] Science knows simply nothing of all these ideas. Not one thing is worthier than another to the eye of the scientist. If he loves nature, that love is not allowed to enter his books. Matter for him is non-living, and the life he studies in biology is not that life we experience and desire to have more abundantly.

"So much then, for the profound differences between alchemy and chemistry; but despite all these the contribution of the alchemists to chemistry is by no means to be ignored. It seems fairly certain that the alchemists invented, and quite certain that they transmitted, the fundamentals of laboratory technique. They taught us how to handle chemicals, how to distill, sublime, filter, and crystallize; they distinguished and named such important reagents as the mineral acids and alcohol. In this respect alchemy is continuous with modern science.

"Furthermore, the alchemists founded their work on the idea of natural law..."

This is a very important point. To the alchemist, the process sought was simply an extension of logical analysis. Put another way, there was no reason it ought to be impossible from the data available to him.

"...They did not seek to obtain arbitrary or miraculous interventions in the order of nature, as did the type of magician, too common in the Middle Ages, who sought to change the course of nature by the invocation of demons. The alchemist believed that there was a natural process by which gold had been and was being generated in the rocks, and he sought to bring about that process in the laboratory. His theory of the generation of gold was incorrect, but in seeking to do what nature does, he was carrying out what has become a respectable and standard procedure of science. Thus alchemy, in so far as it was a laboratory research based on supposed laws of nature, was on the line of progress that has led to modern science..."

This is, of course, all very interesting from an academic point of view. But what value is it besides that?

"...Has science today anything to learn from alchemy? Nothing, I believe; for science has been refined until it is an

almost perfect instrument for its purpose. No importation of the philosophical or religious into science is possible. But has the scientist anything to learn from the alchemist and his medieval contemporaries? Perhaps. He can learn that there are aspects of nature that do not appear in the scientific journals; that our impressions of her have in them something of man as well as of matter. He can consider her under the aspect of value as well as of disposition in space and time; he can reflect upon the mystery of the existence of the world and of his relation to it.

"We shall not return to the alchemists, ["we" referring to orthodox science, I suppose] but doubtless the pendulum, which has swung from the spiritual view of things to the material one, will swing back, and succeeding generations will see the medieval and alchemical concept of nature as a poor foreshadowing of the natural philosophy which they will have attained." [pp. 180-2]

...or perhaps future generations will see the current mechanistic, materialistic view of nature that way.

Taylor here veers dangerously close to the mystical for a scientist, but I imagine the possibility of even Frater Albertus nodding with approval at some of these sentiments.

I'd like to also note Taylor's comments on "Recommendations for Further Reading."

"It is not easy to pursue alchemical studies further than the account given in this book without plunging into rather deep water..."

Anyone interested in the subject can certainly agree with this. In fact, except for Junius' Plant Alchemy and Frater Albertus' The Alchemist's Handbook, even the most diligent searcher will be hard put to find any practical or useful guidance whatsoever in even making a start in laboratory work.

"...The list of books here suggested is far from exhaustive, but has the merit of consisting only of reliable works. Many of the older accounts of alchemy are uncritical and lacking in historical sense, and many of the modern ones are mere alchemical tittle-tattle. Unfortunately most of the books here recommended are expensive and rare, and it is very hard to study this subject without either a long purse or access to one of the great libraries." [p. 183]

One of the works he lists is Ashmole's *Theatrum chemicum Britannicum*, about which he comments "This is a collection of English alchemical poetry, valuable in every sense, and should be reprinted." Fortunately, someone agreed and this was reprinted in 1967 by the Johnson Reprint company.

In summary, I think this book is one of the most thoughtful and cogent of the numerous histories of alchemy and would recommend it highly. Now that it is available in a cheap edition, it is almost a shame to pass up. Unfortunately, some of the illustrations are fairly important and this production is an insult to anyone who cares about the integrity of books, and a disgrace that Barnes & Noble released the book in this form.



## Jean Dubuis Lectures in Illinois and California

by Russ House; additional material by Art Kompolt

It was a pleasure to spend time with Jean, Marc-Gerald, Patrice, Etienne and Benedicte when they visited Winfield and California. On February 27, 1994, Jean spoke to an audience of just of 30 people in Glen Ellyn, Illinois. The topic was "Alchemy: An Initiatic Path". Jean offered many insights into his understanding of the 'Becoming of Man' to an audience composed of members and non-members. For many people, it was the first exposure to ideas along these lines.

Steve Freier, who hosts a metaphysical talk show on local radio attended the lecture, and interviewed Jean Dubuis for an hour-long show the following night. The interview was also video taped. After the most recent discussion group meeting, a number of members watched the video of the interview to determine if it would be of interest to members and the public. It was generally thought to be a good introduction to the philosophy of the organization.

Personally, I found the lecture very informative, thanks to Steve's probing questions. As a result, Jean spoke on his views of revelations to come to society in coming years regarding freedom and initiation, as well as his views on organized religion, concept of God, reasons for forming the LPN, benefits of alchemical and qabalistic paths to humanity, and other topics of real interest. The video reveals at least one 'ham'. We will make an announcement in the April issue regarding availability and cost.

On Tuesday, I left with our five visitors for the warmer climate of central California. We visited San Jose, San Francisco, Monterey, Carmel, Napa and Sonoma. On Saturday, the seminar consisted of a private morning session with Mr. Dubuis speaking on the Acetate Path. About 20 people were present for the morning session which was limited to members of the San Jose Alchemy Workshop and guests that had previous laboratory practice.

The afternoon seminar was open to the public and Jean spoke on Alchemy and the Qabalah. The seminar showed how the Qabalistic Tree of Life could be used to facilitate the Alchemical work.

Over 60 people attended the afternoon seminar which was enthusiastically received by those attending. A question and answer period was held at the end of the lecture which was very popular in that many people wanted to continue asking Jean additional questions. For Jean, a life-member of the English Grand Lodge of AMORC, it was a memorable occasion. The event was sponsored by the San Jose Alchemy Workshop which regularly meets at the AMORC laboratory there. We are especially grateful for the efforts of Art Kompolt, Janet Phares, "Mac" McCorvey, Joanne Weaver and David Alexander. Their enthusiasm, hard work, endurance and hospitality made the event a genuine success.



# The Research Group: How It Formed in the US

by Russ House

In France, there are a number of members who conducted coordinated research along the lines of Alchemy, Qabala and Esotericism, the results of which are integrated into the teachings of the organization, and shared with members in seminars. The research is costly in terms of financial expense, and the limited number of researchers also hampers progress. It was requested that our organization take the steps which would lead to our becoming peers of the organization in France, thereby sharing the expense and responsibility for contributing to the body of knowledge.

During the various seminars, Jean Dubuis and others spoke of the research group which exists in France. The amount of research required to confirm or deny various theoretical points, and to develop improved techniques is far too demanding on any one or two people. Therefore, various projects requiring attention are communicated, and members then take responsibility for conducting experiments which will assist in furthering the knowledge of the group at large. Even with the workload spread out to a number of qualified members, the financial considerations remain. Since the organization in France has approximately 1000 members, there is a limited budget set aside to fund such research.

Jean Dubuis expressed a desire for me to lead the formation of a similar group in this country, which would work in concert with the organization in France. The purpose is to begin the process of helping the America organization to make a transition from a passive to an active phase of activity. Until this time, our organization has been in a receptive phase, receiving theoretical, philosophical and technical information which was embodied in the lessons, publications and seminars by the French LPN. It is necessary to have such a period of receptivity, in order to understand the philosophical tents of the organization. It is during this time when those who have affiliated with the association must determine whether the ultimate direction of the organization is in agreement with their inner master. To me this does not so much mean an agreement with the more mundane aspects of the organization, as it does with the underlying philosophy, and intent.

## THE PURPOSE OF THE WORK

Since the purpose of the Work is not to accumulate facts and techniques, but rather to activate the God-seed on the Path of Return, there is a natural exuberance and inner response which is stimulated when the appropriate conditions are brought together. For those who find the Work of the Philosophers of Nature to be in accord with their growth, it is quite natural to desire to become increasingly active and to become more generous in their hearts. To such a one as this, research is one means to share the benefits of personal work with many who seek the Path of Return through Alchemical, Qabalistic and Esoteric work.

I have heard from a number of researchers, particularly those with a decade or more of practical work along these lines, that the French members of LPN do not seem interested in learning from them - that there does not seem to be a respect for what they have learned. Leaders of LPN France have told me that the US has a wealth of resources which eclipse those of Europe. There is a desire to create a fraternal cooperation between independent and equal associations of individuals, here and in other countries. This relationship which is just now developing, will result, in time, in mutual exchanges of tremendous importance. Further, there are numerous reasons why there is a sense of urgency in transmitting rapidly to the US that which has been developed in Europe, and as a result, those who travel here concentrate almost exclusively this task.



# Philosophers Study Group Forms in Chicago Metro Area

*by Russ House*

On January 29, 1994, the Chicago area was blasted by extreme weather conditions. Air and ground travel were, at best, hazardous. The media cautioned people to stay indoors. In spite of the difficulties, Jim Roederer arrived from Kentucky, and Darrell Greenwood braved the roads connecting us to another suburb. What could be so important? It was Darrell's birthday, but we learned of this fact later. The crucial event was the birthday of the Philosophers of Nature Study Group. Sue and I had notified all members of the organization in Illinois and surrounding states of this organizational meeting, and the initial responses had been quite favorable. The winter had cast its icy spell on our roads, so there were reluctant cancellations all during the day.

Undaunted, the four of us worked from 2 until 5 that afternoon, and when we were done, we were satisfied that something wonderful had been accomplished. A document detailing eleven guidelines for the organization had been polished and was ready for presentation to the membership at the next organizational meeting scheduled for March 26. Our intent had been to form an association which would be consistent with our understanding of the philosophies which we are studying the Philosophers of Nature. We wanted to create the form which would absolutely respect the freedom of individuals, which would avoid the creation of a hierarchy, and which would not support 'masters, gurus, or priests'. We also wished to encourage freedom from dogma, and enslavement by erroneous traditions. The association which we wanted to support would need to encourage self discovery, and active participation. Give these things in common, we had set down guidelines which we hoped would make the intent quite clear. It remained to see if the membership at large would agree with our own ideas, to the minutes of the meeting were mailed to area members, with an announcement of the second organizational meeting. At that time, these guidelines would be discussed and modified as required, and then voted upon point by point.

Sixteen members attended the second meeting, with all of the members from the first meeting returning. Two members attended from Wisconsin, two from Indiana, one from Kentucky, and seven from Illinois. The minutes of the first meeting were read to the group, and then began the lengthy process of discussing each point and making necessary changes before approval. When we were finished, one of the original guidelines had been removed by unanimous vote, and two other points had been improved upon by additions or slight changes. During the process we had touched upon many points of business, and had begun to form a genuine association. I am truly happy that members can meet together as equals, as brothers and sisters who are free to speak of their ideas and their experiences, and who are able to use such an association as a way to finding their personal path.

The purpose of the group is to create a forum to permit members and interested non-members to gather periodically to discuss the content of the published courses and articles of the Philosophers of Nature, as well as the content of seminars. Members who have research projects will also present their progress and findings.

## Research & Seminars Group Activities

*by Russ House*

The Philosophers of Nature is an association in the midst of transformation from one phase of activity to another. The purpose of this article is to offer some background on what has taken place, the key events and changes, so that members are aware of new opportunities and challenges.

### THE BEGINNING

In 1985, Bill Van Doren and others first contacted Les Philosophes de la Nature (LPN), a French esoteric organization founded by Jean Dubuis some years before. Some months later it was decided to begin translation of the French language lessons into English. Thus began a translation project of immense importance, which would require significant efforts and funds for the next several years. There was no need for a formal organization, as most of the work was done by Bill, Kevin Townley, and translator Brigitte Donvez.

### THE FOCUS OF THE ORIGIN

The lessons were first offered to the public on a subscription basis in mid-1988. From that time until the Fall of 1992, the primary focus of LPN-USA was to provide the translated teachings of LPN France to English-speaking subscribers. Some subscribers contributed funds to defray office costs and to fund the ongoing translations, or assisted in



other ways from time to time, but there were never more than a few individuals working on the project simultaneously. THE STONE, the newsletter of the organization, was first published in the Fall of 1990, edited by volunteered Ken Miller. For some time, Karin DiJiacomo served as office manager, a position now served by Karen High. In 1994, the initial translation project was, for all practical purposes, completed. The initial phase had spanned approximately seven years. The second phase was to bring many challenges along with the benefits.

## A PHASE SHIFT

In May, 1992, I was invited to attend a bilingual seminar organized by Gilbert Arnold and others in Canada. Mr. Jean Dubuis, the Founding President of LPN-France was to be the primary lecturer. This seminar was to make a tremendous impact upon me. Since that time, I have had to reexamine much of my former thinking, with resulting changes in my personal priorities and philosophy. This seminar also initiated the second phase of activity of the LPN-USA.

## THE FIRST NORTH AMERICAN SEMINAR FOR LPN FRANCE

When I arrived at the Canadian seminar, it was already in progress, due to various transportation delays. At the first break I whispered to one of my friends. "Have I missed much?". The response was "Not much", or "Nothing you don't already know", or something along those lines. This was NOT a favorable omen, as I could not afford to travel to the seminar in the first place. I decided to hope for the best. As I look back at my notes from that seminar, it is obvious that I was soon finding a lot that I did not already know. There was a great amount of technical information, related to the making of plat stones and the "Flamel Path" of animated mercury. As impressive as some of the technical details may have been, there are tens of thousands of pages of technical details in my library. Over time, I had spent numerous weeks in seminars on Alchemy with some good teachers, and a good decade of regular seminars on Esotericism, Hermetic ideas and Qabala in initiatic organization.

## PHYSICS AND QABALA

On those three days, Jean continually used two charts in his lectures on Alchemy - the Qabbalistic Tree of Life, and Mendeleev's Periodic Table of the Elements. Never before had I been exposed to such concise relationships between Qabala and Alchemy! This may have been sufficient on its own to cause me to start explorations in new directions, but there was more.

There were various references some direct, and others more subtle, to a coherent body of theory and to a code of ethics which I had encountered in ancient German writings. The code of ethics was given as a group of 7 rules drawn from the FAMA, which were different in several respects from the familiar versions of this law. It was apparent that these guidelines were treated with great respect by Jean and the other representatives of LPN France who participated in the seminar. For the first time, I had seen the people who had developed the written lessons, had experienced their generosity, and had been challenged to by core.

## AN INVITATION TO TEA

On the second day, I approached the group from France, and invited them to conduct a similar event at my home the following Spring. I felt that people in the US must have the opportunity to hear the ideas of LPN France. They immediately agreed to come, and indicated that they could come in September. After some frantic planning with Sue, via phone, and further discussions with the French, we agreed to have a seminar on October 1 - 4, 1992. Thus began a five month planning process which involved a number of members in Europe, the officers of LPN-USA, Bill Van Doren and Kevin Townely, Karin, the secretary of LPN-USA, Sue and myself. Somehow, it all came together.

## I THINK I MIGHT KNOW YOU

The seminar was the first time that many of those coming had met face to face, even though many had been in correspondence for years on esoteric topics. Others saw friends that they had not seen in more that twenty years. All of us were pleased, I think, with the opportunity to be together and to devote several days to the subjects closest to our hearts. There had been precious few opportunities for such gatherings in recent years. For all but a few members, this seminar was to be their first introduction to the French LPN. Some members seemed to be as deeply touched by their experiences as I had been in Canada. A total of seven members of the French LPN participated in the seminar.

## ENCORE

During the following April, Jean Dubuis returned for a two-day seminar in our home, and during the days before the event, we began planning for a five day seminar in the following September. This latter event attracted over 100 people,

and was conducted by 14 members of the French LPN at a rented Girl Scout camp west of Chicago. This event was followed by two brief lectures by Jean Dubuis, in Glen Ellyn, Illinois, and in San Jose, California. organization of all but the latter event had been coordinated by Sue and myself, with Sue taking care of all detailed planning, committees and registration. Bill, Kevin and the office manager supported many advertising and promotion tasks, and I provided the equipment as required by the instructors, and took care of other technical matters. This was a lot of work for our team, but we were excited to offer something new to subscribers.

### A ROSE BY ANY OTHER NAME

In March, 1993, the organization was incorporated as The Philosophers of Nature. During the April, 1993 seminar, further changes were initiated. Bill Van Doren and Kevin Townley asked if I would join them on the board of The Philosopher of Nature as Secretary. Jean Dubuis requested that I act as coordinator of seminars in the US, and act as liaison to LPN France, with responsibility for research projects of The Philosophers of Nature. There is a separate article on this topic in the newsletter.

### EXPANSION PLANNING

Jean asked that our organization continue to expand its scope of activities to serve a greater number of people. A number of revelations were shared related to the future of the organization in France, which involved concerns related to the political stability of Europe, as well as challenges internal to the organization itself. There was sense of urgency related to our taking steps to become stronger as an organization, was wee as tot the transmission of esoteric information while the opportunity to do so existed. Perhaps these comments will be of benefit to members who have expressed concerns about the overwhelming amount of information that has been give at some seminars. Once the information has been transmitted and is received, it can be more carefully organized and its presentation refined over time, so that it can be assimilated at a more leisurely pace. Then it will be possible to make an assessment of the real value of the teachings given.

### LIBERTY, EQUALITY AND FRATERNITY

During the seminar in September 1993, there were many business meetings taking place, often several lengthy meetings during the day and well into the night. We agreed to draft a fraternal agreement between the independent organizations in France and the US. There were a number of errors, oversights and misjudgments which are, perhaps, unavoidable when organizations existing in different cultures with different values and laws attempt to come together for mutual benefit. I think that I began to understand some of the problems inherent in international diplomacy for the first time in my life. Despite numerous difficulties, an agreement was drafted, and signed by officers of both organizations during a special session at the seminar.

### ACCEPTING RESPONSIBILITY

These cost of the seminars and the travel to continue the development of mutually beneficial relations have been quite expensive for LPN France. In every case, the events have operated at a net loss, and LPN France has paid for the remaining expenses. The Philosophers of Nature in the US has reinvested all income in translations to date, and has had no revenues to help in supporting seminars. The leadership of the French LPN has been willing to spend significant sums in order to assist in the growth of the organization here, and they have done so as a gesture of fraternal generosity. Their interest is not to make money, but if there were continual expenditures of this sort in the US, then it would not be possible for them to assist in developing the organization in other countries.

### GAINING GROUND

Currently, a number of seminars have been given at various locations in the US over the past few months by myself and others. The proceeds from these seminars will be used to create sufficient financial reserves to permit us to host additional seminars with some members of LPN France, in September, 1994. We are aware that there is a need to inform you well in advance of major seminars so that vacation schedules can be arranged, please refer to the seminar ad located in this issue.

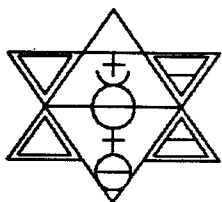

The Stone

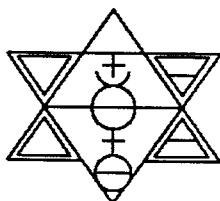

Page Forty-five

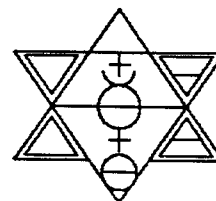

March/July 1994

*He's back!*  
(THE LAST GREAT ALCHEMIST IN PRINT)

# ALCHEMICAL WORKS: Eirenæus Philalethes Compiled

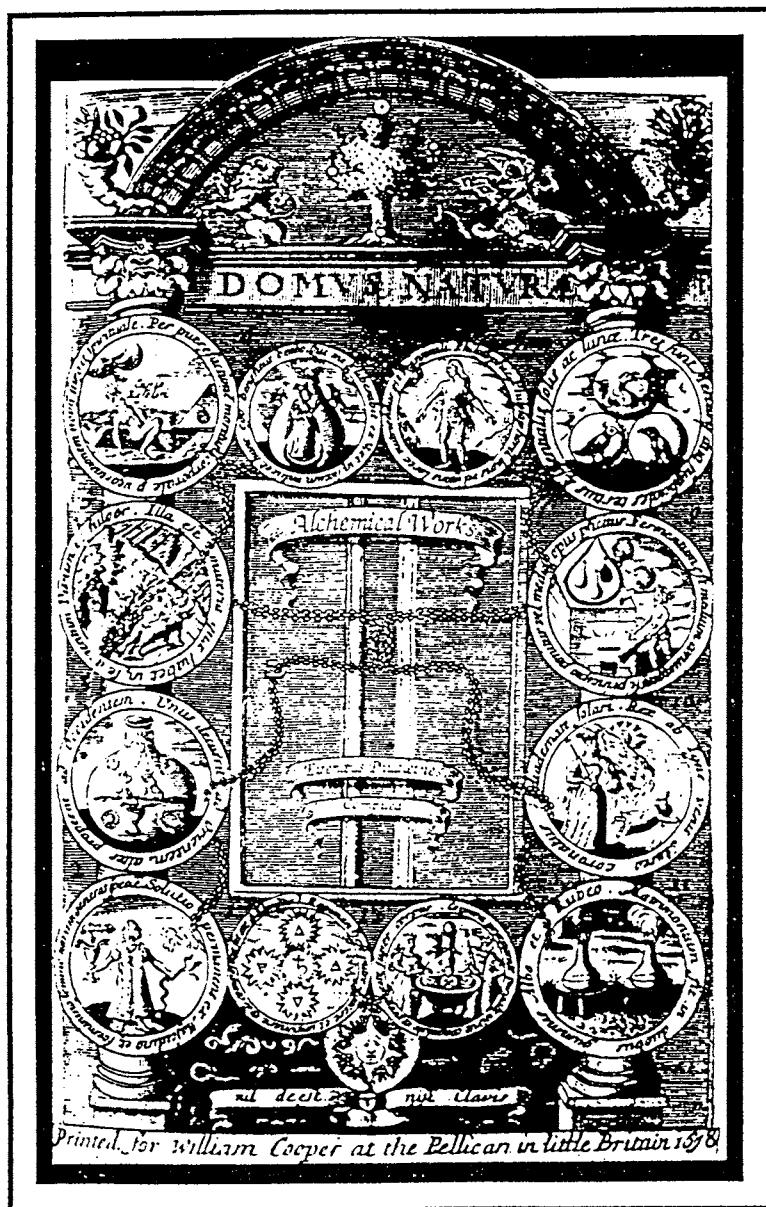

hard cover 592 pages indexed a.f.p. ISBN 0-9640067-0-7 \$60.00

\$65.00 U.S. Postage paid to:

LPN-USA

Box 11218

Boulder, CO. 80301

The Stone

Page Forty-six

March/July 1994

Eirenæus Philalethes, mysterious alchemical adept of the seventeenth century has elicited intrigue, study, and controversy for historians, littérateurs, and scientists since these works were published beginning in the mid-1600's.

This volume is unique. It is the only to contain all Philalethes' works currently available in English, and it is indexed.

Original format has been carefully preserved throughout, offering readers access to complete, authentic, and legible text and content for their enjoyment and studies, without having to resort to the microfilm copies previously available to most readers as the only source for much of the text contained within.

The practice of alchemy has been perennial for all of written history, woven through one civilization and into the next, often tying them together. It is a science, a philosophy, a mystery, and a quest. The very word connotes a magic transcending our limited beliefs about the laws of nature. It was used as a tool of charlatans, who did much through their deceit to destroy the reputation of the science. Much more often it has been a field of study for great minds. C. J. Jung spent his last twenty years illustrating its value in framing the workings of the subconscious through alchemy's rich use of metaphor. Sir Isaac Newton poured over Philalethes' tracts, finally preparing what he thought to be *Philosophic Mercury* in 1675.

The essence of alchemical writings has been consistent through the centuries, while the details have been inscrutably and defiantly deceptive. Philalethes is called the last great alchemist in print. This collection presents a treasure map for many uses.

# Boiling Points of Water and Ethanol in a Vacuum

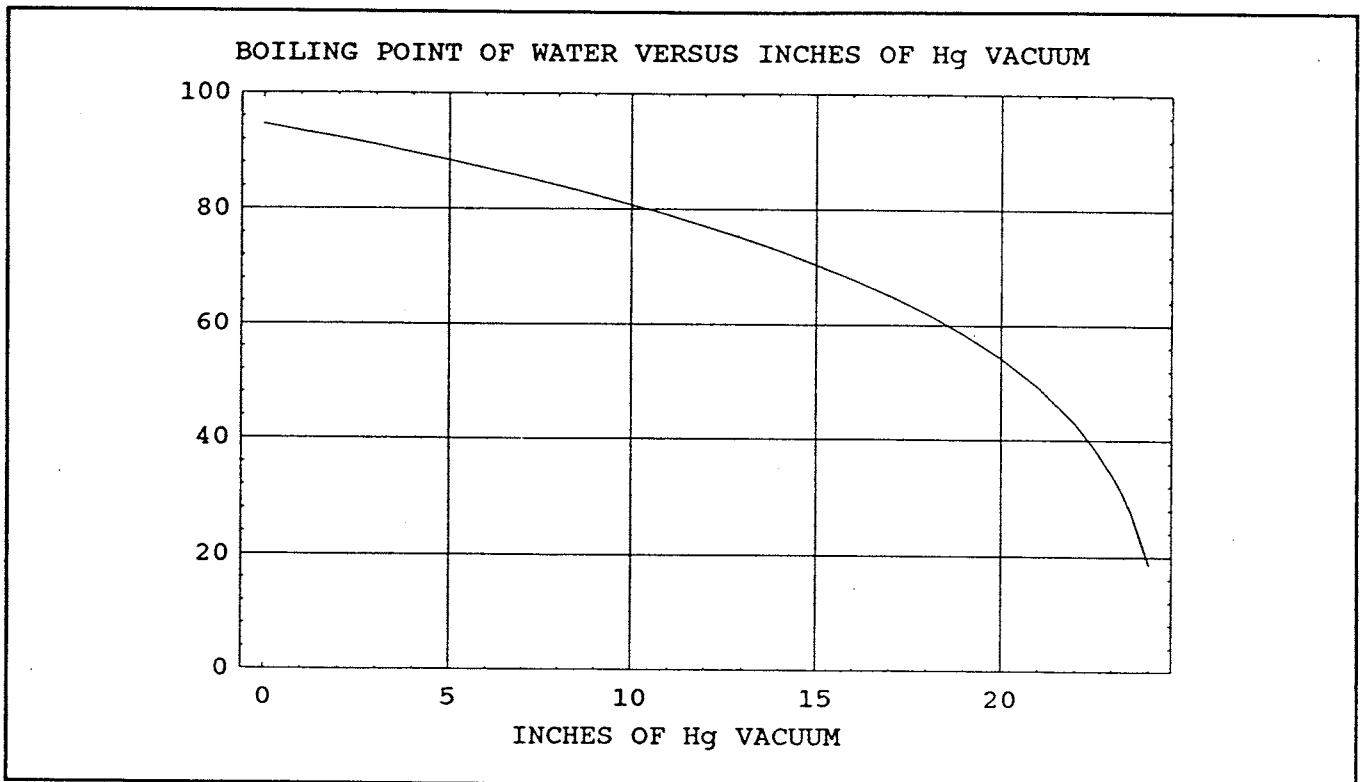
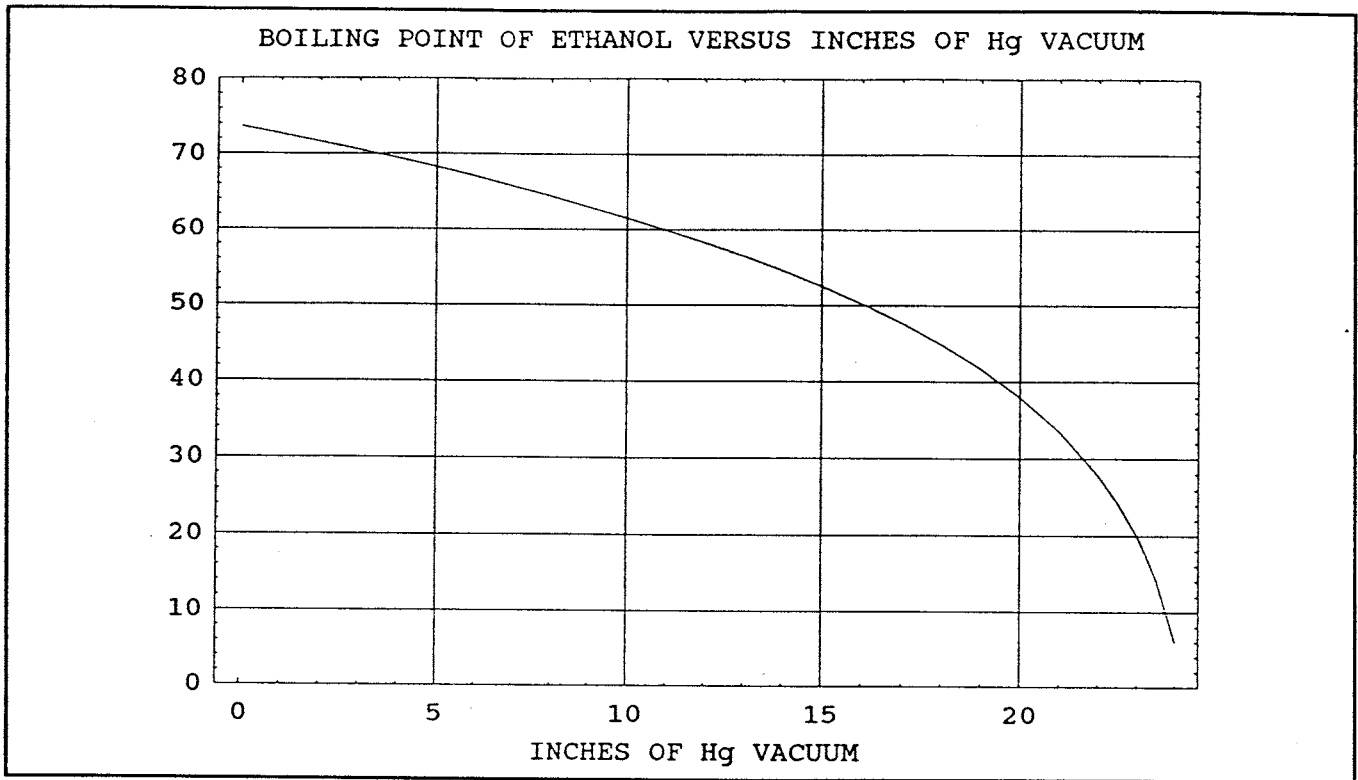



Russ House, Salome, Josette, and Jean Dubuis at Jupiter Oak

### **Rolling The Stone off the Press** by Ken Miller

Sorry for the long delay friends in getting this issue out to you; I hope you agree it was worth the wait. We have made some changes which I would like to mention. First, I've gotten rid of the voice mail number published in prior issues and now have a direct line you can call and possible even reach me, or at least my answering machine. You can also fax to the same number, usually. The number is (619) 528-4521. As always, long distance calls will be returned collect.

The Stone will now follow a regular publishing schedule, with issues being mailed in March, July, and November. We will strictly adhere to this schedule (unless the apocalypse...); and the issue you now hold in your hands is the double issue March/July 1994. Issue number 11 will reach your mailbox sometime in November.

We appreciate any and all contributions from members and others and ask that you note the following deadlines: Oct. 25 for the Nov. issue, Feb. 20 for the March issue, and June 25 for the July issue. Thank you for your kind attention and I look forward to reading your letters and hearing your comments.

## About The Stone



The Stone is published three times a year, in March, July, and November, primarily for the benefit of the membership of LPN-USA. We hope to get member's feedback regarding what they would like to see in it. Articles, photographs, drawings, letters, and comments from members or others are solicited for submission to the Editor for evaluation. Submissions and advertising should be sent to The Stone c/o Ken Miller, 405 West Washington Street, Suite 314, San Diego, CA. 92103-1996. Telephone (619) 528-4521. Deadline for submissions and advertising are as follows: October 25th for the November issue; February 20th for the March issue; June 25th for the July issue.

## Advertising



The Stone is now accepting advertising, both display and classified ads. Rates are as follows: Full page: \$100; Half page: \$55; Quarter page: \$30; Classified ads are \$0.05 per word. For more information call or write the Editor, Ken Miller, at 405 West Washington Street, Suite 314, San Diego, CA. 92103-1996. Telephone (619) 528-4521. Calls will be returned collect.

## Subscription to The Stone

The Stone is included in the cost of the lessons. Non-members may subscribe at the rate of \$20 per year (three issues). Subscription requests should be sent to the administrative headquarters: LPN-USA, P.O. Box 11218, Boulder, CO. 80301.

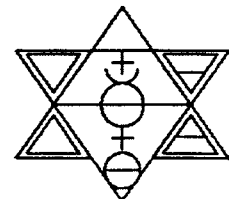

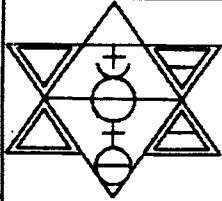

# The Stone

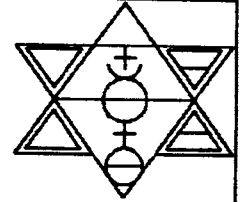

*Journal of The Philosophers of Nature*

Issue Number 11

November 1994

## Message from the New President

*by Kevin Townley*

Dear Friends, this past summer marked a very important milestone in the progress of LPN USA. Over the past few years we have been fortunate to have our French brothers and sisters come to the United States and offer their experience and knowledge to our group here in North America. This past September we were once again visited by the French with a slight difference. The members of The Philosophers of Nature - USA, did the major portion of presenting the material on Spagery, Alchemy and Qabalah.

This is a first for the American group. We have evolved from a correspondence school to a body of men and women who have come forth with their own experience and offerings to the general membership.

It is wonderful to behold the continual flow of energy that schools like the PON-USA demonstrate. All of this work and attention did not originate with the LPN, yet today it is, to my knowledge, the only organization that brings forth the initiatic path through laboratory spagery and alchemy.

The outer work of the PON is like a great Oak Tree that continually drops its acorns to the ground to have its seed continue the distribution of its intelligence. We have seen the Alchemical path brought to the United by Frater Albertus and for many years a strong gestating force in North America. The founder of LPN-France Jean Dubuis has brought a new cycle of learning and experiments. I would like to thank Jean, Patrice, and Michelle for their presentations at our 3rd annual seminar.

Special thanks need to be given; to Jack Glass and Russ House for their presentations to the newer members of the PON. Marcus Haubaenstricker, Kurt Kobylarz-Schmidt, and Art Kunkin also gave much of themselves as they shared their knowledge from their vast experience. I wish to thank all the individuals who offered themselves in service to the Philosophers of Nature during the past year and most especially during the fall seminar. A most special thanks is extended to Sue House for yet another herculean effort in pulling off the fall seminar. Thank you so much for your continued service.

At the end of the seminar, Bill Van Doren resigned as President of the Philosophers of Nature. Bill has served for many years in this position and was the major force behind the Philosophers of Nature coming to the United States. His vision of establishing a school dedicated to the path of return has been realized, and all members both old and new have the fruits of his many years of service to benefit from.

### In This Issue...

Message from the New President;

by Kevin Townley p. 1

The Moon: Rotation and Reflection;

by Lucile Gerbaut p. 2

Psychopathology & Occultism; by T. Scott p. 8

Oraculum; by The Sophist p. 13

Cleaning the Amalgam out of a Crucible,

by Nicholas & Pernelle p. 15

Creating Seven Planetary ENS;

by Nicholas & Pernelle p. 17

Advertisements

pgs. 19-22

PON Annual Report

p. 23

A Thought by Jean;

by Jean Dubuis p. 24

have the fruits of his many years of service to benefit from.

I want to offer my sincere and heart felt thanks and gratitude to Bill for his leadership and his quiet and relentless way of getting things done. It is seldom that one enters into service and has such impact on the lives of so many and remains selfless in the process.

During the board meeting Kevin Townley was elected President, Russ House was elected as the new Vice President, and Kenneth Miller was elected Secretary.

Please let any of the officers know if there is anything that we can do to improve our organization. We stand ready to bring classes and seminars to places around the United States and Canada should there be sufficient interest on the part of the members.

As the winter sets in and brings us to a more reflective space let us keep in mind the path of true service that comes from the heart, and continually leads us closer to the goal of oneness with the Invisible.

Ora Et Labora.

**The Stone, Issue Number Eleven, November 1994.** Published in March, July & November by The Philosophers of Nature. Editor: Ken Miller; Assisted by T. Branden. Copyright 1994.

# The Moon:

## Rotations and Reflections

by *Lucille Gerbaut*

Because of the disturbing influences of the Sun, and to a lesser extent of the Earth and other planets, the path of the Moon is one of the most complicated that can be observed among the heavenly bodies.

The study of lunar revolutions around the Earth has been used since very ancient times by astrologers, seamen, farmers, and today by space navigators who must take into account the Moon in their programming of cosmic rockets.

In another domain, in relation to the plant world, the knowledge of the path of our satellite and of the different synodic months provides us with precious indications that enable us to determine the more favorable periods of time for certain spagyric works. Some notions or reminders of astronomy will help us in our approach of the chart of coincidence (below) in a better way.

### THE LUNAR ORBIT

The Moon rotates around the Sun at an average distance of 384,000 km (239,000 miles) on an elliptic orbit of which the Earth is one of the two centers. When the Moon is closest to the Earth, we say it is in perigee; it is then 356,000 km (222,000 miles) away. When it is the farthest away, it is said to be in apogee and it is then 406,740 km (253,000 miles) away. The average rotation speed of the Moon is 1 km/s (0.6214 miles/second).

The line joining the apogee to the perigee is called the line of apsides.

The plane of the lunar orbit is inclined by 5° 8' 43" in reference to the plane of the earth orbit or ecliptic.

The ascending node or Dragon's Head (sign: ♁) is the point at which the lunar orbit intersects the ecliptic in the South-North direction for our hemisphere. The descending node or the Tail of the Dragon (sign: ♁) is the intersecting point for the North-South direction. The nodes are joined by the line of the nodes (see enclosed figure).

The time it takes for a lunar orbit to be completed is measured by the time interval between two consecutive passages by the hour circle of a same star, or sidereal revolution, the duration of which is 27 days, 7 hours, 42 min.

But owing to the various disturbances, other revolutions have been determined reflecting different times of passage in various points.

The two revolutions that are of special interest to us are the ones corresponding, on the one hand,



## The Moon, continued...

to the waxing and waning Moon, and on the other, to the ascending and descending Moon.

We should not confuse these two separate and independent phenomena. The Moon can be at once waxing and descending or waning and ascending.

### WAXING AND WANING OF THE MOON:

The phases of the Moon, the lunar month or lunation, corresponds to the lapse of time allowing the Sun, the Earth and the Moon to be in the same relative positions (generally two new moons); it is the synodic revolution (from synod= meeting or star conjunction), it occurs in 29 days, 12 hours, 44 min.

The origin of the lunar phases is due to the varying configuration of the three heavenly bodies: the Sun, the Earth and the Moon during a period slightly longer than the sidereal month, due to the revolution of the Earth which occurs in the same direction as the Moon's and that the Moon is trying to "catch up with".

The rotation of the Moon upon itself has an identical duration as that of its revolution around the Earth: that is why it always presents its same face to the Earth.

#### **Waxing Moon**

The Moon is waxing in the period elapsed between the New Moon NM, the First Quarter FQ and the Full Moon FM. To find out whether the moon is waxing, you can observe in the sky the luminous part forming a crescent that can be said to form a P with an imaginary stroke; P like Premier Quartier= first quarter .

#### **Waning Moon**

The moon is waning during the time elapsed between the Full Moon, the Last Quarter LQ and the New Moon, we can observe in the sky an imaginary crescent forming a D, prolonged by an imaginary stroke : Dernier quartier = Last quarter .

#### **Ascending and descending Moon**

For a time period of approximately 27 days 12 hours, called the periodical lunar revolution, the Moon "ascends" in the sky of the Northern hemisphere, and then "descends" (it is the reverse in the Southern hemisphere).

The Moon is ascending during the time when, every day, its apparent orbit is higher than that of the day before.

To know whether the Moon is ascending or descending, we can observe it by locating, as much

## The Moon, continued...

as possible, its position in the sky. The following day, approximately two hours later, the Moon goes through the same vertical line. If it passes higher in the sky, it means the Moon is ascending.

### THE MOON AND SPAGYRICS

In addition to other considerations (days of the week, equinoxes, planetary geniuses, solstices) there are periods of time more particularly favorable to certain works and which it is better to take into account. All distillations, particularly rectifications and the distillation of vinegar should be accomplished during an ascending moon.

On the contrary, operations on the salt should be performed during a descending moon.

The influence of the ascending moon is emphasized by the waxing moon and that of the descending moon by the waning moon.

It is advised not to perform any work during the 12 hours preceding and following the lunar nodes, particularly the descending node, and for the same length of time around the perigee.

Let us recall that several specific disturbances: the solar attraction, the retardation of the Earth, the retrogradation of the line of the nodes, the advance of the line of apsides, the variation of the speed of the Moon's rotation (accelerated around the perigee, delayed around the apogee) cause varying revolution times different from the SIDEREAL REVOLUTION. We have seen two examples. We can also indicate:

**THE DRAGONIC REVOLUTION:** (from the "Dragon" symbol of the lunar nodes), which is the time interval separating two passages at the ascending node; its duration is 27 days 5 hours 5 min.

**THE ANOMALISTIC REVOLUTION:** (from anomal=irregular) is the time interval between two passages of the Moon in perigee; it is 27 days 13 hours 18 min.

The phases of the Moon represent one of the best-known aspects of the Moon as observed from the Earth and one of the most impressive among celestial phenomena; it is not surprising that several religions have used them to establish their calendars or decide of important dates and that numerous mythologies have assigned divinities to the phases of the Moon.

### THE MOON AND THE CALENDAR

Although it generally follows the *solar* calendar, the Christian religion has determined the dates of certain mobile holidays according to a lunar calendar. The Christian Easter has been determined as the first Sunday following the Full Moon of Spring, by the council of Nicea in 325

## The Moon, continued...

A.D., but has been determined according to the data of an ecclesiastic "*comput*" which comprises elements indicated on certain editions of the calendar. For those who are curious about its meaning, here are some definitions.

### **The Dominical letter**

To each day of the year corresponds one of the seven letters of the alphabet from A to G, starting with A for the first of January, B for the second of January etc. The dominical letter of the year in question is the letter corresponding to Sundays. For 1991, the first of January having been a Tuesday, the dominical letter is an F. For leap years, there are two letters one for January and February, and another one for the other months.

**The Epact** is a number corresponding to the age of the Moon on the first of January, and to which you subtract one, calling 0 its age at the New Moon; it is comprised between 0 and 29.

**The Golden Number** corresponds to the position of a year in a metonic cycle of 19 years, which is the time after which the same lunar phases returns on the same calendar date. To obtain it, add 1 to one thousand and divide by 19; the rest of the division represents the Golden number of the year. A rest equal to 0 is said to be 19.

The Greek orthodox who do not follow the Gregorian calendar celebrate Eastern twelve days after the Christian Easter.

THE JEWISH CALENDAR is *solilunar* and has a 19-year cycle. The Hebrew people celebrated Easter for the first time when it left Egypt. This ceremony called *Peassah* (which gave *Paskha* in Greek and *Pascha* in latin and finally *Pascua* in popular latin) that is, the *passage* from slavery into freedom, was celebrated at Moses' order on the 14th day of the first month of Spring.

THE MOSLEM CALENDAR is a *lunar* calendar which comprises months of 29 or 30 days following exactly the path of the Moon. The years have been counted since the Hegira, date of Mohammed's departure from Mecca (July 16, 622 A.D.). The cycle of annual return is 33 years.

### MOON AND MYTHOLOGY

The mythologies of all countries endowed the Moon and its mysteries with a great significance. We are not going to go through all of them here but only to punctuate this chapter with one example.

In Greek mythology, divinities corresponding to the different functions have been attributed to the phases of the Moon. All texts agree to acknowledge a triple nature to HECATE, lunar and chthonian goddess, she who causes the souls to rise to the Moon; she was invoked at crossroads, particularly at the crossing of three paths. It seems therefore logical to attribute to her the Last

## The Moon, continued...

Quarter and the Path which leads from Malkuth to Yesod on the Tree of the Sephiroth. As the reascend from Yesod, can take place on three possible paths, it was tempting to link them to the other three phases: SELENE to the New Moon and to the Path that links Yesod to Hod, ARTEMIS to the First Quarter and to the Path leading Yesod to Tiphereth, and finally PHOEBE to the Full Moon and to the Path which leads from Yesod to Netzach. One of the possible interpretations has been illustrated in the enclosed figure.

### MOONLIGHT

The Moon does not radiate its own light. The light of the Moon is somewhat weak; as a matter of fact the lunar ground is dull, covered with several meters of dust which absorb 93% of the light it receives from the Sun; the remaining 7% that it sends back are modified.

The illumination of a solid body is all the more weak because the radiations it receives have an oblique impact. A lunar quarter, which has only half the surface of reflection, illuminates the Earth *twelve times less* than a Full Moon.

When the luminous crescent begins after the New Moon, or diminishes after the Full Moon, the phenomenon of *earthlight* causes part or all of the crescent to be perceptible to the eye; it is the *Earthshine*; the Earth is reflected upon the Moon and illuminates it.

The spectrum of the Moonlight is wealthier in the range of reds, poorer in the blue and violet range, than solar light, whereas, paradoxically, because of the imperfections of the human eye, the light reflected by the Moon appears to be blueish, and haloes nature with blue reflects.

The light reflected by the Moon is partially *polarized*. The vibrations issued from a natural light source are spread out uniformly around a ray. When a direction is favored the light is said to be *polarized*. Any reflecting surface sends the light back, the polarization rate of which varies according to the *quality of the surface and of the impact angle* of the light upon this surface.

The polarization of the lunar light varies during the synodic month; it is *highest around the first and last quarters and high* during the descending phase. This difference is due to the more important polarization of the light reflected by the seas which cover the most part of the crescent during the Last Quarter.

Perhaps to this polarization we can attribute the special effects of the Moonlight which was the origin of adages and numerous observations about the biology of plants, animals and men. (We say in French, when a person "reflects" on a privileged and specific subject, that he is "polarized" on it).

The discoloring action of lunar light is well known and it is recommended not to expose delicate

# The Moon, continued...

fabrics to that light. In certain countries, the light reflected by the Moon has the reputation of cicatrize and heal the wounds of plants as well as those of men.

Certain issues would gain to be studied in detail; perhaps they may inspire some of the readers.

A large part of the information contained in this article comes from the following documents:

- Atlas d'astronomie (Astronomy atlas), Ed. Perrin
- Influence de la Lune sur les Cultures (Influence of the Moon on crops) by Robert Frédérick, Ed. La Maison rustique.
- and particularly the booklet published by L'Association pour le Calendrier Lunaire (Association for the Lunar Calendar) 24, rue Paul Eluard, 39100 Dole, which groups very useful indications for those who are interested in the influence of the Moon and constellations on plant and animal life.

## Inclination of the lunar orbit in relation to the ecliptic

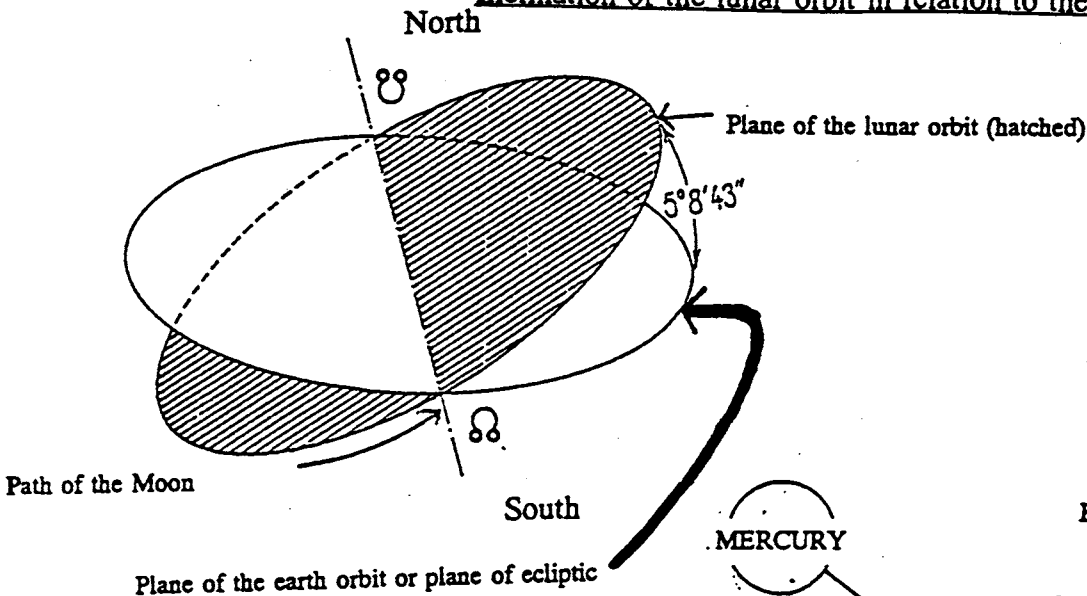

The Stone

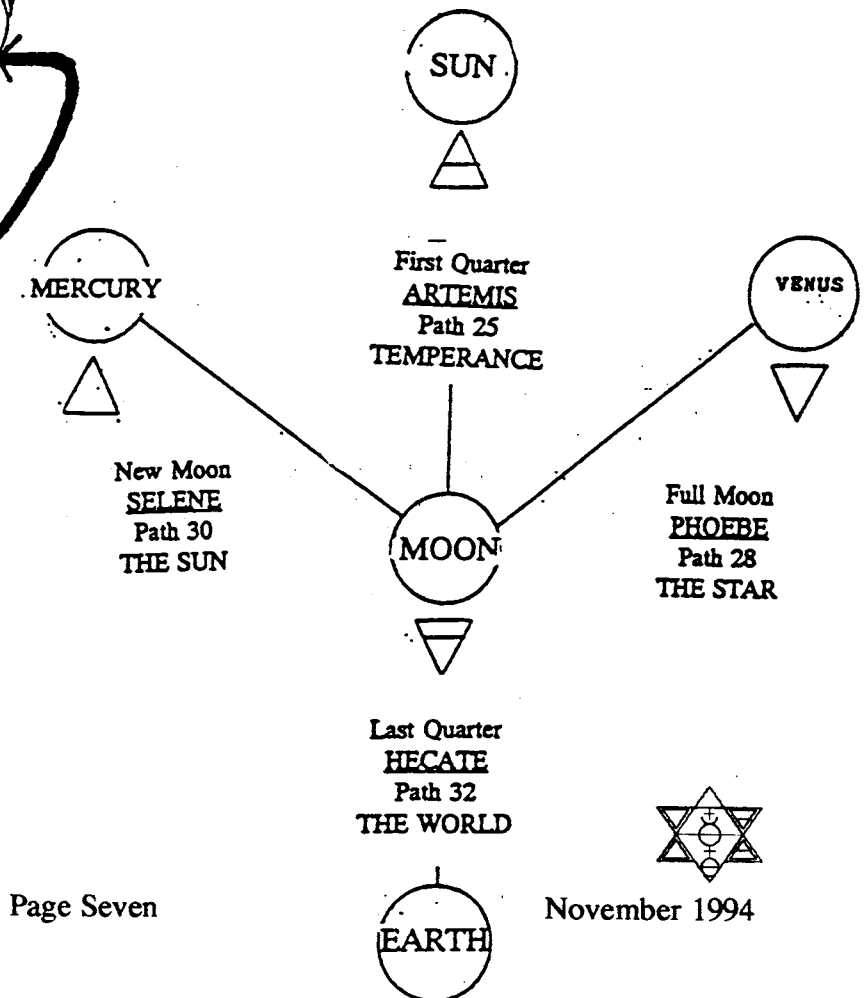

# Psychopathology and Occultism

by *Tim Scott*

## Introduction -----

The recent tragedy in Switzerland involving the "Order of the Solar Temple", following soon after that of the "Branch Davidians" in Texas points up once again that fanaticism knows no religious, historical, cultural or geographic limits. And as we approach the year 2000, the milleniarist lunatic fringe, always lurking in the background, will become more and more visible.

Of course, as normal, reasonable people with sensible beliefs, we don't need to fear this type of thing in our circles. But it may be interesting to examine this phenomenon a little more deeply.

There is abundant evidence and literature dealing with religious mania and psychoses, but in this article I'd like to discuss these matters with particular reference to students of occult or metaphysical arts.

Disclaimer: I am not a licensed psychiatrist, nor do I have a degree in psychology. But on the other hand, modern psychology is scarcely a science in the sense that physics, chemistry or astronomy are sciences.

## Statement of the "Problem" -----

Most of us have studied with or otherwise encountered occultists--students and teachers--who seemed to have severe personality problems. Granted, the difference between an interesting personality and madness can be small indeed. But I'm talking here about manifest megalomania, paranoia and truly bizarre behavior.

Although this type of judgment is certainly subjective, we can at least point to the difficulty different pagan, magical or occult schools have in harmonious cooperation. (To say the least). To an outsider, this seems singularly odd, as the avowed purpose of much of this occult study is to become \*more\* conscious, loving, and serene, not less. And yet there seems to be no less strife among occultists than there is among politicians, the religious or any other group. Possibly much more.

Although I do mention some specific personalities and groups in this article, it's not my intention to use it as a bludgeon against my enemies: these are just examples I either know better, or find more illustrative.

## Chicken or egg? -----

Another question is: did these problems pre-exist and were intensified by the peculiar energies involved in occult study, or has a perfectly normal person been driven crazy by it? As usual, there is no simple answer.

Many people with personality integration problems are drawn to occult and esoteric study. There are many reasons for this. Some do not function well in day-to-day life, and feel they need occultism to either escape from the ennui of mundane existence, or to otherwise empower themselves. Others may like the drama of ritual, the hierarchy of a group, the romance of the occult in general, or having secrets to which the common run of humanity are not privy. None of these things are evil, wrong or destructive in themselves, but escapism or anything carried to extremes can cause difficulties.

Consider our generic "normal" person who begins to study the occult. This person's psychic strength may be perfectly adequate to allow him to function on the mundane level. However, when dealing with intense mystical energies, well-repressed or unknown latent problems may suddenly become major issues. This is the reason for the "Mirror of the Soul" technique used in some occult schools.

## A proposed analysis of the problem -----

Back in the 1920's Dion Fortune recognized the very problem we're examining here and wrote:

"...we come to the point where lies the root of so much occult trouble, the point where psychism and psycho-pathology meet. The sensitiveness of the psychic can so easily turn into mental instability under adverse circumstances. For its

proper understanding a knowledge of psychology is necessary. ... "An adequate knowledge of the elements of both normal and abnormal psychology would do more than anything else towards preventing false concepts of occultism." (Fortune 1967, p. 141)

Although I don't share her characterization of psychology—at least, what is thought of as standard academic psychology—as that illuminating or useful. In 1984, Israel Regardie warned of these problems in these words:

"One of the great dangers inherent within the practice of Magic—and indeed of all the occult arts—is the development of an enormous egotism characterized by messianic feelings, infantile omnipotence and the utter destruction of any capacity of effective self-criticism. It appears that as the student becomes more adept in the skills of meditation, skrying or ceremonial work, he becomes more threatened by inflation of the ego. It appears slowly and insidiously, without apparent warning. Only those people who are closely related to or associated with the student become aware of the subtle metamorphosis that occurs. The student rarely is conscious of this unconscious transformation. Attempting to make him aware of this egotism is doomed to failure; it is like knocking on a stone wall. ... "It is a definite and ever present danger, and all students of occultism within or without occult orders must become conscious of this phenomenon. Otherwise they are doomed." (Regardie and Hyatt, 1984)

This is pretty strong talk. Is this problem one that is serious enough to warrant this kind of alarmism? As an example, let's look at the introduction of one of Aleister Crowley's works:

"This book is intentionally \*not\* the work of Frater Perdurabo. Experience has shown that his writing is too concentrated, too abstruse, too occult, for ordinary minds to apprehend... Before printing, the whole work was read by several persons of rather less than average intelligence, and any point not quite clear to even them has been elucidated. ... "May the whole Path now be plain to all!" (Crowley 1929)

I guess the extension of this is: if there is any point in the book that is still unclear to me, that means that I am of even \*less\* intelligence. Gee, thanks, O Great Mage.

After reading more than a little Crowley, one quickly realizes his strong predilection towards elitism and practical jokes. But as this particular book was supposedly intended for the magical tyro, it seems odd to open such a beginner's text with an egregious insult to the reader's intelligence.

### An occult interpretation (Case) -----

Paul Foster Case was a member of the Golden Dawn who left the group to form the B.O.T.A. (Builders of the Adytum) in the 1930s. In his writings on "spiritual alchemy" dating around 1960, he also cogently addresses the issue we're examining here. In the following passage, the "gross work" may be looked as the groundwork: getting one's diet and personal life on an even keel, examining oneself carefully for psychological problems, and attempting to straighten them out. The "subtle work," then, would be the actual advanced process of alchemy.

"It is because occult students are so often improperly or insufficiently instructed as to the necessity for the 'gross work' that so many cranks are to be found among them. They attempt the subtle work while their bodies are impure and weak. The inevitable consequence, even of such supposedly safe practices as meditation, and other exercises in Raja Yoga, is a distribution of poisons throughout the physical body. These poisons affect the brain, the nerves and the ductless glands. They are often responsible for serious alterations of personal character, ranging all the way from silly eccentricity through various phases of emotional instability, through profound neuroses, and even insanity.

"No error is more common than the notion that it is safe to undertake mental practice without physical preparation. We find this error in the writings of many teachers who ought to know better. Raja Yoga practice, meditation, visualization, and other forms of mental practice are just as certainly bodily activities as are walking or gymnastic exercise."

Unfortunately, Case is not very specific about what the correct preparation is. Two paragraphs later, he at least gives some hints:

"The purification of this [alchemical] water must be the first work of the alchemist. He must choose true foods, and regulate his habits of eating. He must control his sex-life, and see that kidney elimination is what it should be. He must learn, little by little, to rebuild his body..."



Innocuous, although somewhat vague advice. But this begs several questions, aside from the obvious ones of "what are true foods?" and "how do I ensure that my "kidney elimination" is "what it should be?"

In the first place, how do we pick a teacher? For instance, although what Case wrote seems reasonable (if sketchy), on what foundation is it based? His own personal experience? And how old was he when he died? From what disease?

Should we select a teacher because he or she has great charisma? Because he's old and healthy? And once we make this decision, how do we know whether the teacher really has anything to teach?

This is a complex topic and subject for a whole book. For instance, it is very easy to hop from teacher to teacher, or never commit to any teacher, since we're "still searching."

## **The Gurdjieff Work -----**

An excellent example of the dynamics of this issue is found in the groups and personalities centered around the early 20th century philosopher/mystic Georges I. Gurdjieff. When he was alive and directing his schools, they appeared to be powerful and vital; possibly because no one had a stronger personal presence than he.

Once he died however, in an amazingly short time his work groups splintered into numerous mutually hostile and sometimes bizarre factions. The irony here is that Gurdjieff's system was an attempt to raise humans above their petty bickerings, ego and power games, and neuroses. He insisted that lifelong, Herculean, continuous effort was required to rise above these games that most all humans seem to be addicted to. No sooner was he in his grave (sooner than that, by some accounts), and his most advanced, highly enlightened, students and associates began jockeying brutally for control of the organization. Reading the stories of the groups he led himself, then the stories of groups that were supposedly doing the "Work" within a few years of his death, points up in a very poignant fashion just how much was lost.

Personally, I've always thought there was something unique and powerful about Gurdjieff's philosophy, at least the way I understood it. Sometimes I have to face that perhaps the "Work" could never be a practical approach for normal humans, but only for those of the caliber of Gurdjieff himself.

## **The Battle over the O.T.O. -----**

One of the most colorful examples of the occult psychopathological syndrome is that of Marcello Motta. A passionate, if not positively rabid, Crowleyite, he believed himself to be the true successor of Karl Germer. (Germer was a faithful disciple of Crowley, and received the leadership of the O.T.O. and its copyrights on Crowley's death.) An indefatigable worker, Motta self-published a large amount of Crowley's material, some previously unpublished and some with new commentary. Some of this material is quite indispensable for serious Crowley students.

But even more than that, Motta's publications make fascinating reading. Although large portions of them contain valuable information for students of Crowley, the rest is an indescribable melange of raving, excoriation, self-aggrandizement, complaints about how unworthy all the people were he put his trust in, and general supercilious disdain of the common run of humanity. Each book contains fulminations against publishers he accuses of "pirating" Crowley's books, numerous expulsions of "purported" O.T.O. members, and general ranting in any direction that seems appropriate to him at the moment.

As a self-styled Master, Motta was of course quick to pass judgment on those he considered worthy of his contempt. One of the targets of his vituperation was Israel Regardie, who was at one time Crowley's secretary and published a number of Crowley's works.

"...Aleister Crowley should not be represented in print by liars or by thieves. Mr. Regardie, as his record proves, is both. Unhappily, too many Jews these days are both, in some context or another." (p. xi)

"...we deny Regardie moral character or spiritual understanding, but we do not deny him plain old everyday Yiddish cunning and worldliness." (p. xviii)

Neatly coupling his loathing of Regardie with a fine case of anti-Semitism. Regardie died, at the age of 74, just about one year after the book containing these fulminations against him appeared.

Another target of Motta's wrath was Grady McMurtry. Another follower of Crowley, McMurtry had established a working branch of the O.T.O. in the U.S. After Germer's death, he claimed his chapter of the O.T.O. was the true one, on the basis of certain warrants issued by Crowley, which were however not ratified by Germer at the time of the latter's death. Apparently McMurtry felt that his group was the most worthy successor, lacking any more definite contender. Motta, who felt that \*he\* should be the head of the O.T.O. after Germer's death, hated McMurtry insanely. His expulsion of McMurtry from the O.T.O. is remarkable in the elegance of its language. At this point in his psychological development, Motta has become Capitalized:

"You have stolen Our personal property and the property of Our Office, and have put both to the service of your spite and jealousy. ... "You are hereby declared a traitor to your own Higher Self and to Us. Let you die the death of a traitor; let the memory of your infamy remain as a warning and reproof to future generations of Brethren, yet may you live long enough in your sadness and misery to perceive how your lack of moral courage and integrity your deliberate abandonment to the animal in you, has harmed your country, your fellow citizens, and the entire world. ... "Should you, on this day forth, attempt to speak in the name of the O.T.O., the police forces of your country will be brought to bear on you. You are a liar. You are a traitor. You are unworthy. You are unfit. You are outcast. Die in your misery." (p. 459)

One year less two days after this baroque anathema, McMurtry died, at the age of 66. Whether this was a coincidence or not I leave to your speculation, but in view of Regardie's death, I'm starting to worry a little bit.

However, on the day of McMurtry's death, his branch of the O.T.O. was notified of a legal decision in which they were assigned all copyrights and trademarks of the O.T.O. Motta was fined \$35,000 for several cases of libel, and was prohibited from representing his group as the O.T.O. He was allowed to use the name "Societas Ordo Templi Orientis" or S.O.T.O.

### Descent into paranoia -----

Motta usually writes of himself in the third person. It got to the point where, in some cases, he would refer to himself of the third person, then interpolates a commentary in brackets on what he had just written, also in the third person. The bizarre effect this schizophrenic technique creates is better imagined than actually experienced. Rather than raise the tone of the discourse to the heights he believed appropriate, it instead paints the picture of a writer with several distinctly deteriorated personalities.

From the American Heritage Dictionary: par-a-noi-a (n.) A nondegenerative, limited, usually chronic psychosis characterized by delusions of persecution or of grandeur, strenuously defended by the afflicted with apparent logic and reason.

Keep in mind this definition when reading the following passages. Referring to himself, he writes:

"He had been blacklisted in the United States when he first got in touch with Mr. Germer; Hoover had not failed to learn of that...When Motta published "Calling the Children of the Sun" in Portuguese, printed Liber Aleph in English, and started shipping copies of a Crowley book to the United States, the entire Brazilian 'intelligence' services were put on alert." (p. 357)

Either the Brazilian intelligence services were sorely in need of something to do, or Motta was a figure of international importance. This sort of thing illuminates a sardonic comment he makes later: "As everybody knows, Motta is paranoid as well as megalomaniacal." (p. 455)

The Master smiles upon accusation of his egotism:

"The selfishness of the Master is a fact; he or she cares absolutely nothing but for his or her Work; disciples are merely tools in the game of His or Her life, to be used (but not abused) or discarded as a child does to lead soldiers or to dolls. The Master is merely an instrument of the of the Gods; His or Her "personal" life is an illusion; the Work which he or she was sent to do is all that matters..." (Crowley & Motta, 1983, p. xix)

Reverting to the first person for a chatty aside, he writes:

"I myself have often been accused--and from the point of view of the accusers, I admit sometimes with cause--of being unfeeling, overbearing, totally involved in myself, ruthlessly cold and, of course, always pitiless... .. "But to be a servant of humanity is not to be babysitter to knaves or fools..." (loc. cit.)

A more concrete example is forthcoming:

"He [Motta] had been living against his will, with a woman towards whom he foolishly felt personal responsibilities (she was the mother of his two children)..."

What a terrible waste of a Master's valuable energy that he should concern himself with such trivialities as the well-being of his children. He dismisses this nuisance with the comment: "[Since Motta's personal adventures are irrelevant to this account, we will not go at length into this]" (p.484) However, in the same volume he tells of an individual "misrepresenting himself as an O.T.O. member": "the Supervisor General [apparently Motta himself] ascertained that Mr. Gernon had left behind an abandoned wife, an abandoned retarded child, and an abandoned \$5000 debt to his Lodge brethren." It seems that Motta has a flexible interpretation of one's duty to one's wife and children.

I have dwelt at length on Motta, first, because he is so flamboyant, and second, because he showed himself to be prey to the same kinds of mania, paranoia and self-delusion as his idol, Aleister Crowley. In middle and later life, Crowley was fanatic about lawsuits. He won a trivial libel case (he was awarded 50 pounds), and, emboldened by his success, essayed another which he lost ignominiously. In a book Laughing Torso, an artist who had met Crowley in 1920's Paris characterized him as a black magician. Crowley decided his character was being defamed and decided to sue, although his counsel had misgivings. Not too surprisingly, the defense made mincemeat of Crowley's case by simply recounting his more outrageous misadventures, the treatment of his wives, mistresses, and students, and presenting for evidence some of his pornographic and blasphemous writings. (I read Laughing Torso, and if anything the references to Crowley were amazingly mild.)

To return to Motta: In a discussion of copyrights of Crowley's material, he writes:

"But as neither Metzger nor McMurtry ever had sanction from Mr. Germer or from his executor to represent the Crowley copyrights (we are now in the process of proving this in court) their 'permission' to Regardie is no better than the permissiveness he allows himself." (p. xviii)

Unfortunately for Motta, as we've seen above, things did not work out as he had planned.

## So what does this mean to me? -----

So how does one go about with a self-analysis? Is it even possible to be objective enough to do this? Note the difficulty with the definition of paranoia: suppose a person really \*is\* being persecuted, yet is unable to collect or present enough evidence to convince law enforcement authorities to help. Remember also that sufferers defend their positions with "apparent logic and reason."

## Notes ----

(Bardon, 1976) Initiation into Hermetics, 3rd ed., Franz Bardon. Dieter Rugeberg Verlag, Wuppertal, West Germany. (In my opinion, this is one of the best books on practical occultism ever written. My reason for including it in this list is its insistence of painstaking self-examination and psychic/psychological balance. However, the English translation is somewhat puzzling in places. The book was first published in German (and is still available in that language), but may have been originally written in Czech.)

(Crowley, 1929) Magick, Aleister Crowley, p. xxi. 'Perdurabo' [I will endure] was Crowley's magical name.

(Crowley & Motta, 1983) Magick without Tears, vol. 1

(Fortune, 1967) Sane Occultism, Aquarian, 1967. (Orig. ed. 1929, reprinted 1967, 1979, etc.)

(Regardie & Hyatt, 1984) 'The Proper Attitude Toward Mind-Body,' essay by Israel Regardie and Christopher S. Hyatt in The Complete Golden Dawn System of Magic, Falcon Press, pp. 19-20. (This somewhat obscure and clumsy writing is puzzling in light of the clear and reasonable prose of Regardie's other work.)



# ORACULUM

by The Sophist

I found many things in the  $\text{S}$ , I made a salt out of them, a blood-red  $\text{O}$  also a meadow-green  $\text{O}$  and a  $\text{V}$  liquid mercury, in the following way: I took an ore of  $\text{Z}$ , reduced it to a fine powder, placed it in an earthenware pot and placed it on a coal fire  $\Delta$ , so that the pot becomes hot, but not too hot as not to melt the ore. I let it to heat for 2 to 4 hours, to calcine gently until it swelled; then I withdrew the pot from the fire, I reduced its content to powder, and calcined it once more, and so on, until only grey ashes remained, which I reduced to powder and put into a retort; then I poured a  $\text{V}$  strong vinegar onto it and placed the retort on a gentle heat (First extraction); then this vinegar  $\text{V}$  took on a brilliant yellow color, and I poured it and added some new vinegar onto it and duplicated the operation until the vinegar no longer took on any color; then I poured all the colored vinegars together, I took the  $\text{O}$  (residual substances) off the retort, dried them and calcined them again, then I poured freshly distilled vinegar on them and extracted all the salt, until the vinegar no longer dulcified, but remained such as I had poured it. Then a white limestone earth  $\text{V}$  remains which is useless. I poured all the vinegar together into a retort, placed the latter in a  $\text{S}$  sand bath and distilled it entirely; I obtained thus a thick salt, quite dry that I heated with gentle heat; it started then to melt, I stopped the heat; I broke the retort, took the salt, reduced it to powder, and sprinkled distilled water over it (Second extraction) and extracted it again. I poured this solution slowly in order to separate the fecibus (impurities) from it and continued until everything became pure once again, cleaned of all fecibus. I distilled it again in a retort and heated it with a strong heat  $\Delta$ , then I extracted it again and again new feces came out; (Third extraction) I separated them again and distilled the water out of its salt. Then I again poured distilled water  $\text{V}$  on it and my solution became blood-red in color, which pleased me. I distilled this water again and it became as black as tar (Fourth extraction) I finally heated it with strong heat, then it flowed together to become a blood-red, sweet, and clear salt. I was pleased again, for I thought I had obtained the true Carfunkel, for all philosophers used to say that the Salt of Metals is the Philosophers' stone. I must admit, in truth, that it was a medicine of great potency, and I had read in the philosophers' books that the force to transform the coagulation of Mercury into  $\text{O}$  or  $\text{D}$  lies in the heart of  $\text{Z}$ . I placed 1 Mark<sup>1</sup> of  $\text{V}$  live-mercury in a deep mortar, when the mercury started to heat, I placed 1 part of my stone onto it, the latter started to melt and covered the mercury with a blood-red skin; I gave it a slightly stronger fire  $\Delta$ , and the matter collapsed in the mortar; I let the heat  $\Delta$  cool down, withdrew the mortar and thought that the whole would be transformed into a medicine; but it became otherwise; for my mercury  $\text{V}$  appeared hard and seemed heavy, but when I broke it in two parts and added to one of the parts 4 parts of lead, reduced them while blending them in a cupel, then I saw to my disadvantage that everything volatilized except for 1 part and 1 fifth (quint) of the most beautiful silver  $\text{C}$ , of which half was gold  $\text{O}$ , upon separation. I tried it with the other part and found nothing more. I saw there that something of the mercury had transformed into gold and silver. I went through 100 attempts, but could get nothing more out, and left that work aside. The truth was that I could not extract anything more from it, but I was so enamored with

<sup>1</sup>One mark = 244.5 gr

## ORACULUM, continued...

this work that I started other ones. But tell me why did this salt not transform the mercury all the way into gold but only into silver?

### Wisdom

You did not purified your salt enough, for the acid does not leave it in this manner, and this prevented the salt from being capable of penetrating. It is said: the salt of Metals is the philosophers' stone but one pound of lead ore barely contains 1 quint of true salt, however of a strength much greater than your salt; that is why you should pay good attention to the following cause: when you have extracted your salt of ♄ for the third time and you have distilled the water to the state of dryness, you should have left it to heat in an enamelled mortar until it melts, which happens easily, and rapidly pour it, once it has cooled down, reduce it to powder and put it in a retort (for through calcination and fusion, most of the acid leaves); pour onto it a highly rectified wine alcohol and extract it again; the alkali of the vinegar will thus remain, put all the extractions together and distill them in a water-bath in order to drive the spiritus vini (wine alcohol) out, then the true Sal Saturni will remain, which, once more extracted with distilled rainwater, will first dissolve like blood and will coagulate with difficulty. And now this is the true Quinta Essentia or the nucleus (kernel) or balsam of Saturn or even a true Sal Metallorum which coagulates the ♀ mercury around it into gold ☉ or silver ☾. Melt 2 parts of gold; when it becomes liquid add 1 fifth (quint) of salt, the latter will instantly unite with what is similar to it, that is, the salt as an intermediary between mercury ♀ and sulfur ♂ in the gold; the salt will dominate therefore the mercury ♀ and the sulfur ♂ in gold while rejecting its ♁ earth, and the rest will be together as a red salt, sweeter than sugar, a gram of which colors a glass of wine like blood, which constitutes a potent remedy for the human body. What we can do with the rest, you will eventually see it, for it is a real treasure.

### The Sophist

Oh! there was not enough salt! I also attempted to make the oil of metals out of it and took for this purpose the salt mentioned above, mixed it with a beautiful ☉ white limestone, poured it into a retort and thus obtained a spiritum of ♄ calcium salt and a blood-red oil, this I again overdistilled in a ♁ water-bath, thus blood-red oil formed; I put the oil into a phial and have congealed it together, that is to say, I poured 1 part of this oil on 2 parts of calcium ♄ salt on it, I blended it, but could not do any more with it than with the preceding one, except that it was an excellent medicine.

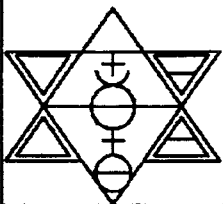

The Stone

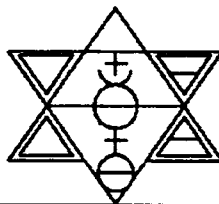

Page Fourteen

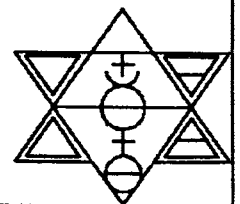

November 1994

# Cleaning The Amalgam Out of a Crucible, "in a Jiffy"

by *Nicolas and Pernelle*  
translated from the French

The leaching of the amalgam is the epitomy of painstaking work, an endless story...

In fact the excess regulus remains glued on the amalgam as a fine and black powder, and it is almost impossible, for all practical purposes, to extract it totally, even after a number of leachings.

One way of separating the antimony from this powder is to render the antimony soluble with a product that should be: easy to obtain, no-caustic and non-toxic.

The tartaric acid L(+) -  $\text{HOOC}-(\text{CHOH})_2-\text{COOH}$  meets these requirements. Very water-soluble, it is used in foods, particularly fruit juices and gaseous beverages (French product code E 334). (It is always useful to read the composition of the food we ingest.) In the presence of antimony, it immediately forms a soluble mixture easy to eliminate. Then you just have to leach the amalgam.

Two products similar in their compositions have been tested and were equally effective.

\* The double tartaric L(+) of potassium-sodium  $\text{KOOOC}-(\text{CHOH})_2-\text{COONa}$ , also called salt of *Seignette* or salt *de Rochelle*, because it was first obtained by Seignette, an apothecary in La Rochelle (France). Also very soluble, its effect is slightly less dramatic, but as a fluxing agent it has the advantage of belonging to the paraphernalia of any adept aspiring to the Flamel Way.

\* Bitartrate or tartaric L(+) of potassium  $\text{HOOC}-(\text{CHOH})_2-\text{COOK}$  or cream of tartar is little water-soluble and therefore its use is not as easy. On the other hand it can be easily obtained from wine-growers. This product is actually the main component of red tartar which also contains calcium bitartrate and coloring agents. It is also used as a fluxing agent for the preparation of the regulus. Its action on antimony could form the emetic tartar, a complex made of tartarate of antimony and of potassium.

It is however essential to reduce it to powder, for instance in a coffee grinder, otherwise the dense and soluble grains stay at the bottom of the container and it takes longer to rince the out.

## WE PROPOSE THE FOLLOWING METHOD:

Put the amalgam at the bottom of a one-liter glass jar. In order to recoup the red powder, triturate with a glass or wooden rod, or as was suggested with an electric blender equipped with a whipper for dough, or else shake it energetically with about 3 liters of de-ionized water.

## Cleaning, continued...

After the entire amount of the water has decanted, add to the amalgam about the fourth of its weight of the chosen product, tartaric acid, potassium-sodium tartrate, or finely powdered red tartar. Triturate and blend until you obtain an homogenous powdery mass. Add 400 to 500 ml of warm water (40 to 50 C). Triturate for one or two minutes. Decant and rince in warm water. If needed, do the same operation again with a few spoonful of the product, and again rince well.

The three products also allow you to easily clean the containers that were filled with antimony, and particularly the crucibles. Put 2 to 3 spoonful of product into the crucible. Pour boiling water over it so as to cover the sides.

When the boiling has ceased, clean with a small brush, and with a knife, grate the more resistant residues. If the crucible is very dirty, boil it for a few minutes in water to which some of the product has been added.

The black powder tends to fix itself on plastic containers and utensils, so avoid using them. Reminder: if you work with antimony, it is recommended to wear gloves, goggles and a mask; this product is an irritant and inhaling it could cause nose bleeds.

Note that these three products come directly, or after transformation, from the de-tartaring of wine vats and tuns that contained wine.

### NOTE:

\* L(+). L indicates that the product is a part of the L series, as opposed to the D series, symmetrical in relation to a mirror. These letters are conventions.

\* (+) or (d) indicates that the product is turning right or dextrorotatory and deviates polarized light to the right, as opposed to (-) or (l) which characterizes a product turning left or levorotatory which deviates polarized light to the left. This rotatory power is an experimental observation.

These two properties are independent. Therefore we can have D(+), D(-), L(+) or L(-) products.

While observing tartaric acid crystals Pasteur studied the optical properties and the dissymmetry of matter, whose philosophical and symbolical consequences are very significant.





# Creating Seven Planetary Plant ENS

by *Nicolas and Pernelle*  
translated from the French

"The Ens manifests the highest initiatic virtues of the plant it is made from." (M. Auger)

The Ens or the Ens tinctures, whose preparation is once again described below, have a lesser initiatory power than that of the plant stones. However their powers can be compared to that of elixirs. While the elements Earth, Water, Air, and Fire are balanced in the elixirs, in the Ens tinctures the element Fire predominates. On the other hand, Ens tinctures have the great advantage of not requiring any particular material and can thus be made by any beginner eager to undertake spagyric work.

## PRINCIPLE

Potassium carbonate (or salt of tartar) liquefies (becomes deliquescent) when it absorbs the humidity of the air - the vehicle of the Universal Fire or Prana, that exists in great abundance in the Spring and Summer.

The solution obtained is a viscous liquid called deliquescence or "oil of tartar". The salt which was dead is thus revived and is going to communicate its Fire energy to the plant, of which it extracts the essential principles while taking on a lesser or brighter red color.

These essential principles (Sulfur) charged in Fire by the Salt, are to be transferred to the Spirit of wine or alcohol (Mercury) and will yield a tincture, usually of a lighter or brighter yellow.

## MATERIAL AND PRODUCTS

Obtain:

- 400 to 500 ml air-tight glass jars, preferably with a non-metallic top;
- Smaller 30 to 50 ml flasks;
- 1 kg of potassium carbonate;
- Approximately 700 ml of wine Spirit, preferably rectified, or otherwise regular 90% alcohol (at least) that you can find in liquor stores;
- 80 to 100 gr of each of the 7 plants corresponding to the 7 planetary levels.

## PREPARATION OF THE DELIQUESCENCE

Spread on glass or porcelain dishes a thin layer of potassium carbonate (1 to 2 cm maximum). Expose outside away from the sun or the rain, for example close to an open window. The salt will become pasty and then will liquefy. Filter the liquid on absorbent cotton, as it forms. **CAUTION: THIS PRODUCT IS TOXIC. AVOID CONTACT WITH THE SKIN.**

## Creating ENS, continued...

### HOW TO PREPARE THE ENS

Introduce 50 to 60 grams of the finely powdered plant into the flask. Add an equal volume of oil of tartar, approximately 100 ml. Blend thoroughly. Let this mixture sit in a warm place for about 10 days, close to a heater or in the sun, while protecting it from light, or even better leave it in an oven at 40 C.

Stir once in a while. Filter the solution through absorbent cotton; it should have turned bright red. And pour it into a previously cleaned flask.

Add an equal quantity of alcohol and let sit in the same conditions, while stirring firmly every day until the color remains the same, usually golden yellow.

Collect the top alcoholic layer - the Ens tincture - by decantation or with a serynge for example.

### USE

Ingest about 10 drops in half a glass of water on the day ruled by the planet of the plant, in the hour following sunrise.

Note down the dreams or the experiences you may have as well as the phases of the Moon during which they occurred.

In Spagyrics Lesson # 8 there are lists of plants corresponding to the seven planets. Some among the most common are listed in the chart below:

Day	Planet	Sephira	Plant
Monday	Moon	Yesod	Speedwell Mouse ear
Tuesday	Mars	Geburah	Madder Hawthorn
Wednesday	Mercury	Hod	Caraway Lavender
Thursday	Jupiter	Chesed	Lemon Balm Borage
Friday	Venus	Netzach	Lady's Mantle European Vervain
Saturday	Saturn	Binah	Horsetail Fumitory
Sunday	Sun	Tiphereth	Roman Camomile St. Johnswort



400 Titles

## Rare Book Reprints

Alchemy Ancient Wisdom Astronomy Baconian Eastern Thought Egyptology Esoteric  
Freemasonry Gnosticism Hermetic Kabbalah Metaphysical Mystery Schools Mystical  
Mythology Occult Philosophy Psychology Pyramids Religions Rosicrucian  
Science Spiritual Symbolism Tarot Theosophy and many more!

✓ Perfect Bound Paperback Reprints ✓ Acid-free paper for long life ✓ Most books with title and author on spines ✓ New titles published weekly  
Trade discounts ✓ Visa and Mastercard accepted ✓ Phone Orders ✓ Fast Service ✓ Full Catalog with complete descriptions available

**Kessinger Publishing, P.O. Box 160-LPN, Kila, MT 59920 (406) 756-0167 Fax (406) 257-5051**

All books must be prepaid in US funds. Shipping and Handling Charges: \$4.50 for the first book, and .50 for each additional book. Foreign orders multiply total by 15% for surface or 45% for air mail.

- ADIRAMLED, Art of Alchemy or the Generation of Gold, 73 pages, ISBN 1-56459-319-3, \$12.95  
ALBERTUS, FRATER, Golden Manuscripts, 160 pages, ISBN 1-56459-303-7, \$16.95  
ANONYMOUS, Compendium of Alchemical Processes, 173 pages, ISBN 1-56459-344-4, \$16.95  
ANONYMOUS, Hermetic Triumph and the Ancient War of the Knights (1740), 220 pages, 1-56459-280-4, \$24.95  
ANONYMOUS, Lives of the Alchemystical Philosophers, 400 pages, ISBN 1-56459-352-5, \$27.00  
ASHMOLE, ELIAS, Theatrum Chemicum Britannicum, 633 pages, ISBN 0-922802-890, \$32.50  
BEGLEY, WALTER, Biblia Anagrammatica, 212 pages, ISBN 1-56459-016-X, \$9.95  
BEGLEY, WALTER, Biblia Cabalistica, 158 pages, ISBN 1-56459-017-8, \$9.95  
BOYLE, ROBERT, Sceptical Chymist, 452 pages, ISBN 0-922802-90-4, \$36.00  
CHAMBERS, Alchemy and the Alchemists, 64 pages, ISBN 1-56459-005-4, \$9.95  
COCKREN, A., Alchemy Rediscovered and Restored, 158 pages, ISBN 1-56459-148-4, \$17.95  
ENCYCLOPEDIA BRITANNICA (1771), Eighteenth Century Chemistry as it Relates to Alchemy, 173 pages, ISBN 1-56459-304-5, \$17.95  
FERGUSON, JOHN, Bibliotheca Chemica, 1085 pages, ISBN 1-56459-001-1, \$75.00  
FIGULUS, BENEDICTUS, A Golden and Blessed Casket of Nature's Marvels, 391 pages, ISBN 1-56459-180-8, \$19.95  
GARSTEN, E.J., Secret Fire, 120 pages, ISBN 0-922802-20-3, \$17.95  
HAMILTON-JONES, J. W., Baecstrom's Alchemical Anthology, 152 pages, ISBN 1-56459-154-9, \$17.95  
MUIR, M.M. PATTISON, Story of Alchemy, 208 pages, ISBN 1-56459-019-4, \$18.95  
PARACELUS, THEOPHRASTUS, Archidoxes of Magic, 160 pages, ISBN 1-56459-171-9, \$17.95  
PETRUS OF FERRARA BONUS, New Pearl of Great Price, 441 pages, ISBN 1-56459-142-5, \$29.95  
PHILALETES, EIRENAEUS, Collectanea Chemica, 160 pages, ISBN 0-922802-81-5, \$16.95  
RALEIGH, A.S., Science of Alchemy, 172 pages, ISBN 1-56459-007-0, \$16.95  
RALEIGH, A.S., Speculative Art of Alchemy, 191 pages, ISBN 1-56459-006-2, \$16.95  
RALEIGH, DR. A. S., Hermetic Fundamentals Revealed, 127 pages, ISBN 1-56459-370-3, \$14.95  
READ, JOHN, Alchemist in Life, Literature, and Art, 120 pages, ISBN 1-56459-210-3, \$17.95  
READ, JOHN, Prelude to Chemistry, 328 pages, ISBN 1-56459-015-1, \$24.95  
READ, JOHN, Through Alchemy to Chemistry, 206 pages, ISBN 1-56459-013-5, \$19.95  
REDGROVE, H. STANLEY, Alchemy Ancient and Modern, 141 pages, ISBN 1-56459-143-3, \$17.95  
REGARDIE, ISRAEL, Philosopher's Stone, 204 pages, 1-56459-282-0, \$17.95  
RIPLEY, Compound of Alchemy, 90 pages, ISBN 1-56459-077-1, \$12.00  
RULANDUS, MARTINUS, Lexicon of Alchemy, 466 pages, ISBN 0-922802-92-3, \$30.00  
STOLTZIUS VON STOLTZENBERT, DANIEL, Little Mystic-Magic Picture Book, 231 pages, ISBN 1-56459-027-5, \$15.95  
TAYLOR, F. SHERWOOD, Alchemists, Founders of Modern Chemistry, 246 pages, ISBN 1-56459-002-X, \$24.95  
VALENTINUS, BASILUS, Triumphal Chariot of Antimony, 205 pages, ISBN 1-56459-021-6, \$17.95  
WAITE, ARTHUR EDWARD, Alchemical Writings of Edward Kelly, 220 pages, ISBN 1-56459-166-2, \$19.95  
WAITE, ARTHUR EDWARD, Hermetic and Alchemical Writings of Paracelsus, 800 pages, ISBN 0-922802-1-81, \$37.95  
WAITE, ARTHUR EDWARD, Hermetic Museum Restored, 700 pages, 1-56459-284-7, \$39.95  
WAITE, ARTHUR EDWARD, Secret Tradition in Alchemy, 413 pages, ISBN 0-922802-83-1, \$33.00  
WAITE, ARTHUR EDWARD, Three Famous Alchemists, 186 pages, ISBN 0-922820-84-X, \$16.95  
WAITE, ARTHUR EDWARD, Turba Philosophorum, 211 pages, ISBN 0-922802-99-8, \$14.50

# TRIAD

125 West Front Street, Suite 275  
Wheaton, Illinois 60187  
Fax/Phone (708) 665-1417

Triad was born more than ten years ago out of our efforts to obtain materials for our personal alchemical research. Since that time, we have helped many people to obtain unusual or hard-to-find materials. We are currently listing some specific products which we have in stock that are of interest to researchers. The materials listed here are (with the exception of antimony ore) in very limited supply, and we are not certain that we will be able to replenish our stocks once these supplies are exhausted.

**All listed materials subject to prior sale, due to demand and limited supply. Refund sent for out-of-stock materials unless you specify alternative choices at time of order.**

**ANTIMONY ORE:** Purest stibnite available. Bolivian, almost pure  $Sb_2S_3$ . Can be used without separating gangue when making regulus. Same as now used by French LPN for research. Prices: 1-5 lbs, \$10/lb; 6-24 lbs, \$9.00/lb; 25-49 lbs, \$8.00/lb; 50+ lbs, \$7.25/lb.

**ANTIMONY TRIOXIDE:** Commercial, technical grade. Price per pound: \$6.00.

**CERUSSITE:** Native lead carbonate ore from Arizona. We bought the entire stock of this material from a minerologist who collected all available cerussite from this site in 1992. Quality is mixed. Small amounts of crystalline material as inclusions. Very limited supply. Price per pound: \$5.00.

**LEAD CARBONATE:** Commercial, technical grade. Price per pound: \$7.50.

**LEAD OXIDE, RED:** (*Minium*) Commercial, technical grade: Price per pound: \$9.00.

**SEA SALT:** From France. Not the 'flower of sea salt' which is now sold out, this is the normal quality of sea salt collected by evaporation in clay beds in northern France. Used as a matrix for synthetic plant stones. Price per pound: \$5.00

**SULPHUR:** Native sulphur from western US. Medium to high quality. No large crystals. \$8.00/lb.

**SULPHUR:** Italian native sulphur. Medium quality, with some large crystalline masses. \$9.00/lb.

**SUNDEW:** (*Drosera rotundifolia*) Imported for us from Europe. Unique, insect eating plant receiving much interest in medicine. Said by LPN to be a 'vegetable antimony' on the level of Malkuth, with interesting experimental possibilities. Price per pound: \$15.00.

**TARTAR:** Red wine tartar from France. We periodically have obtained small quantities through LPN France. Price per pound: \$8.00. Shipped in plastic bag.

**Our inventories include absolutely pure essential oils, herbs, books on alchemy and other esoteric topics, chemicals, mineral ores and laboratory equipment. Please inquire.**

*He's back!*  
(THE LAST GREAT ALCHEMIST IN PRINT)

# ALCHEMICAL WORKS: Eirenæus Philalethes Compiled

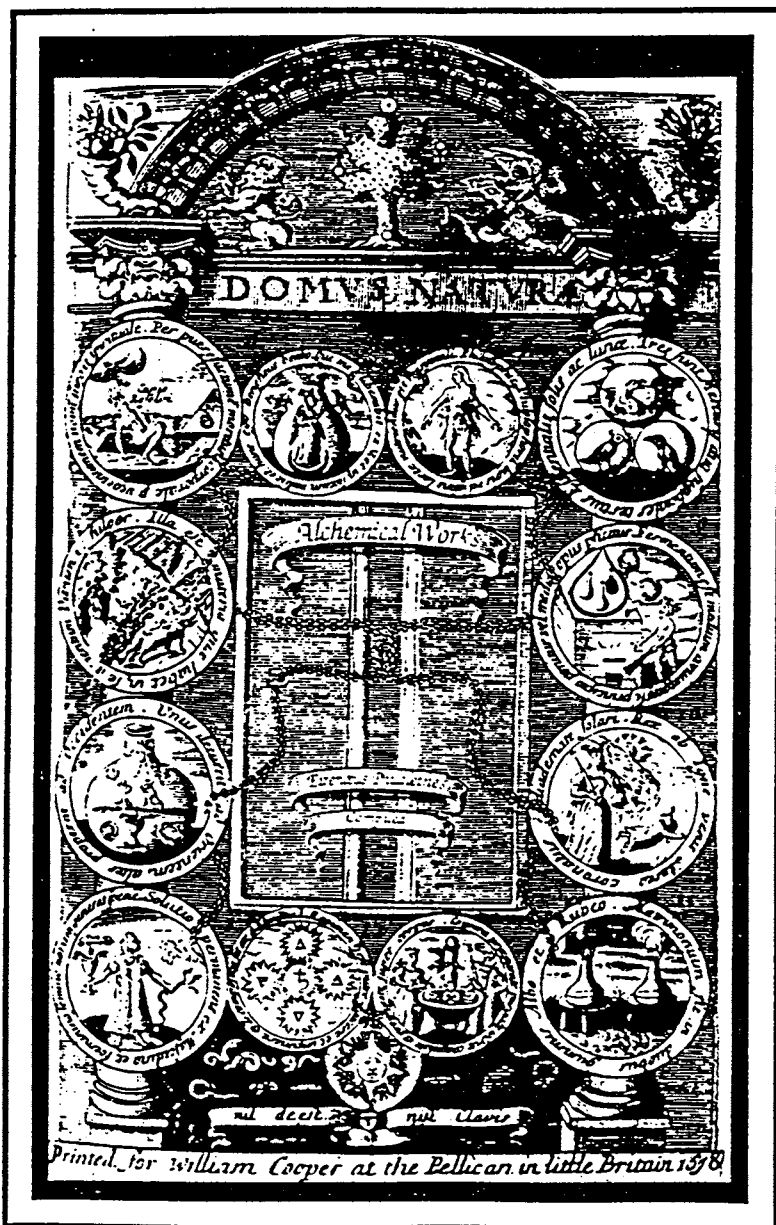

hard cover 592 pages indexed a.f.p. ISBN 0-9640067-0-7 \$60.00

\$65.00 U.S. Postage paid to:

**LPN-USA**

Box 11218

Boulder, CO. 80301

Eirenæus Philalethes, mysterious alchemical adept of the seventeenth century has elicited intrigue, study, and controversy for historians, littérateurs, and scientists since these works were published beginning in the mid-1600's.

This volume is unique. It is the only to contain all Philalethes' works currently available in English, and it is indexed.

Original format has been carefully preserved throughout, offering readers access to complete, authentic, and legible text and content for their enjoyment and studies, without having to resort to the microfilm copies previously available to most readers as the only source for much of the text contained within.

The practice of alchemy has been perennial for all of written history, woven through one civilization and into the next, often tying them together. It is a science, a philosophy, a mystery, and a quest. The very word connotes a magic transcending our limited beliefs about the laws of nature. It was used as a tool of charlatans, who did much through their deceit to destroy the reputation of the science. Much more often it has been a field of study for great minds. C. J. Jung spent his last twenty years illustrating its value in framing the workings of the subconscious through alchemy's rich use of metaphor. Sir Isaac Newton poured over Philalethes' tracts, finally preparing what he thought to be *Philosophic Mercury* in 1675.

The essence of alchemical writings has been consistent through the centuries, while the details have been inscrutably and defiantly deceptive. Philalethes is called the last great alchemist in print. This collection presents a treasure map for many uses.

# SEMINAR VIDEOTAPES AVAILABLE

*The first and second Philosophers of Nature Seminars were video recorded and the videotapes are now available.*

A. Video recording of 1st Philosophers of Nature Seminar - 2, 3, & 4th October 1992.

Contents of package:

1. Three video cassettes (Over 15 hours of material).
2. Table of contents of the videotapes, keyed to time for quick searches (if your VCR tracks time).
3. Complete graphs and written material provided by LPN France on subjects covered in the seminar.

Price = \$69.95, post paid.

B. Video recording of 2nd Philosophers of Nature Seminar - 23 & 24 of April 1993.

Contents of package:

1. Two video cassettes (9 1/2 hours)
2. Table of contents of videotapes.
3. Complete graphs and written material provided by LPN France on subjects covered in the seminar.

Price = \$49.95 post paid.

Attention Students of Qabala and the Western Mysteries...

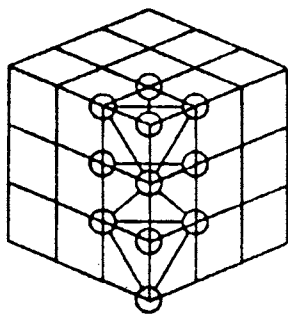

*"In the study of Qabalah there is no more important glyph than the Cube of Space..."*

Paul Foster Case

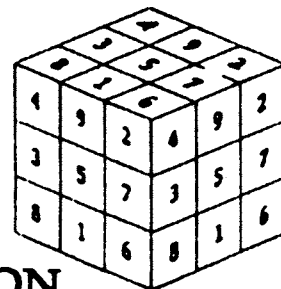

## THE CUBE OF SPACE: THE CONTAINER OF CREATION

a book by Kevin Townley

Topics include:

- \* Generation of the Cube of Space through geometry.
- \* The Magic Square of Saturn.
- \* Relationship of the Cube to the Tree of Life.

- \* Placement of the Tarot (Minor Arcana) on the points of the Cube.
- \* The Cube's relationship to the Macro and Microcosm.
- \* The Cube of Space in the Four Worlds.

To order send \$45.00 plus \$3.00 for postage to  
Archive Press, Box 11218, Boulder, Colorado 80301.

*"As Above, So Below"*

*When you understand the process of Divine Creation on the macrocosmic level, you can apply those same principles on a personal (microcosmic) level!*

# Philosophers of Nature Annual Report

## *from the President*

There has been some question raised concerning the PON's income. One of our members asked, "There are 1,000 of the PON and each member is paying at least \$100.00 a year for lessons, where is all the money going?"

Our last report concerning LPN France stated there were about 1,000 members (in France). In the English speaking world there are about 100 (one hundred) dues paying members with about 75 receiving lessons. There is not this tremendous flow of money running into the bank account of PON. The officers receive no money for their time and service.

The following is our report for the business year ending March 1st, 1994; total income for the 93/94 fiscal year was \$21,170.03 and our expenses were \$21,160.13

### Annual Report for Fiscal year 1994

(3/1/93 - 3/1/94)

#### INCOME

Income from lesson subscription	\$ 18,825.94
Income from donations	520.00
Other income (tapes, publications, etc)	2,170.09
TOTAL INCOME	\$ 21,516.03

#### EXPENSES

Bank Charges	\$ 217.10
Cost of Goods - Materials	442.97
Translation Costs	4,102.50
Secretarial salary	2,160.00
Office equipment	1,526.00
Legal and Professional Fees	817.50
Equipment repairs	436.65
Office supplies	609.79
Copies	3,264.55
Postage costs	2,811.04
Phone costs	3,460.69
Travel expenses	800.00
Member refunds	150.00
Miscellaneous expenses	341.34
TOTAL EXPENSES	\$21,160.13



*A THOUGHT BY JEAN*

*At Midnight, The First of January 1993*

*Within REALITY  
There is neither god or devil  
or jesus or allah  
or buddha.  
There is only each of us  
in one SINGLE Being  
I in UNITY,  
YOU and ME in duality.  
On this eve where I am  
YOU AND ME,  
I know I am  
a child of NOTHINGNESS.  
That before our Father -  
NOTHINGNESS -  
I shall dominate him, I must  
in order to become  
THE INFINITE BEING of ETERNITY.  
Apart from this  
there is nothing else  
but a temporary and necessary  
ILLUSION.*



**About The Stone**

The Stone is published three times a year, in March, July, and November, Primarily for the benefit of the membership of the Philosophers of Nature. We hope to get member's feedback regarding what they would like to see in it. Articles, photographs, drawings, letters, and comments from members or others are solicited for submission to the Editor for evaluation. Submissions and advertising should be sent to The Stone c/o Ken Miller, 405 West Washington Street, Suite 314, San Diego, CA. 92103-1994. Telephone (619) 528-4521. E-mail address coming soon. Deadline for submissions and advertising are as follows: February 20th for the March issue; June 25th for the July issue; October 25th for the November issue.



**Advertising**

The Stone accepts advertising, both display and classified ads. Rates are as follows: Full page: \$100.00; Half page: \$55.00; Quarter page \$30.00; Classified ads are \$0.05 per word. For more information call or write the Editor, Ken Miller, at 405 West Washington, Suite 314, San Diego, CA 92103-1994. Telephone (619) 528-4521. Calls will be returned collect.



**Subscription to The Stone  
& Membership Information**

The Stone is included in the cost of membership. Non-members may subscribe at the rate of \$20 per year (three issues). Subscription requests should be sent to the administrative headquarters: Philosophers of Nature, P.O. Box 11218, Boulder, CO. 80301. Any questions about membership should also be sent to the Boulder address. Membership Office Manager Karen High can also be reached at (303) 443-8199; you may leave a message for her Monday through Friday from 9am to 5pm Mountain Time.



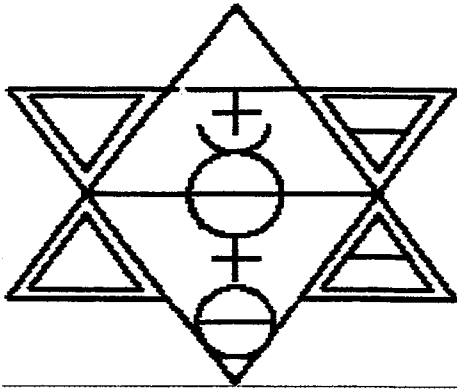

# The Stone

& ORA ET LABORA

Journal of The Philosophers of Nature

Issue Number 12

March 1995

## Secrecy, Revelation, & Desire

*"Whosoever would know Secrets, let him know how to keep secret things secretly; and to reveal those things that are to be revealed, and to seal those things which are to be sealed: and not give holy things to dogs, nor cast pearls before swine. Observe this law, and the eyes of thy understanding shall be opened, to understand secret things; and thou shalt have whatsoever thy minde desireth to be divinely revealed unto thee. Thou shalt have also the Angels and Spirits of God prompt and ready in their nature to minister unto thee, as much as any humane minde can desire." The first Aphorism from the Arbatel.*

"Keep secret things secretly," this thought has been emphasized throughout the ages, but have you ever paused to consider the "reveal those things that are to be revealed"?

Here is a story: A lone alchemist slaves away twenty years in his lab, combing the old books, learning by trial and error, finding illumination from one passage only to encounter the opaque in the next. He succeeds in many works, others elude him. He attends, for example, a PON seminar, scribbling notes, soliciting comments, careful not to tip his

hand and "reveal" just how far he has gotten, what mistakes he has risen above, and what sweet triumphs he has tasted. A few years later having ultimately failed in the Great Work, his body surrenders his soul, and his work is left unfinished. Sometime later in another part of town a new young alchemist begins his quest. The story rolls on *and the wheel is reinvented time and time again.*

The LPN was founded, I believe, to shatter the long tradition of isolation and elitism in alchemy and create a space where individuals could gather in a "no master, no student" relationship; that is, people helping people along this journey as colleagues and friends. Furthermore, LPN teaches that the true secrets cannot be told simply because there is no way to tell them! For example, you may reach a point in your work where you must leave it in a philosophic oven undisturbed for a period of weeks. Exact timing and temperature control are intuited during the process. Even if you communicated the details to someone else, following them would only bring heartbreak due to geographical, astrological, weather, and who knows what other variables are present. This is the ORA in ora et labora, you are

praying for the insight that will guide your hand in your preparation; another person's work will have slightly different requirements. As far as I can tell, the LPN teaches that you could have a detailed explicit recipe for The Stone of the Wise, but without an inner connection to intuit the particular details of your time and space, success will forever elude you.

Now, once you have made The Stone, prudence dictates that you keep that fact a secret. You hardly want everyone knocking down

*(Continued on Page XX)*

### In This Issue...

Secrecy, Revelation, and Desire	page 1
No Master, No Servant	
by Kevin Townley	page 2
Kabbalah and the Hermetic Tradition	
by Mark Stavish, M.A.	page 3
Glamour	
by Joseph Nolan	page 8
A Homemade Retort for Mercury Distillation	
by Henry Hintz	page 9
Force Fields, Fulcanelli, and Flamel	
by Russ House	page 10
Freemasonry: An Introduction	
by Tim Scott	page 12
Advertisements	pages 14-17
ORA ET LABORA	PAGES 18-19
About The Stone...	page 20

**The Stone, Issue Number 12, March 1995.**  
Published in March, July, & November by  
the Philosophers of Nature. Editor: Ken  
Miller. © 1995 Philosophers of Nature.

# NO MASTER, NO SERVANT!

a message from Philosophers of Nature President,  
*Kevin Townley*

One of the fundamental points of the Philosophers of Nature is that we shall have no masters or servants. This law comes to us from the Fama Fraternitatus, which gives us seven basic rules of conduct.

There are many ways in which this particular rule can be abused. We have seen this law broken in the work place where a boss may use their power to gain undo influence over those beneath that level in the hierarchy.

When it comes to organizations such as the LPN, such an infraction could come from one who considers him or herself more spiritually evolved or perhaps that they have some divine right to take that which they desire regardless of who becomes injured.

It is the intention of the board of the LPN-USA to see that no one is placed above another, and therefore we remain watch dogs for such infractions against our brothers and sisters.

Last Fall we had several incidents where our members were sexually harassed. We have received letters of complaint accusing Marc Cibard of sexual harassment and unwanted sexual contact. He is accused of demonstrating that he has no respect for the integrity of an individuals boundaries.

I wrote a letter to LPN France informing Jean of the complaints the three men made. Because of this problem, in combination with other difficulties, Marc was asked to step down as president. Thus far, after two resignations, Marc has decided that he will hold on to the presidency and the financial accounts of LPN France.

This is a dark time for our brothers and sisters in Europe. As travelers on the path of return we must hold on to the principles on which the LPN was founded and not be distracted by any individual's desire for power, control, or greed and a complete disregard for the need and integrity of the organization.

It has become necessary to distance ourselves from this political drama essentially generated by those who are not working with an open mind and a loving heart.

I ask each and everyone of the members of LPN-USA to stand firm in their personal commitment to the path of return and the principles which guide their feet along the path.

If there is anyone who has been assaulted in any way during the September seminar or any other LPN function, please notify me at the LPN Address,

BOX 11218  
BOULDER, CO. 80301

or call me at (303) 443-8199.

We wish to create the safe environment during our seminars and will not tolerate any infractions of this sort.

I apologize to any member who felt threatened during the Fall seminar. The best way to deal with such things is to bring them out immediately and confront those who feel they have a right to violate another's physical boundaries.

It pains me to write such a letter. There is so much work that needs to be done on an individual as well as a collective level. That we even have to take the time to place our attention on such dribble is a tragedy. The problem facing us is, should we ignore such infractions the disease of greed and lust for power will infect the entire organization and will cause its ultimate death. The LPN is a unique organization. Let us bond together to stand behind Jean and the board of LPN France and protect that which is in immediate danger of being destroyed.

Ora et Labora.



# *Kabbalah and the Hermetic Tradition*

by Mark Stavish, M.A.

The history of Kabbalah is filled with many personalities and events that have shaped not only the development of Kabbalah over the centuries, but Hermeticism as well. While often lost to antiquity, or only remembered by the disciples of their particular schools, it is important to look at some of these illustrious and influential individuals and their contributions to esoteric thought if we are to have a broader and more complete picture of Europe's spiritual development.

Kabbalah, as most readers know, comes from Hebrew and is generally translated as "tradition" or "received oral tradition" It is the unwritten mystical and magical aspects of Judaism that run parallel to the written rules, laws, and rituals of exoteric Jewish thought and philosophy.

What is not generally know however, is that although it existed prior, the word "kabbalah" didn't come into use until the 12th or 13th century to designate the esoteric and mystical thoughts and practices of Jewish philosophy. It was about this time, that Kabbalah, as we understand it, with the Tree of Life and all the sepheroth, also came into being. Like the word that denotes these studies, the Tree of Life also has roots in older traditions and practices. While many schools of kabbalah were, and some still are, exclusively Jewish in orientation, as time went on many were adapted to the Christian world as well as influenced by other schools of mystical and esoteric activity.

Isaac the Blind, a pivotal figure in the study of early 13th century kabbalistic philosophy and ritual studied not only Jewish, but also early Greek, and Christian Gnostic writings, as well as the writing of a Sufi sect at Basra, the *Brethren of Sincerity*. Isaac the Blind was the leader of the influential Provençal schools of his day. Another key figure in early kabbalistic development was the 14th century Spanish scholar Abraham Abulafia of Saragossa. Said to have been of messianic proportions, Abulafia traveled the Middle East and North Africa and returned with certain yogic techniques of posture, breathing, and rhythmic prayer, and introduced them to his disciples in a new kabbalistic structure.

It is important to note that some of the most profound leaps in human consciousness took place during this period when Europe was in the last death throws of the Dark Ages. Yet despite the ignorance and intolerance that existed in Europe north of the Pyrenees Mountains, in Spain a mystical revival was taking place in a period of Arab ecumenical tolerance. While Christians and Muslims were fighting wars for the

political and spiritual control of the Middle East and Spain, Jewish intellectuals rose to positions of power and influence in the Arab empire.

This "Golden Age" of Medieval Judaism peaked in Arab occupied Spain and contributed some of the most profound Jewish mystical philosophers since the period of the Prophets in the Old Testament. Moses ben Maimon, the preeminent commentator on classical Jewish writings, Solomon ben-Gabriel, and Moses of Cordoba, the author, or more likely editor of the *Sepher Zohar* come from this period. The *Zohar*, or Book of Illumination, along with the *Sepher Yetzirah* (Book of Formation), forms the basis for all kabbalistic speculation, meditation, and ritual. Its commentaries on Biblical lore are a never ending storehouse of wisdom for students of Western mysticism. It is because of these activities in Spain, in the region of Catalonia in particular, and Provençal in Southern France, that Kabbalah grew into one of the most powerful and influential mystical philosophies in Western history.

This is also important to mystical students because it is from Arab Spain that the West gets much of its knowledge of Alchemy, and Ritual Magic, the sisters of Kabbalah. Together, these three schools formed the basis for Hermetic philosophy and practices as mentioned in the early Rosicrucian manifestoes: the *Fama Fraternitatis*, the *Confessio Fraternitatis*, and *The Chemical Wedding of Christian Rosenkreuz*. For many students of mysticism, the pilgrimage to these schools was as great and as dangerous as their forbearers had made to the temples of Egypt and

Persia. Raymond Lull, Arnold of Villanova, and the famed French mystic, alchemist, and Rosicrucian Nicolas Flamel, bookseller turned patron of cathedrals, all received their initiations into the Hermetic sciences, of which Kabbalah is a part, in Spain and brought it to the rest of Europe.

Thus, the idea of a pure unchanging stream of kabbalistic thought and technique having been handed down to Adam and existing to this day, as perpetuated by some Jewish and Hermetic schools, is mythology or foolishness. It is even suggested by some scholars that while Kabbalah has its roots in earlier Jewish mystical practices, particularly *Mercavah*, or Chariot mysticism, its ideas were entirely novel to the period of the 12th and 13th centuries. All things in nature change and adapt, kabbalah is one of these changing and evolving creations.

A perfect example of this change is the Christianization of

kabbalistic ideas by mystics who sought to preserve the early Jewish writings when they were in danger of being destroyed by the Inquisition, as well as find practical uses for what was contained within them. For this reason a kind of Christian Kabbalah (often spelled *cabala*) developed in the 15th century. It had as its goal the harmonization of Kabbalah with Christian doctrines, and found ripe justification for the Christian Doctrine of the Trinity in the Kabbalah's first three sepheroth, or "Holy Upper Trinity"

The two primary sources for "Christianized Cabala" were the writings of 'converso' Jews in Spain (sometimes called 'crypto-jews'), or Jews who converted to Catholicism, and the Platonic Academy, supported by the Medicis, in Florence.

Those writing from Jewish converts in Spain that most effected Kabbalah's development began at the end of the 13th century and lasted until the Jewish "Diaspora" from Spain in 1492. Writers such as Abner of Burgos and, Paul de Heredia secretly wrote several Christian Cabalistic works in the name of Judah ha-Nasi and other famous mystical authors. Two of their most famous texts are, *Iggeret ha-Sodot* and *Galei Rezzaya*. Other works were put out in Spain until the end of the 15th century by Jewish converts, often imitating the styles of other well known and respected works, such as the *Zohar*. However, such imitation was common and accepted in that period, and in itself is not enough to doubt the integrity of the author involved.

The Florentine schools had a greater impact than the writings of Jewish writers in Spain. While the Spanish texts were often translated and to a greater or lesser degree available, they won few if any converts from Judaism to Christianity, or from Christianity to the effectiveness of the Kabbalah. The Florentine school developed the belief that an indisputable source for the validation of Christianity, and neo-Platonic, Pythagorean, and Orphic thought was discovered in Kabbalah. Also, they believed that in Kabbalah, the long, lost secrets of the Catholic, and possibly original Christian faith, had been rediscovered. The principle founder of this Christian Cabalistic school was Giovanni Pico della Mirandola (1463-94). This young genius began his kabbalistic studies in 1486 at the age of 23, and had a large selection of kabbalistic material translated into Latin by Samuel ben Nissim who was himself a convert to Catholicism. Pico later had Raymond Moncada, known as Flavius Mithridates, translate for him as well. Among his 900 theses that he publicly displayed for debate in Rome included the statement, "no science can better convince us of the divinity of Jesus Christ than magic and the Kabbalah," thus bringing the Kabbalah to many in the Christian world for the first time.

The Church's reaction was one of fierce opposition and rejection to this and other propositions made by Pico. The

public debate Pico wanted was guaranteed. Kabbalah now became the principle discussion in the Christian intellectual world, as it was seen as an otherwise unknown Jewish esoteric doctrine that had been overlooked or lost completely. Christian Platonists in Germany, Italy, and France quickly attached themselves to Pico's school of thought. Pico's works also caused Johannes Reuchlin, the famed Christian Hebrew scholar, to undertake kabbalistic studies, publishing two books on it as a result - *De Verbo Mirifico* (On the Miracle-Working Name, 1494) and *De Arte Cabalastica* (On the Science of the Kabbalah, 1517).

Between the publishing of Reuchlin's *Verbo* and *Arte*, a number of works appeared from the pen of Paul Ricius. Ricius was himself a convert to Catholicism, as well as the physician to Emperor Maximilian, and had a reputation for being erudite. Ricius took the ideas of Pico and Reuchlin and added to them his own conclusions based upon kabbalistic and Christian sources, forming a doctrine of the "Divine Name" and its relationship to world history.

According to Ricius, all of world history could be divided into three stages based upon the names of God found in the Bible. The first period was the *natural period* where God reveals himself through the three lettered Divine Name Shaddai (The Strong). The second phase is the *Torah period*, where God reveals to Moses the Divine Name of four letters, the Tetragrammaton, or YHVH. The final period, or *period of grace and redemption*, God reveals the Tetragrammaton plus the fifth letter shin, or the letter of the Logos (Christ), spelling Yehoshua or the Cabalistic rendition of Jesus' name. Thus, the name of Jesus, or the Miraculous Name, become the pronounceable name of the previously unpronounceable YHVH. To support his argument, Ricius used medieval manuscripts in which Jesus' name was abbreviated JHS, the Jewish-kabbalistic doctrine of three world ages (Chaos, Torah, Messiah), and the similar doctrine of Joachiam of Fiore, who proposed a reign, or age, of the Father, Son, and finally, the Holy Spirit. Many of these concepts, particularly the significance of shin in the Divine Name, and the Reign of the Paraclete (Holy Spirit) would play a significant part in the development of 19th and early 20th century French (Levi and his successors) occult schools and their philosophies.

What makes the writings of Pico and Reuchlin significant, is that they placed for the first time the kabbalah in the broader cultural and theological context of Christian (principally Catholic) Europe and its intelligentsia. Their focus on "Divine Names," practical or magical kabbalah, and the synthesis of Christian doctrine with kabbalistic philosophy and speculation, became the zeitgeist of the era.

During this period, the most influential of all magical-mystical kabbalistic texts that came from the newly formed Christo-centric cabalistic tradition that was forming, was

Cornelius Agrippa of Nettesheim's De Occulta Philosophia (1531) in four volumes. This series of works on practical kabbalah was an encyclopedia of all the known occult and magical lore of the day. It is from these works, that much of the Christian world received its information regarding magical and numerological associations with kabbalah.

Other Christian thinkers sought to reconcile this lack of mastery of principle kabbalistic source materials during the 16th century by returning to the Hebrew and Latin originals. While the primary goal was to further prove the connection between Christianity and mystical Judaism, the end result was a broader intellectual understanding of Hebraic studies. Two of the most prominent figures in this movement were Cardinal Egidio da Viterbo (1465-1532) who was heavily influenced by the Zohar and Sefer ha-Temunah in his writings Scechina and "On the Hebrew Letters", and Francesco Giogio of Venice, (1460-1541) a Franciscan, the author of two large volumes on kabbalah that were read extensively at their time, De Harmonia Mundi (1525) and Problemata (1536). In both works the kabbalah was central to the themes developed, and the Zohar, for the first time, was used en masse in a work of Christian origin. Giogio's writings also elaborated extensively on Pico's theses.

Among all of these scholars, the most influential/ remembered, and closest to the original Hebrew sources was Guillaume Postel (1510-1581). Postel, a French mystic, translated into Latin the Zohar and Sefer Yetzirah before they were publicly printed in Hebrew. His translations included mystical annotations of his own theosophic philosophy as applied to kabbalah. His publications also include a Latin commentary (1548) on the mystical symbolism of the menorah, and eventually a Hebrew edition.

Throughout the 16th century Christian cabalah focused its own internal theosophical development, and not upon evangelizing among the Jewish populations of Europe. However, such a cause could be justification enough for studies that might otherwise get one arrested or killed. With the development of these increasingly Christocentric theosophical speculations, less and less time was spent with original Hebrew sources or their Latin translations. One of the few exceptions to this was Johann Albrecht Widmanstetter (1560-1557) who amassed a large collection of kabbalistic source materials for his studies.

With the writings of Jacob Boehme and Knorr von Rosenroth in 17th century Germany, Christian Cabala took a definite turn away from Hebrew source material, a turn that would last for some time to come. While Rosenroth's Kabbalah Denudata (1677-84) made much of the Zohar available to Christian readers for the first time, his essay on the Adam Kadom and its relationship to the 'primordial man Jesus' in Christian theology seemed to upstage the Zohar in many respects. The essay appearing at the end of

Denudata by the Dutch theosophical speculator, Franciscus Mercurius van Helmont, is particularly strong on this point. The essay is entitled "Adumbratio Kabbalae Christianae" and is anonymously authored.

In England the 'Cambridge Platonists,' led by Henry More and Ralph Cudworth, to make use of kabbalah for their own speculations, and found a link in van Helmont for further Christianization of cabalistic philosophy. In Germany, and later elsewhere, kabbalah had taken on a strongly 'Boehmian' character as it found a strong similarity between Jacob Boehme's writings and those of the various schools of kabbalah. While there is no historical connection between the writings (and visions) of Bohemia, this definite link would only further remove Christian Cabala from its earlier tenuous connections with Jewish Kabul. Bohemia's impact would extend into the writings of Louis-Clad de Saint-Martin, just prior to the French Revolution, thus helping to change the face of Continental mysticism and the later "French Occult Revival"

Christian Cabala almost from the start developed into what we now call the Hermetic, or Alchemical Kabbalah, for lack of better terms, which sprang out of the Hermetic schools in the Renaissance period. The goals of Hermetic philosophy were to synthesize all of humanity's previous learning, particularly the wisdom or *sophia* of the ancients, and present it in a single universal philosophy (*pansophia*). This philosophy was the synthesis of four major stands of thought and practice under the general heading of a form of mystical Christianity. These four schools were Jewish Kabbalah, Hermetic literature, neo-Platonic (Pythagorean) philosophy, and Gnosticism. In fact, the addition of alchemical symbols and motifs to Christian Cabala began as early as the 16th century. Among the chief exponents of this movement in Elizabethan England were Sir Francis Bacon, Elias Ashmole, Thomas Vaughan (1622-1666) and the Rosicrucian apologist Robert Fludd (1574-1637). On the continent, Blaise de Vigenere, Traite du Feu (1617), Heinrich Khunrath, Ampitheatrum Sapientiae Aeternae (1609) typified this kind of permanent departure from traditional Jewish literature and the formation of a completely separate system of theosophy. By the mid-18th century, this departure would be complete with the writings of F.C. Oetinger (1702-1782), the Opus Mago-Cabbalisticum (1735) by Georg von Welling, and the virtual explosion of Masonic, and psuedo-masonic, grades, degrees, rites, and orders.

The creation of Masonic and masonic-style systems was nowhere more virulent than in 18th century France. Here, like in Germany, the nobility had an almost insatiable appetite and gullibility for things mysterious and magico-mystical. While many of the rites created were for the purpose of perpetuating the true and authentic mysteries of hermeticism, either on their own or as an addition to Freemasonry through the 'High Grades' system, many were

also created to simply fill the pockets of their self-appointed Hierophant or Grand Master. The majority of these systems had little known lasting influence outside of the period, or even the rooms where their 'initiations' and 'conventicles' were held. However, one of these systems, that of Don Martinez Pasquales, was different, and its impact on Western mysticism would be felt for centuries to come.

The appearance of Martinez Pasquales upon the scene of French "Initiation" was like that of many of his contemporaries: mysterious, of unknown origin, filled with claims of supernatural contacts, and filled with Cabalistic signs and symbols. Unlike many of his contemporaries, however, Pasquales' influence would be a lasting one, and his system of magic, restoration, and angelic communications was unique. Nothing of its kind had been revealed to the world since the writings of Dr. Dee and Edward Kelly, and while definitively Christian-Cabalistic in nature, nothing equal to it has been delivered since. This is not to say that all other systems are inferior to Pasquales (or even Dee), only that such uniqueness in thought and form comes around only rarely.

Born in Grenoble, of Spanish descent, Martines Pasquales received his authority to transmit the ancient teachings from his father, who was granted a Masonic charter from Charles Stuart, "King of Scotland, Ireland, and England," dated May 20, 1738. The power and authority of this charter was transmissible upon death of the holder. As a result, Martines created a movement of distinct masonic character, open only to Master Masons, and named it: Order of Knight Mason, Elect Priests of the Universe, or Elus Cohen (Elect Priests).

While Pasquales' 'spiritual mission' officially began around 1758, he did create a masonic chapter in Montpellier four years earlier. It was a year later, in 1755, that the Elect Priests were officially rounded in Bordeaux. Paris was the site of the ventual Sovereign Tribunal in 1766, which had among its members several prominent masons of the period. Avignon, Montpellier, Metz, La Rochelle, Versailles, and Lyon were all sites of future Lodges of the Order of Elus Cohen.

What made the Elus Cohen distinct from the masonic organizations it drew its membership from, was its emphasis on ceremonial magic, or *theurgy*, for the 'Reintegration' of humanity. The Martinist doctrine of Pasquales focused around the 'Fall of Man' and its rectification. Its fundamental tenants were:

- 1) Archetypal Man, or Adorn Kadom, was emanated from God, and originally dwelt on a high spiritual plane.
- 2) Through abuse of his 'free will' Adorn Kadom 'fell'
- 3) This originally unified being shattered into the many

individual souls that now exist.

- 4) The goal of humanity is to reintegrate itself with the original archetype, thus achieving unity.

The Order of Elect Priests was divided into three principle parts, completed by the secret grade of "Reau+Croix" The first group was composed of those who went through the first three degrees of Craft Masonry, with a complementary degree following; the second group contained the 'Porch Degrees' of Cohen-Apprentice, Fellow-Cohen, and Master Cohen; the third group was the Temple Degrees of: Grand Master Elect Cohen, Grand Architect of Chevalier (Knight) d'Orient, and Grand Elu de Zorobabel.

Through rituals, often lasting up to six or more hours in length, in individual and group work, each member of the Order was given the opportunity to communicate with angelic beings, overcome demonic forces in the universe, manifest the power of God, and "Reintegrate" himself with the original Primordial Adam. The Ladder of Spiritual Entities that each member had to contact and become initiated into began with the Minor in Privation (worldly man), Reconciled Minor (one who has begun the spiritual path), the Regenerated Minor, a transition phase exists with the Elect Minor, and followed by the Superior and Major Spirits of the Celestial Hierarchy, ending with God.

While the rites and rituals of the Elus Coven are still practiced much as they were two-hundred years ago (a lodge is still active in Paris) it was through two of his disciples, who would take radically different paths, that the legacy of Pasquales would be perpetuated. Louis-Claude de Saint-Martin and Jean-Baptiste Willermoz.

Saint-Martin received his initiation into the Elus Cohen in 1786 while serving as an officer in the French garrison at Bordeaux. He was 25 at the time, and would later write, "It is to Martines Pasquales that I owe my introduction to higher truths." His appreciation of his earlier Master would serve him well, for unlike many who break from the tradition that gave them spiritual birth, Saint-Martin was entirely grateful to Pasquales despite his later philosophical disagreements.

After leaving the army in 1770 to devote himself to his esoteric research, Saint-Martin became Pasquales' personal secretary. By 1777, however, three years after the death of his Master, Saint-Martin moved away from the theurgic practices of the Elus Cohen, claiming personal lack of 'talent' for the operations, and entered into the realm of pure, abstract mysticism.

Soon afterwards, he became connected with the 'Order of Unknown Philosophers' and quickly became a teaching force within its ranks, traveling often to establish contacts,



study groups, and convey initiations throughout Europe. Claiming connection with an ancient Order, dating back to 1643 of a 'Rosicrucian character, and having Heinrich Khunrath, Alexander Sethon, Sendivogius, and Boehme among its ranks, the Society of Unknown Philosophers also linked itself to "Les Freres d Orient" created in Constantinople in 1090. The teachings of this society were conveyed from teacher to disciple and the their principle unifying form was the distinction of receiving "The Initiation, which gave them the right to be known as "Unknown Superiors., or "Superieurs Inconnus- or S.I. as it is written. Saint-Martin's writings, under the pseudonym "The Unknown Philosopher,,. made him quite in demand among European aristocracy. Being of aristocratic blood himself, it is often considered a miracle that he not only kept his head during the 'Reign of Terror' but also managed to continue his work relatively unimpeded.

Jean-Baptiste Willermoz however continued the teachings of the Elus Cohen, and even took them into the masonic Order of Strict Observance, an order claiming direct Knights Templar descendency. It was through these two principle forces, the teachings of Willermoz through the Strict Observance, and Saint-Martin through his 'free Initiation' that French esotericism in particular, and European esotericism in general, continued until the period known as the "European Occult Revival".

While the "European Occult Revival" has its origins in France with the writings of Eliphas Levi, it is not until the 1880's that it becomes a full fledged social force, similar to today's "New Age Movement", complete with celebrities, art galleries, mystical compositions of all sorts, the usual ego's, personality failings, and just plain old gossip.

The principle character in all of this was a young medical student by the name of Gerard Encausse, better known by his pseudonym, "Papus" after the Egyptian genii of the healing arts. With Augustine Chaboseau, Stanislas de Guaita, Sedir (Yvon Leloup), Charles Bartlet, Josepin Peladan, and virtually all of the moving forces in French occultism the Martinist Order was rounded, by Papus, to perpetuate the ideas and teachings of Saint-Martin, Martinez Pasquales, in a new kabbalistic framework, complete with seven degrees, which were later reduced to three. Soon afterwards the "Kabbalistic Order of the Rosy+Cross" was created, and after several years, and a few 'spitting matches', schisms among the rounding members created about a dozen off-shoots, most of which continue to this day in some form.

Yet, by 1914, what petty rivalry, egotism, and 'oneupmanship', had failed to do to European mysticism and magical movements, world war would accomplish. The world wide networks of initiates and lodges that were created out of this period, along with similar movements in

England (the Hermetic Order of the Golden Dawn, and the Societas Rosicruciana in particular), Russia, and Germany (as well as the United States) were virtually eliminated by two world wars and the totalitarian governments that controlled most of Europe by the 1920' and 1930's.

Unfortunately, not all of the 'hermetic' 'kabbalistic' or 'occult' movements that were born at the turn of the century gave fruit to humanitarian offspring. In Germany and Austria the Ariosophist movements gave not only 'spiritual' inspiration, but also men and material support to what became the National Socialist German Workers Party (NSDAP), or the Nazi movement. The Germanen Ordnung (Order), the Thule Society, and other less well known groups, gave ideological justification for the racist, militant, and nationalistic beliefs of the German Right Wing. In 1934 Hitler declared, "We shall form an Order, the Brotherhood of the Templars around the Holy Grail of pure blood." The Grand Master of this Order was Heinrich Hiramlet, its knights the Officer Corps of the SS, and the Castle at Wewlsburg, with its Round Table, its spiritual center.

While promoting its own form of occult madness, the Nazis systematically shut down all forms of occult and esoteric activity. Psychics, astrologers, faith healers, writers, publishers, and simply well known individuals in the field, were rounded up under Berlin's "Witchcraft Laws" of 1934, all in a single night. Publishing houses were shut down, books burned or carted off to *Ahnenerbe* (Racial Ancestry Department) research libraries, people imprisoned or forced into 'domestic exile', and that was just the beginning. Several waves of round ups would continue throughout the war, particularly as the tide turned against German victory.

Viewed as part of the "Jewish Conspiracy" Freemasonry, Rosicrucianism, Martinism, and other kabalistic-hermetic or esoteric organizations were the special target of these crackdowns, led by "Einsatzgruppen Rosenberg" and the Ahnenerbe. Not since the Inquisition had Western esoteric, initiatic, and cabbalistic-hermetic groups especially, been so violently suppressed with such singleness of purpose.

The role call of martyrs included many of the leaders of the most prominent magical and mystical movements of the period. The egotistical rivalries that separated them and kept the Light from unifying, was skillfully and brutally used against them by Darkness. The faggots burned again in Europe, this time with smoke stacks.

Despite its opponents, and inspite of some of its most ardent supporters, kabbalah and hermeticism, the life blood of Western esotericism, continues to survive and thrive. Never before has so much material, books, publications, organizations, and students existed so openly and freely. As we head toward the millennium, and pray for the "Reign of the Paraclete," let's look back on history and learn its lessons.

(Continued on Page XI)

*(Over the past several years I have witnessed all types of drama and glamour concerning the path of Return, especial related to laboratory alchemy. I was planing to write an article about glamour in this issue of the Stone. In the fall issue of THE INNER JOURNEY my dear friend Joseph Nolen wrote a wonderful article on the very subject. It would have been a difficult task to do better, so we have been given permission to reprint this article in the STONE.*

*Joseph Nolen is the editor and publisher of the Inner Journey, and has been a student of the Path of Return for over 50 years. Those interested in a subscription to the Inner Journey can send a check for \$15.00 To:*

**The Inner Journey, PO Box 1755,  
Laguna Beach, CA. 92651**

*I would like to offer my thanks to Joseph for his offering of this article. Ora et Labora, Kevin Townley)*

# Glamour

by Joseph Nolan

*Dictionary: GLAMOUR - romantic, exciting, often illusory attractiveness; alluring or fascinating personal attraction.*

Glamour is an addictive sleeper for those on the Path as it tends to keep them locked into identification with the personality and pursuit of its goals. The personality, in its illusion of aloneness, seeks any event, achievement, possession or appearance that will give it a feeling of elevation and superiority over others. Its feeling of self-worth comes not from within but from the opinion of others. Glamour feeds the personality's desire for envy and admiration and is also a billion dollar sales incentive. "Just imagine what the neighbors will say when they see the new Glamourmobile in your driveway!" The principle of conspicuous consumption is based on glamour. "What's the fun of having it if you can't flaunt it?"

Alice Bailey of the Arcane School spoke of glamour as a world problem, but it is especially so for the esoteric student in the process of being loosened from the bonds of personality identification. One might not think so but the Path is pot-holed with glamorous temptations. Personality will use anything to elevate itself and the Path is not exempt from its efforts, based on delusion. Some examples:

1. The glamour of initiation. Suddenly you are ten feet above the uninitiated. "My spirituality has finally been recognized. How can I let people know without actually telling them? Surely they will see it when they look at me."
2. The glamour of position. The illusion of the importance of being the one chosen to lead.
3. The glamour of aspiration. Can create a tendency to self-satisfaction and resting on one's laurels.
4. The glamour of responsibility. "How dependable and mature I am. Please load me up with those chores others do not want."
5. The glamour of devotion. Promotes the fanaticism of the "only way'."

6. The glamour of knowledge. Tends to produce a superior righteousness of opinion.

7. The glamour of being an oracle. Karmic danger here. Creates dependency in others.

8. The glamour of service. This and all the others can promote a sense of spiritual pride - a sense of being a bit superior to others in this area and all are separative.

These are only a few of the glammers on the Path. There are more. It is also important to realize that by no means all aspirants experience ego inflation through the glammers of the Path. The secular life, however, is literally wall to wall with glammers - occupation, wealth, possessions, physical beauty, travel, clothing, clubs, schools, cars, sports, churches, charities, the neighborhood one lives in - all are magnetically producing motion toward these goals that are empty of true satisfaction. But they actually serve the search for that which is real.

After being influenced by glamour over lifetimes, one does not suddenly abandon the pursuit of personality goals overnight upon entering the Path of Return. The disillusionments have to grow to the point of discomfort that turns one inward in the search for the cause. Identification with the personality is always revealed as the cause and thus is joined a most important phase in the unfolding of greater conscious awareness

When one is sincerely intent on becoming aware of one's motivations, subconsciousness then responds by drawing our attention to subtle instances of negativity that we would ordinarily not be aware of. Without the help of subconsciousness, greater awareness cannot be realized. This is the true use of subconsciousness on the Path.

Curse not the potholes of glamour on the Path for they pave the way to the realization of Unity.



# A Homemade Retort for Mercury Distillation

by Henry Hintz

The LPN recommends using glass equipment for the distilling of metallic mercury. While this may be the ideal method to follow it is quite costly and can cause some other difficulties. The following drawing illustrates an alternative retort which can be used and has served me well for many years.

This retort is made up almost entirely of common galvanized pipe fittings that are cheap and readily available at any hardware store. The only odd pieces are items 5 and 6. 5 is a 1/2 inch male pipe thread to 1/2 inch O.D. tubing connector in stainless steel. 6 is 1/2 inch O.D. stainless steel tubing. These two items are typically available from supply houses that cater to the industrial instrumentation business. One example would be Moody Price. While you are buying these parts, also buy a tubing bender to make the bend needed in the tubing.

There are many different grades of stainless steel tubing available. These different alloys are there to suit the tubing to the type of process that they are used in. In my retort, I use 316 stainless but this is not absolutely necessary. The stainless minimizes the reaction of the tubing with the mercury while it is distilling over.

The common pipe fittings are galvanized, which means that they have a coating of zinc on them to protect the steel from corrosion. Before using these fittings for the first time, I super-heat them to burn off the zinc because the zinc would easily unite to the mercury during distillation.

I find that this retort does an excellent job. It can be hung from tie wire instead of using some type of stand. This is very convenient in itself because of its flexibility when setting up.

It is also reusable. It can be unscrewed so that you can get to the residue with ease. Being made of steel, a small Bunsen burner flame is all that is required to volatize the mercury.

To conserve the heat, I use a form of rock wool that I wrap around the body of the retort and cover the tubing where it is bent. Some tie-wire serves well to hold the rock wool in place. It is also good to use some Nickel Ease thread lubricant on the nipple threads to keep them from seizing. This lubricant has a high temperature rating but others can be substituted if they have the right temperature rating.

For a receiver, I use an empty bottle of about a quart capacity. I fill the bottle with about 8 ounces of water and place the

1/2 inch tubing into the mouth of the bottle so that it almost touches the water. While I do not seal the connection of the bottle and tubing, it may be done if you choose to with a little ingenuity.

I have had great success with this retort and recommend it. Philaethes says to use a chalybeate retort so I see no reason to fight with glass when this option is available. The retort as described suits my work which is on 1 pound of mercury at a time. It can be resized with little difficulty to work with larger or smaller amounts.

If this article receives favorable reviews I will share more information that may be helpful to others on the Animated Mercury path. May God bless you and your work!



## KEY:

1. 1 1/2" Pipe Cap
2. 1 1/2" Close Nipple
3. 1 1/2" to 1" Bell Reducer
4. 1" to 1/2" Reducer
5. 1/2" S.S. Tubing Connector
6. 1/2" S.S. Tubing

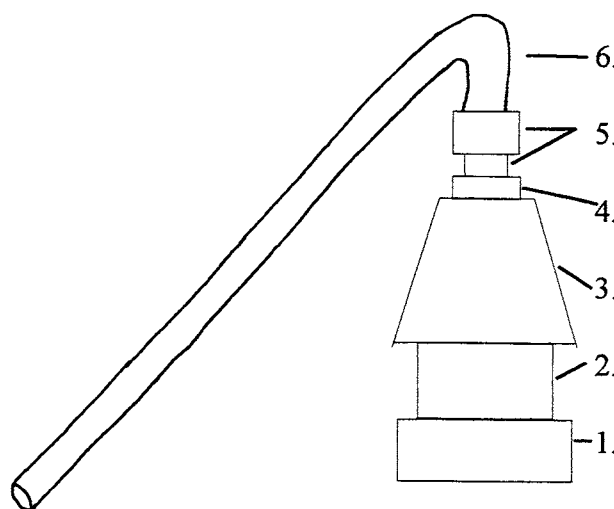

# Force Fields, Fulcanelli, and Flamel

by Russ House

There is something mysterious that happens to books and manuscripts when they are not being read. It is difficult to say precisely how it happens, but the words are seemingly being rearranged on the page when the text is apparently idle on the shelf.

It is true, of course, that a document studied at one time has a different message, or a different level of importance when read at a later date. This most recently occurred when I picked up *The Fulcanelli Phenomenon* by Kenneth Rayner Johnson. It is not one of my favorite texts, so I have not studied it particularly well.

As I flipped through the book, I came upon some selections that were taken from the best-selling *The Morning of the Magicians* by Pauwels and Bergier, a book that I had read when beginning high school. I later came to regard much of Bergier's writing as somewhat less than scholarly, but good entertainment. Johnson quoted from Bergier's account of a visit he received from a mysterious alchemist, whom he concluded to be Fulcanelli. Although this meeting was several years after Fulcanelli's disappearance, Bergier was convinced regarding the stranger's identity.

One afternoon in the summer of 1937, Bergier was visited by the stranger, in the Parisian laboratory where he was working. Bergier was working on projects with Andre Helbronner, a brilliant physicist, researching nuclear physics. Without introduction, the visitor identified himself as an alchemist, and indicated that Helbronner's experiments were on the brink of liberating nuclear energy, which could potentially be disastrous for the planet. His revelation was accompanied by certain technical information for Helbronner, which would, I think, have convinced him of the knowledge of the alchemist, and perhaps have shortened his research. The alleged Fulcanelli indicated that his warnings were out of a sense of duty, of ethics, and that he doubted that his cautions would be heeded.

Bergier asked his visitor for an explanation of alchemy.

*"You are asking me to summarize in four minutes four thousand years of philosophy and my whole life's work. Furthermore, you are asking me to translate into plain words concepts for which such a language is not intended. All the same, I can say this: you will not be unaware that in present-day official science the part played by the observer becomes more and more important. Relativity, the principle of indeterminacy, demonstrate the extent to which the observer today intervenes in all these phenomena. The secret*

*of alchemy is this: there is a way of manipulating matter and energy so as to create what modern science calls a force-field. This force-field acts upon the observer and puts him in a privileged position in relation to the universe. From this privileged position, he has access to the realities which are normally concealed from us by time and space, matter and energy. This is what we call the Great Work."*

What then of the Philosophers Stone? asked Bergier.

*"The vital thing is not the transmutation of metals. but that of the experimenter himself. It is an ancient secret that a few people rediscover each century."* [Italics mine]

I have read these words more than once over the years, but without much effect. Relatively recently certain experiences have made these statements rather persuasive. I can think of many reasons not to speak about the details of the experiment that was a stimulus to this change in my thinking, and yet I think that there is a certain obligation to state facts that may be of benefit to others working along similar lines.

The idea that alchemy, like operative qabala, is a means of creating a condition which permits access to different levels of energy has been stated by Jean Dubuis at nearly every lecture. Alchemy has benefits in that self-deception is less likely because of the laboratory setting. (I will say that there are careful qabalists and sloppy alchemists, but I take the statement to be relatively true).

As an idea it was attractive enough, and interesting enough. I did not make the connection between this idea and the experience which I had, until after some months of reflection. It is not necessary to say what the experience was, but the setting should be revealed, and that setting has to do with the Flamel path, so called.

This path makes use of the metallic life of antimony to animate metallic mercury. In the course of the process, one makes amalgams which are distilled. A friend in France knowing that I was 'flying eagles' or making these distillations, suggested that I 'pay attention' to how I felt during the distillations. I did so, in spite of the heat, the work, and periods of intense concentration that the distillations required. We compared our experiences at some time, and I recall nothing about the exchange, except that it was not of any real significance to me.

In the fall of 1993, during a seminar at St. Charles, IL, a

distillation of an amalgam was demonstrated out of doors, using an electrically heated distilling apparatus. For reasons of safety, the large group observing the process was seated at some distance from the equipment.

At that time, I had an experience which was both physical and 'subtle' which convinced me that the distillation of amalgams can create a force field of significant proportions. Further, I was satisfied by certain facts of the experiment that there was no self-delusion nor expectation of an experience on my part, and that the force field induces chemical changes within the operator. "The secret of alchemy is this: there is a way of manipulating matter and energy so as to create what modern science calls a force-field... The vital thing is not the transmutation of metals, but that of the experimenter himself."

I could enter into speculation about the exact causes of the field and what is taking place during the distillation, but that only leads to further speculation, and not to real knowledge. A friend of mine has had similar experiences in work on the vegetable kingdom. It is my hope that sharing the experience will encourage others to discuss the circumstances of changes in themselves that have come from their work.

As a caution, I do not suggest that anyone enter into the 'Flamel' work without taking all of the precautions for safety that are necessary. Mercury is a toxic material which deserves respect and tremendous care to avoid poisoning the experimenter and others. Further, there is evidence that experiments in the vegetable kingdom, which is much more forgiving, can induce similar results.



## Kabbalah and the Hermetic Tradition,

*Continued from page VII*

With Europe and Asia looking more like 1914 than 1994, let our hearts unite in active prayer and meditation to turn the world toward the Source of Light we all so earnestly seek when we pray "Thy Kingdom come..." after all, that is what kabbalah is all about.

### Bibliography

Anonymous. Five Christian Principles. Public Publications, 1984. Forward by Sarah Ibitson.

Epstein, Perle. Kabbalah - The Way of the Jewish Mystic. Shambhala, Boston, 1988.

Goodrick-Clarke, Nicholas. The Occult Roots of Nazism. The Aquarian Press, Wellingsborough, Northamptonshire, 1985.

Howe, Ellic. Astrology and the Third Reich. The Aquarian Press, Wellingsborough, Northamptonshire, 1984.

King, Christine Elizabeth. "The Nazi State and the New Religions". Studies in Religions and Society. vol. 4. The Edwin Mellen Press, New York, 1982.

Knight, Gareth. Magic and the Western Mind. Llewellyn Publications, St. Paul, MN., 1991.

McIntosh, Christopher. Eliphas Levi and the French Occult Revival. Weisser, NY., 1974.

The Rosicrucians - The History and Mythology of an Occult Order. Crucible, Wellingsborough, Northamptonshire, 1987.

Scholem, Gershom. Kabbalah. Meridian, New York, 1978.

Stavish, Mark. "A Rosicrucian Approach to the Kabbalah". Lecture delivered to Johannes Kelpius Lodge, AMORC Allston/Boston, Mass., 'Reunion Day' June, 1992.

### Periodicals

"The F.U.D.O.S.I. - An International Journal of the Ancient and Honorable Esoteric Orders" Vol. 1, No. 1, November 1946. Brussels, Belgium.

"Now It Can Be Told" part 1 through 8, Ralph M. Lewis, F.R.C., "Rosicrucian Digest", San Jose, Calif., Oct. 1946 though May 1947.



# Freemasonry: An Introduction

by Tim Scott

*(Important Disclaimer! I am indeed a member of a Masonic Lodge, but everything I write here is personal opinion or the facts as best I have been able to determine them. They are in no sense "official.")*

## \* Is Masonry Irrelevant? \*

Wow—Masons. What a concept... What could be less cool, less relevant and more boring than a half-baked social club for a bunch of old geezers? You definitely won't read about them in *Wired*, the *Utne Reader*, or *Mondo 2000*, or see a special about them on MTV. And horror of horrors, on top of all that it's also a sexist organization, as women are not admitted to membership. But yet this group was one of the most influential worldwide for many decades. It was almost a given that the powerful, the eminent and the famous all belonged to it. But those days are long past...so what's the story here?

## \* My personal introduction to Masonry \*

I have all my life been interested in old and obscure things, the occult, magic, secret societies and hidden lore. I knew nothing of the Freemasons, since none of my relatives had been members, nor anyone I'd ever met, as far as I knew. As far as the magical/occult/secret societies I know of: most of them, frankly, consisted of people I would charitably characterize as "confused", looking for some kind of power that their group implied would be theirs at some point in the future. Without meaning to attack them across the board, suffice it to say that many of them claimed to be able to initiate their followers into the deepest mysteries of the universe, obtain for them great wealth, troupes of adoring members of the opposite sex and so on. And yet, once you investigated the group a little more closely, you found that the adherents were (much more often than not) unhappy, confused, deluded and especially downright impoverished. If there was any material success in the group, it usually devolved to the benefit of a few people at the top of the hierarchy. But this was even rare, as of even the founders and/or leaders of the group did not enjoy the power, wealth and success advertised. After many, many discoveries of this nature, it was easy for me to get cynical.

(I don't deny that there are sincere organizations, and perhaps even some that do much good. In fact, there might

be an organization out there somewhere that does deliver the goods, so to speak. If so, it's not hard to see why it would not be interested in broadcasting its existence.)

Compared with the extravagant claims of other societies, Masonry promises very little. In fact, it doesn't really promise anything magical at all. This makes it sort of hard to explain to people who ask what it's all about. (Now that I am able to answer that question partially intelligently, nobody's asking me anymore!) It simply identifies itself as a fraternity which teaches a system of morality in a symbolic manner. On the surface, nothing could appear more boring. I mean, good Lord, except for religious fanatics, who wants to join a group that's interested in morality?? And worse, all the members of like mind: that seems like a recipe for a militant bunch of zombies bent on imposing their beliefs upon the world.

And yet the reality of Masonry has nothing to do with that image. In fact, Masons are some of the most fascinating people around (at least to me). And their morality is not of the *Carrie Nation* flavor; rather it is an internal realization that you cannot change the world, but you can try to change yourself. So it seems that Masons begin modestly: trying to be just a little friendlier, a little more honest, and a little more committed than the average person.

The change it wrought in me is not huge. But I have been in situations where perhaps it would have been easy to be just a tiny bit unethical, unpleasant or rude, and a vague remembrance of the Masonic obligations forms. It's not even a conscious "gee, I'm a Mason; I'd better behave like one in this situation." My behavior might change slightly at that point, imperceptibly to others and really even not that consciously to myself. It's not the internal voice of the disciplinarian with the ruler across the knuckles, or a religious image with a pointing finger and accusations of guilt. Just a "still, small voice" suggesting another way.

Now let me hasten to say that I am not attempting to project a pious impression. In fact, I sometimes feel guilty I can't participate in Masonic activities more than I do. I still have a long way to go, but the way is easier when I think of the friendly faces of my friends and Brothers in the Craft.

Alchemists, in the course of their studies, search in realms far from the common run, and I believe it is good to make contact with energetic currents that are of much higher quality (a "higher frequency" as it were). Part of my motivation for joining the Masons, was to put me in touch with

these energies. I really have not discussed esoteric matters with any other Masons, save one other member of my Lodge, since most of them are normal working men with jobs and families. But that's not really the important thing: since Masonry is a huge fraternity, and if there is a group working in an area I want to know about, I'm sure I could get in touch with them with a little effort; however, now is not the time.

I was going through my archives recently, and came across a brief tract on Freemasonry which I'd like to share with you. It seems the author took as his starting point the frequent but incorrect assertion that Masonry is a "secret society." It comes from the Victorian (Australia) Mason, Summer 1990:

"Masonry is not a secret society. Everybody knows that the Masonic fraternity exists and no effort is made to hide the fact. It is only the wisdom of Masonry which is hidden, not because it is subtle, but because it is simple. Its secret is profound; not obscure.

"In the quiet of the lodge, in an air of reverence and friendship, it teaches us the truth that makes us men, and upon which faith and character must rest.

"What is secret in Freemasonry? The method of its teaching, the atmosphere it creates, the spirit in our hearts and the ties it weaves between men. The secret of Masonry, like the secret of life, can only be known by those who seek it. It cannot be uttered, it can only be felt and acted. For that reason no one need be alarmed about my book written to expose Masonry. It is utterly harmless.

"The real secrets of Freemasonry cannot be learned by prying eyes or by curious inquiry. The secrets of Masonry can be known only by those who are ready and worthy to receive it. Only a pure heart and honest mind can know it. If Masonry uses the illusion of secrecy, it is because it knows that it is the nature of man to seek what is hidden. We are seekers after truth and God has so made us that we cannot find the truth alone, but only in the love and service of our fellow man. Here is the real secret and to learn it is to have the key to the meaning and joy of life."

This eloquent little essay really helps give a feeling for the purpose of this organization. But it really never really says what Masonry "is." Let's look at the fraternity from a different perspective.

### \* What is Freemasonry? \*

There are a number of ways to answer this question, but from a simple factual point of view, it's a fraternal organization for men who profess a belief in brotherly love, relief and truth. Although it encourages community involvement and charity, and has a sterling history of these

works, there is no specific charitable agenda.

Another definition I heard: Freemasonry takes good men and makes them better. Given that bare outline, in practice in my experience, it seems to attract men of a special type that's hard to define. Many men join and drift away, due to lack of interest, stimulation, or the exigencies of life, work and family. But active Masons tend to be princes among men. It seems that membership in this venerable fraternity generates a kind of continual consciousness that causes them to occasionally modify their actions to be more fair, generous or friendlier.

### \* Enemies and friends of Masonry \*

One way to examine the fraternity is to look at its enemies and friends over the years. The Catholic Church issued a prohibition on its members become Freemasons, violators could be punished by excommunication. This may sound quaint in our modern times, but this was deadly serious not too many hundreds of years ago in Catholic countries. However, the Church also saw the value in such an organization, and so created one of its own, the Knights of Columbus. This ban was lifted some years ago, but to this day many Catholics think they cannot join the Masons. Closer to our time, and more seriously, the NSDAP (Nazi Party) of late-1930's Germany totally outlawed all Freemasonry, as did Stalin in the early U.S.S.R. In Russia and all over Eastern Europe, Masonic lodges are being reactivated after decades of proscription.

Who are friends of the Masons? Until just the last couple decades, most influential political and business leaders in the free world were Masons. Many U.S. Presidents were Masons, but since Truman (an active member who was also Grand Master of Masons in Missouri) I think it was more formal than anything. The last U.S. President to be a Mason was Gerald Ford, which I think speaks more eloquently of the fraternity's decline in the U.S. of late than anything else.

Masonry sounds like a religion, but it is emphatically not. To confuse the issue, though, they insist that atheists are not eligible to join. Why is this? The founders of the "Craft" (as it is often called) seemed to understand that politics and religion are among the most divisive concepts in mankind. Thus discussion of those matters is prohibited in the Lodge Room. Yet they also realize that moral codes are difficult to create without some reference to something "Higher" than humans.

Masonry is no longer the social force in modern society that it used to be—even 50 years ago. The average age of members is increasing, as membership declines.

As a digression, I find it amusing that, although women have agitated and sued to be admitted into formerly all-male



academic and social institutions, no such suits have been brought forward against Masonry. The reality is that, in my opinion, those who wanted into the exclusive clubs and organizations wanted access to power, and perhaps making a social statement along the way. But Masonry no longer is a locus of Power. For my part, I wouldn't have it any other way. This is heretical among some of the leadership in the Craft.

Many Masons, and Masonic leadership, are wringing their hands about the decline in the number of Masons. But what is the alternative? To vitiate or dilute its teachings? To lower the standards of admittance? Certainly, it should not cause harm to at least be a little more public about the Craft. Even as venerable and august an institution as the Roman Catholic Church has made radical changes (even now, the church of my childhood now has "female altar servers." Heresy!) But in my opinion, the standards of Masonry should not be altered. Are Masons perfect? Not by a long shot. But I have found the following to be true: When you meet a stranger, you are normally on your guard until he proves himself to be trustworthy or a friend. If, however, I meet a fellow Mason, however, I automatically feel towards him like a friend until, or if, he should prove himself to not be worthy. But you know, I can honestly say I have hardly ever met a Mason I didn't like, and I have met a God's plenty.

As a world-wide organization, it is also attractive for the person who travels extensively, as I know from first-hand experience how welcome we make all visiting Brothers in our Lodge.

**\* I'm interested in information about Masonry, but don't want to join just now \***

There are an enormous amount of books out there on Masonry. Unfortunately some of the most popular are frothing pot-boilers by hack authors trying to pin the Masons to some global conspiracy. This is pitiful, since it is so far from the truth and the spirit of Masonry. But here are some books that I can recommend:

Very highly recommended is "Born in Blood" by John J. Robinson, a very readable yet impeccably scholarly look at the possible roots of the Craft. As far as its current expression goes, Allan Roberts "The Craft and Its Symbols", though horrendously proofread, is a book with good heart and full of good information. One of the standards of Masonic scholarship is "Freemason's Guide and Compendium" by Bernard R. Jones. If Jones doesn't know the answer, possibly no one does! 604 pages chock full of information. Write to the Southern California Research Lodge, P. O. Box 6587, Buena Park, CA 90622 for a current list of Masonic books.

**Less than 50 copies left!**

*"In the study of Qabalah there is no more important glyph than the Cube of Space..."*

Paul Foster Case

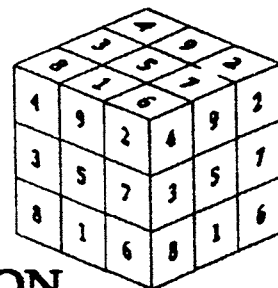
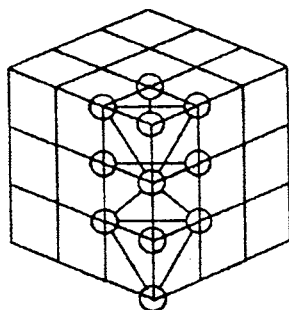

**THE CUBE OF SPACE:  
THE CONTAINER OF CREATION**

a book by Kevin Townley

Topics include:

- \* Generation of the Cube of Space through geometry.
- \* The Magic Square of Saturn.
- \* Relationship of the Cube to the Tree of Life.

- \* Placement of the Tarot (Minor Arcana) on the points of the Cube.
- \* The Cube's relationship to the Macro and Microcosm.
- \* The Cube of Space in the Four Worlds.

To order send \$45.00 plus \$3.00 for postage to  
Archive Press, Box 11218, Boulder, Colorado 80301.

**"As Above, So Below"**

**When you understand the process of Divine Creation on the macrocosmic level, you can apply those same principles on a personal (microcosmic) level!**

400 Titles

## Rare Book Reprints

Alchemy Ancient Wisdom Astronomy Baconian Eastern Thought Egyptology Esoteric  
 Freemasonry Gnosticism Hermetic Kabalah Metaphysical Mystery Schools Mystical  
 Mythology Occult Philosophy Psychology Pyramids Religions Rosicrucian  
 Science Spiritual Symbolism Tarot Theosophy and many more!

✓ Perfect Bound Paperback Reprints ✓ Acid-free paper for long life ✓ Most books with title and author on spines ✓ New titles published weekly  
 Trade discounts ✓ Visa and Mastercard accepted ✓ Phone Orders ✓ Fast Service ✓ Full Catalog with complete descriptions available

**Kessinger Publishing, P.O. Box 160-LPN, Kila, MT 59920 (406) 756-0167 Fax (406) 257-5051**

All books must be prepaid in US funds. Shipping and Handling Charges: \$4.50 for the first book, and .50 for each additional book. Foreign orders multiply total by 15% for surface or 45% for air mail.

- ADIRAMLED, *Art of Alchemy or the Generation of Gold*, 73 pages, ISBN 1-56459-319-3, \$12.95  
 ALBERTUS, FRATER, *Golden Manuscripts*, 160 pages, ISBN 1-56459-303-7, \$16.95  
 ANONYMOUS, *Compendium of Alchemical Processes*, 173 pages, ISBN 1-56459-344-4, \$16.95  
 ANONYMOUS, *Hermetic Triumph and the Ancient War of the Knights (1740)*, 220 pages, 1-56459-280-4, \$24.95  
 ANONYMOUS, *Lives of the Alchemistical Philosophers*, 400 pages, ISBN 1-56459-352-5, \$27.00  
 ASHMOLE, ELIAS, *Theatrum Chemicum Britannicum*, 633 pages, ISBN 0-922802-890, \$32.50  
 BEGLEY, WALTER, *Biblia Anagramatica*, 212 pages, ISBN 1-56459-016-X, \$9.95  
 BEGLEY, WALTER, *Biblia Cabalistica*, 158 pages, ISBN 1-56459-017-8, \$9.95  
 BOYLE, ROBERT, *Sceptical Chymist*, 452 pages, ISBN 0-922802-90-4, \$36.00  
 CHAMBERS, *Alchemy and the Alchemists*, 64 pages, ISBN 1-56459-005-4, \$9.95  
 COCKREN, A., *Alchemy Rediscovered and Restored*, 158 pages, ISBN 1-56459-148-4, \$17.95  
 ENCYCLOPEDIA BRITANNIA (1771), *Eighteenth Century Chemistry as it Relates to Alchemy*, 173 pages, ISBN 1-56459-304-5, \$17.95  
 FERGUSON, JOHN, *Bibliotheca Chemica*, 1085 pages, ISBN 1-56459-001-1, \$75.00  
 FIGULUS, BENEDICTUS, *A Golden and Blessed Casket of Nature's Marvels*, 391 pages, ISBN 1-56459-180-8, \$19.95  
 GARSTEN, E.J., *Secret Fire*, 120 pages, ISBN 0-922802-20-3, \$17.95  
 HAMILTON-JONES, J. W., *Bacstrom's Alchemical Anthology*, 152 pages, ISBN 1-56459-154-9, \$17.95  
 MUIR, M.M. PATTISON, *Story of Alchemy*, 208 pages, ISBN 1-56459-019-4, \$18.95  
 PARACELUSUS, THEOPHRASTUS, *Archidoxes of Magic*, 160 pages, ISBN 1-56459-171-9, \$17.95  
 PETRUS OF FERRARA BONUS, *New Pearl of Great Price*, 441 pages, ISBN 1-56459-142-5, \$29.95  
 PHILALETHES, EIRENAEUS, *Collectanea Chemica*, 160 pages, ISBN 0-922802-81-5, \$16.95  
 RALEIGH, A.S., *Science of Alchemy*, 172 pages, ISBN 1-56459-007-0, \$16.95  
 RALEIGH, A.S., *Speculative Art of Alchemy*, 191 pages, ISBN 1-56459-006-2, \$16.95  
 RALEIGH, DR. A. S., *Hermetic Fundamentals Revealed*, 127 pages, ISBN 1-56459-370-3, \$14.95  
 READ, JOHN, *Alchemist in Life, Literature, and Art*, 120 pages, ISBN 1-56459-210-3, \$17.95  
 READ, JOHN, *Prelude to Chemistry*, 328 pages, ISBN 1-56459-015-1, \$24.95  
 READ, JOHN, *Through Alchemy to Chemistry*, 206 pages, ISBN 1-56459-013-5, \$19.95  
 REDGROVE, H. STANLEY, *Alchemy Ancient and Modern*, 141 pages, ISBN 1-56459-143-3, \$17.95  
 REGARDIE, ISRAEL, *Philosopher's Stone*, 204 pages, 1-56459-282-0, \$17.95  
 RIPLEY, *Compound of Alchemy*, 90 pages, ISBN 1-56459-077-1, \$12.00  
 RULANDUS, MARTINUS, *Lexicon of Alchemy*, 466 pages, ISBN 0-922802-92-3, \$30.00  
 STOLTZIUS VON STOLTZENBERT, DANIEL, *Little Mystic-Magic Picture Book*, 231 pages, ISBN 1-56459-027-5, \$15.95  
 TAYLOR, F. SHERWOOD, *Alchemists, Founders of Modern Chemistry*, 246 pages, ISBN 1-56459-002-X, \$24.95  
 VALENTINUS, BASILUS, *Triumphal Chariot of Antimony*, 205 pages, ISBN 1-56459-021-6, \$17.95  
 WAITE, ARTHUR EDWARD, *Alchemical Writings of Edward Kelly*, 220 pages, ISBN 1-56459-166-2, \$19.95  
 WAITE, ARTHUR EDWARD, *Hermetic and Alchemical Writings of Paracelsus*, 800 pages, ISBN 0-922802-1-81, \$37.95  
 WAITE, ARTHUR EDWARD, *Hermetic Museum Restored*, 700 pages, 1-56459-284-7, \$39.95  
 WAITE, ARTHUR EDWARD, *Secret Tradition in Alchemy*, 413 pages, ISBN 0-922802-83-1, \$33.00  
 WAITE, ARTHUR EDWARD, *Three Famous Alchemists*, 186 pages, ISBN 0-922820-84-X, \$16.95  
 WAITE, ARTHUR EDWARD, *Turba Philosophorum*, 211 pages, ISBN 0-922802-99-8, \$14.50

*He's back!*  
 (THE LAST GREAT ALCHEMIST IN PRINT)

# ALCHEMICAL WORKS: Eirenæus Philalethes Compiled

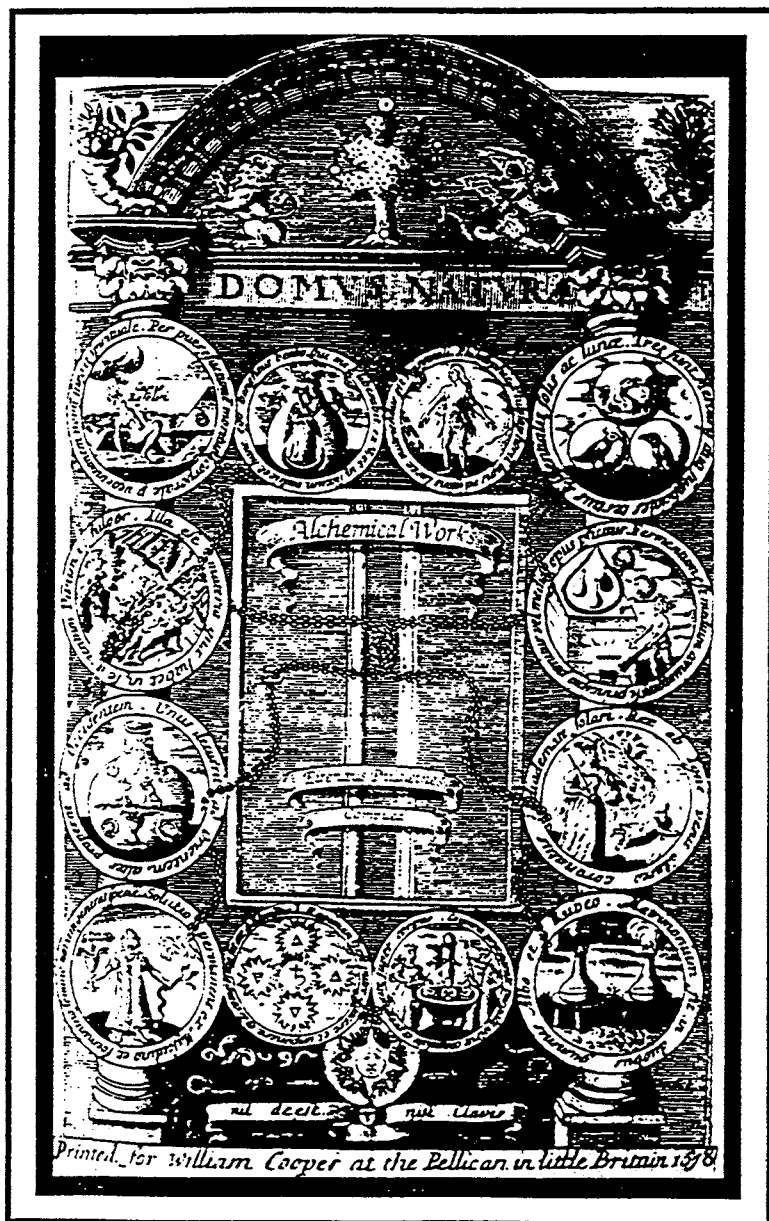

hard cover 592 pages indexed a.f.p. ISBN 0-9640067-0-7 \$60.00

\$65.00 U.S. Postage paid to:

**LPN-USA**

Box 11218

Boulder, CO. 80301

Eirenæus Philalethes, mysterious alchemical adept of the seventeenth century has elicited intrigue, study, and controversy for historians, littérateurs, and scientists since these works were published beginning in the mid-1600's.

This volume is unique. It is the only to contain all Philalethes' works currently available in English, and it is indexed.

Original format has been carefully preserved throughout, offering readers access to complete, authentic, and legible text and content for their enjoyment and studies, without having to resort to the microfilm copies previously available to most readers as the only source for much of the text contained within.

The practice of alchemy has been perennial for all of written history, woven through one civilization and into the next, often tying them together. It is a science, a philosophy, a mystery, and a quest. The very word connotes a magic transcending our limited beliefs about the laws of nature. It was used as a tool of charlatans, who did much through their deceit to destroy the reputation of the science. Much more often it has been a field of study for great minds. C. J. Jung spent his last twenty years illustrating its value in framing the workings of the subconscious through alchemy's rich use of metaphor. Sir Isaac Newton poured over Philalethes' tracts, finally preparing what he thought to be Philosophic Mercury in 1675.

The essence of alchemical writings has been consistent through the centuries, while the details have been inscrutably and defiantly deceptive. Philalethes is called the last great alchemist in print. This collection presents a treasure map for many uses.

# Triad

125 West Front Street, Suite 275 Wheaton, Illinois 60187 USA  
Fax/Phone (708) 665-1417

Triad was born more than ten years ago out of our efforts to obtain materials for our personal alchemical research. Since that time, we have helped many people to obtain unusual or hard-to-find materials. The materials listed below are (with the exception of antimony ore) in very limited supply, and we are not certain that we will be able to replenish our stocks once these supplies are exhausted.

**All materials subject to prior sale, due to limited supply.**

**Refund sent for out-of-stock materials unless you specify alternate choices at time of order.**

**★ WE NOW ACCEPT VISA AND MASTERCARD ★**

## MINERAL & SPECIAL ITEM PRICE LIST - May/June 1995

 **On sale for limited time! ANTIMONY ORE:** Purest stibnite available. Bolivian, almost pure  $Sb_2S_3$ . Assay: 71% Antimony, 0.07% Lead, 0.08% Arsenic. Can be used without separating gangue when making regulus. As used by LPN France. Regular prices: 1-5 lbs, \$10/lb; 6-24 lbs, \$9.00/lb; 25-49 lbs, \$8.00/lb; 50+ lbs, \$7.25/lb. **Special Sale Price until 6/30/95 - only \$7.00 per pound - 5 pound minimum order.**

♀ **ANTIMONY TRIOXIDE:**  $Sb_2O_3$ . Commercial. Useful in making glass of antimony. Price per pound: \$6.00.

 **Just Added - CANADA BALSAM:** This liquid oleoresin from *Abies balsamea*, the Balsam fir, is useful in works on the Circulatum or liquid plant stone per Urbigerus and Manfred Junius. The real thing! 60 ml: \$29.95. 30 ml: \$16.75.

 **Sorry! - CERUSSITE:** Native lead carbonate ore from Arizona. **Sold out in a few days!**

 **Just Added - CHALCANTHITE:** Blue vitriol, native copper sulfate ( $CuSO_4 \cdot 5H_2O$ ). Sky to medium blue crystals, slightly curved. Readily purified from matrix by dissolutions in water & recrystallization. Very limited supply. Price per pound: \$6.50. Better hurry - this will be gone in a few days!

♀ **GOLD:** Generally 87-89% pure, placer gold. Check on availability and price. This is special order - not in stock.

♀ **KAOLIN:** (Bolus alba) Refractory clay useful for coating heating mantles. Price per pound: \$6.00. \$3.50/ 8 ounces.

♀ **LEAD CARBONATE:**  $PbCO_3$ . Commercial. Useful as learning material in acetate works. Price per pound: \$7.50.

♀ **LEAD OXIDE, RED:**  $Pb_3O_4$  (Minium) Commercial, 98% pure. Useful in acetate works. Price per pound: \$9.00.

 **Going fast - RETORTS:** We received shipment on the last retorts that we can find in the US this past Fall. These are Czech-made, probably in the 1930's. They are 150 ml size, tubulated, with a ground-glass stopper. Good borosilicate glass. When these are gone, sadly, there are no more. At \$30.00 each they are a bargain.



♀ **SEA SALT:** From France. Not the 'flower of sea salt', now sold out. This is the normal quality of sea salt collected by evaporation in clay beds in northern France. Used as matrix for synthetic plant stones. Price per pound: \$5.00.

 **Save 10%...SULPHUR:** Native sulphur, western US. Medium to high quality. No large crystals. Regularly: \$8.00/lb. Only \$7.20/lb until 3/31/95.

♀ **SULPHUR:** Native sulphur from Italy. Medium quality, some pieces with large crystalline masses. \$9.00/lb.

 **Price Reduced... SUNDEW:** (*Drosera rotundifolia*) Imported from Europe. Unique, insect-eating said to be a 'vegetable antimony' with interesting experimental possibilities. Regularly \$15.00 per pound. **Now only \$12.50.**

♀ **TARTAR:** Red wine tartar from France. Price per pound: \$8.00. Shipped in plastic bag.

**Upcoming:** Sue and I are looking for galena and more cerussite - will keep you posted.

Our inventories include absolutely pure essential oils, herbs, books on alchemy and other esoteric topics (all books 10% off list), chemicals, mineral ores and laboratory equipment. **PLEASE INQUIRE.**

---



---

# ORA ET LABORA

---



---

Vol. 2 No. 1

Copyright 1995, The Philosophers of Nature

March 1995

---

## NEWS FROM THE PHILOSOPHERS OF NATURE RESEARCH GROUP

---

### THE EDITOR'S CORNER

by Russell House

We are pleased to announce the return of *Ora et Labora* in a new format, which should be of benefit to our membership. Symbolically, *prayer and work* are incorporated into *The Stone*.

*Ora et Labora* was published monthly from January 1994 through August 1994 as a separate newsletter by the research and seminars group of The Philosophers of Nature. The issue being prepared for publication in September was never completed for several reasons. Sue and I were incredibly tired after the 3rd Annual Seminar, and have had, since then numerous other obligations to fulfill. It had become increasingly difficult to find the time to prepare the newsletter each month, and there were insufficient articles to continue publishing as in the past. Further, it seemed that it was not in the spirit of the organization to have information circulating among a research group that was not benefitting the membership as a whole. Finally, it made no sense to maintain two newsletters (with both struggling to get suitable articles) within an organization with just over a hundred members.

The enthusiasm that was, for a time, demonstrated for *Ora et Labora* leads me to believe that members enjoy having practical information, whether or not they are presently active in research. It is my hope that the return of *Ora et Labora* in this new format will encourage those who are working to share their experiences in the laboratory, and will stimulate those who are not currently working to begin or to start again.

Many beneficial articles were published in 1994, and yet many who are conducting valuable research choose not to share information for various reasons. Certainly, each person

must decide for themselves the boundaries of privacy in regard to what they reveal, and not all are comfortable writing or have the time to do so. I have wondered how much impact the age-old tradition of secrecy that is associated with Alchemy and esotericism has had on the those who decided not to write.

It may be interesting, at this new beginning in the Spring season, to take a renewed look at secrecy. Why is secrecy part of the tradition? Do the conditions that required it in the past exist today? If secrecy has any role today, why is that, and what things are not meant to be revealed? What are the positive and less positive consequences of secrecy? How have you benefitted from those who have taught with an 'open' style, compared to those who are more 'closed' and secretive?

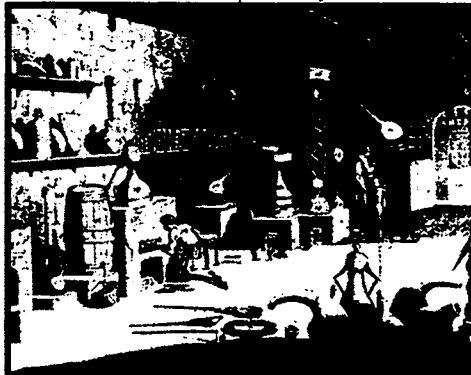

It must be a personal realization, I think, so that each one is guided by the highest aspects of Self. For those who are desirous of becoming free men and women, it can be useful to review traditions, habits and beliefs with new eyes, rather than to conform blindly to any tradition.

### New Research Group Guidelines

When the Research Group was first formed in April 1993, the objective was to identify members who had some interest in research, whether or not they presently had experience in conducting research. Those who could provide funds, help with translations or record keeping, and those who felt that they might want to actively participate in research in the future were all asked to come forward.

## 2

After six months of publication of *Ora et Labora*, and several more months of contact with members, it was decided to make some changes in membership criteria. The purpose of this change is to strengthen the research group by adding necessary focus, but without restricting the flow of information or creating a pseudo-hierarchy. This latter point is a most important one, because it is not in accordance with the aims of the organization to create 'inner circles' or to set some individuals aside from the rest of the group.

In the June issue of *Ora et Labora*, a change in criteria for membership in the research group was proposed. Some members did offer feedback regarding the proposal, and we are now confident in announcing the new membership policy.

I. Effective March 21, 1995, any active member of The Philosophers of Nature (under the new membership guidelines as published in *The Stone*, which require an annual membership fee), may apply to join the research group. There is no cost to join the research group over and above the cost of membership in The Philosophers of Nature. However, one must submit at least one of the following in order to become a member:

- A. A proposed research project, complete with procedures, safety concerns and criteria for recording results clearly stated in suitable detail so that qualified researchers could carry out the project.
- B. An article which clearly details the results of a research project which was performed by them, in the fields of alchemy, qabala, esotericism or related topic.
- C. A research paper with content as above, but which may be on a topic not suitable for general publication.
- D. A similar contribution of practical use in supporting or expanding research, which is acceptable to the research coordinator.
- E. Suggested additions to or modifications of the existing lessons based on first-hand experience or knowledge.

II. In any case, only work actually performed by the researcher will be deemed acceptable. A team may submit results of a group work, but each member must have been an active participant in the project. Purely theoretical or speculative articles, or compilations from the library are not suitable for submission to fulfill membership obligations.

III. Members must submit new projects each year in order to be active members.

The goal for 1995 is to identify members who are willing to work, to identify specific research projects which can be conducted, and publish the results for the benefit of members here and abroad. If you are willing to share in this effort, send correspondence to:

## ORA ET LABORA

The Philosophers of Nature  
Research and Seminars Group  
0 South 651 Jefferson Street  
Winfield, IL 60190 USA  
Phone/Fax 708/665-1417

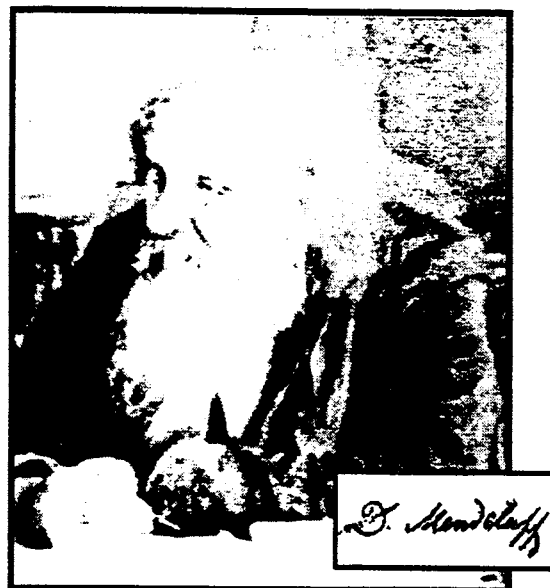

**Dmitri Ivanovitsch Mendeleeff**

(1834-1907)

Mendeleeff proposed his ideas regarding a periodic table of the elements in 1869, as had Newlands, a London industrial chemist, in 1863. The most famous of the Russian chemists, Mendeleeff was born in Tobolsk, the youngest of 14 children. Despite the hardship caused by his father's death, his mother moved to St. Petersburg in 1850 and managed to start her son in studies in physical and mathematical science at the Central Pedagogic Institute. Later, Dmitri studied at Heidelberg and Paris, and in 1866 was appointed to a University chair of Chemistry at St. Petersburg, where he was widely acclaimed as a lecturer.

In the dedication to his book Solutions, Mendeleeff reveals the dying words of his mother, which he held as sacred, and which all researchers would do well to regard as a motto:

**“Refrain from illusions, insist on work, and not on words. Patiently search divine and scientific truth.”**

# Secrecy, Revelaton, & Desire

*continued from page 1*

your door to get it. The location of your lab may be another valid "secret."

There is a commingling in our Art of secrecy, "blinds," greed, and selfish desire; perhaps the promise of gold and immortality inevitably draw these forth from our minds. It falls upon us all to tease out the subtle from the gross and examine the nature of our secrecy: Does it serve the whole, or does it feed our greed and perceived self-importance?

The Philosophers of Nature encourage the exchange of information for the betterment of the whole; indeed this is one of its main purposes. Several projects are in development to bring more seminars to the US and publish new material. We are always open to your ideas and encourage everyone to contribute. This will nourish us in the present and makes us stronger for the future.

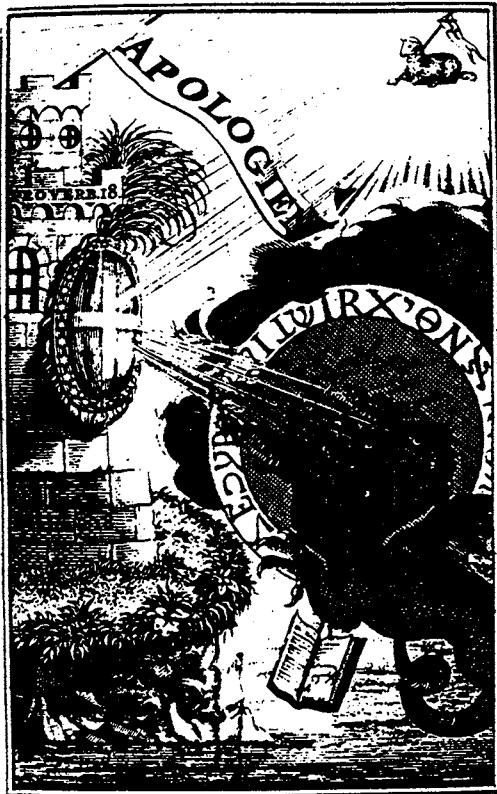

## "Who Do I Contact When..."

I have questions about my membership?"

I have problems receiving my lessons?"

I would like to subscribe to The Stone?"

I need back issues of The Stone?"

Write or call the administrative headquarters: Philosophers of Nature, P.O. Box 11218, Boulder, Colorado, 80301; Phone (303) 443-8199 between 9am & 5pm Mountain Time, Monday through Friday.

I have an article or letter for The Stone?"

I have advertising for The Stone?"

Write, call, or e-mail the editor: The Stone c/o Ken Miller, 405 West Washington Street #314, San Diego, CA 92103-1994. Phone (619) 528-4521 (keep in mind Pacific Time). E-mail: StoneLPN@aol.com

**Please Note: MAILING YOUR INQUIRY TO THE WRONG ADDRESS COULD DELAY MATTERS FOR MONTHS.**

### • About The Stone

The Stone is published three times a year in March, July, and November, primarily for the benefit of the membership of the Philosophers of Nature. We hope to get members' feedback regarding what they would like to see in it. Articles, photographs, drawings, letters to the editor, and comments from members or others are solicited for submission to the Editor for evaluation. Submissions and advertising should be sent to The Stone c/o Ken Miller, 405 West Washington Street, Suite 314, San Diego, California 92103-1994. E-mail may be sent to StoneLPN@aol.com. Deadline for submissions and advertising are as follows: February 20th for the March issue; June 25th for the July issue; October 25th for the November issue.

### • Advertising

The Stone accepts advertising for both display and classified ads. Rates are as follows: Full page: \$100.00; Half page: \$60.00; Quarter page \$35.00; Classified ads are \$0.10 per word. For more information write the editor, Ken Miller at the address listed above, or e-mail him at StoneLPN@aol.com

### • Subscription to The Stone & Membership Information

The Stone is included in the cost of membership. Non-members may subscribe at the rate of \$20 per year (three issues). Subscription requests and any questions about membership should be sent to the administrative headquarters: Philosophers of Nature, P.O. Box 11218, Boulder, Colorado 80301. You may leave a message for the office manager at (303) 443-8199 from 9am to 5pm Mountain Time.

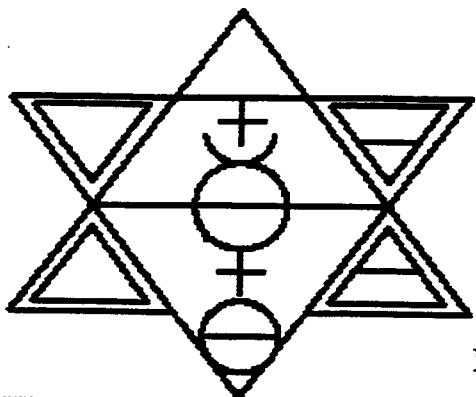

# The Stone

& ORA ET LABORA

Journal of The Philosophers of Nature

Issue Number 13

July 1995

## PON Presidential Message

Dear Friends, there are some new changes in administration concerning the PON and membership. For better or worse I have been handling the bulk of the membership duties for the PON. Since April of 1988 I have been tending to this duty for there was no one else at the time to pick up the challenge. Since then the PON has grown and its needs have changed. There is no longer room for creative and chaotic administrative techniques.

From time to time I would get some help from secretaries. I have become less and less able to attend to the details of the administration aspect because of basic burnout. In short I am a spent penny.

While visiting our French brothers and sisters in June I asked Russ and Sue House if they would be willing to take over the distribution of lesson materials and attend to the basic running of the office of the PON. They graciously agreed to do so. In retrospect this move should have taken place a year or two ago.

Some individuals are slow to make the necessary changes. I apologize for the frequent delays in answering letters or responding to orders for lessons.

I want to give special thanks to Karen High for offering her services for the past two and a half years. Her career has led her away from the Boulder area and was unable to continue as the office manager. Instead of picking up the challenge once again, I felt the mentioned changes were in order.

The address for questions concerning membership will move to Winfield II. as a matter of convenience. Since Russ and Sue will be handling membership we certainly do not want to have the mail coming to Boulder where it might sit for a few weeks.

### Rumors can be tumors!

Now it is time to dispel some rumors that have been flying around. These are always somewhat humorous. Where do these false ideas come from, and how do they get out of control? (Please refer to the article "An Antidote for Rumors" for a complete separation of fact from fiction).

First of all I will not be resigning as president of the PON as of yet. I have however given up the administrative responsibilities mentioned above to those who are far better qualified to do them. I do not expect to be president of the PON forever. Sooner or later as it

*(Continued on Page 11)*

### In This Issue...

Presidential Message	page 1
News About Alchemy	
<i>by Adam McClean</i>	page 2
PON Tour of France, May 1995	
<i>by Russ House</i>	page 3
A Note About the Tour	
<i>by Sue House</i>	page 8
How to Prepare Wine Spirits	
<i>by anonymous</i>	page 9
Survey of Occult Fiction & The Red Lion	
<i>by Tim Scott</i>	page 10
Philosophers of INTERNETure	
<i>by Russ House</i>	page 14
Advertisements	pages 16-18
ORA ET LABORA	PAGES 19-21
An Antidote for Rumors	page 22

The Stone, Issue Number 13, July 1995. Published in March, July, & November by the Philosophers of Nature. Editor: Ken Miller. Subscription details on page XXII. © 1995 Philosophers of Nature.



should be I will take my place among the membership and someone else will take over as president. Hopefully this will be a smooth transition.

I am happy to report that there is a deep trust and harmony between the board members of the PON. We will continue to work in such a manner.



## News about Alchemy

### From "The Alchemy Home Page" by Adam McLean

*Internet address: <http://www.colloquium.co.uk/alchemy/home.html>*

#### M. P. Hall Alchemical manuscripts

The John P. Getty Museum in California has recently purchased the collection of alchemical manuscripts made by Manly Palmer Hall, the well known writer and lecturer on alchemy, hermetic philosophy and mysticism, who died a few years ago. M.P. Hall worked through the Philosophical Research Society in Los Angeles, and after his death a dispute arose regarding his extensive library. There was a danger of the manuscript collection being sold off piecemeal, but now it has been bought as a collection by the Getty Foundation. The collection consists of 245 items (some bound together), and among the more important items are:

- \* A collection, in 18 volumes, of English translations of key alchemical works, made by Sigismund Bacstrom in the 19th century.
- \* The Cagliostro collection of alchemical texts, for the most part in French.

- \* A finely coloured manuscript of the Flamel hieroglyphic figures of Abraham the Jew.
- \* A 17th century copy of the Ripley Scroll.
- \* Some manuscript material of the mystical writer D.A. Freher, including some coloured figures and a copy of his will.
- \* A copy of the Rosicrucian 'Geheime figuren', and 18th century compendium.
- \* Copies of the 'Rosarium philosophorum', 'Crowning of Nature', 'Donum Dei', the 'Claudio de Dominico Celentano Vallis Novi' manuscript, and the 'Solidonius' series, all with series of water-coloured illustrations.
- \* A series of water-coloured drawings based on Michael Maier's 'Atalanta fugiens'.
- \* A number of magical and cabalistical works.



### DID YOU GET THE PREVIOUS ISSUE OF THE STONE ?

If you are a member of The Philosophers of Nature, or are a subscriber to The Stone and did not get a copy of The Stone around the end of May, or beginning of June this year, we would like to send one to you. Some of you did not receive the newsletter due to an error in our mailing list. Please send a brief note to:

The Philosophers of Nature  
125 West Front Street, Suite 263  
Wheaton, IL 60190,  
or call us at 708.665.1417.

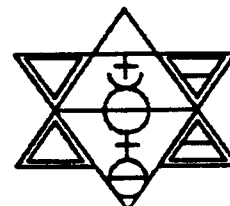
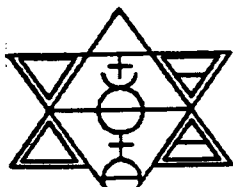

# The Philosophers Of Nature Tour of France

May 13-29, 1995

by Russ House

After many months of planning by Sue, the tour of France was underway. This was to be the third time that Sue and I had travelled to France, and we were excited that we would be travelling in the company of our friends from the Philosophers of Nature. While we had formed friendships with a number of members of the French LPN when they came to the US for seminars, it was not until we had visited with them in France that we began to make deeper connections, to understand more vividly their world, and the influences that French culture has had on the world view of LPN. I think it is safe to say that most of those on the tour made some deep inner connections within themselves because of their experiences on the trip. For me, the immense beauty of nature in the south of France is such that I long to live there at some point in the future. I know that this region similarly affected several people.

There is a style of life in France that is difficult to understand as an American. Take a McDonalds gobbling American and plopping them down in a strange world where two hour lunches, three hour dinners, and five weeks of vacation are normal. To me, the French seem to have an inexhaustible appetite for lively conversation and jokes, for robust red wines, tasty liqueurs and equally potent black coffee. Their passion for ideas, the arts and philosophy, and their healthy acceptance of sexuality can be quite refreshing to fugitives from the TV wasteland. I think it is no accident that TV in France is rather boring with few programs; perhaps for the French life itself is more interesting. They do get Bay Watch, however.

Travel is broadening - it helps to create new perspectives from which to view life. Even the most common place events, the events that we manage to navigate while relatively asleep and self-absorbed, take on a new dimension when one is in an unfamiliar culture. Just how do you take a shower without a shower curtain and not get water all over the place? What is this 'extra' porcelain thing for in the bathroom?

It is not only Americans who can learn from travel. When our friends from France have come here, they have also been broadened by their experiences and their exposure to our culture. You don't get California scenery, cheap gasoline and Corvettes in France. There is also something of a pioneer spirit, and the triumph of dazzling and amazing accomplishment

that is uniquely expressed by Americans. The younger French like our rock and roll, and want to be like Americans. Seven year old boys try to look like the Americans they see on TV. We do not have fifteen centuries of history to live up to in the United States. Because of this, we have a less burdensome egotism, or group consciousness, to overcome than the Europeans. We may sometimes be the less rich for it in terms of depth and breadth of culture, but we are also more free because of it. Freedom from the secrecy of the past, largely caused by the oppressive power of the Church, is one foundation of LPN France. If the ideas of LPN have accomplished something in France where strong esoteric and church traditions are simultaneously visible in every old city (for examples, the Notre Dame of Paris, Chartres cathedral, Rennes la Château), what more can these ideas accomplish when transplanted to America?

## SUN. MAY 14

After a long flight, we arrive in Paris, and clear customs with little delay. Despite being tired, we are excited to return to France with our good friends. It will be a challenge to stay awake until bedtime, since we avoided sleeping on the plane, but it is the best way to avoid jet lag. It is great just to be here! Our tour director Tamara, greets us and directs us to the waiting motorcoach, an attractive magenta-violet tour bus with the name of the tour company emblazoned on the side - COSMOS. We are to travel through France in the heart of the Cosmos. We meet our driver, Enzo, and we drive through Paris to our hotel. After a bit of relaxation we meet to drive to the area Montmartre, with its lovely Church of the Sacré Coeur or Sacred Heart, built in 1870. While I find it a very pleasant spot, it is always a very intense visit for Sue. We are joined for dinner by Jean Dubuis, Josette, Patrice and Lisette in a restaurant near the church. Many tasted kir for the first time - a white wine with creme de cassis, a black currant liqueur. From this high hill, one of the seven hills of Paris, one can see up to 50 kilometers. Paris is beautiful and jewel-like at night. We bid our French friends farewell until our return to Paris. All together, there are 22 of us on the tour.

## MON. MAY 15

In the morning, we drove to the famous 12th Century cathedral at Chartres, where we join a lecture given by Malcolm Miller, a well known expert on Chartres. We were disappointed that we were unable to visit the

crypt which houses the black virgin. The stained glass windows here are among the finest in the world, and much has been written on the special blue and red colors of the glass. Many, such as Fulcanelli, have considered Chartres to be an alchemical book carved in stone by the Gothic cathedral builders. The symbolism in the statues, the carvings on the facades, and in the stained glass are so rich that one could spend years in their study.

Back on the bus, we travel through the beautiful countryside to the Palace of Fontainebleau where we visited Napoleon's Wing and walked through the lovely gardens. On the horse shoe shaped double staircase in the courtyard, one can see carvings which alternate between the caduceus of mercury, and a staff that is surmounted by the symbol of antimony. It is from this staircase that Napoleon the First addressed his troops for the last time before his exile. Many of the personal belongings of Napoleon and his family are preserved in the exquisite palace. We depart for a long trip toward the north, to the border between Brittany and Normandy where we spend the night a short distance from the impressive Mont St. Michel. Many of us walked during the night to a point where we could see the spire of the cathedral reaching far above the mountain.

#### TUES. MAY 16

In morning we drive to the Abbey of Mont. St. Michel, and see the sheep grazing on the marsh lands. The grass is full of the salt from the sea which covers many of the low lying areas at high tide, and so the sheep are naturally seasoned with salt giving them a distinctive flavor. Mont St. Michel is an amazing natural wonder, a massive rock rising from the sea, crowned by an enormous abbey church. over which the Archangel Michael spreads his golden wings. On this site, in ancient times, the Druids worshiped Belen, the god of light; later the Romans worshipped Mercury on this little mountain. Around the end of the 5th Century, Christians came to this isolated place, ideal for prayer. In the early 8th Century, according to legend, St. Michael appeared three times to the bishop, instructing him to build a sanctuary in his honor. The present church has had various cycles of construction and repair or modification, primarily between the 11th and 15th Centuries. It is in this old church that Jean Dubuis had his first Inner Initiation at age 12, as a result, the young boy recalled his past incarnations. We stop at Rennes and pass the night in Angers.

#### WED. MAY 17

The group then went on to visit the unique Angers Château, dating from the 14th Century, with its beautiful Tapestry of the Apocalypse, then on to Fontevrault, the medieval abbey which contains the tombs of

Henry II of England, his wife, Eleanor of Aquitaine, and their son, Richard the Lionhearted. Our last stop for the day was at Château Blois, before we return to our hotel in Angers.

#### THURS. MAY 18

Chenonceaux, the 16th century château of Catherine de Medici, is one of the most lovely places in the Loire valley. The gardens make a wonderful vantage point from which to enjoy the delicate and unique architecture of the castle. For a short time, the famous alchemist Saint-Germaine lived here. The chapel of Catherine is small, and yet very peaceful, despite the large number of tourists moving through. Next, we traveled to the impressive fortress-castle of Amboise, royal residence of Charles VIII and burial place of Leonardo da Vinci. It was sobering to see the remnants of devastation caused by World War II, in the form of holes in the faces of the castle caused by small arms and cannon fire during the early part of the war. I have paid attention to the damages of that war on previous trips to France and find that it brings a certain sadness.

At nearby Clos Luce we saw the amazing collection of models of Leonardo's inventions, painstakingly reconstructed from the drawings of the great Renaissance genius. It is here that we had a difficult time when I left with two companions to photograph the birthplace of Louis-Claude St. Martin, the mystic who organized the rites of Martinism. We misjudged our ability to get back to the group before they were on the bus to depart for Bourges, and the rendezvous point was not where we had expected. As a result there were over two hours of great agitation for everyone. The three of us bought bottles of wine for the rest of the group that evening. We drive to Bourges where we spend the night. After dinner, I walk with some friends to the center of Bourges, to the Palais Jacques-Coeur, one of the most sumptuous Gothic dwellings in France. This 13th Century palace is also mentioned in the writings of Fulcanelli. The facade has symbols of the scallop shell alternating with those of a heart. The scallop shell is a symbol of the pilgrims to St. Jacques (James) of Compostella, and so we have the first name of the man, along with the heart (Coeur) making the last name.

#### FRI. MAY 19

In the morning, we visit the 13th century Cathedral St. Etienne with its elaborate representation of the Last Judgment carved on the central portal. This is considered to be a masterpiece of medieval sculpture, with its clusters of cherubim, angels, saints, and prophets. Inside the cathedral one will find the scallop shell, as this cathedral is one of the resting places for pilgrims today, just as it was 700 years ago.

Nearby in Bourges, we visit the Hotel Lallemand, a residence of a family of alchemists. This residence is discussed extensively in Fulcanelli's *Les Mysteres des Cathedrales*. In the room where we bought tickets, I was explaining to people that the fireplace here is much too small to have been used for cooking for a family, as was often supposed, and that this was in fact an alchemical laboratory, and not the kitchen. A voice says, "Of course! Absolutely," and we have found a tour guide that is aware of the alchemical symbolism of this most exceptional building. Unfortunately much of the facade of the building was under restoration when we visited, so some of the symbolic carvings were not visible. Still, our guide pointed out as many features as possible on the exterior of the building. He indicated the four levels of the tower in the courtyard, each level with differences in style and decoration. These indicated, he said, the elements earth, water, fire and air from bottom to top (the qabalistic sequence of the elements, rather than their alchemical sequence).

In the chapel of the alchemists, one enters into an oratory with much of the finest alchemical symbolism in France. The stained glass, though simple, bears coats of arms with roses having 5 petals and 5 points that radiate between the petals - a symbol of alchemical ad- epts, our guide explains.

The mythology of the Golden Fleece is featured above the door to the oratory, and the carved symbolism on the tops of the pillars is of Hermetic interest. Most fascinating, however, are the square panels that cover the entire ceiling, each square carved with a unique symbol, with pomegranates, cherubs, and other symbols, the whole series being symbolic of the steps in confecting the philosophical stone, from preparation of the prima materia, through its multiplication and projection. After bidding our gracious guide 'au revoir', we stop in one further room momentarily - a large parlor which is unremarkable except for its floor which is constructed from planks in concentric 8-sided polygons. This is symbolic, in my opinion, of the level of Hod, with its correspondence to Hermes-Thoth. Bourges is a town that has aged gracefully, and which I find more comfortable than similar towns in the north. Now we will move further into the south, as we direct our bus toward the pink city of Toulouse.

### SAT. MAY 20

In Toulouse we visit St. Sernin Cathedral, the 11th-century Benedictine abbey, which was at one time the center of the Inquisition. Unlike the more light and airy feelings of the Gothic cathedrals, this is one of the earlier Romanesque constructions, darker and more oppressive. It was interesting to visit this very 'heavy' and Saturnine place on a Saturday. Incidentally, a main feature is the tomb of Saint-Saturninus, dating from the

early 13th Century. We spend some leisurely time in the town square, with its stalls of fruits, vegetables, honey, used books, oriental carpets, and clothing. After walking through the square, it was a tremendous pleasure to sit in the sun, drinking strong black coffee or pastis, watching the people passing by. One can easily begin to get the idea that life in the South of France might not be entirely bad. Near the center of town, one sees the old Donjon tower where it is said that H. Spencer Lewis, Emperor of AMORC first met with French Rosicrucian contacts. In the afternoon we pass through the Garonne river valley through small towns filled with Cathar history: Foix, Montgaillard, and Montsegur.

In the afternoon we tour Carcassonne, the largest medieval walled city remaining in Europe. The city is fascinating, and takes one back to a time when it was necessary to construct the towns to last through sieges by invading armies. One learns of the architecture of war, how cannons are placed, how slits to protect the archers are designed to protect the bowmen but offer a vantage point to fire on invaders. In one tower, a trick is played on enemies in a hurry to storm the city - they take a wrong turn and step out into space. Much of the city was restored by Viollet-le-Duc, who had an interest in alchemy. (See article in *Ora et Labora*). After dinner, I go with friends to see what sort of night life exists in this small town of southern France. We pass on the bar with a band playing American rock and roll, and go for drinks in a club where we watch people play French pocket billiards, a game played with 7 red and 7 yellow balls and one black ball. After watching two or three games we cannot figure out the rules. A player will miss a shot and still take 1 or even 2 more shots afterwards. Finally we go to another club, where we find locals who speak enough English to teach us the basics of the game. Still moderately confused, we walk the long road back to the hotel.

### SUN. MAY 21

The group decided to add a visit to the mysterious Rennes la Château to our itinerary. Joe Tyls and Saul Pressman have made a long study of this site of the Templar treasure and encouraged us to go there. A synopsis of their study was read to the group as we traveled through some of the most awe-inspiring mountain scenery I have ever seen. We stopped in Rennes la Bain to try and find someone to point us to the right road to our destination. Tamara came back and said that a Belgian man was willing to drive there so we could follow him. As it turned out, Mr. Beaujean Eddy is completing a book on Rennes la Château, and was visiting for a few days to conduct some research, the second 'chance meeting' with a tour guide. He made himself available to us for our entire time there.

During a discussion with two or three of us, Mr. Eddy explained, in French, that he had been contacted by extraterrestrial intelligences some years ago, and that he received a transmission of knowledge from them that had taken a period of three years to unfold. This time was necessary for him, so that he could retain his sanity. Because of the transmission, he had acquired a knowledge of chemistry, astronomy, insights into the naming of places on earth and how they related to celestial things, the methods of healing with plants, and numerous other branches of knowledge. He was puzzled why he would be the recipient of this blessing, since he is not an educated man, and is nothing special. He considers the explanation of this information to be his mission now, and he will use the book as a means of doing this. During his stay in the area, he sleeps in an underground grotto, on an ancient altar. In one of these underground places, he found a triangular or pyramidal white stone, with the word 'vitriolum' carved on it, which he connected to alchemical symbolism. We will keep in touch with this kind gentleman and eagerly await publication of his book.

The history of Rennes la Château is shrouded in mystery. In the 1800's the church in the area was very poor, and Saunière was sent there as the priest in 1885. He turned over one of the stones in the floor of the 9th century church one day and found the other side to be carved with the symbol of the Templars: two knights on a single horse. His further explorations allegedly revealed some bones and ancient manuscripts of the Templars. In a few years time, he spent millions of dollars on the church, making beautiful and colorful statues, stations of the cross, and other buildings. It is said that abbé Saunière had discovered the treasure of the Templars.

Montpellier, another quite lovely and historical city was visited in the afternoon, and we spent the night there. This is a university town, with numerous gardens, and a fountains. Here we saw evidence of the French interest in fine lingerie in many of the fine shops, and further signs of 'Lou'. Lou is a company that makes lingerie, and we had seen in every city since Paris the latest advertising which shows an attractive French model in the latest line of garments. "Look, there's Lou" was a common phrase on the tour bus.

## MON MAY 22

Leaving Montpellier, we drove through the many vineyards of Languedoc-Roussillon, and saw many fields of grass with a sprinkling of the small red poppies that are characteristic of the region. At Pont du Gard we stopped to see the Roman Aqueduct on our way to Avignon. Passing through Aix-en Provence, we travelled to Nice. The famous film festival was underway in

nearby Cannes. In Grasse, the fragrance center of France, we visited a perfume factory and saw many of the traditional copper distillation vessels for steam distillation of essential oils. One finds fine lavender, and rosemary and other aromatic plants throughout this region. We also saw examples of how jasmine absolute was formerly extracted from the petals through enfleurage, a method which used purified animal fats to extract the delicate plant oils which would not survive the temperature of distillation. I noticed that the laboratory was full of the typical synthetic ingredients of modern 'chemical' perfumery, since they are added to the natural essential oils which are also 'cut' with synthetics to increase profitability and to meet the needs for oils which smell the same from batch to batch despite annual variances in growing seasons and the effect it has on the oils. While it was quite interesting to me, I had a sickly feeling after leaving this palace of synthetic aromas. As the sun was setting, we traveled to nearby Monaco where we saw the residence of Prince Rainer and the late Princess Grace. I left an undisclosed amount of francs (glad it wasn't 'real money') at the casino in Monte Carlo.

## TUES. MAY 23

On our way to Lyon, the country's second largest city, we passed through beautiful Provence, much loved by Van Gogh and other artists. To make the long trip a bit shorter, we took a tollway. We had elected to have a bus without a toilet, since there are no facilities in France to clean this sort of toilet, and we would frequently stop in search of facilities along the highways during our tour. After observing the zeal with which we would descend on some tiny (and often primitive) toilet facility, it was suggested that we get T-shirts that say "Potty Animal".

We briefly visited St. Mary Magdalene's Basilica in St.-Maximin la Sainte-Baume. The crypt here dates to the 4th Century. The ancient reliquary of the skull of St. Mary Magdalene was stolen and broken during the French Revolution. The present one dates from 1860, and preserves the skull atop a delicately clothed statue of the saint.

Our tour director, Tamara, had determined that we were not the usual tourists and suggested that we visit the house of Nostradamus in Salon-de-Provence. She had expressed some amazement at how we would always arrive at a place and attract the proper guides, as though they were there waiting for us. As we were looking though the house of the noted 16th century prophet and alchemist, a man came in and spoke to Tamara. He explained that he lived a few towns away and came here usually once or twice a year, but had been 'told' to come to this place, because he might meet

some alchemists today. I spoke with him and learned that he was a teacher on medieval studies, and that he was now part of a project to restore an old home that had until recently been a four-star hotel. The old home had belonged to a family of alchemists in the past, and was covered, he explained, with hermetic symbols and carvings. He believed from some of the symbols that John Dee had been involved with this place and this family. Their coat of arms, given to them by the king, had a letter "Y" on the shield (their family name began with this letter) and the center, or cross-point of the Y was surmounted by a rose. Once the place was restored, it was hoped that it could be made a place for retreats and seminars by alchemists. He was pleased to receive addresses of our friends in France, and we will keep in touch with him. Tamara was, of course, amazed once again. Making our way on to Lyon, our home for the night, we saw numerous medieval buildings near the center of town. Already, I regret leaving the south of France, as though each mile traveled further separates me from a part of myself.

### WED. MAY 24

In the morning we traveled through the valley of the River Saone into the Burgundy region, famous for its fine wines. In Beaune, the center of the wine trade of France, I sat and took it easy with a glass of wine while Sue had a kir. It was her birthday. In Dijon, the historic capital of Burgundy, we shopped, and then traveled to Reims, center of the Champagne industry. Patrice and Lisette joined us there to celebrate Sue's birthday, and we had dinner and then went out to see the lovely town at night.

### THURS. MAY 25

The 13th Century cathedral of Reims is where Joan of Arc arranged the consecration of Charles VII. A cathedral dating to 401 AD on this site was replaced in 852. After it burned in 1210, the construction of the present cathedral began. The sculpture on this fine Gothic cathedral is wonderful, and the famous 'smiling angel' is a masterpiece of the period. Jean Dubuis had suggested we visit the smaller Basilica St. Remi, which he felt to be of more esoteric interest than the large cathedral. Afterwards, we visited the famous Mumm's champagne winery, and visited the cellars with many musty underground 'streets' stacked with bottles of champagne. By the way, the French refer to Coca-Cola as 'Champagne Americain'. We pass through the beautiful Ile-de-France on our way back to Paris.

### FRI. MAY 26

The bus takes us along both banks of the Seine where we see many of the notable sights of this lovely European capital. The Arc de Triomphe, the Opera, the Madeleine, the Invalides, the Louvre, Champs-Elysees,

the Eiffel Tower, and the Notre Dame. At noon we left the tour, to meet with Patrice and Lisette for the day, while others made arrangements to visit the Louvre, Versailles and other local sites during the free times over the next few days.

### SAT. MAY 27

In the morning, Jean Dubuis joined us to give a lecture on esotericism and to explain something of the new lessons he is preparing. He also spoke briefly on the difficulties in the LPN in France, which lead to his decision to resign from the organization which he had founded in 1978. After lunch we take advantage of the free time to rest, to see more of Paris, to meet with friends.

### SUN. MAY 28

After lunch, Jean gave the second part of his lecture, and we prepared for our farewell dinner on the Seine. This was a most memorable event, and a fitting end to a 'whirlwind' tour of the rich cultural tapestry that is France. As our boat traveled on the Seine, we saw the numerous bridges, monuments, and historical buildings of Paris, as though we passed through the centuries in moments. The spirited violin music moved our friend Irene to dance, and expressed perfectly the carefree feeling of the cruise. To be in Paris, in the Spring! To dance on the Seine! To laugh in the land of centuries of history, so that this moment too is not forgotten!

### MON. MAY 29

We piled on the bus for one last time, and said goodbye to our newest friends, Tamara and Enzo. By the end of the day, everyone would be en route to the US again, and Sue and I would spend a few days in Paris with Patrice and Lisette, until Kevin Townley would join us for some business with Jean.

### AFTER THE TOUR:

On Monday we traveled to a place that sold masonic and esoteric supplies to find a Martinist sword for an American friend. The swords were not of suitable quality, but it was interesting to see a French masonic shop, which sold numerous books, various regalia and incenses. In general the esoteric stores in France are quite good, and I found interesting ones in Paris (several), in Chartres, Rennes la Chateau, and several other cities. There is a significant interest in Alchemy, and numerous books are in print there which are not available in English. Masonic studies are quite prevalent, as well as qabalistic, Rose-Croix, Rosicrucian, Martinist, Elus Cohens, Cathar, Templar, Golden Dawn and similar topics. There is also an interest in various forms of esoteric healing and divination.

On Tuesday, we went to Versailles with Patrice and Lisette. Only Lisette had been before, so it was a great time for discovery for us. The palace of the 'Sun King' Louis XIV is absolutely stunning in its decoration, from the famous Hall of Mirrors, to the luxurious gardens that stretch as far as the eye can see. The murals on the ceilings are the finest mythological paintings I have ever seen, and they incorporate the traditional astrological rulerships as well. For example, a mural dominated by Mercury, will have a virgin and twins incorporated into the work, and a Jupiterian mural will have the centaur/archer as well as twin fishes. This palace is particularly solar in its feel - the use of light, of color, of gold decoration, of symmetry and order, and of radiance in every way. Even in the gardens outside, this solar influence predominates, and it seemed as though there was a special quality to time, as though one were raised up to a new level. I think that the Sun King accomplished something of great interest in making this palace, and I recommend it as a place to visit. Some of the intoxicating sense of this golden palace can be captured from studying a book of color photographs of Versailles.

Later, Patrice drove me to 51, rue de Montmorency in Paris, so that I could see the former house of Nicolas and Pernelle Flamel. The oldest house in Paris, it dates to 1407, and still bears some symbolic carvings on the facade. It is now a restaurant, L'Auberge Nicolas Flamel.

After Kevin Townley arrived, we had several meals with Jean Dubuis and Josette, and discussed business matters related to The Philosophers of Nature. We visited Jean's attorney, a lively gentleman of 93 years, whose offices are in the exquisite home which formerly belonged to the actress Sarah Bernhardt. The offices were decorated in antiques that rivaled those in most palaces. A painting that I was admiring was a 13th century Italian piece. Later, we went to the Jupiter Oak in the forest of Fontainebleau, walked through the extensive English Garden at the Palace of Fontainebleau. We dined at a restaurant that was a favorite of Napoleon I. Since our last visit, Jean's laboratory had been remodeled and was much more efficient and bright than before. He has also turned a former guest room into a computer room, as he is working on a new series of lessons on esotericism, and preparing a course on acetate works in Alchemy.

## EPILOGUE

All too soon, it was time to return to the US. For several weeks after my return, I had moments of the familiar 'home sickness' for France - sometimes it would come as I grabbed for a fast food taco, or when I ate lunch with one hand on the computer keyboard. We exchange news with friends by fax, or by phone, and dream of another trip. Until then, I will have another pastis.

## A Note About the Tour

by Sue House, Tour Coordinator

We were in Paris in the Springtime, and it was beautiful! The weather was warm and sunny all but one day of our trip. The scenery ranged from the busy excitement of Paris, to the grassy marsh lands dotted with sheep in the North, to rolling grasslands in the South, sprinkled with wild red poppies and banked by the snow capped mountains of the Midi-Pyrinees. The South of France was filled with quiet and quaint little villages where 'time' no longer exists and where most of us left a part of our hearts. The trip was designed and planned with the help of some of our French friends to fulfill several purposes. One was to visit some of the historical sites so that we might better understand how and why alchemical and esoteric traditions moved through history to be where they are now in this beautiful country.

The second was to visit the many different regions which exist in such a small country, to experience the change of climate, the cuisine and the differences in their local cultures. The third purpose was to visit many of the sites which are known to stir the 'inner being'. These sites were purposely visited for short periods of time, so that the inner experience was triggered to unfold gently as we travelled, allowing little time for the intellect to take over. We can now use those places where we felt these awakenings to focus on in meditation and allow the experience to manifest more fully. Many of us now know what particular areas of France most stir us, so that we can concentrate on those places when we return individually.

Our guide, Tamara, was truly amazed at all of the 'unexpected' and 'unusual' events that occurred on this trip. People seemingly dropped out of the sky to meet with us, and to give us amazing information which we would otherwise not have received. She said that in the ten years she has been doing tours that she has never met a group that had so many individual personalities, rather than just one 'homogenous' personality. Tamara felt us spiritually and intellectually stimulating and exciting to be with. We were also blessed to have a guide and driver who were caring, warm hearted and open to change. There are no accidents!

This trip was a truly exceptional experience for me personally. I was able to visit a country that stirs my heart deeply in the company of people of like mind and heart. I am grateful to each of my traveling companions for my experiences, made richer by their presence. I enjoyed being and seeing, feeling and experiencing. It is a memory that I will treasure; I have brought home so much to work with and look forward to doing so.

(Continued on Page XV)



# How to prepare wine spirits and sharpen one's humility, part I

*By anonymous*

Fairly late in my practice of the spagyric arts I ran into yet another article by the French Alchemist Solazaref outlining a combination of personal experience and the works of Valentine and Glauber on how to prepare wine spirits, i.e. spiritus vini;

What spiritus vini is not:

- 1) Pure ethyl alcohol
- 2) Wine distilled at 76-78 degrees centigrade and purified over potassium carbonate and calcium oxide.

Those who disagree with the above can go back to wondering why their oil of antimony and potable gold works are not functional.

Take white grape juice for wine making, put it in plastic pails, yeast it, let it rest and transfer it to 4060 litre glass bottles for further fermentation. Put gas locks so as to be able to know when fermentation is over. Rack the wine, resiphon it, don't forget to collect the tartar.

Put wine in another wide necked container and circulate for two weeks at low temperature (50 to 60 degrees centigrade) using one of the very large bulbs described in a previous article. Add a snout to the bulb and distill at very low temperature. Perhaps the expression 'humid sublimation is better than distillation' until droplets replace the nice strait lines in the large bulb. The neck needs to be fairly large (see previous article). It would probably be a good idea to connect the snout to a condenser. The fruit of these works is aqua vitae; note the vitae, it can still be killed by improper manipulation. Aqua vitae can be worked in different ways; here are a few,

Take the AV and circulate it for two weeks over salt of tartar. Sublimate in a humid fashion as described above. Prepare about 6 litres as such. Ask your heart what to do; I will not feed you all this information without expecting some work. Some people may consider alchemy to be an egalitarian democracy; I don't. It is an aristocracy of sweat.

If you are so inclined take some of the spirit and add it to a quantity of raw wine; proportions vary, more work being required to tie this down. Conduct a

careful humid sublimation using a helmet and a neck a little shorter than your forearm. Take out a quantity. Take a drop and see if it makes it to the floor. Test other alcohols. Compare. Have a glass of wine. You've earned it. Obtain copies of the works of Valentine and Glauber from more than one publisher. Read them carefully; there may have been translation problems or deliberate disguising of information, but the basics are there.

Harvest grapevine in the fall. Calcine it no higher than about 600 degrees centigrade. Prepare the salt in hot water. Give thanks to the Birther of Creation and get a hold of the RAMS version of 'The last will and testament of Basil Valentine'. You will also be needing some proper salt of tartar along with proper sal armoniack. We are talking about the preparation of real spirits here; not the commercial kind that at best will help you fight off the effect of exotic preparations/people or possibly the depressing effect on your ego of reading this article. If you feel depressed, rejoice!; it means you care. To think one is a 'master' or a 'teacher' with nothing else to learn is the beginning of brain-death. To think one can practice this art without a careful review of all literature, including modern chemistry, bio and organic chemistry and pharmaceutical/pharmagnostic is a confirmation of the worst.

Almost as bad as the two above is to think that all the Work of any Kingdom can be done using only equipment and compounds found in current scientific catalogues. To teach in a way that may let on that one has done works that one has not done may be hazardous to your karmic health and earn you a stern review from the Birther (May his/her names be blessed) or your higher self when the time of the life review occurs. Of course, to accept (or to give) such teachings (or any teachings) when the inner voices are clamoring is just as hazardous.

For further works you may want to decide if you want to try commercial ammonium chloride or make it from scratch (distilled deer horn worked with certain mineral and animal spirits)

A word for people who enjoy vegetable kingdom work; get some fresh chelidonia, dry distill slowly ;

*(Continued on Page XV)*



# A Survey of Some Occult Fiction and a Review of Maria Orsi's The Red Lion

by Tim Scott

Life is short and there is a lot to learn. Therefore, it is sensible that a seeker after truth does not waste his time. In the past, I have mentioned to a few friends who are students of the inner world that I had read this or that novel and recommended it highly. To my surprise, they replied that they did not have time for such reading, since they wished to spend as much time as possible either reading something valuable or in other "useful" work.

This attitude surprised me. On further questioning, they expressed doubt that a writer of fiction could impart any useful information concerning matters of importance relative to their studies. I had several points I would like to make to those who maintain this position.

First of all, I am sure we would agree that there is a tremendous amount of worthless occult and esoteric nonfiction. Certainly, the existence of the very bad does not justify indulgence in the merely bad. But the point I am trying to make is that it is more a waste of time to read worthless nonfiction than it is to read worthwhile fiction.

Second, and more important, I would point out that masters of wisdom since history began have used fables, myths, legends and other constructions to teach and pass to future generations their teachings. (Taoist legends, alchemical symbolism, and Sufi tales are just three examples that come immediately to mind.) Would such material be considered fiction or nonfiction? To take my favorite example, G. I. Gurdjieff chose to use a fantastic structure to epitomize his entire philosophy and teaching in the huge book Beelzebub's Tales to His Grandson. I suppose the counter-argument would be, "I don't need such tricks, I would rather read the pure undiluted teaching." Well, things aren't that simple. Theoretically, one could survive just fine on a diet of pure vitamins, minerals, concentrated fiber, fat and other nutrients if they could be properly absorbed by the body. But few would argue that this is a sensible approach to take.

Part of the reason for these teaching approaches is that the student is supposed to do some work to divine the inner meaning. (e.g. meditation, the Ch'an kung-an (Zen koan)). Once the light of inspiration dawns, the

lesson becomes a part of the student that he can never lose.

"Perhaps," the person holding the other view might rejoin, "but it's pretty clear that most fiction is not written with such lofty didactic reasons in mind. What about romance, western or pornographic novels?" I would never claim that all fiction is worthwhile: this is the reason I recommend little fiction to my friends. In fact, there is also a god's plenty of bad occult, spiritual and metaphysical fiction (Lynn Andrews and Shirley Maclaine being two of the most popular and egregious examples).

[Without meaning to digress too much, this could lead to a whole discussion of spiritual frauds, such as the fictitious "Ramtha", "Don Juan Matus", Blavatsky's hidden masters, "the ECK masters," and so on and on. It's more mysterious in the case of Deng Ming-Dao's Kwan Saihung, who supposedly at least really exists.]

The same acquaintances who disdain fiction are yet avid students of history. As the epoch being considered is more ancient, so history becomes more and more a matter of speculation and inference. Then there are old works such as those of Rabelais, Shakespeare and Cervantes that are invaluable for getting a sense of the actual life and thought of those times. Do we really know that everything Plato wrote of Socrates and his other acquaintances are simple reports of actual events? Is the Bible fact, fiction, or a mixture of both? And in what proportions?

Finally, fine literature is fine art, and whether you choose to be interested in it or not, I believe it is rather arrogant to dismiss any type of true art as unworthy.

Although I am loath to marshal arguments by Aleister Crowley, he did not disdain to list fictional works in his list of suggested reading material for the A.:A.: order. In fact he did bend his efforts towards writing fiction, on which I'll comment below.

### *Magicians (and others) write*

Probably the best-known works of "occult fiction" are from the pen of British occultist Dion Fortune. I frankly find them very enjoyable to read, sincere, and demonstrative of a good knowledge of human nature.

Since they are easily available, and it seems many people have read them, I won't review them any further here.

Of course, the most famous magician of this century was Aleister Crowley, an extremely intelligent, if not brilliant, very well-educated man steeped in the classics of Western Civilization. Although he wrote primarily esoteric works and poetry, he did bend his efforts towards the writing of fiction, the results of which are, in my opinion, breathtaking in their ineptitude. He has no discernible sense of character delineation, plot movement or narrative style. His writings are also marked by his characteristic egomania, disdain for the rabble and inability to write a simple phrase when a florid one could be found (like some other writers you probably are thinking of...) When you read his other works, and of his life, you get the feeling that his short stories and novels resulted mainly from his own exalted opinion of his abilities rather than a real desire to write them. His two novels were Moonchild and Confessions of a Drug Fiend. The first is almost laughably silly, but at least the second had the virtue of being modeled on his real life.

No better from a literary standpoint was the novel Frabato the Magician attributed to Franz Bardon. If you have read Bardon, you clearly understand that this was a man possessed of the deepest sincerity and a most profound magical knowledge. However, the novel is more poorly written than most comic books. To be fair, his longtime publisher Dieter Rugeberg pointed out that Bardon really only supplied the framework for the novel, and left it to his secretary to "flesh it out." This apparently didn't really get done either, but Rugeberg felt it was important to publish it anyway. Considering Rugeberg's loyal publication of Bardon's work over the last 30-plus years, I cannot ascribe the motives of greed or opportunism to his publication of this book, but rather a real desire to make available all Bardon's works in any form.

One of my favorite occult novels, or just any kind of novel, is Sea Change: The Evolution of a Witch by Barbara H. Watters. Five other books, of which I am unfamiliar, are credited to her in the volume I have. This novel is extremely well-written and I would describe it as a cross between H. P. Lovecraft and Dion Fortune, partaking of the best qualities of both of those writers. The subtitle should probably have been "The Devolution of a Witch": it is the story of the descent into black magical practices of a well-to-do 17th-Century New England woman. She meets a seafaring man whom she sets up in the shipping business with her own money. When she discovers—through occult remote viewing

experiments—that he is betraying her with women in the ports in which he stops, she becomes insane with jealousy and uses magic to wreak her revenge on him. As she becomes more and more obsessed, her spells and rituals become increasingly horrific. For instance, after his death, she arranges to have one of his women and his illegitimate child sent to her house to be put into her "care," but in reality she makes their lives a torment. Unlike many occult novels written in years gone past, this one does not gloss the grisly aspects and for that reason takes on a realistic and compelling, but not sensationalistic, tone. It can definitely give you the willies.

I have only read one book (The Master Christian) by Marie Corelli, who was all the rage of late-19th Century occult fiction. This is really much more a "spiritual" story than a magic/occult one. There really is no dynamic or conflict between an antagonist and a protagonist in this story, and while I'm sure it's uplifting and inspiring, the hyper-florid Edwardian prose seems extremely saccharine to current tastes (just as current writing would seem crude and graceless to a reviewer of that era).

I would like to enter a note about The Dreamer of the Vine by Liz Greene. Ms. Greene is well-known to astrologers for her works on that subject, but her venture into fiction is very successful. The novel is a fictionalized treatment of the life of Michel de Notre-Dame, or Nostradamus. Again, it is skillfully written and appears to be exhaustively researched, as she luxuriates in details that place the story in its proper time in history.

In the *didactic fiction* area, the works by Richard Bach (Jonathon Livingston Seagull and many later books) are pretty well-known and make easy and uplifting reading. But to my taste, the first book by Dan Millman, The Way of the Sacred Warrior, was more enjoyable. This was presented as nonfiction but in his later works he made it clear it was really just a metaphorical tale.

The Wandering Taoist trilogy by Den Ming-Dao (recently reprinted in a single volume) is invaluable for an entertaining presentation of Taoist legends. Although I haven't researched it, apparently the protagonist of these books, Kwan Saihung, is a real character, still alive and actually experienced the events written about. Not very likely, for anyone who has read the legends of Taoism, but I suppose I should reserve judgment until I know more details.

The works by Carlos Castaneda occupy an odd niche of their own. This is not the first time a literary fraud

has been perpetrated on academics and the public (cf. Shirley Maclaine, J. Z. Knight, L. Ron Hubbard, and a host of other goofballs), but what was unprecedented was the chord that it apparently struck. The first four books partook of a unique ambiance that I still find attractive. Perhaps it was the impressionable age at which I read them. After that, in any case, it became clear that the phenomenon was being milked. But it doesn't appear that Castenada was writing in order to teach, but for some odd reasons of his own. There was an awful lot of work involved for a simple prank or practical joke although that certainly is an option.

### *The Red Lion by Maria Orsi*

I picked the book up a couple years ago at a sale in a local occult bookstore. I haven't seen or heard of it before or since, but it cannot be completely rare, since it was printed at least twice in the USA (1987 and 1992) and twice in Germany. Apparently it was a Book of the Month selection in its 1984 German edition. In any case, I may quote extensively from it since I think it is an important book, and none of my acquaintances seems to have heard of it.

The author, Maria Orsi, appears to be better known in Hungary, as I could not find a reference to her in the materials I have at hand. She originally wrote the story during the "fire and hell of World War II" according to the back cover copy. "After the way, it was published in Budapest [A Vörös Oroszlan, 1946] but was soon banned by the government."

The U.S. publisher was "Computer Composition Co." in Nashville, Tennessee. I found that pretty interesting in itself, that this excellent book be brought out by such an obscure publisher.

It is a real treat to read the work of a writer so in command of her craft as Orsi. Even if considered strictly from a "literary" point of view (whatever THAT is), this book is a pleasure to read and deserves to be better known. (I suppose I am also complimenting the translator and editor, but I have no way of knowing what part they played in this production.) Orsi has read deeply and intelligently of the history, theory and practice of alchemy, and weaves historical facts in deftly with her stories.

The story starts in 1553 in Germany. Young, uneducated Hans Burgener by chance learns of alchemy and the Elixir of eternal life. He becomes obsessed with acquiring it, leaves home, and by chance encounters and attaches to an alchemist who (he discovers) possesses the Elixir. The older man, seeing the whole

situation, realizes that to give it to the spiritually undeveloped Hans would be a mistake. Hans, however, in desperation kills him to steal it. Hans still dies a horrible death—a result of the very thing he killed to steal—and is reborn with the knowledge of his awful crime.

In a later incarnation under the name of Burrhus, he has transcended his more base animal passions, but yearns still for the secret of eternal life. After many fruitless experiments, he allies himself with a dark force called "Homunculus" in the novel. This soulless, semi-eternal entity tells Burrhus that it possesses all the knowledge needed to perform the Great Work. The alchemist's greed and desire cause him to ally himself with this monster only he can see. Together, they exploit wealthy but stupid kings and queens, and dissipate their resources without coming nearer to the Magistry. Finally he frees himself of the Homunculus' bond, but his life force is almost spent and he dies quietly at age 79.

In his next life as Louis de la Tourzel (b. 1700), he was kinder and more intelligent. He had money, and lived in Paris in comfort. Through acquaintances in an odd ecstatic religious cult, he met and married the girl who was to be his downfall in this life. She was the embodiment of everything irresistible about sex: insatiable, remorseless, and totally devoid of conscience. Tourzel's willpower was not equal to the challenge and she basically dragged his life force from his, an orgasm at a time. When he had no more to give (and even long before) she would betray him with whom-ever she fancied, even in their own house. The following quote gives an example of Orsi's command of her characters.

"I should have put Corinna away, banished her. Nobody who has never been overpowered against his better judgment will ever understand why I did not do just that. Part of me longed to be free, but the other part was a slave. My violent, trembling passion made me a prisoner on the astral plane, bound by Corinna's bewitching loins. In the same manner, Burrhus had been imprisoned on the deepest plane of matter by the alliance with Homunculus.

"I can't even say I believed Corinna when we acted out our farce of a reconciliation with tears and promises. No, I knew and understood what was happening in and around her, and I despised her. But, though I could not leave her, I could not keep myself from striking her again and again in my futile anger. I beat her and dragged her around by the hair. I, who had never before imagined I could hit a woman. But the more I beat her, the more humbly she crept back to

me, and the more she conquered me with her body. Nothing made her happier than to force a man to succumb to her against his will and take her in a blind passion of lust.

"It was the dark side of Eros that took possession of her now. She no longer sought the straightforward pleasure of young, strong bodies. What attracted her was the depraved and bizarre, the rotten and perverse, the tragic and the dangerous. I saw what was happening to her and knew I could not save her...."

"I would leave her and find I had to hurry back. I would rush into brothels to barricade the memory of her body with other women—only to find that in the instant of climax I called her name..."

"The more often and more deeply I fell, the more indestructible was her demon's power over me, despite what I knew about her. Not only did it control my physical body, but my astral world as well, where my passion made it more powerful. The composite being created by my astral passion did not even have Corinna's lying beauty, it was an obese reptile with bulging eyes, covered with the slime of self-centered lust. Only the perversion of sexual excitement could make it seem desirable even for a few minutes.. Yet the monster grew continuously from our sinful gushing of sperm and tainted blood from which no life could be born. For Corinna's womb was barren.

"People don't really understand the mystery of blood and sperm, They think that when this awesome oil of the lamp of carnal pleasure is expended on a barren, goading passion, it overflows the circle of the obsessed lovers without consequence. Actually, a dark life springs from each dark ecstasy. The diseased and debauched loins produce succubi and incubi—those elemental, astral vampires who visit the lonely beds of troubled adolescents, frightened virgins, longing widows, and perverts and drain their strength in the hours of sleep and loneliness.

"The priests of the black masses knew this. It is said that one of them performed the infamous "sperm mass" for Diane de Poitiers, conjuring a hideous demon who was bound to obey his parent and conjurer. This is supposed to account for the young Henry II's obsessive love of a woman old enough to be his mother."

This passage indicates something else to ponder. The protagonist in this novel, in all his incarnations, is male. It seems to me that Orsi has a very deep understanding of male psychology and sexuality (assuming you agree that there are such things).

Finally, the protagonist is born a last time. He has been purified by the fires of passion and washed clean by the waters of love and knowledge. His parents are initiates in what appear to be a secret Rosicrucian lodge, very similar to the "FOCG" described by Franz Bardon in his novel (more comments on this below). He successfully undergoes spiritual examinations and is initiated into the Inner Circle of conscious humanity.

It is difficult for me to read about these lofty spiritual concepts with avidity. However, I salute the author's sincerity, since she is trying to uplift and instruct without becoming a tiresomely didactic. This probably simply a reflection of my own lack of spiritual development. In summary however, I unreservedly recommend the book to anyone interested in alchemy, the Rosicrucian legends, spiritual development, or even to fans of just plain excellent writing.

### *Bardon and Orsi?*

Now I enter into the realm of pure speculation. It was interesting that Orsi wrote in 1946, ten years before the publication of Bardon's first book. Orsi was Hungarian and Bardon Czech, but the countries are very close together, and the theme of Orsi's book is strongly reminiscent of Bardon's writings...

### *A note about Venus*

I was reading the article in the Encyclopedia Britannica about the planet Venus and thinking in my mind how different the physics of that planet are compared to the classical conception of Aphrodite/Venus. The surface temperature is above the boiling point of lead and tin, and the clouds that enshroud the planet are 80% sulfuric acid. The atmosphere is almost completely composed of carbon dioxide, with a bit of nitrogen and suspended vaporized chemicals and metals. It is definitely an inhospitable place, as there is no terrestrial life (not even cockroaches) that could survive on Venus' surface for more than a second. Finally I reached the end of the article and was surprised to see this comment:

"Astonishingly hot, with an oppressively dense atmosphere containing corrosive gases, with a surface glowing dimly by its own red heat and characterized by bizarre optical refraction effects, Venus (curiously identified in ancient literature with Lucifer) seems very much like the classical view of hell." The authorship of the article was credited to "C.Sn./A.S./Ed." where "C.Sn." is no other than our old pal Carl Sagan.

*(Continued on Page XV)*

# The Philosophers of INTERNETure

*by Russ House*

In my work, I am responsible for finding ways to use technology to help businesses attain their goals. Generally, these technical solutions depend on computers in some way, usually involving a number of computers that are able to exchange information, or to share the same information. The intent is for people to have new insights and realizations, or make better choices because of information that is available.

Like everyone, I have seen the increasing number of articles on the Internet, and at some point in the past, have said 'So what'. I had no particular urge to 'surf the Net'. After almost 25 years in the business I had managed not to own a slide rule, or pocket protector, and found that I got along with more CEOs by pretending to be as uncomfortable with computer jargon as they were.

Things changed. I surf. It's good. This is how it happened.

Many of you have heard of America Online, and CompuServe. Along with Prodigy, these are the largest commercial online services for consumers. At present, CompuServe has over 3 million users, and AOL has about 2.8 million. After I upgraded my home PC, I decided to try this sort of service, and in time had accounts on America Online and CompuServe. These are so widely promoted today that PC magazines often come with disks to load on the computer to start a free trial account. A PC that will run Windows or a Mac, a modem and a phone line are all that is needed. These tools are friendly enough that a slide rule is just in the way. Get an espresso machine instead and stay up all night. The rates are generally cheaper than.

In time I found that there were forums for all sorts of special interests. I spent lots of time on CompuServe initially, and looked for information on esoteric topics. Their New Age Forum offered lots of interest. I found people to exchange ideas with, read messages that people posted, and scanned the libraries of documents that people contributed. From time to time there would be some discussions on alchemy, but little sustained interest.

In 1995, Jean Dubuis visited Winfield for a meeting with the board of The Philosophers of Nature. There was no time to arrange for a conventional lecture, so I asked Jean if he would be willing to try an electronic

forum on CompuServe. Jean agreed, and with Patrice as interpreter, and with me as a typist, we managed to conduct a brief forum. Due to problems in promoting the forum due to their being only a few days notice, there were few people attending our forum, but the possibilities became apparent to Jean. He now has a computer, but is not yet connected to such a service. Since January, 56 people have retrieved a transcript of the forum to read on their home PCs.

Also, 120 people have loaded the 1st course of The Fundamentals of Esoteric Knowledge, and 56 have read the Introduction to this course. There are no plans to put further courses online, as this was done primarily to gauge the interest in these topics by CompuServe subscribers, and to promote the organization. The same course material has been made available on America Online, and has received similar attention.

The Philosophers of Nature can be reached via addresses on America Online: Ken Miller can be reached via "StonePON" and I can be reached at "Maj R Cana". Internet formats for the above are StonePON@aol.com and majrcana@aol.com. In fact, this article was sent through electronic mail from my PC to Ken's.

Recently, I arranged for Internet access from my home through a Chicago provider. As a result, I have spent many hours 'surfing the Net' and have been amazed by the massive amount of information available through this worldwide computer network, with well over 30 million users. In my searches for alchemical wisdom, I was generally disappointed until a few weeks ago, when I found the 'home page' created by Adam McLean.

Adam, as many of you will remember, was the publisher for The Hermetic Journal, now discontinued, which was devoted on Alchemical, Hermetic and Rosicrucian topics. He also brought out a fine series of limited edition books, which are highly sought after. Today, Adam has created a very interesting 'home page' on Alchemy.

To get to this, and the many other home pages of the Internet, you need special software called an Internet browser, such as Mosaic or Netscape. Connecting to the Internet through your provider, usually through a modem, you type in the location for the home page, or

use a 'search engine' to look for everything with the word 'alchemy'. The home page appears as text, attractively formatted on the page, with pictures. Some of the words and phrases are underlined and appear in a different color, which indicates that one can point to them with the mouse on the PC, click on them, and you will then be able to view another document. In this way, one can navigate the more than 200 pages of the Alchemy Home Page.

Among the offerings are complete transcripts of various ancient Alchemical and Rosicrucian documents, including the Fama Fraternitatis, and The Chymical Wedding of CRC. Here, one can find Indexes of authors of alchemical books and symbols from numerous alchemical books, such as The Twelve Keys of Basil Valentine. Lists of publishers and of recent books on alchemy are also included. An electronic mail, or Email forum has been created by Adam to allow interested people to interact and exchange information and ideas. To join, send an Email message to [alchemy-forum-Request@colloquium.co.uk](mailto:alchemy-forum-Request@colloquium.co.uk), with the word 'Subscribe' in the message. To stop receiving mail, send a message with the word 'Unsubscribe'. Users of most commercial online services should be able to participate in this forum.

When I wrote to Adam, via Email, he indicated that he

was willing to include information about The Philosophers of Nature on his home page. I developed some information about the organization and the courses it offers, and sent it back via Email. In just a few hours, The Philosophers of Nature was on the Internet, thanks to Mr. McLean's generosity, and genuine devotion to providing information to those who are seeking regarding the alchemical path in its various aspects. We are pleased that we have been granted a place on a 'web site' that will be an electronic gathering point for persons interested in Alchemy world wide. Because of this, within three days of placing our information on the Internet we had an English-speaking gentleman in Germany inquire about membership and course subscriptions. Since that time we have had four additional inquiries. Adam, we thank you.

The Alchemy home page is located at:  
<http://www.colloquium.co.uk/alchemy/home.html>  
 The Philosophers of Nature:  
<http://www.colloquium.co.uk/alchemy/Philnatr.html>

When economically feasible, we would like to create our own 'home page'. I am interested in any information regarding organizations that would donate space to us, or which have reasonable rates to maintain a page.



## A Note... continued from page VIII

The big question at the end of the trip was "Where do we go next and when?" Suggestions were given to visit Italy, Portugal, Greece and Spain. Another suggested that we retrace one of the pilgrimage routes from Paris to Spain, as did Nicholas Flamel. Tamara has agreed to communicate with us and to help in arranging for another trip.

This was the first Philosophers of Nature tour. As with all 'firsts', it was an experiment to see if it could be done, what could make it better, and to see if people want to do it again. We now know that it can be done and at a very reasonable rate, we have numerous suggestions for improvements, and 90% want to take another trip as soon as possible.

If any of you have suggestions regarding alchemical and esoteric places to visit, please write to me and tell me why these areas would be of interest to those traveling the Path of Return.

With a full heart and many warm memories, I bid you 'au revoir', Sincerely and fraternally.



## Wine Spirits...

*continued from page IX*

take the distillate, redistill in balneum with a 500ml flask with 24/40 joints. You will see a distillate that some would say is reminiscent of another. Now try the same process with the equipment described in previous articles. Would anyone like to hear of the spagyric works to be done on fresh plant juices? Let us know what happens (i.e. write an article)!



## Red Lion...

*continued from page XIII*

Another interesting, and yet unexplained feature of Venus, is that at every inferior conjunction it presents the same side to the Earth, and is thus somehow gravitationally influenced by our planet. This is suggestive from a metaphysical point of view.

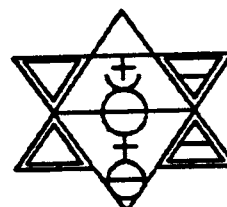

# A Light/Sound Machine Special from Triad

We have been following with interest the research conducted on light/sound (L/S) entrainment devices, also called 'brain machines' and have selected a fine line of products that we recommend to our friends who are interested in experimentation with this interesting technology. Guarantee: Machines can be returned within 30 days for any reason; lifetime warranty.

**The XCELR8R II** is the first portable L/S system that links directly to a PC. In terms of price and versatility, we believe this is the finest unit on the market. Easy to use.

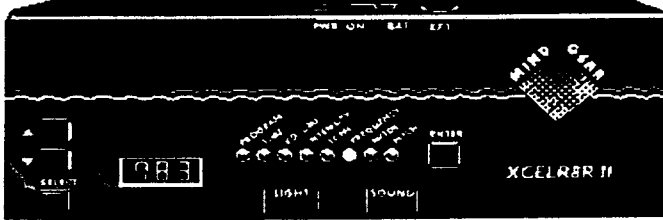

## The Mind-Gear XCELR8R II

**\$349.95 list. Your price through 10/1/95 \$325.95**

## The Mind Gear PR-2X

The PR-2X has many of the features of the XCELR8R II  
**\$269.95 list. Your price through 10/1/95 \$249.95**

The XCELR8R II and the PR-2X have these features:

- 50 preset sessions with adjustable run times
- 4 sound possibilities including Binaural beats
- 6 modes of synchronizing light with sound
- Manual control to allow for experimentation
- Superbright glasses with 4 LED's per eye
- Ready for 2 users (need extra glasses and headphones)
- Rechargeable battery with charger - very portable
- Stereo input to allow listening to CD or tape player
- One set of quality stereo headphones are included
- Carrying case to protect the unit when traveling

The XCELR8R II has these additional features:

- Headphones upgraded to digital quality
- Attache-type carrying case for portability
- Cable/connector to interface for IBM-style PC
- Software to create, graph, edit and store sessions

**Extra glasses for above systems: \$35.00**

**Extra headphones for PR-2X: \$25.00**

## The Mind Gear SLX - \$149.00

**A low cost system modeled after the PR-2X.**

- 16 built-in pre-programmed sessions
- Adjustable pitch
- Adjustable run time (15-90 minutes)
- Frequency control (1.0 to 40.0 Hz)
- Superbright red LED glasses, 2 LEDs per eye
- Stereo input for CD or tape player
- Manual control of settings for experimentation
- Stereo headphones
- Runs on 4 AA batteries (not included)

**Rechargeable battery version \$179.95**

**Attache-type carrying case \$20.00**

## L/S Turbocharger - \$299.95

**\$195.00 when purchased with a L/S system**

Adds CES (safe microcurrent electrical pulses) to any L/S device. Includes battery, gold-plated earclip electrodes & connector kit. Interface unit has intensity control. Synchronizes with lights.

**CAUTION:** Please assume that all L/S products have only experimental status. If you have a medical condition, please consult with an authorized health care provider before using these systems. Those people who have any type of seizure disorder (epilepsy, etc.) must exercise extreme caution when using any form of pulsed frequencies. Certain frequencies can trigger a seizure in those with pre-existing conditions. Pregnant women and people with heart pacers should also consult with their doctor before using our systems. You must exercise caution if you use this equipment while under the influence of medication or drugs. L/S machines are not medical devices.

**We accept Visa and MasterCard.**

Fax your order for faster service

Allow up to 20 days for delivery.

**All returns subject to 15% restocking fee**

**Shipping in Continental US:**

XCELR8R II and PR-2X : \$14.00 per unit

SLX and Turbocharger: \$8.00 per unit

# TRIAD

**125 West Front Street, Suite 275, Wheaton, IL 60187 USA Phone/Fax 708.665.1417**

We supply herbs, essential oils, minerals, and labware for the Alchemical researcher



*He's back!*  
 (THE LAST GREAT ALCHEMIST IN PRINT)

# ALCHEMICAL WORKS: Eirenæus Philalethes Compiled

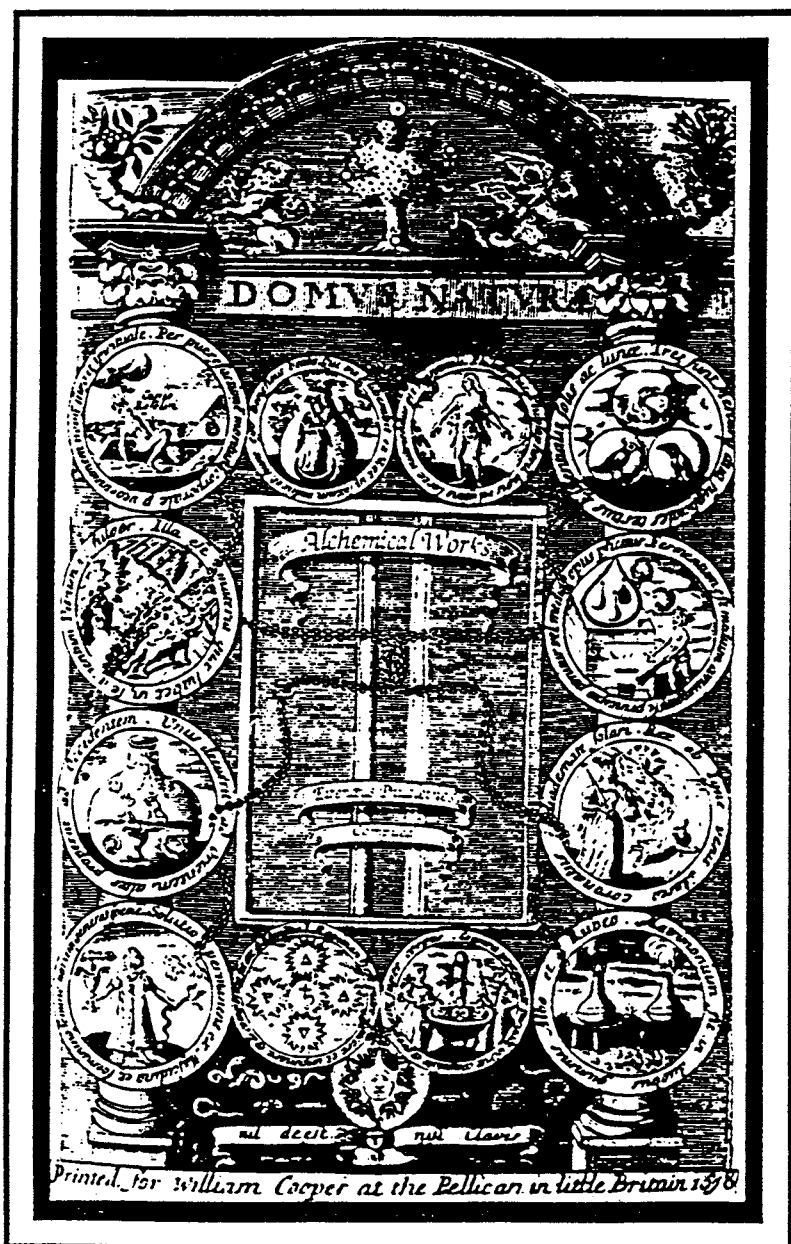

hard cover 592 pages indexed a.f.p. ISBN 0-9640067-0-7 \$60.00

\$65.00 U.S. Postage paid to:

**LPN-USA**

Box 11218

Boulder, CO. 80301

Eirenæus Philalethes, mysterious alchemical adept of the seventeenth century has elicited intrigue, study, and controversy for historians, littérateurs, and scientists since these works were published beginning in the mid-1600's.

This volume is unique. It is the only to contain all Philalethes' works currently available in English, and it is indexed.

Original format has been carefully preserved throughout, offering readers access to complete, authentic, and legible text and content for their enjoyment and studies, without having to resort to the microfilm copies previously available to most readers as the only source for much of the text contained within.

The practice of alchemy has been perennial for all of written history, woven through one civilization and into the next, often tying them together. It is a science, a philosophy, a mystery, and a quest. The very word connotes a magic transcending our limited beliefs about the laws of nature. It was used as a tool of charlatans, who did much through their deceit to destroy the reputation of the science. Much more often it has been a field of study for great minds. C. J. Jung spent his last twenty years illustrating its value in framing the workings of the subconscious through alchemy's rich use of metaphor. Sir Isaac Newton poured over Philalethes' tracts, finally preparing what he thought to be *Philosophic Mercury* in 1675.

The essence of alchemical writings has been consistent through the centuries, while the details have been inscrutably and defiantly deceptive. Philalethes is called the last great alchemist in print. This collection presents a treasure map for many uses.



*Only a few copies left!*

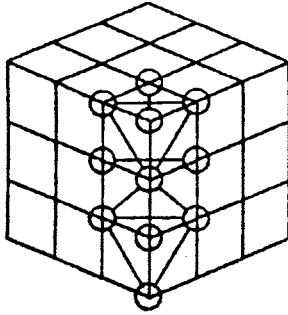

*"In the study of Qabalah there is no more important glyph than the Cube of Space..."*

Paul Foster Case

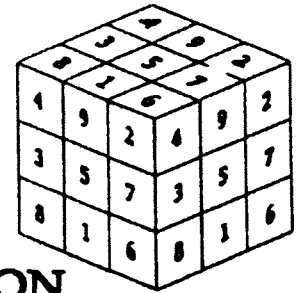

## THE CUBE OF SPACE: THE CONTAINER OF CREATION

a book by Kevin Townley

Topics include:

- \* Generation of the Cube of Space through geometry.
- \* The Magic Square of Saturn.
- \* Relationship of the Cube to the Tree of Life.

\* Placement of the Tarot (Minor Arcana) on the points of the Cube.

\* The Cube's relationship to the Macro and Microcosm.

\* The Cube of Space in the Four Worlds.

To order send \$45.00 plus \$3.00 for postage to  
Archive Press, Box 11218, Boulder, Colorado 80301.

*"As Above, So Below"*

*When you understand the process of Divine Creation on the macrocosmic level, you can apply those same principles on a personal (microcosmic) level!*

## The Philosophers of Nature unveil...



# *The O.R.A. Project*

OCCULT RESEARCH & APPLICATION

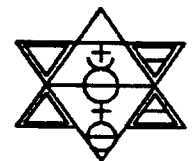

P.O.N. has for the last few years maintained a research group to work on various laboratory alchemy projects. Now we wish to form a group of those members who are interested in participating in research projects involving magic, kabbalah, and various other occult subjects.

If this interests you, please send a self-addressed stamped envelope to: Ken Miller, 405 West Washington Street #314, San Diego, CA 92103; or e-mail Ken at StonePON@aol.com (You will receive a questionnaire that will allow us to assess your interests and talents. Any suggestions for research projects will be cheerfully considered.)

**WANTED:** The ORA project is looking for an English or Hebrew copy of The Book of the Angel Raziel (Sepher Raziel; also titled Raziel ha-Malach). An English translation is known in the British Museum: Sloane No. 3826. If you have a copy or translation please contact the ORA project. Thank you.

# ORA ET LABORA

Vol. 2 No. 2

Copyright 1995, The Philosophers of Nature

July 1995

NEWS FROM THE PHILOSOPHERS OF NATURE RESEARCH GROUP

## THE EDITOR'S CORNER

by Russell House

**We need to talk.** Do you want some seminars or lectures in your area this year or next? Sue and I have certainly enjoyed helping to arrange for events in the past few years, and we are willing to continue to support these very valuable ways of exchanging information and techniques on Alchemy and other esoteric paths.

Your feedback is very important to us, because as members, this is your organization, and our job is not to direct and control seminars, but more to help create the sort of events that our members need.

Since 1992, three major seminars and two or three smaller events which involved instructors from LPN in France have been held in the Chicago area. This is in addition to some public lectures and spagyrics classes which I presented. Since we live in the area, it is certainly easier for us to arrange for facilities and to find local volunteers to help with some of the necessary work. We think that our membership in the Chicago area has grown to some extent because of these seminars and events, and it becomes easier to find volunteers. It would be easy to use this to justify making the Chicago area a sort of center, as it were, for events.

Our interest is in the membership as a whole, not just in the members in our area. We are going to be looking at several options for a seminar to be held in another location. Based on discussions with Kevin Townley, we would consider Colorado as the next location for a major seminar.

We are taking steps to expand the membership of the organization, and realize that lectures, seminars and

workshops are an important way of making contact with prospective members, and to help our existing members to derive more benefits from their studies. To this end, we are going to look at where our members are located to start improving our advertising in these areas, and to consider having public events in these areas.

We can analyze until our minds are full of facts, but we need the perspectives of our members to get the real picture. It could be that you are the sole member in some tiny community that isn't on the maps, but there could be, for whatever reason, a fair amount of local interest in the topics our organization teaches. We want to know that. We don't need to concentrate on New York, Chicago and L.A., we want to go to the places where there is interest in our work.

### **This is what you can do to help:**

If you are willing to make arrangements for a local public lecture or weekend workshop, (arrange for local advertising and suitable location, and act as local contact for directions) please let us know. There would be no personal cost to you - just your time and effort.

If you know of newsletters and local journals with a good distribution that are read by people with esoteric interests, please send us a copy.

If you know of people who are interested in Alchemy, Qabala, or in Western esotericism, please offer them a copy of The Stone, or suggest that they write to us. Nothing is more valuable to us than your recommendation to a friend. This is the best advertising in the world!

Thanks.

This treatise on the acetate work with lead is considered to be the best of its kind by Jean Dubuis. He has mentioned the work in various seminars, most recently at the one in Paris. We thought that you might like to examine it here in *Ora et Labora*.

**Preparation of Saturn which is efficient against the Lepra of human & metallic bodies, and of which an oily solvent can be made by Violett-le-Duc, from his *Mineral & Metallic Medicines***

**D**istill a large quantity of good vinegar, till you have a cask full of it, because it is the basis and the foundation of this Work. To strengthen it more, distill it several times over the feces, then mix everything you have distilled with as much other non-dephlegmatized vinegar, and let them go over together, so that the distillate will become all the more efficacious. The dregs that remain at the bottom are put in a retort over a good fire by means of which one can extract an excellent oil from them, which can burn of its own and dissolve all kinds of minerals.

**A**fter preparing this solvent, take 80 lbs of powdered litharge - and not white lead or minium of lead calx, as several artists do, especially Isaac Hollandus. Take, I say, this litharge and put it in several big and very strong flasks. Pour on it as much of your vinegar that it will overflow by 6 fingers' breadth, and then put it on an ash-fire. Extract the salt of ☿ by a slow digestion, and on the feces that are left after the extraction of the salt and the crystals, pour one more the same amount of menstruum as indicated above. Continue doing this till all your litharge has turned into crystals which are, properly speaking, what the philosophers call the *Chaos* or the metallic *materia prima*.

**O**n this crystalline substance, again put for the last time fresh distilled vinegar. Dissolve it over a slow fire and filter it, so as to obtain a perfectly pure and flawless menstruum which, after passing through the steam-bath, will leave a substance that melts like wax at the bottom of the alembic. It hardens in the cold as it

melts in the heat. Thereafter, divide this melting substance among several alembics and little by little pour fresh menstruum upon it, as if to feed and water it only. Do this by first pouring on only two drops, then three, then five, then seven, increasing the amount in this way till the materia does not absorb any more. You will recognize this when you see the solvent coming out as acid as it was at the beginning. Therefore, whenever you distill your imbibed materia, take care that you continue till the phlegma is as acid as before, because this is how the child refuses the nurse's milk when its stomach is full. When the materia has been prepared in this way and converted into an excellent and precious gum, digest it in the steam bath for 30 or 40 days, till it becomes black and has a bad smell like that of liquid pitch. It is from this liquid and black pitch that you must extract, by the same bath, an excellent phlegma which can serve as a proper menstruum for extracting a precious salt from calcined earth, as we will write later. Owing to the continual distillation that you will make of the said pitch on sand, and by finally giving a strong fire above and below through the usual degrees up to a very violent fire, you will extract a red and quite thick oil which, together with the preceding distillations, will constitute as strong and violent a water as that extracted from wine, and will have the same great power. The philosophers call it water of life (brandy) of Saturn. Its substance is so pure

3

and subtle that it must be kept in a well closed vessel lest it evaporate.

To complete the perfection of this solvent, this water of life of Saturn must be put in a gentle bath, in a long-necked alembic, where the purest spirit of this water will rise imperceptibly till you see the appearance of some lines and filaments through the glass of the head. It is an infallible sign that all of the spirit has risen, and you must therefore stop this distillation and extract this first precious spirit. Preserve it carefully in a cold place and in a well sealed container. After this spirit, a milky phlegma will appear in a stronger bath. It will be much better for washing your calcined materia than the first of which we spoke above. Finally, by a stronger degree of fire, and after changing the receptacle, you will still separate an ardent spirit which will first come out white and watery, then red and oily, but it will be heavy and lie at the bottom of the receptacle.

However, if you wish, you can make it go over with a stronger fire.

In regard to the earth or the feces that are left at the bottom of the retorts as a black powder, they can also be dissolved with some fresh distilled vinegar and thus turn into new lapilli of a sticky and gummy consistency, and finally, by means of the above mentioned digestions and distillations, into wonderfully active and burning spirits. There are some who divide this earth into two, but although Isaac (Hollandus) himself adopts this division, I am nevertheless of the opinion that the best and shortest method is to calcine all the earth together and to reverberate it by a gentle



## ORA ET LABORA

flame till it becomes yellow like ochre. When this earth has become yellow due to the cohobation of the phlegmas, the salt can again be separated from it, according to the ordinary rules and operations of the Art.

Having achieved the extraction of this rare and precious salt, take the first salt which you have little by little extracted and which you have preserved. Pour it on 1 oz of the last salt, repeating this imbition till 1 oz of this salt weighs 3 or 4 oz and has retained the weight of the sal ammoniac of this spirit, till finally the volatile exceeds the fixed. If you work this process exactly, you will find an excellent earth at the bottom. Sublimate it in a very clear and well sealed glass vessel, and you will have the pleasure of seeing the sublimation of a Philosophical Mercury in the form of a fine talc, which you must keep as a most valuable substance.

To crown this work, take 1 part of this Mercury and add it to 4 parts of the above-mentioned spirit or to as much ardent spirit to make of them a solvent for the Sun and the Moon, such as the philosophers imagined were capable of turning them into spirit without destroying their bodies or losing their characteristics. Therefore, wonderful works can be made with this truly philosophical solvent, both for the health of human and metallic bodies. It can even be made with coral and litharge, and in that case you will without doubt make the finest and most harmless of all solvents.

## An Antidote for Rumors

There are numerous rumors about the LPN in Europe and the health of Jean Dubuis which are causing concern among our members. We wish to avoid becoming a party to the difficult political situations in France, but feel that we must offer our members the facts of the situation so that they can avoid any unnecessary worry.

LPN France is under the legal administration of a court appointed overseer to make certain that a new and legal election is held to establish a board of directors. At present, Marc-Gerald Cibard is the president of the LPN, maintaining control of the funds and the day-to-day activities of the organization, and distributing the lessons and newsletter. Marc-Gerald was asked to resign as president of the organization on numerous occasions, and has resisted complying with the wishes of his fellow officers. As a result, the officers have resigned, with the exception of Etienne Cornaille and Patrice Maleze. Until such time as a recognized board is established, The Philosophers of Nature does not recognize the organization in France, although it still maintains amicable relations with many of the individual members there.

Jean Dubuis, the Founding President of LPN, resigned from membership in that organization. Jean is a life-member of The Philosophers of Nature in the US, and accepted a position as Delegate to Europe for our organization.

The Philosophers of Nature, Inc., is the legal owner and has exclusive rights to all English language translations of the LPN lessons, having been given such directly by the author of the courses, Jean Dubuis many years ago.

In a recent journal of the French LPN an article was published which was written by Jean's son, Dominique. The article stated that Jean was sick and insane, the victim of heavy metal poisoning. As a result, the article said, Jean was not fit to take care of his own financial affairs.

Jean is involved in lawsuits against Marc-Gerald Cibard, and against Dominique. The emotional turmoil surrounding these suits, and the potential disintegration of LPN, an organization which he created in 1978, has aggravated Jean, and has caused some flare-ups of psoriasis. His general health is fine, and his mind is as sharp as ever. He gave a fine lecture in Paris, and, as is normal, did so without use of notes. Jean is presently writing a new course on esotericism with interesting information and techniques, which we believe will be the finest contribution of Jean to date. He continues to work on new electronic circuits and showed us a working prototype of a machine which was in the 'thinking' stages just 5 months ago. In fact he produced it just on schedule as he predicted in January. In conversation, Jean is as witty and astute as he normally is, and shows a presence of mind that anyone would enjoy having at his age.

Please feel free to share these facts with anyone that you believe would benefit from them.



## "Who Do I Contact When..."

I have questions about my membership?"

I have problems receiving my lessons?"

I would like to subscribe to The Stone?"

I need back issues of The Stone?"

Write or call the administrative headquarters: Philosophers of Nature, 125 West Front St., Suite 263, Wheaton, IL 60190; Phone (708) 665-1417 between 9am & 5pm Central Time, Monday through Friday.

I have an article or letter for The Stone?"

I have advertising for The Stone?"

Write, call, or e-mail the editor: The Stone c/o Ken Miller, 405 West Washington Street #314, San Diego, CA 92103-1994. Phone (619) 528-4521 (keep in mind Pacific Time). E-mail: StonePON@aol.com

**Please Note: MAILING YOUR INQUIRY TO THE WRONG ADDRESS COULD DELAY MATTERS FOR MONTHS.**

### • About The Stone

The Stone is published three times a year in March, July, and November, primarily for the benefit of the membership of the Philosophers of Nature. We hope to get members' feedback regarding what they would like to see in it. Articles, photographs, drawings, letters to the editor, and comments from members or others are solicited for submission to the Editor for evaluation. Submissions and advertising should be sent to The Stone c/o Ken Miller, 405 West Washington Street, Suite 314, San Diego, California 92103-1994. E-mail may be sent to StonePON@aol.com. Deadline for submissions and advertising are as follows: February 20th for the March issue; June 25th for the July issue; October 25th for the November issue.

### • Advertising

The Stone accepts advertising for both display and classified ads. Rates are as follows: Full page: \$100.00; Half page: \$60.00; Quarter page \$35.00; Classified ads are \$0.10 per word. For more information write the editor, Ken Miller at the address listed above, or e-mail him at StoneLPN@aol.com

### • Subscription to The Stone & Membership Information

The Stone is included in the cost of membership. Non-members may subscribe at the rate of \$20 per year (three issues). Subscription requests and any questions about membership should be sent to the administrative headquarters: Philosophers of Nature, 125 West Front Street, Suite 263, Wheaton, IL 60190. You may leave a message for the office manager at (708) 665-1417 from 9am to 5pm Central Time.

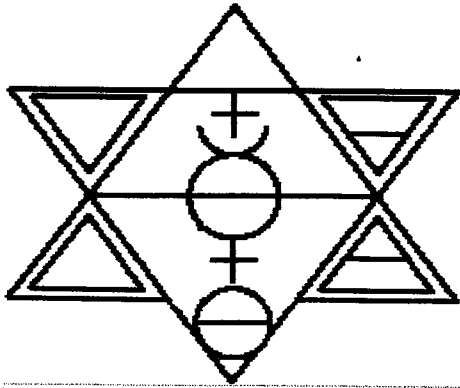

# The Stone

& ORA ET LABORA

Journal of The Philosophers of Nature

Issue Number 14

November 1995

## News & Notes from the editor

Welcome to another issue of The Stone and thank you for taking the time to read it. I hope you will find at least one gem hidden within its contents to make it worth your while.

### Conferences:

A lot has happened since the last issue, The Rosicrucian Enlightenment Seminar in the Czech Republic as well as a weekend PON seminar in Chicago featuring Jean Dubuis. Joe has written an enthusiastic report on the Czech experience starting on page two; I found the Czech conference an "ordeal of wakefulness" (as one attendee put it), the opportunities to talk to so many people kept many of us from grabbing more than a few hours of sleep a night. What surprised me most about the gathering was the huge number of Americans that came. While there was certainly an international attendance, by my unofficial reckoning at least 85% were Americans. I'm not sure what that means exactly, perhaps only that we are affluent enough to indulge in such a conference. Another curious fact is that as far as I could tell, there was only a handful of lab alchemists attending (all PON mem-

bers, I think). And it's hard to talk about Rosicrucian history without also talking about the laboratory alchemy that often went hand in hand with it. Since none of the speakers had any lab work experience, our President, Kevin Townley, was asked to give the lab alchemist's perspective on more than one occasion.

If, as Joe says, the Invisible College did become visible then we were, most likely, the freshman orientation class. In future issues we will report on more of the subject matter that was presented.

The Chicago weekend was a more intimate gathering; and because it was (by necessity) put together very quickly there was not much time to promote it or much time to plan for it so I know several people who would have liked to attend were unable to. *[I'm happy to report that we (The PON Board) are developing a couple of great conference ideas for 96-97 that you will hear about in the next issue of The Stone.]*

While all of the seminars/lectures in Chicago were good, a couple of them bear special mention: Sue House and Lisette Dessureault led an interesting discussion on Women & Alchemy. Those of you who have read *Alchemists and Gold* know that most of

*(Continued on Page IX)*

### In This Issue...

News and Notes	page 1
The Moment The Invisible College Became Visible	
<i>by Joseph Caezza</i>	page 2
Hermeticism and Esoteric Islam	
<i>by John Eberly</i>	page 3
The Sign Of The Cross	
<i>by Mark Stavish, M.A.</i>	page 8
Spiritual Implications of Nuclear Power	
<i>by Adam McLean</i>	page 9
The Tarot: Structure and Use, Part One	
<i>by Ned Darenuith</i>	page 10
Advertisements	pages 16-17
ORA ET LABORA	pages 18-21
About The Stone	page 22

**The Stone, Issue Number 14, Nov. 1995.** Published in March, July, & November by the Philosophers of Nature. Editor: Ken Miller. Subscription details on page XXII. © 1995 Philosophers of Nature.

# The Moment The Invisible College Became Visible

*By Joseph Caezza*

1995 will be remembered as the year of my divorce, after being married legally for only four months. It was a failed experiment, a chemical wedding of violently exploding consequences. When first reading about the Rosicrucian Enlightenment Revisited conference announced in the Spring issue of *Gnosis*, I experienced a revival comparable to the rising sap in the silently thunderous sprouting of sunflower seedlings in my window sill soil. The anticipations, expectations and fiery enthusiasm emerging from the prospect of being part of such a happening nourished me through a summer of 70 hour work weeks. September finally came. In a state of professional burn-out, my goal was simply to arrive.

Contemplative insight informed me that some of my brothers from The Philosophers of Nature would also attend this conference held in Chesky Krumlov, Southern Bohemia, in the Czech Republic. Mark Stavish, whose brilliant article on "Kabbalah and the Hermetic Tradition" appears in the March '95 issue of *The Stone*, first crossed my path on a shuttle bus at the JFK airport. We soon connected with Ken Miller, editor of *The Stone*, at an airport restaurant amid the strange but joyous feeling that this accident was somehow planned.

I first met Ken in 1990 at the home of Hans Nintzel on MelROSE Drive in Richardson, Texas during the occasion of Manfred Junius' alchemical class. Our second meeting in 1993 happened at the Wild ROSE girl scout camp outside Chicago for an alchemical workshop that featured prominent members from the then French branch of The Philosophers of Nature. A perfectly consistent destiny brought us together a third time at a conference on the Rosicrucian Enlightenment held at a Jesuit monastery now converted into the Hotel RUZE. The symbolic five petaled rose so prolific at the Hotel Ruze, the village of Krumlov and her sister city, Prague, the veritable silicon valley of alchemy, has finally engraved itself on the fabric of our hearts.

We arrived at Krumlov's Hotel Ruze on a bright summer mid-afternoon. My only goal had been achieved. Now new sensory input from the adventure of exploring this superb medieval town of narrow cobble stone streets, 14th century castle and garden could clear a clouded mind and set the stage

for encounters with a stellar cast of scholars and fellow pilgrims from 17 different countries. I soon discovered that the river, Vlatava, meandered in a manner that almost completely enclosed this village and later learned that this earth form was interpreted as the tail-eating serpent, an alchemical symbol of ultimate significance.

That evening I became reacquainted with Kevin Townley, a former Carmelite monk, who recently attempted the procedure of animated mercury that lead Nicholas Flamel to the gold of the Philosopher's Stone. Kevin, now the president of The Philosophers of Nature, pointed out some of the key conference players as we strolled the enchanted starlit streets comparing notes on our ongoing personal laboratory work. We first passed Chris Bamford and later Adam McLean and Joscelyn Godwin. The INVISIBLE COLLEGE was for a moment to become an actual visible reality.

Nicholas Goodrich-Clark delivered the first lecture on John Dee's Bohemian mission with volcanic intensity. He even noted a Rosicrucian afterglow in Hesse's Nobel Prize winning novel, *The Glass Bead Game*, my personal all-time favorite. Joscelyn Godwin spoke on the medieval value of magical gardens and chambers of marvels as places of initiatic experience and contemplative ecstasy. Chris Bamford expounded encyclopedically on the symbol of the rosy cross. John Matthews once again proved his authority as our resident planetary grail expert. Adam McLean explicated alchemical imagery in the Rosicrucian context, valiant in his attempt to separate historic reality from myth. He continues his life long vocation of restoring appreciation for the best alchemical texts. Z'ev ben Shimon Halevi spoke on Kabbalah's history with electrifying wisdom. John Michell also commanded the high voltage presence of a man who Knows. Michell reviewed his research into pure number as the root of a single, universal code of knowledge. His vision touched me deepest perhaps because it echoed so strongly the thought of R.A. Schwaller de Lubicz. Evidence suggests that Schwaller was the original genius behind the Fulcanelli material, possibly the most significant alchemical literature of our century.

Robert Bly brought evening amusement with poetry focused on the theme of melancholia, a

*(Continued on Page XXII)*

# Hermeticism and Esoteric Islam

by John Eberly, © 1995

*"Ta'wil: To reveal the occult, to occultate the apparent."*  
- Henry Corbin

The idea of the Iman in Shi'a Islam, who is the pole of the universe, is closely related to the Sufi concept of the perfect master or *qtub*. In fact, the two are nearly identical and refer to the same essential Islamic reality, the *haqiqat al-muhammadiyah*. It is rare, however, when both Shi'a Imam and Sufi *qtub* come together in one person after 'Ali ibn Abi Talib (d. 661), the patron saint of Sufism and first Imam of Shi'a Islam. This was indeed the case with the unique Imam and *qtub*, Jafar as-Sadiq (d. 765).

Jafar was an accomplished alchemist and also the sixth 'Alid Imam who appears as a central figure in Shi'a, Sufi and Ismaili *silsilha's* or initiatory chains. He was a prolific writer who founded the *Jafari*, the Twelve Imam Shi'ite school of law which engendered the Twelve Imam Shi'ites ("Twelvers" or *ithna 'ashariyyah*). Jafar also wrote Qur'anic commentaries which include the concept of *jafr*, a way to interpret layered meanings of key verses that disclose prophecy and revelation through the numerical value assigned to the letters of the alphabet.

Imam Jafar as-Sadiq (1) had two sons, Ismail and Musa. Ismail died before his father, and Jafar then proclaimed Musa to become his successor.

Before his death, however, Ismail declared his son, Jafar's grandson Muhammed ibn Ismail, to become the next Imam. The followers of Ismail, in accordance with this declaration, after Ismail's death recognized his son Ismail, not his uncle Musa, as the seventh Shi'ite Imam. This group is known as the Seven Imam Shi'ites (Seveners, or *saba'iyyah*), better known as the Ismailis, who, despite their break with Jafar over his successor nevertheless continue to include him in their *silsilah* or chain of initiation.

The successors of Musa continued to lead the orthodox Shi'ite branch of Islam up to the twelfth Imam, who disappeared without trace and is still believed to live in occultation on the spiritual plane. He is the Hidden Imam, the *Ma'dhi* "who is guided" and who, it is said, will appear at the time to fill the world with justice. Access to this Hidden Imam is an internal affair potentially available to all believers who ascribe to his existence. In some Sufi orders, the identification of the *murid* with the *murshid* or the

disciple with the Master is analogous with this relationship in "Twelver" Shi'ism.

The Ismaili branch continued as a secret initiatory line which included extremist Shi'ite revolutionaries and mystics.

The most colorful and legendary figure, perhaps, is the infamous Hasan i-Sabbah (d. 1124), the Old Man of the Mountain, whose army of alleged hashish-smoking assassins terrorized the 11 century landscape from their mountain-top fortress at Alamut (Eagle's Nest). This Hasan's great-grandson, also called Hasan, proclaimed the *Qiyamat*, or great Resurrection, at Alamut on the 17th day of Ramazan, an annual month-long Islamic fast.

For Ismailis, the *Qiyamat* symbolizes the end of time and also the end of all religious law. Hassan on this day broke the chains of Islamic law and ordered all to break their fast with food and with wine, a substance expressly forbidden by the Qu'ran.

It is not hard to make a connection between the significance of this action taken by Hasan and the fulfillment of the duty of the Hidden Imam *who will appear at the end of time*. The Ismailis perhaps felt that the *Qiyamat* amounted to the manifestation of prophecy, and yet for the mainstream Shi'ite the whole affair amounted to a vile and contemptible heresy.

As to the end of Time: *"The Hour will not take place until two parties fight each other with one and the same aim."* (2)

-The Prophet Muhammed

Jabir Ibn Hayyan (b. between 721-730) (3), the disciple of Jafar as-Sadiq in Shi'ism, Sufism, and alkimia (Alchemy), foresaw Hasan's declaration of the *Qiyamat* when he described the Glorious One.

The Glorious One was said to be an expatriot come from afar who would require no long initiation or Master. he proclaims the esoteric meaning of the end of religion and the end of linear time with the announcement of Eternal Life, spoken in an *immaterial diction*. (4)

Sufi poets often use terms like "wine", previously mentioned in connection with the *Qiyamat*, to de-



scribe a spiritual substance with unique qualities, and alchemists use elliptical and often poetic terms to describe their processes. Both make use of multi-layered symbolic language to conceal a unifying and underlying teaching or truth designed to keep the literal-minded confused and at bay. This initiatory vocabulary, with possible roots in Jafar as-Sadiq's *jafr*, also serves to provide a non-linear point of departure into the mystic unknowing for the attentive recipient, in some ways much like the function of the *Qiyamat* in Ismailism.

The Ismaili interpretation of the general Shia use of *taqiyyah* or dissimulation involved the protecting of the sacred lore from profane ears and became an internal discipline supporting the hierarchy. The secret sacred lore was thus protected at every level from those not yet ready for further initiation into the Mysteries. Hermeticism of this sort exists in some Sufi forms of instruction in which the Master, aided or identified with the grace or *barakat* of God, guides the disciple through various stages and stations, a process which also often simultaneously unlocks the found in the initiatory aspects of al-Kimia. In each separate case, the initiate is aided by God and God's representative and Master and supported by texts which open first intellectually and then experientially.

In Jabir's work *The Glorious One*, (6) a version of *jafr* is used to describe the basis of what would become Twelver Shi'ism, the predominant Shi'ism in Iran today. By using Jabir as a reference point, Twelver Shi'ism considers itself to be a return to "primitive Shi'ism". Reflecting the same use of single letters as in the Qu'ran, the *Glorious One* begins with the letter 'Ayn, symbolizing in this system 'Ali; 'Sin, symbolizing Salman the Persian, adopted into the Prophet's household; and 'Mim, symbolizing Muhammed.

The order of the use of these particular letters and the human mystical counterparts which they symbolize clearly points to the preference and precedence of the Imam in Twelver Shi'ism.

That Ismailis to this day are considered to be heretics by orthodox Shi'ism, which in itself is regarded as heresy by most Sunni Muslims, puts them, by association only perhaps, in the path of the *malamatiyya*, the "people of blame".

Ibn 'Arabi (d. 1240) utilized the basis of *jafr* to examine the roots of the words of the Arabic language as it specifically applied to the vocabulary of the revelation of the Qu'ran. In a reversal of exoteric

reading and application his system reveals how root letters, words, and whole phrases have an opposite reading which hides other meanings and levels of understanding. Using the root of the word *kafirun*: *kfr*, which means "to hide" Ibn 'Arabi describes the highest level of the *malamatiyya*, God's saints that hide under the traits of his enemies. The label of *kufr* for the exoteric-minded is exclusively reserved for those most deserving of contempt.

Other Sufi mystics are mentioned in the Ismaili *silsilah* alongside Jafar as-Sadiq, such as Shams al-Din Tabrizi, and Jalalludin Rumi, the famous author of the *Mathnawi*, also known as the "Persian Qu'ran". (7)

Rumi, who was a disciple of Shams al-Din Tabrizi, and Ibn 'Arabi whose stepson Sadruddin Qunawi was a great friend of Rumi's, profoundly influenced the life and work of the mystic Fakhruddin 'Irqai. (8)

'Iraqi's initial connection with Sufism came from his association with a group of wandering *Qalandars*, another group of outsiders who by tending to disregard all outward socially accepted norms, brought down the wrath and indignation of the orthodox Islamic community. In reality, the *Qalandars*, and the *malamatiyya*, who must be viewed as the apogee of the blameworthy ones, may indeed be considered some of the "hidden" caretakers of the faith.

When reviewing the Shi'ites, the Ismailis, the Sufis, and even the majority of mainstream Muslims like the Sunnis, as well as the many other branches and manifestations of Islam, it is noteworthy to remember the words of the Prophet Muhammed uttered upon returning from the lesser *jihād* (holy struggle of physical conflict with those opposing Islam) to the greater *jihād* (each individual's response to living within the religion of God). Muhammed said:

"O People, turn to God in repentance, and seek forgiveness of God. Indeed, I repent a hundred times a day."

Some Sufis believe that the act of asking anything of God results in being conscious of self, not of God. Duality of this sort is anathema in strictly monotheistic Islam and denies that whatever comes, good or bad, is ultimately God's will. To realize this subtle point, one must then repent of repentance and surrender to a (non)conceptualization of the ultimate Unity of Being, the *wahdat al-wujud* of Ibn 'Arabi.

*"Remembering repentance at the time of remembering God is forgetting the remembrance of God."*  
-Jafar as-Sadiq

*"Thus may I shatter this talisman "La,"\*  
And refrain forever from further repentance."*  
-Dr. Javad Nurbakhsh, present Master of the Nimatullahi Order of Sufis

\*(La" is the work "no" in the Muslim profession of faith: "There is no God but God", in which one negates the existence of all forms of divinity other than the Absolute with the word "la".)

In the eighteenth and nineteenth centuries, a number of shaykhs and darvishes of the Nimatullahi Sufi Order in Persia were executed for heresy. Several of the order's members at this time were also high ranking Ismailis, including the Ismaili Imam, the Aga Khan. mast Ali Shah a Master of the Ni'matullahi Order, reportedly once said of this relationship "I have a *murid* like the Aga Khan who himself has thousands of *murids* in most countries of the world." (9)

One of the martyred Nimatullahi's of this period was a brilliant musician named Mushtaq Ali Shah. The Ismailis and many others were attracted to Mushtaq and were drawn to the immense mystical power of his singing and *setar* playing. His negligence for outer convention was largely due to his mystical station as a *majdhoub*, one who is divinely intoxicated, or "mad-in-the-Divine." He was stoned to death along with a darvish disciple named Jafar (!) for allegedly singing and playing the call to prayer at the Jum'ah Masjid on the 27th Ramazan, 1792; apparently an action warranting capital punishment in the eyes of the orthodox Muslims. Deadly force on the part of the exoteric self-appointed guardians of the faith actualizes and perpetuates the need for esoteric hermeneutics.

Of Shah Nur al-Din Ni'matullah Wali (b. 1331 in Aleppo), the Sunni founder of the Nimatullahi Order of Sufis, it was said, "he knew the secret of al-Kimia". Not only did his followers believe in the art of al-Kimia, they most certainly continue to believe that their founder was adept in the sacred *art*, and that he was as well a sublime and unique Sufi master.

In the nineteenth century a disciple of Zuhur 'Ali Shah, a shaykh of Rida 'Ali Shah Deccani's in Persia; Ostad Gholam-Reza Shishegar is identified as being a practicing alchemist. Shaylch Shishegar mysteriously graces the cover of *SUFI: The Magazine of*

*Khaniqahi Nimatullahi* (Issue 3, Autumn 1989) which gives as the date of his death 1884 A.D., with no other explanation for the use of his picture on the cover of this particular issue of the magazine.

In Sufism, and Shi'ism, as well as in one of the later's extreme manifestations, Ismailism, and also in al-Kimis, the distinctions between inner and outer, interior and exterior, *batin* and *zahir*, after a certain point lose their dualism for the aspirant in the realm of absolute Unity. For the alchemist, the exterior symbols of the book of Nature correspond exactly to what is seen "inside", and the fruits of alchemical work are manifested by the transmutation of the *prima materia*, in every derivative sense.

*"And if all the trees in the earth were pens, and the sea, with seven more seas to help it, were ink, the words of Allah could not be exhausted."*  
-Qu'ran (31-27)

The revelations of the prophets are the congealed spiritual substances which form the living words of sacred texts. The text, then, like the teacher, is the transmuting agent, the *barzagh*, the barrier, or intermediary, which spiritualized the aspirant *body and soul*.

The adept cannot but wait in a state of pure silence or in what the Sufis call a state of annihilation (*fana*) in God. For the alchemist this amounts to the famous prayer before the *al-tannur*, or athanor (furnace). As the old saying goes: Silence is *golden*.

This is not to say that ordinary utterance *strictly speaking* is not derived from God; however, in order for the process to adhere to the recognition of a transmutation or a *spiritualization of the matter*, there must be a recognizable difference between revelation and other forms of expression.

*"Learning my meaning,"* said he (Poimandres), *"by looking at what you yourself have in you; for in you too, the word is son, and the mind is father of the word. They are not separate from one another; for life is the union of word and mind."*  
-Attributed to Hermes Trismegistus (10)

In Sufism, the Alchemy of the association of the aspirant with a darvish, the initiation into an Order, and ultimately the attention of the Sufi Master changes the lead of his imperfect nature into the gold of the perfected being who has found a unique union in God.

One of the primary transmuting tools used by the

Master is the inculcation of the *zīkr*, a Name of God that is invoked at every opportunity. Ibn 'Arabi states that the person mindful of the *zīkr* should regard it as an act of profound and personal worship. The invoker should not dwell on the meaning or even the understanding of the remembrance, but should rather commit the *zīkr* to practice automatically in order for it to cause a spiritual effect.

*"If the truths (realities) were manifest, the religious laws would be naught. As (for example), when copper becomes gold or was gold originally, it does not need the alchemy which is the Law, nor need it rub itself upon the philosopher's stone, which (operation) is the Path; (for), as has been said, it is unseemly to demand a guide after arrival at the goal, and blameworthy to disregard the guide before arrival at the goal. In short, the Law is like learning the theory of alchemy from a teacher or a book, and the Path is (like) making use of chemicals and rubbing the copper upon the philosopher's stone, and the Truth is (like) the transmutation of the copper into the gold. Those who know alchemy rejoice in their knowledge of it, saying "We know the theory of this science"; and those who practice it rejoice in their practice of it, saying, "We perform such works"; and those who have experienced the reality rejoice in the reality, saying, "We have become gold and are delivered from the theory and practice of alchemy: we are God's freedmen." (11)*

-Jalaluddin Rumi

Our modern world-view consistently seeks to separate and categorize in order to form opinions that engender debate and false notions of individuality and originality. Systems such as *jafr* evolve from the unified exegesis of ancient philosophical as well as practical Hermeticism generally and specifically from the human being's intuition of the wholeness of multiplicity. Potentially religion may become the meaningful vehicle it advertises that ultimately articulates the individual's search for origin through the perpetual freshness of revelation. The tension between arbitrary distinctions such as "outer" and "inner" work can only be resolved in a firm knowledge of oneness. Esoteric Islam remains a 1400 year-old "latter day" revelation which will alchemically produce this effect.

## NOTES

1. See: John Eberly, al-Kimia, The Mystical Essence of the Sacred Art of Alchemy (Manuscript in preparation, 1995), Chapter Two, "Jafar as-Sadiq", p.21.

2. See: John Eberly, al-Kimia, Chapter Three, "Jabir Ibn Hayyan", p.28.

3. Cleary, Thomas; The Wisdom of the Prophet (Boston, MA: Shambala Publications, Inc., 1994), page 93.

4. For more on Jabir's prophecy concerning the Glorious One, see: Henry Corbin, Cyclical Time and Ismaili Gnosis (London, England: Kegan Paul, 1983), p.126.

5. See: John Eberly, al-Kimia, Chapter Two, "Jafar as-Sadiq"; and Chapter Three "Jabir Ibn Hayyan" for more on *jafr* and its legacy, pp. 21-33.

6. *Ibid.*, pp 21-33

7. Reynold A Nicholson; The Mathnawi of Jalalu'ddin Rumi, 3 Vols. (Cambridge, England: E.J.W. Gibb Memorial Trust, 1926).

8. See: William C. Chittick and Peter Lamborn Wilson; Fakhruddin 'Iraqi-Divine Flashes (New York, NY: Paulist Press, 1982). This is an English rendering of 'Iraqi's *Lama'at*, an ecstatic, expressive, and poetic commentary on the doctrine of Ibn 'Arabi. The expression of the Sufi mystic's "religion" of Love can be traced to Jafar as-Sadiq, and, among others, most notably Ahmad Ghazzali, brother of Abu Hamid al-Ghazzali, and Master of the martyred mystic 'Ain al-Qudat al-Hamadhani.

See also: Ahmad Ghazzali Sawanih; Inspiration from the World of Pure Spirits trans. by Nasrollah Pourjavady (London, England: KPI Limited, 1986).

9. Meherally, Akbarally; A History of the Agakhanis Ismailis (Burnaby, B.C.: A.M. Trust, 1991), pp. 62-63.

10. Walter Scott; Hermetica (Boston MA: Shambala Publications Inc., 1985), Libellus I:6. p. 117.

11. Reynold A Nicholson, 1926 The Mathnawi, Introduction to Book V, p.3

[Biographical Note: John Eberly is an instructor of Art History at Hutchinson Community College.]



## CORRECTION:

In an unfortunate oversight, we forgot to include the name of **Brigitte Donvez** as the translator of several articles in Stone #11. The articles The Moon, The Oraculum, Cleaning the Amalgam..., and Creating the Seven Planetary Ens were all translated from the French by Brigitte.

# The Sign Of The Cross

by Mark Stavish, M.A. © 1994

(reprinted from New Moon Rising Vol. 7 #1)

Gestures and symbols have always played a major part in the Western Mystery Traditions. Yet, of all symbols, the cross has been the most prominent and influential in guiding western mystics towards Cosmic consciousness.

While seen as almost exclusively a Christian symbol, the cross has existed since the dawn of the mysteries. The Egyptian tau and ankh, the Cross of Christ's Passion, the Rosy Cross of the medieval and Renaissance alchemists, to the post-Vatican Two cross of the Resurrected Savior, all are historical variations of the same symbol that has lead a large part of humanity on its path to God.

## HISTORY OF THE CROSS

Generally, the cross is seen as the linking of an upright line with a horizontal line, or the active ( | ) with entity (-). While definite early sexual symbolism is present, it is on the psychological and spiritual levels that the cross is most fully explored. The Egyptian ankh, or looped cross, is said to be an example of this early sexual (i.e., creative) symbolism; however, most of its later uses are as a sign of life force and divine power in a complete sense.

Jung suggested that the cross has its origins in humanity's discovery of fire, and as such, is in reality a fire symbol derived from primitive human's rubbing two sticks together in order to start a fire for warmth, protection, and the creation of tools. It is interesting that words signifying cross, such as krosis, krouz, kreuz, crux, cruz, or croaz, have etymological similarities with words signifying fire. The roots ak, ur, or os, all signify cosmic light or fire.

The earliest crosses were simply marked at "T" or "X". Later variations added the additional arm to the top to form a "†" or "+". The equal armed cross (+) was used to represent the four cardinal Directions, Elements and colors of mankind (Hopi lore), as well as the Four Heavens of Zoroaster and its later variation in Jewish Qabbalah. When circled it became the four seasons, stages of life, and all the associations of life, death and rebirth.

Plato in Timaeus tells how the Demiurge reunited the broken parts of the fragmented 'World Soul' through two sutures shaped like (what we call) the Saint Andrew's Cross (X). The Egyptian ankh, or looped cross, has for many been the symbol of humanity's resurrection, in that it shows the initiate greeting the day with arms outstretched and head held high. One theosophical writer calls this posture

the "Madonna Posture" as if we are attempting to embrace all creation. She further states that it is also good for the thymus gland/heart area, in that it creates a feeling of openness and compassion right where the vertical and horizontal shafts meet.

During the Middle Ages the cross became chiefly associated with the crucifixion of Christ. As a result, the upright cross (†) became the symbol of Divine Power and Presence, the defeat of death and ignorance. By logic, the inverted cross, then became the symbol of blasphemy, demonic power, or the rejection of Christ sacrifice. Yet this was a strictly historical interpretation of that time, for Saint Peter requested crucifixion in this manner, inverted, as he felt he was not good enough to hang the same way as did Jesus. Earlier, and later, mystical doctrines use the various forms of the cross to signify different flows of Cosmic forces, potential and rhythm.

In England the cross was associated with the Yew tree, often seen growing in churchyards. Christ in medieval songs and stories is said to have been "hung on a tree" just like the Norse god Odin. Christian mystics would later change this to the "Tree of Life" of medieval Jewish mysticism, or Qabbalah.

## USE OF THE CROSS

By using the sign of the cross in a conscious manner, we can create within ourselves a condition that is supportive of mystical experiences and expanded awareness. We in fact make ourselves open and willing channels for Cosmic Wisdom, Universal Love and Creative power to manifest in our lives and the world. The Christian mystics called this the axis mundi or World Axis -the joining of Heaven and Earth.

In his work The Nature and Use of Ritual, Roche de Coppens quotes a Masonic-Rosicrucian document in which 'Bishop Theodotus' states:

"When we say "In the Name of the Father" and place our fingers on the forehead, we actually point to an important organ in our spiritual body just below the space where God dwells in us "on high." The vibrations set up in motion by our loving thought about our heavenly Father activates the Divine Essence of the "Crown" which pours into our Heart center as a veritable though unseen Glory [Shaft of White Light]. This activation of the "Crown" itself is described by St. Peter: "Ye shall receive a Crown of Glory." When we say "And of

the Son" and place our fingers on our heart, we again actually point to a space in our spiritual body where the Divine Light, in the words of the Prophet Isaiah poured upon us from "on high," is activating another spiritual organ suffusing us with the Divine Love of the Son. And when we say: "And of the Holy Spirit," touching our right and left breast respectively, we activate these spiritual sensoria within us which manifest as the creative and vitalizing power of the Holy Spirit in our lives. Finally, when we say: "Amen" and join our hands together, mentally affirming the presence of the Triune God within us, we actually close the spiritual currents within the periphery of our spiritual body in order to maintain this awakening to spiritual awareness as long as possible"

- S.R.I.A. Documents

By bearing the cross of incarnation, like the Cosmic Christ before us, we can know the light of our Inner spiritual cross of Illumination, Resurrection and Salvation. Just as Constantine went "by way of the cross" so can we know the esoteric meaning of via crucis in our daily lives. By acknowledging, accepting, invoking, and applying Cosmic Wisdom and Universal Love, and connecting the two through the power of the Holy Creative Spirit, we can personally know the Christ Within. When this happens, we partake of the true spiritual communion, or Holy Mass, in which all are joined in the Corpus Mystica Christi or Mystical Body of Christ. It is here, that all true and sincere believers are united in the Invisible Church of which Eckharthausen spoke:

"It is necessary, my dear brothers in the Lord [Cosmic Consciousness], to give you a clear idea of the interior Church; that of the illuminated Community of God which is scattered throughout the world, but which governs by one truth and [is] united in one spirit.

"...It is the most hidden of communities yet possesses members from many circles; of such is this School. From all time there has been an exterior school based on an interior one, of which it is but the outer expression. From all time, therefore, there has been a hidden assembly, a society of the Elect...called the interior Sanctuary or Church.

"...But when men multiplied, the frailty of man and his weakness necessitated an exterior society which veiled the interior one, and concealed the spirit and truth in the letter...wrapped in external and perceptible ceremonies...which the symbol of the interior, might be degrees by enabled safely to approach the interior spiritual truths...so that the sensuous man could...be gradually...led to interior truth..."

- Cloud Upon the Sanctuary, Letter Two, von Eckharthausen

## MODERN MYSTICAL USES OF THE CROSS

Since the 'Occult Revival Period' of the 19th and early 20th centuries, several variations of the Sign of the Cross as a mystical and magical gesture have become public. While many of the organizations that lay claim to these techniques also make claims of somewhat questionable historical antiquity, the effectiveness of the method is what must be judged, and not history that may be more mythology than fact.

One of the largest, most splintered and yet surprisingly effective of these movements is Martinism. Tracing its lineage to the French "Unknown Philosopher" Louis Claude de St. Martin, and his rogue teacher and master, Martinez Pasquales, Martinism came into full bloom in Europe, America and other areas around the world before World War One.

Under the careful formation and leadership of Dr. Gerarde "Papus" Eucasse, Martinism quickly grew into one of the largest and most widespread mystical movements in the world. Unfortunately, such quick and sudden growth also led to a fractioning of the original Martinist Order into several schismatic organizations and independent lodges. Despite their political quarrels and doctrinal differences, they all remained true to their rituals, teaching methods and core beliefs.

Since Martinism identifies and defines itself as "esoteric Christian knighthood" based on initiation and the Qabalah, it is no surprise that several variations of the cross appear in some of its rituals.

In The Martinis Tradition (vol. 1) Rene Cossey gives a Martinist ritual. The preface to the ritual outlines some of the long-standing history of the cross in both Christian and pre-Christian periods.

Quoting Jean Danielou's Les Symboles Chretiens Primitifs (Paris, 1961). Cossey points out that the tau was used as a "Sign of the Elect" in the Old Testament, being traced on the heads of the initiates by the Angel of Yahweh. The ancient Egyptians, Gnostics, Eleusian Mysteries and Rites of Dionysos, all had uses for the tau before it was recorded in Revelations, or adopted as the Passion Sign of Christ.

The High Priest of Israel had it traced upon his head with Oil of Unction upon his consecration. Early Christians in North Africa had it painted or tattooed on their heads as a sign of faith. Medieval rabbis visualized it as they were tossed into the flames during the Inquisition as a shortened version of the Tetragrammaton.

For the purpose of this ritual however, the 'operator'

is advised to trace it upon their forehead with their right thumb (while possibly visualizing it in the aforesaid Qabbalistic fashion), after making a plea for Divine Intercession in the world's state of affairs. At one point however, the ritual changes to tracing the cross with the thumb, as well as the forefinger and middle finger. This possibly symbolizes the coming together of various Cosmic forces.

An alternative method of tracing it is to use a candle in the air in front of oneself. By drawing it as such "4" it symbolizes resurrection. When drawn "†" it symbolizes Divine incarnation or assistance.

## THE GOLDEN DAWN

While the teaching of Martinism have had a wide influence on many mystical organizations (particularly those either claiming the Martinist banner, or of a Rosicrucian variety) the Hermetic Order of the Golden Dawn has by far had the widest and most well publicized impact on Western occult thought in the last 100 years.

Formed in the last quarter of the 19th century, the Golden Dawn was a direct offshoot of a quasi-Masonic organization calling itself the Society Rosicrucia in Anglia (S.R.I.A.). Formed by a group of Masonic scholars seeking the Rosicrucian roots of the Masonic Order, the S.R.I.A. later became the nucleus for the Golden Dawn. Through the Golden Dawn the S.R.I.A. sought to establish an outer organization where members could be trained in spiritual rites, whereby they might be prepared for later admittance into the Order of the Ruby Rose and Golden Cross or their version of the Rosicrucian Order. Like Martinism, which came only a few years later, the Golden Dawn sought to reestablish the lost entry way into the secret and highly sought Rosicrucian Order.

The Golden Dawn's greatest contribution to the understanding of the Sign of the Cross comes in its highly revered ritual meditation known as the "Qabbalistic Cross." In this ritual, like that described by Bishop Theodotus, the initiate visualizes brilliant spheres of light and the formation of a cross of white or golden light within themselves as they recite the invocation: "For thine (head), is the Kingdom (heart), and the Power (right shoulder), and the Glory (left shoulder), unto the ages, Amen (hands together in prayer)." This simple but powerful act, when done with concentration and sincerity, can bring us into contact with Cosmic Wisdom, Love and Creative Power, just as its Christian variation can.

## CONCLUSION

While this is just a brief and (hopefully) practical

introduction to the meaning and uses of the cross by mystics across the ages, it is important to remember, as Eckharthausen has pointed out to us, we are not alone on our spiritual journey. We are supported by a host of "Unknown Superiors" or invisible allies that constantly seek to uphold us on our Pilgrim's Progress. By seeking a deeper understanding of our spiritual symbols, and using them in our daily meditations and prayers, we can strengthen ourselves inwardly and bring ourselves one step closer to God's promised Kingdom - "Via Crucis!"



## News & Notes

*continued from page 1*

the historical successes in creating the Stone of the Wise were done by husband and wife teams. It was nice to see so many women talking about their lab projects. I'd like to see someone write an article on this topic.

Jean revealed a little about the new course he is working on that emphasizes a simpler approach to alchemy and qabalistic work, a method of training and practice that will not require the investment in lab equipment nor the addition of a dedicated room for your qabalistic rituals. A course that I hope will have a broad appeal, practical value and tangible results. There is no release date yet but we will keep you posted and notify the membership when it is available.

## ORA News:

I have regretfully been delayed in getting our new research group up and running, primarily because I've been traveling a lot more than I anticipated over the last few months. Things are settled now and for those of you that have made inquiries, thank you for your patience and you will be hearing from me by early January. If you are curious about the ORA project read page 16.

## Strange Brew:

If you've been keeping up with the gossip then you have probably heard rumors that PON or PON members are doing alchemical experiments with nuclear material. **This is, of course, absolutely false.** However, when I got to the Chicago seminar the first question a person asked me was about information on doing alchemy with nuclear material! (He was not a member.) I instantly thought back to an article I read years ago by Adam McLean that I think addresses this topic expertly and with his permission I have reprinted it here; please read it.

Enjoy the issue, as always I welcome your comments and your submissions; the article deadline for the next issue is Feb. 20th 1996.



# The Spiritual Implications of Nuclear Power

by Adam McLean

During the 1960's, Louis Pauwels' and Jacques Bergier's book, *The Dawn of Magic* (later published as *The Morning of the Magicians*) achieved a great degree of popular success, and indeed was the forerunner and set the style, for a great many such sensationalist books relying on and perpetuating the misunderstandings, the public in general have of Occultism. Despite the books many failings, its sensational journalistic style, its many inaccuracies and indeed distortions of the facts of occultism, it has created a myth that there is some kind of connection between Nuclear Power and Alchemy.

It would seem at first glance (all that is necessary for sensationalist writers) that since both the work of the Alchemists in transmutation, and that of present day nuclear physicists transmuting elements by means of radioactive energies, have one facet in common, they are the same. However those who have studied deeply the writings of the Alchemists find there only the deepest respect, and reverence for Nature. Many times the Alchemists repeat the exhortation *Our way is the way of Nature* All men who work beyond Nature are deceivers and work in an unlawful manner.

Therefore can the world view of the Alchemist be reconciled with the aims of the Nuclear Power industry? Does a present day Alchemist immerse himself wholeheartedly in the development of Nuclear technology? I think not. These two realms that of the Alchemist and that of the advocate of Nuclear Technology are quite separate, and indeed arise out of two very distinct world views. The Alchemist wishing to experience the forces inherent in Nature to their fullest fruition - a spiritual picture of the world: the Nuclear Technologist working to design and create environments on the Earth, where the life of Nature cannot exist -out of purely materialistic considerations and motives.

The following is based on the content of a lecture I gave recently (late 1978) in Edinburgh, as it seemed to me that it has become necessary that the consequences for humanity and the future of the Earth planet, of the development of Nuclear Power, should be made more public.

The question of the development of nuclear power is one of the most significant lying before present day humanity. The arguments for and against this de-

velopment don't seem able to be answered on purely material grounds, and perhaps if we turn to the spiritual aspects we might be given a definite answer. Indeed, I want to show that the spiritual implications are quite definite, quite unequivocal over this matter of nuclear power

But first let us look at the various aspects from which this question can be viewed:

**Material Implications** - here we have the arguments over the matters of the hazards of pollution, the yet unsolved radioactive waste disposal problem (waste that will be highly radioactive for tens of thousands of years), the dangers inherent in high technology and the fact that much of this is yet untried and experimental, and with great complexity of equipment the possibility of failures or of human error becomes inevitable. The smooth talking advocates of nuclear power invoking the marvels of modern science have at present avoided answering many of these points.

**Social Implications** - the social structure in which we live, is the environment of the soul, and determines the inherent possibilities of developing the full potentialities of the soul. The kind of social structure needed to police and control dangerous nuclear materials, the hierarchy of a small number of technicians with little vision and enormous power at their disposal, will lead to a society in which basic human freedoms are removed. Already this is beginning to emerge, as politically active groups in the antinuclear sphere are under close scrutiny by the security forces, and the only police force in this country to be permanently armed, is that which guards nuclear installations. There are far reaching social and moral implications arising out of nuclear technology.

**Spiritual Implications** - I believe provide a definite answer to this vital question, which spiritually involves the future of humanity, the direction of evolution, not only for this planet, but also for the potential spiritual development of the mineral kingdom.

To get to the spiritual root of this question we shall have to consider the nature of the material realm, at the nature of substance. 'Substance' is that which 'stands under', is but the material manifestation of archetypal spiritual being. Substance is but the body



of spiritual being, and we know through various occult traditions that this material envelope only came in to existence with the Earth, but that before this lay long aeons of spiritual evolution. The descent of the spiritual archetype, spiritual essence into substance, occurring through previous periods of evolution, into what we find today as the chemical elements on the Earth. (By 'elements' here I refer to the elementary chemical substances, rather than the alchemical elements fire, air, water, earth.) These chemical elements have woven into them the history of previous incarnations of the Earth planet in Cosmic evolution. This can be seen from the writings of the Alchemists, and the whole process is described in much detail by Madame Blavatsky (a great hermeticist) in her 'Secret Doctrine.' Rudolf Steiner, another great occultist describes this large scale cosmic evolutionary process in his book 'Occult Science', in which he talks of the Ancient Saturn stage, the Ancient Sun and Ancient Moon periods which preceded the Earth, and were previous evolutionary embodiments of this planet. Kabbalists will also be familiar with this picture, and would say that there is enfolded into the chemical elements on the Assiatic plane, the potentialities of the Atziluthic, Briatic, and Yetziratic levels of existence.

Let us look at these chemical elements from this perspective.

Hydrogen is the first element, the simplest chemically, and contains within itself all the potentialities of the other elements, being composed so the chemists tell us, of the basic building blocks of matter, the *proton* and the *electron*, bound together in a polarized form as Hydrogen, or when united together becoming the neutron, and combinations of these three units determine the series of chemical elements. Thus Hydrogen is indeed a cosmic substance as hidden within it spiritually are all the other elements, and it is found all around the physical Universe as the most abundant element.

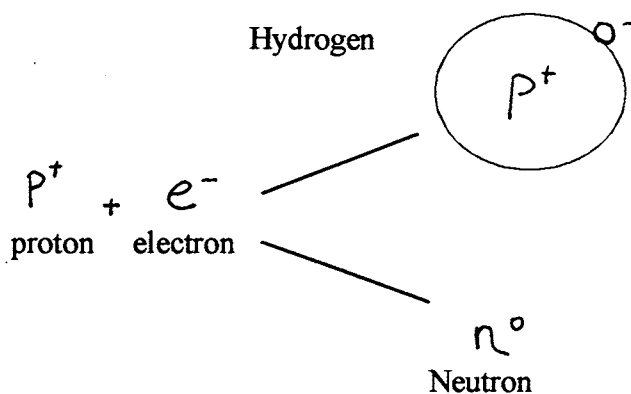

Hydrogen is truly the first descent of the spirit into substance. Let us follow up the series of chemical elements which can be formed into a regular pattern called the periodic table, if we set them out in a descending series according to their atomic numbers, that is the number of protons in their atoms. We shall just look at a few of the more important of these elementary substances that are the fabric of the Earth. To start with *Hydrogen* and *Helium*, both gases, then quite quickly we come to elements 6,7,8, *Carbon*, *Nitrogen* and *Oxygen* the building blocks of all organic substances, which are the embodiment of the etheric forces, that anchor the etheric forces into physical materiality. Then to *Sodium* a soft white metal, which ignites when placed in water, yet is the alkali base metal of common salt, without which we could not live, indeed Sodium has a particular task in the nervous system. *Silicon*, the substance which as quartz forms the rocks of the earth's crust. *Phosphorus*, *Sulfur* essential to life in the formation of proteins substances which can act as carriers for the life forces. *Calcium* involved in the formation of bones. And so down deeper into materiality. The first true metals *Vanadium*, *Chromium* needed as traces elements in the growth of plants. Then *Iron*, now deep into materiality we meet in Iron an element which is still so necessary to life. Iron which is the anchoring atom at the center of the hemoglobin molecule, which in our blood acts as the carrier of the life giving Oxygen. From Iron we descend even deeper into materiality, *Copper*, *Arsenic*, *Silver*, *Tin*, *Gold*, *Mercury*, .... One might mistakenly think that this process of adding extra protons and neutrons could continue indefinitely. However this is not what happens.

The process does come to an end. With the element number 82 - *Lead*, we reach a turning point (with an exception in the one stable isotope of Bismuth 83), all heavier elements are unstable, that is they decay radio-actively, with the emission of various rays, and disintegrating, change their atomic nature, in a sense seeking a stable elementary form. For example the element Thorium, decays radio-actively through a chain of different unstable elements to form the stable Lead, and the same is true for Uranium.

We thus see that these heavier elements are materially too dense to bear the spiritual archetype. They are wholly given up to material forces and consequently have no eternity, no permanence, but decay over a period of years to stable elements such as Lead. (In fact, chemically this point is reached when the number of nucleons (protons and neutrons) exceeds 209).



THE PERIODIC TABLE OF THE ELEMENTS

1 H Hydrogen																	2 He Helium
3 Li Lithium	4 Be Beryllium											5 B Boron	6 C Carbon	7 N Nitrogen	8 O Oxygen	9 F Fluorine	10 Ne Neon
11 Na Sodium	12 Mg Magnesium											13 Al Aluminium	14 Si Silicon	15 P Phosphorus	16 S Sulphur	17 Cl Chlorine	18 Ar Argon
19 K Potassium	20 Ca Calcium	21 Sc Scandium	22 Ti Titanium	23 V Vanadium	24 Cr Chromium	25 Mn Manganese	26 Fe Iron	27 Co Cobalt	28 Ni Nickel	29 Cu Copper	30 Zn Zinc	31 Ga Gallium	32 Ge Germanium	33 As Arsenic	34 Se Selenium	35 Br Bromine	36 Kr Krypton
37 Rb Rubidium	38 Sr Strontium	39 Y Yttrium	40 Zr Zirconium	41 Nb Niobium	42 Mo Molybdenum	43 Tc Technetium	44 Ru Ruthenium	45 Rh Rhodium	46 Pd Palladium	47 Ag Silver	48 Cd Cadmium	49 In Indium	50 Sn Tin	51 Sb Antimony	52 Te Tellurium	53 I Iodine	54 Xe Xenon
55 Cs Caesium	56 Ba Barium	57 - 71 Lanthanides	72 Hf Hafnium	73 Ta Tantalum	74 W Tungsten	75 Re Rhenium	76 Os Osmium	77 Ir Iridium	78 Pt Platinum	79 Au Gold	80 Hg Mercury	81 Tl Thallium	82 Pb Lead	83 Bi Bismuth	84 Po Polonium	85 At Astatine	86 Rn Radon
87 Fr Francium	88 Ra Radium	89 Ac Actinium	90 Th Thorium	91 Pa Protactinium	92 U Uranium	From this point on all elements are radioactive											

The Trans-Uranium Elements  
 All of these elements do not exist naturally on the Earth. They have been brought into being through nuclear fission.

93 Np Neptunium	94 Pu Plutonium	95 Am Americium	96 Cm Curium	97 Bk Berkelium	98 Cf Californium	99 Es Einsteinium	100 Fm Fermium	101 Md Mendelevium	102 No Nobelium
--------------------	--------------------	--------------------	-----------------	--------------------	----------------------	----------------------	-------------------	-----------------------	--------------------

Thus many of these radioactive elements are found in very small quantities in nature. For example Radium, was isolated by the Curies as a few grains, gained from laborious processing of many tons of first grade pitchblende, a naturally occurring ore. Similarly Uranium, of the heavy elements found in the largest quantities, is extracted from ores with very low concentrations of the metal, indeed in concentrations which would never be considered viable for any other metal. Uranium is found, for example, in very small quantities, almost homeopathically distributed in granite. And thus we can see that nature has sought to dilute rather than to concentrate these radioactive substances. Indeed, if nature had not done so, then life on this planet would have been threatened, for as we all know these radioactive radiations attack organisms in such a way as to loosen the connection between the etheric and the physical bodies. In the plant this gives rise to mutation, in the animal to cancer

The process of nuclear power involves concentrating and purifying substances such as Uranium, which is very difficult, much more so than purifying Iron, Copper or Tin. But when one flies in the face of nature and purifies Uranium, a very significant thing happens, which is the basis of the nuclear fission process. Uranium spiritually cannot stand on its own being, and when brought into a solid mass, its decay is accelerated, and indeed once over a certain critical mass, a self sustaining chain reaction is set up and a type of radioactive decay takes place in a millionth of a second. Thus the atomic bomb.

Put quite simply, for there is no atomic secret, take two highly purified pieces of Uranium whose total mass exceeds about 35 lbs, and bring them together quickly, and you will have an atomic explosion. As simple as that - a mere 35 lbs or so. Take a few tons of Uranium in small pieces, and put it together with other materials to separate the pieces and you have a nuclear reactor - a 'controlled bomb'.

Spiritually, what takes place in nuclear reactions, is that working with substances which are wholly given up to material forces, one is bringing to the life of the Earth, forces and substances that do not arise naturally out of spiritual potentialities, which as we have seen are enfolded through evolution into the stable chemical elements. One must begin to work to release the spiritual in matter, rather than incarnating substances without a spiritual aspect.

Inside the Atomic Pile, the nuclear reactor, isolated from the Cosmos, a highly unnatural process takes place, a process which nature has sought to avoid, *Uranium*, exposed to the intense radiations in that environment is transmuted into elements even more given up to the material forces, completely unconnected with any spiritual dimension - *Neptunium*, the dreadful *Plutonium*, aptly named element both extremely poisonous and radioactive, now sought after for use in Nuclear weapons, *Americium*, *Berkelium*, *Californium*, a horrific element which is probably the basis of the so called Neutron Bomb. None of these elements are found on the Earth as a result of spiritual involution into matter of the

spiritual archetype. These terrible elements are created only in the atomic pile.

This undoubtedly the most significant aspect of nuclear technology - the incarnating of substances with no spiritual content, substances inimical to life, exposure to which destroys the connection between the etheric and physical bodies of all living things, resulting in mutation and cancer. And some of these substances which man has incarnated, like Plutonium will be around for tens of thousands of years.

What is mankind doing? Are we aware of the spiritual consequences of this act? I seriously doubt that people are conscious of the implications of this development. of nuclear power, indeed the history of this development seems to be a purposely muddled, secretive and confused one. For example, the real reason for the early development of the nuclear reactors was not to generate power for so called peaceful purposes, but rather to create Plutonium for atomic weapons, in particular the hydrogen bomb. The whole history of nuclear science is tied up with war and destruction, one sees incredibly negative forces working towards its development. Great technical difficulties have been encountered in nuclear installations which have been glossed over, and various accidents have been hushed up. The true cost of producing nuclear power generated electricity has been hidden by secret subsidies, e.g. the whole cost of research work is not accounted in the final cost analysis of nuclear power generation. Nor has the problem of nuclear waste been solved.

Yet all the advocates paint a rosy picture. I think that here we can see working various forces opposed to the spiritual evolution of humanity, who seek, through immersing man in nuclear science, to bring this evolution to a halt. These forces, we might call them 'Ahrimanic' beings, seek to bind man to materiality, to isolate him from the ongoing unfolding of the spirit in matter. The descent of the spirit into matter has now reached a turning point on the Earth, and from now on it is man's task to recognize and release the spirit in matter, to reveal its full potentialities. The descent of the spirit into matter reached a turning point at the element Lead (this was known well by the ancient alchemists). To work with the heavier radioactive elements devoid of the spirit, is to chain man to the Earthly realm, and indeed will result in the laying of the foundations of what has been known in occultism, as the eighth sphere. This is potential in evolution. It is man's choice and task as to whether he follows this process of establishing the eighth sphere, which will result

from descending deeper into materiality, than the Earth forces, and the creation of a materially powered world, cut off from the course of spiritual evolution, the shadow of the Earth - the eighth sphere.

The forces opposed to man's spiritual evolution, have in the midst of twentieth century materialism, found a way of working directly in the material realm, by means of bringing to the Earth, substances which do not belong in this sphere, and which loosen the connection between the physical and etheric bodies. Behind the development of nuclear power, there lies a spiritual battle for the future development of mankind.

The 'black alchemy' of nuclear technology, works to despiritualise matter, to cut matter off from the spiritual world.

The future evolution of mankind lies in an alchemical tradition which works towards the spiritualising of substance, and the development of man's spiritual relationship to matter.

(Author's note: This article was written in 1979, and published in Hermetic Journal Number No. 3. If I was writing it today I would add some additional material and try to penetrate more deeply into the nature of radioactive decay from an alchemical perspective. Regrettably I do not have time at present to revise the above article or write further on this topic. - Adam McLean)

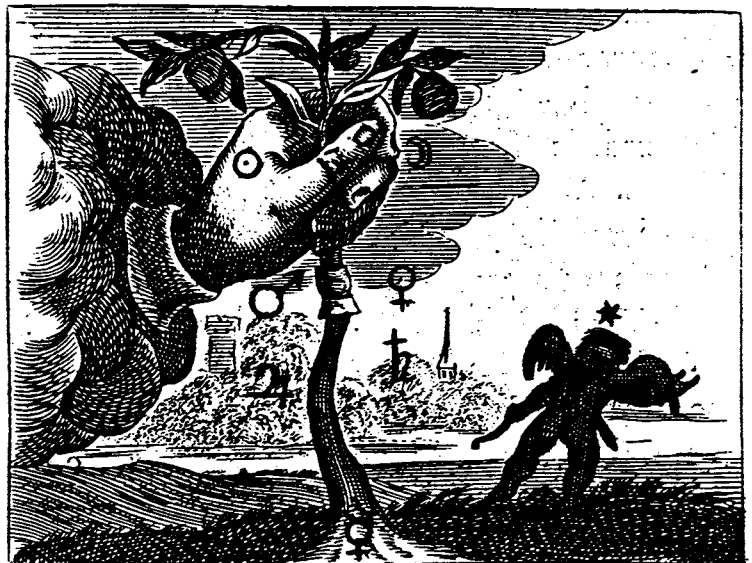

# The Tarot: Structure & Use, Part 1

by Ned Darenuith

In order to use the Tarot correctly you must understand it. You must not only be able to know the meanings of the cards and the various spreads but also what divination itself is. The following ideas should help you to understand what the tarot can do for you and what it can't and thus help you to make the most of it.

First of all the Tarot is a system of symbols. Not merely a disordered aggregation of symbols but an orderly system of symbols. In any orderly system form creates meaning and thus the more formal information which we have about the nature of a reading the more information we have on which to build our meaning. Let me give you an example. I used to be bothered by a strange woman who would call me up and say "The Devil showed up in my cards today, what does it mean?" All I could ever tell her was that it beats me, because she could never tell me what cards were around it or where it showed up in her card spreads. This is like calling me up and saying to me "someone said 'gross' to me today, what does it mean?" How am I supposed to know? What was the context in which it occurred? If they didn't know that then all I could do was run through a catalogue of what it might have meant. I could say that it might have been a gross of pens, a dozen dozen quantity of writing implements. Someone may have been speaking German and been referring to something great. Someone may have been using American slang to refer to something rather disgusting. Perhaps someone was referring to an old acquaintance of mine, Barbara Gross, who was anything but disgusting. The point is that unless I know the context in which a word is used I know little of anything but its potential meaning. The same is true of a Tarot card, until I know where it showed up and what the overall context of it is then I don't know enough to give meaningful information.

There is another thing that we must consider. In a lot of Tarot literature the tendency is to think in terms of the cards being some type of means for the psychic abilities of the practitioner to tune into the situation with. According to this view the fall of the cards can be meaningless but somehow the reading will let the mind of the diviner tune into the matter and give a correct interpretation. If this were the case why bother with the cards at all? Indeed, if the cards were not capable to at least point in the di-

rection of the events then they could by suggestion cause more problems than they would be worth as a tuning in ritual. This whole problem arises because of the closet materialism which so afflicts most people in our society and which colors the thinking of people in the occult field without their realizing it. These people are unwitting Cartesians who believe that "mind" (in its wider meaning as self-conscious awareness, not merely intellect) and "body" are separate substances and ne'er the twain shall meet. Since Mind (and here we mean the widest meaning—cosmic mind the disembodied mentation of Plotinus) is immaterial and matter is solid, hard and immovable and impervious to our wishes the people who think this way want to let them selves off as easily as possible by thinking that the divination is only a ritual preparation for their Psychic flights. I should think that for the reasons stated above, that better ones should be available.

My own experience is this: if you expect the cards to give you an intelligible account of a matter, and read them with that in mind and never give them any slack to slip by. Then they will give you an exact and cogent reading which will require no psychic skills to interpret. Now this is not to say that such psychic skills are not useful in such a reading situation, only that they are not necessary when you have established a proper relation with your cards. You should not have to read their mind, they should come right out and tell you exactly what they mean. If they can't do that then you can do other things instead. However, don't give up on them quickly, they are valuable in themselves. It may take a little time to establish the proper relation with them. We shall deal with that later. Also please see the appendix on Psychicism and Intuitionism for more discussion on these points.

Well with that out of the way how can we think of the tarot? The first way is as a translator. Imagine that the tarot is a translator that a message is coming to you as a foreign language which you cannot understand and you turn to the tarot as a language which can be understood by both you and the person sending the message. Like all translations something may suffer in the process, but that is the price you pay even for understanding what can be translated. Let me give you an example. French does not have a word for shallow, instead it says not very deep (*peu profond*). If you came across French

statements relating to a not very deep stream it might take you a moment to reword it as "shallow" if you were not familiar with French idiom. The Tarot itself may have some difficulty in describing something and more then once I have been faced with quite literally a game of twenty questions.

Another way to think about the Tarot is like a game of Scrabble in which the letters can be used up and make certain words impossible to spell. Thus in a reading you may find yourself in an ambiguous situation because of a situation arising in which all the I's have been used up. You want to spell Ecliptic, but find your self unable to do so because there are no more Is! A similar situation can arise in a tarot reading. Two situations within the provenance of the spread could be well represented by "Temperance" but it can of course only be used once. This question is closely related the use of information theory in the theory of divination we will put off more discussion until the appendix which deals exclusively with that subject.

The final way in which we can look at a Tarot reading is as a game of charades. In many cases we are looking at a situation in which simple direct communication is impossible and in which we are forced to use the metaphorical speech which characterizes a game of charades. It might not be a bad idea to think in terms of the tarot saying to us "First word; sounds like-- Temperance" we must then reconstruct the intended meaning as best as we can.

### The Structure of the Tarot

Before we can really enter into a discussion of the structure of the Tarot, we must answer the question which Tarot and why? Generally speaking each Tarot deck design is a member of one of several large families. It is important to realize that what I have said up to now is applicable to all types of Tarot decks and to a lesser extent to all forms of divination. However what I am going to say now about the structure of tarot decks is applicable only to those of a certain family, those derived from the teachings of the Order of the Golden. Interestingly this will include almost any deck which the student cares to pick up. The families to which the following analysis will not apply are mostly French and Italian "Esoteric" decks in which a great deal of astrological symbolism are given on the cards.

First let us deal with the decks which we do recommend. Almost any deck which is derived from the Rider-Waite deck will do. Some of these have

overall symbolic schemes which are dubious because of their references to other cultures. There are for example decks of a rider-Waite derivation which are "Japanese"(very pretty), "American Indian" (rather ugly) and "Mayan" (interesting). I have never worked with any of these and they may work very well especially if they have some kind of appeal to you, but I am suspicious that the extraneous cultural baggage may make them less accurate then one which is more "Western" in its costumery. I could of course be being overly cautious in this matter. I have a special fondness for the deck called the Morgan-Greer because of its fine art work and vivid coloring.

Of other decks which come from the Golden Dawn the Bota Deck is good and because it does not have the pictures on the numbered cards is useful in those readings where because of the nature of the reading the pictures which Waite created for the numbered cards in his deck are misleading.(See note following article in Part 2 clarifying the relation of Waite to GD.)

I don't like the Crowley deck. While artistically it is very interesting, it is shot through with Crowley's dubious metaphysics (if we can even elevate it to that height!) and I wonder if something that corrupt can give a good answer.

There are some very nice looking French and Italian "Esoteric" decks, unfortunately they have all been influenced by Eliphas Levi and usually bear the Hebrew letters and planetary attributions in fashions which are different from those which come out of the Golden Dawn "Tradition" (well it has been a hundred years now, maybe we don't need the quotation marks!). I am afraid that the symbolism on the card itself might adversely affect the reading which is why I don't recommend them, but if one of these really catches your eye you might try it and see if you can talk it into working for you correctly.

Well, now that we know which Tarots are recommended we can ask ourselves what we can do with them. In our discussion we will talk about three "models" of the Tarot. By a model we mean an intellectual structure which provides guidelines for our interpreting the cards in any particular spread. If you haven't noticed already there are lots of meanings for each card and it is not always easy to tell which one to use in a given reading. Using the models given in Part 2 and specifying the type of information for which we are looking can go a long way to clarifying which meanings should be used to answer a particular question.



*Only a few copies left!*

Attention Students of Qabala and the Western Mysteries...

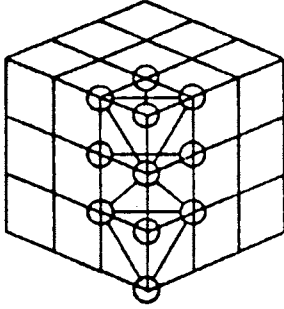

*"In the study of Qabalah there is no more important glyph than the Cube of Space..."*

Paul Foster Case

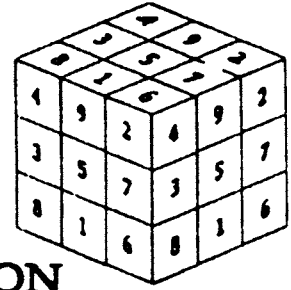

## THE CUBE OF SPACE: THE CONTAINER OF CREATION

a book by Kevin Townley

Topics include:

- \* Generation of the Cube of Space through geometry.
- \* The Magic Square of Saturn.
- \* Relationship of the Cube to the Tree of Life.
- \* Placement of the Tarot (Minor Arcana) on the points of the Cube.
- \* The Cube's relationship to the Macro and Microcosm.
- \* The Cube of Space in the Four Worlds.

To order send \$45.00 plus \$3.00 for postage to  
Archive Press, Box 11218, Boulder, Colorado 80301.

*"As Above, So Below"*

*When you understand the process of Divine Creation on the macrocosmic level, you can apply those same principles on a personal (microcosmic) level!*

## The Philosophers of Nature unveil...



# *The O.R.A. Project*

OCCULT RESEARCH & APPLICATION

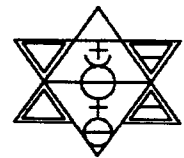

P.O.N. has for the last few years maintained a research group to work on various laboratory alchemy projects. Now we wish to form a group of those members who are interested in participating in research projects involving magic, kabbalah, and various other occult subjects.

If this interests you, please send a self-addressed stamped envelope to: Ken Miller, 405 West Washington Street #314, San Diego, CA 92103; or e-mail Ken at StonePON@aol.com (You will receive a questionnaire that will allow us to assess your interests and talents. Any suggestions for research projects will be cheerfully considered.)

WANTED: The ORA project is looking for an English or Hebrew copy of The Book of the Angel Raziel (Sepher Raziel; also titled Raziel ha-Malach). An English translation is known in the British Museum: Sloane No. 3826. If you have a copy or translation please contact the ORA project. Thank you.

*He's back!*  
 (THE LAST GREAT ALCHEMIST IN PRINT)

# ALCHEMICAL WORKS: Eirenæus Philalethes Compiled

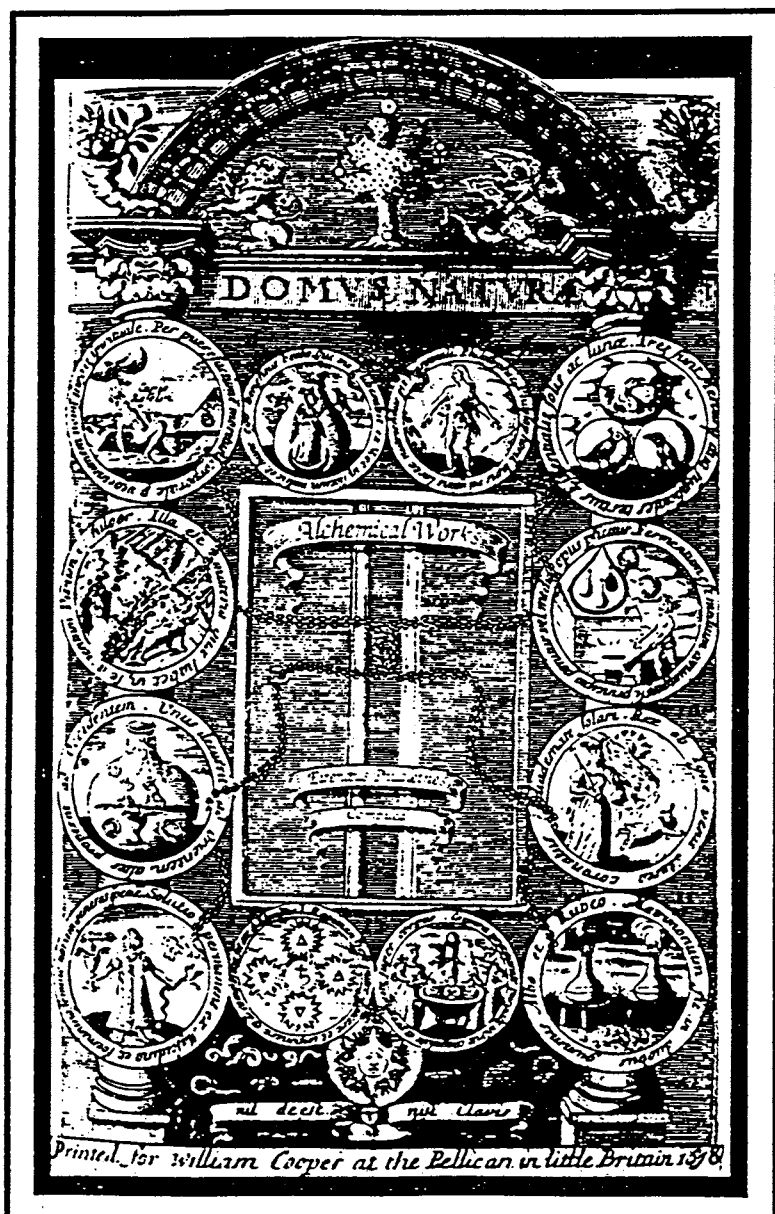

Eirenæus Philalethes, mysterious alchemical adept of the seventeenth century has elicited intrigue, study, and controversy for historians, littérateurs, and scientists since these works were published beginning in the mid-1600's.

This volume is unique. It is the only to contain all Philalethes' works currently available in English, and it is indexed.

Original format has been carefully preserved throughout, offering readers access to complete, authentic, and legible text and content for their enjoyment and studies, without having to resort to the microfilm copies previously available to most readers as the only source for much of the text contained within.

The practice of alchemy has been perennial for all of written history, woven through one civilization and into the next, often tying them together. It is a science, a philosophy, a mystery, and a quest. The very word connotes a magic transcending our limited beliefs about the laws of nature. It was used as a tool of charlatans, who did much through their deceit to destroy the reputation of the science. Much more often it has been a field of study for great minds. C. J. Jung spent his last twenty years illustrating its value in framing the workings of the subconscious through alchemy's rich use of metaphor. Sir Isaac Newton poured over Philalethes' tracts, finally preparing what he thought to be *Philosophic Mercury* in 1675.

The essence of alchemical writings has been consistent through the centuries, while the details have been inscrutably and defiantly deceptive. Philalethes is called the last great alchemist in print. This collection presents a treasure map for many uses.

hard cover 592 pages indexed a.f.p. ISBN 0-9640067-0-7 \$60.00

\$65.00 U.S. Postage paid to:  
**LPN-USA**  
 Box 11218  
 Boulder, CO. 80301

# ORA ET LABORA

Vol. 2 No. 3

Copyright 1995, The Philosophers of Nature

November 1995

## NEWS FROM THE PHILOSOPHERS OF NATURE RESEARCH GROUP

### THE EDITOR'S CORNER

by Russell House

The officers of the association are always pleased to think that our subscribers are making practical use of the lessons and information from the seminars and videos. Our main purpose, that of being of assistance in the evolution of individuals and of humanity at large, can not be realized by distributing educational materials. While this activity is a means to an end, we can only hope that the seeds that we sow fall on fertile ground. That ground is the heart and minds of those who are seeking for a practical way to progress in their own evolutionary path. Our function is to present various tools, techniques, and suggestions which encourage individual endeavor, and which lead to some personal revelation.

For this reason we are always excited when a member shares information that they have gained from their own labor and hard work. This not only speaks of their ingenuity and persistence in overcoming the various obstacles to their work, whether alchemical or qabalistic, but also speaks of their generosity of heart. In the end, it may well be that it is what we carry in our hearts will be our treasure, and that which we share with others will be our legacy of love. I think that our intellectual achievements will pale in comparison to this life of the heart.

With this in mind, I want to discuss a delicate subject. In the past issue, Number 12, of *The Stone*, one of our members shared some information on making a retort for distillation of mercury amalgams. I think that the

ingenuity and generosity are both exceptional, and we hope that there will be more articles like this, from the member and from others.

Because the retort is designed for metallic mercury, it is quite necessary that some comments be made which were not included with the article when it was originally printed. As an association, we recognize that we are obligated to the readers to consider their safety and well being. We realize that experienced workers in metallic alchemy, such as the author of the article, are able to deal with problems of toxic vapors and that they make the necessary arrangements to deal with the problems safely. Since the majority of our readers are not experienced, we want to make certain that no one is poisoned or injured for lack of complete information.

The article, *A Homemade Retort for Mercury Distillation*, says that "For a receiver, I use a empty bottle of about a quart capacity. I fill the bottle with about 8 ounces of water and place the 1/2 tubing into the mouth of the bottle so that it almost touches the water. While

*I do not seal the connection of the bottle and the tubing, it may be done if you chose to with a little ingenuity."*

In this case, the mercury vapors are not being trapped in water, and there is no seal to prevent their escape into the air. Unless this is done

**Mercury in all forms is extremely dangerous. There are always risks involved in working with it, and it is foolish to ignore the dangers. Mercury paths in Alchemy can only be suitable for well equipped and well informed researchers. If you want information on mercury dangers, please send an S.A.S.E. to the Winfield address, and request the article Mercury - A Dangerous Trickster, which was formerly printed in Ora Et Labora, July, 1994. There is no charge for this reprint.**

## ORA ET LABORA

2

outside with moving air, or under a well designed fume hood, this is a very dangerous practice.

One modification that could be made is to put a deep (over 6") "U"-shaped bend in the tubing about 18 inches from the retort, and to fill it with some water so that the vapors are minimized. In this case the distilled mercury will settle in the bottom of the "U" bend. **After the retort has completely cooled**, one could carefully decant the distilled mercury and water. In this case no receiver other than the "U"-tube is used. I consider this to be a borderline solution at best.

It would be important to calculate the volume of water and depth of the bend to make certain that the water can not be accidentally siphoned back into the heated retort. This can cause a steam explosion, or at least, a jet of superheated steam being forced from the end of the tubing.

Some problems when using metal retorts for mercury distillation are cited *in Recovery and Refining of Precious Metals*, by C. W. Ammen, Van Nostrand Reinhold, ISBN-0-442-200934-7:

*"Home-made retorts, however, unless very carefully made on the basis of a good leak proof design, are very dangerous. The same goes for mercury condensers. The old pipe and pipe cap home-brew retorts, along with the potato retort of the old prospectors, are excessively dangerous.*

*"The most common problems are using a retort that is improperly sealed (and leaks) and opening the retort too soon, with your nose in the path of the mercury fumes.*

*"A more serious problem can result from having the discharge from the condenser immersed in water in the catch bowl. When the condenser starts to cool, a vacuum forms in the retort, drawing water into it, with a resulting explosion that under the right conditions is as violent as a hand grenade." Spoken like a man who has been there.*

Having said this, I want to point out once again that I have met the author of the article, and know that he has many years of experience in this work. I am certain beyond doubt that he has used a retort of this design without any big problems, or he would not have shared the information! Still, I want to caution anyone who is even thinking about using this design. **If you are in doubt, don't.**

I hope that my friend will continue to share more of their ideas on the work. I know that he has made other unique solutions to some major problems, and I am certain that these can be of benefit to those who are working on this path.

*Elixir*

*The very word conjures up a world of mystery - of vitality, power, even longevity...*

We invite you to a practical workshop on the preparation of herbal medicines for body and spirit. Learn of the age old methods that enhance the healing power of plants, the ways used by the alchemists that you can easily do in your own home.

Date: Saturday and Sunday, November 18-19, 1995 from 9:30 AM until 4:00 PM

Place: Winfield, Illinois - west of Chicago. Directions given at time of registration.

Price: \$50.00 per person, couples \$85.00. Visa/MasterCard accepted.

Lunch: Bring your own or go to one of the convenient local restaurants

Instructors: Sue House, R.N., Etienne Cornaille, Russ House

For Registration and Info:

Call Sue House, (708) 665-1417.

Weekdays 5-10 PM, weekends 10 AM-10 PM.



## 3

**Rolling the Stone...**

by Russ House

A member who is researching the Flamel Path has had to solve the numerous technical problems that this method presents. I remember her sense of triumph when she finished making her home made furnace and produced a starry regulus of antimony. They asked that we share with our readers their design for a rolling mill frame.

This is a useful tool for mixing the lunar regulus or lunar-venusian regulus of antimony with metallic mercury. It not only saves wear and tear on the elbows and wrists, but also makes it possible to avoid exposure to dangerous mercury vapors during the mixing.

This member has used their ingenuity to design and build a frame that can be used to rotate the mixture for the amalgam in a sealed container with a number of steel ball bearings. Some background information will help you to understand the function of the mixer.

The design is based on that of a laboratory jar mill. The purpose of a mill is to grind materials. In the commercial mills, the grinding portion itself consists of a specially made porcelain jar which is rotated on its long axis as it rests on the two rollers, and which is filled with a grinding medium and the material to be ground. The grinding media can be flint pebbles or porcelain or steel balls. Typically they range from 1/2" to 1" in diameter.

As the mill rotates on the motor driven frame the balls pulverize and mix the materials. The rotation speed can range from 65 up to 320 r.p.m. Commercial units typically use a 1/6 to 1/4 h.p. electrical motor.

These units are quite expensive to purchase. A simple jar mill can cost \$1,000. A jar with a 10 oz. capacity can cost \$300. The jars are quite

**ORA ET LABORA**

specialized in that they are made of porcelain or alumina with a ground cover and gasket to assure a tight seal. The cover of the jar is locked to the body of the jar by means of a clamping cross bar that is tightened with a thumbscrew.

For amalgam, a mix of several sizes of steel balls, 2 or 3 each of various sizes from 0.5" to 1.5" has been found to be effective.

**Making a Frame for a Rolling Mill  
by a Member****Materials:**

- 1 vacuum cleaner belt
- 2 wooden rolling pins
- 2 pieces of 2x4" lumber 15" in length
- 2 pieces of 3/4" plywood cut to 8 x 4"
- 4 2" metal corners with screws
- 1 small electric fan

**Assembly:**

- 1) Put two notches on the 8" side of both pieces of plywood to allow the handles of the rolling pins to fit snugly. Make sure to place the rolling pins far enough apart to allow the mill to be stable as it turns. See Figure 1, a side view of the plywood piece.
- 2) Screw the corners into the 4" ends of the plywood, centering them.
- 3) Butt the end of the plywood up to the inside end of the 2x4 and screw the corner to it. Proceed like this for the other corners. See Figure 2.
- 4) Place the vacuum cleaner belt over one rolling pin and put the rolling pins into the frame with the handles in the notches. See Figure 3 which shows a top view with the rolling pins placed in the frame. The corners go on the inside of the frame.

4

ORA ET LABORA

- 5) Take the guard and blades off of the electric fan. Put the other end of the vacuum belt on the sprocket of the fan. Put a cap or plug on the end of the sprocket to keep the vacuum belt in place.
- 6) Make necessary adjustments for optimum pull on the rolling pin.

**Another Mixer Design:  
by LPN France, 1992**

It is possible to make a mixer for amalgam with stainless steel mixing bowls, some plywood, an electric motor and lots of ingenuity. See figure 4 for a mixer made by Etienne Cornaille for a Canadian seminar in 1992. The diagram shows a frame made from plywood and 2x4" lumber, with circles of plywood and threaded metal rod to act as a clamp and fix the smaller mixing bowl to the motorized axle. The bowl is sealed against either plywood or a metallic cover, and clamped against a silicone joint. This is important to avoid dust and mercury fumes from escaping during the mixing.

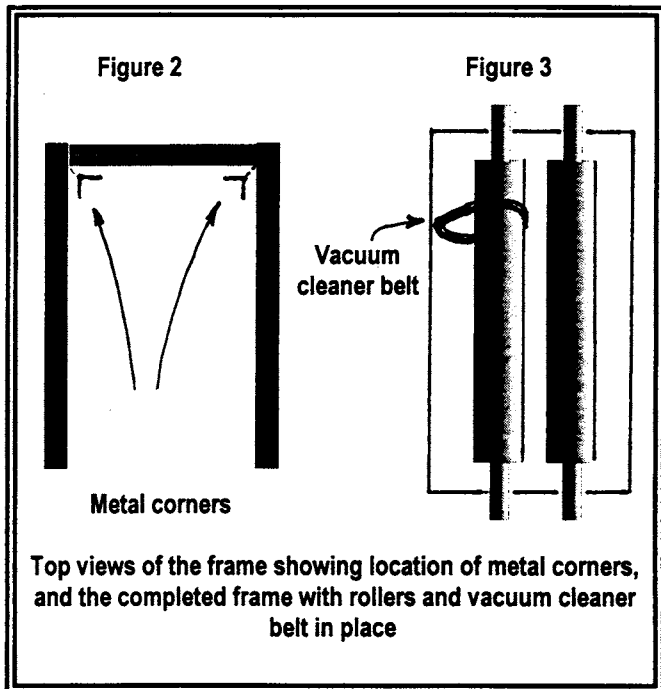
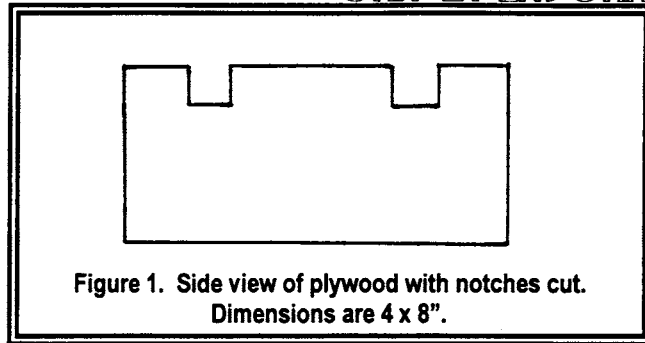

Figure 4 - LPN Designed Amalgam Mixer



*The ideal teacher guides his students but does not pull them along; he urges them to go forward and does not suppress them; he opens the way, but does not take them to the place.* Confucius

path to gnosis as featured in Albrecht Durer's engraving of 1514. Another night was occupied by Michael Maier's alchemical music from Atalanta Fugiens performed by local Czech musicians and singers. Hana Kolvich gave a passionate evening presentation on Czech History defying frustration from a sabotaged slide show. We also enjoyed a day trip to Rudolph II's alchemical laboratory at Prague castle; and visited the actual site of the Battle of White Mountain, lead by Ralph White who's genius inspired and produced this conference.

The late night-early morning hours we spent at a local village pub that became an unintentional site of enthusiastic dialogue on topics presented earlier in the day. For a moment, the INVISIBLE COLLEGE had become visible. This concept was brilliantly described by Anthony Rooley in the third issue of Alexandria, as the imaginal realm of "self-examination" where ancient knowledge is made present in a higher inspired state of mind. Jean Dubuis, the contemporary French alchemist mentions a vaguely similar practice as "Night School". These notions might be related to the medieval idea of "the communion of saints" not as blind faith but as actual guiding contemplative experience. Hesse's Steppenwolf encountered the same experience as "The Magic Theater". Joscelyn Godwin has taken on the Herculean task of writing the annals of the INVISIBLE COLLEGE for Lapis, the magazine of the NEW YORK OPEN CENTER.

Three gems of understanding unfolded themselves during these enchanted days. First, the process occurring in the alchemist's hermetically sealed vase, illustrated so artfully in the 1550 ROSARIUM woodcuts is the same process described in the Tibetan and Egyptian Books of the Dead. Hermes calls it simply "the operation of the sun". Secondly, recent discoveries by Stan Tenen and others on the geometric revelation hidden in the Torah's Hebrew letter code that model mathematically the fractal process of a seed's germination into fruit containing self-propagating seed within itself, illuminates the alchemical gesture of projection. During this gesture rearrangement of base metal subatomic particles catalyzed by the propagated potency of Divine Presence unfolding flower-like from the Philosopher's Stone, creates a well known wonder of alchemy. Thirdly, during Warren Kenton's (a.k.a. Z'ev Ben Shimon Halevi) workshop the realization dawned that even this wonder of alchemy is only a pedestrian token on our journey back to the Divine Source. My sentiments summarized themselves in the mood of Gustave Dore's final engraving for the Divine Comedy, "The Empyrea", captioned: "In the fashion then as a snow white rose...the saintly host displayed itself" (Pra.XXXI, 1, 2).

I did not expect to see so many young people at this event. It restored faith and hope in humanity at large. Each of us holds the power and bears the responsibility for a more perfect world. I recall a starlit walk on the castle grounds on the final night of this occasion with a beautiful young woman who filled the pristine air with cigarette smoke and nervous chatter. After a long mystic silence she finally confessed her impression that a wedding really had taken place.

[This essay was completed on ALL SOULS DAY 1995]



## "Who Do I Contact When..."

I have questions about my membership?"

I have problems receiving my lessons?"

I would like to subscribe to The Stone?"

I need back issues of The Stone?"

Write or call the administrative headquarters: Philosophers of Nature, 125 West Front St., Suite 263, Wheaton, IL 60190; Phone (708) 665-1417 between 9am & 5pm Central Time, Monday through Friday.

I have an article or letter for The Stone?"

I have advertising for The Stone?"

Write, call, or e-mail the editor: The Stone c/o Ken Miller, 405 West Washington Street #314, San Diego, CA 92103-1994. Phone (619) 528-4521 (keep in mind Pacific Time). E-mail: StonePON@aol.com

**Please Note: MAILING YOUR INQUIRY TO THE WRONG ADDRESS COULD DELAY MATTERS FOR MONTHS.**

## • About The Stone

The Stone is published three times a year in March, July, and November, primarily for the benefit of the membership of the Philosophers of Nature. We hope to get members' feedback regarding what they would like to see in it. Articles, photographs, drawings, letters to the editor, and comments from members or others are solicited for submission to the Editor for evaluation. Submissions and advertising should be sent to The Stone c/o Ken Miller, 405 West Washington Street, Suite 314, San Diego, California 92103-1994. E-mail may be sent to StonePON@aol.com. Deadline for submissions and advertising are as follows: February 20th for the March issue; June 25th for the July issue; October 25th for the November issue.

## • Advertising

The Stone accepts advertising for both display and classified ads. Rates are as follows: Full page: \$100.00; Half page: \$60.00; Quarter page \$35.00; Classified ads are \$0.10 per word. For more information write the editor, Ken Miller at the address listed above, or e-mail him at StoneLPN@aol.com

## • Subscription to The Stone & Membership Information

The Stone is included in the cost of membership. Non-members may subscribe at the rate of \$20 per year (three issues). Subscription requests and any questions about membership should be sent to the administrative headquarters: Philosophers of Nature, 125 West Front Street, Suite 263, Wheaton, IL 60190. You may leave a message for the office manager at (708) 665-1417 from 9am to 5pm Central Time.