

BOOK No 6

Revision 0



# PROTECTION APPLICATION HANDBOOK



# ABB

**BA THS / BU Transmission Systems and Substations**

**LEC Support Programme**

**Suggestions for improvement of this book  
as well as questions shall be addressed to:**

BU TS / Global LEC Support Programme  
C/o ABB Switchgear AB  
SE-721 58 Västerås  
Sweden

Telephone	+46 21 32 80 00
Telefax	+46 21 32 80 13
Telex	40490 abbsub s

Copyright © BU Transmission Systems and Substations

# Protection Application Handbook

Welcome to the Protection Application Handbook in the series of booklets within the LEC support programme of BA THS BU Transmission Systems and Substations. We hope you will find it useful in your work. Please note that this is an advance copy that was used by ABB Substations in Sweden. The handbook will be modified to better suit into the engineering documentation planned to be issued in cooperation with the Global process owner Engineering.

The booklet covers most aspects of protection application based upon extensive experience of our protection specialists like:

- Selection of protection relays for different types of objects.
- Dimensioning of current and voltage transformers matching protection relays requirements.
- Design of protection panels including DC and AC supervision, terminal numbering etc.
- Setting of protection relays to achieve selectivity.
- Principles for sub-division of the protection system for higher voltages.

The booklet gives a basic introduction to application of protection relays and the intent is not to fully cover all aspects. However the basic philosophy and an introduction to the application problems, when designing the protection system for different types of objects, is covered.

The intention is to have the application as hardware independent as possible and not involve the different relay types in the handbook as the protection relays will change but the application problems are still the same.

The different sections are as free standing sections as possible to simplify the reading of individual sections. Some sections are written specially for this handbook some are from old informations, lectures etc. to bigger or smaller extent.

# Content

<i>Section</i>	<i>Page No</i>
Network General	5
Fault calculation	23
Network earthing	51
Protection General	83
Protection Line	97
Protection Transformer	163
Protection Reactors	175
Protection Capacitors	185
Protection Bus and Breaker	189
Earth Fault protection	203
Current transformers	235
Voltage transformers	249
Requirement on current transformers	263
Control System structure	275
Protection settings	301
Sub divided systems	341

# Network General

## 1. TRANSMISSION LINE THEORY

### 1.1 GENERAL

For a long power line, symmetrical built and symmetrical loaded in the three phases, voltage and current variation along the line can be expressed as shown in fig. 2, with corresponding formulas. In these formulas the propagation of speed is included as a variable.

The propagation of speed can be calculated according to:

$$\gamma = \sqrt{(R + jX)(G + jB)} = \sqrt{ZY}$$

where “**R**”, “**X**”, “**G**” and “**B**” are the resistance, reactance, conductance and susceptance per phase.

Surge impedance is defined as:

$$Z_V = \sqrt{\frac{R + jX}{G + jB}} = \sqrt{\frac{Z}{Y}}$$

For lines without losses the above formulas become:

$$\gamma = j\omega\sqrt{LC} = j\sqrt{XB} = j\beta$$

$$Z_V = \sqrt{\frac{X}{B}} = \sqrt{\frac{L}{C}}$$

The values of “**X**” and “**B**” can approximately be calculated from the geometrical data of the power line according to the following formulas:

$$L = 2 \times 10^{-4} \ln\left(\frac{2H}{R_{ekv}}\right) \text{ H/km}$$

$$C = \left( \frac{10^{-6}}{18 \ln \left( \frac{2H}{R_{ekv}} \right)} \right) \text{F/km}$$

where:

“H” is the phase conductors height over earth

“ $R_{ekv}$ ” is the phase conductor equivalent radius. To determine the equivalent radius see fig. 1.

The surge impedance is accordingly obtained as:

$$Z_v = 60 \ln \left( \frac{2H}{R_{ekv}} \right)$$

For single conductors, “ $Z_v$ ” is approximately 360-400 ohm per phase. For duplex conductors, “ $Z_v$ ” is approximately 300-320 ohm per phase.

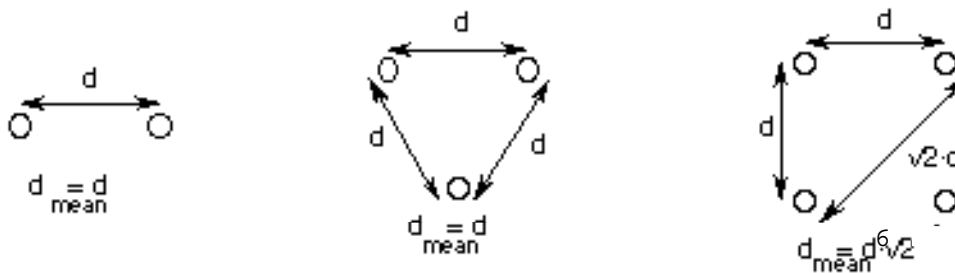

Figure 1. Different conductor configurations.

The equivalent radius  $R_{ekv}$  will be:

$$R_{ekv} = \sqrt[n]{R \times d_{mean}^{n-1}}$$

where “n” is the number of conductors per phase.

# Network General

If the voltage “ $U_2$ ” and the current “ $I_2$ ” at the receiving side is given, the voltage at a distance “ $s$ ” km from the supplying side (see fig. 2) is given as:

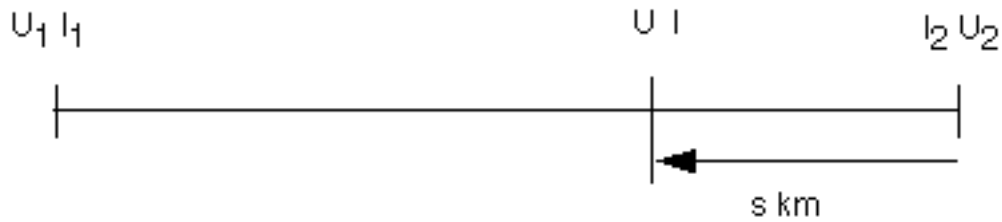

Figure 2. Voltage distribution along a line.

$$U = U_2 \cos \beta s + Z_V I_2 \sin \beta s$$

$$I = j \frac{U_2}{Z_V} \sin \beta s + I_2 \cos \beta s$$

## 1.2 POWER LINE AT NO LOAD, $I_2 = 0$

Voltage and current along the line are following a cos- respectively a sinus curve. The voltage as well as the current have the same phase angle along the whole line. The phase angle between the voltage and current is  $90^\circ$ .

$$U_2 \approx U_1 \times \frac{1}{\cos(0.06 \times l)^\circ} \quad \text{at 50Hz}$$

$$U_2 \approx U_1 \times \frac{1}{\cos(0.072 \times l)^\circ} \quad \text{at 60Hz}$$

where “ $l$ ” is the line length in km.

It must also be considered that “ $U_1$ ” increases when the line is connected to a network.

$$\Delta U_1 \approx \frac{Q_c}{S_{\text{sh.c.}}}$$

---

## TRANSMISSION LINE THEORY

where:

“ $Q_c$ ” is the capacitive power generated by the line and

“ $S_{sh.c.}$ ” is the short-circuit power of the network.

The capacitive power generated by the power line can be calculated as:

$$Q_c = \frac{U^2}{X_c}$$

Where “ $U$ ” is the rated line voltage and “ $X_c$ ” is the capacitive reactance of the power line.

### 1.3 POWER LINE SHORT-CIRCUITED, $U_2 = 0$

For this case the voltage follows a sinus curve and the current follows a cosines curve i. e. opposite to when the power line is at no load.

### 1.4 POWER LINE AT LOAD

At “surge impedance” load “ $U_2 = Z_v I_2$ ” the reactive power produced in the shunt capacitance of the line is same as the reactive power consumed by the reactance along the line. The following balance is obtained:

$$\omega C \times U_2 = \omega L \times I^2 \Rightarrow \frac{U}{I} = \sqrt{\frac{L}{C}} = Z_v$$

If the active losses of the line is neglected the following conditions are obtained for different load conditions:

- If the transferred active power is less than the “*surge impedance*” load and no reactive power is taken out at the receiving end, the voltage will be higher at the receiving end than the voltage at the sending end. If voltage is kept equal at both ends, the voltage will be higher at the middle of the line.
- If the transferred active power is higher than the “*surge impedance*” load and no reactive power is taken out at the receiving end, the voltage will be lower at the receiving end than the voltage at the sending end. If the voltage is kept equal at both ends, the voltage will be lower at the middle of the line.

---

## TRANSMISSION LINE THEORY



# Network General

In reality these conditions are modified a little due to the resistance of the line. This will give a small voltage drop in the same direction as the active power flow.

The “surge impedance load” is normally only considered for very long transmission lines at very high voltages. For these cases the actual power should not deviate too much from the “surge impedance” load considering losses on the line, voltage fluctuation and the availability of reactive power in the network.

In most cases, technical and economical aspects rules what power that is to be transmitted over the line.

As a general guidance for “surge impedance load” you can assume approximately 120 MW for a 220 kV line with a single conductor and 500 MW for a 400 kV line with duplex conductors.

## 2. VOLTAGE DROP AND LOSSES IN POWER SYSTEMS. SHORT LINES (<50 KM)

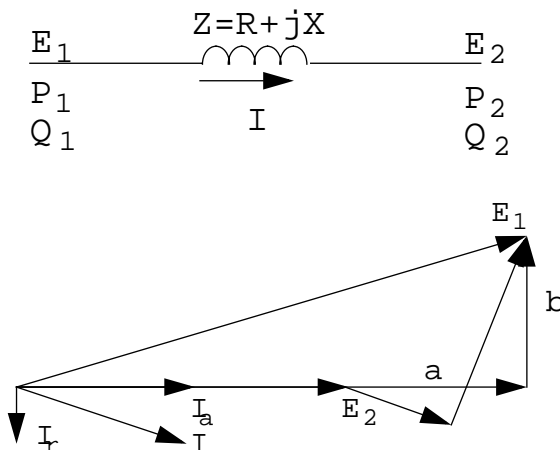

Figure 3. Load transfer on a short line.

---

### VOLTAGE DROP AND LOSSES IN POWER SYSTEMS.

## 2.1 VOLTAGE, REACTIVE AND ACTIVE POWER KNOWN AT THE RECEIVING END

The impedance for short lines can be expressed as “ $Z=R+jX$ ”, see fig. 3. The voltage drop can be split into two components, one in the same direction as “ $E_2$ ”, named “ $a$ ” and one perpendicular to “ $E_2$ ”, named “ $b$ ”.

$$a = \frac{1}{E_2}(R \times P_2 + X \times Q_2)$$

$$b = \frac{1}{E_2}(X \times P_2 + R \times Q_2)$$

$$E_1 = \sqrt{(E_2 + a)^2 + b^2}$$

This means that if the voltage, the active and reactive power are known at the receiving end, the voltage at the sending end can be easily calculated.

For short lines, “ $b$ ” will be small compared with the voltage and it is possible to make the approximation “ $E_1 = E_2 + a$ ”.

If “ $b$ ” is less than 10% of “ $E_2 + a$ ”, the error when calculating “ $E_1$ ” is less than 0.5%.

The active and reactive losses  $P_f$  and  $Q_f$  on the line can be expressed as:

$$P_f = 3R \times I^2 = R \times \frac{P_2^2 + Q_2^2}{E_2^2}$$

$$P_1 = P_2 + P_f$$

$$Q_f = 3X \times I^2 = X \times \frac{P_2^2 + Q_2^2}{E_2^2}$$

---

VOLTAGE DROP AND LOSSES IN POWER SYSTEMS.

# Network General

$$Q_1 = Q_2 + Q_f$$

## 2.2 VOLTAGE, REACTIVE AND ACTIVE POWER KNOWN AT THE SENDING END

If the voltage, the active power and the reactive power are known at the sending end the following equations are valid:

$$a = \frac{1}{E_1}(R \times P_1 + X \times Q_1)$$

$$b = \frac{1}{E_1}(X \times P_1 + R \times Q_1)$$

$$E_2 = \sqrt{(E_1 - a)^2 + b^2}$$

For short lines “b” will be small compared with “ $E_1 - a$ ” and the approximation “ $E_2 \approx (E_1 - a)$ ” can be done in the same way as when the voltage, the active and reactive power are known at the receiving end.

The losses on the line can be expressed as:

$$P_f = 3R \times I^2 = R \times \frac{P_1^2 + Q_1^2}{E_1^2}$$

$$Q_f = 3X \times I^2 = X \times \frac{P_1^2 + Q_1^2}{E_1^2}$$

$$P_2 = P_1 - P_f$$

$$Q_2 = Q_1 - Q_f$$

---

VOLTAGE DROP AND LOSSES IN POWER SYSTEMS.

## 2.3 VOLTAGE KNOWN AT SENDING END, REACTIVE AND ACTIVE POWER KNOWN AT THE RECEIVING END

The cases when the voltage at the sending end and the reactive and active power at the receiving end are known is quite common. The calculation will in cases like these be a little more complicated and trial calculation is the best way. The voltage at the receiving end is assumed “ $E'_2$ ” and from this value a voltage “ $E'_1$ ”, at the sending end is calculated. The calculated value “ $E'_1$ ” is subtracted from the given value “ $E_1$ ” and the difference is added to the previous guessed “ $E'_2$ ” value to get a new value.

$$E''_2 = E'_2 + E_1 - E'_1$$

The nominal sending end voltage can normally be assumed as the first guessed value of “ $E'_2$ ”.

## 2.4 REDUCTION OF THE VOLTAGE DROP

For a power line at a certain load there are some possibilities to reduce the voltage drop:

- Keeping the service voltage as high as possible.
- Decreasing the reactive power flowing through the line by producing reactive power with shunt capacitors at the load location.
- Reducing the inductive reactance of power lines with series capacitors.

## 3. REPRESENTATION OF LONG POWER LINES(>50 KM)

Long power lines are usually represented with a p-link, see fig. 4.

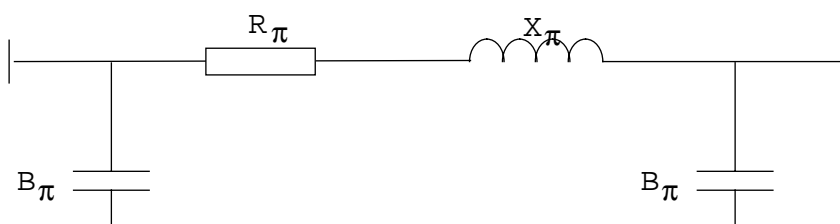

REPRESENTATION OF LONG POWER LINES(>50 KM)

# Network General

Figure 4. The equivalent  $\pi$  representation of a line.

where:

$$R_{\pi} = R \left( 1 - \frac{1}{3}XB \right)$$

$$X_{\pi} = X \left( 1 - \frac{1}{6}XB \right)$$

$$B_{\pi} = \frac{1}{2}B \left( 1 + \frac{1}{12}XB \right)$$

This scheme can be used up to 200 km length without long line correction, which is the second term in the equation above. The calculation error is then about 1.5% in resistance, 0.75% in reactance and 0.4% in susceptance.

If the corrections are used the scheme above can be used up to 800 km line length. The calculation error is then about 1.0% in resistance and 0.5% in reactance.

The values of “**X**” and “**B**”, can be calculated from the geometrical data, see formulas for L and C in the beginning of the chapter.

## 4. SYNCHRONOUS STABILITY

### 4.1 ONE GENERATOR FEEDING A “STRONG” NETWORK

Assume that one generator is feeding a strong network through a line, see fig. 5.

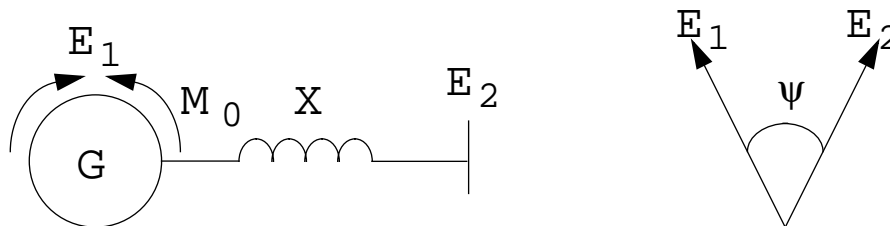

Figure 5. Generator feeding a “strong” network.

$$P = \frac{E_1 E_2}{X} \sin \psi$$

$$\omega J \frac{d^2 \psi}{dt^2} = P_0 - P_{\max} \times \sin \psi$$

$$J \frac{d^2 \psi}{dt^2} = M_0 - M_{\max} \times \sin \psi$$

Where “ $\omega$ ” is the angular frequency, “ $2\pi f$ ” and “ $J$ ” are the angular momentum.

The differential equation becomes possible to solve if the transferred power, during the fault is zero.

$$\frac{d^2 \psi}{dt^2} = \frac{P_0}{\omega J} \Rightarrow \frac{d\psi}{dt} = \frac{P_0}{\omega J} \times t + A \Rightarrow \psi(t) = \frac{P_0}{\omega J} \times \frac{t^2}{2} + A \times t + B$$

For steady state condition the derivative of the angle is zero i. e. there is balance between the produced and transmitted power. This gives “ $A$ ”=0.

The angle for “ $t=0$ ” gives “ $B=\psi_0$ ”.

---

### SYNCHRONOUS STABILITY

# Network General

The inertia constant “H” of a generator is defined as:

$$H = \frac{1}{2} \frac{\omega^2 \times J}{S_n} \Rightarrow \omega J = \frac{2 \times S_n \times H}{\omega}$$

Inserting these values gives the following equation:

$$\psi(t) = \frac{\omega \times P_0}{2 \times S_n \times H} \times \frac{t^2}{2} + \psi_0$$

If the transferred power during the fault is not zero the equal area criteria has to be used for checking the stability.

## 4.2 EQUAL AREA CRITERIA FOR STABILITY

A power station feeds power to a strong network through two parallel lines, see fig. 6.

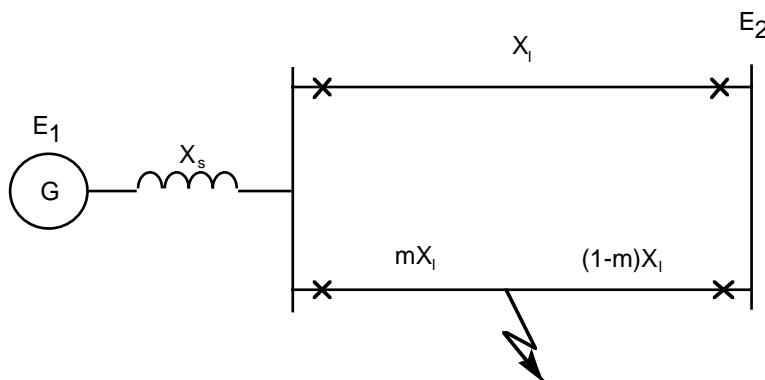

Figure 6. Line fault on one circuit of a double Overhead line.

When a three phase fault occur on one of the lines, the line will be disconnected by the line protection.

The question is whether the synchronous stability is maintained or not.

---

## SYNCHRONOUS STABILITY

Before the fault, the maximum transferred power is:

$$P_{\max} = \frac{E_1 \times E_2}{X_s + \frac{X_l}{2}}$$

During the primary fault the reactance between the generator and the strong network will be:

$$X_s + X_l + \frac{X_s X_l}{m X_l} = X_s \left(1 + \frac{1}{m}\right) + X_l$$

this is obtained by an “**Y-D-transformation**” of the system (see fig. 7).

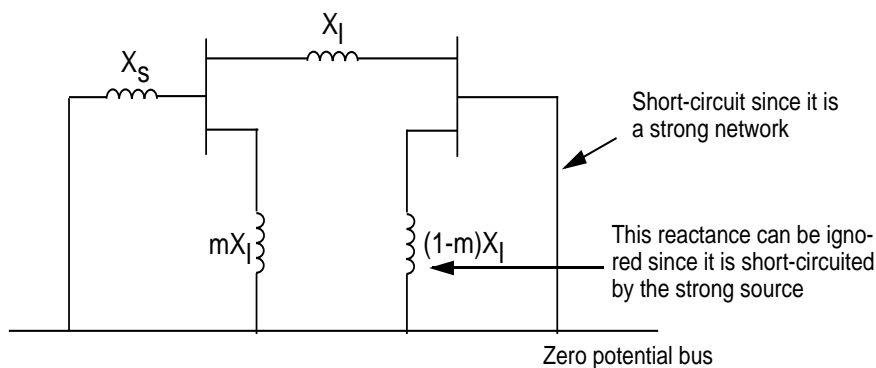

Figure 7. Thevenin's theorem applied on the faulty network.

Maximum transferred power during the fault is:

$$P'_{\max} = \frac{E_1 \times E_2}{X_s \left(1 + \frac{1}{m}\right) + X_l}$$

The power transfer during the fault is therefore limited. Maximum power can be transmitted when “**m**”=1, i. e. a fault close to the strong network. For faults close to the generator “**m**”=0 and no power can therefore be transmitted during the fault.

When the faulty line has been disconnected the maximum transferred power will be:

$$P''_{\max} = \frac{E_1 \times E_2}{X_s + X_l}$$

---

## SYNCHRONOUS STABILITY



# Network General

The maximum transferred power after that the fault has been cleared will be:

$$0.5P_{\max} < P''_{\max} < P_{\max}$$

In fig. 8 the active power that can be transferred during the different conditions is shown.

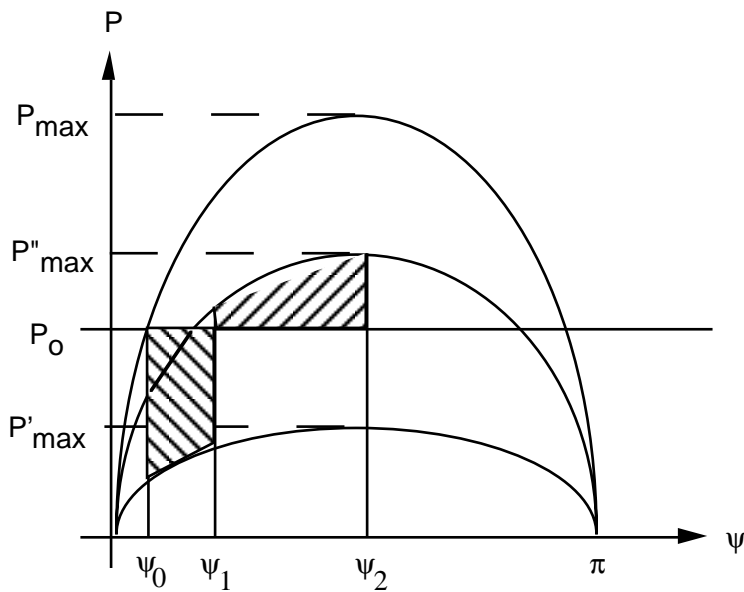

Figure 8. The equal area method shows the stability limit.

The following equation is valid when the two areas in the figure above are equal:

$$\int_{\psi_0}^{\psi_1} P_0 - P'_{\max} d\psi = \int_{\psi_1}^{\psi_2} P''_{\max} - P_0 d\psi$$

The angle is increasing from “ $\psi_0$ ” to “ $\psi_1$ ” during the fault. For the worst condition when “ $m$ ”=0 the accelerated power is constantly equal to “ $P_0$ ” during the fault.

If the area below “ $P_0$ ” (see the dashed area in fig. 8) is smaller than the maximum area between “ $P_0$ ” and the curve with “ $P''_{\max}$ ” as maximum the system will remain stable.

In fig. 8 the area above “ $P_0$ ” equal to the area below “ $P_0$ ” is dashed which shows that the system will remain stable for the case shown in fig. 8.

---

## SYNCHRONOUS STABILITY

## 5. ACTIONS TO IMPROVE THE STABILITY

This matter could be looked into from two different aspects, either to increase the stability at a given transferred power or to increase the transferred power maintaining the stability.

**MORE THAN ONE PHASE CONDUCTOR PER PHASE**

decreases the reactance of the line and thus the angle between the line ends at a given transferred power, or it can increase the power transferred with maintained stability. If the reactance is 100% with one conductor per phase it will become approximately 80% with 2 conductors, 70% with three conductors and 65% with four conductors.

Multiple phase conductors reduces the electric field strength at the surface of the conductors. This makes it possible to have a higher voltage without getting corona.

**SERIES CAPACITORS ON OVERHEAD LINES** reduces the reactance between the stations. The compensation factor “**c**” is the ratio between the capacitive reactance of the capacitor and the inductive reactance of the overhead line. The power transfer can be doubled if a compensation factor of 30% is used.

**SHORT FAULT CLEARING TIME** makes the increase of the angle between the two systems at an occurring primary fault smaller. The angle increase is proportional to the time in square.

**SINGLE POLE AUTORECLOSING** allows the two healthy phases to transfer power even during the dead interval. For lines longer than approximately 350 km it is then necessary to include four leg reactors to extinguish the secondary arc due to the capacitive coupling between the phases.

**INCREASED INERTIA CONSTANT IN THE GENERATORS** makes the maximum allowed fault clearance time to increase proportional to the square root of the inertia constant increase. The allowed power transfer can also be increased with maintained fault clearance times.

---

### ACTIONS TO IMPROVE THE STABILITY

## 6. SHUNT REACTORS

Shunt reactors are used in high voltage systems to compensate for the capacitive generation from long overhead lines or extended cable networks.

The reasons for using shunt reactors are two. One reason is to limit the overvoltages, the other reason is to limit the transfer of reactive power in the network. If the reactive power transfer is minimized, i.e. a better reactive power balance in the different part of the networks a higher active power can be transferred in the network.

Reactors for limiting overvoltages are mostly needed in weak power systems, i.e. when the network short circuit power is relatively low. The voltage increase in a system due to the capacitive generation is:

$$\Delta U(\%) = \frac{Q_c \times 100}{S_{sh.c.}}$$

where

“ $Q_c$ ” is the capacitive input of reactive power to the network and “ $S_{sh.c.}$ ” is the short circuit power of the network.

With increasing short circuit power of the network the voltage increase will be lower and the need of compensation to limit the overvoltages will be less accentuated.

Reactors included to get a reactive power balance in the different part of the network are most needed in heavy loaded networks where new lines can't be built out of environmental reasons. The reactors then are mostly thyristor controlled in order to adopt quickly to the required reactive power.

Four leg reactors can also be used for extinction of the secondary arc at single-phase reclosing in long transmission lines, see fig. 9. Since there always is a capacitive coupling between the phas-

---

### SHUNT REACTORS

es this will keep the arc burning (secondary arc). By adding one single-phase reactor in the neutral the secondary arc can be extinguished and the single-phase auto-reclosing successful.

## **7. REACTORS FOR EXTINCTION OF SECONDARY ARC AT AUTO-RECLCLOSING**

It is a known fact that most of the faults in overhead lines are of single phase type. It is therefore possible to open and reclose only the faulty phase and leave the other two phases in service. The advantage with this is that the stability of the network is improved since the two remaining phases can transmit power during the auto-reclosing cycle. This is of special interest for tie lines connecting two networks, or part of networks.

Due to the capacitive coupling between the phases the arc at the faulty point can be maintained and the auto-reclosing consequently would be unsuccessful. With a dead interval of 0.5 seconds, line lengths up to approximately 180 km can be reclosed successfully in a 400 kV system. This with the assumption of fully transposed lines. Should the line be without transposition the line length with possible successful single-phase auto-reclosing would be about 90 km. If the dead interval is increased to 1.0 second the allowed lengths will be approximately doubled.

For successful auto-reclosing of lines longer than above it's necessary to equip the line with Y-connected phase reactors at both ends, combined with "neutral" reactors connected between the Y-point and earth. This solution was first proposed in 1962 by professor Knudsen the reactor are therefore also called Knudsen reactor but it can also be called teaser reactor.

The teaser reactors inductance is normally about 26% of the inductance in the phases. The maximum voltage over the teaser reactor then becomes approximately 20% of nominal voltage phase/earth. The current through the teaser reactor during a single-phase auto-reclosing attempt is about the same as the rated current of the phase reactors. The duration of the dead interval is usually 0.5-1 second. In normal service currents through a teaser

---

### REACTORS FOR EXTINCTION OF SECONDARY ARC AT

# Network General

reactor is only a few amperes due to possible small unsymmetry in the phase voltages and differences between the phase reactors.

Because of the low powers and voltages in the teaser reactor the reactor can be made very small compared with the phase reactors. The extra cost to include the teaser reactor compared to the “normal” shunt reactor cost is therefore not so large.

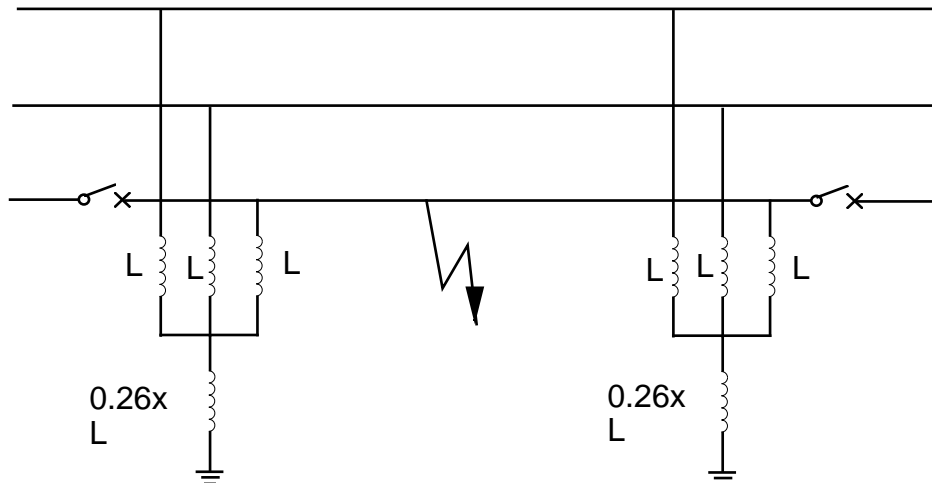

Figure 9. Single pole fault clearance on a power line with teaser reactors to extinguish the arc.

---

## REACTORS FOR EXTINCTION OF SECONDARY ARC AT

# Fault Calculation

## 1. INTRODUCTION

Fault calculation is the analysis of the electrical behavior in the power system under fault conditions. The currents and voltages at different parts of the network for different types of faults, different positions of the faults and different configurations of the network are calculated.

The fault calculations are one of the most important tools when considering the following:

- Choice of suitable transmission system configuration.
- Load- and short circuit ratings for the high voltage equipment.
- Breaking capacity of CB:s.
- Application and design of control- and protection equipment.
- Service conditions of the system.
- Investigation of unsatisfactory performances of the equipment.

This description will be concentrated on fault calculations used at application and design of protection equipment.

The major requirements on protection relays are speed, sensitivity and selectivity. Fault calculations are used when checking if these requirements are fulfilled.

**Sensitivity** means that the relay will detect a fault also under such conditions that only a small fault current is achieved. This is e. g. the case for high resistive earth faults. For this purpose fault calculations for minimum generating conditions are performed to make sure that the selected relay will detect the fault also during minimum service conditions.

**Selectivity** means that only the faulty part of the network is disconnected when a fault occurs. This can be achieved through absolute selectivity protection relays (unit protection) or time selective relays. In a network, there is always time selective protection relays as back up protection. To be able to make selective settings of these relays it's necessary to have a good knowledge

---

## INTRODUCTION

of the fault current.

**Speed** means that a limited operating time of the relay is required. For many relays the operating time is depending on the magnitude of the fault current. Thus it is important, when planning the network to have a good knowledge of the fault current. Hereby it's possible to predict the operating time of the relay and thus make sure that maximum allowed fault clearance time is fulfilled under all circumstances.

## 2. FACTORS AFFECTING THE FAULT CALCULATION.

Concerning fault calculations the first thing to do is to decide what case or cases that shall be studied. The fault current and fault voltage at different parts of the network will be affected by the following:

- Type of fault.
- Position of the fault.
- Configuration of the network.
- Neutral earthing.

The different types of faults that can occur in a network, can be classified in three major groups:

- Short circuited faults.
- Open circuited faults.
- Simultaneous faults.

The short circuited faults consists of the following types of fault:

- Three phase faults (with or without earth connection).
- Two phase faults (with or without earth connection).
- Single phase to earth faults.

The open circuit faults consists of the following types of fault:

- Single phase open circuit.
- Two phase open circuit.

---

## FACTORS AFFECTING THE FAULT CALCULATION.



# Fault Calculation

- Three phase open circuit.

Simultaneous faults are a combination of the two groups described above, for example, if one conductor, at an overhead line, is broken and one end of the line falls down. Then there is both one single phase to earth fault and one single phase open circuit fault in the system.

Deciding what fault and how many locations of the fault, that shall be studied, depends on the purpose of the study. If the sensitivity of a differential relay is to be studied, the fault shall be located inside the protective zone. By this, knowledge of the differential current at a fault is achieved. If, on the other hand, selectivity between the inverse time delayed over current relays is to be studied, other fault locations must be selected.

The configuration of the network is of greatest importance when making fault calculations. There will be a big difference, comparing the results, if the calculations are performed at minimum or maximum generating conditions. The result will be affected by how many parallel lines that are in service and if the busbars are connected via bus coupler or not etc.

The large number of conditions that affect the fault calculation makes it practical to have a standard fault condition to refer to, normally the three phase short circuit faults. This short circuit level may be expressed in amperes, or in three phase MVA corresponding to the rated system voltage and the value of the three phase fault current.

## 3. BASIC PRINCIPLES

### 3.1 TIME ASPECT

It is a well known fact that the effects of a fault, changes with the time that has passed since the fault occurred. The physical reason for this transient process is that electromagnetic energy is stored in the inductances of the circuits. This energy can not be

---

#### BASIC PRINCIPLES

altered in an indefinite short time. Therefore some time will pass while the new electrical field is created. These time intervals are known as the sub-transient and transient conditions. The duration of the transient interval is counted in ms. In this case, the fault calculations are intended to be used for application and design of relay equipment. The fastest protection relays have operating times of about 10 ms. When time selectivity is to be investigated the time can vary from 0.3 second up to a few seconds. Therefore fault calculations are made for conditions when the first transient condition “sub transient conditions” have come to an end i.e. the transient reactances of the generators are used.

### **3.2 TYPE OF FAULT**

The task of the protection relays is to protect the high voltage equipment. This is done by a trip signal, given to the circuit breakers, when a fault occurs. The most dangerous phenomena is normally the high current that occurs at a short circuit. When making fault calculations for the purposes here discussed, short circuit type faults are normally considered. Open circuit faults will not cause high Overcurrent or high overvoltages and are therefore normally not dangerous to the network. Open circuit faults will cause heating in rotating machines, due to the “negative sequence current” that will flow in the system. The machines are therefore equipped with negative sequence current protection. The setting of this relay normally needs no fault calculation and can be done correctly without knowledge of the problems mentioned above.

A network is usually protected against phase and earth faults by protection relays. The magnitude of the fault current is dependent on what type of fault that occurs. At earth faults the size of the fault current is depending on the earthing resistance or reactance (if applicable) and on the resistance in fault. The fault resistance for a phase fault is much smaller than that for an earth fault. This shows why fault calculations for earth faults with a specified resistance in the fault normally is recommended.

Three phase faults normally gives the highest short circuit cur-

---

## **BASIC PRINCIPLES**

# Fault Calculation

rents. Therefore short circuit calculations for three phase faults also normally are used.

Two phase faults normally gives lower fault currents than three phase faults, why normally the need for fault calculations for two phase faults is limited. However, a two phase fault calculation can be necessary to check the minimum fault current level to verify the sensitivity for the back-up protection.

## 3.3 DEFINITION

Faults can be divided into two groups, symmetrical (balanced) and unsymmetrical (unbalanced) faults. The symmetrical faults are only concerning three phase faults, all other faults are seen as unsymmetrical.

## 4. BALANCED FAULT CALCULATION

When a balanced fault i.e. a three phase fault occurs, the relation between the phases is maintained. This means that the fault currents and the fault voltages are equal in the three phases. The only difference is the phase angle which will be maintained even during the fault. It is therefore sufficient to use a single phase representation of the network and calculate the fault currents and voltages at one phase. The result will be applicable at all three phases, with the angle ( $120^\circ$ ) maintained between the phases.

The short circuit calculations are easiest done by using Thevenin's theorem which states:

***Any network containing driving voltages, as viewed from any two terminals, can be replaced by a single driving voltage acting in series with a single impedance. The value of this driving voltage is equal to the open circuit voltage between the two terminals before the fault occurs, and the series impedance is the impedance of the network as viewed from the two terminals with all the driving voltages short circuited.***

The two terminals mentioned in the theorem are located at the fault. This way of calculating will only give the change in voltage

---

### BALANCED FAULT CALCULATION

and current caused by the short circuit. To get the correct result the currents and voltages that existed in the system before the fault must be superimposed geometrically to the calculated changes.

The two following simplifications are normally made:

- The same voltage is used in the whole network (voltage drops from load currents are neglected).
- All currents are considered to be zero before the fault occurs, which means that no load currents are considered.

## 4.1 STEP BY STEP INSTRUCTIONS - SHORT CIRCUIT CALCULATIONS

When making three phase short circuit calculations these four steps should be followed:

- 1) Short circuit all E.M.F. s (Electro Motoric Forces) in the network and represent the synchronous machines with their transient reactances.
- 2) Decide one base voltage and transform all impedances into that voltage level.
- 3) Reduce the network to one equivalent impedance.
- 4) If “U” is the selected base voltage and “Z” is the resulting impedance of the network the total short circuit current “ $I_{sc}$ ” in the fault itself, at a three phase short circuit, is:

$$I_{sc} = \frac{U}{Z\sqrt{3}}$$

Clause 1 can be commented as follows:

***It depends on what part of the network that is of interest, how the sources are represented. If the voltages and currents of interest are located not too far from the generator, the synchronous machines should be represented as mentioned. If however the area of interest is far from the generating plants it's normally more convenient to use the short circuit power closer to the fault point as source.***

The four steps are further developed:

---

### BALANCED FAULT CALCULATION

# Fault Calculation

## Representation of the network components

**Overhead lines** are represented by their resistance and reactance.

The positive sequence values are used for phase faults. For earth faults, the zero sequence values are used. Negative sequence components for overhead lines are always equal to the positive sequence components.

The values mentioned, must be given by the constructor of the overhead lines. The values depends on the size of the line itself, as well as on the physical configuration of the lines (both within a phase and between the phases).

For zero sequence impedance, the earth conditions are also of greatest importance. When two or more lines are placed at the same towers, there will be a mutual impedance between the lines. The mutual impedance is only important at earth faults, though it, for phase faults, is that small it can be neglected. Consideration to the mutual impedance must only be taken when earth faults are calculated.

Thumb roles concerning overhead lines:

- For line reactance of a HV overhead line the reactance is about 0.3-0.4 ohm/km at 50 Hz.
- The resistance is normally small (0.02-0.05 ohm/km) and of minor importance to the short circuit calculations.
- The zero sequence reactance is approximately 3-4 times the positive sequence reactance and the mutual reactance is approximately 55-60% of the zero sequence reactance.

One way to describe these values is to give them in%, pu. Then the basic power also will be given.

Example: A 400 kV line “**x**” = **1.76%** and “**S<sub>base</sub>**” = **100 MVA** gives:

$$X = \frac{1.76}{100} \times \frac{400^2}{100} = 28.16 \Omega$$

**Cables** are represented by the same values as the overhead lines, i.e. resistance and reactance. Also here the cable manufac-

---

## BALANCED FAULT CALCULATION

turer must give the data as the values changes with the type of cable. Typically a cable impedance angle is around 45 ° and the zero sequence values are of the same magnitude as the positive sequence values.

**Transformers** are represented by their short circuit impedance. As the transformer is almost entirely inductive, the resistance normally is neglected.

The impedance of the transformer is:

$$X = \frac{z_k}{100} \times \frac{U^2}{S_N}$$

where “ $z_k$ ” is the short circuit impedance. For a three winding transformer there are short circuit impedances between all of the three windings.

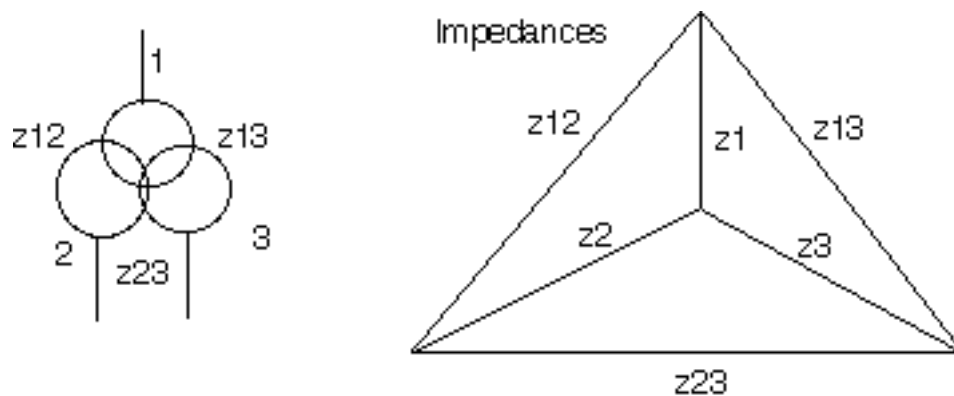

Figure 1. The Star delta impedance transformation is necessary to calculate fault currents when three winding transformers are involved.

In this case the star/triangle transformation is useful.

$$Z_1 = \frac{Z_{12} \times Z_{13}}{Z_{12} + Z_{13} + Z_{23}}$$

$$Z_2 = \frac{Z_{12} \times Z_{23}}{Z_{12} + Z_{13} + Z_{23}}$$

$$Z_3 = \frac{Z_{13} \times Z_{23}}{Z_{12} + Z_{13} + Z_{23}}$$

---

## BALANCED FAULT CALCULATION

# Fault Calculation

$$Z_{12} = \frac{Z_1 Z_2 + Z_2 Z_3 + Z_3 Z_1}{Z_3}$$

$$Z_{23} = \frac{Z_1 Z_2 + Z_2 Z_3 + Z_3 Z_1}{Z_1}$$

$$Z_{13} = \frac{Z_1 Z_2 + Z_2 Z_3 + Z_3 Z_1}{Z_2}$$

Typical values for “ $z_k$ ” are 4-7% for small transformers (<5MVA) and 8-15% for larger transformers (these figures must be given by the transformer manufacturer in every single case as the values can differ within a wide range).

When it comes to the zero sequence impedance of the transformer, it's depending on the type of connection. These figures must be given by the manufacturer in every single case. The following figures can be a guideline:

**Dyn:**  $Z_0 = 0.8-1.0$  times  $Z_k$

**Yzn:**  $Z_0 = 0.1$  times  $Z_k$

**Yyn+d:**  $Z_0 = 2.5$  times  $Z_k$

**Yyn:**  $Z_0 = 5-10$  times  $Z_k$  for a three leg transformer without equalizing winding.

**Yyn:**  $Z_0 = 1000$  times  $Z_k$  for a five leg transformer or single phase transformers.

$Z_k$  is the short circuit impedance for three phase faults.

**Synchronous machines** are represented by the transient reactance as described earlier when the time aspect was discussed.

**Asynchronous machines** only contribute to the fault current, the motor operates as a generator, for about 100 ms after the fault occurrence. They are therefore neglected in short circuit calculations for protection relay applications.

---

## BALANCED FAULT CALCULATION

### **Impedance transformation**

To be able to make the calculations with Thevenin's theorem, all impedances must be transformed to the same voltage level with the following formula:

$$Z_1 = \left( \frac{V_1}{V_2} \right)^2 \times Z_2$$

where index 1, is the primary side and index 2, is the secondary side of the transformer.

### **Network reduction**

When all network parameters has been transformed into the same voltage level they can be calculated in the same way as series and parallel resistance. The total network impedance is then reduced to one impedance.

### **Short circuit calculation**

Now the phase voltage is connected to the impedances calculated above. The short circuit current is calculated with Ohm's law.

## **4.2 SHORT CIRCUIT CALCULATIONS WITH SHORT CIRCUIT POWER**

As an alternative to the impedance calculations described the short circuit power of the different objects can be used. It's then to be observed that:

- The result of short circuit powers in parallel is the series of the individual short circuit powers.
- The result of short circuit powers in series is the parallel connection of the individual short circuit powers.

The following examples shows the two methods used and normally a combination of both is used.

---

## **BALANCED FAULT CALCULATION**



# Fault Calculation

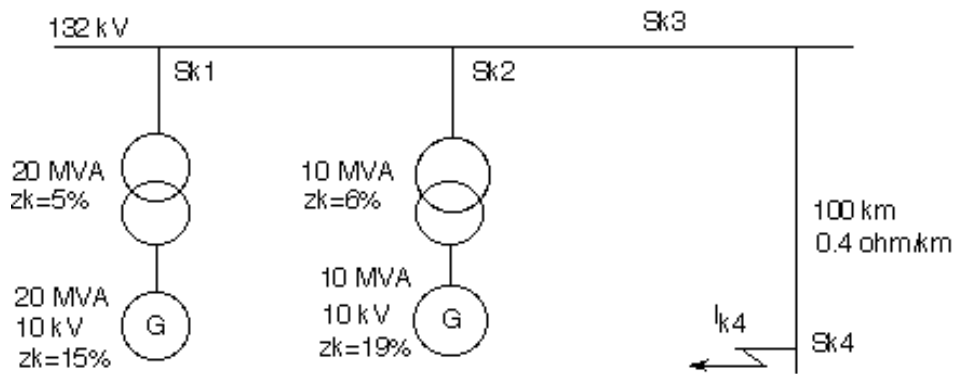

---

## BALANCED FAULT CALCULATION

Example 1. Calculate the fault current  $I_{K4}$  at a three phase fault.

$$X_{g1} = 0.15 \frac{10^2}{20} \left( \frac{132}{10} \right)^2 = 130.7 \Omega$$

$$X_{tr1} = 0.05 \frac{132^2}{20} = 43.6 \Omega$$

$$X_{g1} + X_{tr1} = 174.3 \Omega = X_{k1}$$

$$X_{g2} = 0.19 \frac{10^2}{10} \left( \frac{132}{10} \right)^2 = 331.1 \Omega$$

$$X_{tr2} = 0.06 \frac{132^2}{10} = 104.5 \Omega$$

$$X_{g2} + X_{tr2} = 435.6 \Omega = X_{k2}$$

The total short circuit impedance of the 132 kV busbar is:

$$X_{k3} = X_{g1} + X_{tr1} // X_{g2} + X_{tr2} = X_{k1} // X_{k2}$$

which gives:

$$X_{k3} = 124.5 \Omega$$

# Fault Calculation

We get the equivalent circuit:

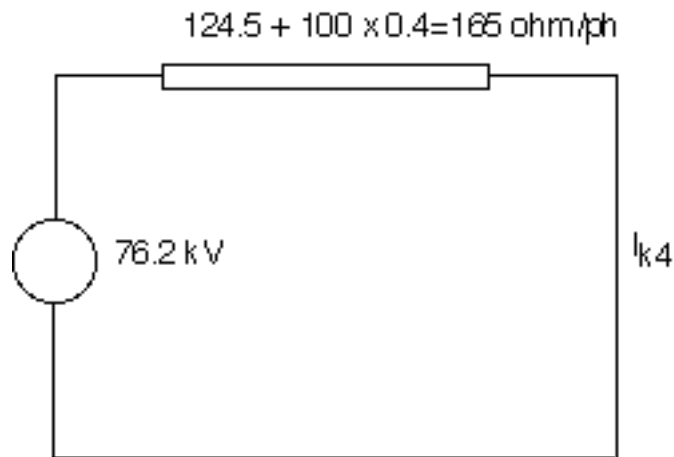

The following result is achieved:

$$I_{k4} = \frac{76.2}{124.5} = 0.46 \text{ kA}$$

**Calculation with short circuit power:**

$$S_{k1} = \frac{\frac{20}{0.15} \times \frac{20}{0.05}}{\frac{20}{0.15} + \frac{20}{0.05}} = 100 \text{ MVA}$$

$$S_{k2} = \frac{\frac{10}{0.06} \times \frac{10}{0.19}}{\frac{10}{0.06} + \frac{10}{0.19}} = 40 \text{ MVA}$$

“ $S_{k1} + S_{k2} = S_{k3}$ ” which gives: “ $S_{k3}$ ” = 140 MVA.

The equivalent short circuit power of the line is:

$$S_L = \frac{132^2}{40} = 435.6 \text{ MVA}$$

Now we get the total short circuit power up to the fault:

$$S_{k4} = \frac{(100 + 40) \times 435.6}{100 + 40 + 435.6} = 105.9 \text{ MVA}$$

This finally gives the fault current:

$$I_{k4} = \frac{105.9}{\sqrt{3} \times 132} = 0.46 \text{ kA}$$

## 5. UNBALANCED FAULT CALCULATION

Unbalanced faults means single phase faults or two phase faults with or without earth connection.

For a two phase fault without earth connection the fault current will be:

$$I_{2ph} = \frac{\sqrt{3}}{2} \times I_{3ph}$$

In reality there always is a resistance at the fault. The resistance at two phase faults consist mainly of the arc resistance. In some cases the resistance at the fault can be much higher than usual. For example when a wooden branch is stuck between the phases. To get a correct calculation of two phase faults symmetrical components are normally used.

For earth faults the earthing principle is the most important for the fault current. In an effectively earthed system, the fault current is of the same size as the three phase fault current. To make correct calculations of this current symmetrical components are used.

### 5.1 SYMMETRICAL COMPONENTS

The method of symmetrical components provides a practical technology for making fault calculations of unsymmetrical

---

#### UNBALANCED FAULT CALCULATION

# Fault Calculation

faults, both single- and two phase faults. The method was invented by Charles L Fortescue in 1913 and was developed further by others until its final form was presented in 1943.

The method is a mathematical tool which is used to describe and calculate the phenomena in a three phase system at unsymmetrical load or when an unsymmetrical fault occurs. For the three phase system three distinct sets of components are introduced for voltages and currents: positive, negative and zero sequence components.

**POSITIVE SEQUENCE SET** The positive sequence components consist of the balanced three phase currents and lines to neutral voltages supplied by the system generators. They are always equal in magnitude though the phases are displaced  $120^\circ$ . The positive system is rotating counterclockwise at the system frequency. To document the angle displacement it's convenient to introduce an unit phasor with an angle displacement of  $120^\circ$ , called "**a**". We get the following relations:

$$\mathbf{a} = 1/120^\circ = -0.5+j0.866$$

$$\mathbf{a}^2 = 1/240^\circ = -0.5-j0.866$$

$$\mathbf{a}^3 = 1/360^\circ = 1.0+j0$$

**CONVENTION IN THIS PAPER** The phase components are designated "**a**", "**b**", and "**c**". Positive sequence components are designated "1", negative "2" and zero sequence components "0". For example "**I<sub>a1</sub>**" means the positive sequence component of the phase current in phase "**a**".

Now the positive sequence set of symmetrical components can be designated:

$$I_{a1} = I_1$$

$$I_{b1} = \mathbf{a}^2 I_{a1} = \mathbf{a}^2 I_1 = I_1 / 240^\circ$$

$$I_{c1} = \mathbf{a} I_{a1} = \mathbf{a} I_1 = I_1 / 120^\circ$$

$$V_{a1} = V_1$$

$$V_{b1} = \mathbf{a}^2 V_{a1} = \mathbf{a}^2 V_1 = V_1 / 240^\circ$$

---

## UNBALANCED FAULT CALCULATION

$$V_{c1} = a^2 V_1 = a V_1 = V_1 / 120^\circ$$

**NEGATIVE SEQUENCE SET** This is also a balanced set of quantities with  $120^\circ$  phase displacement. The difference from the positive sequence components is that the system is rotating clockwise at power frequency.

The negative sequence set can be designated:

$$\begin{aligned} I_{a2} &= I_2 \\ I_{b2} &= a^2 I_1 = a I_1 = I_1 / 120^\circ \\ I_{c2} &= a I_1 = a^2 I_2 = I_2 / 240^\circ \\ V_{a2} &= V_2 \\ V_{b2} &= a^2 V_1 = a V_1 = V_1 / 120^\circ \\ V_{c2} &= a V_1 = a^2 V_2 = V_2 / 240^\circ \end{aligned}$$

**ZERO SEQUENCE SET** The zero sequence components are always equal in magnitude and phase in all phases.

We get the following equations:

$$\begin{aligned} I_{a0} &= I_{b0} = I_{c0} = I_0 \\ V_{a0} &= V_{b0} = V_{c0} = V_0 \end{aligned}$$

### Description of the system

All conditions in the network can be described using the above defined symmetrical components. Three groups of equations are used:

**BASIC EQUATIONS** These equations are valid during all conditions in the network and is a description of how the system of symmetrical components is built.

$$V_a = V_0 + V_1 + V_2 \quad (1)$$

$$V_b = V_0 + a^2 V_1 + a V_2 \quad (2)$$

$$V_c = V_0 + a V_1 + a^2 V_2 \quad (3)$$

$$I_a = I_0 + I_1 + I_2 \quad (4)$$

$$I_b = I_0 + a^2 I_1 + a I_2 \quad (5)$$

$$I_c = I_0 + a I_1 + a^2 I_2 \quad (6)$$

---

## UNBALANCED FAULT CALCULATION

# Fault Calculation

**GENERAL EQUATIONS** These equations are valid during all conditions in the network and give the conditions for the electromotoric forces in the network. The electromotoric forces only exist when the positive sequence components in a network are balanced before the fault occurs. The electromotoric forces only exist in the positive sequence system.

According to the superposition theorem the following statement is valid:

***A network can be replaced by a simple circuit, where the electromotoric force voltage equals the open circuit voltage of the network and the internal impedance equals the impedance of the network measured from the external side, if the voltage sources in the network are short circuited. The currents are defined positive out from the network.***

This gives the following equations:

$$E_1 = \bar{Y}^+ I_1 Z_1 \quad (7)$$

$$0 = \bar{Y}^- I_2 Z_2 \quad (8)$$

$$0 = \bar{Y}^0 I_0 Z_0 \quad (9)$$

Where “ $Z_1$ ” is the positive sequence impedance of the network, “ $Z_2$ ” is the negative sequence impedance and “ $Z_0$ ” is the zero sequence impedance of the network. The actual values of these network impedances are depending on the network and are used and reduced in the same way as when calculating symmetrical faults.

**SPECIAL EQUATIONS** These equations varies from fault to fault. They will be explained more in detail when the fault types are discussed later on, but can shortly be explained:

$$I_a = 0 \quad (10)$$

$$I_b + I_c = 0 \quad (11)$$

$$V_b - V_c = \bar{I} Z_{bc} \quad (12)$$

---

## UNBALANCED FAULT CALCULATION

## Impedance between two phases

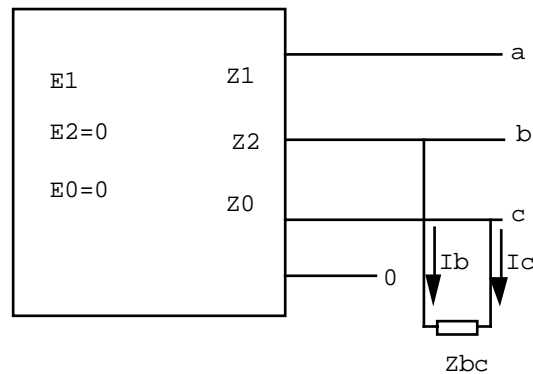

When the impedance “ $Z_{bc}$ ” is inserted, an unsymmetrical current is drawn from the network. The following equations are achieved according to the general, special and basic equations showed above.

According to equation (4):

$$I_0 + I_1 + I_2 = 0$$

$I_b = -I_c$  inserted in equation (5) and then taking (5) + (6) give:

$$2I_0 + (a+a^2)I_1 + (a^2+a)I_2 = 0$$

which means that:

$$I_0 = 0, \text{ since there is no earth-connection in the fault} \quad (13)$$

$$I_1 + I_2 = 0 \quad (14)$$

Equation (12) together with (2), (3) and (14) give:

$$(a^2 - a)(V_1 - V_2) = Z_{bc}(a^2 - a)I_1$$

$$V_1 - V_2 = Z_{bc}I_1 \quad (15)$$

Equation (7) and (8) together gives:

$$E_1 = V_1 - V_2 + I_1 Z_1 - I_2 Z_2 \quad (16)$$

Insert (14) and (15) into (16):

$$I_1 = \frac{E_1}{Z_1 + Z_2 + Z_{bc}} = -I_2 \quad (17)$$

---

## UNBALANCED FAULT CALCULATION



# Fault Calculation

Equations (13) to (17) gives for a two phase fault the following block diagram:

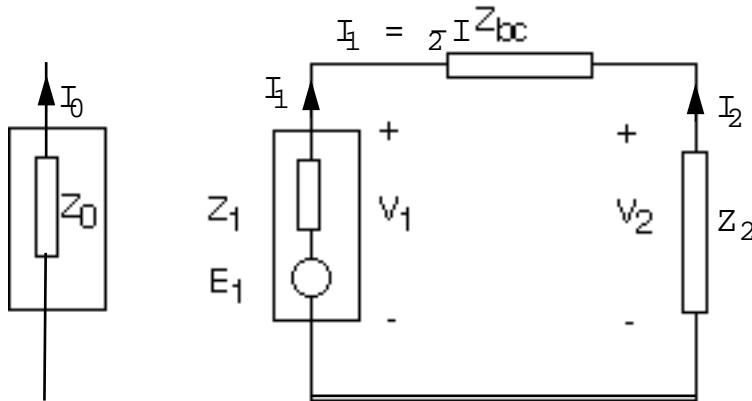

Insert 13, 17 into 7, 8 and 9 and you will get:

$$V_1 = E_1 \left( 1 - \frac{Z_1}{Z_1 + Z_2 + Z_{bc}} \right) \quad (18)$$

$$V_2 = E_1 \frac{Z_2}{Z_1 + Z_2 + Z_{bc}} \quad (19)$$

and:

$$V_0 = 0 \quad (20)$$

The unknown phase currents and voltages can be calculated by inserting 11,13 and 14 into 17 into the basic equations:

$$I_b = -I_c = a^2 - a \frac{E_1}{Z_1 + Z_2 + Z_{bc}} \quad (21)$$

Before the fault occurred there were only positive sequence voltage.

$$E_a = E$$

$$E_b = a^2 E$$

$$E_c = a E$$

---

## UNBALANCED FAULT CALCULATION

“ $E_a$ ”, “ $E_b$ ” and “ $E_c$ ” are the voltages, when the system is in a balanced condition.

This gives:

$$I_b = -I_c = \frac{E_b - E_c}{Z_1 + Z_2 + Z_{bc}} \quad (22)$$

and:

$$V_a = E_a \left( 1 - \frac{Z_1 - Z_2}{Z_1 + Z_2 + Z_{bc}} \right) \quad (23)$$

and:

$$V_b = E_b - \frac{E_b Z_1 - E_c Z_2}{Z_1 + Z_2 + Z_{bc}} \quad (24)$$

$$V_c = E_c - \frac{E_c Z_1 - E_b Z_2}{Z_1 + Z_2 + Z_{bc}} \quad (25)$$

In reality, we have “ $Z_1 = Z_2 = Z$ ”. The following network is achieved:

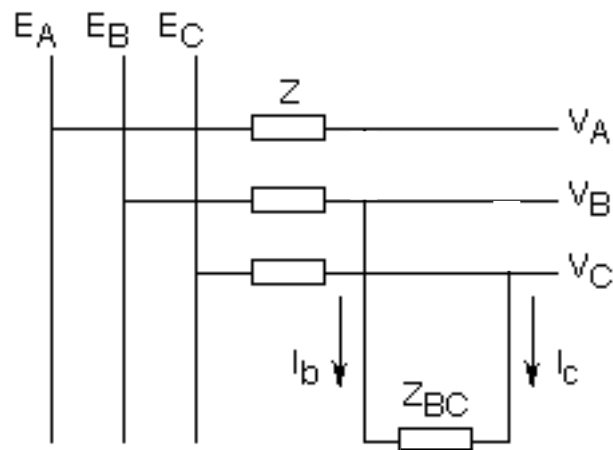

The following equations are achieved:

$$I_b = -I_c = \frac{E_b - E_c}{2Z + Z_{bc}} \quad (26)$$

$$V_a = E_a \quad (27)$$

---

## UNBALANCED FAULT CALCULATION

# Fault Calculation

$$V_b = E - ZI \quad (28)$$

$$V_c = E - ZI \quad (29)$$

For a two phase fault without fault resistance " $Z_{bc}$ " is set to 0.

## Impedance between phase and earth

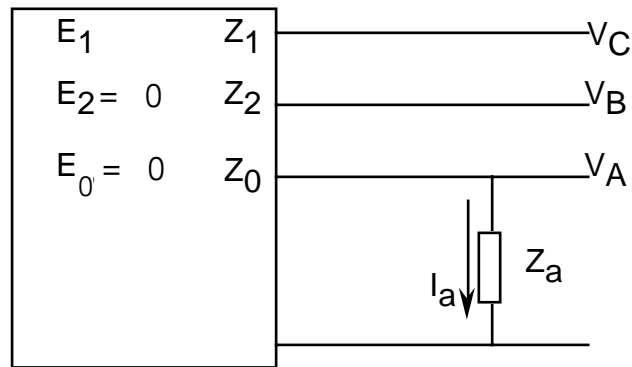

The general and the basic equations will still be the same as in "Impedance between two phases" but the following special equations are achieved:

*The special equations:*

$$I_b = 0 \quad (30)$$

$$I_c = 0 \quad (31)$$

$$V_a = Z_a I_a \quad (32)$$

---

## UNBALANCED FAULT CALCULATION

Transformation of the equations 30, 31, 5, 6, as in "Impedance between two phases" gives the following result:

$$I_0 = I_1 = I_2 \quad (33)$$

$$I_1 = I_2 = I_0 = \frac{E_1}{3Z_a + Z_0 + Z_1 + Z_2} \quad (34)$$

$$V_1 = E_1 - \frac{E_1 Z_1}{3Z_a + Z_0 + Z_1 + Z_2} \quad (35)$$

$$V_2 = \frac{E_1 Z_2}{3Z_a + Z_0 + Z_1 + Z_2} \quad (36)$$

$$V_0 = \frac{E_1 Z_0}{3Z_a + Z_0 + Z_1 + Z_2} \quad (37)$$

This gives the following figure:

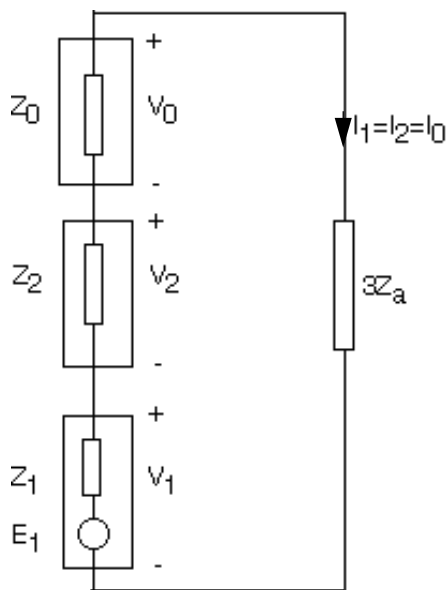

$$I_a = \frac{3E_a}{2Z + Z_0 + 3Z_a} \quad (38)$$

$$I_b = I_c = 0 \quad (39)$$

---

## UNBALANCED FAULT CALCULATION

# Fault Calculation

$$V_a = E_a \left( 1 - \frac{2Z + Z_0}{2Z + Z_0 + 3Z_a} \right) \quad (40)$$

$$V_b = E_b - E_a \frac{Z_0 - Z}{2Z + Z_0 + 3Z_a} \quad (41)$$

$$V_c = E_c - E_a \frac{Z_0 - Z}{2Z + Z_0 + 3Z_a} \quad (42)$$

This simple network is achieved:

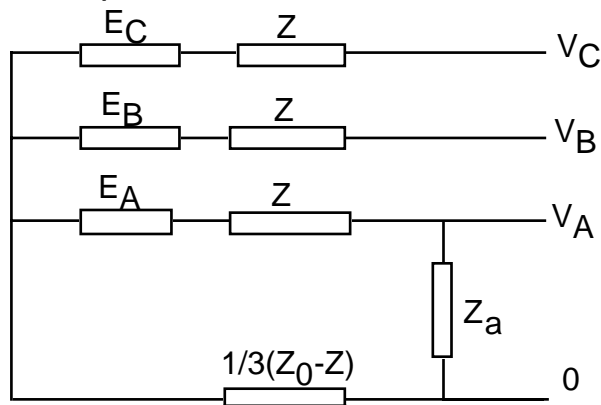

## Example 1

Generator:  $X_g = 24.2 \Omega/\text{ph}$ , ( $X_1 = X_2$ )

Transformers:  $X_{k1} = 12.1 \Omega/\text{ph}$ ,  $X_{k2} = 10 \Omega/\text{ph}$

(Zero and positive sequence impedances equal).

Network:  $X_n = 8.3 \Omega/\text{ph}$

Line:  $X_1 = 40 \Omega/\text{ph}$ ,  $X_0 = 120 \Omega/\text{ph}$

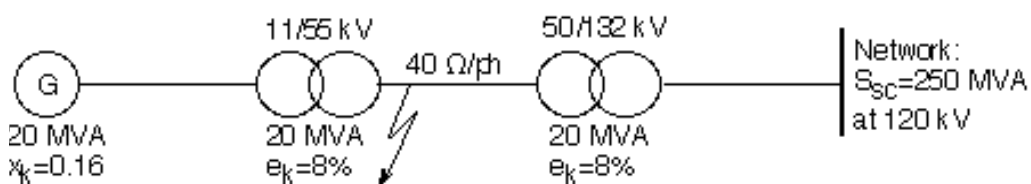

## UNBALANCED FAULT CALCULATION

Calculate the fault current for:

- Two phase fault with zero fault resistance.
- Single phase solid earth fault.

a) Two phase short circuit

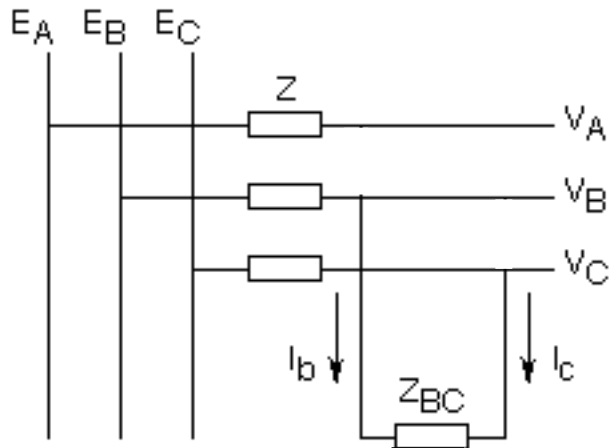

This scheme is valid when “ $Z_1=Z_2=Z$ ”.

In this case “ $Z_{bc}$ ” is set to 0.

The value of “ $Z$ ” is calculated:

$$Z = \frac{(X_g + X_{k1})(X_L + X_{k2} + X_n)}{X_g + X_{k1} + X_L + X_{k2} + X_n}$$

Then “ $Z$ ” = 22.4  $\Omega$ /ph and “ $I_b$ ” = 1.23 kA/ph

b) Single phase solid earth fault

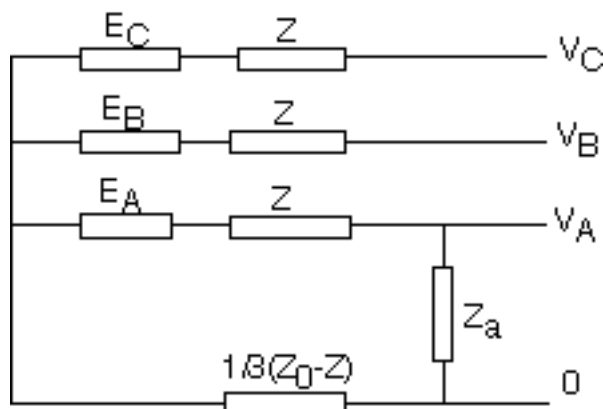

This scheme is also valid when “ $Z_1=Z_2=Z$ ” and “ $Z$ ” = 22.4  $\Omega$ /ph

---

## UNBALANCED FAULT CALCULATION

# Fault Calculation

$$I_a = \frac{3E_a}{2Z + Z_0 + 3Z_a}$$

$$X_{0tot} = \frac{X_{k1}(X_{0L} + X_{k2})}{X_{k1} + X_{0L} + X_{k2}}$$

This gives “ $X_{0tot}$ ” = 11.1  $\Omega/ph$  and

$$I_a = \frac{55 \times 3}{\sqrt{3}(11.1 + 2 \times 22.4)} = 1.71 \text{ kA}$$

It should be noted that the current at single phase fault is higher than the fault current at three phase fault.

## Example 2:

Transformer: 20MVA, 16/77 kV,  $x_k = 8\%$ , Yd11

Generator: 20MVA, 16 kV,  $x(\text{transient}) = 25\%$ ,  $X_2 = X_1$

Line:  $x_1 = 84 \Omega/ph$ ,  $X_0 = 300 \Omega/ph$

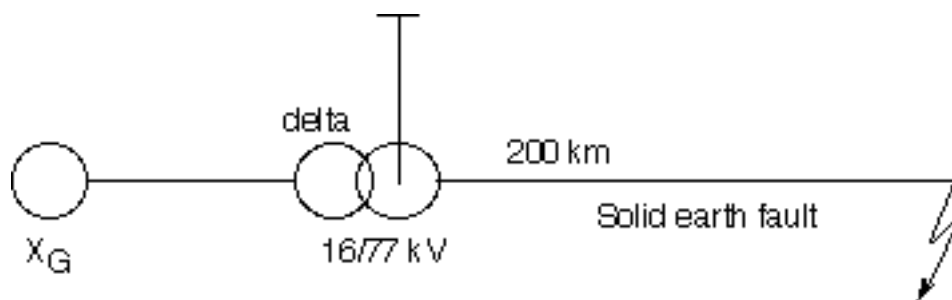

The line is considered unloaded before the fault and all resistance and capacitance is neglected. The voltage at the fault position is 75 kV before the fault.

Calculate the fault current through the earth connection of the transformer, the phase currents on both sides of the transformer and the voltages (to earth) in the HV terminals of the transformer.

---

## UNBALANCED FAULT CALCULATION

Calculation of the 77 kV impedances.

Generator:

$$X_1 = X_2 = 0.25 \times \frac{16^2}{20} \times \left(\frac{77}{16}\right)^2 = 74 \Omega/\text{ph}$$

Transformer:

$$X_1 = X_2 = 0.08 \times \frac{77^2}{20} = 23.7 \Omega/\text{ph}$$

Line:

$$X_1 = X_2 = 8 \Omega/\text{ph}, X_0 = 300 \Omega/\text{ph}$$

The following block diagram is achieved:

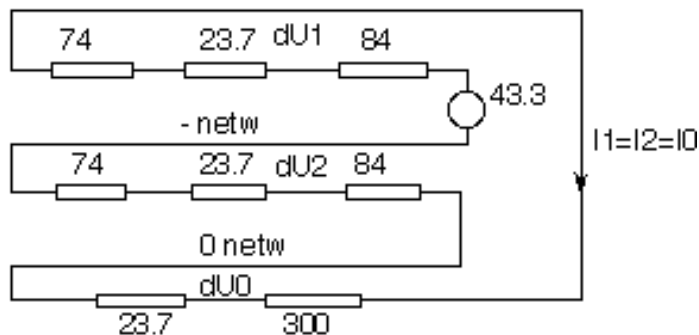

$$X_1 = X_2 = 181.7 \Omega/\text{ph}$$

$$X_0 = 323.7 \Omega/\text{ph}$$

$$I_1 = I_2 = I_0 = \frac{75}{\sqrt{3}(2 \times 181.7 + 323.7)} = 0.063 \text{ kA/ph}$$

The current through the earth connection of the transformer.

$$I_g = 3I_0 = 0.189 \text{ kA}$$

The component voltages at the HV side:

$$U_1 = E + dU_1 = 43.3 - (j97.7)(-j0.063) = 37.15 \text{ kV}$$

$$U_2 = dU_2 = -j97.7(-j0.063) = -6.15 \text{ kV}$$

$$U_0 = dU_0 = -j23.7(-j0.063) = -1.49 \text{ kV}$$

Phase voltages:

---

## UNBALANCED FAULT CALCULATION



$$U_a = U_0 + U_1 + U_2 = 29.5/0^\circ \text{ kV}$$

$$U_b = U_0 + a^2 U_1 + a U_2 = 41.3/-114.4^\circ \text{ kV}$$

$$U_c = U_0 + a U_1 + a^2 U_2 = 41.3/114.4^\circ \text{ kV}$$

Phase currents:

$$I_a = I_0 + I_1 + I_2 = 3 \times 0.063 = 0.19 \text{ kA}$$

$$I_b = I_0 + a^2 I_1 + a I_2 = 0.063(1 + a) = 0 \text{ kA}$$

$$I_c = I_0 + a I_1 + a^2 I_2 = 0.063(1 + a) = 0 \text{ kA}$$

Phase currents on the LV side:

Connection:

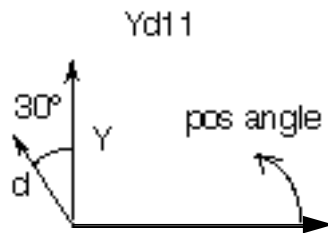

Figure 2. The positive sequence current is turned  $+30^\circ$ , while the negative sequence current is turned  $-30^\circ$ .

At the 16 kV side there is no zero sequence current as the transformer is Yd connected " $I_0$ "=0.

The phase currents at the 16 kV side:

$$I_a = \frac{77}{16}(0 + 0.063e^{j30^\circ} + 0.063e^{-j30^\circ}) =$$

$$= \frac{77}{16}\sqrt{3} \times 0.063 = 0.52 \text{ kA}$$

$$I_b = \frac{77}{16}(0 + 0.063e^{j30^\circ} a^2 + 0.063e^{-j30^\circ} a) =$$

$$= \frac{77}{16}(0.063e^{j30^\circ} e^{-j120^\circ} + 0.063e^{-j30^\circ} e^{j120^\circ}) = 0 \text{ kA}$$

---

## UNBALANCED FAULT CALCULATION

$$\begin{aligned}
I_c &= \frac{77}{16}(0 + 0.063e^{j30^\circ} a + 0.063e^{-j30^\circ} a^2) = \\
&= \frac{77}{16}(0.063e^{j30^\circ} e^{j120^\circ} + 0.063e^{-j30^\circ} e^{-j120^\circ}) \\
&= \frac{77}{16}\sqrt{3} \times 0,063 = 0.52 \text{ kA}
\end{aligned}$$

---

## UNBALANCED FAULT CALCULATION

# System Earthing

## 1. WHAT IS SYSTEM EARTHING

The term “earthing” consists of several functions which only have “utilizing the earth” in common. Before describing the system earthing, it can be of interest to know a bit about the different types of earthing.

*Protective earthing* is applicable mainly in electronic equipment to prevent damage or errors at the components. Example of protective earthing is when a screened cable is earthed, or when an incoming signal conductor is connected to earth through a capacitor or a filter.

Protective earthing can be described as a way of protecting man from dangerous voltages. Example of protective earthing is, when the casing of e.g. a washing machine is connected to earth (green/yellow conductor) or when a row of switchgear cubicles are connected to an earth conductor, which connects the cover of the cubicle to earth.

Lightning protection can also be a part of system earthing.

*System earthing* concern the kind of deliberate measures that connects a normally live system to earth. It is normally the zero point of the system that is connected to earth but other solutions can occur.

Of course, all types of systems can be earthed, and the terminology “system earthing”, can thus be used. Systems like electronic systems and battery systems, measuring transformer circuits etc., are often earthed. In the following text we will only consider system earthing of alternating current systems for power distribution and transmission, with a voltage over 150 V.

If a point in a system is earthed the whole system will be earthed as far as the galvanic connection goes. A system earthing on the contrary does not affect the parts of the network that are connect-

---

### WHAT IS SYSTEM EARTHING

ed magnetically to the earthed part of the network, for example through transformers. See figure 1.

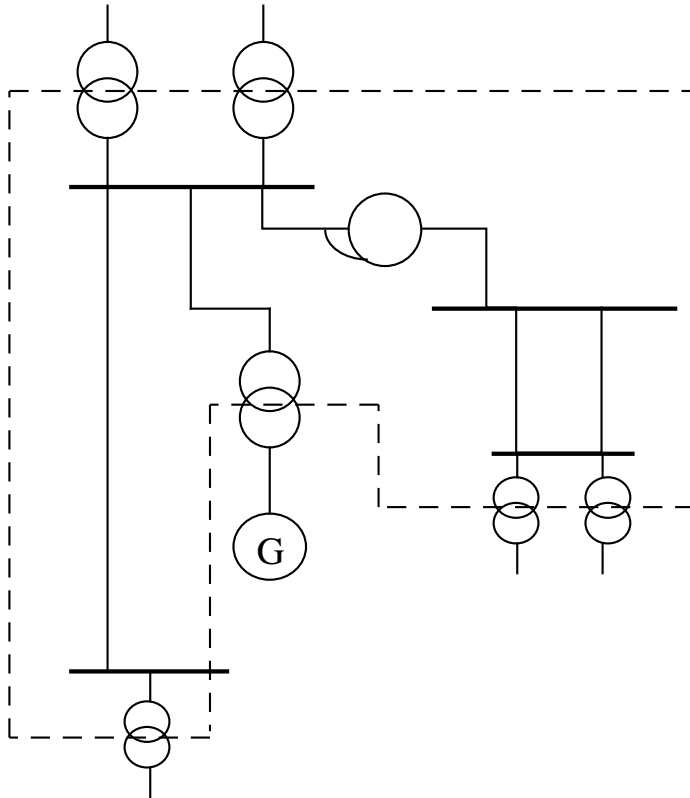

Figure 1. The earthing of a system is effective for all galvanic connected parts.

## 2. WHY USE SYSTEM EARTHING

The main reason for connecting the network to an earth potential, is of course that both human beings and equipment will be protected. These are only two reasons for system earthing but many other requirements on operation reliability have to be fulfilled as well.

Some of the reasons to use system earthing are described in the following text.

### 2.1 FIX THE NETWORK TO EARTH POTENTIAL

All alternating current networks are in one way or another coupled to earth through leakage capacitances. The capacitances can be so small that the network at some occasions can reach a dangerously high potential.

---

#### WHY USE SYSTEM EARTHING

# System Earthing

If a connection between the conductors in two networks with different voltage occurs, the network with the lowest voltage would get a dangerously increased voltage to earth. This can be prevented by a suitable earthing of the network with the lowest voltage.

Even if there is no direct connection a dangerous voltage can occur due to the capacitive coupling between the two networks.

## 2.2 REDUCE THE FAULT CURRENT AT EARTH FAULT.

In an unearthed network a capacitive current will appear when an earth fault occurs. This derives basically from the leakage capacitance in cables and overhead lines but also generators, motors and transformers contributes. Depending on the voltage level and the distribution of the network this current can reach values from a few, up to hundreds of Amperes in big cable networks. The cables will give the highest capacitive current.

A formula for the capacitive current  $I_C$  of cables is normally stated as  $I_C = U_H/10 \times 3$  A/km, where  $U_H$  is the line voltage.

If the capacitance of the network is compensated with a reactor connected to the neutral point, the current through the fault point can be drastically reduced, See figure 2. This is advantages since the damage caused by the fault current through the fault location is limited.

---

### WHY USE SYSTEM EARTHING

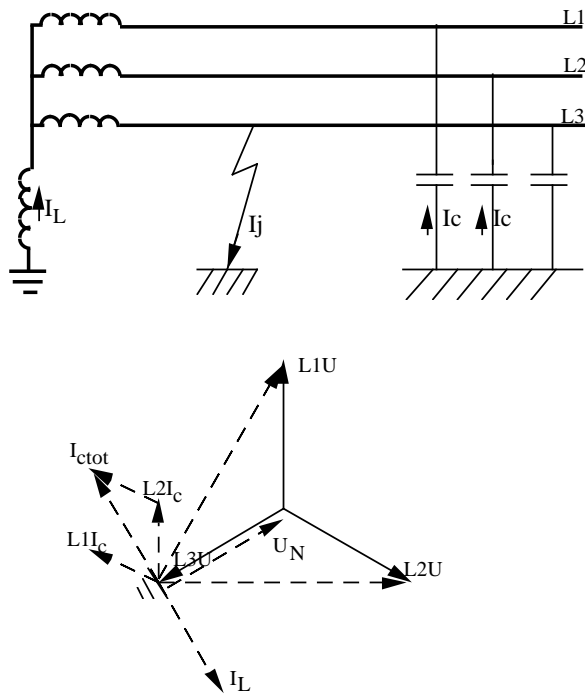

Figure 2. Reduction of earth fault current with a neutral-point impedance. Resulting earth fault current  $I_j$  is very small if  $I_L = I_{CTot}$

## 2.3 REDUCE OVERVOLTAGES

The overvoltages that can be reduced through system earthing are those who depend on transient earth faults, increased neutral-point voltage and transients due to switching or lightning.

### Transient earth faults

At occurring earth faults, especially in systems with small earth fault current, the conditions are such that the arc will be extinguished at the zero passage of the current. Afterwards it will be re-ignited when the voltage increases over the fault point again. This phenomenon is in USA, called “arcing grounds”.

If the current and the voltage at the fault point not are zero simultaneously the transient fault can throughout repeated extinctions and reignitions create a high overvoltage in the whole network. The overvoltage will be particularly high if the system is com-

---

## WHY USE SYSTEM EARTHING

# System Earthing

pletely unearthed and the earth fault current is only dependent of the leakage capacitance of the system, this is shown in Figure 3.

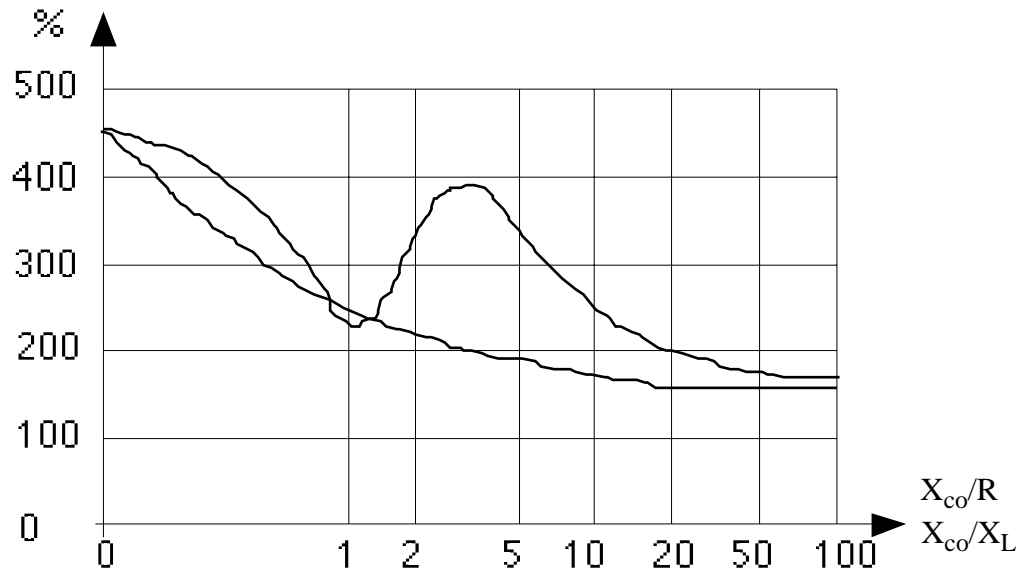

$X_{c0}$  is the total network reactance to earth  $1/\omega C$ .

$R_0$  is the neutral resistor resistance at resistance earthing

$X_L$  is the neutral reactor reactance  $\omega C$

Figure 3. The influence of earthing, in the maximum overvoltage, due to transient earth faults. The transient overvoltage in the figure, is written in percent of the phase voltage top value. The upper curve shows the overvoltage for a neutral reactor earthing.

“ $x_c$ ” is the leakage capacitive reactance to earth which is dependent of the total capacitance ( $1/\omega C$ ) of the network and “ $R$ ” is the resistance of the neutral resistor.

The figure above shows that an earthing should be performed in such a way that the earthing resistance is less or equal to the capacitive reactance to earth. If the system is earthed through a reactor its reactance should be almost equal to, or a lot less, than the total capacitive reactance to earth.

The figure shows the overvoltages that can occur during unfavorable circumstances but normally overvoltages are less. As can be seen the overvoltages in unearthed systems can be of the size, or higher than, the test voltage for new generators and motors. The risk of damaging these apparatuses will therefore be very high. Surge arresters won't give a reliable protection, since they will be destroyed at repeated overvoltages. A system which

---

## WHY USE SYSTEM EARTHING

contains generators or motors should therefore always be earthed in some way.

### **Increased neutral-point voltage**

In case of an earth fault in one phase in an unearthed network a phase-ground voltage will appear in the neutral-point and the other two phases will thus have their phase-phase voltage to earth. By using an effective earthing (see section 3.2) the voltage can be reduced to 80% of the phase-phase voltage. It's then possible to choose apparatuses with lower insulating level which means considerable cost reducing at high voltage networks. A transformer with a direct earthed neutral-point can furthermore be equipped with graded insulation. This means that the insulation level is lower close to the neutral-point than at the line terminals which give considerable savings for big power transformers.

### **Coupling and lightning overvoltages**

Operating of switching apparatuses can create overvoltages which usually are higher than three times the nominal voltage but of short duration. The overvoltages are created through transient oscillation in the capacitance and the inductance of the circuit.

Neutral point earthing will probably not reduce the overvoltages created by switching waves or lightning. They can though distribute the voltage between the phases and reduce the possibility of a high voltage stress on the insulation between one phase and earth.

## **2.4 SIMPLIFY LOCATION OF EARTH FAULTS**

In an unearthed network it's often difficult to detect and clear an earth fault. Through a suitable earthing it's possible to create an earth fault current that can be measured and also form a base for the locating of the earth faults.

---

### **WHY USE SYSTEM EARTHING**



# System Earthing

## 2.5 AVOID FERRO-RESONANCE

Voltage transformers connected to an unearthed network can under particular circumstances create abnormal neutral-point voltages. The voltage transformer can then be regarded as a non-linear inductance, which goes into self-oscillation with the capacitance of the network. This phenomenon is called “ferro-resonance”.

The abnormal neutral point voltage can damage the voltage transformers and create unwanted earth fault indications. If the network is earthed the phenomenon will not appear. In an unearthed network the oscillation can be prevented by connecting a resistor either to the “delta” winding in a three phase voltage transformer or to a zero-point voltage transformer. Note that such a resistor gives the same result as a resistor with a very high resistance connected directly between the zero-point and earth (See figure 4).

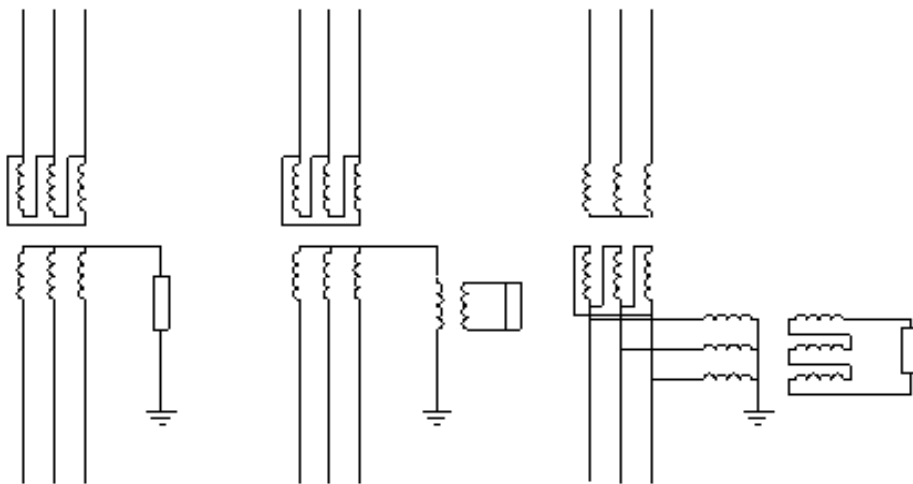

Figure 4. Three equal methods to prevent ferro resonance.

---

### WHY USE SYSTEM EARTHING

### 3. DIFFERENT TYPES OF SYSTEM EARTHING

In Swedish Standards (following IEC) the following earthing alternatives are given:

- a) Systems with an isolated neutral-point
- b) Coil earthed systems.
- c) Earthed system:
  - Effectively earthed system
  - Not effectively earthed system.

In American literature, "Electrical power distribution for Industrial Plants" (ANSI/IEEE 141 1986), the following alternatives are mentioned:

- a) Solidly earthed (without deliberate earthing impedance)
- b) Reactance earthed
- c) Resistance earthed by low- or high resistance.
- d) Unearthed

With these alternatives as a base it's possible to distinguish the types of earthing that are explained in the following sections:

#### 3.1 DIRECT EARTHING

Direct earthing means that the neutral-point of the network is earthed in at least one point without deliberately inserting any impedance. Observe that this not quantifies how effective the earthing is since the neutral point impedance still can be high. This can happen if i.e. the neutral-point in a transformer, that is small compared to the short circuit effective output of the network, is earthed. It can also happen if the earth resistance is high.

Direct earthing describes how the earthing is done not the result achieved. However, normally it's understood that the direct earthed system should be effectively earthed.

# System Earthing

## 3.2 EFFECTIVE EARTHING

An effectively earthed network follows the requirements given in ANSI and SS (Cenelec). A system, or a part of a system, is considered effectively earthed, when the following statements are valid in all points of the system:

ANSI & SS (Cenelec) gives " $X_0 \leq 3X_1$ " and " $R_0 \leq X_1$ ", where " $X_0$ " is the zero sequence reactance, " $R_0$ " is zero sequence resistance and " $X_1$ " is the positive sequence reactance.

The requirements leads to a maximum voltage of 80% of nominal line voltage between a phase and earth, called the earthing factor. Therefore lower insulation requirements can be accepted and surge arresters with lower extinction voltages can be used.

## 3.3 REACTANCE EARTHING

The concept reactance earthing occurs basically in american literature and relates to earthings where " $X_0 \leq 10X_1$ ". The factor "10" is required to drastically reduce the overvoltages due to transient earth faults. Reactance earthing is used mainly when a direct earthing of a generator's neutral point is not desired.

## 3.4 LOW RESISTANCE EARTHING

Resistance earthing is an earthing where " $R_0 \leq 2X_0$ " but " $R_0$ ", still is so small that a big earth fault current is obtained. The resistance earthing is normally done in such a way that, when a fully developed earth fault occurs, an earth fault current between 200 and 2000 A is achieved. The advantage with this way of earthing is that normal relays can be used for detection of earth faults.

Resistance earthing is one out of two methods recommended by the english standard CP 1013:1965. The proposed current value

---

### DIFFERENT TYPES OF SYSTEM EARTHING

is 300 A. The other method is earthing through a voltage transformer i. e. a unearthed networks.

---

## DIFFERENT TYPES OF SYSTEM EARTHING

# System Earthing

## 3.5 HIGH RESISTIVE EARTHING

High resistive earthing concerns the cases where the factor “ $3R_0 \leq X_{c0}$ ”, where “ $X_{c0}$ ” is the total capacitance of the network per phase against earth, is obtained by using the biggest possible resistance  $R_0$  to earth.

If the capacitive current in a network at a fully developed earth fault is less than 30 A it's possible, up to voltages of 25 kV, to provide the system with a neutral-point resistance for currents of at least the same size as the capacitive current of the network.

At transient earth faults the voltage in the network stays within reasonable limits (see figure 3) and the current to earth increases with only 50% compared to the unearthed system. The neutral-point resistance can, if desired, relatively easy be installed to withstand the phase voltage. Therefore it's not necessary to have a tripping earth fault relay at locations where it would create major disadvantages for the operation. This can e. g. be the case for industrial plants where tripping can cause a big disturbance for the service.

When high resistive earthing is mentioned, basically in American literature, an earthing through an one-phase transformer loaded with a resistor secondary is intended. This is electrically equivalent to a resistor directly connected between the neutral-point and earth. See figure 5.

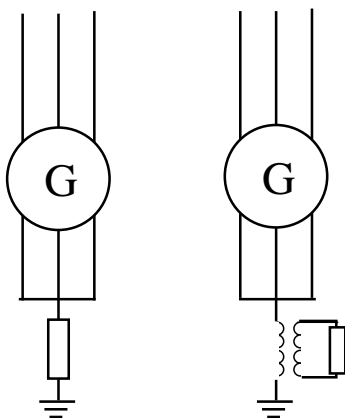

Figure 5. Two equivalent methods for high resistance earthing.

---

## DIFFERENT TYPES OF SYSTEM EARTHING

### 3.6 RESONANCE EARTHING (EARTHING WITH PE-TERSÉN-COIL)

For resonance earthing an inductance calibrated to the capacitance of the network at rated frequency is chosen. This leads to a small resulting operating frequency earth fault current and it is only caused by the current due to insulation leakage and corona effect. An arc in the fault point can therefore easily be extinguished since current and voltage are in phase and the current is small. Observe that a strike through a solid material like paper, PVC, cambric or rubber isn't self-healing why they don't benefit from the resonance earthing.

The resonance coil should be calibrated to the network for all connection alternatives. Therefore the setting must be changed every time parts of the network are connected or disconnected. There however exists equipment, e. g. in Sweden, Germany and Austria, that will do this automatically.

At a resonance earthing it is often difficult to obtain selective earth fault relays. Therefore the resonance coil is connected in parallel with a suitable resistor giving a current of 5 to 50 A at full zero-point voltage, i. e. a solid fault. The resistor should be equipped with a breaker for connecting and disconnecting at earth faults. The breaker should be used for the In-Out automatic and for the thermal release of the resistor, if the fault is not automatically cleared by the protection relays, as these normally are not designed to allow continues connecting.

The theories about resonance earthing are very old and were developed at the time when only overhead transmission lines existed. In cable networks, high harmonic currents are generated through the fault point. Even if the network is exactly calibrated it's possible that currents up to several hundred amperes appears. This of course leads to difficulties for an earth fault to self extinguish.

---

#### DIFFERENT TYPES OF SYSTEM EARTHING

# System Earthing

Resonance earthing can also be a way to fulfil the requirements concerning the standards for maximum voltage in earthed parts.

Through resonance earthing a smaller earth leakage current is obtained and consequently a higher earthing grid resistance can be accepted.

In an unearthed or voltage transformer earthed system the risks for overvoltages at transient faults are not considered.

Generally it is recommendable to avoid unearthed systems. In the British standards this is explicitly stated.

---

## DIFFERENT TYPES OF SYSTEM EARTHING

## 4. TO OBTAIN A NEUTRAL-POINT

In a three phase network the neutral-point often is available in a “Y” connected transformer or in a generator neutral. This should then be utilized at system earthing.

If the transformer is connected “Y0/D” or “Y-0/Y-0” with delta equalizing winding, the “Y-winding” can be utilized even for direct earthing. An “Y/Y” connected transformer without such an equalizing winding shall not be directly earthed but can under some circumstances be utilized for high resistance or resonance earthing.

### 4.1 Y0/Y-CONNECTED TRANSFORMER

If one side of a “Y/Y” connected transformer is earthed, theoretically there wouldn't flow any current through the earth connection since it is impossible to create a magnetic balance in the windings for this kind of currents. However, the flow is closed through leakage fields from yoke to yoke through insulation material and plates. This can create a local heating that will damage the transformer.

If the transformer has a magnetic return conductor as e. g. a five leg transformer or three one phase units the earth current leads to a flow in the return conductor.

The zero sequence impedance for an “Y0/Y” transformer is always high but varies, depending on the design, from 3 to 40 times the short circuit current impedance.

If you are aware of the high zero sequence impedance and if the transformer construction accepts the heating problems a “Y0/Y” connected direct earthed transformer limiting the earth fault current to about the transformers rated current can be utilized in the power system.

### 4.2 Z/0-CONNECTED EARTHING TRANSFORMER

In the “Z/0” connected transformer, see figure 7, a magnetic balance for zero sequence current leading to a low zero sequence

---

TO OBTAIN A NEUTRAL-POINT



# System Earthing

impedance is created. The neutral point of the transformer can either be connected directly to earth or through another neutral point apparatus such as a resistor or reactor. In the first case the thermal consequences must be cleared in advance as the “Z/0” transformer often has limited thermal capability. The earthing “Z/0” transformer is thus often specified for 10 or 30 sec thermal rating.

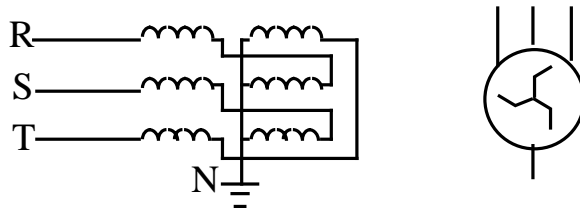

Figure 6. Z/0-connected earthing transformer.

---

TO OBTAIN A NEUTRAL-POINT

## 5. DISTRIBUTION OF EARTH FAULT CURRENT

In calculating earth fault currents it's advantageous, but not necessary, to use symmetrical components to check the flow of the earth fault currents.

A very simple way of checking, where only peripherally the theory of symmetrical components is used, could be utilized. According to this theory a current " $3I_0$ " (three times the zero sequence current), flows through the neutral-point. This can be used in letting the fault be represented by three "current arrows" and then examine how these can be distributed in the system maintaining the magnetic balance. Possible positive and negative sequence currents are then not considered. Some examples of these calculations are shown in the text that follows but first an explanation of the "zero sequence impedance".

### 5.1 ZERO SEQUENCE IMPEDANCE

In the previous discussion the name "zero sequence impedance" has been used at several occasions. The easiest way to understand this term is to indicate how to measure it in practice.

The measurement of zero sequence impedance is done by short circuiting the three phases with preserved earthing of the network. Each phase has then a zero sequence impedance which is three times the impedance measured between the three phases and earth.

### 5.2 CURRENT DISTRIBUTION AT AN EARTH FAULT WITH A Z/O EARTHING TRANSFORMER.

Whether the network has been earthed in the neutral-point, or with a Z/O connected transformer on the generator's line terminals, the result of the earthing will be the same. This is illustrated in figures 8 and 9.

# System Earthing

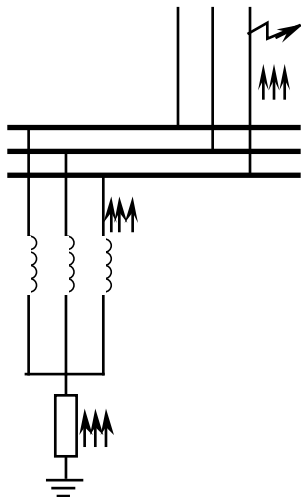

Figure 7.

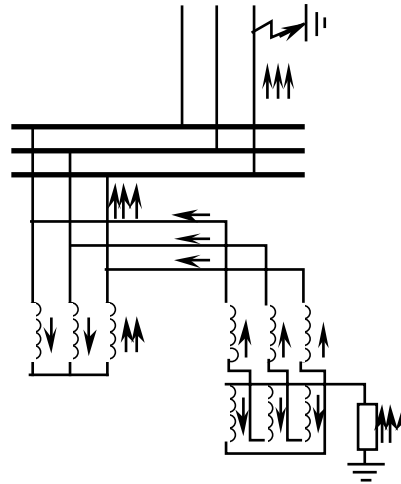

Figure 8.

*Figure 7. The earth fault current distribution, with a resistance in the generator neutral-point.*

*Figure 8. The earth fault current distribution, with a neutral-point resistance, connected to a Z/O-connected earthing transformer.*

The figures above shows that the earthings are equal from the networks point of view.

In the first case a zero sequence current goes through the generator.

In the second case the current does not contain any zero sequence component since the sum of the currents in the three phases is zero.

The generator current contains only one positive and one negative sequence component.

## 5.3 CURRENT DISTRIBUTION AT AN EARTH FAULT IN A TRANSMISSION NETWORK.

To show that the earth fault current not necessarily need to come from the same direction as the power an earth fault, in a directly

---

### DISTRIBUTION OF EARTH FAULT CURRENT

earthed transmission network, where the receiving transformer is earthed but unloaded is chosen, see figure 10.

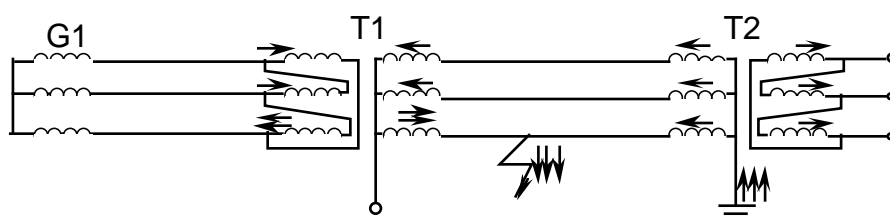

Figure 9. Current distribution in a transmission network.

It is possible to see in the figure, that neither the generator nor the transformer “T1” has a zero sequence current since the sum of the currents in all phases is zero. It is however easy to realize that a negative sequence current exist. An earth current protection measuring negative sequence current at “T2:s” HV line terminal, would thus operate despite the fact that “T2” is unloaded.

---

## DISTRIBUTION OF EARTH FAULT CURRENT

# System Earthing

## 6. TO CHOOSE SYSTEM'S EARTHING POINT

Normally in directly earthed and effectively earthed systems every available neutral point is earthed. Deviations from this occurs when the transformers neutral points are left unearthed. This is done to limit the maximum earth fault current which can arise to reasonable values. In these cases the neutral-point is equipped with surge arresters. This is only acceptable if the network at all operation modes still can be considered as effectively earthed ( $X_0 \leq 3X_1$ ).

For the other earthing methods it is somewhat more complicated. For example the wish to keep the earth fault current more or less constant, at the same time as the network always must be earthed independently of the operation mode, gives contradictions and difficult choices.

### 6.1 INDIVIDUAL EARTHING IN EVERY NEUTRAL POINT OF THE POWER SOURCES

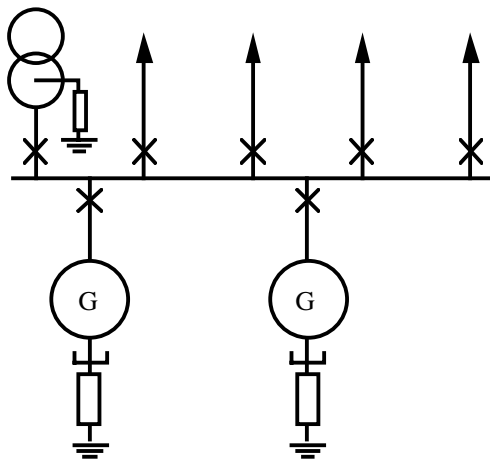

Figure 10. Earthing individual neutral-point with impedances.

When there only are a few generators or transformers in a station, individual neutral-point impedances are often used. Hereby the neutral-point connection is fixed without intervening connec-

---

### TO CHOOSE SYSTEM'S EARTHING POINT

tion devices. When just two power sources are used individual neutral-point impedances are preferred to a common earthing impedance. When several power sources are used the earth fault current is increased every time a power source is connected and can reach unwanted values. At resistance earthing every resistor must be dimensioned for a current high enough to satisfy the operation of the relay equipment, when this is working alone. Consequently the total earth fault current at several aggregates, becomes several times the value required for a satisfying relay function. A disconnecter is thus often provided to enable disconnection of resistors when system is in parallel service condition.

The method with individual earthing is normally utilized at resistance and reactance earthing, but it can also be utilized at high resistive earthing. For resonance earthing the method is very unsuitable.

Together with generators or motors, multiple earthing can be unsuitable due to the danger of circulating third harmonic currents.

## **6.2 COMMON EARTHING THROUGH A NEUTRAL BUSBAR.**

When there are more than two generators, or transformers, in a station it can be preferable to use just one neutral-point apparatus. The neutral-point of every power source is then connected through a coupling device, breaker or disconnecter, to a common neutral busbar which is earthed through a resistor or a reactor. This arrangement keeps the earth fault current at optimal size, since it never has to be higher than what is needed to avoid overvoltages or to give a safe relay protection operation. There is always the same earth fault current independent of the service condition.

Two different connections with neutral-point busbars are shown in figures 12 and 13.

---

### TO CHOOSE SYSTEM'S EARTHING POINT

# System Earthing

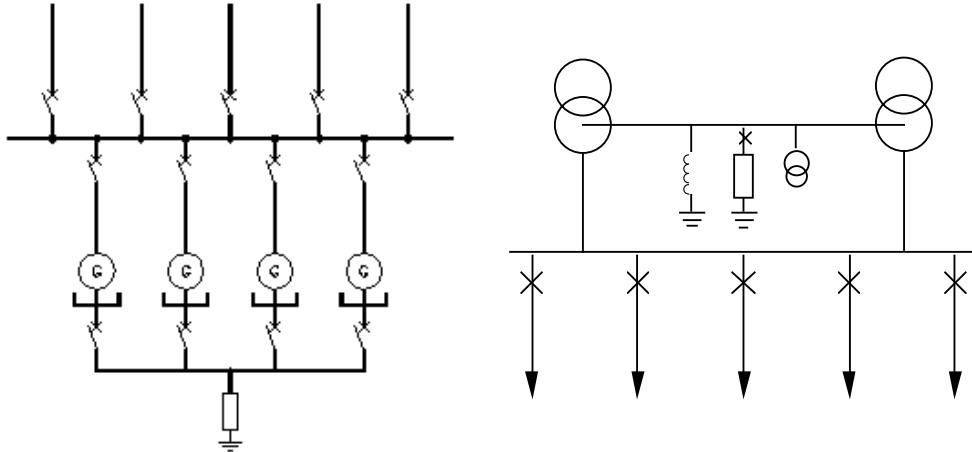

Figure 11. Resistance earthing, of the generator neutral-point, with a neutral busbar and individual neutral-point breakers.

Figure 12. Resonance earthing, of transformer neutral-point, with a neutral busbar and individual disconnectors.

Due to the third harmonic problem only one of the breakers in figure 12 resp. 13 should be closed at a time.

When one of the generators is taken out of service it's important that the corresponding neutral point breaker (or disconnector) is opened. This since the neutral busbar will be current carrying at an earth fault and achieve the phase voltage to earth.

## 6.3 COMMON EARTHING THROUGH A EARTHING TRANSFORMER ON THE BUSBAR.

An effective and often cheap way to make sure that the system always is correctly earthed is to connect any earthing transformer, according to section 4, to the busbar. See figure 13 which shows the same network as in figure 10 but with an alternative method of earthing.

---

### TO CHOOSE SYSTEM'S EARTHING POINT

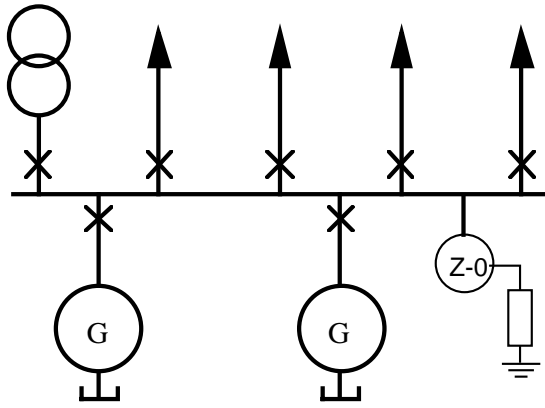

Figure 13. Earthing, with a Z/O-connected transformer on the busbar.

---

TO CHOOSE SYSTEM'S EARTHING POINT



# System Earthing

## 7. PRACTICE OF EARTHING

The practice of earthing differs very much from country to country. It is however possible to distinguish countries as Germany, Netherlands and Sweden etc., where the main direction has been to protect the telephone networks and people. It is also possible to distinguish countries as USA, Canada and England, where the power network protection has been considered first. The first mentioned countries has focused on limiting the earth faults currents to low values, while the latter countries has accepted the higher earth faults currents to prevent overvoltages in the power system and simplify fault clearance.

A summation of the practices in different countries would unfortunately be very extensive, especially as the networks differs even within the countries. However, a simplified summary follows below.

### 7.1 VOLTAGES OVER 100 KV

At high voltages there is an economic advantage in earthing the network directly (effectively). By doing so transformers and insulators etc. can be built with a lower test voltage at neutral and a graded insulation, which gives considerable cost savings.

In most countries it's normal with a direct earthing at voltages over 100 kV. In e. g. Germany, Netherlands and Norway, however there are 130kV networks with resonance earthing.

### 7.2 VOLTAGES BETWEEN 25 AND 100 KV

**USA** Most parts of the country are directly earthed but resistance and reactance earthing occur.

**ENGLAND** Most parts of the country are resistance earthed in the neutral-point of the power source. The resistance gives an earth

---

## PRACTICE OF EARTHING

fault current of the same size as the rated current in the transformer. Some 33 kV networks can however be resonance earthed.

GERMANY, SWITZERLAND, AUSTRIA, NETHERLANDS, BELGIUM, SPAIN, IRELAND, NORWAY, DENMARK, SWEDEN, JAPAN Uses resonance earthing.

### **FRANCE, SOUTH AFRICA.**

Most parts of the countries are resistance earthed (reactance earthing occur). France is investigating the possibilities of a change over into resonance earthing (with transient measuring earth fault protection).

AUSTRALIA Uses direct earthing and resonance earthing. Some 33 kV networks can however be resistance earthed.

NEW ZEALAND Uses direct earthing

INDIA, MALAYSIA Resonance earthing is the most common earthing but also resistance earthing occurs. And in India also direct earthing can occur.

## **7.3 VOLTAGES BETWEEN 1 AND 25 KV FOR DISTRIBUTION WITH OR WITHOUT DIRECT CONNECTED GENERATORS**

In most countries varying types of earthing can occur but the resonance earthing is the most common. However unearthed network as well as high resistance earthings can occur.

Resistance earthing is most common in USA and England.

Direct earthing is most common in Australia and Canada but can also occur in USA and Finland.

The earthing in Sweden, is mainly decided by §73 in Kommerkollegi standards, which says it's practically impossible to use direct, or reactance earthing concerning these voltage levels. This is due to high requirements on detection of fault resistances at

---

### **PRACTICE OF EARTHING**

# System Earthing

earth faults. Fault resistance values of 3000 resp. 5000  $\Omega$  are mentioned depending of type of feeder.

## 7.4 GENERATOR NETWORK

Generator networks, are the type of limited networks that consist of one or several generators connected to a primary transformer, but without direct connection to the distribution lines.

These limited networks are almost always high resistance earthed. However at new constructions unearthed networks rarely occurs.

## 7.5 VOLTAGES UNDER 1 KV

These networks are normally direct earthed. In industries with pure motor networks, unearthed or high resistance earthed networks are mainly used.

A special type of earthing, is used by the Swedish state power board in their “unearthed” motor network. The high resistance network has been replaced with a voltage dependent resistor. At earth faults a small current is created through the resistor and the network can be considered as unearthed. At flash-over from the network, at the primary side of the transformer (normally a high resistance earthed 10 kV network) the resistance in the resistor will be so low that the overvoltage in the low voltage network will be limited to 2 kV. See figure 15.

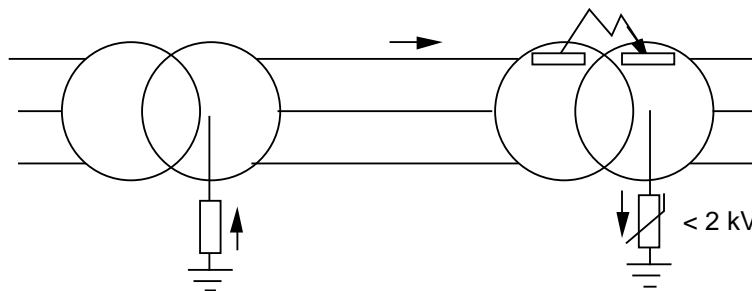

---

## PRACTICE OF EARTHING

*Figure 14. Earthing with a voltage dependent resistor, to limit the overvoltage, at a break-down of a high voltage network.*

# System Earthing

## 7.6 CHOICE OF EARTHING METHOD

It's rarely possible to change an already established earthing practice. At new deliveries or extensions it's therefore necessary to adapt to the already existing practice. Depending on the qualities considered important, the earthing that will give the most advantages and the lowest total cost solution, regarding the methods described in the following section is chosen.

## 7.7 COMPARISON OF DIFFERENT EARTHING PRINCIPLES

A comparison between different system earthing principles, can, based on the different parts according to table 1, be done. In the table resistance earthing is divided into low resistance and high resistance earthing depending on the effects regarding the damages from the current.

Tabell 1:

Type of earthing/ Feature	Solidly/ Effective	Reactance	Low resistance	Resonance	Unearthed	High Resistance
Damage of equipment	---	--	-	++	+++	++
Damage of property	--	--	-	++	+++	++
Person injuries	---	---	---	+	+	-
Arcing faults	+++	+++	+++	++	++	---
Overvoltage	+++	++	++	+	+	---
Ferro resonance	+++	+++	+++	+++	+++	---
Req on earthing grid	---	--	-	+	++	++
Apparatus insulation	+++	-	-	-	-	---

## PRACTICE OF EARTHING

Tabell 1:

Type of earthing/ Feature	Solidly/ Effective	Reactance	Low resistance	Resonance	Unearthed	High Resistance
Selective protection	++	+++	+++	+	-	-

**DAMAGES ON EQUIPMENT** Damages on the electrical equipment are normally pure quadrilateral dependent on the current and the fault time. Since “ $I_2t$ ” measures the energy, a lower current is a big advantage in limiting the damages. This is of major importance when rotating machines are included in the network.

**DAMAGES ON PROPERTY** Damages on property are depending on the current but normally in steps since damages on equipment (for example the telephone network) occur, when its durability is surpassed. The risk for fire due to an earth fault, follows the “ $I_2t$ ” relation. Note that for higher voltages there are such big distances to earth and between phases that a good protection exist in the physical construction. On distribution level the risk for damages on property is however of greater importance.

**INJURIES ON PERSONS**As mentioned earlier, some countries have chosen to keep the current low to protect people and property. Other countries have considered it as more important to optimize the system and ensure simple and fast fault clearance. The risk for injuries on persons can be divided into occurring step and touch voltages at primary faults of the power system.

Figure 16 shows the risk for injuries of people in an electrical accident and how contact and step voltages arises. The injuries consists partly of the risk for heart stop due to heart oscillation which occurs at 30 mA and the burn injuries in the skin layers at which the contact was made. The type of burn injuries are of course completely dependent on the current level.

---

## PRACTICE OF EARTHING

# System Earthing

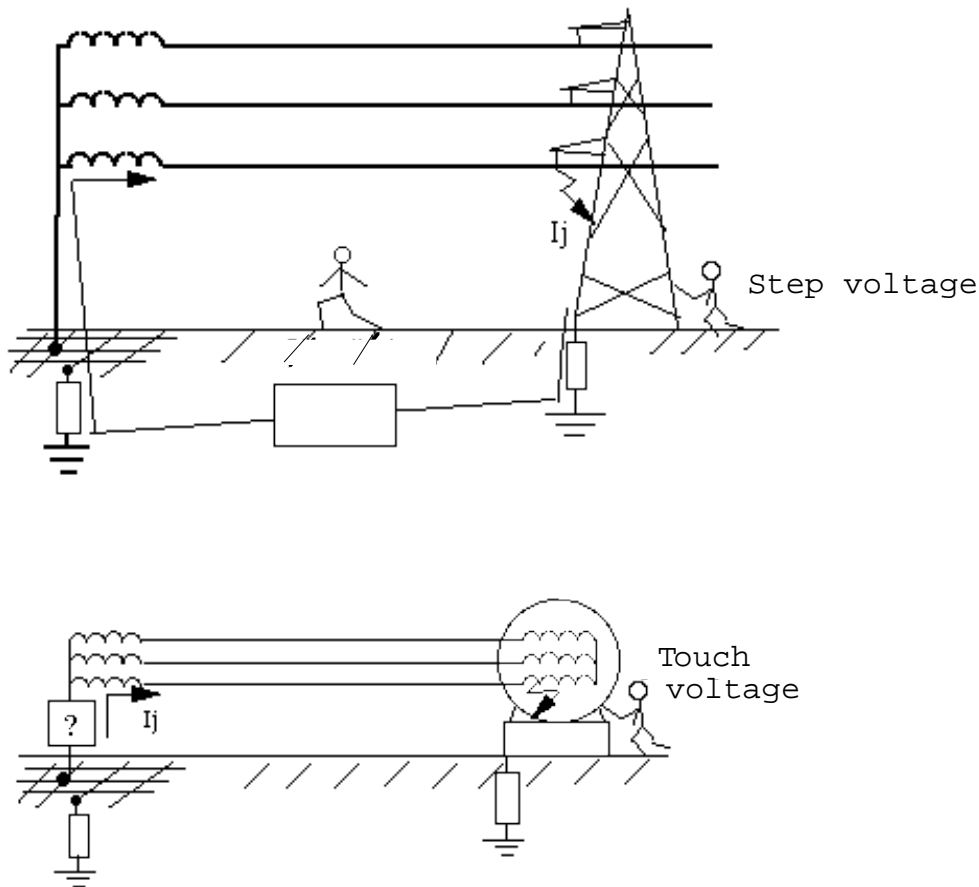

Figure 15. How the step and touch voltages, arises in a direct earthed network.

**TRANSIENT EARTH FAULTS** These consist of increased voltage at healthy phases during a reignition of the earth fault current after a zero crossing. A connection of the network to earth limits the overvoltages according to the previous discussion (See figure 3).

**FERRO RESONANCE** (See section 2.5). A system earthing limits the risk of ferro resonance in the voltage transformers. The un-earthed system, or systems who risks to be unearthed under certain operation circumstances, have a big disadvantage regarding the risk of ferro resonance.

**REQUIREMENTS ON THE EARTHING GRID** A limit set to the earth fault current reduces the requirements on the earthing grid since these are constructed to limit arisen step, and touch voltages, which in their turn are totally dependent of the fault current.

---

## PRACTICE OF EARTHING

**SELECTIVE EARTH FAULT PROTECTION** With the relay technique of today selective earth fault protection relays can be used in most networks (independent of system earthing). Directional protection relays, with sensitivities of a few Ampere primary operates on the transient and detects the earth fault even with high fault resistance. Modern Protection relays which measures fundamental or high frequency can successfully be used at earth fault protection.

Historically the using of selective earth faults was an important reason to choose a high earth fault current. In directly earthed transmission network that generates earth fault current from many points, the using of selective earth fault protection will be more complicated and require direction, inverse time characteristics and calculations on current distribution in all possible fault situations, to select settings which will give selectivity.

**APPARATUSES INSULATION TO EARTH** In an effectively (direct) earthed network a graded insulation can be utilized. This gives cost savings of 10-15% for voltages of type 130 kV. Regarding the apparatus prices at higher voltage levels a fully insulated zero-point and the requirements on the insulation becomes important. At voltages above 130-170 kV, nothing else but direct earthing is used.

## **8. DESIGN OF EARTH FAULT PROTECTION RELAYS**

An earth fault protection relay should be constructed to interact well with the system earthing method chosen for the network. The system earthing shouldn't be negatively affected by the requirements on the earth fault protection relays. In some cases, the system earthing can be chosen to make relays work more safely.

A few of these cases will be penetrated below and Earth fault protection is further discussed in a separate section.

### **8.1 PARALLEL RESISTORS FOR THE RESONANCE**

---

#### **DESIGN OF EARTH FAULT PROTECTION RELAYS**



# System Earthing

## EARTHING

The existence of the parallel resistor is only for making the use of selective earth fault protection relays possible. Since the resistor is disconnected during the time the resonance will work to distinguish the fault arc, the disadvantage with resistors is eliminated.

Today, this solution is used together with a quick auto-reclose instead of a previously used disconnection automatics and self-extinguisher. Tests have shown that self extinction of the short current wasn't possible since it was difficult to obtain a satisfactory calibration of the reactor to the capacitance in the network.

The resistor gives a possibility to instantaneous detection of the fault. This is done by a quick disconnection of the line and it can be connected again within 0,4 seconds with the fault point deionized. This solution has begun to dominate.

## 8.2 INCREASED CURRENT THROUGH THE RESISTOR AT HIGH RESISTANCE EARTHING.

In many cases the formula " $3R_0 \leq X_{C0}$ " for high resistance earthing gives a resistance which at full zero-point voltage only gives a few Amperes. To be able to install selective earth current protection the current must at least exceed 5 A. This normally gives no serious disadvantages as the current still is low and can therefore be accepted.

The highly sensitive earth current protection that is used in e. g. Sweden and Germany seems to be rather unknown in countries where low resistance earthing is of majority e.g. USA and England. This has resulted in that high currents in the resistance earthed networks have been chosen to make Normal inverse time relays (IMDTL) functional.

---

## DESIGN OF EARTH FAULT PROTECTION RELAYS

---

## DESIGN OF EARTH FAULT PROTECTION RELAYS

# Protection General

## 1. THE TASK OF THE PROTECTION SYSTEM

The protection system shall, together with the circuit breakers, disconnect faulty parts of the power system to:

- Protect the primary equipment against unnecessary damages.
- Save people in the vicinity of the electrical plant from injuries.
- Enable continued service in the undamaged parts of the network.

At an occurring fault in a power network the faulty part, and all other sections where the fault current is distributed to the fault, are exposed to abnormal forces and thermal stresses. Rotating machines can be thermally damaged at unsymmetrical faults due to occurring negative sequence currents.

The protection of the primary equipment must involve not only the faulty parts but also the other equipment in the network.

At electrical faults damages in the electrical environment can be caused by heat radiation, induction, rise of the ground potential etc. The protection of people and plants must satisfy the minimum requirements decided by the authorities.

In a power plant a strong electrical coupling of the different parts is often desired to minimize losses and voltage drops. A “strong” coupling like this may lead to major effects on the whole, or at least big parts, of the plant by a single failure. If not disconnected the fault will adventure the whole plant directly or by a domino-effect. A number of electrical faults are inevitable in a power plant. These faults can, only in exceptional cases, be allowed to adventure the operation of the whole plant, eventually also with other damages on apparatuses as a consequence. A satisfying fault clearance is therefor a necessary condition for an operative power plant.

---

### THE TASK OF THE PROTECTION SYSTEM

## 2. OPERATING CONDITIONS OF POWER SYSTEM

From the protection relays point of view the most important operation conditions can be classified and connected according to Figure 1.

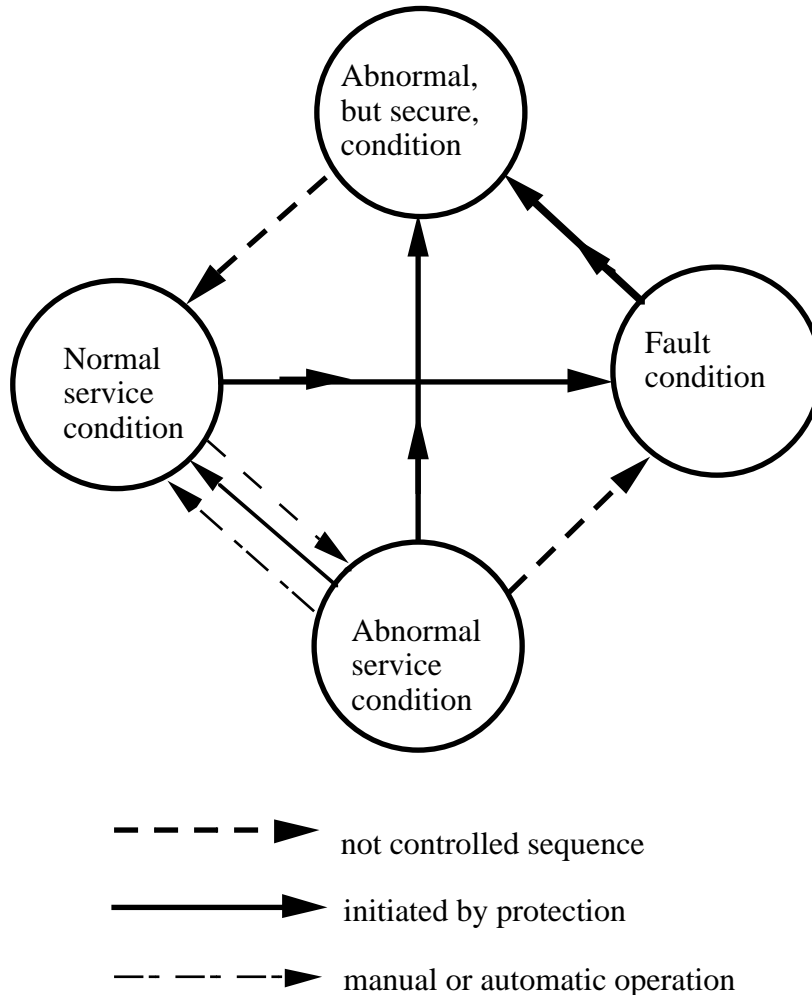

Figure 1. The power system's operation conditions.

Under normal operation condition the power plant fulfil its duties and all consumers will receive both nominal voltage and frequency.

Under abnormal operation condition all consumers will be fed with voltage and/or frequency which can be abnormal. Equipment parts of the plant can also be stressed out of limit values. These operation condition will after a short time lead to a fault condition if not corrected.

---

### OPERATING CONDITIONS OF POWER SYSTEM

# Protection General

The correcting measures can be initiation of regulation interference, disconnection of some parts of the load, connection of back-up capacity or, as a last possibility, disconnection of the critical apparatus. Mostly these precautions are initiated by protection relays which supervises the conditions in the electrical equipment. All these measures are preventive in the sense that they will be executed before a fault is created and before damages in the apparatuses occurs. However the apparatus is not totally uninfluenced. A cooling time may be required before the reconnection but reparation or exchange is not necessary. Effects like increased aging can still occur.

Under fault conditions the power plant is usually not able to fulfil it's functions as supplier of energy of acceptable quality to the consumers. At some faults the power plant can fulfil its functions but due to abnormal values the equipment will be stressed in such a way that sequential faults will occur and the power system will collapse. Even at faults where the consumers are not concerned the system will be stressed to a collapse if precaution not will be taken.

Faults can be of varying types (see fig 2).

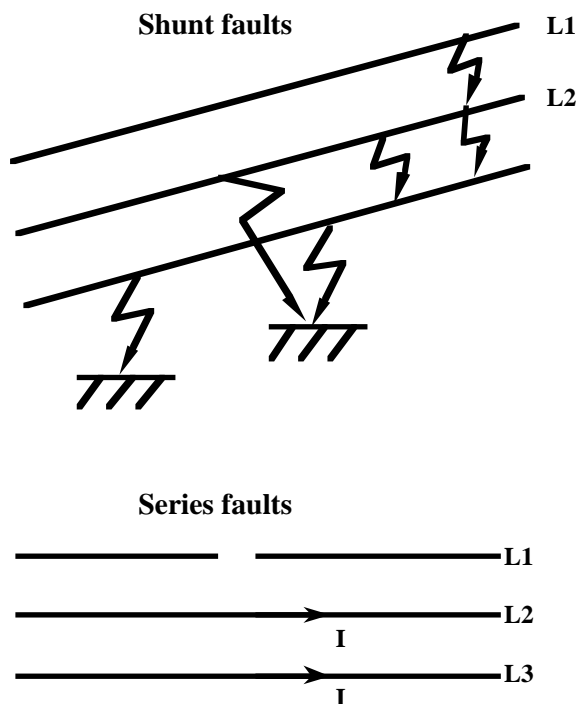

Figure 2. Different fault types in a power system.

---

## OPERATING CONDITIONS OF POWER SYSTEM

**SHUNT FAULTS** A fault current has developed due to insulation breakdown in one or several phases. These faults are called shunt faults and can be single phase to earth, two phase with or without earth connection, or three phase.

**SERIES FAULTS** A primary current loop has been broken into one or two phases. Such faults are called series faults.

The power system can not be allowed to be in service with a shunt, or a series fault under an unlimited time. The only practical operation is to disconnect the faulty part of the plant, so the system is put back at a abnormal, but safe, condition.

Theoretically at a series fault, a parallel link can be connected. This is not practically possible because such a link doesn't exist. A high impedance earthed cable network can be allowed to stay in service, during a limited time and under certain conditions, at a permanent earth fault. In these networks manual clearance of permanent earth faults is allowed. This will be initiated at an appropriate time for the operation.

In the "safe" condition, that will occur after faulty or abnormal service conditions, the consumer can get voltage of poor quality, or no voltage at all. In meshed networks the power system still can carry out its primary tasks even if the preparedness for interferences will be reduced. In case of a second fault the system can often no longer fulfil its duties.

The system must consequently as soon as possible return from the "safe" condition, to a normal service condition. To be able to reconnect the system parts, manually or automatically, knowledge about the cause of the fault is required to not increase the damages on the apparatuses or stress the system further. The protection relays must consequently, not only disconnect the faulty parts, but also diagnose the fault by indicating of which type it is.

The power system can be stressed by abnormal service conditions. Such abnormal conditions can be thermal overload, abnor-

---

## OPERATING CONDITIONS OF POWER SYSTEM

# Protection General

mal frequency or abnormal voltage. The power transfer is, under such conditions, maintained but the abnormal condition will, if maintained, develop to a primary fault.

Protection against abnormal service is therefor required in order to prevent unnecessary damage to the primary equipment.

## 3. REQUIREMENT ON PROTECTION SYSTEM

A basic requirement on the protection equipment is that it will clear the fault with sufficient speed to limit the consequential damages in the plant. Further the fault clearance must be quick enough to avoid a total, or partial, power network collapse.

At a primary fault speed is not of main importance, as the fault position has already been damaged and will require repairing. However, the consequential damages of other parts must be avoided. These damages are often of thermal nature as gas development, heat radiation and heating of conductor material.

A type of stress which can't be limited by the protection relays is the mutual forces between conductors leading fault currents. This stress will be fully developed at the first current peak. Since protection relays and the belonging breakers can't give a fault clearance time less than 2 cycles, the first current peak always will develop. These dynamic mechanical stresses can only be limited by fuses or special short circuit limiters which limits the progress of the current.

One requirement is insurance of a sufficient sensitivity to detect all possible shunt- and series faults. This also includes possible high resistive faults occurring at earth faults. An other requirement is that the high resistive faults should be detected after a limited time from when the fault is developed.

The protection relays today have a basically satisfying detection capability with the exception of overhead lines, where the detection of highly resistive earth faults isn't always considered com-

---

## REQUIREMENT ON PROTECTION SYSTEM

pletely satisfying without special measures.

The function of the protection relays to initiate the disconnection, is of outmost importance for the function of the whole power system. Therefore the protection relays must have a very high reliability.

A incorrect initiated trip of the circuit breaker will affect the power system negatively. Therefore a very high security against unnecessary clearances from the protection relays is required. The unnecessary clearances can be spontaneous or unselectable. The latter are functions due to a wrongly initiated operation for a fault outside the detection zone of the protection relay, executed by the protection relay. Consequently there are high requirements on the selectivity and reliability of the protection relays.

The operation capability of the protection system is summarized in “**reliability**”, which includes both the security in fault clearance and the security against undesired clearances. The security in fault clearance is called **dependability** and the security against undesired clearances is called **security**.

The reliability of the system depends on a lot of factors and generally the reliability of the total system is not better than the weakest component.

Example of factors which influences the reliability:

**THE PROTECTION SYSTEM** The engineer responsible must do a multitude of choices when a plant is projected. The protection system is chosen after voltage level, the weight of the plant, the possibility to have back-up functions, distribution of current faults and system earthing etc. The choices are also affected by the customs, the authorities and the economical situation. The system is chosen to fulfil the requirements on the plant and to give the lowest possible “Life Cycle Cost”.

**THE PRINCIPLES OF MEASURING** Different principles of measuring are used to protect the electrical plants. Every principle has its advantages and disadvantages and a choice of principle must be done based on access to measuring transformers, communica-

---

## REQUIREMENT ON PROTECTION SYSTEM



# Protection General

tion channels and demands on fault coverage at high resistive earth faults etc.

**ENVIRONMENT** Of course, the environment has affect on the reliability location in switchgear rooms, tropical and cold climate, heavy polluted environment etc., gives a lower reliability).

**THE SETTING OF THE PROTECTION RELAYS**A properly chosen measuring principle can evidently be totally ruined by an incorrect setting. A protection relay which, under back-up load conditions, operates unnecessary due to a too low setting can disconnect parts of the net

**THE MAINTENANCE** Independently of the quality of the protection system, a periodic maintenance must be executed. This includes test of relays and trip schemes. Bad design or construction solutions gives a difficult maintenance and thus a lower reliability.

**FLEXIBILITY UNDER DIFFERENT SERVICE CONDITIONS AND EXTENSION OF THE NETWORK** Since all network changes during its life time it's important that the protection equipment is chosen after a measuring principle, and has settings, to allow development of network and the varying service conditions.

## 4. CHOICE OF PROTECTION EQUIPMENT

The protection equipment is chosen to secure fault clearance in the power network. The base upon which the choices are made is the generally accepted “**Single Failure Criteria**” that says that a clearance must be executed even in case of a single fault in the clearance chain.

The fault clearance chain contains several components according to Figure 3 and failure of each component can prevent a trip function. It is therefore important that no part of the clearance chain will be executed with a lower reliability. A failure can never be totally excluded.

---

### CHOICE OF PROTECTION EQUIPMENT

Requirement in safe clearance imply, that there must be a back-up clearance function.

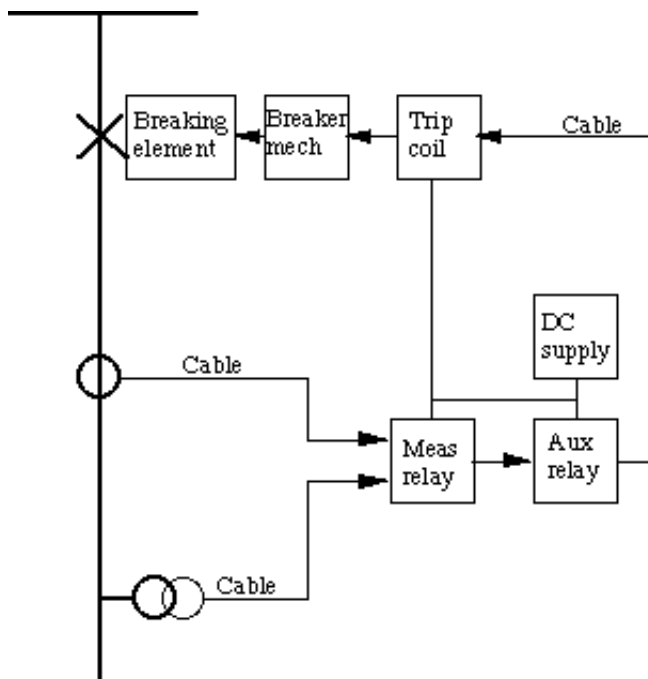

Figure 3. The different parts of the fault clearance chain.

This function can be executed either as a remote back-up or as a local back-up. The intention is that, even at a back-up tripping, an as small part of the plant as possible will be disconnected.

The single failure criteria can be fulfilled with a protection system including back-up protection. The back-up protection must be able to detect all primary faults, detected by the primary protection primarily intended to clear the fault. There are two different ways of arranging back-up protection:

**Remote back-up** is the most common way of arranging back-up in a distribution network. This means that the back-up protection is available at a separate breaker. Remote back-up is normally achieved through a time grading where the back-up protection is given a longer operation time than the primary protection.

**Local back-up** is used when remote back-up is difficult to achieve or when time grading for selectivity is not acceptable due to thermal limits or network stability reasons. Local back-up means that at the breaker location a second protection relay that

---

## CHOICE OF PROTECTION EQUIPMENT

# Protection General

detects the same faults as the primary relay shall be provided. The two systems are operating in parallel on the same breaker.

Selectivity is necessary for the back-up functions. There are two types of selectivity.

- Time selectivity, means that the protection relays, at the circuit breakers, have a graded time scale proportioned to each other.
- Absolute selectivity, which means that the relay can determine in what part, of the plant, the fault is located.

Remote back-up with time selectivity is most common at medium, and low voltage networks, where there is pure distribution and where two different relays, which opens two different breakers, relatively easy can detect all types of fault.

Figure 4 shows the primary and secondary zones in a distribution network. The protection zones are decided by the location of the current transformers.

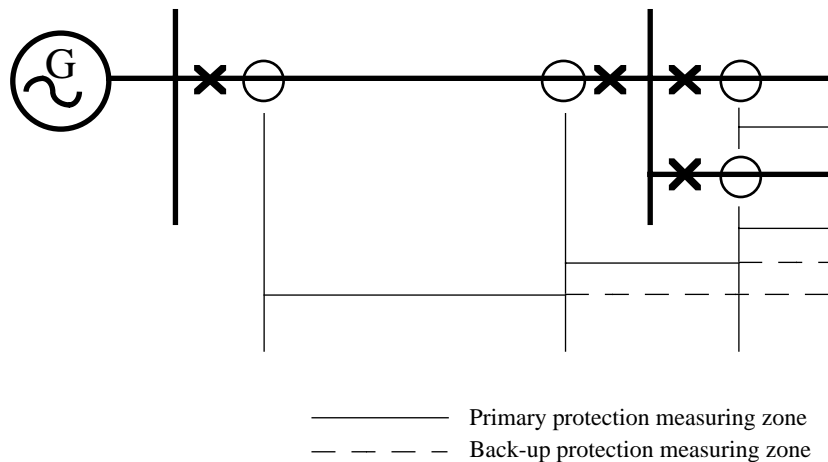

*Figure 4. Primary and back-up protection zones*

The back-up protection function, is arranged by time grading where the back-up protection relay has a longer fault clearance time than the primary protection relay (see fig 5).

In these cases it is necessary to consider even the battery system design, so that the protection equipment which gives a back-up for other protection equipment is not fed from the same

---

## CHOICE OF PROTECTION EQUIPMENT

DC supply. This is sometimes forgotten and can increase the consequences of a fault drastically.

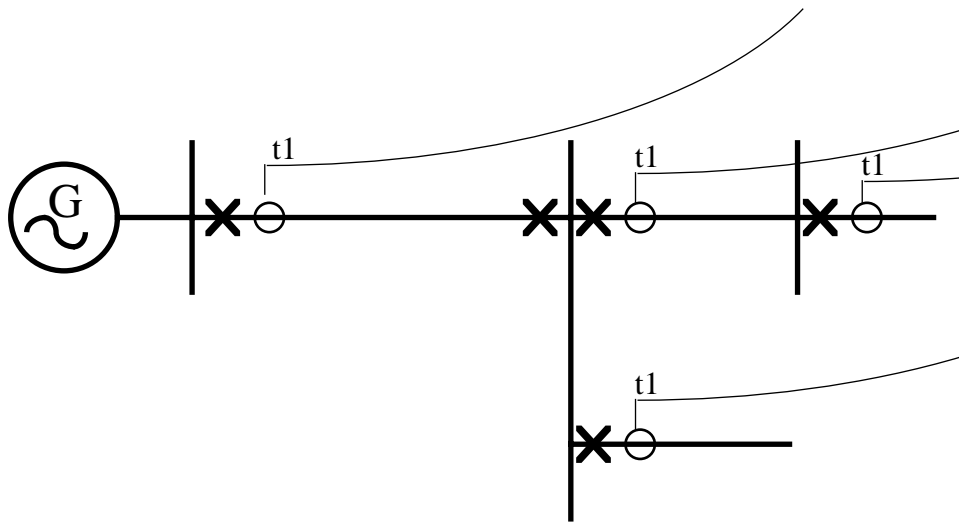

Figure 5. Back-up protection with time grading.

Take for example a fault at a distribution line. If this fault is cleared by the primary protection the damages will be limited. If the back-up function at the transformer clears the fault the damages has increased due to the increased clearance time. The increase will not be dramatically because the clearance time is within the thermal capacity of the transformer and the switchgear.

The next big step in the consequence stage occurs if the protection of the transformer fails. This can for example happen if both the line protection and the transformer protection are fed from the same DC supply which, for example, has disappeared due to a broken fuse

The relays further up in the system are not expected to recognize the fault (and normally they don't) so the fault will remain and thermally overload both the transformer and the switchgear. The clearance is obtained only when the transformer collapses and the fault is cleared by the relays further up in the system. The consequences have then increased drastically.

In cases where a remote back-up can't be arranged for example when there are difficulties in detecting the fault at an object from

---

## CHOICE OF PROTECTION EQUIPMENT

# Protection General

an adjoining object, a local back-up must be arranged. This can be the case at long distribution lines where a fault in the remote part never can be detected by the relay at the feeding transformer, due to the small increase of current which appear at the transformer. A parallel overcurrent relay can be inserted and trip on another trip coil.

In the meshed transmission network where fault currents are fed from all directions normally a local back-up must be used. The local back-up can be delayed, with a local relay at the object which detects fault within the same, or a wider zone than the primary relay but takes a longer time to trip.

The most common at high voltages, is to use double identical relays called redundant relays. The redundant protection system gives an improved reliability.

A normal practice at using redundant protection systems is to:

- Separate measuring cores used in measuring transformers (of economical reasons it is very rare to use double measuring transformers).
- The circuit breaker is not doubled, due to economical reasons, but provided with double independent trip coils.
- The DC distribution will be separated as far as possible. At higher voltage levels, double battery systems will normally be provided.
- The protection systems are placed physically separated and often also separate cable ways are used.

---

## CHOICE OF PROTECTION EQUIPMENT

In Figure 6 the fault clearance chain with redundant protection system is shown.

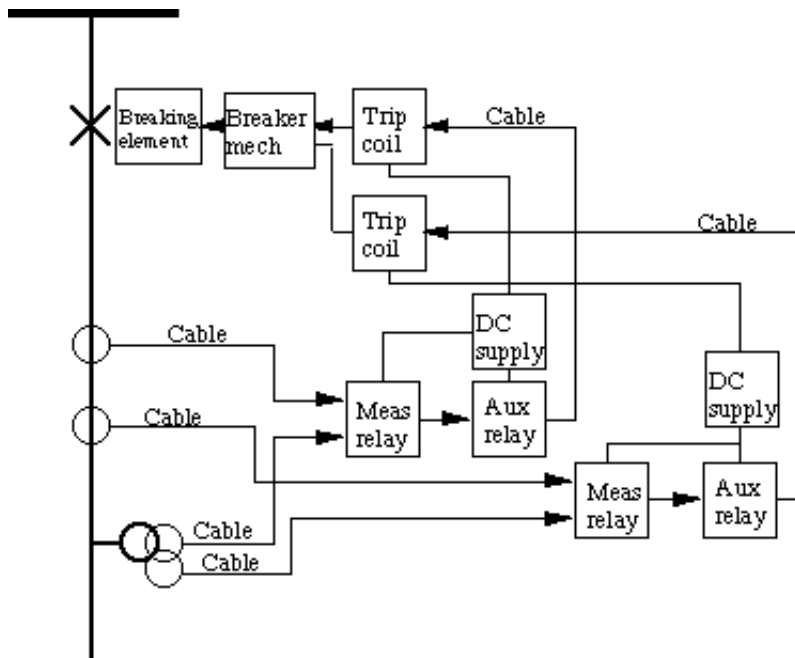

Figure 6. The fault clearance chain at redundant protection systems.

Due to the cost of the breaker this will not be doubled but it will be provided with double trip coils. However, a small risk for breaker failure still exist according to statistics. To ensure fault clearance in case of breaker failure, and secure a short fault clearance time, a breaker failure function is included (see fig 7).

The breaker failure function will trip surrounding breakers if one breaker would fail.

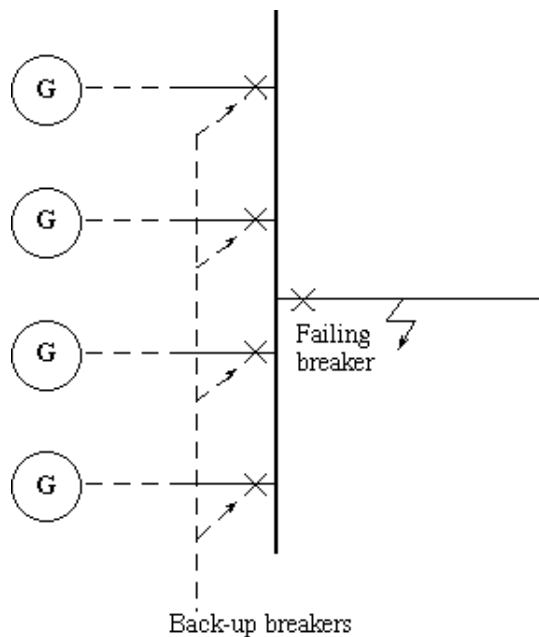

Figure 7. The principle of a breaker failure protection.

## CHOICE OF PROTECTION EQUIPMENT

# Protection General

Due to the big impact for the operation of the network that a breaker failure trip causes, very high requirements are set on a breaker failure relay security against unwanted functions.

A breaker failure is designed with high internal security. The current through the breaker will be controlled after a trip attempt and if it don't disappear in a reasonable time (less than 60 ms), a breaker failure exists and the surrounding breakers will be tripped. Often a "2 out of 2" connection of the current and time is sometimes used to obtain highest possible security against unnecessary operations. For new numerical products the same risk of failures of a current detection relay or a time-lag relay do not exist and the "2 out of 2" is not any more required.

A duplication of the breaker fault function gives a higher reliability but at the same time a lower security which is a disadvantage. Due to the minimal risk of a breaker failure, and the negligible risk that the breaker failure relay fails at the same time, only one breaker failure relay is used.

The most important in the choice of protection equipment is that desired trip security is obtained. After that the cost for the different alternatives must be considered where the guiding principle is the Life Cycle Cost.

The cost for operation and maintenance must be considered. Redundant protection systems cost more to install as well as under its life time. However big savings can be made in the primary system by securing the short fault clearance time. The primary apparatuses can then, for example, be dimensioned for 0.5 seconds thermal capability instead of 1.0 second. Furthermore a later rebuilding can be avoided when the network is to be extended to a more meshed configuration with higher fault levels.

---

## CHOICE OF PROTECTION EQUIPMENT

## 5. DISTURBANCE REGISTRATION AND FAULT SIGNALLING

The fact that the operation personnel will be informed of all fault signals is as important as all other parts in the fault clearance chain. If the design is well designed with alarms for problems in the DC system, but that alarm won't reach the responsible personnel, the alarm is of no use. This means that the design of the DC supply distribution for the alarm system is very important. Alarms must not be attached to the same group as the distribution and the alarm voltage must always be supervised.

To be able to follow a protection system's behavior when the network changes and to make sure that a fault really will be cleared, a disturbance recorder and an event recorder can be used. These two devices register all important signals in case of a disturbance. The analysis of the print-out is an excellent complement to the maintenance. This analysis is made from print-outs from both the line in question and the surrounding lines, which gives a possibility to discover inoperative relays as well as incorrect settings and badly chosen measuring principle.

This global analysis has a great value in changing the network world.



## 1. INTRODUCTION

The transmission lines are the most widely spread part of the power system and the overhead lines are the, from environmental influences, least protected part of the system. The number of line faults will thus be very high compared with the total number of faults in the whole power system. Therefore the line protection are one of the most important protection systems in the whole power system.

Another aspect is that the power lines are the part of the system that is most likely to cause injuries to people and also to cause damages to equipment and structures not part of the power system. Therefore the line fault clearing is subject to authority regulations.

In the voltage range above 170 kV, practically all systems are solidly earthed. In the range 50-170 kV some systems are earthed over Petersén reactors. These systems are seldom equipped with earth fault protection relays. Earth faults are then cleared manually or with special transient measuring protection relays. The clearing of multi-phase faults will basically not be different in these systems than in solidly earthed systems. Systems with Petersén reactors will therefore not be discussed separately.

Overhead lines in the voltage range of 170 kV will have a length from a few up to approximately 400 km. Cable lines are limited to a maximum length of about 20 km.

Some lines are mixed and consist of both cable and overhead lines. Cable and overhead lines have different phase angles and "Z0/Z1" ratio. These differences complicates the impedance diagram for the mixed lines where the cable impedance can't be ignored in relation to the overhead line impedance. Mostly the cable is short and the mixed line can be handled, from protection point of view, as an overhead line.

## 1.1 FAULT STATISTICS

The probability of line faults, caused by lightnings, are 0,2-3 faults per 100 km and year. To this have to be added faults caused by pollution, salt spray, swinging conductors, lifting devices touching the conductors. In most cases lightning faults are much dominating.

About 80% of the line faults are single phase to earth, 10% are two phase to earth faults, 5% are isolated two phase faults and 5% are three phase faults. At lower voltages the multi phase fault will be more common due to the lower basic insulation level. The number of faults also increases due to the lower distances.

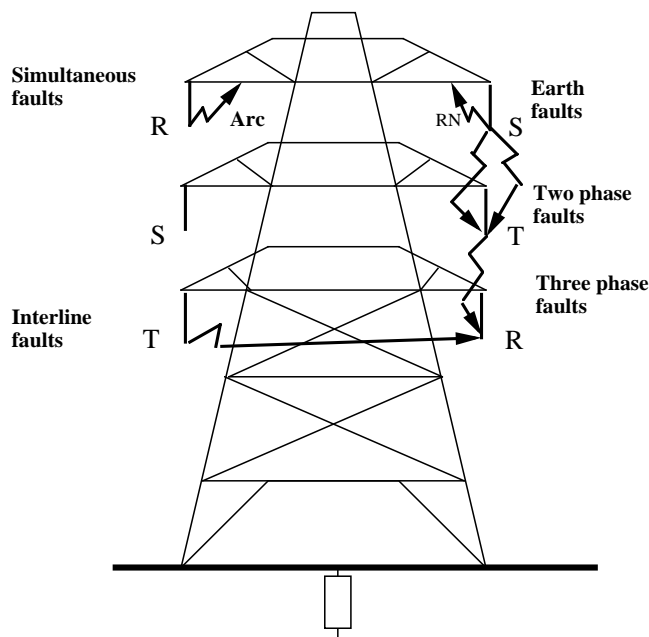

Figure 1. Faults occurring on a transmission line tower are of different types.

## 1.2 FAULT TYPES

**Transient faults** are common on transmission lines. They will disappear after a short “dead interval” and self distinguish. Lightning is the most common reason for transient faults. The by lightning induced overvoltages will cause flash-over in an insulator chain.

# Line protection

The fault must be cleared to clear the arc. After a short interval, to allow deionisation, the voltage can be restored without causing a new fault.

Transient faults can also, further to lightnings, be caused by factors such as swinging lines, falling trees and birds.

Approximately 80-85% of faults at HV lines are transient. The figures appearing at lower voltages are less.

**Persistent faults** can be caused by a broken conductor, a falling tree, a mechanically damaged insulator etc. These faults must be localized and the damage repaired before the normal service can be reestablished. The system is during the reparation in an abnormal but safe condition.

## 1.3 SPECIAL FAULT TYPES

In double circuit lines (two lines at the same tower) simultaneous and inter-line faults can occur.

**Simultaneous fault** are most likely to be two single phase to earth faults that will occur on different phases on the two lines on the same transmission line tower. Both faults will though then be in the same tower. The common footing resistance will complicate the detection of this type of fault.

**The Inter-line fault** is a connection between two phases of the parallel lines on the same transmission line tower with the arc. The probability for simultaneous fault and interline fault is low.

The fault resistance at a multi-phase fault consists only of arc resistance and can practically be ignored. At cross country faults, an earth resistance is added to the arc resistance and the fault resistance will then be significant. The probability for this type of fault is very small in a solidly earthed system and is mostly ignored. In systems earthed over Petersén reactors where fault is not immediately disconnected this type of fault can't be ignored.

---

## INTRODUCTION

The fault resistance can't be ignored in case of an earth fault. When the fault occurs at a tower the footing resistance is added to the arc resistance. The footing resistance depends on the line design and is almost always less than ten ohms but the resistance can be tens of ohms in extreme cases. When earth faults between the towers, called mid-span faults, occurs the footing resistance is beyond control and can in extreme cases be up to tens of kilohms. Mid-span faults can be caused by growing trees, bush fire or objects touching the phase conductors.

One very serious type of mid-span faults are caused by mobile cranes. The mid-span faults have to be payed special attention due to the risk of injuries to people if they not are cleared properly.

## 2. REQUIREMENTS ON LINE PROTECTION

The choice of protection relays for a specific application, depends on the network configuration, type of line (single or parallel, long or short, series compensated or not), load current level, and expected tower foot resistances etc. A choice must be done individually for each application and the future expansion of the network must be kept in mind.

The most important features of the line protection relays are:

### ***Speed***

Speed i. e. short operating time for severe faults.

As mentioned above a very short clearance time is required for severe faults, sometimes down to a few milliseconds. One example is a three-phase fault in a 400 kV system having 20 kA in short-circuit current and 13000 MVA in short circuit power. The thermal and mechanical stresses at such a fault are very high.

Speed is thus important to:

- limit the damages on the high voltage apparatus as well as limit the thermal and mechanical stresses.

---

## REQUIREMENTS ON LINE PROTECTION

# Line protection

- limit the ionization at the fault which will increase the chances of a successful Auto reclosing and thus shorten the dead interval.
- increase the power transmission capability of the network without decreasing the safety margin for the network stability.

**REQUIREMENT ON SPEED** The maximum fault clearance time is important i. e. including the back-up protection function and the possibility of a breaker failure. The network must be stable under maximal conditions. Times from 250 ms up to several seconds can occur depending on line type, location in the network, sources etc.

## ***Sensitivity***

Sensitivity means the capability to detect all types of fault.

It is important to detect all faults even if the fault current is smaller than the load current. Equipment damages due to induction in low voltage equipment, or person injuries due to rise in earth potential, can occur also for low magnitude faults. High resistive earth faults are quite likely to occur at long transmission lines and the relay system must be able to detect such faults before the faults develop further or people will get seriously injured. Sensitivity is therefore the second important aspect in the performance of line protection relays.

**REQUIREMENT ON SENSITIVITY** The requirement on the line protection systems sensitivity at earth faults is often discussed and varies between utilities. The mid-span fault often requires higher sensitivity than what can be achieved by the primary protection relay used. A maximum sensitivity of approximately " $R_F < 50 \Omega$ " can be achieved by the primary protection.

An acceptable sensitivity can only be achieved utilizing zero sequence components in overcurrent, directional overcurrent or directional comparison schemes. These relays can only detect earth faults.

## ***Selectivity***

Selectivity i. e. the capability to determine the fault location and only disconnect the faulty object.

---

## **REQUIREMENTS ON LINE PROTECTION**

The consequences of a fault must be limited and the power supply to the consumers secured. The protection system must therefore be capable of distinguish between an external and an internal faults also for low magnitude faults on a heavy loaded object, or for parallel objects where close to similar parameters exist for both healthy and faulty object.

### **Requirement on selectivity**

In order to fulfil these requirements the protection relays has to be able to distinguish between the normal operating condition of the protected object and an electrical fault i.e. give a reliable fault detection unaffected by normal operating conditions such as load, inrush currents etc. In some cases it is also required that the protection relay must be able to detect also other abnormal operating conditions such as overexcitation, overload, broken conductor etc. These aren't electrical faults but may still damage the protected object or other apparatus in the network. Since power apparatus in many applications have to operate near their rated limits it is important that this part of the protection system exactly can distinguish between permissible and none permissible operating conditions.

Electrical faults are normally required to be cleared instantaneously. Other abnormal operating conditions, can be accepted to result in time delayed action.

Dependability and security are contradictory to each other but have to be evaluated together due to the linking of the two qualities. In redundant protection schemes the whole scheme has to be evaluated not only the individual relays.

To achieve maximum dependability combined with maximum security the communication demands shall be at minimum. Wide band transmission is not only expensive it will also be more exposed to interference. The latter is apparent when power line carrier is used. The communication demand is therefore linked with dependability and security.

---

## REQUIREMENTS ON LINE PROTECTION

# Line protection

Operate time, sensitivity and dependability are contradictory to security, therefore none of the first qualities have to be exaggerated.

## 3. MEASURING PRINCIPLES

The basic type of measuring principles can be used for line protection relays. One, or combinations, of the measuring principles below can be used to create the total line protection scheme.

***Overcurrent protection relays*** are unidirectional, or directional, current measuring relays with a back-up feature due to the current measuring principle.

***Pilot wire, optical line differential and phase comparison measuring principles*** gives exclusive unit protection without any back-up feature. New types of Optical line differential relays with Distance back-up functions do now exist on the market which solves the back-up function problem.

***Distance and directional impedance measuring principles*** basically gives time/distance selective protection with a back-up function. By using communication an unit protection function can be achieved together with the time/distance function with back-up.

***Travelling wave protection*** is a unit protection where the two line ends are communicating through a fast channel in a permissive or blocking scheme.

### 3.1 OVERCURRENT RELAYS

Overcurrent relays are normally used in networks with system voltage below 70 kV where fault infeed is from one direction only and where relatively long operating time is acceptable. At higher voltage levels in the transmission lines the directional, or unidirectional, overcurrent relays are used as back-up protection to the instantaneous primary protection relays. The overcurrent protec-

---

## MEASURING PRINCIPLES

tion will then operate as a back-up to the primary protection and for special types of faults e. g. high resistance earth faults which cannot be detected by the primary protection.

## 3.2 PILOT WIRE, OPTICAL LINE DIFFERENTIAL AND PHASE COMPARISON RELAYS

### Introduction

Pilot wire and phase comparison relays are unit protection relays, which only detects faults in the zone between the relays. No back-up function is included, so a separate back-up relay is normally required.

Optical line differential relays are also unit protection normally without back-up function. However there exists now such relays with a built-in back-up Distance protection function.

Communication between line ends is required and can be accomplished with any of the following:

- Pilot wires
- Power line carrier
- Radio link
- Optical fibre

**Pilot wires** can be placed in soil or at towers. The resistance will limit the possibility to use pilot wires. The use is mostly restricted to distances less than 10km.

**Power line carrier (PLC)** equipment is based on a capacitive connection of signals, with a frequency of 50-500 kHz, in the power line. A frequency keying is normally used to transmit a trip, block or phase angle signals to the remote end.

PLC equipment can also be used in very long lines and for remote control.



# Line protection

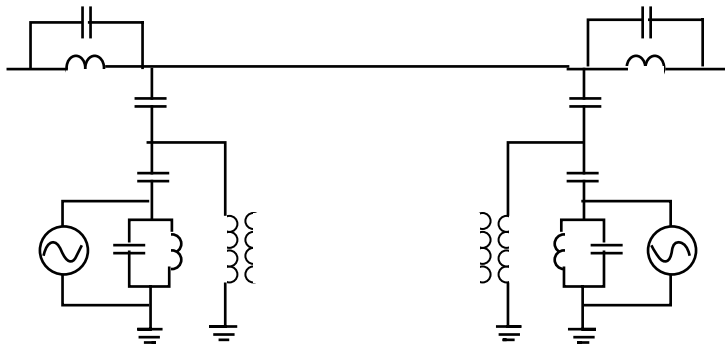

Figure 2. Communication through a high frequency signal, interposed at the high voltage line (PLC).

**Radio links** are reliable, but expensive, communication links and are therefore rarely used.

**Optical fibres** have two big advantages, the insensitivity to noise and its possibility to transmit huge amount of information. An increase in the use of optical links have been noticed during the last number of years. Cost has decreased and new Optical line differential relays utilizing the transmitting capability has been developed giving improved protection capability. See separate section below.

## Principle design of pilot wire differential relay

Pilot wire differential schemes gives an absolute selectivity and a short operating time. It can use wires of metal or, with recent developed relays, optical fibres. The use of optical fibres in transmission tower top lines will increase during the forthcoming years, and several new products using optical fibres will be available. Probably also combined products where a single phase differential relay is combined with back-up functions, the lack of which up to now have been a draw-back for the pilot wire differential relays.

## ***A short description of the pilot wire differential relay principle:***

The measuring principle is based on a comparison of amplitude and phase angle at the two line ends according to the differential

---

## MEASURING PRINCIPLES

current principle (Kirchhoffs first law). A relay is of practical reasons, provided at each line end to detect the faults and to trip the circuit breakers.

A summation transformer is often used to transform three phase systems into single phase form enabling the use of one pair of pilot wires only. With the voltage balance principle, the current unbalance is changed into a voltage balance. The principle of a voltage balance differential relay is shown in fig 3.

A relay with a matching current ratio is connected to the current transformer at the line ends (1 A can be used at one end and 5 A at the other but the same primary current is required). The pilot wires resistance " $R_p$ " and the settable resistor " $R_p/2$ " are connected to the secondary of the summation transformer. A relay is connected between the pilot wire terminal and the mid-point of the summation transformers secondary winding. These points will with the used dimensioning of the pilot resistance and the built in resistor have the same potential at normal service conditions (see fig 3a).

---

## MEASURING PRINCIPLES

# Line protection

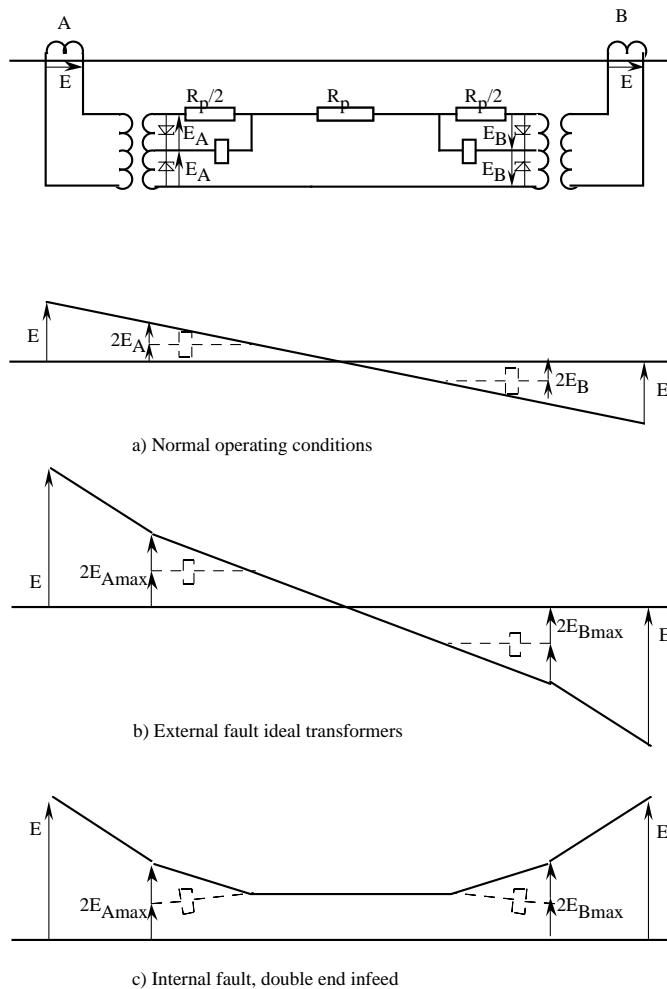

Figure 3. A voltage balance current differential relay

At high through fault currents the voltage across the relay will be zero although the voltages “ $2E_A$ ” respectively “ $2E_B$ ” will increase to the maximum value “ $E_{Amax}$ ” respectively “ $2E_{Bmax}$ ”, dependent of the two regulating diodes. The relay operating voltage is selected to prevent maloperation due to small differences e. g. caused by saturation of current transformers cores (see fig 3b).

If a fault, fed from both directions, occurs within the protected area the summation transformers outputs will be in phase opposition. No currents can therefore circulate in the pilot wires. The secondary voltages will be limited by the regulating diodes to “ $2E_{Amax}$ ” resp. “ $2E_{Bmax}$ ”. Operating voltages will occur across

## MEASURING PRINCIPLES

the relays and the differential relays at both end will trip (see fig 3c).

Also at an internal fault fed from only one line end, voltages will occur across the relays and both relays will operate (see fig 3d).

### Principle design of Optical line differential functions

The optical line differential functions have been introduced on the market during the last number of years together with the start of provision of optical fibres between the two stations, giving a broad band connection enable direct differential measurement on a phase per phase basis.

The differential current principle is shown in figure 4. One relay is provided at each line end. The communication can be through separate dedicated fibre, through a MUX'ed 54/64 kbit/s channel complying to CCIT and EIA standards or even through separate pilot wires in special cases.

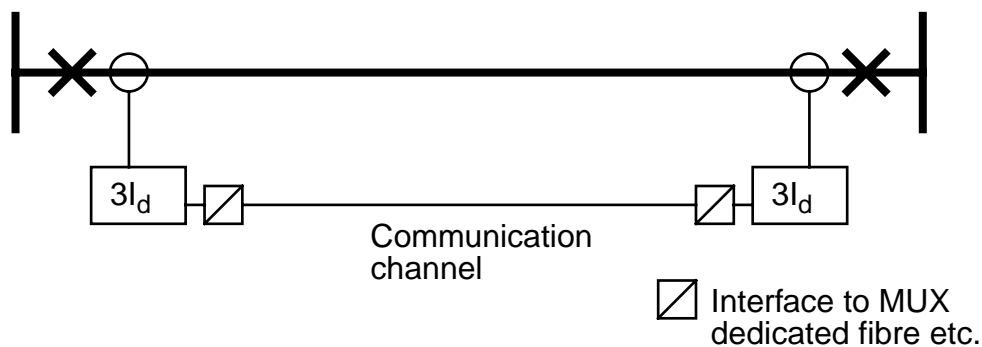

Figure 4. The principle for an optical line differential relay with one protection relay at each line end communicating through a communication channel.

The differential measurement is stabilized with the current scalar form as per below figure 5. The degree of stabilization for through faults and the minimum operating current is settable. Modern relays also normally have a CT supervision detector to lower the requirement on current transformer cores.

An advantage with these modern optical relays based on numerical principles is the possibility to set the CT ratio adaption. Different CT ratios can then be used at the two line ends.

---

## MEASURING PRINCIPLES

# Line protection

An intertrip channel for direct intertrip from e. g. Breaker failure protection is normally also available in the relays.

In some types of relays the differential functions can be complemented with an back-up protection in form of a Distance protection or a simple short circuit and earth fault protection. This function can then operate in parallel with the differential function or only as a back up when the communication channel is missing.

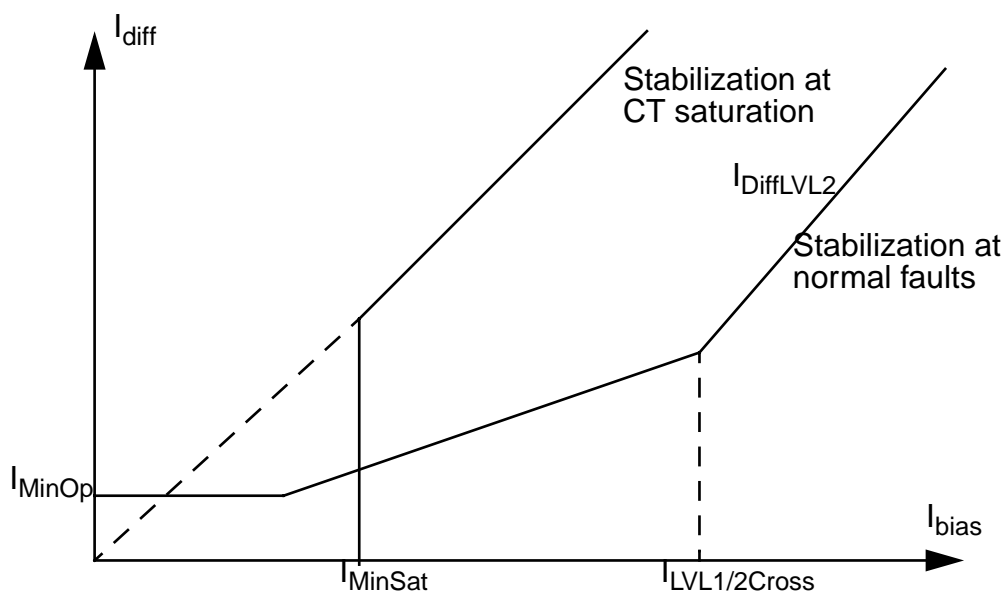

Figure 5. The stabilization characteristic.

## Principle design of phase comparison relay

Phase comparison relays is used in some countries. However the relays haven't been able to take big market shares mostly because of the fact that they provide only unit protection not including any back-up functions, but also due to the high requirement on a fast communication between ends which mostly means a separate PLC equipment for this protection relay only.

The "phase comparison principle" indicates that the phase angle of the current at the two line ends are compared each cycle as shown in figure 6.

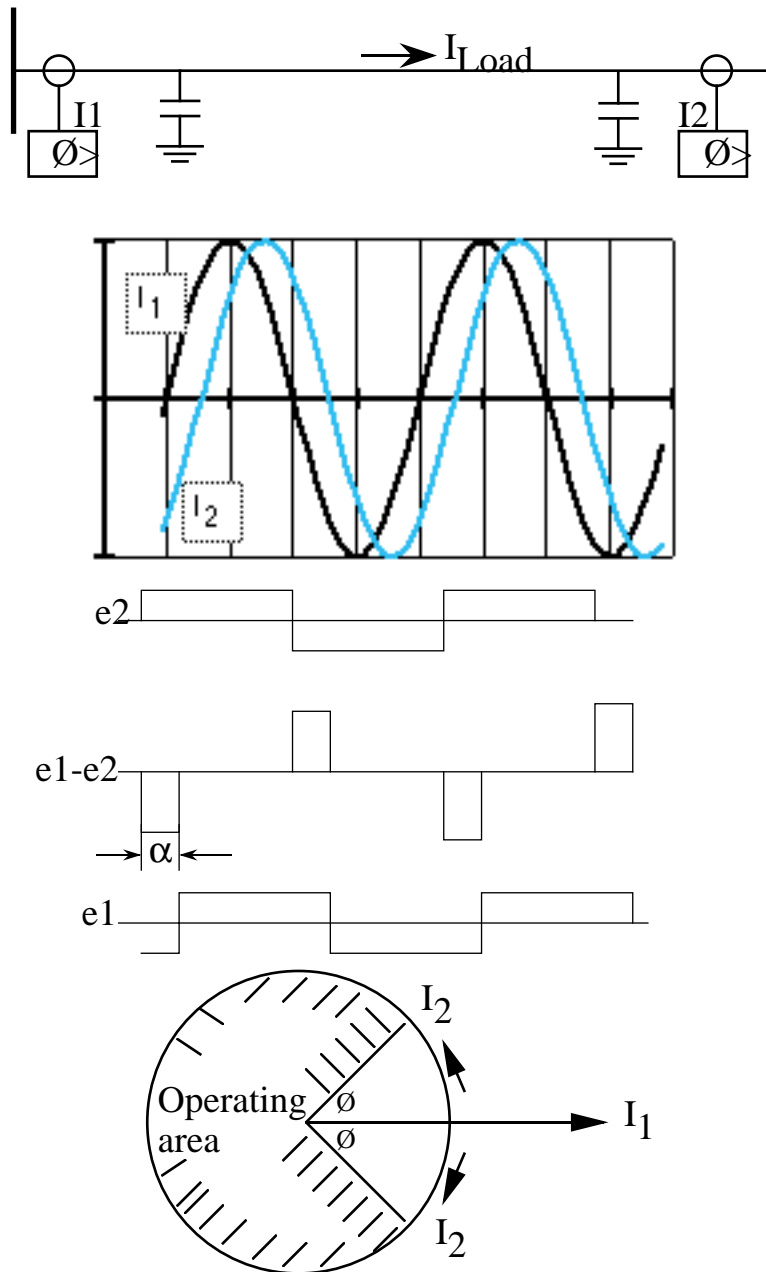

Figure 6. Measuring principle of a phase comparison relay. The angle difference, between the currents at the two line ends, is compared.

The measured time for the zero crossing is transmitted to the other end with a short, and well defined, channel time.

At normal load, or through faults, the phase angle at the two ends is rather alike. A small difference will though occur due to the capacitive generation of the line. An amplitude requirement is often added to the phase angle requirement.

To limit the transmission of signals to fault conditions a start criteria is normally added. Overcurrent, Overcurrent/Undervoltage,

---

## MEASURING PRINCIPLES

# Line protection

Impedance or combinations of all above can be used as start elements.

## 3.3 DISTANCE AND DIRECTIONAL IMPEDANCE PROTECTION

### Principle design

Distance protection relays are the most common relays on transmission lines. The reason for this is the simple measuring principle, the built-in back-up and the low requirement on communication with remote end.

The Distance protection relay is a directional underimpedance relay. Normally two to four measuring zones are available.

Basically the Distance protection relays measures the quotient “ $U/I$ ”, considering also the phase angle between the voltage “ $U$ ” and the current “ $I$ ”. The measured “ $U/I$ ” is then compared with the set value. The relay will trip when the measured value is less than the value set. The vector “ $Z_L$ ” in figure 7 shows the location of a metallic fault on a power line in the impedance plane. Power lines normally have impedances of 0,3-0,4  $\Omega/\text{km}$  at 50 Hz and the angle normally is 80-85°.

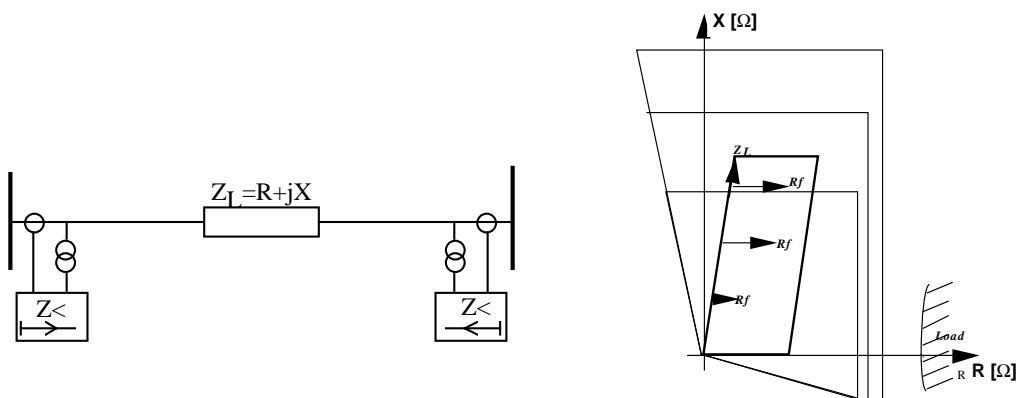

Figure 7. The principle of a Distance protection relay.

However, metallic faults are relatively rare. Most faults are caused by a flashover between phase and earth or between phases.

---

### MEASURING PRINCIPLES

A small arc resistance “ $R_f$ ” exists in the fault. The arc resistance  $R_{arc}$  can according to Warrington be calculated as:

$$R_{arc} = 28700 * a / I^{1.4}$$

where:

$a$  is the length of the arc in m i. e. the length of the insulator for earth fault and the phase distance at phase faults.

$I$  is the fault current through the fault resistance in A.

During earth faults, the tower foot resistance also will occur in the fault loop. The Distance protection relays must therefore cover an area of the line impedance, plus the fault resistance as indicated in the figure. Tower foot resistances should normally be kept below 10  $\Omega$ . Top lines connecting towers together will give parallel path and lower the tower foot resistance.

In some areas as high values as 50  $\Omega$  can exist and special precautions to protect against earth faults can then be necessary.

The vector “ $Z_b$ ” shows the location of the load impedance. Normally the load impedance is close to “ $\cos \phi=1$ ”. The Distance protection relays must be able to distinguish between fault and load conditions even if the impedances are of the same size.

The detection of the forward direction is an important function for a Distance protection. The directional sensitivity must be absolute and serve down to zero voltage.

The back-up function is simply achieved, by an extension of the impedance reach with time steps (see figure 8).

For normal lines with a distance longer than approximately 15 km the first step of impedance, is underreaching the line end with absolute selectivity covering about 80% of the line. The 80% reach is selected due to errors in distance measurement due to Current and Voltage transformer errors, relay accuracy and influence from the system as described further below.

A fault at “**F1**” will be tripped instantaneously from both protection “**A**” and “**B**”. Normal operating time in modern Distance protection relays is 15-30ms. Operating time will be dependent on source to impedance ratio, setting, fault resistance, fault position, CVT filter and the point of wave at which the fault occurs.

---

## MEASURING PRINCIPLES



# Line protection

A fault at “F2” is tripped instantaneously by relay “B” and by relay “A”, after the time “t2”.

A fault at “F3” is normally tripped instantaneously by relay “C” and “D”. If the relay at “C” or the breaker fails, relay “A” will trip.

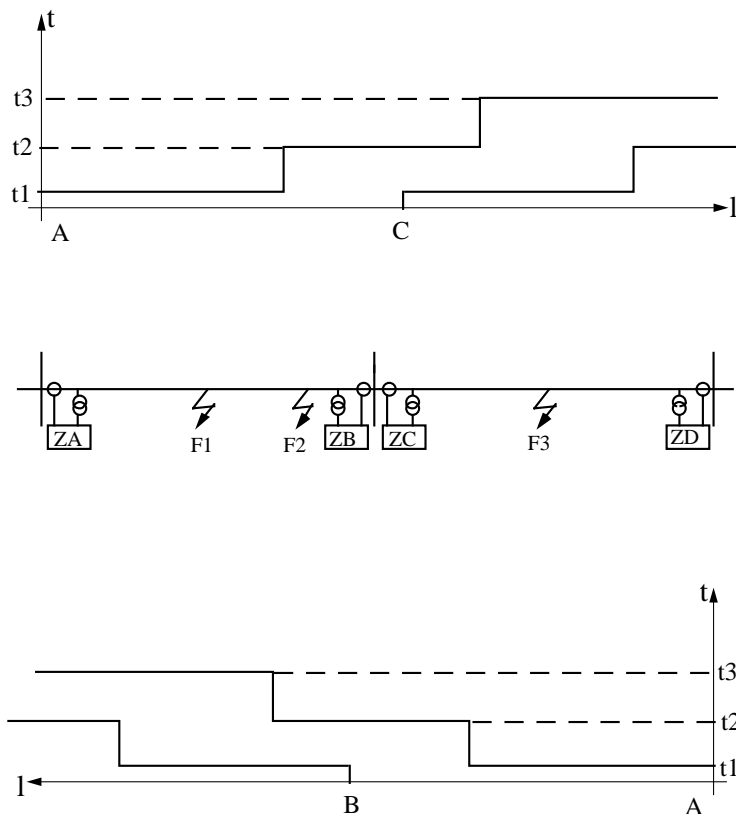

Figure 8. The principle of line protection, with Distance protection relays at both line ends.

## Distance protection relay -Design

The design of a Distance protection is much dependent of the technic used. Today there are products of electromechanical and static, as well as numerical, design. However the numerical schemes have clearly started to take over.

The two main types of Distance protection relays are “switched scheme” and “full scheme”. The switched scheme relays consists of a start relay selecting the correct measuring loop to the single measuring relay. The start relays are in their simplest form cur-

---

## MEASURING PRINCIPLES

rent relays at all three phases and in the neutral. In more expensive solutions, the start relays are underimpedance relays.

A full scheme relay has a measuring element for each measuring loop and for each zone. All measuring elements then does the measuring in parallel which this leads to shorter operating times.

The cost advantages with a switched scheme compared to a full scheme have been minimized with the introduction of numerical relays where all calculations are made by a processor.

The design of a numerical distance protection is shown in Figure 9. Input transformers provides the disturbance barrier and transforms the analogue signals into a suitable voltage, for the electronic circuits. Passive analogue filters prevents anti-aliasing. The analogue values for all voltages and currents are in an A/D converter transformed into digital values and are after a digital filtering sent in series to the measuring unit.

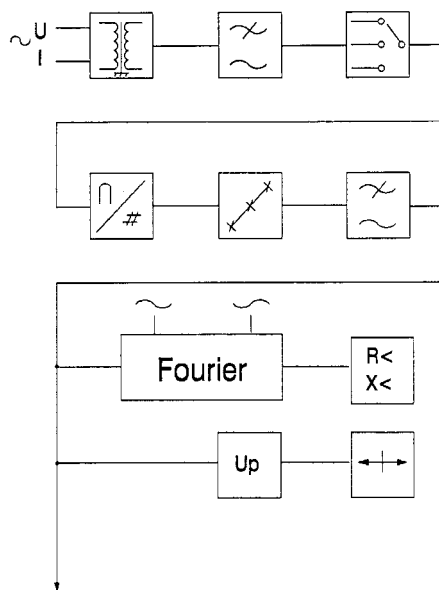

Figure 9. The design of a Numerical distance protection relay.

In the measuring unit a Fourier analyze and an impedance calculation are performed. A Directional check also is made. The directional check includes a positive sequence memory polarizing to secure correct function even with a completely collapsed voltage at a close-up fault.

## MEASURING PRINCIPLES

# Line protection

Impedance and direction criteria are checked in a logic and together with the time elements the full scheme protection relay is built up.

## Impedance measurement

The measure impedance at a certain fault position must not be dependent of the fault type. The correct voltages and currents must therefore be measured for each fault loop and the evaluation of loop impedance and the phase impedance to the fault must be done. The Distance protection relays settings are always based on the phase impedance to the fault. The measuring loops for different fault types are shown in figure 10.

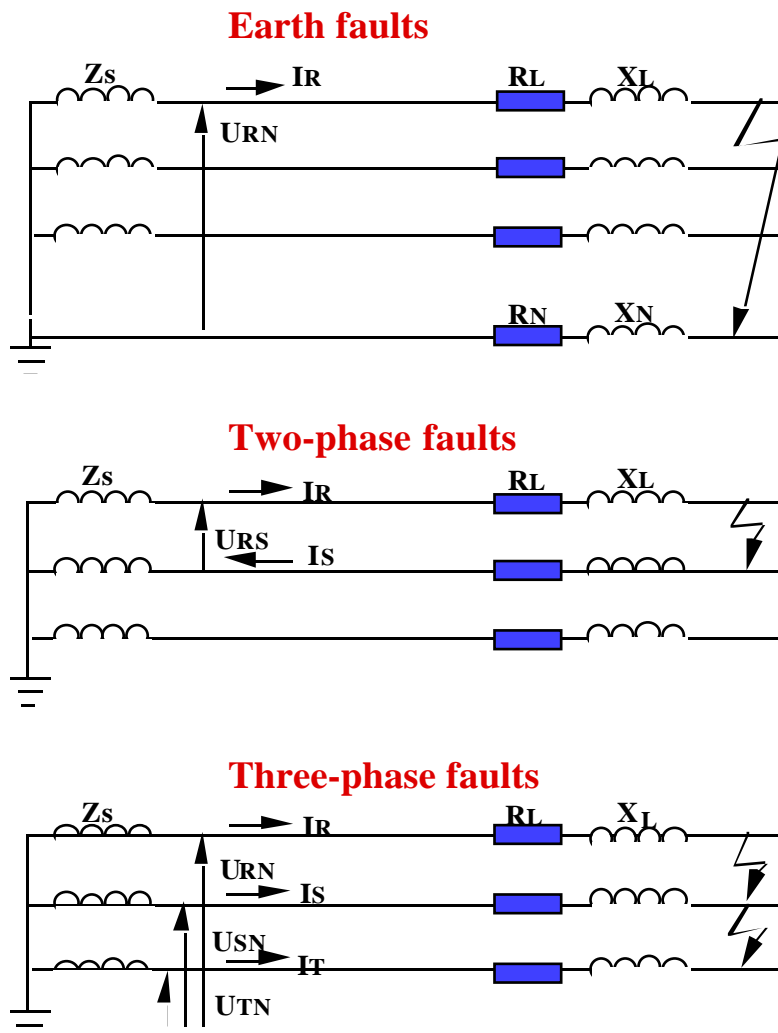

Figure 10. The impedance measuring loops for different fault types.

## MEASURING PRINCIPLES

For two and three phase faults the phase voltage and the difference between line currents are used. With this principle the measured impedance is equal to the positive sequence impedance at the fault location.

The earth fault measurement is more complicated. Using of phase currents and phase voltages gives an impedance as a function of the positive and the zero sequence impedance:

$$U = I_1 Z_1 + I_0 Z_0 + I_2 Z_2$$

$$Z_1 = Z_2$$

$$U = Z_1(I_0 + I_1 + I_2) + I_0 Z_0 - I_0 Z_1$$

$$I = I_0 + I_1 + I_2$$

$$U = I Z_1 + I_0 Z_1 \left( \frac{Z_0}{Z_1} - 1 \right)$$

$$U = I Z_1 + \frac{I_N}{3} Z_1 \left( \frac{Z_0}{Z_1} - 1 \right)$$

The current used is the phase current plus the neutral current times a factor  $K_N$ .

The zero sequence compensation factor is " $K_N$ " = " $(Z_0 - Z_1)/3Z_1$ ".

The factor " $K_N$ " is a transmission line constant and " $Z_0/Z_1$ " is presumed to be identical throughout the whole line length.

The total loop impedance for the earth fault loop can be described " $(1 + K_N)Z_1$ ".

### Measuring principle

Modern static Distance protection relays can be made with Amplitude- or Phase angle comparators. Both principles gives identical result.

An Amplitude comparison " $|I X Z_K| > |U|$ " gives in a R-X diagram a circular characteristic which is the simplest principle for a Dis-

---

## MEASURING PRINCIPLES

# Line protection

tance protection. " $Z_K$ " is the model impedance of the relay i.e. the set impedance. " $I$ " and " $U$ " are the measured voltages and currents. The relay will give operation when the measured impedance " $|Z| < |Z_K|$ ".

The same characteristic is achieved by comparing the signals " $I \times Z_K - U$ ", and " $I \times Z_K + U$ ", with operation for " $-\pi/2 < \theta < \pi/2$ ".

The comparators can be instantaneous, integrating or a combination of both.

The selected principle is decided by factors like circuit costs, speed requirements, immunity to disturbances etc.

Integration will make the relay slower but more resistant against disturbances. However, in modern numerical and static relays the immunity is achieved by an improved filtering technic. Instantaneous comparators can therefore be used with improved operating times as a result.

In numerical Distance protection relays the impedance is calculated for each measuring loop and is then compared with the set impedance.

Varying algorithms are used by different manufacturers dependent of the relay. In some new numerical relay of type **RELZ 100/REL 521** from ABB Network Partner, the impedance measurement is based on:

*The resistive component is calculated:*

$$R = \frac{UV \times DIH - UH \times DIV}{DIH \times IV - DIV \times IH}$$

*The reactive component is calculated:*

$$X = \omega \times dt \times \frac{UH \times IV - UV \times IH}{DIH \times IV - DIV \times IH}$$

---

## MEASURING PRINCIPLES

The values above are based on the voltage “**U**”, the current “**I**”, and the current change between the samples “**D<sub>I</sub>**”, sent through the Fourier filter. The Fourier filter creates two orthogonal values, each related to the loop impedance of each measuring loop.

$$U_H = R \times I_H + \frac{X}{\omega_0 \times dt} \times D_{IH}$$

$$U_V = R \times I_V + \frac{X}{\omega_0 \times dt} \times D_{IV}$$

Where “**H**” is the horizontal (active part), and “**V**” is the vertical (imaginary part).

**DIRECTIONAL MEASUREMENT** At fault close to the relay location the voltage can drop to a value, where directional measurement cannot be performed. Modern Distance protection relays will instead use a cross-polarization where the healthy voltage e. g. for a “**R**” fault the voltage “**U<sub>ST</sub> = U<sub>S</sub> - U<sub>T</sub>**” with a 90° phase shift compared to “**U<sub>RN</sub>**”. Different degrees of cross-polarization between the healthy and faulty phases exists in different products.

For three-phase faults the cross polarization does not enable measurement as all phases are low. A voltage memory circuit is then used to secure correct directional discrimination even at close-up faults with zero voltage in all three phases.

In new relays the memory is based on the positive sequence voltage. The memory is held for about 100 ms after the voltage drop. After 100 ms the most common principle is to seal-in the direction measured until the current disappears.

**INSTRUMENT TRANSFORMERS** The measurement of impedance and direction is done by signals from the current- and voltage transformers. Conventional current transformers may saturate due to the DC component in the short-circuit current. The best solution is to do the measurement before the CT-saturation. This requires a high speed performance of the relay.

---

## MEASURING PRINCIPLES

# Line protection

For distance measurement another solution is to measure the zero crossings. Even during a transient saturation of a CT core one zero crossing per cycle will be correctly reproduced.

CVT-transient is a big problem for the directional measurement in relays of Distance relay type. For these relays the CVT-transient has to be filtered out. The CVT transient is defined in IEC 186 and the transient voltage shall at a solid fault with zero voltage be  $<10\%$  after one cycle. It is obvious that quick operating relays will be much disturbed by a CVT transient.

If the change in voltage is used instead of the voltage itself, the problem can be completely avoided.

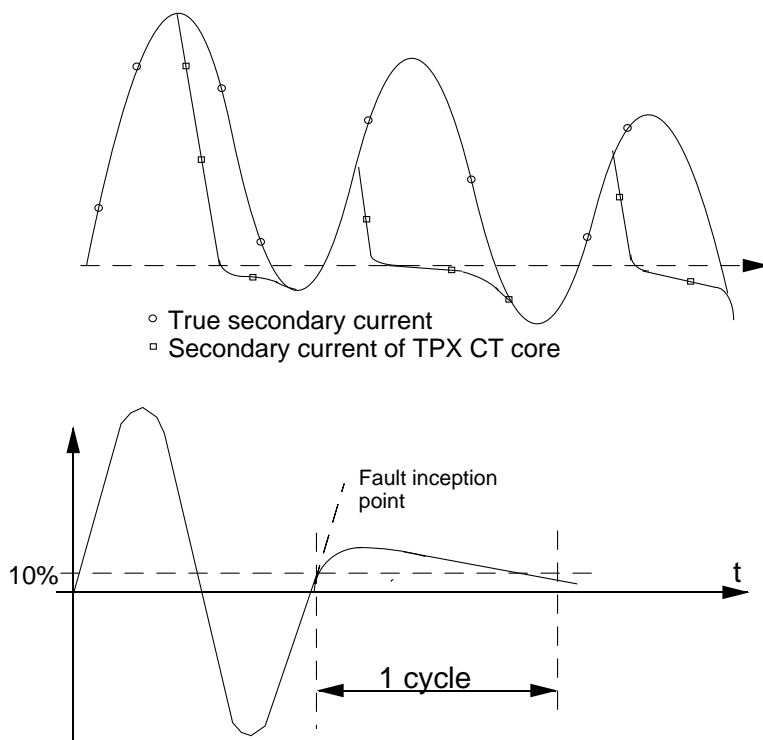

Figure 11. Output signals from a DC saturated current transformer and from a CVT at a close-up fault.

## Communication principle

In most Distance protection scheme applications, at least at voltages  $\geq 130\text{kV}$ , communication channels between the two ends are utilized to improve the protection system behavior.

The most common communication links are PLC equipment.

---

## MEASURING PRINCIPLES

## Communication schemes

The Distance protection relays can communicate in “Permissive” or “Blocking” schemes.

In *Permissive schemes* an acceleration signal “**CS**” is sent to the remote end, when the fault is detected “forward”. Tripping is achieved when the acceleration signal “**CS**” is received if the local relay has detected a forward fault as well.

Two main types of permissive schemes exist, see figure 12:

- 1) Underreaching schemes, where the acceleration signal is sent from a zone underreaching the remote end, usually zone 1, “**Z<sub>1</sub>**”.
- 2) Overreaching schemes, where the acceleration signals are sent from one overreaching zone, usually zone 1 “**Z<sub>1</sub>**” or zone 2 “**Z<sub>2</sub>**” overreaching the remote end. A directional start can also be used.

The overreaching schemes are normally used for short lines (<15 km) to improve the resistive coverage.

Receiving the carrier signal will, dependent of the selected scheme mean a time acceleration of Zone 1 (at Z1 overreach), or Zone 2 or Zone 3.



# Line protection

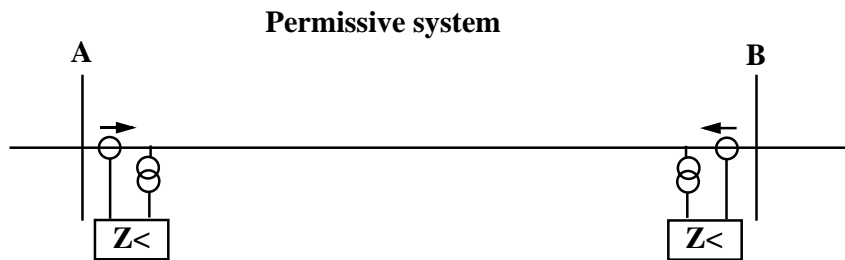

**Carrier send CS = Z< Forward, under or overreach**

**Trip = Z< Forward Z1, Z2 or Z3 & Carrier received**

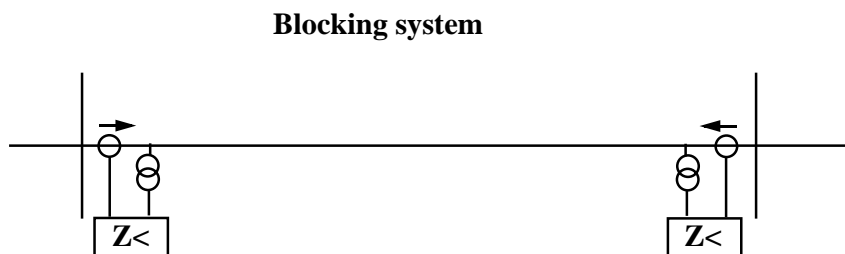

**Carrier send CS = Z< Reverse zone**

**Trip = Z< Forward Z1, Z2 or Z3 & Carrier received & T<sub>0</sub>**

*Figure 12. Communication with remote end, in Permissive schemes or Blocking schemes. CS from Underreaching zone or Overreaching zone.*

In *Blocking schemes* a blocking signal “**CS**”, is sent to the remote end when the fault is detected to be reverse. Tripping is achieved when the acceleration signal “**CS**” is not received within a time of **T<sub>0</sub>** and if the local relay has detected a forward fault as well. A time margin **T<sub>0</sub>** of 20-40ms to check if the signal is received is always needed in a blocking scheme.

The accelerated tripping after “**T<sub>0</sub>**” are from “**Z<sub>2</sub>**” or “**Z<sub>3</sub>**”.

If different types, or manufacturer, of Distance protection relays are used at the two line ends blocking schemes should be used only after checking that the relays will operate together. A relay

---

## MEASURING PRINCIPLES

where a blocking signal is sent for “start” but not “forward” should, as a general principle, never be used together with a relay with a true reverse directional element sending the blocking signal.

The using of Permissive schemes or Blocking schemes in the system depends on the preference for Security or Dependability. A Blocking scheme will be Dependable, i. e. it will operate for an internal fault also with a failing communication link, but it has a lower security as it can maloperate for an external fault due to a failing communication link. The Permissive scheme has the opposite behavior. The advantage with the blocking scheme is that communication signals are sent on healthy lines whereas on permissive scheme the communication signals are sent over a faulty line.

### **Reasons for incorrect impedance measurement**

To enable a correct impedance measurement the measured voltage must be a function of only the locally measured current “ $I_A$ ” and the impedance at the fault. This is naturally not always the case in double-end infeed and meshed transmission networks.

**REMOTE FAULTS** If a fault occurs on an outgoing line in the remote substation where the own line will feed fault current “ $I_{f1}$ ”, see fig 13, the other lines in the remote station will also contribute with the fault currents “ $I_{f2}$ ” and “ $I_{f3}$ ”. The measured impedance at the local station will then be as in the figure and the measured impedance at the fault will seem much higher than the “true” impedance to the fault. The relays will thus get an apparent underreach. This means that, in practice the possibility to get a “remote back-up” in a transmission network is limited. A local back-up must therefor normally be provided.

# Line protection

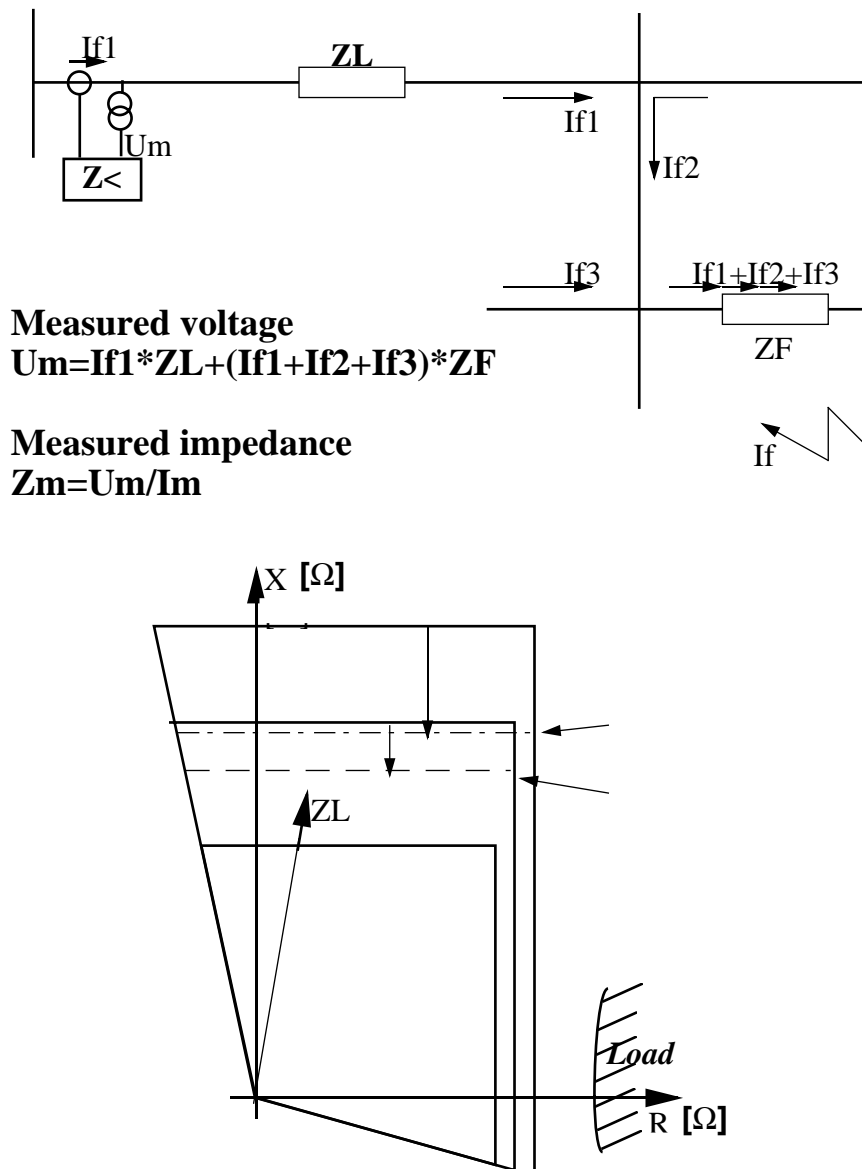

Figure 13. The Distance protection underreach at a remote fault.

At high resistive line faults on a transmission line with double-end infeed a similar situation will occur. In normal service a load current “ $I_b$ ” flows through the line.

The current level is expressed:

$$I_b = \frac{|E_A - E_B|}{Z_L}$$

---

## MEASURING PRINCIPLES

“ $U_A$ ” and “ $U_B$ ” must have a phase difference to allow the current to flow. This, if the voltage amplitude is the same, which is a “normal case” in the transmission network. When a fault occurs, the currents “ $I_A$ ” and “ $I_B$ ”, are lagging “ $E_A$ ” respectively “ $E_B$ ”, and have therefor also a phase difference compared to each other. The resistance “ $R$ ” at the fault will be seen as a resistance plus a reactance reduction (at export) and a reactance addition (at import).

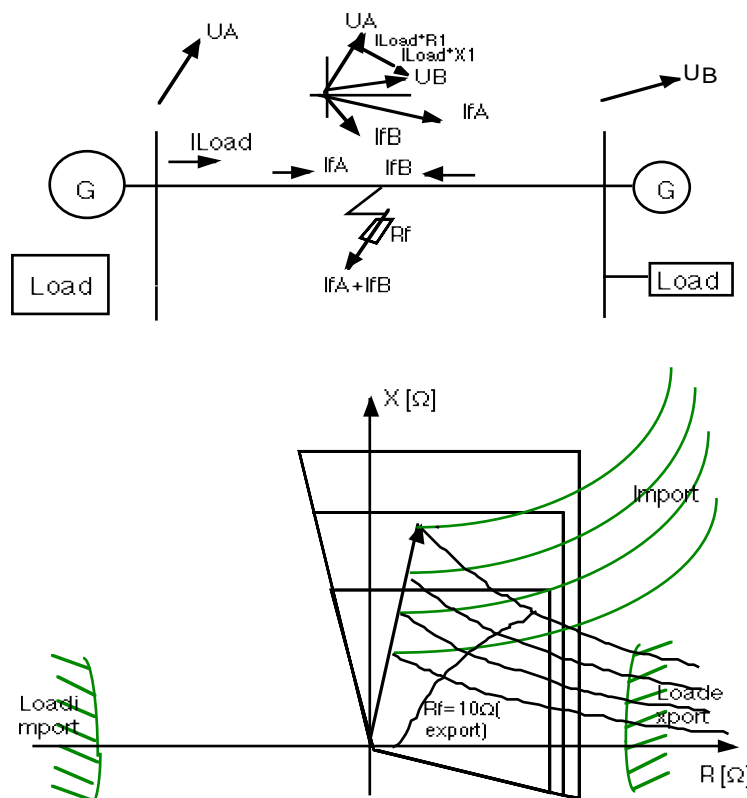

Figure 14. Measuring error at a high resistive earth fault in a line with double side infeed.

The measuring error will be:

$$\frac{I_A}{-I_B} R_f \sin \Theta$$

$$\frac{-I_B}{I_A} R_f \sin \Theta$$

At the two line ends (see fig), “ $\Theta$ ” is the phase angle difference between “ $A$ ” and “ $B$ ” stations. The exporting end will thus over-reach i. e. a fault at the line end can be seen as an internal fault,

## MEASURING PRINCIPLES

# Line protection

and the import end will underreach i. e. a fault will seem further off than it is in reality.

If the power direction always is the same a compensation can be made when setting the relays. The earth fault loop setting must especially be considered as the high resistive faults normally only occur at earth faults only.

**PARALLEL POWER LINES** When parallel lines at the same tower are used there will be a mutual impedance, normally only of interest when an earth fault occurs. Normal values of the mutual impedance at earth faults for transmission line towers are “ $Z_m$ ” = “0,5-0,6x $Z_0$ ”.

The mutual impedance will for earth faults mean over- respectively underreach for the two line ends. The over- or underreach is dependent on the fault position and the zero sequence sources at the two line ends. The level of overreach resp underreach in the measurement is in the range up to 16%.

Different situations will occur when:

- Parallel lines are in service.
- Parallel lines are out of service and earthed.
- Parallel lines are out of service (floating).

Compensation have to be done for the different cases when setting the relay earth fault reach. The “ $K_N$ ” factor is adjusted to achieve a suitable setting. Normally the worst case is selected and the “ $K_N$ ” is set to prevent overreaching, and thus unnecessary operation. The overreach is caused by the parallel line out of service and earthed at both ends and the factor  $K_N$  should be set as:

$$K_N = \frac{X_0^2 - X_{m0}^2 - X_0 X_1}{3X_0 X_1}$$

---

## MEASURING PRINCIPLES

When the parallel line is out of service but ungrounded the reach will be reduced with a factor  $k_1$ . This factor should be checked and the overlapping of zone 1 from both end at underreaching schemes should be verified.

$$k_1 = \frac{(1 + K_{N1}) 3X_1}{2X_1 + X_0}$$

The setting of  $K_N$  factor for zones 2 and up should always be as the normal setting with an extended factor of 1,25 to cover a worst case which occurs when no fault current is fed in at the remote terminal.

Note that the change of reach for parallel lines with compensated  $K_N$  is only valid for single phase faults. For multi phase faults the reaches are not influenced.

Figure 15 shows the principle of the mutual impedance.

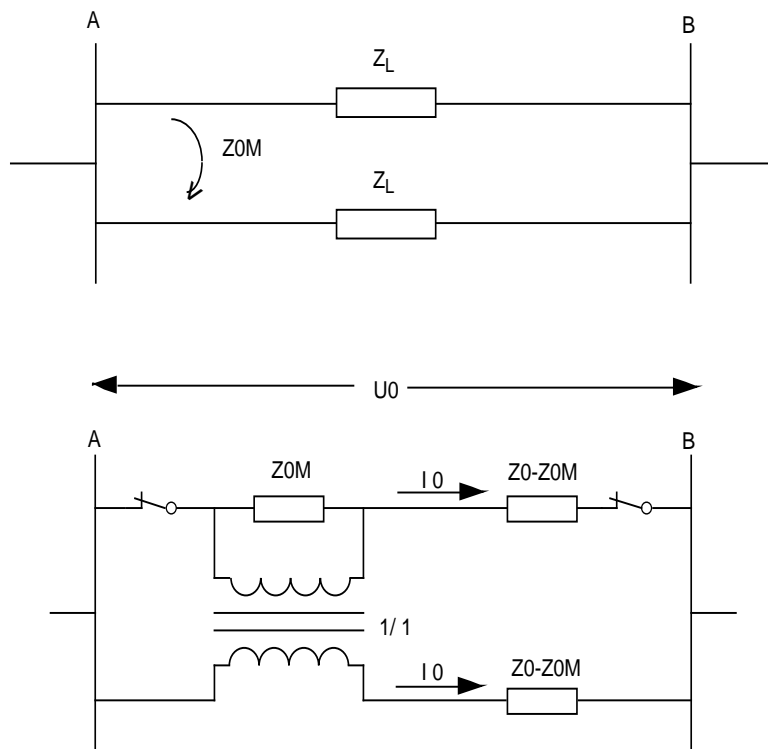

Figure 15. Influence of mutual impedance, at parallel lines, at the same tower.

# Line protection

## Special functions

Some special functions are of interest with Distance protection relays and should be mentioned.

**SWITCH ONTO FAULT (SOTF)** At energizing a power line onto a forgotten earthing, portable or fixed, no measuring voltage will be available and the directional measuring can thus for three phase faults not operate correctly. A special SOTF function is thus provided in Distance protection relays. Different principles can be utilized, from an one phase current/one low voltage measurement to an undirectional impedance measuring as per figure 16. The SOTF function is connected for some second/s only when energizing. The criteria that there is a SOTF condition can either be taken from the manual closing signal (called DC SOTF) activating an input in the relay, or can be detected internally by the relay (AC SOTF) where a no voltage-no current condition for a certain time is taken as confirmation that the line is dead.

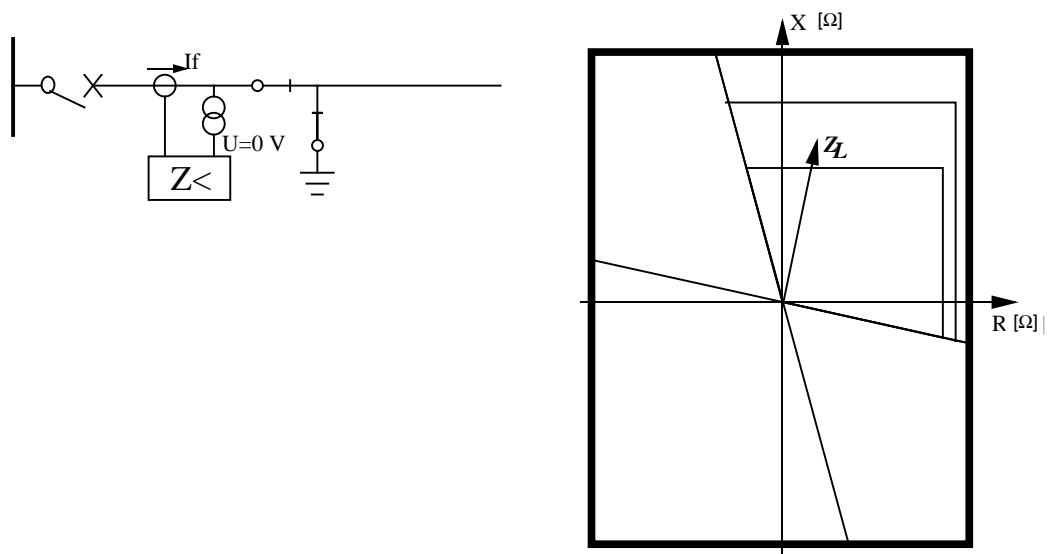

Figure 16. Switch Onto Fault function ensures fast tripping when energizing a line onto a forgotten earthing.

## POWER SWING BLOCKING (PSB) FUNCTION

Power swings can occur at double end in-feed networks. A Power swing can be started by a sudden load change, due to e. g. manual switching, or at a fault somewhere in the network.

Close to the centre of the power swing low voltages and thus low impedances will occur. A Distance protection relay can thus operate at a power swing and this is in most countries not accepted. A Power Swing Blocking device is available for all schemes. The most used principle used is to “measure the speed of the impedance locus”. This is done by two impedance circles, or rectangles, and a measuring of the time between passing the outer and the inner line. Normally the time used is 35-40ms.

Exceeded time will make an alarm telling that a Power swing has occurred. A blocking of the Distance protection zones will then be made. Normal power swings in networks have a swing cycle of 0.5-10 seconds.

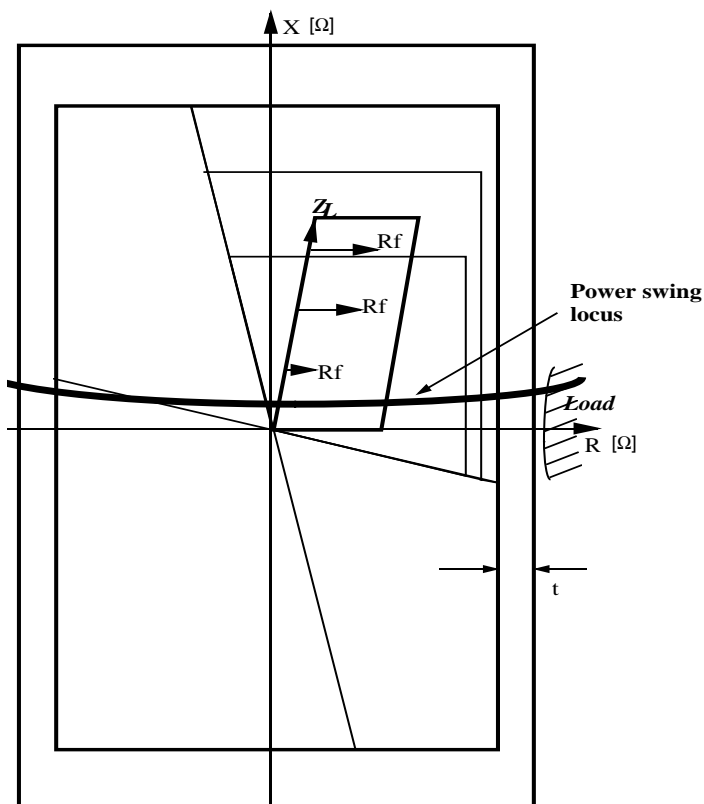

Figure 17. Power Swing Blocking function. Two rectangles can be provided and the time between passing the outer and inner rectangle is measured.

STUB PROTECTION FUNCTION In one and a half and ring busbar arrangements the voltage transformer will be located outside the

## MEASURING PRINCIPLES



# Line protection

line disconnector but the bays can be in full service with the breaker closed even if the line disconnector is opened e. g. due to make maintenance on the power line.

A fault in the line bay section, will not be possible to detect by the distance protection. It's also a risk of incorrect directional measurements due to induced voltages or back-feed of voltage from the remote end. The Distance protection directional impedance measuring is blocked and a so called Stub protection is introduced. The Stub protection is a simple current relay activated only when line disconnector is open.

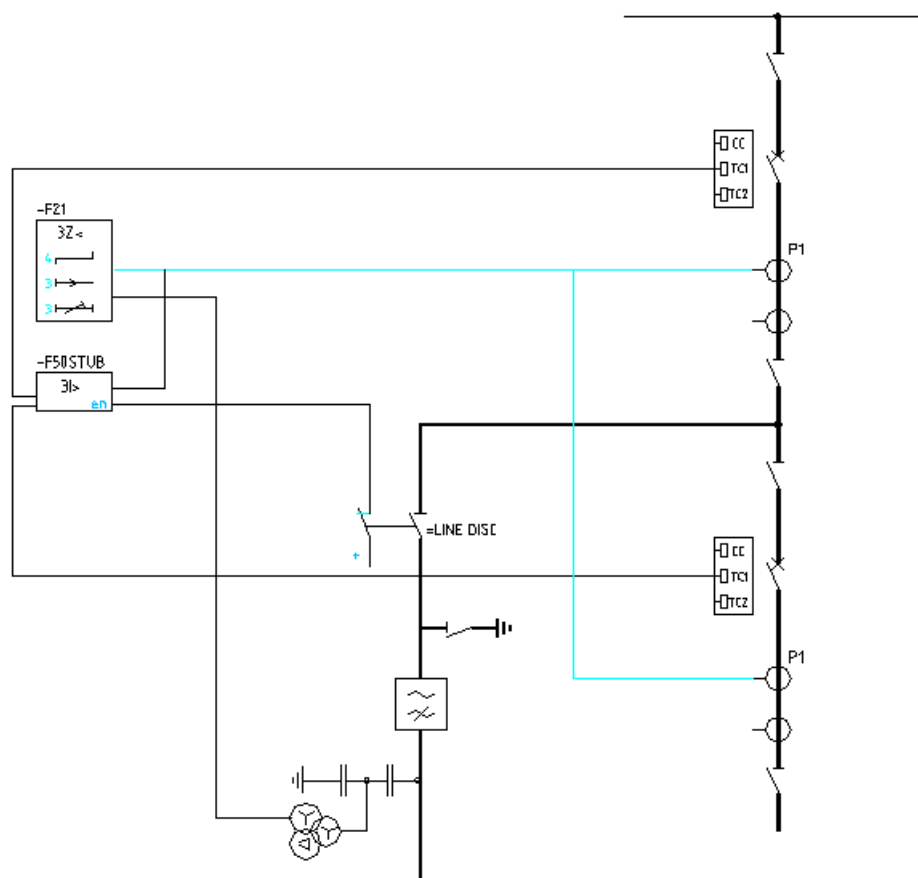

Figure 18. Stub protection function protects the line exit when the line disconnector is open.

### 3.4 APPLICATION PROBLEMS

A number of interesting application problems occurs in a transmission line. Among them should be mentioned: Current reversal  
 In the quite common “parallel line applications” current reversal can occur. The principal problem is shown in figure 17 and an example of the logic used to ensure correct operation is shown in figure 18

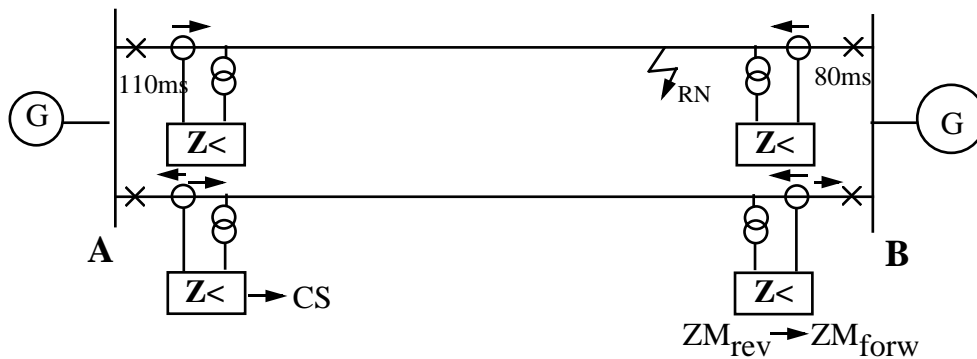

Figure 19. Fault current reversal occurring, with parallel lines, at the same tower.

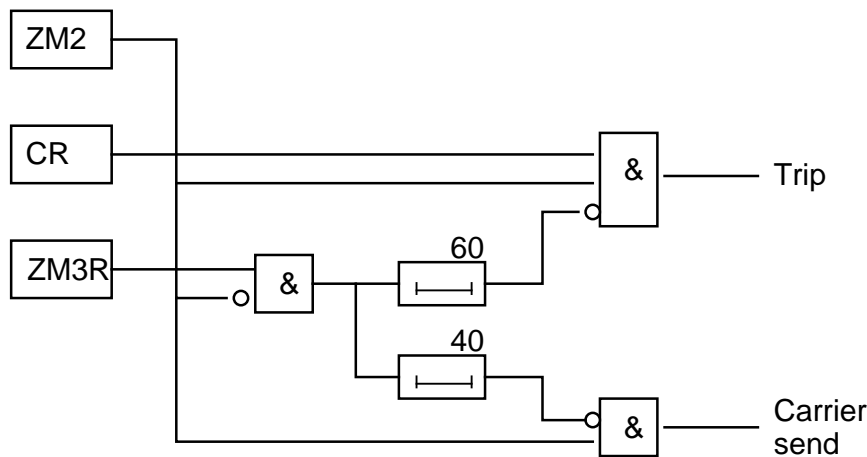

Figure 20. Fault current reversal logic for overreaching scheme in RELZ 100/REL 511/521./531 “ZM2” is measuring zone 2, “ZM3R” is Zone 3 reverse and “CR” is carrier receive.

When a fault occurs at a line, on a parallel connection, the fault will always be cleared from one line end first. When the first breaker opens, the fault current in the parallel line will have a change of direction and if nothing is done in the logic for communication, maloperation can occur on the parallel healthy line. It should be noted that the problem occurs for overreaching schemes only.

---

#### MEASURING PRINCIPLES

# Line protection

**SIMULTANEOUS FAULTS** In the quite common “parallel line applications” simultaneous faults can occur. A fault can occur between “L1” and “L2” but the phases are at different lines. A full scheme relay is a must to give correct operation for simultaneous faults as the measuring loops for earth faults must detect one forward- and one reverse fault in different phases and a logic must be provided in the relay to get the correct operation. Many Distance protection relays (even of new types), will risk maloperation at these faults and care must also be taken when the relay zones and the phase selection are set.

Switched schemes can due to the starter function not operate correctly for simultaneous faults. The starter will select both involved phases to the measuring element on both involved lines distance protection relay. The measurement will then naturally be incorrect.

Figure 21 shows the principle for simultaneous faults. The new Distance protection relays from ABB Network Partner provides a logic to cover the problem.

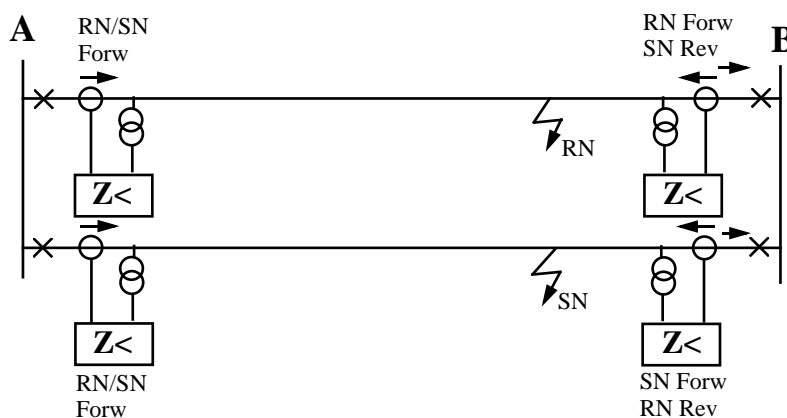

Figure 21. Simultaneous faults, in parallel lines, at the same tower.

**SERIES CAPACITORS** The use of forward impedance measurement using the reactive characteristic of the transmission lines, implies that Distance protection relays can't be used in series compensated lines without special care. Experts must be consulted for such applications. This is also valid for surrounding lines in the same station.

---

## MEASURING PRINCIPLES

## 3.5 TRAVELLING WAVE PROTECTION RELAYS

The travelling wave detector, was a revolution in relay technology, when first developed at the end of the seventies.

A fault in the power network, moves with the speed of light and causes changes in the transmission network.

By detection of the transient changes in the current " $\Delta i$ ", and in the voltage " $\Delta u$ ", and by comparing the signs of the two, the direction to the fault can be determined. The fault detection can be done very quickly. In the total trip time the communication time for the communication with the remote end also must be included as the protection forms a directional comparison scheme.

The travelling wave protection schemes are only used in EHV networks and are very suitable to be used in series compensated lines where a distance protection scheme has a draw-back.

Due to the rather limited use for EHV lines the protection will not be discussed further in this document.

## 4. AUTO RECLOSING

### 4.1 THE PRINCIPLE OF AN AUTO RECLOSING DEVICE

For restoration of the normal service after a line fault an Auto reclosing attempt is mostly made for Overhead lines. From fault statistics it has become accepted that as high as 95% of the faults are of transient nature i.e. an Auto reclosing can be successful.

The three phase quick Auto reclosing attempt is mostly carried out after a synchro check where the voltages on both sides of the circuit breaker are checked and it is verified that they are not out of phase due to e. g. a heavy power swing.

---

#### AUTO RECLOSING

# Line protection

For single phase Auto reclosing an identification of the faulty phase is necessary. This phase selection can not be achieved at high resistive earth fault, when " $R_F > 50-200 \Omega$ ". Faults with higher " $R_F$ " can be detected by zero sequence current protections but can't be single phase Auto-reclosed as the discrimination of the faulty phase is difficult. Special schemes have however been developed for cases where there is a definite need to disconnect only one phase due to a very weak network.

## 4.2 GENERAL CONDITIONS FOR AUTO RECLOSING

The Auto reclosing shall be coordinated with various equipment as indicated in Figure 22.

- AR - Auto-recloser
- BFR - Breaker failure relay
- COM - Communication
- COND - CB condition
- DLC SC - Dead line check and synchronism check
- LP - Line protection
- MAN - Manual CB control
- PD - Pole discordance relay

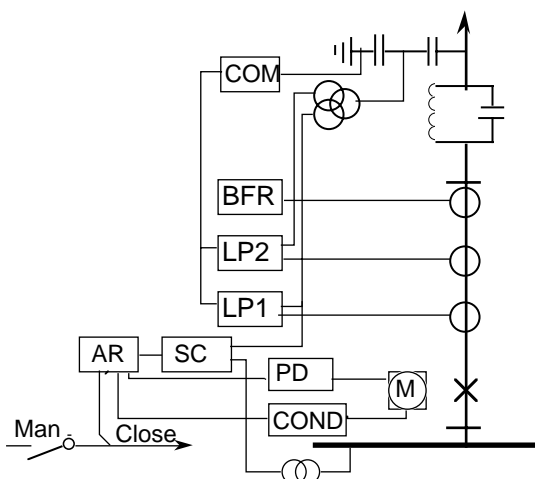

Figure 22. The Auto recloser and communicating equipment in a line bay.

### Line protection relays.

There may be a single distance relay or duplicated protection. A delayed back-up function is normally included. The Auto recloser

---

## AUTO RECLOSING

is started at relay tripping. At delayed tripping the recloser is normally blocked.

### **Communication.**

Communication between the line relays is used to ensure quick and simultaneous tripping at both ends. With relay cooperation in the permissive mode there is a risk for delayed tripping at one end if the communication is not working when a line fault occurs. Dead time at quick Auto reclosing must be increased or recloser start should be blocked at loss of communication.

### **Circuit breaker operating gear.**

Energy is stored for close and trip operations. If there is insufficient energy stored for a close-trip sequence, recloser start shall be prevented.

Circuit breaker failure relays. Circuit-breaker trouble detected by breaker failure relay or pole discordance relay should block Auto reclosing.

### **Dead-line check and synchronism check.**

Depending on the power grid configuration it may be necessary to use a synchro-check relay to prevent Auto reclosing at loss of synchronism. Dead line check is then made at one line end and synchronism check at the other. In power grids with several reliable parallel circuits high-speed Auto reclosing is, however, often arranged to work without any synchro-check function.

### **Manual CB operation.**

At manual CB closing the recloser is blocked. Should there be a fault on the line it is then tripped but not reclosed. At manual CB tripping the recloser is not started.

### **Status of recloser.**

The recloser status shall influence the tripping. In the recloser for single-pole or three-pole reclosing there is a programming for selection of reclosing mode. If the program is set to the position for three-phase reclosing or reclosing off, or the recloser is blocked by external conditions, all trippings shall be made as three-pole operations. Sometimes, when investment in communication between distance relays is not made, the relays are set with a zone 1 overreach and thus cover more than the whole line at the first

---

## **AUTO RECLOSING**

# Line protection

tripping. At reclosing the zone 1 reach is shortened to ensure selective clearance of persistent faults. When the recloser is blocked or switched off, the zone 1 reach shall also be reduced to give selective fault clearance already at the first tripping.

## The principle for an Auto reclose cycle

The principle of an auto reclosing cycle is shown in figure 23.

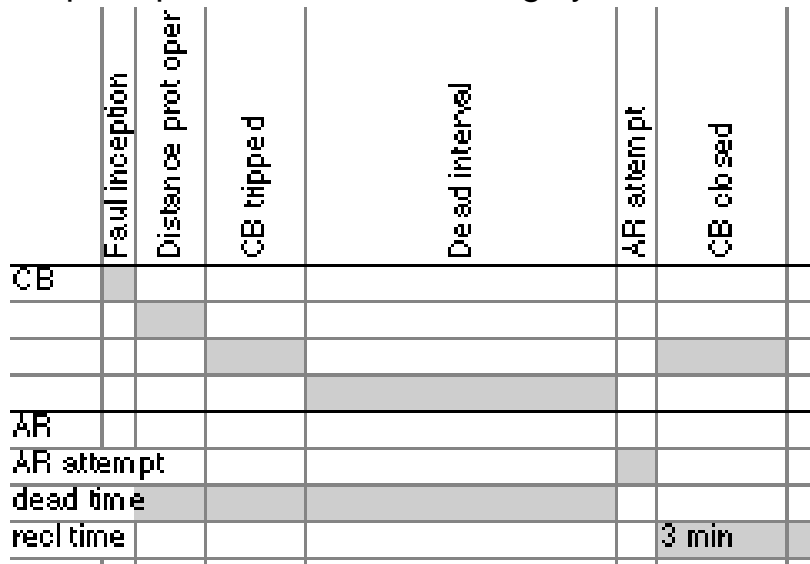

Figure 23. The operating principle of an Auto reclosing device.

The Auto reclosing device is providing a reclosing attempt, after a dead interval with sufficient length, to ensure that deionisation of the fault area has taken place. The dead, and blocking time must match the breaker capability. Normally the circuit breakers fulfil the IEC duty cycle for circuit breakers O - 0.3 seconds CO - 3 min CO

**FAULT TIMES AND DEIONISATION** The time to achieve deionisation after the fault is dependent of several factors such as time to fault clearance, fault current, wind, air humidity, capacitive coupling to live parts etc.

The dead interval must be selected to give sufficient time, to deionise the fault area. For instantaneously cleared faults (<100ms), a dead time of 300-400ms can be sufficient.

---

## AUTO RECLOSING

If the fault clearance is delayed, say fault clearance times of 0.5-1 second, the dead interval must be longer e.g. 1 second.

When single phase Auto reclosing is used the dead time must also be longer. Normally times of 0.8-1.2 seconds are used. The reason for this is the capacitive coupling to live phases which will maintain the arc. For long lines (>150km) it may even be necessary to introduce a neutral reactor to the line (teaser reactor). The teaser reactor shall have an inductance matching the line capacitive reactance to enable single phase auto reclose with reasonable long dead time.

### **Auto reclosing schemes**

There is a number of different practices, the most common ones are:

- Three phase auto-reclosing at all type of faults.
- Three phase auto-reclosing only at single phase faults.
- Single phase auto-reclosing at single phase faults together with three phase auto-reclosing at multi phase faults.
- Single phase auto-reclosing at single phase faults only.

Three types of dead interval are used:

- Quick Auto reclosing, with a dead interval less than 0.8 seconds. A quick Auto reclosing requires communication between the line ends and an instantaneous fault clearance at both ends.
- Quick auto-reclosing with a dead interval longer than 0.8-2 seconds can be used when no communication exist and the fault clearance will or can be made from the Distance protection second zone at one of the line ends. The dead interval must then be increased.
- Delayed auto-reclosing, with a dead interval from 6 seconds up to several minutes is mostly used in distribution networks but are also used at transmission voltages in some countries.

## **4.3 BLOCKING**

The Auto recloser must be blocked under the following conditions:

---

### **AUTO RECLOSING**



# Line protection

- Energizing of a line onto a fault. When a line is closed onto a fault the Auto recloser is blocked to prevent unnecessary disturbances in the power network. The chance of a persistent fault is high as the line has not been carrying load and is therefore not a part of “normal conditions”.
- Auto-reclosing onto a persistent fault. An unsuccessful auto reclosing means that the fault probably is persistent. The auto-recloser is then blocked to prevent new attempts. Solutions with several attempts however exist but the breaker duty cycle must then be carefully checked.
- “Breaker not ready” is used to block the auto-recloser. The breaker is then not ready to perform any attempt and the breaker can not be automatically reclosed.
- PLC (or communication channel) out of service must be connected to block the Auto recloser if a quick auto reclose attempt is used. The fault has not surely been cleared from the remote end and an auto reclose might therefore not be successful.

## **5. AUTO RECLOSE FOR ONE-AND A HALF BREAKER OR RING BUSBAR SCHEMES.**

Auto reclosing of transmission line circuit-breakers is somewhat more complicated in One- and a half breaker, 2-breaker and Ring busbar stations than in simpler stations with a One line - One breaker arrangement. At a line fault two CB's shall be tripped and reclosed at each end of the line and some coordination is required. In addition one circuit breaker (tie breaker) is shared by two circuits in One- and a half breaker and Ring busbar stations. A standardized Auto reclosing scheme designed by ABB combines flexibility with some particular features:

- High-speed or delayed Auto reclosing.
- Single-pole an/or three-pole Auto reclosing with independent setting of dead times.
- Synchronism check feature as an option. It can be combined with delayed or high-speed three pole Auto reclosing.
- Cooperation with single- or duplicate line relays.
- Adapted to communicating line relays or Distance relays with overreach of zone 1 before Auto reclosing.

---

### AUTO RECLOSE FOR ONE-AND A HALF BREAKER OR

- Suitable for various station arrangements including One- and a half breaker and ring busbar stations. The two line CB:s in a station can be reclosed successively with a priority circuit.
- Only those CB:s which were closed before the line fault are reclosed.
- The dead line time is not influenced if one of the two line CB:s in a station is out of service when the fault occurs.
- Correct behavior also for interline faults when parallel lines are used.

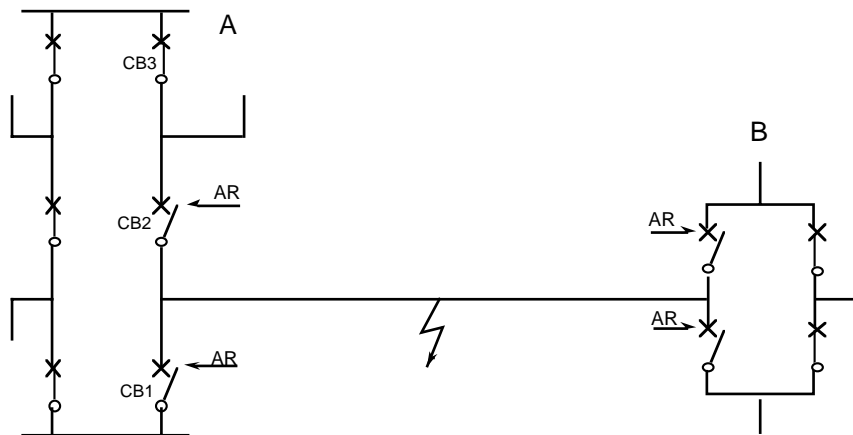

Figure 24. Auto reclosing of transmission line CB:s.

---

## AUTO RECLOSE FOR ONE-AND A HALF BREAKER OR

# Line protection

## **INFLUENCE OF THE STATION ARRANGEMENT ON THE AUTO RECLOSING**

The type of switchgear arrangement will influence the introduction of Auto recloser and Synchro check devices. A number of possible different arrangements are shown in below figure.

---

AUTO RECLOSE FOR ONE-AND A HALF BREAKER OR

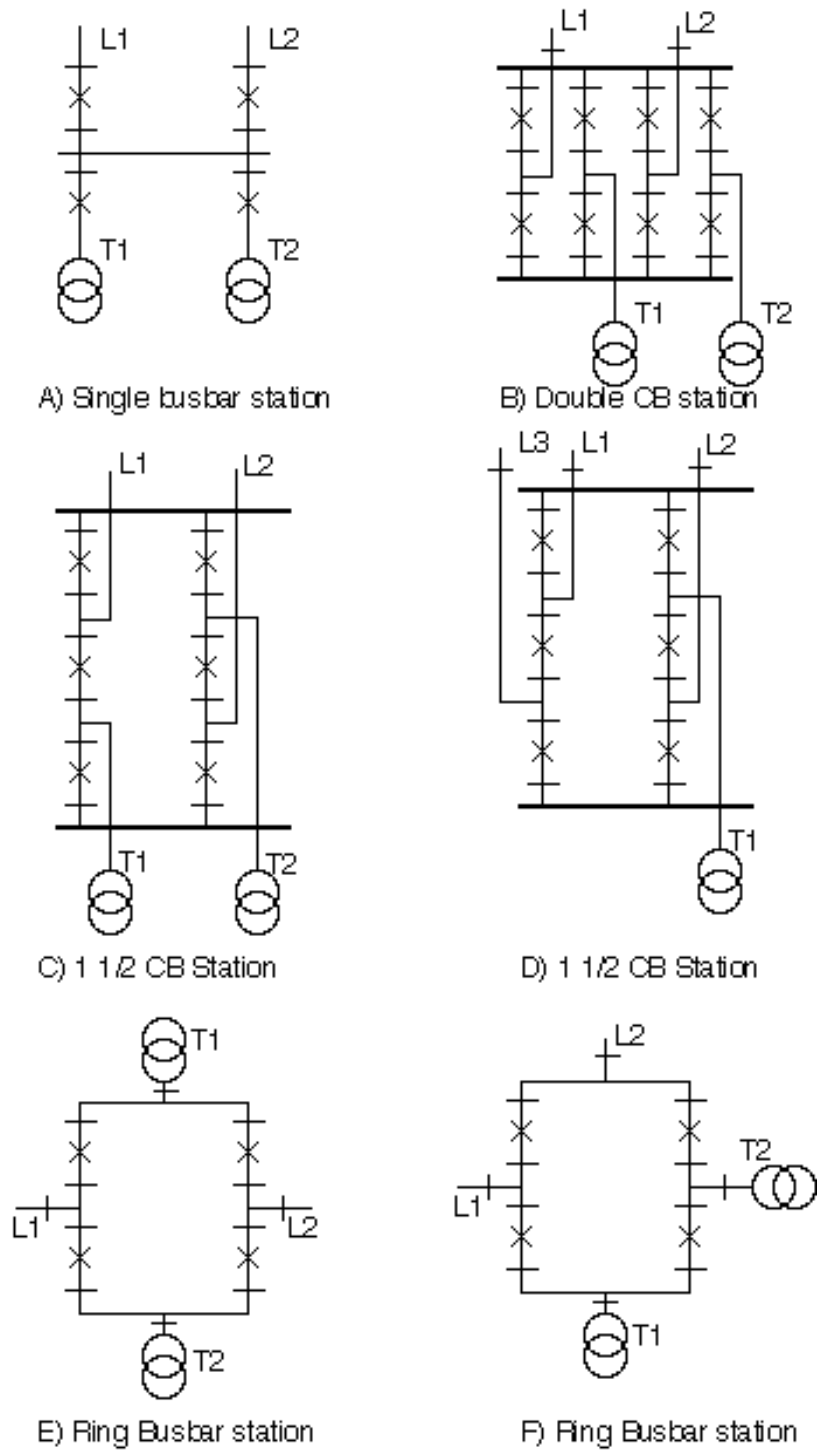

Figure 25. Examples of multi breaker switchgear arrangements

## MULTI BREAKER ARRANGEMENT

Application of Auto reclosing in an One- and a half breaker, Two-breaker or a ring busbar station requires some particular attention. After a line fault two CB's at each end of the line shall be reclosed and need to be coordinated. One CB can be taken out of

---

### AUTO RECLOSE FOR ONE-AND A HALF BREAKER OR

# Line protection

service independently of the line and that CB shall in such a case not be Auto-reclosed if a line fault occurs.

In a One- and a half-CB station each centre CB is shared by two circuits, for instance a line and a transformer as in Fig. 25c, or two lines as in Fig. 25d. In a ring busbar station all CB's serve two circuits in the same way. Interconnecting circuits are necessary between the line oriented equipment, CB equipment and Auto recloser. It is important to arrange these circuits in a manner that the correct and reliable function is obtained and that the arrangement can be simple understood, checked and maintained. A standard scheme with options for different requirements is thus preferable.

Following special problems should be considered.

## Priority circuit.

When one line is controlled by two circuit breaker both must be opened when a fault occurs and should consequently also be reclosed. To limit the consequences if the fault is persistent the two breakers are reclosed in sequence and a priority circuit is built-up to manage the priority. The common way is to reclose the bus breaker first in a one- and a half breaker scheme. In other arrangements one CB must be given the higher priority.

The priority circuit is based on the start of the AR devices where the start of the highest priority CB AR device puts the low priority CB AR on a "wait" condition until the first CB has successfully reclosed and the AR device has reset. The dead time for the second CB is then started and the second CB reclosed. The advantage is that the low priority CB need not to be stressed if the fault is persistent.

Should the first breaker fail to reclose due to a persistent fault a circuit is arranged to reset the second recloser also when the new trip is achieved.

---

## AUTO RECLOSE FOR ONE-AND A HALF BREAKER OR

### AR out of service.

Of course the circuit breaker shall not be single phase trip is the Auto recloser is in “OFF” position, in the “3 phase” position or out of service due to e. g. AR device Auxiliary voltage supply failure. CB not ready should also be included in this circuit. It is then essential that a prepare three phase trip circuit is designed and for multi breaker schemes this must be done on the trip unit for each circuit breaker as the choice can be made independently for each breaker. It must be remembered to use a fail safe connection independent of the voltage supply of the AR device. The circuit is shown in below figure. The circuit must include preparation of three phase tripping in both of the redundant trip systems. Principles for exchange of information between sub systems should then be considered, see a separate section in this book.

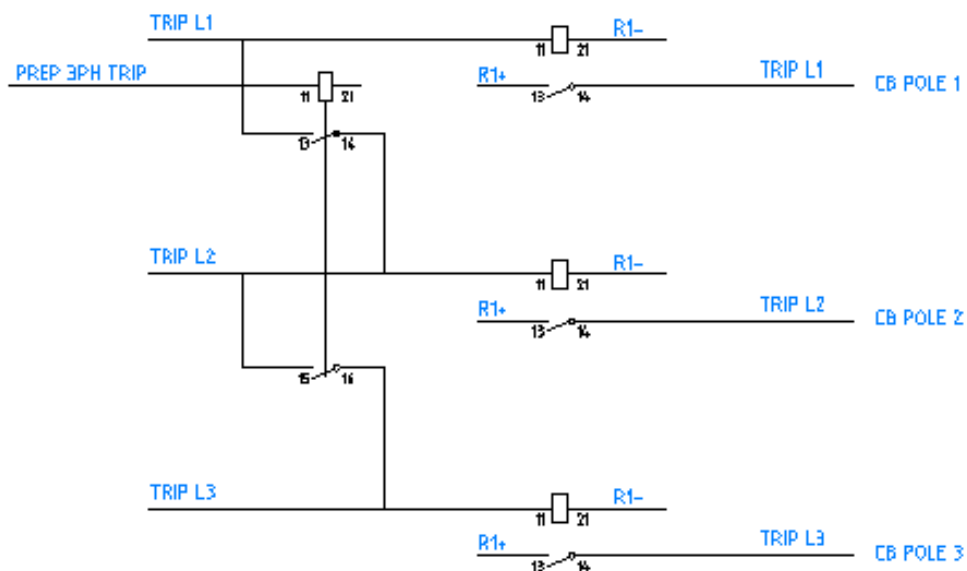

Figure 26. The principle circuit for arrangement of prepare three phase trip at a multi breaker arrangement.

---

## AUTO RECLOSE FOR ONE-AND A HALF BREAKER OR

# Line protection

In Fig. 27 some examples are illustrated. In the following, Auto reclosing of a line in an One- and a half-breaker bay for two lines will be used as an example. It is a representative complicated case.

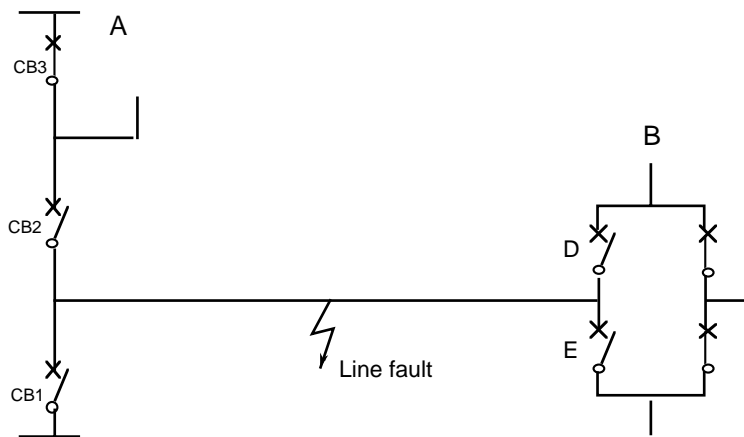

Figure 27. Some Auto reclosing sequences in multi breaker systems.

## 5.1 AN AUTO RECLOSING SCHEME

An Auto reclosing scheme in a multi breaker bay can include:

- One Auto recloser for each line CB.
- Coordination between auto-reclosers.
- Dead line/synchro-check circuits and relays for CB conditions and interconnection with CB pole discordance relay.
- Adaptation of the trip relay circuits.
- Interconnection and interfacing with line protection relays and communication equipment.

The equipment in a bay of a One- and a half-breaker station is shown in Fig. 28 and in Appendix 3.

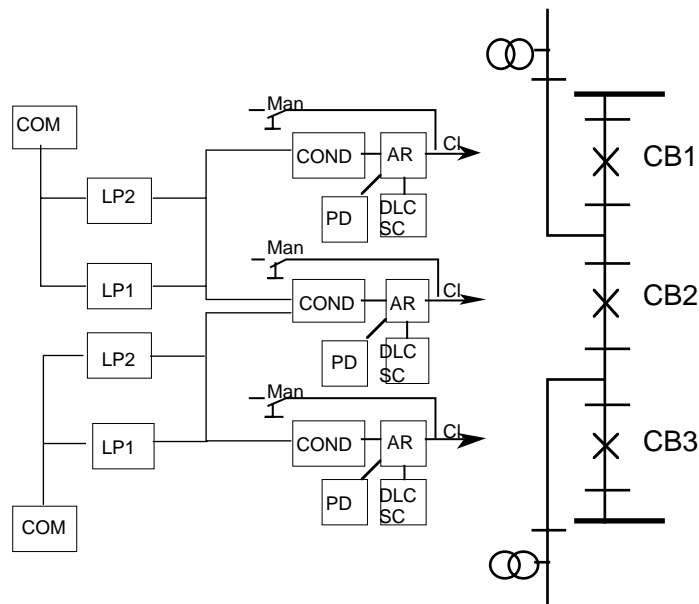

Figure 28. Auto-reclosers (AR) and cooperating equipment in a One- and a half-breaker bay

The line protection relays are normally Distance protection relays which are designed to cooperate with the auto-reclosers.

Duplicate, redundant Distance relays are often used for important transmission lines. The reclosers must thus cooperate with two such protection systems.

The auxiliary supply circuits are essential for the reliability. The Auto reclosing scheme can be combined with duplicate DC systems. The primary protection relays, the Auto-reclosers, the synchro-check relays etc. are then supplied from one DC-system. The secondary redundant protection relays and trip circuits are connected to the second DC system.

Each CB has an independent Auto recloser so each line protection has cooperation with two Auto reclosers and the line can be Auto-reclosed even if one CB or one recloser is out of service or switched off when the fault occurs.

In order to gain maximum flexibility the auxiliary DC sub-distribution is normally made with individual fusing (by MCB or fuses) for each CB section and each line. The auxiliary supply can thus be switched off when maintenance is made on one CB or on the line equipment.

Auxiliary and time-lag relays are used for various purposes, tripping, interfacing, galvanic separation etc.

## AUTO RECLOSE FOR ONE-AND A HALF BREAKER OR



## 5.2 AUTO RECLOSING SEQUENCES.

Some Auto reclosing sequences obtained by use of ABB standardized Auto reclosing scheme in a One- and a half-breaker bay are described below. The arrangement is shown in **Appendix 3**.

### Assumptions:

All CB's and disconnectors are closed. The lines are in normal service. All protection relays with power line carrier (PLC) communication are in operation.

The reclosers are set for 1- and/or 3-pole tripping and Auto reclosing. The dead times are 1.0 and 0.4 seconds respectively.

CB 1 shall reclose before CB 2. CB1 is selected to energize the line and the Voltage check VC is released. CB 2 is selected to Synchro check SC and no VC is allowed.

The line shall be reenergized from this station with CB 1 as first priority.

### **A Three-pole Auto reclosing with VC resp. SC**

#### Approximate time plan.

0.0 s A multi-phase fault occurs on line 1. The line relays operate instantaneously and the trip relays in all three phases operate.

The conditions for auto-recloser start are fulfilled. The reclosers for CB 1 and CB 2 are started for a three-pole reclosing.

The priority circuit from the CB 1 recloser keeps the CB 2 recloser waiting.

CB 1 and CB 2 and remote end CB's clear the fault. The line relays and the trip relays resets.

0.2 s The VC/SC device detects a dead line condition.

0.4 s The CB 1 recloser timer for 3-pole dead time operates. The VC/SC condition is fulfilled and CB 1 is given a reclosing pulse. The CB 1 recloser is put in a blocking state for a certain Reclaim time, e.g. 180 sec. The CB 2 recloser is released.

0.5 s CB 1 recloses and energizes the line.

0.7 s The dead line condition has disappeared but the VC/SC relay operates for synchronous conditions.

0.8 s The CB 2 recloser operates and gives CB 2 a closing command. The recloser is then blocked for the Reclaim time.

0.9 s CB 2 has closed.

---

### AUTO RECLOSE FOR ONE-AND A HALF BREAKER OR

180 s The reclosers reset when reclaim time expires. They are then ready for a new operation.

Above a high-speed Auto reclosing is described but the reclosers can of course also be set for delayed reclosing.

### **Single-pole reclosing**

#### Approximate time plan.

0.0 s. A single-phase fault occurs on the line. Single-pole tripping of CB 1 and CB 2. The CB 1 and CB 2 reclosers are started. The CB 2 recloser is kept waiting by the priority circuit. The reclosers block the pole discordance relays and in applicable cases Earth fault current relays are blocked during the single-pole dead interval.

1.0 s. The CB1 recloser operates. VC or SC is not necessary at single-pole reclosing. CB 1 gets a closing pulse. The CB 1 recloser is blocked for the Reclaim time and the CB 2 recloser released.

1.1 s. CB 1 recloses the open pole.

2.0 s. The CB 2 recloser operates.

2.1 s. CB 2 recloses the open pole.

e.g. 180 seconds. The reclosers reset after the Reclaim time

Influence on the Auto reclosing by various conditions.

1) Delayed tripping. At tripping by delayed steps of Distance relay, or at other back-up relay tripping the reclosers are blocked.

2) The recloser selector switch of one recloser, e.g. CB 1, is set in OFF position. The CB 1 trip relays are then interconnected. At a single-phase fault on Line 1, CB 1 will trip three-pole. CB 2 will trip single-pole and reclose.

3) Communication trouble at Distance relay cooperation in a permissive scheme.

The relay trips instantaneously, but lacking communication (e.g. by power line carrier, PLC) there is a risk that the remote end Distance relay trips with a zone 2 delay. Start recloser is blocked since the line dead time may be too short for fault deionisation.

Alternatively an additional time is added to the 3 phase dead time.

4) One CB was open before the line fault.

Assume that CB 1 is open. The CB 1 conditions for Auto reclosing are not met. At a fault the CB 1 reclosing will not be started and

---

## AUTO RECLOSE FOR ONE-AND A HALF BREAKER OR

# Line protection

it will not delay the CB 2 recloser. CB 2 will reclose without prolonging the dead line time.

5) CB operating gear not charged.

The CB conditions for reclosing are not fulfilled. See point 4 above!

## 6. SYNCHRO CHECK DEVICE

By use of a quick-acting synchronism check functions, high-speed reclosing with synchronism check can be employed and can be a valuable tool to improve operational reliability of a power system. With synchronism check is meant the check of a dead line condition with a Voltage check and the check of the paralleling condition with a check of phase angle and voltage difference with frequency difference within a set limit. Single-pole reclosing does not require any synchronism check.

In the following only three-pole reclosing with Synchro check will be discussed.

Three-pole reclosing can be performed when the two parts of the grid are in synchronism. Synchronism can be secured by circuits in parallel to the tripped line. The possibility that a parallel line could, for instance, be affected by a fault or can temporarily be out of service, must be considered when the need for Synchro check is discussed.

In some cases, for instance with one single line between two parts of the power system, three-pole auto-reclosing cannot be used. It is very unlikely that the two parts maintain synchronism after a three-pole tripping. In such cases one has to refrain from three pole auto-reclosing or limit the use to single-pole tripping and auto-reclosing at single-phase faults. After a three-pole tripping the two parts must be synchronized together.

Figure 29 illustrates power grids with varying degree of meshing. In the systems of fig. 29b, 29c and 29d three-pole reclosing can

---

### SYNCHRO CHECK DEVICE

be utilized. Synchronism check at reclosing is particularly interesting in the cases fig. 29b and 29c.

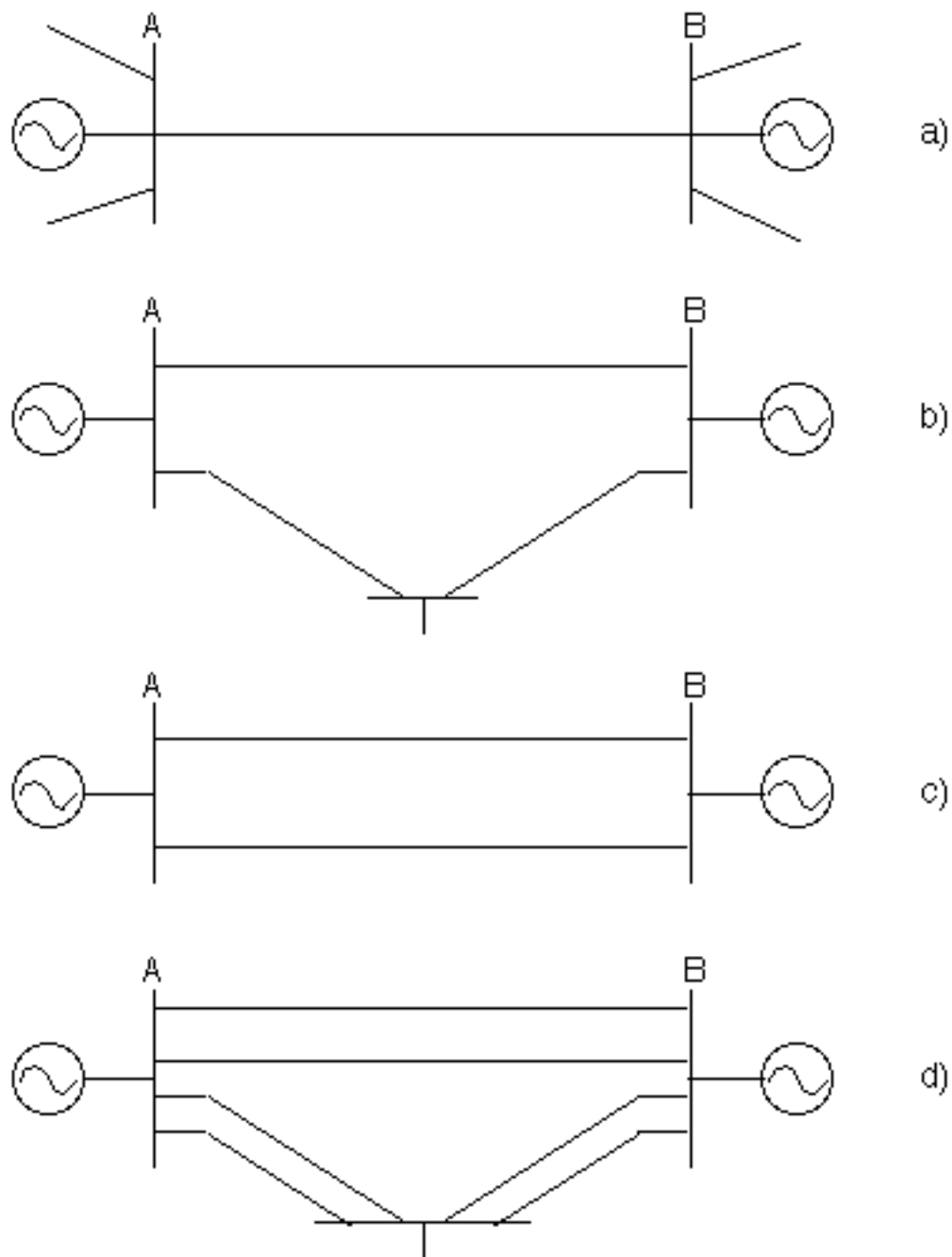

Figure 29. Power grid with different degree of meshing between A and B

---

## SYNCHRO CHECK DEVICE

## 6.1 SYNCHRO CHECK AT HIGH-SPEED AUTO RE-CLOSING

Direct three-pole high-speed Auto reclosing is applied in power grids similar to fig. 29d. It is simple and uncomplicated and gives a short disturbance time.

The fault clearing is made as quick and as simultaneous as possible at the two ends. The Automatic reclosing is performed without any intentional time difference between the ends. Has the fault disappeared at reclosing, the line can immediately pick-up load. The dead line time, and the time the circuit is open, are almost the same.

A certain power system swing is caused by the fault and the switching of the line in and out. After automatic reconnection the system swings back to pre-fault conditions. The amplitudes of the swing depends upon the load transfer before the fault, the fault type, the fault location, the fault clearance time, number and length of parallel lines and other power system parameters.

Care shall be taken not to apply direct Auto-reclosing close to power stations, especially close to thermal plants with turbo generators. A reclosing into a close-up persistent fault would for such applications result in a considerable strain of the generators.

## 6.2 DELAYED AUTO RECLOSING WITH SYNCHRO CHECK

The fault clearance is made simultaneously or with a small non-intentional time difference between the line ends. Delayed auto-reclosing is normally combined with synchronism check.

The C. B. reclosing at one end is then preceded by a live-bus and dead-line check. Once the line is energized, the synchronism can be checked at the other end of the line before completing the auto-reclosing sequence.

The completion of the reclosing is somewhat delayed by the synchronism check. To the dead time is added the time required for the synchronism check and the C. B. closing. This extra time is less important at delayed reclosing. Typical times can be: Dead

---

### SYNCHRO CHECK DEVICE

time 10 seconds, synchro-check time 0.2 seconds, C.B. closing 0.1 seconds, giving 0.3 seconds to be added to the dead time.

As in the case of high-speed reclosing, a swing occurs after the fault and the fault clearance. A sufficiently stable power system swings to a new state and is relatively stable at the instant of delayed reclosing. The synchro-check device checks the voltage levels at both side of the circuit breaker, the voltage level difference, phase angle shift and frequency difference before the Auto reclosing attempt is made.

The difference in voltage and the phase shift, together with line and source impedances, determine the shock at reconnection. At short lines and strong power systems the voltage difference and phase shift are generally small and the synchronism check device should be set in accordance with those conditions.

At long lines on the other hand, the phase shift due to high load through long and weak parallel circuits, may be considerable. The setting must then be at least equally high and it can well be required to be up to  $60^\circ$ . The shock at reclosing will still be moderate due to the high line impedance.

A frequency difference between the two parts of the power system may exist due to a system swing or lost synchronism.

Consider a case according to fig. 29b. The line from B to C is assumed to be open at B. Only little power is transferred between A and B, when a fault occurs on that line. The power system is then split into two parts and can lose synchronism. The two parts may however have just a small difference in frequency. A reclosing of the interconnecting line could fail if the two non-synchronous parts are strong and heavy and the line is incapable of reestablishing synchronism. The synchronism check devices should therefore have a high sensitivity to frequency difference in this kind of application. A sufficiently high sensitivity for frequency difference is not a disadvantage at delayed reclosing as the system is given sufficient time to stabilize before reclosing.

To conclude: A synchronism check device for delayed auto-reclosing shall have the following features:

- a check of voltage level and/or voltage level difference,
- a phase shift sensitivity settable within wide limits,
- a sensitive frequency difference check and

---

## SYNCHRO CHECK DEVICE

# Line protection

- a moderate operation time, typically less than 0.2-0.5 seconds.

## 6.3 HIGH-SPEED AUTO RECLOSING WITH SYNCHRONISM CHECK

In power systems where the stability is strained under periods of high load, one would like to reclose quickly in order to improve the stability. If the parallel interconnection is unreliable, for instance in a system like fig. 29b or 29c, it can be risky to perform a high-speed reclosing without synchronism check. One can then be forced to refrain from reclosing, rely on single pole auto-reclosing at single-phase faults or take a chance with delayed auto-reclosing.

In the latter case the Auto reclosing may be blocked at high loads, which is unfortunate, especially if a high-speed reclosing could have saved the stability. In such cases it would be preferable to adopt high-speed reclosing with dead line check and synchronism check.

When a parallel line is in service Auto-reclosing can then be performed. On the other hand, when the parallel circuit is out of service, the reclosing will be blocked as the synchronism is most likely lost during the dead time.

Auto-reclosing with dead line and synchronism check can in many cases be applied also for lines near a power station.

By choosing to energize the line from the remote end the strain at reclosing into a persistent fault will be moderate. Because the remote end is retripped at a persistent fault, the end near the power station will not be reclosed. Only after a successful line re-energizing the synchronism check conditions will be met and the line reclosing completed.

At a controlled high-speed Auto reclosing the dead line check is made during the dead interval of 0.4-1.0 seconds and a time for dead-line check of 0.2 seconds can be allowed. The synchronism check is made after line reenergizing and the check should be quick to avoid unnecessary delay of the reclosing. It must however wait about 0.1 seconds for a possible retripping of the remote end. Assuming a dead interval of 0.4 seconds, a synchronism check time of 0.2 seconds and time for circuit-breaker closing of

---

### SYNCHRO CHECK DEVICE

0.1 seconds the open-circuit time will be  $0.4 + 0.2 + 0.1$  seconds  
= 0.7 seconds.

One must expect a considerable power system swing at high-speed reclosing of long transmission lines in a system with threatened stability. Therefore, the synchronism check device must not be too sensitive, but allow fairly high values of phase shift and frequency difference. Values of  $70^\circ$  and 200 mHz are realistic. The synchronism check shall be supplemented by a timer to interrupt the auto-reclosing if the check conditions are not met within a short time, e.g. 1 seconds

---

## SYNCHRO CHECK DEVICE



# Line protection

## 6.4 ARRANGEMENT OF SYNCHRO-CHECK UNITS FOR AUTO RECLOSING

In Fig. 30 is indicated Auto reclosing with dead line check at one end and synchronism-check at the other end. It would thus be sufficient with a live-bus/dead-line check unit in the first and a synchronism check device in the other end. Complete synchro-check devices with live bus/dead-line check facility are however usually installed at both ends. In this way the direction of line reenergizing can easily be changed by change of settings.

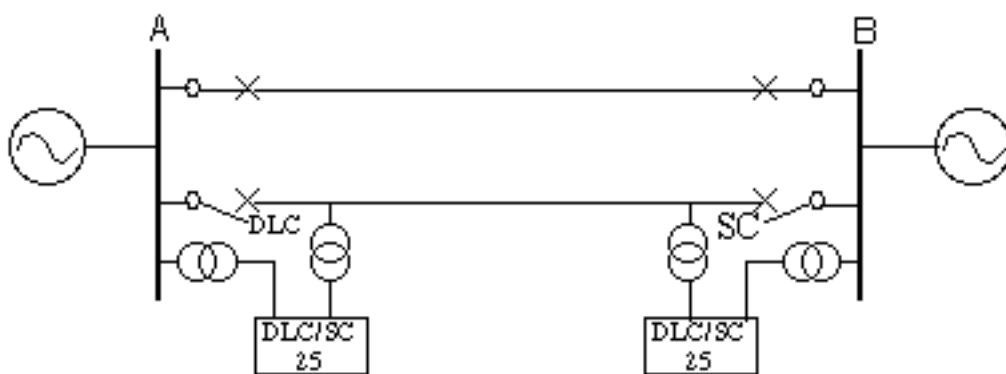

Figure 30. Dead line check (DLC) and synchronism check (SC) at auto-reclosing. 25 = DLC/SC device

Normally there are several lines connected to a substation. It is practical to install a synchro-check device for each line circuit-breaker. In case of a simultaneous tripping of two lines the Auto reclosers can then operate independent of each other. Simultaneous faults could occur at lightning strokes in towers commonly used for two lines. Furthermore, by use of one synchro-check device per line breaker there will not be any need for complicated selection in the voltage and trip circuits.

In stations of breaker- and -a-half, double breaker or ring busbar type, two circuit-breakers per line end are tripped at line faults and shall be reclosed.

The line is energized by one circuit-breaker and if the fault has disappeared, then the other breaker is also reclosed. The order is determined by a priority circuit between the reclosers. In Fig. 31 is shown successive reclosing with dead line check of the first

---

### SYNCHRO CHECK DEVICE

CB closing (A1) and synchronism check of the second CB (A2). Should however the first CB be out of service at the fault, no re-closing is made with this CB.

In that case the second CB shall energize the line and the synchro-check device shall be arranged to permit dead line charging. In the other station sequential Auto reclosing of the CB's is also used but combined with synchronism check as indicated in Fig. 31.

The four synchro-check devices are set in such manner, that A1 and A2 permit reclosing at dead line or at synchronism conditions, but devices B1 and B2 require synchronism at reclosing.

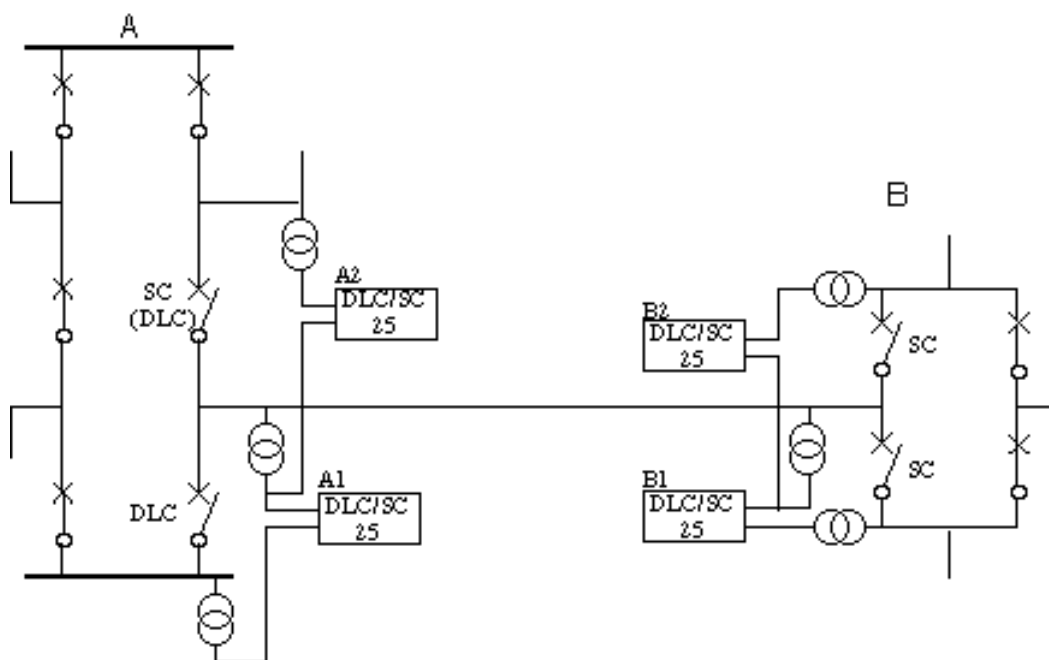

Figure 31. Dead line check and synchronism check at auto-reclosing in a One- and a half-breaker station and a Ring busbar station

## 6.5 SYNCHRO-CHECK RELAY/FUNCTION.

The synchro-check relay measures in a single phase mode the voltage on both sides of the open circuit breaker and it checks:

- Voltage levels
- Difference in voltage level
- Phase angle difference
- Frequency difference

---

### SYNCHRO CHECK DEVICE

# Line protection

When a voltage check function is used it can be set to allow energizing in one or the other, or both directions, or be blocked. To suit different applications there are wide range of application selections or/and settings, which differ with respect to speed and frequency difference sensitivity.

The functions are made to suit the conditions at Quick and Delayed Auto-reclosing as discussed above. It is then set for continuous output signal as long as the conditions are fulfilled and it releases the auto-recloser.

The main characteristics for a suitable Synchro check function are as follows:

Synchro check unit (paralleling check):

Limit for normal voltage  $U_H$ : 45-80% of  $U_n$

Max voltage difference,  $\Delta U = 5-75\%$  of  $U_n$ .

Max phase angle difference,  $\Delta\theta = 5-75^\circ$ .

Max frequency difference,  $\Delta f = 20-200$  mHz

Operation time:  $t = 0.2-0.5$  seconds

Voltage check unit (dead line check):

Limit for dead equipment,  $U_L = 30-80\%$  of  $U_n$

Limit for live equipment,  $U_H = 80\%$  of  $U_n$

Operation time:  $t = 0.1-0.2$  seconds.

## 6.6 7. EXAMPLE OF SYNCHRO CHECK FUNCTION SETTINGS

Reference is made to Users Guide for the different functions/ relays.

Application: High-speed auto-reclosing.

On all four SC/VC functions in Fig. 29 above are set:

Nominal voltage  $U_1, U_2: U_n = 110/63.5$  V

- Voltage difference  $\Delta U$ : e.g. 15% of  $U_n$

- Phase angle difference  $\Delta\theta$ : e.g.  $45^\circ$

The Synchro check function is set for continuous output signal when conditions are fulfilled.

Unit A1 is set for line energizing: Dead Line - Live Bus DLLB

---

### SYNCHRO CHECK DEVICE

Continuous output

No delay.

Dead line voltage:

The unit A2 can be set at energizing "BOTH" i. e. allowing energizing of one or the other direction. The other settings are as for A1.

The B1 and B2 units are set with Dead line energizing blocked. The other settings are as for A1.

## **7. LINE PROTECTION SYSTEM**

### **7.1 GENERAL DESIGN**

A block diagram for a EHV/HV line protection system is shown in Appendix 1.

A redundant protection scheme with two Distance protection relays is provided. The high resistive earth faults are detected by a Directional earth fault relay (DEF), including communication with remote end in a permissive or blocking scheme. The DEF is provided in one of the systems only as the consequences for the power network are smaller due to the lower magnitude of fault current and as the fault is in one phase only. These high ohmic faults will also develop to a low ohmic fault if not cleared within a reasonable time and fault clearance is thus secured in both sub systems.

An Auto-Reclosing device is provided to restore the normal operation as quick as possible. To verify that Auto-Reclosing can take place at multi-phase faults a Synchro check function is provided.

To measure the distance to the fault, thus simplifying the localization, a Fault locator is supplied as an option to the Distance protection. This will much improve the time to repair for a fault on a long transmission line.

A Fault recorder is included to register the analogue signal at the faults, enabling a post fault analyze to check the behavior of the protection system and by that improve the total reliability.

---

### **LINE PROTECTION SYSTEM**

# Line protection

A Breaker failure relay is provided to transfer the trip to the surrounding breakers. This is only used for the case where the line breaker fails to trip.

In Appendix 2 a MV/HV cable line protection based on a Differential relay and a back-up protection with directional short circuit and Earth fault protection.

## Appendix 1

The protection system Block diagram for a EHV/HV Line.

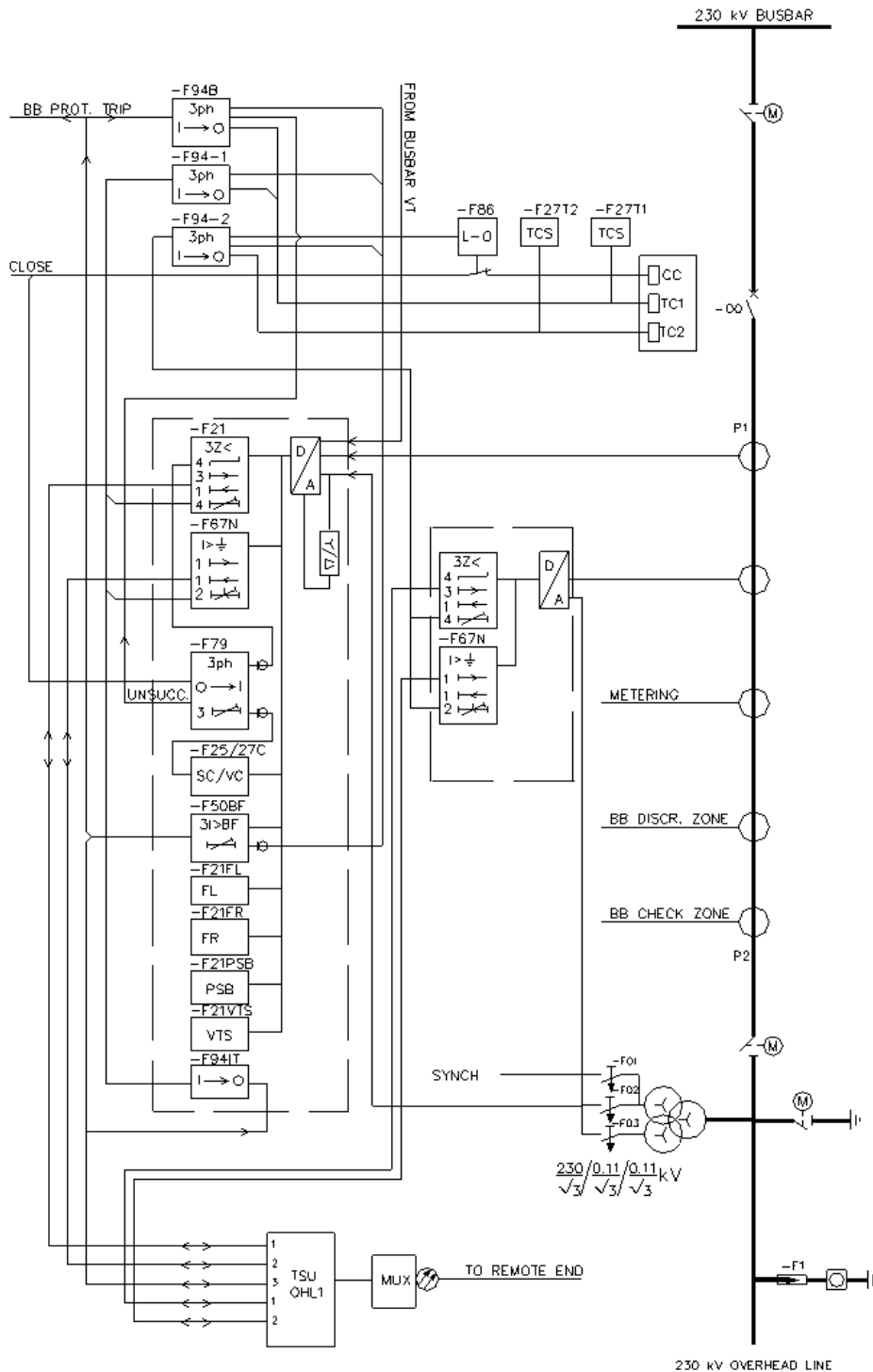

## LINE PROTECTION SYSTEM

# Line protection

## Appendix 2

The protection system Block diagram for a HV/MV Cable.

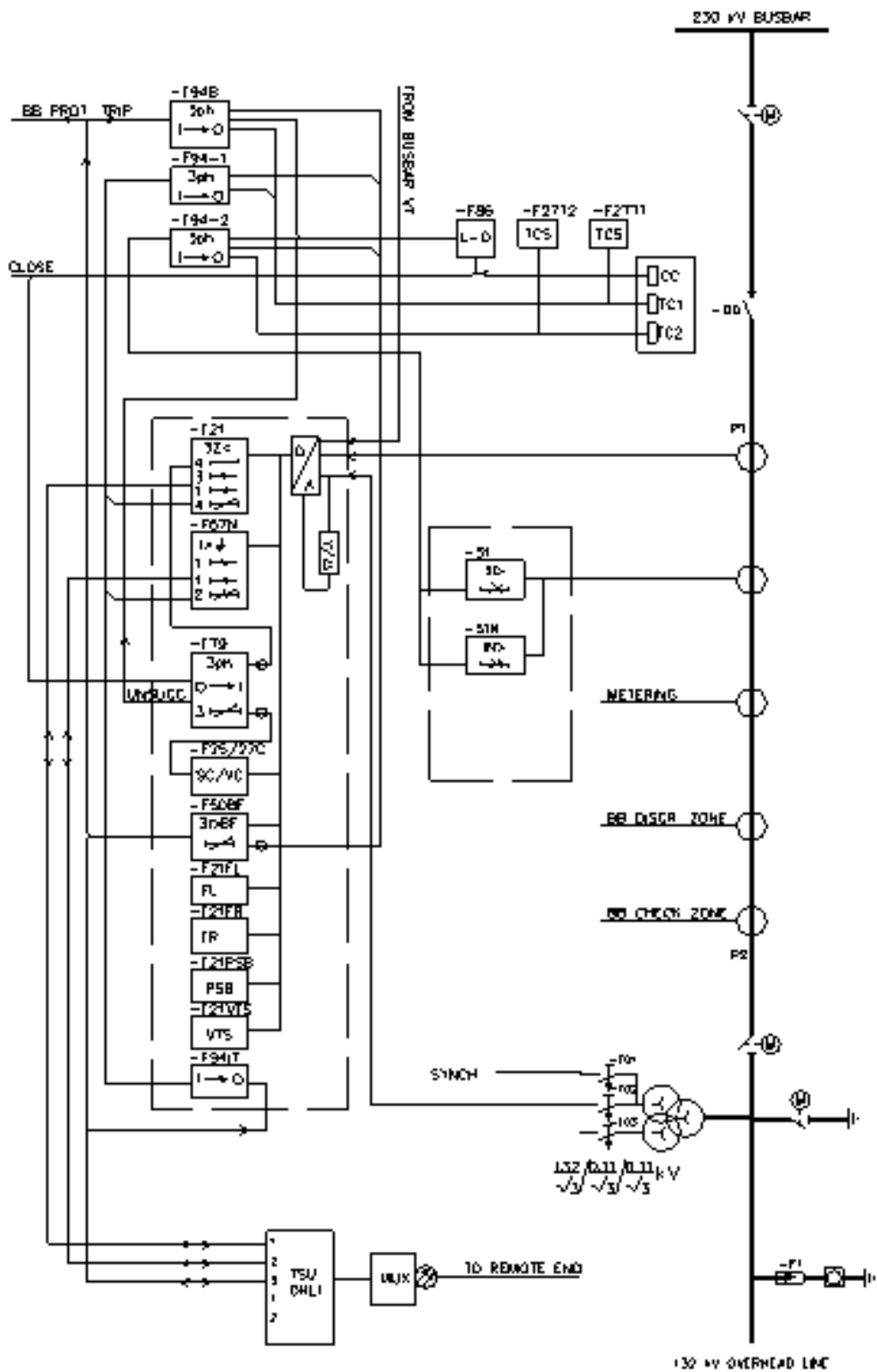

## LINE PROTECTION SYSTEM



# Line protection

## Appendix 3

The Auto Reclosers and Line protection for a One- and a Half Breaker Bay section.

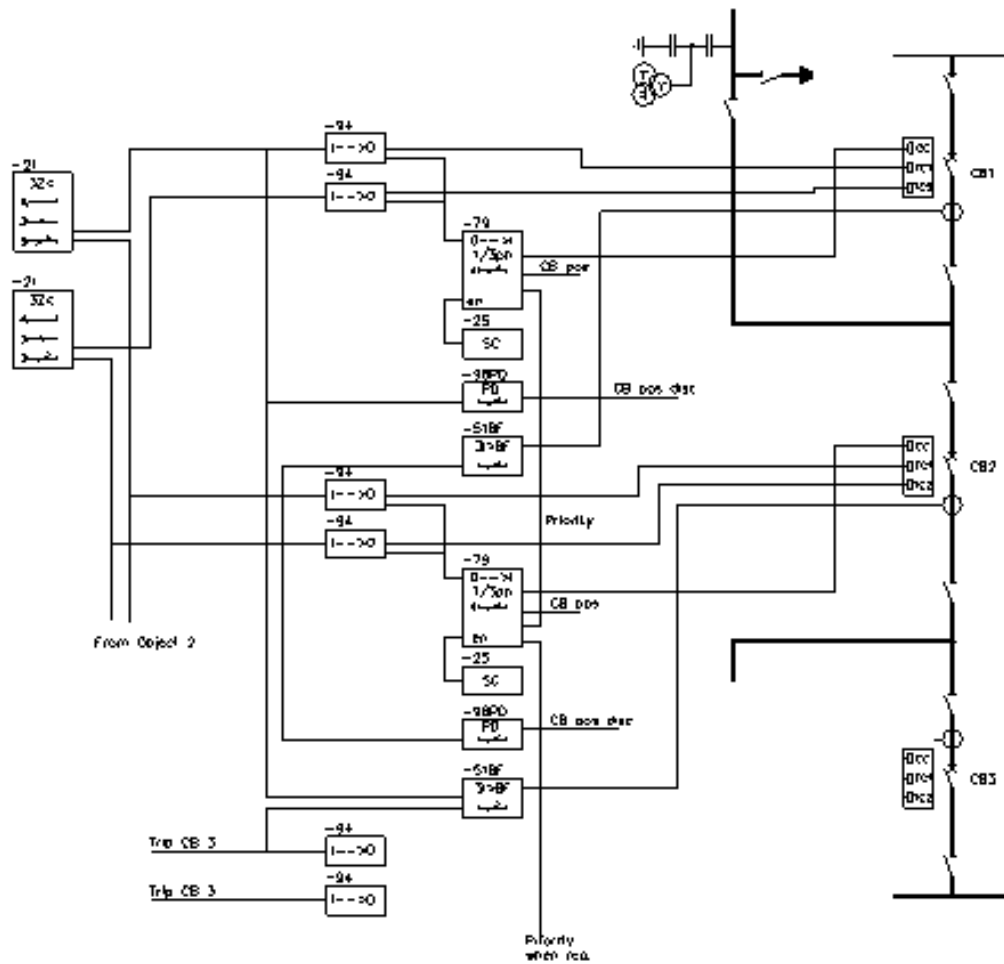

### LINE PROTECTION SYSTEM

---

## LINE PROTECTION SYSTEM

# Transformer Protection

## 1. INTRODUCTION

A power transformer is an important and expensive part of a power network. High availability of the power transformer is therefore very important in order to prevent disturbances in the power networks transfer of power.

A high quality power transformer, correctly designed and with suitable protection relays and supervision is very reliable. Less than one fault per 100 transformer and year can be expected.

When a fault occurs in a power transformer this will normally cause severe damage. The power transformer has to be transported to a workshop for reparation, which takes considerable time. Operation of a power network, when the power transformer is out of service is always difficult. A power transformer fault therefore often is a more severe disturbance for the network, than an overhead line fault which usually can be repaired rather quickly.

## 2. CONDITIONS LEADING TO FAULTS

### **Insulation breakdown**

Insulation breakdown of the windings will cause short-circuits and/or earth-faults. These faults causes severe damage on the windings and the transformer core. In addition to that an overpressure may develop damaging the transformer tank.

Insulation breakdown, between windings or between winding and core can be caused by:

- Ageing of insulation due to overtemperature during a long time.
- Contaminated oil.
- Corona discharges in the insulation.
- Transient overvoltages, due to lightning or switching, in the network.

---

## INTRODUCTION

- Current forces on the windings due to high currents at external faults or the inrush currents when a transformer is energized.

## 3. RELAY PROTECTION

### 3.1 GENERAL

When a fault occur in a power transformer, the damage will be proportional to the fault clearance time. The power transformer therefore must be disconnected, as quick as possible. It is of out-most importance that quick and reliable protection relays are used to detect faults and initiate tripping.

Monitors at the power transformer can also be used for detecting of abnormal conditions which may develop into a fault.

The power transformers size and voltage level influences the extent the choice of monitors and the protection relays used to limit the damage at an possible fault. The cost for these is small compared both to the total cost of the power transformer and the cost due to a transformer fault.

There are often different opinions about the extent of transformer protection. However, transformers with oil conservators usually are equipped with the following protection and monitoring:

#### Transformers larger than 5MVA

- Pressure guard (Buchholz-relay).
- Overload protection (normally winding temperature supervision within the transformer).
- Overcurrent protection.
- Earth fault protection.
- Differential protection.
- Pressure relay for tap changer compartment.
- Oil level monitor.

#### Transformers smaller than 5MVA

---

## RELAY PROTECTION

# Transformer Protection

- Pressure guard (Buchholz-relay).
- Overload protection (normally winding temperature supervision within the transformer).
- Overcurrent protection.
- Earth fault protection.
- Oil level monitor.

## 3.2 DIFFERENTIAL PROTECTION OF LOW IMPEDANCE TYPE

A differential protection compares the currents flowing into and out from the transformer. Auxiliary current transformer “aux.ct:s”, for adjusting the phase angle and ratio are necessary. Ratio correction is normally calculated for tap changer at middle position.

In new numerical protection relays aux.ct:s are not necessary. Phase shift, voltage levels and CT-ratios are then programmed into the protection and compensated for at differential current measurement. Further zero sequence current filtering is also made in software whereas in older static relays this was made by including delta windings in the auxiliary current transformers.

A differential protection must operate quickly, when the differential current exceeds the settings of the relay and only operate for a fault within its zone. The protection therefore must be stable concerning:

- Inrush currents.
- Through fault currents.
- Overfluxing of the transformer.

This must be ensured, even with a tap-changer in the end position.

### **Inrush current**

Inrush current develop, when the transformer is connected to the network. The magnitude and duration are dependent on:

---

## RELAY PROTECTION

- Transformer size and design.
- Source impedance.
- Remanence of the core.
- Point of the sinus wave at which the transformer is switched on.

Inrush currents can develop in all phases and in an earthed neutral. Currents of magnitude 5-10 times the transformers rated current can be obtained.

Inrush current can have the shape shown in fig. 1. Maximum inrush is achieved when the transformer is switched in at zero voltage and the magnetic flux, from the inrush current, have the same direction as the remanence flux of the core. The two fluxes are added and the core can saturate. When the transformer core saturates the inrush current is only limited by the network source impedance and transformer residual impedance.

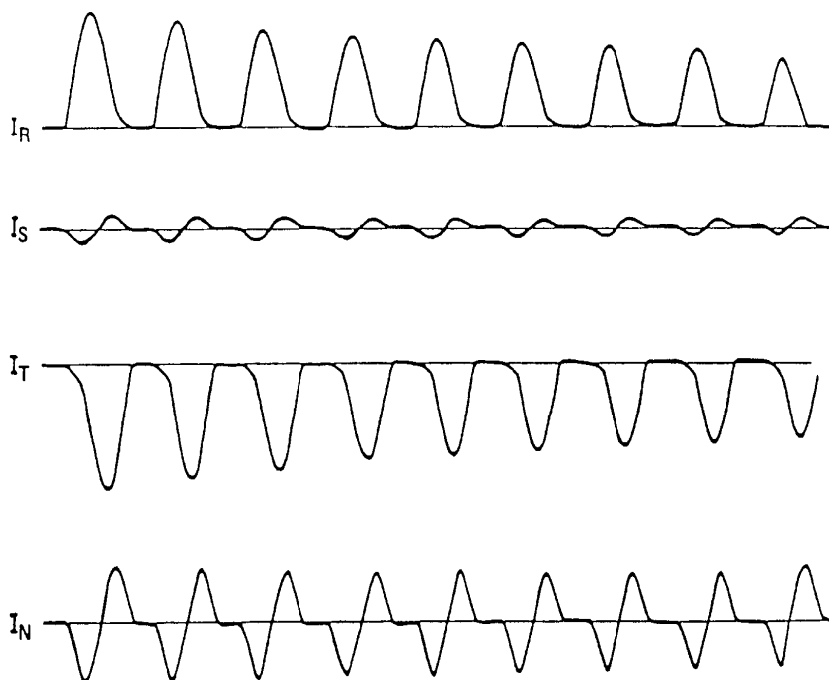

Figure 1. Recorded inrush current for a 60MVA transformer 140/40/6,6kV, connected YNyd

When the new flux at the swithing in have the opposite direction of the remanence flux, no saturation of the core will be obtained and the inrush current will be comparatively small. The size of the inrush current therefore is dependent of where on the wave the transformer is switched in.

---

## RELAY PROTECTION

# Transformer Protection

The inrush current also have a large DC-component and is rich of harmonics. The fundamental frequency and the second harmonic are dominating. Damping of the inrush current is dependent on the total resistance of the feeding network. Duration can vary from less than 1 second, up to minutes in extreme cases, when a transformer is switched in, in parallel with another, already energized, transformer.

In order to prevent unwanted functions at switching in the transformer the differential protection is supplied with a second harmonic restraint measuring the content of second harmonic compared with the fundamental frequency. The second harmonic restraint will block unwanted tripping by increasing the stabilization if the second harmonic content is large. A normal content is >13-20% depending on the manufacture and type. For modern numerical relays the stabilization level can be set for each application.

## **Normal service**

At normal service there will be a small differential (unbalanced) current flow due to mismatch of ratio (aux.ct:s normally have a limited number of taps and will not get exact adjustment), power transformer magnetizing current and the position of the tap-changer. The position of the tap changer is the factor that gives the dominating differential current.

## **External faults**

The “normal” differential current in service increases at an external fault. A through fault of 10 times the rated current (with a tap changer at end position) can cause a differential current of 1-2 times the power transformer rated current.

In order not to maloperate under these conditions the differential protection is provided with a percentage, through fault, restraint circuit. The percentage restraint ensures that the function only is obtained if the differential current reaches a certain percentage of the total through fault current (see fig. 2).

The current  $(I_1+I_2)/2$  is the measured through fault current and the differential current required for operation will increase with in-

---

## RELAY PROTECTION

creasing through fault current and a stabilization for the differential current achieved due to tap changer in offset position is then achieved.

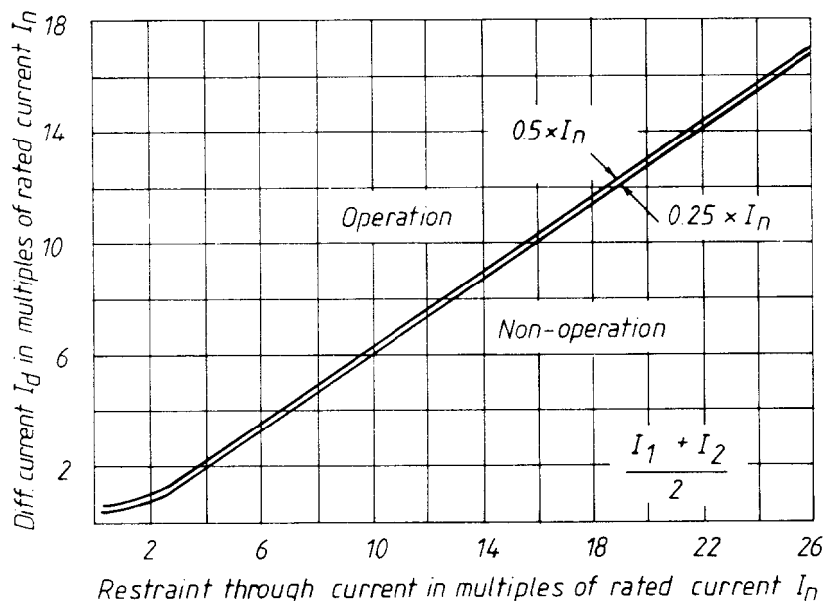

Figure 2. Through fault restraint gives an increased required differential current when the through fault current is increasing.

### Overexcitation

Overexcitation of a transformer means that the magnetic flux in the core is increased above the normal design level. This will cause an increase of the magnetizing current and the transformer can be damaged if this situation isn't taken care of.

Overexcitation of transformers in transmission and distribution networks is caused by overvoltages in the network.

For step-up transformers connected to generators during start-up, overexcitation can occur since the flux is dependent of the factor voltage/frequency. This means that the voltage must be gradually increased, with increasing frequency, in order not to overexcite the transformer.

The overexcitation is not an internal transformer fault, although can lead to one. The differential protection must therefore be stabilized under these conditions as tripping of transformers and thus load will only mean that the overvoltage condition in the network is becoming worse.

---

## RELAY PROTECTION



# Transformer Protection

The current during overexcitation has a lot of fifth harmonic, see fig. 3. This fact is utilized in modern transformer protection to stabilize the transformer against unwanted functions during these kind of conditions.

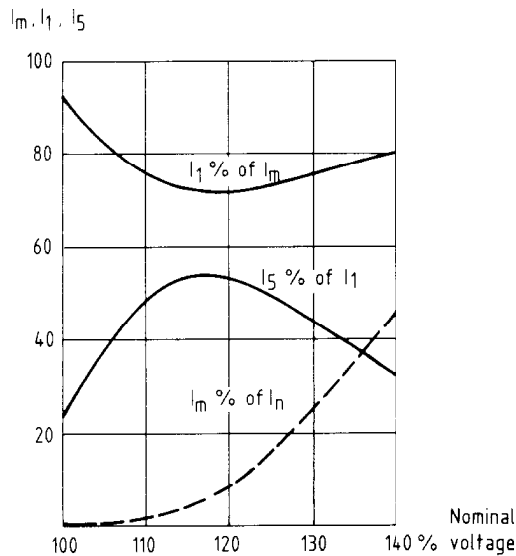

Figure 3. Magnetizing current at Overexcitation where “ $I_1$ ” is the fundamental frequency current, “ $I_5$ ” is the fifth harmonic current, “ $I_m$ ” is the total magnetizing current and “ $I_n$ ” is the nominal current.

If overexcitation of the transformer due to overvoltage or under-frequency is likely to happen, a separate overexcitation protection should be supplied. This protection has inverse characteristics according to the transformers capability to restrain overexcitation “ $V/Hz$ ”. This protection must be connected to a transformer winding with fixed number of turns. If the transformer is supplied with tap changer the protection must be connected to a side without tap changer. The side with the tap changer can withstand different voltages depending on the tap changer position and is therefore not suitable for overexcitation protection.

## 3.3 DIFFERENTIAL PROTECTION FOR

---

### RELAY PROTECTION

## AUTO-TRANSFORMERS

For auto-transformers a high impedance type of differential protection can be used. CT:s with the same ratio and no turn correction are then supplied at both high and low voltage side of the transformer as well as in each phase of the neutral.

With this type of protection a higher sensitivity, 5-10% of rated current, and a faster tripping (10-15ms) compared with the low impedance type can be obtained.

Drawbacks with this type of protection can be:

- If the transformer is delivered separately, it can be difficult to get each phase, at the neutral side of the winding.
- Delta winding of the transformer has to be protected separately.

### 3.4 BACK-UP PROTECTION RELAYS

A transformer is always supplied with a number of back-up protection relays, e.g. back-up for short circuits or earth faults in the low side system. These protection relays are definite or inverse time delayed and connected to high- and low voltage side as well as on the neutral side/sides for the earth fault functions.

They will provide system back-up rather than being back-up for internal system faults, e. g. the short circuit protection on the HV side of the transformer provides back-up to the short circuit protection on the outgoing feeders when these fails to clear the fault. UN protection in the LV bay or a IN protection in the transformer neutral will provide back-up protection for earth fault protection relays on the outgoing feeders.

#### **Monitoring on the transformer**

The monitoring devices on the transformer are often the main protection. They detect abnormal service conditions, which can lead to a fault. They can also quickly detect internal faults e. g. the Buchholz relay. Typical location of monitors is shown in fig. 4.

# Transformer Protection

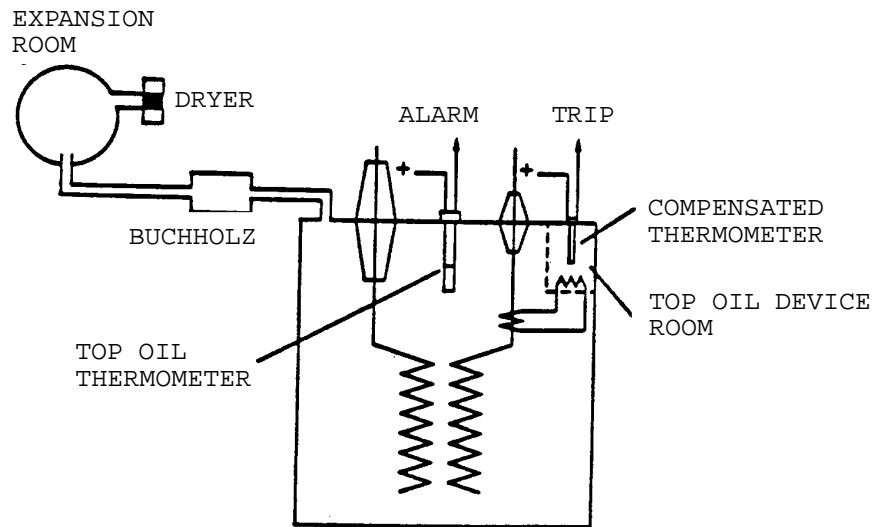

Figure 4. Location of buchholz, top oil thermometer and winding temperature indication

## Gas detector relay (Buchholz)

At a fault in an oil immersed transformer the arc will cause the oil to decompose and gas will be released. The gas will pass through the pipe between the main tank and the conservator and can be detected by a gas detector relay.

The gas detector have an alarm unit collecting the gas, and one unit for tripping responding to the high flow of gas at a serious internal fault.

The collected gas can be analyzed and give information about what caused the gas.

It should be noted that the trip signal from the Buchholz sometimes can be very short at a serious internal fault due to that the relay will be destroyed (blown away). Receiving of this signal in the relay system therefore must have a seal-in feature to ensure that a sufficient length of the tripping signal is given to the CB and to indication relays.

---

## RELAY PROTECTION

### **Temperature monitoring**

A too high temperature in a transformer can be caused by overloading or by problems in the cooling equipment. Overfluxing can also cause a temperature raise.

Oil immersed transformers are supervised with thermometers. These are included in the power transformer standard equipment. There are two types to choose between, oil-, or winding temperature measuring devices and both are normally supplied on transformers bigger than a few MVA.

Both types are overloading sensors for the transformer. There is normally one alarm and one trip level at each type of measuring devices.

## **4. PROTECTION BLOCK DIAGRAM**

The protection system for a typical HV/MV power transformer is shown in figure 5. It should be noted the mix between protection for internal transformer faults and the back-up protection provided for external faults mainly in the low voltage system.

---

### **PROTECTION BLOCK DIAGRAM**

# Transformer Protection

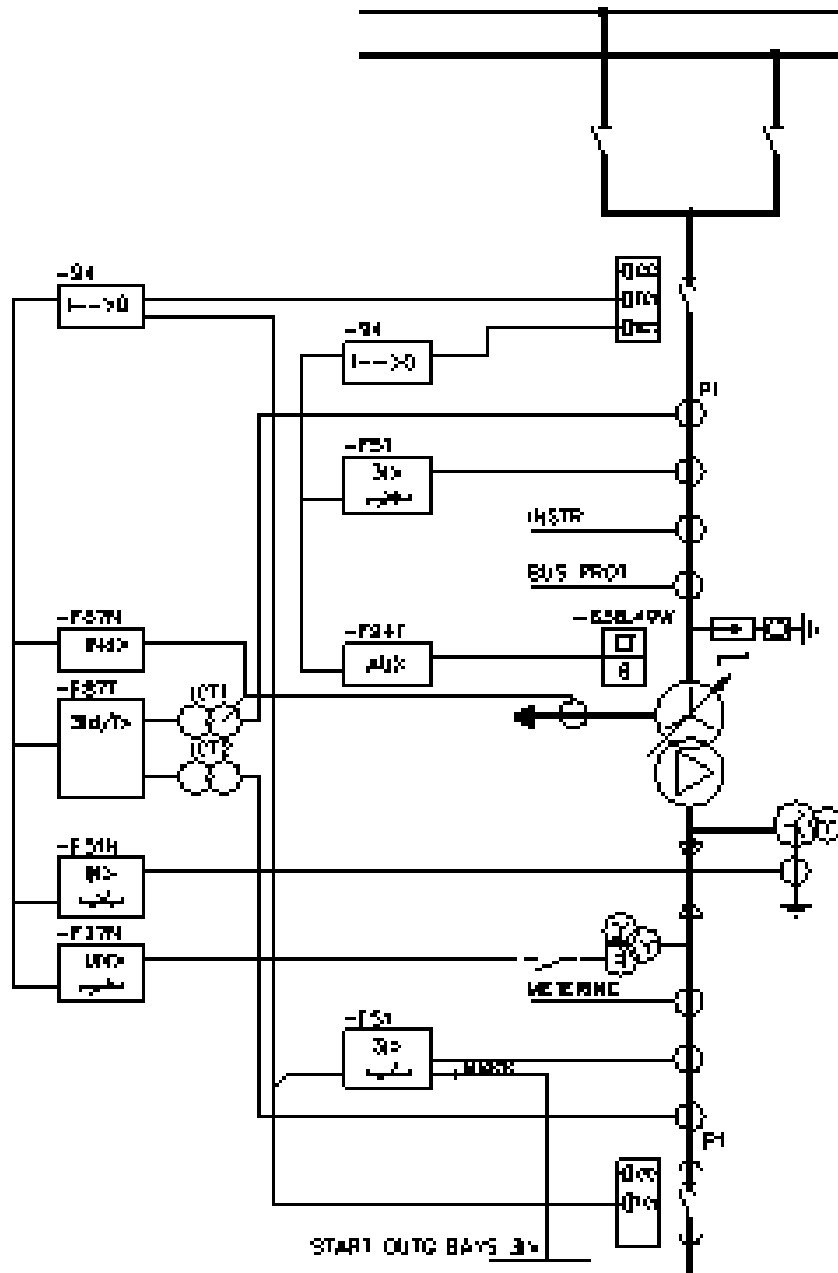

Figure 5. A typical protection system for a HV/MV power transformer.

---

## PROTECTION BLOCK DIAGRAM

The protection system for a typical EHV/HV power transformer is shown in figure 6. For such big system transformers a sub-divided protection system is normally required and provided. Further back-up protection are often of impedance type to allow setting matching the line protection on the outgoing lines.

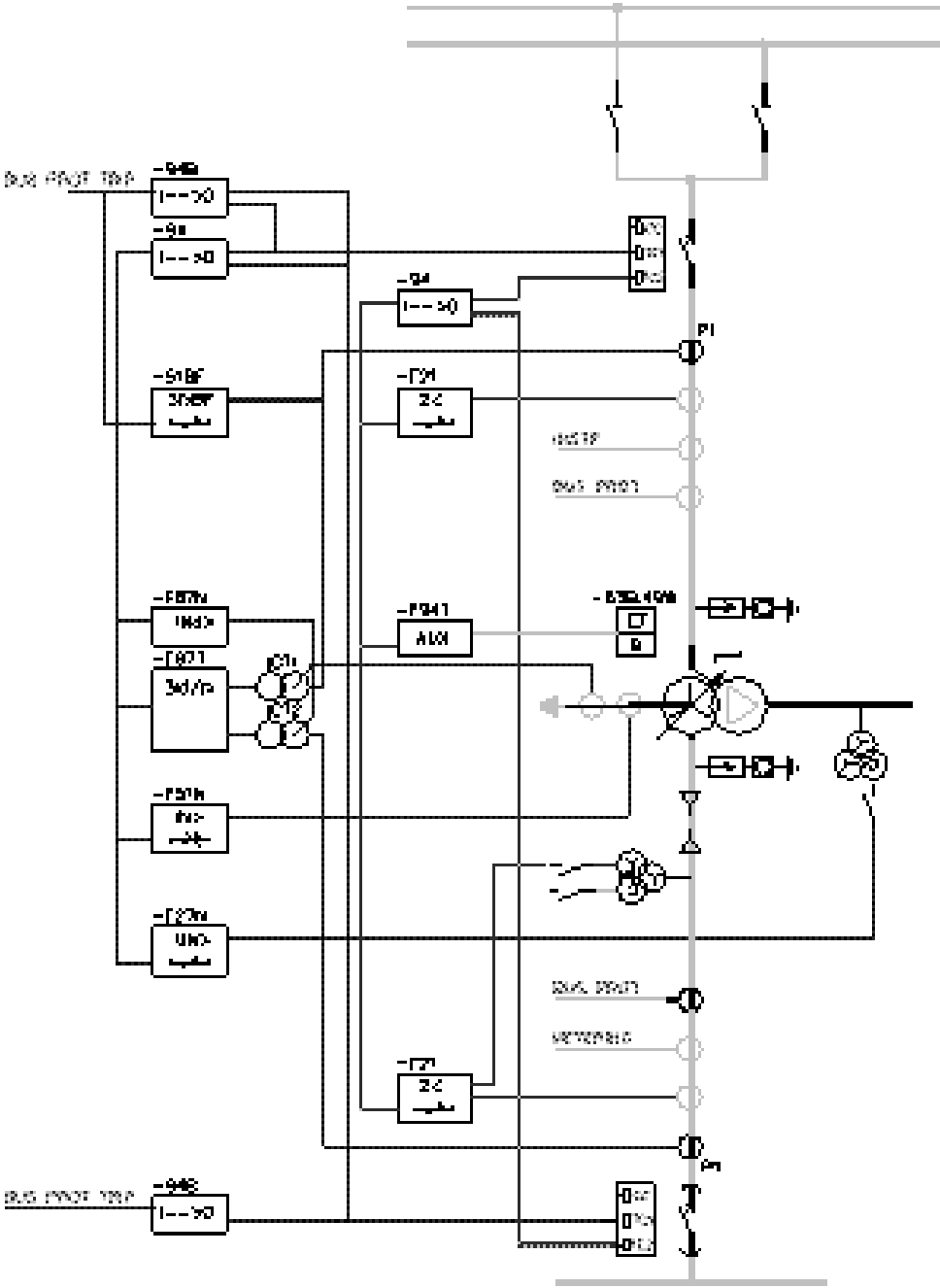

Figure 6. A typical protection system for a EHV/HV system power transformer.

PROTECTION BLOCK DIAGRAM

# Reactor Protection

## 1. NEED FOR SHUNT REACTORS

Shunt reactors are used in high voltage systems to compensate for the capacitive generation of long overhead lines or extended cable networks.

The reasons for using shunt reactors are mainly two. The first reason is to limit the overvoltages and the second reason is to limit the transfer of reactive power in the network.

If the reactive power transfer is minimized i. e. the reactive power is balanced in the different part of the networks, a higher level of active power can be transferred in the network.

Reactors to limit overvoltages are most needed in weak power systems, i.e. when network short-circuit power is relatively low. Voltage increase in a system due to the capacitive generation is:

$$\Delta U(\%) = \frac{Q_c \times 100}{S_{shc}}$$

where “ $Q_c$ ” is the capacitive input of reactive power to the network and “ $S_{sh.c}$ ” is the short circuit power of the network.

With increasing short circuit power of the network the voltage increase will be lower and the need of compensation to limit overvoltages will be less accentuated.

Reactors to achieve reactive power balance in the different part of the network are most needed in heavy loaded networks where new lines cannot be built because of environmental reasons. Reactors for this purpose mostly are thyristor controlled in order to adapt fast to the reactive power required.

Especially in industrial areas with arc furnaces the reactive power demand is fluctuating between each half cycle. In such applications there are usually combinations of thyristor controlled reactors (TCR) and thyristor switched capacitor banks (TSC). These together makes it possible to both absorb, and generate reactive power according to the momentary demand.

---

### NEED FOR SHUNT REACTORS

Four leg reactors also can be used for extinction of the secondary arc at single-phase reclosing in long transmission lines. Since there always is a capacitive coupling between phases, this capacitance will give a current keeping the arc burning, a secondary arc. By adding one single-phase reactor in the neutral the secondary arc can be extinguished and the single-phase auto-reclosing successful.

## 2. CONNECTIONS IN THE SUBSTATION

The reactors can be connected to the busbar, a transformer tertiary winding or directly to the line, with or without a circuit-breaker (see figure 1).

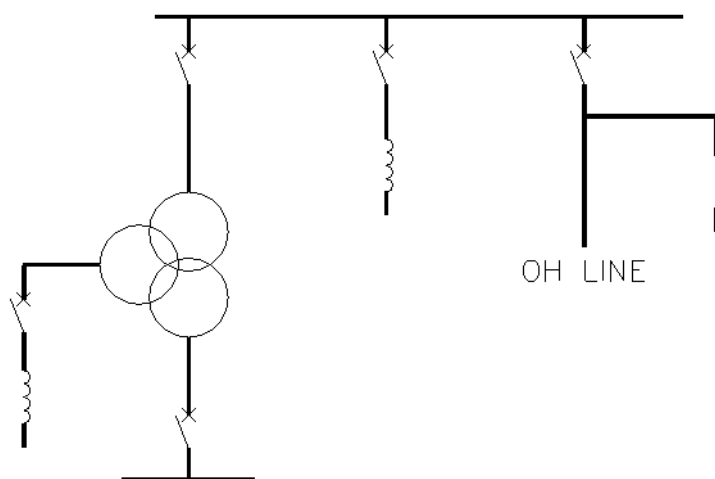

Figure 1. Different locations of shunt reactors.

Tertiary connected reactors will have the lowest cost but extra losses will be obtained in the transformer. The rated voltage of the reactor must be taken into account as well as the large voltage drop at the power transformers.

A voltage drop in the tertiary, equal to the power transformer impedance, will be obtained when the reactor is connected. Lets assume that the transformer have an impedance voltage of 15% and a rated voltage in the tertiary of 20 kV. Also assume that the

---

### CONNECTIONS IN THE SUBSTATION



# Reactor Protection

auxiliary power to the station is taken from the tertiary through a 20/0.4 kV transformer.

When a reactor with rated power equal to the rated power of the tertiary winding, is connected, the voltage in the tertiary will decrease to  $0.85 \times 20 = 17$  kV. This will also mean that the auxiliary power voltage will decrease with 15% and some kind of voltage stabilization regulation is therefore necessary to keep the 0.4 kV voltage level within required limits.

If the reactors are to be used for secondary arc extinction at single-pole reclosing, they must be connected directly to the line. This also have to be done if the reactors are supposed to keep down the voltage at the open end of a long transmission line.

Busbar connected reactors can be used for voltage regulation and reactive power balance.

Line Reactors can either be connected continuously together with its line, or be connected to the network at low load conditions.

## **3. SYNCHRONOUS SWITCHING OF SHUNT REACTOR CIRCUIT-BREAKERS**

Synchronized closing, and opening of shunt reactors CB:s, is possible by using the Switchsync relay. This will give the closing impulse at the correct instance to achieve pole closing at maxi-

mum phase voltages. Closing at voltage maximum gives the minimum possible disturbances in the network (see fig. 2).

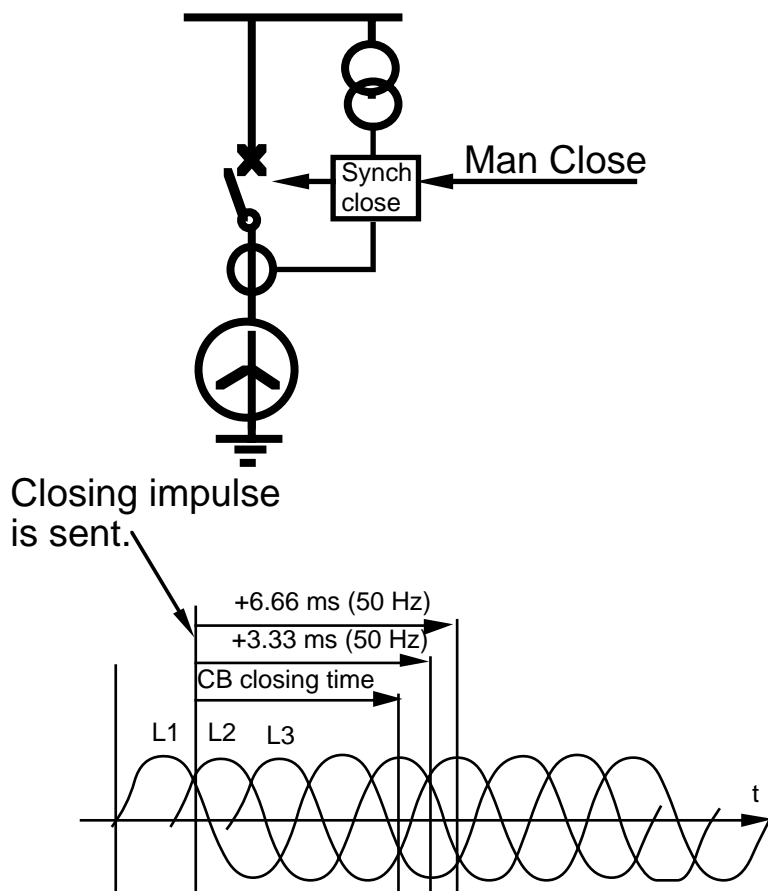

Figure 2. Synchronized closing of Shunt Reactor Circuit Breakers.

Shunt reactors CB:s should be closed at voltage maximum. CB:s with Switchsync relay to control the closing instance don't require any pre-insertion resistors, which mean a less mechanical complex CB, and of course, a less expensive CB.

Switchsync can also be equipped with an adaptive control which automatically will adjust to changes in the CB:s operating time.

## 4. THYRISTOR (PHASE-ANGLE) CONTROLLED REACTORS (TCR)

In order to get a continuous control of the reactive power and to damp power swings in the network, thyristor controlled reactors

---

### THYRISTOR (PHASE-ANGLE) CONTROLLED REACTORS

# Reactor Protection

can be installed. These can respond within only half a cycle delay to the required amount of reactive power needed.

The current is controlled in such a way, that the firing pulses to the thyristors are delayed so that they won't disturb the natural zero crossings of the current. This regulating can be done continuously and reactive power can therefore be steplessly adjusted to the required value (see fig. 3).

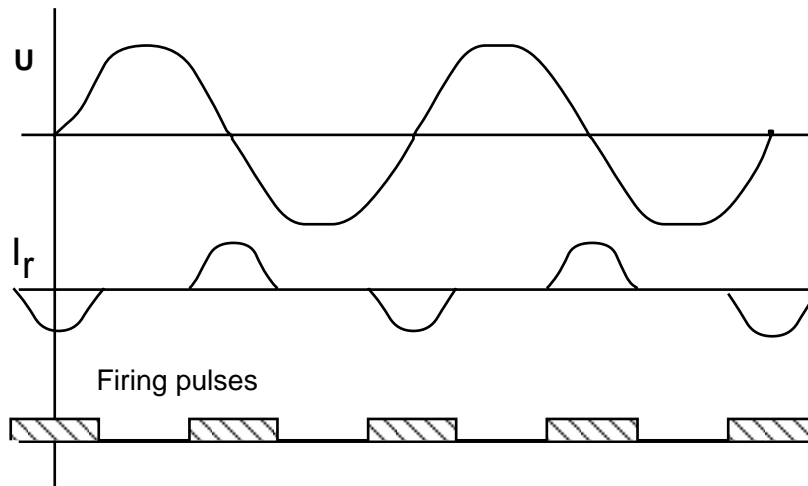

Figure 3. Voltage and current wave form and thyristor firing control.

This control is practically transient free but causes harmonics, that have to be taken care of by harmonic filters. The harmonics generated, are " $n \times f \pm 1$ ", where " $n$ " is an integer. The harmonics of the lowest order are the largest and the level decrease with higher orders. Filters therefore normally only are needed for 5'th, and 7'th harmonics.

TCR reactors are always both connected to the network through a power transformer, and delta connected (see fig. 4). The voltage level is chosen to get a current suitable for the rated currents of the thyristors selected.

---

## THYRISTOR (PHASE-ANGLE) CONTROLLED REACTORS

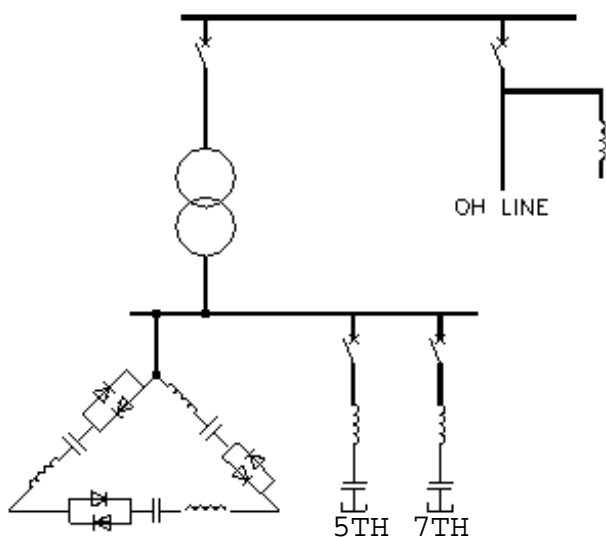

Figure 4. Thyristor controlled reactors (TCR).

## 5. SINGLE, AND THREE-PHASE REACTORS

Three-phase reactors are manufactured for system voltages up to 400 kV. At higher voltages the reactors usually are of single-phase type and more or less necessary for the operation of the system. Using single-phase units makes it easier with spares, as only one single phase unit have to be kept in the substation.

Sizes can either be standardized by the customer or individually optimized for each case.

## 6. RELAY PROTECTION FOR DIRECT EARTHED SR:S

A differential relay, of high impedance type should be used as main protection. CT:s should be specified at both the phase and the neutral side of each phase and a three phase protection should be used as a three phase protection gives a higher sensitivity for internal faults.

---

### SINGLE, AND THREE-PHASE REACTORS

# Reactor Protection

If the reactor has its own CB, the CT:s at the phase side could be located together with the CB. If the reactor is connected without CB a bushing CT:s should be used.

CT:s on the neutral side of the winding should be integrated in the reactor (bushing CT:s). If it isn't possible to get one CT at each phase on the neutral side a common CT at the earth connection, must be supplied. In this case a single-phase high impedance protection should be supplied.

A three-phase overcurrent protection should be used as back-up protection. Earth fault current is normally not supplied since the residual current will be equal to the load current during internal, as well as external faults. In addition to this the inrush current in the neutral is both high and long lasting. This means that setting of an included earth fault current protection would in principle be the same as the overcurrent protection and any increase of the sensitivity can not be obtained by earth fault current protection and it is thus not required.

## **7. DESIGN OF HIGH IMPEDANCE DIFFERENTIAL PROTECTION RADHA**

### **7.1 RELAY SETTING**

The general requirement on the function values of the high impedance differential protection is that at maximum through fault current for an external faults the relay wont maloperate even with one CT fully saturated.

For a reactor the dimensioning criteria will be for the inrush current, since a reactor only will give a through fault current equal to rated current, at an external earth-fault.

---

#### DESIGN OF HIGH IMPEDANCE DIFFERENTIAL PROTEC-

The maximum inrush current for a reactor is approximately two times the rated current. If no specific requirement concerning at what current the relay should be stable exists, five times the rated current is used when operating voltage is selected.

This rather high value is set in order not to get problem at reactor breaker openings. As the CB is chopping the current at opening, a high frequency current (1-12 kHz) will oscillate between the reactor reactance and the circuits leakage capacitance. This oscillating current could lead to maloperation of the Differential relay. If there are maloperation problems at opening of the CB, the remedy for this is to connect a capacitor in the relay circuit.

The function value of the relay should be chosen:

$$U_{\text{function}} \geq 5I_n(R_{\text{ct}} + 2R_l)$$

where “ $I_n$ ” is the reactors rated current at the secondary side of the CT, “ $R_{\text{ct}}$ ” is CT secondary resistance at 75 °C and “ $R_l$ ” is the lead resistance, from the CT to the summation point. The principal connection for one phase is shown in fig. 5.

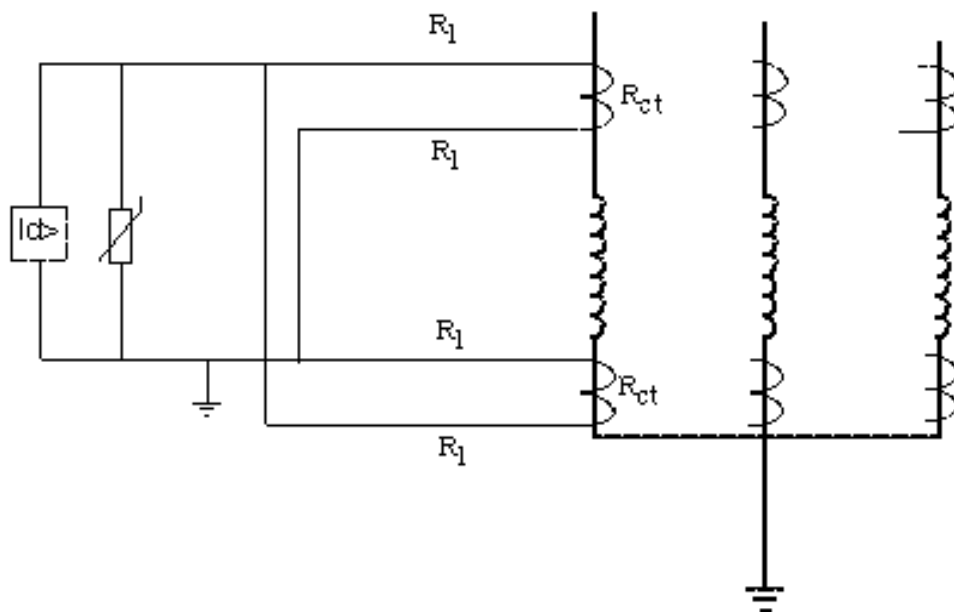

Figure 5. Connection principle for a high impedance differential protection.

In order to protect RADHA, from overvoltages at internal faults, non-linear resistors are connected, in parallel with the relay, at each phase (see fig. 5).

# Reactor Protection

## 7.2 CURRENT TRANSFORMER DESIGN

CT:s for High impedance type Differential protection must have a saturation, or knee-point voltage, of at least twice the selected operation value of the relay. CT:s must not be equipped with turn correction since this could lead to maloperation of the protection.

If possible the CT:s on the phase and neutral side should be made with similar magnetizing characteristic.

The ratio of the CT:s should be chosen corresponding to approximately twice the rated current. This is done in order to not getting too few secondary turns. Secondary rated currents should be selected to 1 A, since the primary rated current usually is quite low, and 5 A will give too few secondary turns.

## 7.3 PRIMARY SENSITIVITY

Primary sensitivity of approximately 10-15% of the reactors rated current normally can be obtained.

The primary sensitivity can be calculated as:

$$I_p = n(I_r + I_{res} + I_m)$$

where

“ $I_p$ ” is the protection primary operation current

“ $n$ ” is the current transformer ratio

“ $I_r$ ” is the current through the relay at function

“ $I_{res}$ ” is the current through the voltage dependent resistor

“ $I_m$ ” is the sum of the magnetizing currents.

For this calculation the actual angles for the different currents must be considered.

“ $I_r$ ” angle is given in relay catalogues and for RADHA and RADHD angle is +20-40 degrees depending on function value and frequency.

“ $I_{res}$ ” is purely resistive and have an angle of 0 degrees.

“ $I_m$ ” angle vary depending on applied voltage but -60 degrees is a good approximation that can be used for this calculation.



# Capacitor Protection

## 1. GENERAL ABOUT CAPACITOR BANKS

Capacitor banks are normally used in medium voltage networks to generate reactive power to industries etc. Capacitor banks are, almost always, equipped with a series reactors to limit the inrush current (see fig. 1).

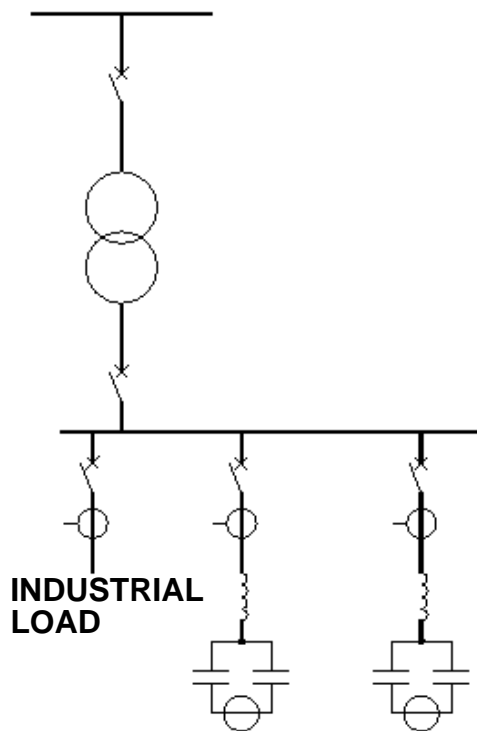

Figure 1. Capacitor banks with series reactors.

Harmonic filters, for thyristor controlled reactors, are also variations of capacitor banks having the reactor inductance together with the capacitor capacitance tuned for series resonance at a certain frequency. The tuning are purposely a little bit incorrect, in order not to get a too low impedance for the harmonic, to which it is tuned.

The capacitor banks usually are connected in double Y-connection with the neutral of the halves connected. The current between the two neutrals are supervised by an overcurrent (unbalance) relay.

---

## GENERAL ABOUT CAPACITOR BANKS

## 2. CAPACITOR BANK PROTECTION

### 2.1 UNBALANCE RELAY

This overcurrent relay detects an asymmetry in the capacitor bank caused by blown internal fuses, short-circuits across bushings, or between capacitor units and the racks in which they are mounted.

Each capacitor unit consist of a number of elements protected by internal fuses. Faulty elements in a capacitor unit are disconnected by the internal fuses. This causes overvoltages across the healthy capacitor units.

The capacitor units are designed to withstand 110% of the rated voltage continuously. If this level is exceeded, or if the faulty units capacitance have decreased below 5/6 of the nominal value, the capacitor bank must be taken out of service.

In normal service when all capacitor units are healthy the unbalance current is very small. With increasing number of blown internal fuses the unbalance current increases and the unbalance relay will give an alarm. The alarm level is normally set to 50% of the maximum permitted level. The capacitor bank then should be taken out of service to replace the faulty units. If not the capacitor bank will be tripped when the maximum allowed unbalance current level is exceeded.

### 2.2 CAPACITOR BANK OVERLOAD RELAY

Capacitors of today have very small losses and are therefore not subject to overload due to heating caused by overcurrent in the circuit.

Overload of capacitors are today mainly caused by overvoltages. It is the total peak voltage, the fundamental and the harmonic voltages together, that can cause overload of the capacitors. The capacitor can withstand 110% of rated voltage continuously. The

# Capacitor Protection

capability curve then follows an inverse time characteristic where withstand is approximately 1 second -180%, 10 cycles -210%.

Since the capacitors mostly are connected in series with a reactor it is not possible to detect overload by measuring the busbar voltage. This is because there is a voltage increase across the reactor and the harmonic currents causing overvoltages will not influence the busbar voltage.

ABB Transmit Oy have designed a relay that measures the current in the capacitor bank and transforms this into a voltage that corresponds to the voltage across the elements in the capacitor bank.

This relay is called SPAJ 160C and includes unbalance protection, overload protection and undercurrent relay. The undercurrent function is used to prevent the charged capacitor bank to be reconnected when a short loss of supply voltage occurs.

The connection of the relay is shown in fig. 2.

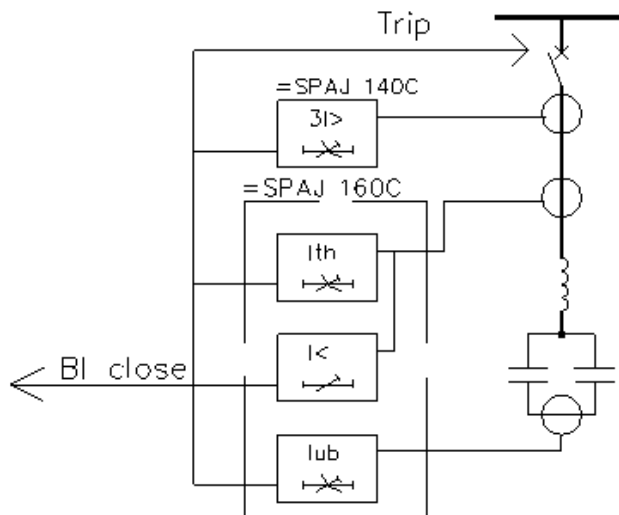

Figure 2. A SPAJ 160 connected to a capacitor bank.

---

## CAPACITOR BANK PROTECTION

## 2.3 SHORT-CIRCUIT PROTECTION

In addition to the relay functions described above the capacitor banks need to be protected against short circuits and earth faults. This is done with an ordinary two- or three-phase short circuit protection combined with an earth overcurrent relay.

# Bus&Breaker Protection

## 1. GENERAL ABOUT BUSBAR PROTECTION

A Busbar protection is a protection to protect Busbars at short-circuits and earth-faults. In the “childhood” of electricity no separate protection was used for the busbars. Nearby line protection were used as back-up for busbar protection.

With increasing short-circuit power in the network separate busbar protections have to be installed to limit the damage at primary faults. A delayed tripping for busbar faults can also lead to instability in nearby generators and total system collapse.

### 1.1 BUSBAR PROTECTION - REQUIREMENTS

Following requirements must be fulfilled. The Busbar protection:

- Must have as short tripping time as possible.
- Must be able to detect internal faults.
- Must be absolutely stable at external faults. External faults are much more common than internal faults. The magnitude of external faults can be equal to the stations maximum breaking capacity, while the function currents can go down to approximately 2% of the same. The stability factor therefor needs to be at least 50 times i. e. 20. CT-saturation at external faults must not lead to maloperation of the busbar protection.
- Must be able to detect and trip only the faulty part of the busbar system.
- Must be secure against maloperation due to auxiliary contact failure, human mistakes and faults in the secondary circuits etc.

### 1.2 TYPES OF BUSBAR PROTECTION

The busbar protections are mostly of differential type measuring the sum of current to all objects connected to the busbar, Kirchhoffs law.

Differential type of busbar protections can be divided into three different groups:

- low impedance.
- medium impedance.
- high impedance.

For metal enclosed distribution busbars, arc detectors also can be used as busbar protection. For systems that are only radial fed blockable overcurrent relays in the incoming bays can be used as busbar protection.

## **2. PRINCIPLES OF DIFFERENTIAL BUSBAR CONFIGURATIONS**

The simplest form of busbar protection is a 1-zone protection for single busbar configuration, see fig. 1. If the main CT:s have equal ratio auxiliary CT:s are not necessary.

If the busbar protection is of the high impedance type the main CT:s must have the same ratio and auxiliary CT:s may then not be used. Separate CT-core/s must also be supplied for the busbar protection.

Other protection relays must be connected to other CT-cores.

# Bus&Breaker Protection

For single busbar arrangement no switching is done in the CT-circuits and a check zone is therefore not necessary.

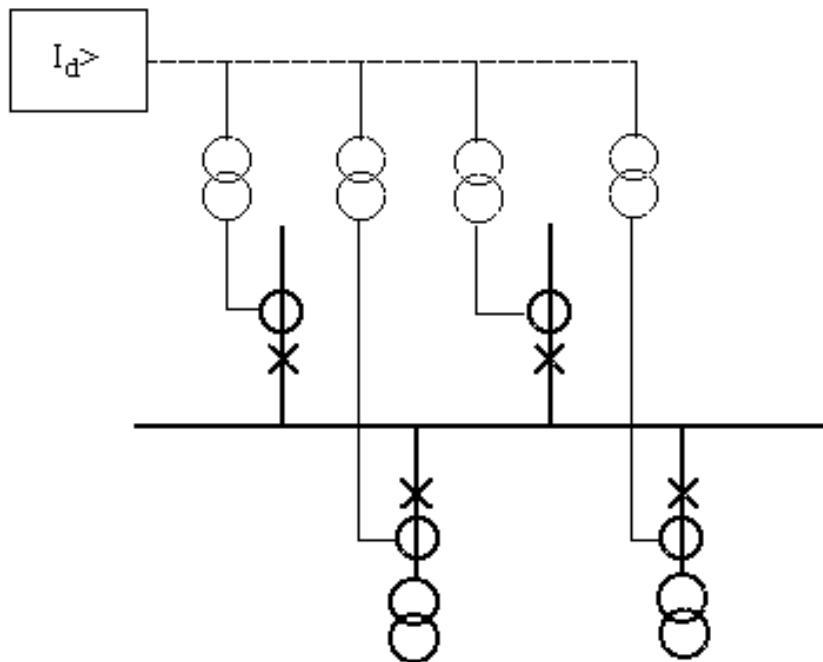

Figure 1. A one zone differential relay for a single busbar.

At 1 1/2-breakers system arrangements a 2-zone protection must be used se fig. 2.

If the main CT:s have equal ratio, which is normally the case, auxiliary CT:s are not necessary.

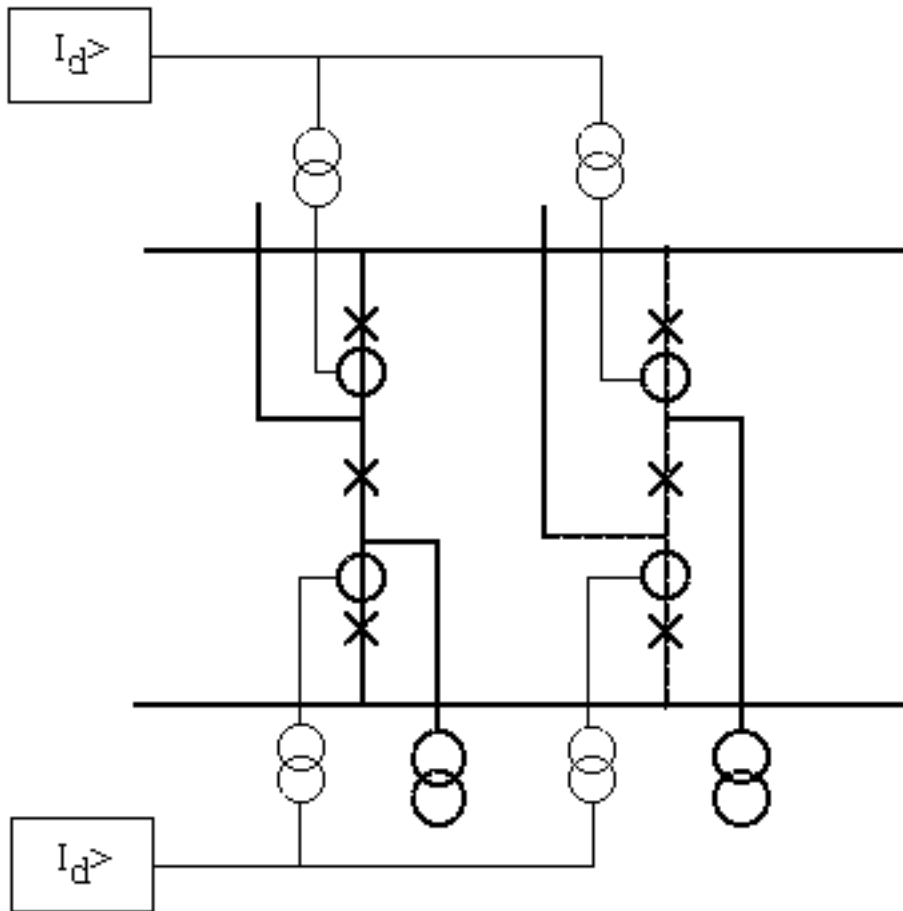

Figure 2. A two-zone busbar differential relay for 1 1/2-breaker switchgear

At double busbar switchgear a 2-zone protection shall be used, see fig. 3. If the main CT:s have equal ratio auxiliary CT:s are not necessary.

CT-circuits are switched depending on the position of the busbar disconnectors. The current is either connected to busbar A or busbar B:s differential protection. Switching is easiest performed by using repeat relays (RXMVB 2), controlled via two auxiliary contacts at each busbar disconnector, see fig. 5.



# Bus&Breaker Protection

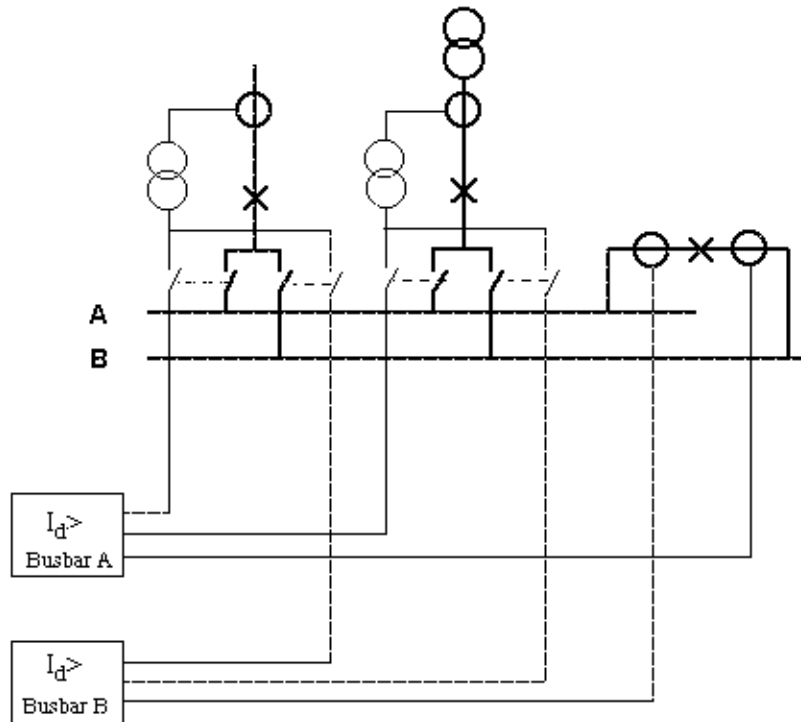

Figure 3. 2-zone busbar differential protection, for double busbar switchgear.

Many cases when switching in CT-circuit is done requires a check zone for the busbar protection, see fig. 4. The check zone is fixed and has no switching of CT:s in all outgoing circuits and is not connected at busbar sections and busbar couplers. Check zone, will detect faults anywhere in the substation but can not distinguish in what part of the substation the fault is located. When the check zone detects a fault it gives a release signal to the busbar protection relays in all individual, discriminating zones. The busbar protection discriminating zones will then trip the part of the substation that is faulty.

The releasing when the check zone detects a fault is normally done by sending out positive DC-voltage to the discriminating zones. Another way to do the releasing is to connect the negative DC-voltage to all trip relays from the check zone and to connect the positive DC-voltage from the discriminating zones.

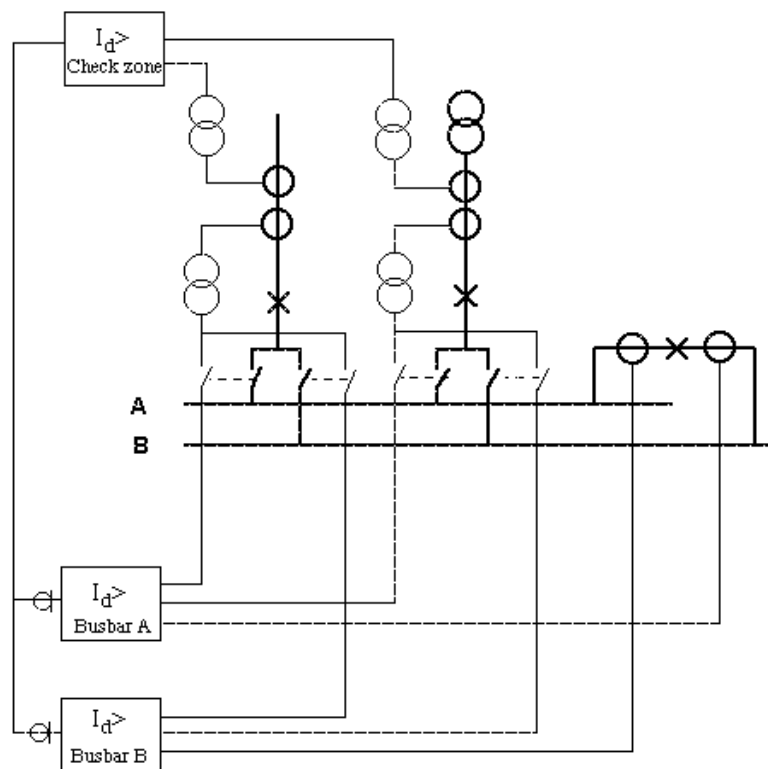

Figure 4. 2-zone busbar differential protection, for double busbar switchgear (including check zone), releasing the main zones for busbar A and B.

### 3. SWITCHING IN CURRENT CIRCUITS

For busbar systems, where the object can be connected to more than one busbar, double busbar systems, the current must be switched to the correct zone busbar protection. This switching must be done in such a way that no differential current develops in any of the busbar protections concerned. The switching is done by using two auxiliary contacts on the busbar disconnectors. These auxiliary contact are energizing throw-over relays (RXM-VB 2) which perform the switching in the CT-circuits. The disconnectors auxiliary contacts must be provided as in fig. 5.

Following requirements must be fulfilled by the auxiliary contacts “a” and “b” respectively:

---

#### SWITCHING IN CURRENT CIRCUITS

# Bus&Breaker Protection

- The auxiliary contact close minimum 100 ms before the main contact can start to carry current.
- The auxiliary contact “b” must open before the auxiliary contact “a” closes.
- The auxiliary contact “b” must not close before full insulation is secured (normally at 80% of the full insulation distance).

Main Contact	Open	Closed
Aux. Contact a	Open	Closed
Aux. Contact b	Closed	Open

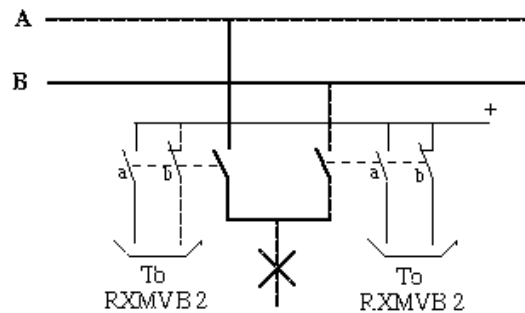

Figure 5. Requirements and connection of busbar disconnector auxiliary contacts, for switching of RXMVB 2 repeat relays.

## 4. PROTECTION OF MV BUSBARS IN DISTRIBUTION NETWORKS

For busbars in distribution networks Busbar protection can be achieved mainly in two different ways, either by blockable overcurrent protection at the incoming bays to the switchgear, or by locating arc detectors inside the enclosure.

Blockable overcurrent protection is based upon the principle that fault current is only fed by the incoming to the busbar. The incoming circuit is equipped with an overcurrent relay that have a fast step definite time-delay of approximately 100 ms (this step is

blocked if any of the overcurrent relays in the outgoing circuits starts, se fig. 6.

For metal enclosed busbars, arc detectors can be used as busbar protection. The arc at a primary fault is detected by a arc sensitive device, which trips all incoming circuit breakers. In order not to risk maloperation due to photographic flashes etc., it's advisable to also have an overcurrent interlock.

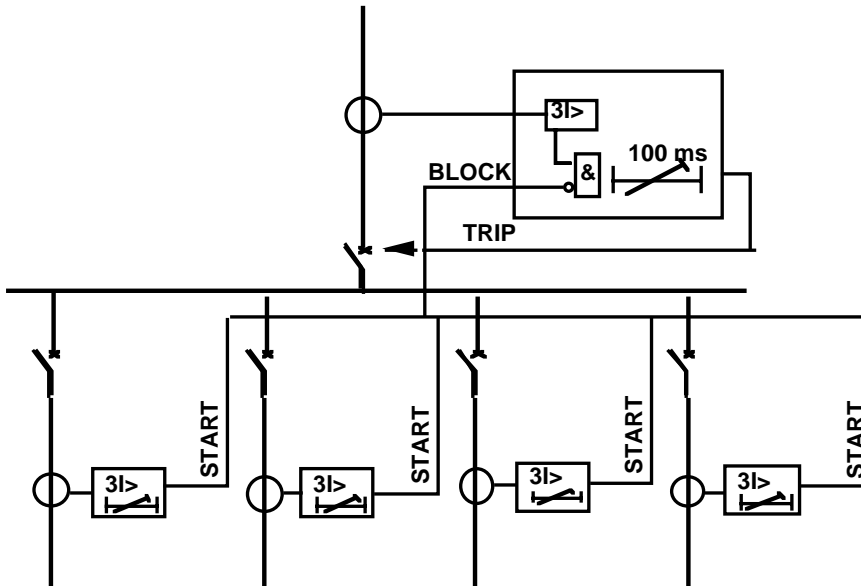

Figure 6. Blockable Overcurrent protection.

## 5. APPLICATION OF BUSBAR PROTECTION

Figure 7 gives a survey of different type of busbar protection

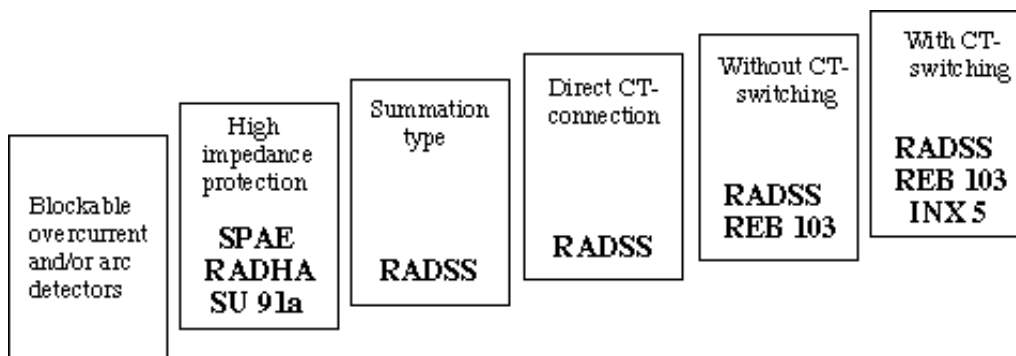

Figure 7. Application of different types of busbar protection relays

### APPLICATION OF BUSBAR PROTECTION

# Bus&Breaker Protection

For busbars in distribution networks the protection can be achieved mainly in two different ways. One way is by blockable overcurrent protection at the incoming bays to the switchgear another way is by locating arc detectors inside the enclosure.

High impedance protection needs separate CT-cores with equal ratio at each feeder, bus-coupler and bus-section. This means that other protection relays cannot be connected to the same CT-core. This type of busbar protection is mainly for medium voltage levels.

**RADSC** is a new type of low impedance busbar protection that can be used as an alternative to high impedance protection relays. It has a maximum of 6 inputs and can therefore not be used in larger substations. It can however use the same CT-cores as other protection relays but requires auxiliary CT:s if the main CT:s in the different bays have different ratio.

Summation type of busbar protection can be used for more economical variants of protection. The Summation type Busbar protection relays has only one measuring unit which means that there is no internal back-up for 2-phase and 3-phase faults. Primary operating current varies with a factor 4 depending on in which phase the fault occurs. Phase indication cannot be obtained.

**RADSS and REB 103** are medium impedance type of busbar protection relays, during internal faults, but low impedance protection during load and external faults. RADSS and REB 103 can therefor be used together with other types of object protection on the same cores. This kind of protection is intended for high (HV) and extra high voltage (EHV) levels.

RADSS can be used without auxiliary CT:s if the main CT:s have equal ratio. This gives a solution that is both economical and saves space. The only restraint is that the maximum circulating current through RADSS, power transferred through the zone, must not exceed 4 A secondary. This could be a problem if the

---

## APPLICATION OF BUSBAR PROTECTION

main CT:s both have 5 A secondary but can be overcome by increasing the primary ratio of the main CT:s.

When main CT:s have different ratio REB 103 gives a more economic solution since REB 103 is designed with auxiliary CT:s of small physical sizes. REB 103 cannot be used without auxiliary CT:s.

INX 5 is a low impedance busbar protection for high (HV), and extra high voltage (EHV) levels.

REB 500 is a new decentralized, or centralized, numerical Busbar protection relay with a process bus connecting the different bays. The relay is mainly intended for the HV and EHV voltages.

## **6. BREAKER FAILURE RELAYS**

In order to take care of possible breaker failure, Circuit Breaker Failure relays normally are installed in high voltage, and extra high voltage systems.

All protection tripping (not manual opening) will start a current relay measuring the current through the CB. If the current has not disappeared within the set time, all adjacent CB:s will be tripped to clear the fault.

---

### **BREAKER FAILURE RELAYS**

# Bus&Breaker Protection

The time “split up” at a normal tripping and a breaker failure tripping is shown in fig. 8.

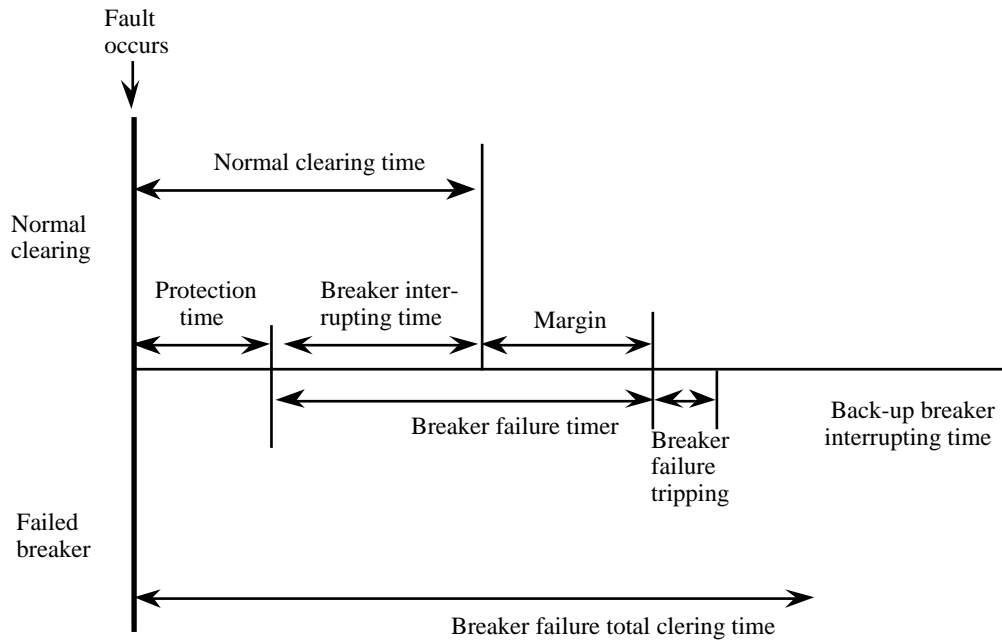

Figure 8. Time scheme for breaker failure relays

In normal cases the total fault clearing time will be the protection relay operating time plus the CB interrupting time. Every time a relay gives a trip order it will at the same time start the Circuit Breaker Failure (CBF) relay. The CBF-timer will be running as long as the current is flowing through the CB. When the CB interrupts the current the CBF-current relay will reset and the CBF-timer will stop.

---

## BREAKER FAILURE RELAYS

The setting of the CBF-timer must be:

***maximum interrupting time of the ordinary CB, plus the reset time of the CBF-current relay, plus the impulse margin time of the CBF-timer, plus a margin.***

With “impulse margin time” is meant the difference between set time and the time “to no return”. If the timer is set to 100 ms and is fed during, lets say 98 ms, it will continue to operate since the margin between the set time and the actual time is small. The margin should be chosen to at least 50-60 ms to minimize the risk of unnecessary tripping, specially considering the heavy impact on the network a CBF tripping will cause.

## 7. POLE DISCORDANCE RELAYS

For circuit breakers with one operating device per pole, it is necessary to supervise that all three phases have the same position.

This is normally done by using the auxiliary contacts on the circuit breaker according to figure 9.

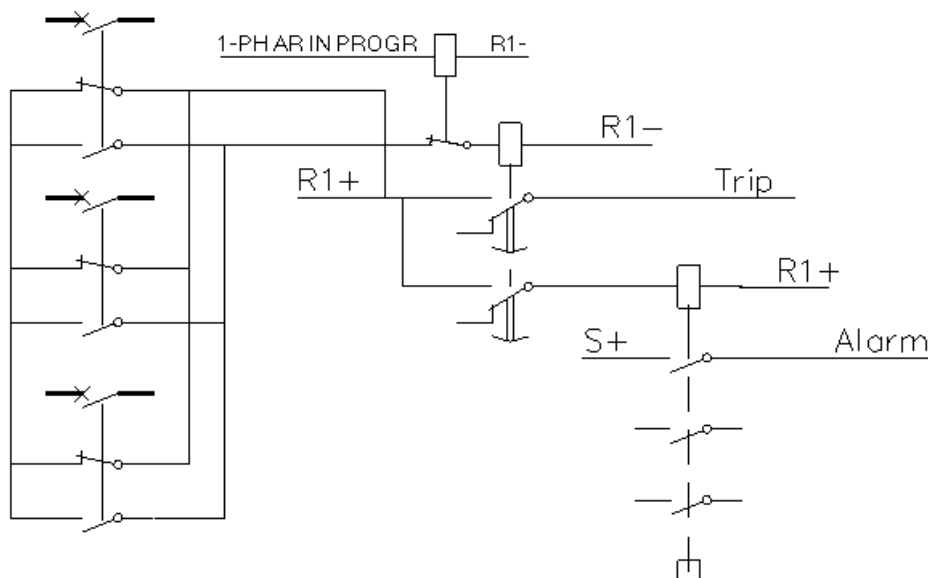

Figure 9. Connection of a Pole Discordance relay.

---

### POLE DISCORDANCE RELAYS



# Bus & Breaker Protection

Pole discordance relay “**PD**” is necessary to prevent service with only one or two phases of a circuit breaker closed. This will cause an unsymmetry that can lead to damage of other apparatus in the network. Unsymmetrical conditions can only be accepted during a single pole Auto reclosing cycle.

When single pole Auto reclosing is used a blocking of the PD is necessary during the single phase dead time, see figure 9.

The timing sequence at closing and opening of breakers and the timing of the operation at a pole discrepancy tripping must be checked carefully. It is e. g. often necessary to operate the flag relay first and the tripping from this relay to achieve correct indication at a trip as the main contacts will rather fast take away the actuating quantity when the remaining poles are opened.

Tripping from PD should be routed to other trip coil than the one used by manual opening. This is due to the fact that at manual opening there could be an incipient fault in the circuit. This incipient fault could result in that only one or two phases operate and the MCB for the circuit is tripped. PD would thus not be able to operate if connected to the same coil as manual opening.

Operation of PD shall in addition to tripping the own circuit breaker start Circuit Breaker failure relay, lock-out the own circuit breaker and give an alarm.

A normal time delay for a PD relay should be approximately 150-200 ms when blocking during single pole Auto reclose is performed. If not the necessary time is about 1,2 sec.

Note: Some customers do not rely only on the auxiliary contacts and want to detect Pole discordance also by measuring the residual current through the breaker at breaker for some second at opening and closing.

We have however good experience of the contact based principle and recommend only this simple principle.

Residual current measurement at closing and opening is not a reliable function either as there is no load current when a line is closed from one end only and on the other hand normal residual

---

## POLE DISCORDANCE RELAYS

currents can occur if the closing is onto a fault or e. g. energizes a transformer at the far end of the system.

Conclusion is to use a simple contact based Pole Discordance function which is simple and reliable. The residual current based principle is more complicated and can give difficulties in setting of sensitivity etc.

---

## POLE DISCORDANCE RELAYS

# Earth Fault Protection

## 1. INTRODUCTION

The fault statistic shows that earth faults are the dominating fault type and therefore the earth fault protection is of main importance in a network.

The type of earth fault protection used is dependent of the system earthing principle used. In the following the earth fault protection for solidly- (effectively), reactance-, high resistive- and resonance earthed systems are covered.

## 2. EFFECTIVELY EARTHED SYSTEMS

In the effectively earthed systems all transformers are normally connected to earth and will thus feed earth fault current to the fault. The contribution from all earthing locations gives special requirements for the protection system.

### 2.1 FAULT RESISTANCE AND FAULT CURRENT LEVELS

In order to calculate fault currents in an effectively earthed system we must use the representation with symmetrical components.

The symmetrical component scheme for a 132 kV system with a fault according to Figure 1 is shown in Figure 2.

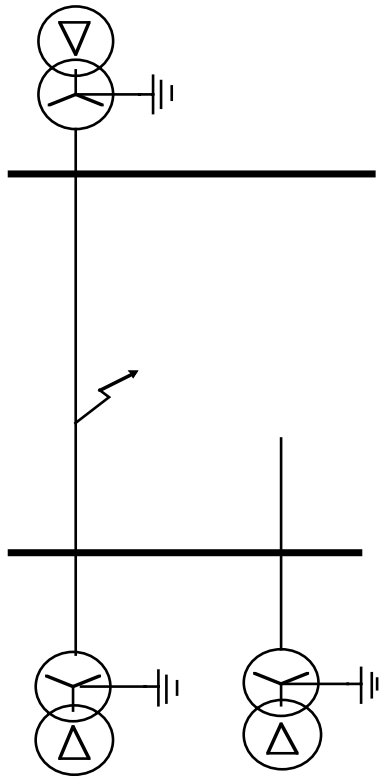

Figure 1. An earth fault in a direct, effectively earthed system.

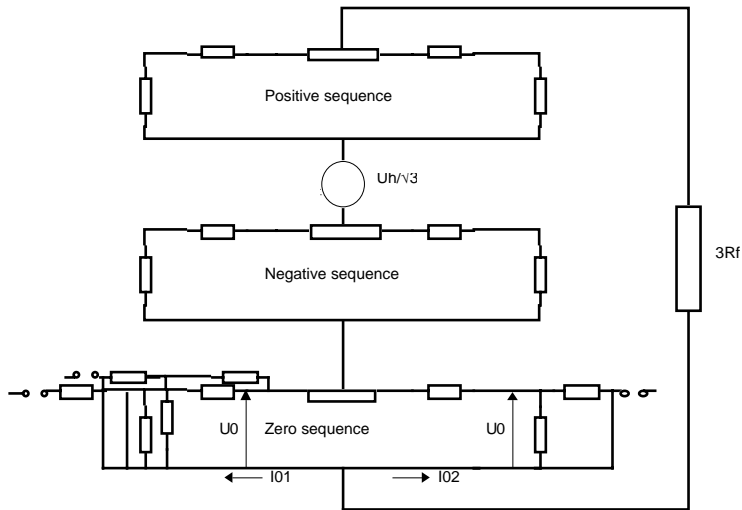

Figure 2. The symmetrical components are used to calculate the " $I_0$ " current for the fault in figure 1, " $3I_0$ " is the total fault current.

The distribution of fault currents, from the different system earthing points, can be derived from the distribution in the zero sequence network (see figure 2). By inserting varying fault resistances one can get the fault current level.

---

## EFFECTIVELY EARTHED SYSTEMS

# Earth Fault Protection

The fault resistance “ $R_f$ ”, consists of the arc resistance and the tower foot resistance. The arc resistance is calculated by the formula:

$$R_{\text{arc}} = 28700a / I_f^{1.4} \quad (\text{according to Warrington})$$

where “ $a$ ”, is the arc length in meter, normally the insulator length, and “ $I_f$ ” is the fault current in “ $A$ ”.

A calculation will show that values will differ from below 1  $\Omega$  for heavy faults, up to 50-400  $\Omega$  for high resistive earth faults.

The tower foot resistance depends on the earthing effectiveness of the towers, whether top lines are used etc. For the tower foot resistance values from below 10  $\Omega$  up to 50  $\Omega$  have been documented.

## 2.2 NEUTRAL POINT VOLTAGES

The occurring neutral point voltage, at different locations, can be seen in figure 2. The designate “ $U_0$ ”, represents the neutral point voltage ( $3U_0 = U_N$ ). It's to be noted that “ $U_0$ ” is generated by the earth fault current “ $I_0$ ” through the zero sequence source. This implies that the angle between “ $U_0$ ” and “ $I_0$ ” is always equal to the zero sequence source angle, independent of the fault resistance and the angle between the faulty phase voltage and the line current in the faulty phase.

It must also be noted that “ $U_N$ ” will be very low when sensitive earth fault relays are used in a strong network with low zero sequence source impedances.

As an example we can use the 132kV network according to figure 1 and 2. With an “ $I_N$ ” setting of 120A, the “ $I_0$ ” is 40A and with a zero sequence source impedance of say 20  $\Omega$ , the zero sequence voltage component “ $U_0$ ” will be  $40 \times 10 = 400V$  and “ $3U_0$ ” will then be 1200V. This will, with an open delta winding with 110V

---

### EFFECTIVELY EARTHED SYSTEMS

secondary, mean a percentage voltage of 1.6%, i.e. the polarizing sensitivity of directional earth fault relays must be high.

In an open delta secondary circuit there is a voltage also during normal service due to unbalances in the network. The voltage is mainly of third harmonic and of size 0,2-0,5% with conventional VT:s and 1-3% together with CVT:s.

This means that the sensitive directional earth fault protection must be provided with a third harmonic filter when used together with CVT:s. The filtering must be quite heavy to ensure correct directional measuring for 1% fundamental content also with third harmonic contents of say 3%.

## **2.3 RESTRICTED EARTH FAULT PROTECTION (REF).**

For solidly earthed systems a restricted earth fault protection is often provided as a complement to the normal transformer differential relay. The advantage with the restricted earth fault relays is their high sensitivity. Sensitivities of 2-8% can be achieved. The level is dependent of the current transformers magnetizing currents whereas the normal differential relay will have sensitivities of 20-40%.

Restricted earth fault relays are also very quick due to the simple measuring principle and the measurement of one winding only. The differential relay requires percentage through fault and second harmonic inrush stabilization which always will limit the minimum operating time.

# Earth Fault Protection

The connection of a restricted earth fault relay is shown in Figure 3. It is connected across each transformer winding in the figure.

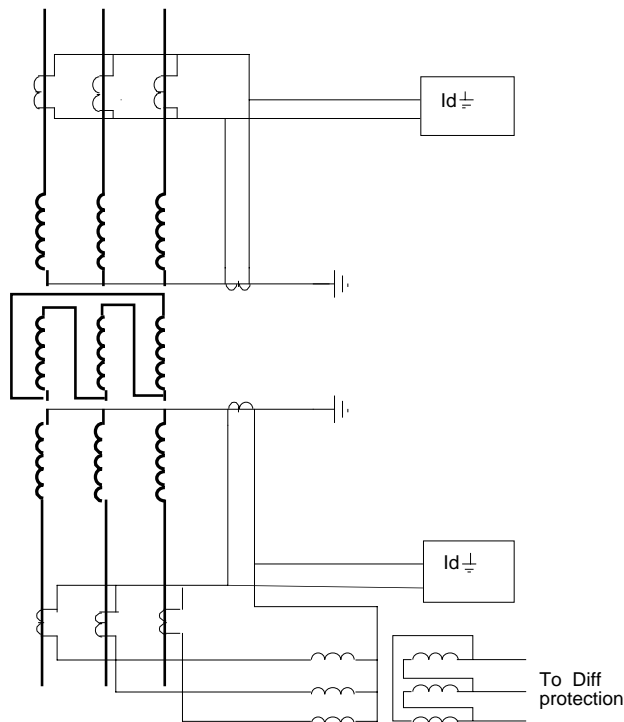
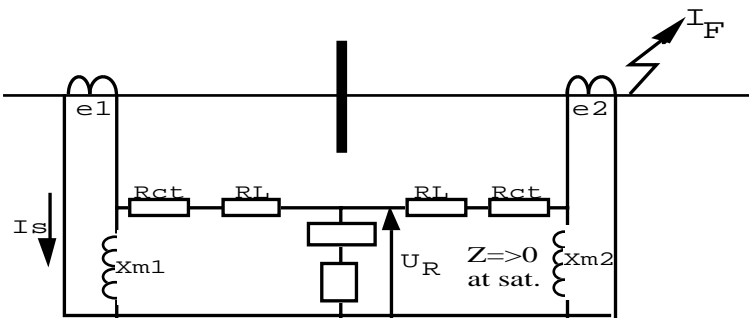

Figure 3. A restricted earth fault relay for an YNdyn transformer.

It is quite common to connect the Restricted earth fault relay in the same current circuit as the transformer differential relay. This will due to the differences in measuring principle limit the differential relays possibility to detect earth faults. Such faults are detected by the REF. The mixed connection is shown in the low voltage winding of the transformer, see figure 3.

The common principle for Restricted earth fault relays is the high impedance principle, see figure 4.



Secondary current and voltage with no voltage limiter.

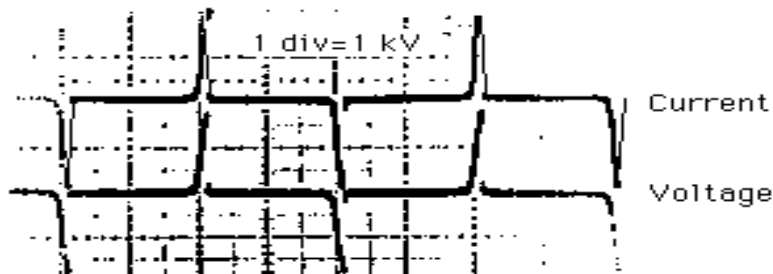

Figure 4. The high impedance principle.

The relay provides a high impedance to the current. The current will, for through loads and through faults, circulate in the current transformer circuits, not go through the relay.

For a through fault one current transformer might saturate when the other still will feed current. For such a case a voltage can be achieved across the relay. The calculations are made with the worst situations in mind and an operating voltage “ $U_R$ ” is calculated:

$$U_R \geq I_{Fmax}(R_{ct} + R_l)$$

where

“ $I_{Fmax}$ ” is the maximum through fault current at the secondary side,

“ $R_{ct}$ ” is the current transformer secondary resistance and

“ $R_l$ ” is the loop resistance of the circuit.

---

## EFFECTIVELY EARTHED SYSTEMS



# Earth Fault Protection

The maximum operating voltage have to be calculated (both neutral loop and phase loop must be checked) and the relay set higher than the highest achieved value.

For an internal fault the circulation is not possible and due to the high impedance the current transformers will immediately saturate and a rms voltage with the size of current transformer saturation voltage will be achieved across the relay. Due to the fast saturation very high top voltages can be achieved. To prevent the risk of flashover in the circuit, a voltage limiter must be included. The voltage limiter can be either of type surge arrester or voltage dependent resistor.

The relay sensitivity is decided by the total current in the circuit according to the formula:

$$I_p \geq n(I_R + I_{res} + \Sigma I_{mag})$$

where “n” is the CT ratio, “ $I_R$ ” is the current through the relay, “ $I_{res}$ ” is the current through the voltage limiter and “ $\Sigma I_{mag}$ ” is the sum of the magnetizing currents from all CT’s in the circuit (normally 4).

It should be remembered that the vectorial sum of the currents must be used. The current measurement have to be DC insensitive to allow a use of AC components of the fault current in the calculations.

## 2.4 LOGARITMIC INVERSE RELAY

Detection of earth fault and back-up tripping with maintained selectivity in a solidly (effectively) earthed system is rather complicated due to the infeed of fault current from different direction concerning all faults. A special inverse characteristic with a logarithmic curve has been developed to be suitable for these applications. The principle for earth fault relays in a effectively earthed system is shown in figure 5 and the logarithmic inverse characteristic is shown in figure 6. The inverse characteristic is selected so

---

### EFFECTIVELY EARTHED SYSTEMS

that if the current of the largest infeed is less than 80% of the faulty objects current selectivity is achieved.

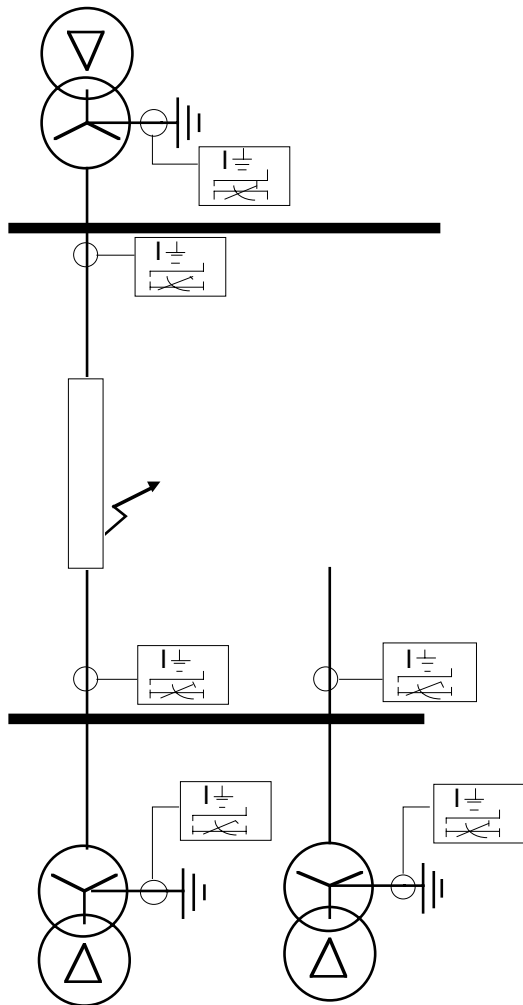

Figure 5. Earth fault protection in a solidly earthed system.

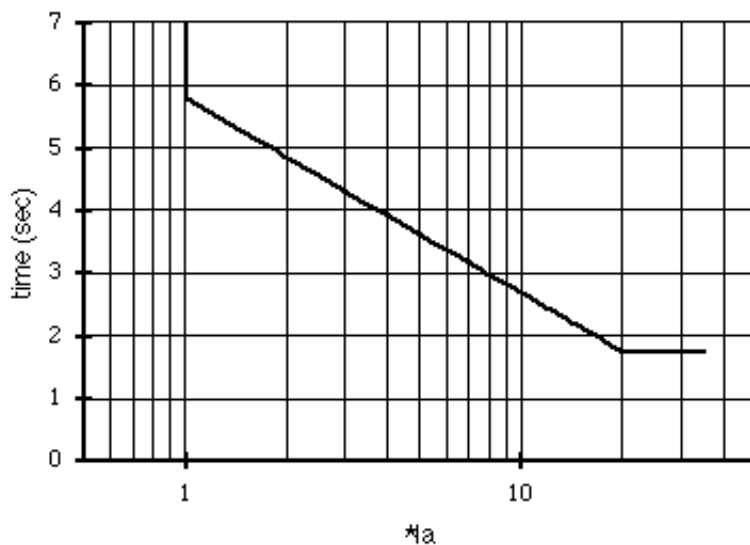

Figure 6. The logarithmic inverse characteristic. A fault current of the biggest infeed less than 0,8 times the current of the faulty object, gives a selective tripping.

## EFFECTIVELY EARTHED SYSTEMS

# Earth Fault Protection

To enable use together with Distance protection giving single-phase tripping a definite minimum time is set (normally 0.3 sec.). This ensures that a single phase tripping for heavy single phase faults can be done by distance protection relay first.

## 2.5 DIRECTIONAL COMPARISON SCHEMES.

To provide detection of high resistance earth faults in an effectively earthed network it's common to use a directional comparison scheme with directional earth fault relays at both ends of the power line. The relays at the two ends are directed towards each other and a communication between the relays, through a power line carrier (PLC) or a radio link, is introduced.

### Principle for communication schemes

Communication can be made according to two main principles:

- permissive scheme
- blocking scheme

In a **permissive scheme** the Directional earth fault relays will send a signal (CS) to the remote end at detection of a forward fault. At reception of a signal and detection of a forward fault at the receiving end, an instantaneous trip is given. Normally the same situation occurs at both ends. A permissive scheme principle is shown in Figure 7.

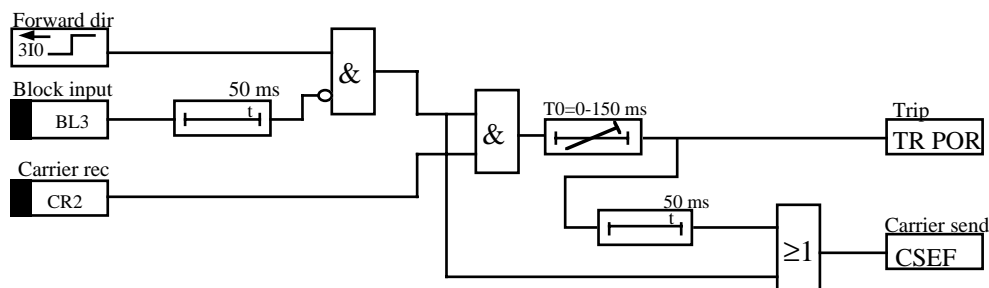

Figure 7. A permissive overreaching scheme (POR) with directional earth fault relays.

In a **blocking scheme** the directional earth fault relays are provided with a reverse locking element as a complement to the forward element. The reversed element is set to be more sensitive

---

## EFFECTIVELY EARTHED SYSTEMS

than the forward element and will, when a reverse fault is detected, send a signal (CS), to the remote end. At the remote end the forward element is provided with a short time delay " $T_0$ " normally set to 50-150 ms, to check if a blocking signal is received. If not, the relay will trip. The same situation will for internal faults occur at both line ends. The principle of a blocking scheme is shown in Figure 8.

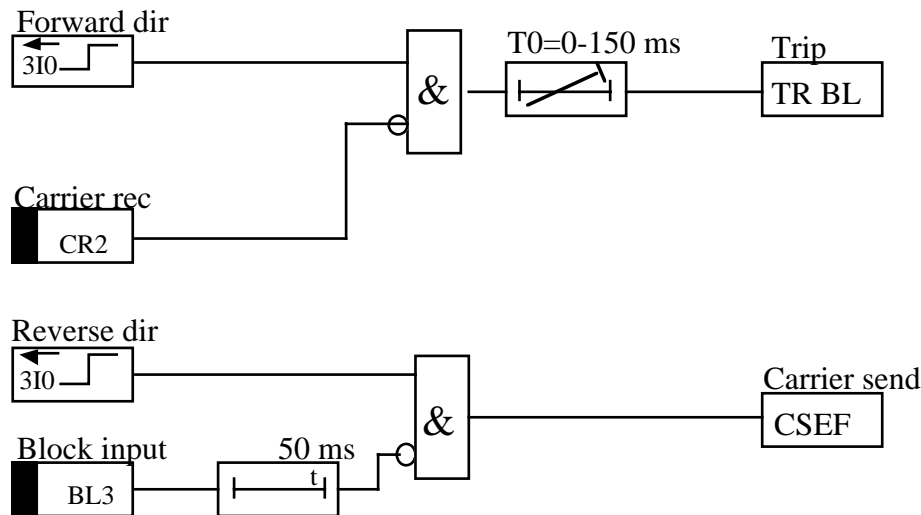

Figure 8. A blocking scheme with directional earth fault relays.

In most cases the Directional earth fault relays in a communication scheme also includes a communication independent back-up tripping with a time delay. Inverse or definite time delay can be used. Normally the inverse characteristic and the logarithmic inverse characteristic gives the best possibility to achieve time selectivity also at back-up tripping.

### Single phase tripping.

When Distance protection relays with single phase tripping and auto reclosing are used at the same line as a scheme with earth fault relays it must be ensured that the Distance protection relays are allowed to give their single-phase tripping first. Earth fault relays must therefore be time delayed to allow this. This is also valid when communication schemes are used. A blocking of the earth fault scheme at distance protection operation is often used to enable use of short time delays in the communicating earth fault relays.

During a single phase trip an unbalance in the complete network occurs and an earth fault currents flows through the network.

---

## EFFECTIVELY EARTHED SYSTEMS

# Earth Fault Protection

These currents reaches levels up to 20% of the load current and an unnecessary tripping from earth fault relays can therefor be achieved. The earth fault relays are normally blocked during the single phase auto reclose cycle.

## Current reversal

A special application problem occurs together with directional earth fault schemes communicating in a POR scheme. The problem is fault current reversal which occurs when the CB at one end of the faulty line trips before the breaker at the other end. The fault current changes direction in the parallel line and a timing problem to prevent maloperation at the end with a CS signal receipt at the original fault occurring will occur (see figure 9). A special logic according to Figure 10 is required to prevent a unnecessary function.

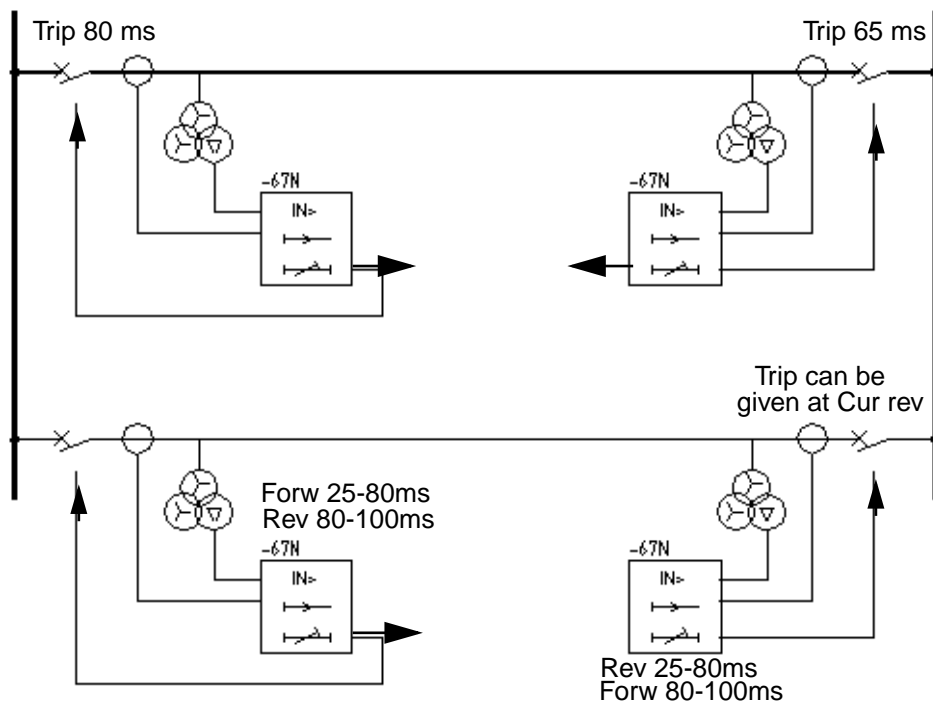
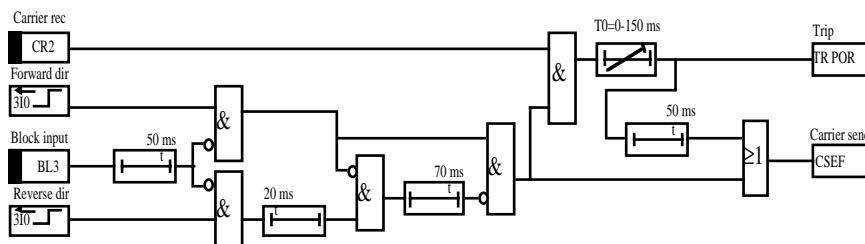

Figure 9. The current reversal problem at parallel lines.



## EFFECTIVELY EARTHED SYSTEMS

Figure 10. A logic in directional earth fault relays, to prevent unnecessary operation during current reversal.

### **Weak-end infeed**

In special applications, a situation where the fault current infeed from one end isn't ensured during certain service conditions.

A special weak end infeed logic can be used together with POR schemes. It is based on occurring zero sequence voltage and the receipt of a carrier signal CS from the remote (strong) end. The logic for an earth fault weak-end infeed function includes a check of occurring  $U_N$  voltage at carrier receipt and the breaker is tripped even if no operation of DEF relay is achieved due to a weak source. It is also necessary to "mirror" the Carrier signal back so the signal is sent back on receipt if the  $U_N$  voltage is low, or if the circuit breaker is open.

## **2.6 INRUSH CURRENT STABILIZATION**

In some countries a second harmonic stabilization is required for sensitive earth fault relays. The background to this is that the inrush currents occurring at transformer energizing which, in some networks has long durations. The long durations are often achieved in weak networks. The second harmonic stabilization can then block the earth fault relay, during the inrush and prevent the risk of an unnecessary operation.

It should be noted that a POR communication scheme can not operate for inrush currents as only one end will have conditions fulfilled whereas the other end has a blocking condition.

For inverse time delayed scheme a time setting is selected to achieve selectivity to instantaneous protection. This gives a long delay compared to normal inrush times and the inverse characteristic will then match the decay of the inrush current and keep the relay away from unwanted functions.

The only time when a stabilization is necessary is when very sensitive definite time delayed relays are used. In such cases the inrush can cross the corner with minimum current before the time elapses and an unwanted function can occur.

---

### **EFFECTIVELY EARTHED SYSTEMS**

# Earth Fault Protection

## 3. REACTANCE EARTHED SYSTEMS

The earth fault protection in a reactance earthed system is made with a simple design as the generation of fault current comes from the source side of the network only. The earthing is made at the feeding transformer or at the busbar through a Z-0 earthing transformer.

### 3.1 Z-0 EARTHING TRANSFORMER.

The earthing transformer is selected to give an earth fault current with a well defined level. Normally the selected current is 750 to 1500A. The Z-0 (zig zag) transformer principle is shown in Figure 11.

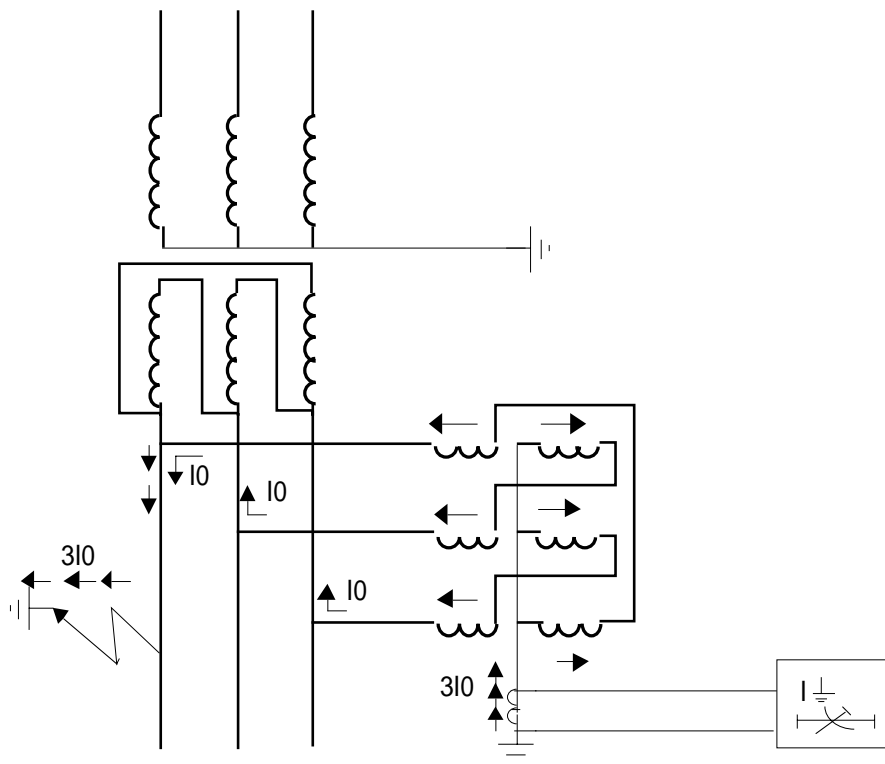

Figure 11. The principle of a Zig-zag transformer providing earth fault current in a reactance earthed system.

## REACTANCE EARTHED SYSTEMS

The reactance is selected to give the fault current. It must be remembered that the zero sequence reactance in  $\Omega$ /phase is three times the reactance calculated by the formula:

$$3I_0 \text{ i. e. } I_N = 1000\text{A} = \frac{U_n}{\sqrt{3} \times Z_N}$$

respectively

$$\frac{U_n}{\sqrt{3} \times I_N} = Z_N$$

This means that, for a 20kV system with a 1000A earthing the Z-0 transformer shall be selected with a zero sequence reactance.

$$X_0 = \frac{20}{\sqrt{3}} 1000 = 11.6 \Rightarrow \text{Select } 35\Omega/\text{phase}$$

A Z-0 transformer can often be provided with an auxiliary power supply winding with a 400V secondary. This is possible up to 800-1000kVA and the protection system have to be checked so that the proper fault protection of the low voltage side of the auxiliary transformer is achieved. One solution is to use delta connected short circuit protection at the HV side (Z-0 winding).

Fuses and breakers placed at the HV side of a Z-0 transformer should be avoided as the network earthing then can be disconnected and the risk of earth fault trips disappears. It will also involve a risk of arcing faults and of ferro resonance in the voltage transformers.

## 3.2 FAULT RESISTANCE AND FAULT CURRENT LEVELS

In a reactance earthed system the current still is quite high. The fault resistance will therefore decrease and a beginning fault will, rather quickly, develop into a fault situation.

The fault current level will be quite independent of the fault position. If a reactance earthing with 1000 A is used in a 20 kV system, the apparent neutral reactance will be 12  $\Omega$ . This means that a reactance to the fault, through a line of 12  $\Omega$ , will make the fault

---

### REACTANCE EARTHED SYSTEMS



# Earth Fault Protection

current level half ( $12 \Omega$  will be the reactance of a 30k m line in a 50 Hz system).

If a fault resistance is introduced the resistance will add vectorial to the reactance and the current will change slowly with the fault resistance.

## 3.3 NEUTRAL POINT VOLTAGES.

The neutral point voltage is calculated in the same way as the source impedance (i.e.  $Z_n (1/3Z_0) \times I_f$ ). This means that for a fully developed earth fault full neutral displacement occurs and a fault current of 20% e.g. 200 A in a 1000 A earthed system will be 20% of " $U_n$ ".

## 3.4 RESTRICTED EARTH FAULT PROTECTION.

A Restricted earth fault protection REF can not be justified in a reactance earthed system in the same way as in a directly (effectively) earthed system. This is because the fault current is much lower and by that also the occurring damage which is dependent of the " $I^2t$ " condition.

However in many countries REF protection relays are specified also in reactance earthed systems the connection of a REF relay is shown in Figure 12.

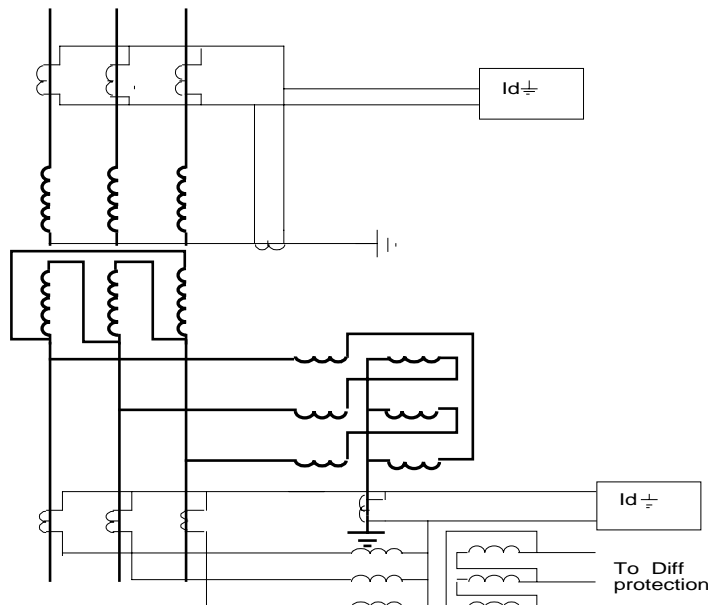

Figure 12. A Restricted earth fault relay in a reactance earthed system with a Z-0 transformer.

The application is fully possible but it must be ensured that a high sensitivity is achieved. Operation values of 5-10% of the maximum earth fault current generated is required.

When the operating voltage of the REF is calculated the check of required operating value must be done by first checking the earth fault loops for phase CT:s and neutral CT:s. However, as the maximum through fault current is limited by the reactance a check of the occurring loop at phase faults must be performed. The unbalanced voltage is caused by one phase CT which is saturated and the other is not. This can be caused by, for example, the DC components at fault current which is not equal between the phases. This check will often set the required operating voltage as the fault current at phase faults is much higher. It is advantageous to summate the three CT:s as close to the current transformers as possible. This can sometimes be difficult because of the transformer differential relay and its interposing CT's are located in the same circuit.

---

## REACTANCE EARTHED SYSTEMS

# Earth Fault Protection

## 3.5 EARTH FAULT PROTECTION.

The earth fault protection in a reactance earthed system is normally provided with time delayed simple and unidirectional earth fault current measuring relays.

Time grading of the protection, furthest out in the system to the protection in the neutral of the zig-zag transformer is used. The time delay can be with normal inverse, or definite time delay. A solution with inverse time delayed relay is shown in figure 13.

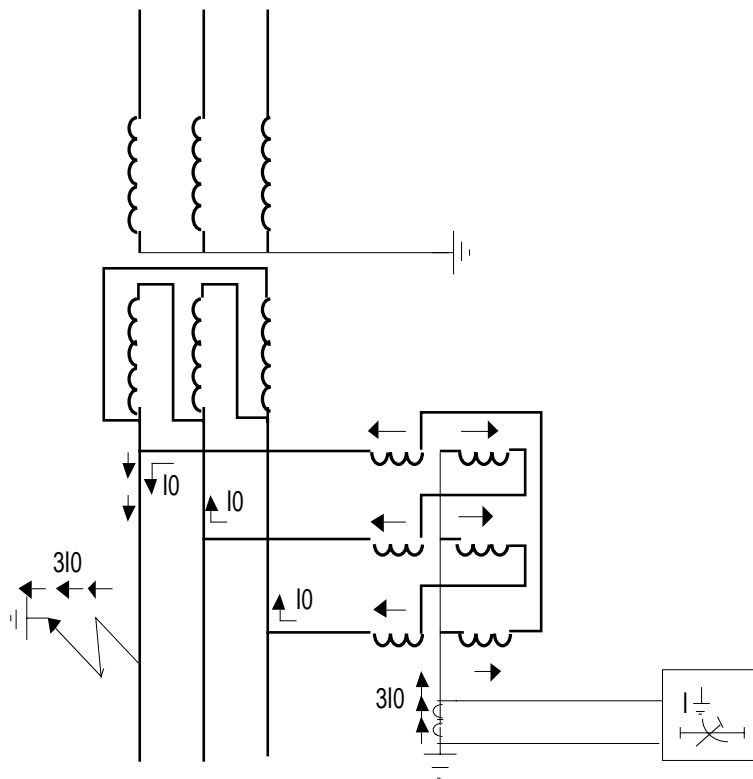

Figure 13. An earth fault protection system for a reactance earthed network where selectivity is achieved by inverse time delayed relays.

## 4. HIGH RESISTANCE EARTHED SYSTEMS

### 4.1 PRINCIPLE

The high resistance earthed networks are earthed at the source side of the network only. Normally the earthing is restricted to one point only and an arrangement is provided to allow varying connection possibilities of the earthing point due to the service conditions (see figure 14).

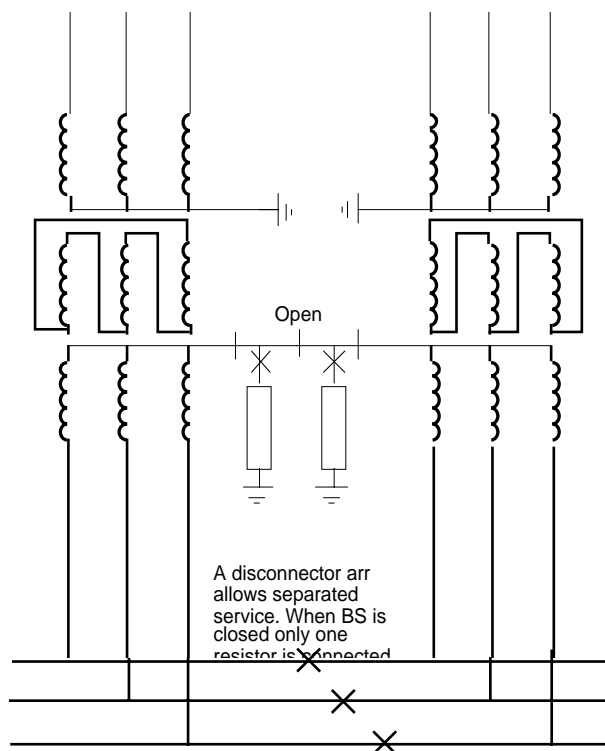

Figure 14. A high resistance earthed network and a selection of service conditions with disconnectors.

### 4.2 FAULT RESISTANCE AND FAULT CURRENT LEVELS.

The earthing resistor is mostly set to give an earth fault current of 5-15A. The trend to decrease the current level gives lower requirement of earthing grid and higher neutral point voltages at high resistive earth faults.

---

#### HIGH RESISTANCE EARTHED SYSTEMS

# Earth Fault Protection

Due to the low current magnitude, high resistance earth faults will not quickly develop to lower resistance so a high fault resistance need to be detected. In Sweden a fault resistance of 5000  $\Omega$  must be detected for some types of overhead lines. In order to detect such high values it is often necessary to use a resonance earthing in order to achieve reasonable high neutral point voltages. (>5V at 5000  $\Omega$ ).

Due to the high sensitivity required it's required to use cable current transformers surrounding the three phases to do the measuring. The current transformer is then selected with a suitable ratio independent of load current and no current will flow during normal services. A sensitivity down to 1-2A primary is required at high resistance earthed systems.

## 4.3 NEUTRAL POINT VOLTAGES.

In order to detect high values of fault resistance up to 5000  $\Omega$  it's often necessary to use a resonance earthing to achieve acceptable high neutral point voltages (>5V at 5000 $\Omega$ ). The neutral point voltage is required to give the directional criteria for the directional earth fault protection and is also used to provide a back-up earth fault protection at the busbar or the transformer bay.

A small neutral point voltage exists, during normal service of the network due to unsymmetrical capacitance of the phases to earth and the resistive current leakage at apparatus such as surge arresters. Normally the occurring levels of unbalance currents is 0,2 - 5%. Neutral point detection relays and directional relays should therefor never be allowed to have sensitivities below 5-10% to compare with the requirements of very low levels in solidly earthed systems.

The neutral point voltages are calculated with the fault resistance " $R_f$ " in series with the neutral reactance " $Z_N$ ". The neutral impedance consists of the earthing resistance " $R_N$ " and the capacitive

---

### HIGH RESISTANCE EARTHED SYSTEMS

reactance of the network " $X_C$ ". The factor " $R_f/R_f + Z_N$ ", gives the occurring, per unit, voltage.

The " $Z_N$ " impedance can be calculated " $U_n/(\sqrt{3} \times I_f)$ ", where  $I_f$  is the total fault current.

It must be remembered that " $Z_N$ ", as well as the vectorial sum have to be calculated.

#### **4.4 DIRECTIONAL EARTH FAULT PROTECTION**

Due to the infeed of capacitive currents from healthy objects during an earth fault it's usually required to use directional earth fault relays. Directional relays are used when the infeed of capacitive current from an object during a fault in an other object is higher than 60% of the required sensitivity.

The directional relays will measure the active component of the fault current only, i. e. the current generated by the earthing resistance. The principle for fault current and capacitive current generation is shown in Figure 15.

# Earth Fault Protection

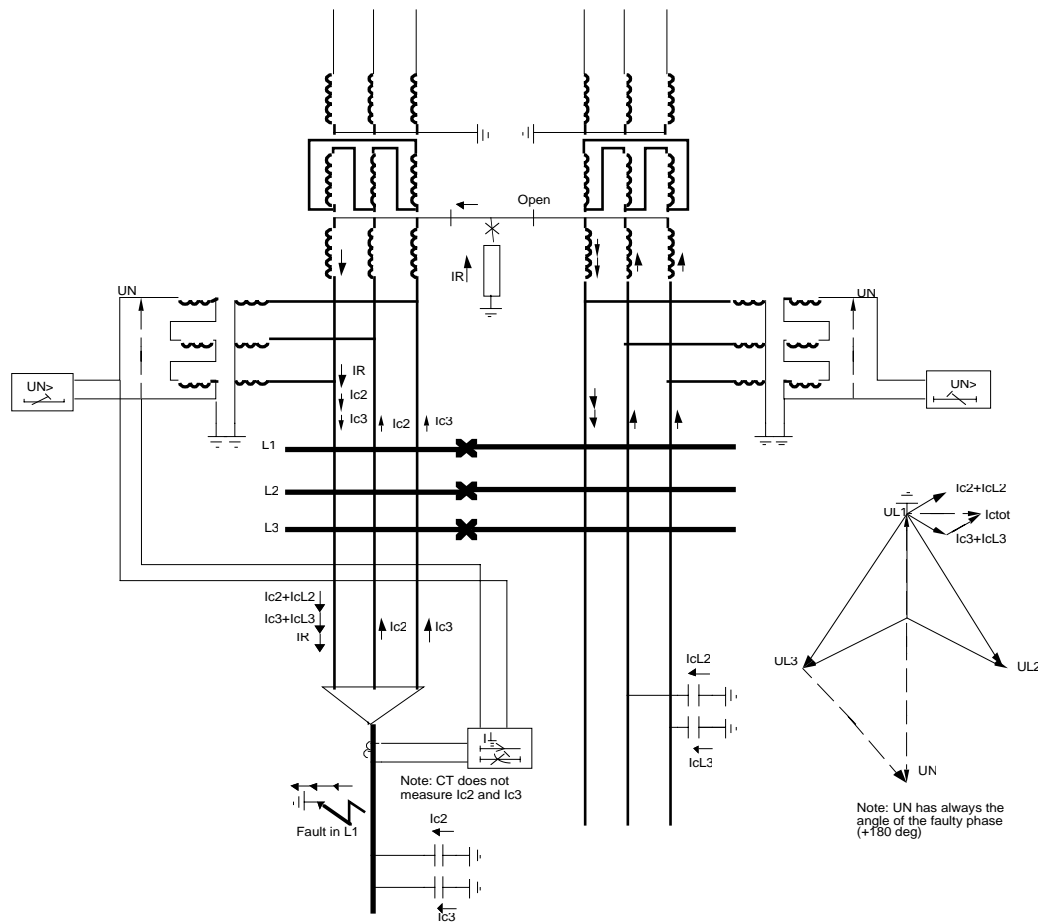

Figure 15. The fault and capacitive current distribution in a high resistance earthed network.

## 4.5 CALCULATION OF EFFICIENCY FACTOR.

The efficiency factor must be calculated when sensitive earth fault relays are used (see later sections).

## 5. RESONANCE EARTHED SYSTEMS

### 5.1 PRINCIPLE

The resonance earthed networks are earthed at the source side of the network only. Normally the earthing is restricted to one point only, or two with parallel transformers, and an arrangement

---

### RESONANCE EARTHED SYSTEMS

is provided to allow connection with the earthing point. This varies with the service conditions. The earthing consists of a tapped reactor tuned to the network capacitance compensating the current and gives a fault current close to zero Amperes at the fault.

In many cases high ohmic resistors is connected in parallel to generate a resistive fault current for the protection system to measure.

Alternatives without this type of resistor and with transient measuring relays as described below are used.

Figure 16 shows the earthing principle and the flow of earth fault current components.

## **5.2 FAULT RESISTANCE AND FAULT CURRENT LEVELS**

The earthing resistor is mostly set to give an earth fault current of 5-15A. The trend to decrease the current level gives lower requirement of earthing grid and higher neutral point voltages at high resistive earth faults.

Due to the low current magnitude, high resistance earth faults will not quickly turn into low resistance. This means that a high fault resistance need to be detected. In Sweden for overhead lines with insulation a fault resistance of 5000  $\Omega$ , must be detected and up to 20 k $\Omega$  alarmed.

For other overhead lines the value for detection is 3000  $\Omega$ .

In order to detect these high values it's often necessary to use a resonance earthing to achieve acceptable high neutral point voltages (>5V at 5000 $\Omega$ ).

Due to the high sensitivity required it's advantageous to use cable current transformers surrounding the three phases to do the measuring. The current transformer is then selected, with a suitable ratio independent of load current, and no current will flow during normal services.

---

### **RESONANCE EARTHED SYSTEMS**



# Earth Fault Protection

A sensitivity down to below 1A primary is required with resonance earthed systems.

## 5.3 NEUTRAL POINT VOLTAGES

In order to detect high values of fault resistance, up to 5000  $\Omega$ , it's often necessary to use a resonance earthing to achieve acceptable high neutral point voltages (>5V at 5000  $\Omega$ ). The neutral point voltage is required to give the directional criteria for the directional earth fault protection and is also used to provide a back-up earth fault protection at the busbar or the transformer bay.

A small neutral point voltage exists, during normal service of the network, due to unsymmetrical capacitance of the phases to earth and current leakage at apparatus as surge arresters. Normally the occurring levels, of unbalance currents, is 0,2 - 5%. Neutral point detection relays and directional relays should therefore never be allowed to have sensitivities below 5-10%. Compare with the requirements of very high sensitivity in solidly earthed systems.

The neutral point voltages are calculated with the fault resistance " $R_f$ ", in series with the neutral reactance " $Z_N$ ". The neutral impedance consists of the earthing resistance " $R_N$ ", the capacitive reactance of the network " $X_C$ " and the reactance of the earthing reactor (normally tuned, " $X_L$ ").

The factor " $R_f/(R_f + Z_N)$ " gives the occurring, per unit, voltage.

The " $Z_N$ " impedance can be calculated " $U_N/(\sqrt{3}I_f)$ ", where  $I_f$  is the total fault current.

It must be remembered that " $Z_N$ ", as well as the vectorial sum have to be calculated. This means that the capacitive and reactive components " $X_C$ " and " $X_L$ " are in opposition and normally will end up close to zero. This means that the fault current is lower and the total reactance also will be close to zero.

---

## RESONANCE EARTHED SYSTEMS

## 5.4 DIRECTIONAL EARTH FAULT PROTECTION

Due to the infeed of capacitive currents, from healthy objects, during an earth fault, it's usually required to use directional earth fault relays. Directional relays are used when the infeed of capacitive current from an object, during a fault in an other object, is higher than 60% of the required sensitivity.

The directional relays will measure the active component of the fault current only, i.e. the current generated by the earthing resistance (the principle for fault current and capacitive current generation is shown in Figure 16).

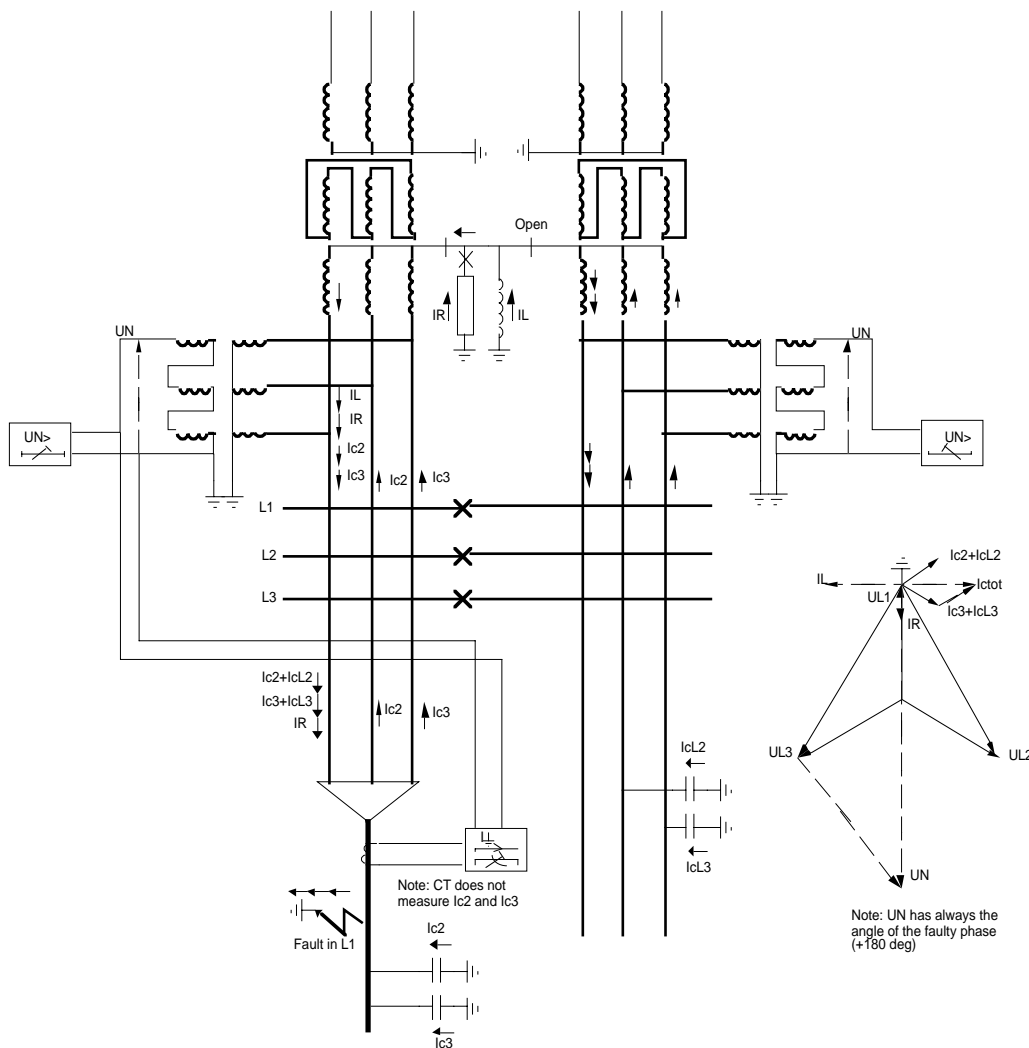

Figure 16. A Directional earth fault relay on a resonance earthed system.

### RESONANCE EARTHED SYSTEMS

# Earth Fault Protection

## 5.5 NEUTRAL POINT CONTROL WITH SPECIAL EQUIPMENT

A new principle for earthing has been discussed in Sweden and some other countries during the last couple of years. This principle includes a neutral point control, where the unsymmetrical voltage occurring in the neutral during normal service is measured, and compensated for in all phases by reactive elements.

The earthing is done with a neutral reactor in combination with a movable core (other solutions exist) able to continuously regulate the reactance and compensate for the capacitive current in the network.

The unsymmetry occurring due to e.g. unsymmetrical capacitances at the different phases to earth as shown in figure 14 will cause a neutral point voltage. This can be compensated for in different ways but phase-wise reactor/resistors as shown in figure 15, will with an intelligent measuring, enable a regulation and a compensation for the unbalance. This means that the neutral point voltage during normal service is zero.

Earth fault currents down to tenth of an ampere can then be achieved and it is possible to have the network in service during an earth fault until it is convenient to take the line out of service for reparation. Earth fault protection must here be arranged, based on other principles than measuring of fundamental earth fault currents. A transient measuring relay as described below is one possible solution.

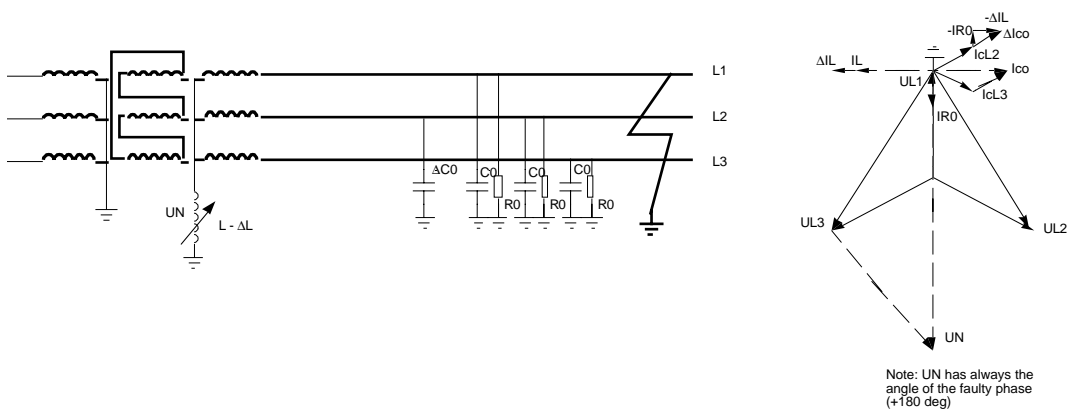

### RESONANCE EARTHED SYSTEMS

Figure 17. Unsymmetrical capacitances giving neutral point voltages during normal service.

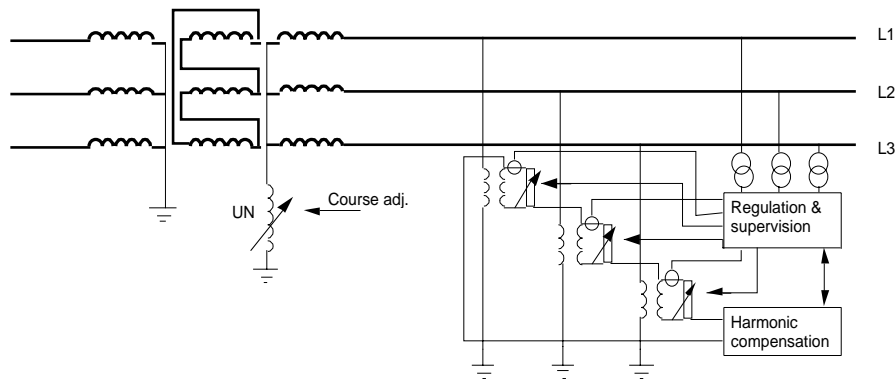

Figure 18. A compensation equipment for neutral point unsymmetry.

## 5.6 TRANSIENT MEASURING RELAYS

In the high resistive, resonance and unearthed systems, an earth fault measuring based on the transient occurring at an earth fault can be used. The transient is caused by the sudden change of voltages and the sudden inrush of capacitive currents into the healthy phases of the power lines.

This current can be measured with a residual sum measurement or with cable current transformers.

The transients occur with a frequency of 100-5000 Hz and is damped out very quickly. Normally within the first half cycle after the fault, see figure 19. The measurement is therefore combined with a measurement of neutral point voltage and the relay will seal-in the direction of the transient as long as the neutral point voltage is available.

Forward as well as reversed direction can be detected by the direction of the transient.

Transient measuring relays can for resonance earthed system be set to be sensitive to high resistive earth faults if no resistor is used, as the occurring neutral point voltages will be rather high.

---

### RESONANCE EARTHED SYSTEMS

# Earth Fault Protection

The transient in the current is independent of the neutral device as this is caused by the transient change of voltages.

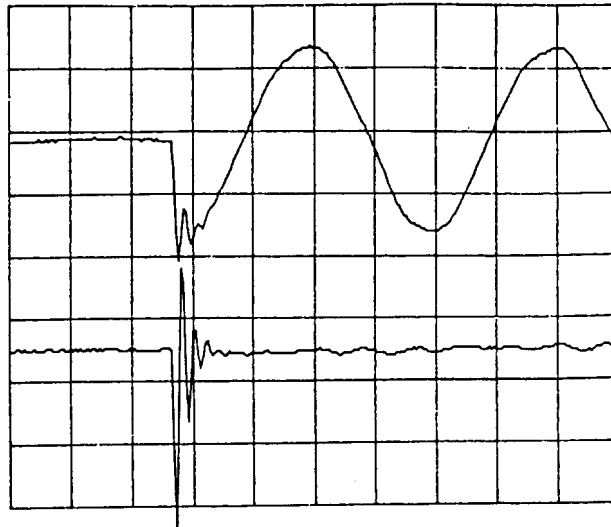

Figure 19. The neutral point voltages and the high frequency transient occurring at an earth fault.

## 6. MEASURING EARTH FAULT CURRENT

### 6.1 INTRODUCTION

At earth faults in a three phase system the residual sum of the three phase currents will not end up to zero as during normal service. The earth fault current can be measured by a summation of the three phase currents.

The summation can either be made by a summation of the three phase current transformers, in a residual sum connection or by a

cable current transformer surrounding the three phase conductors. Figure 20 shows the alternatives).

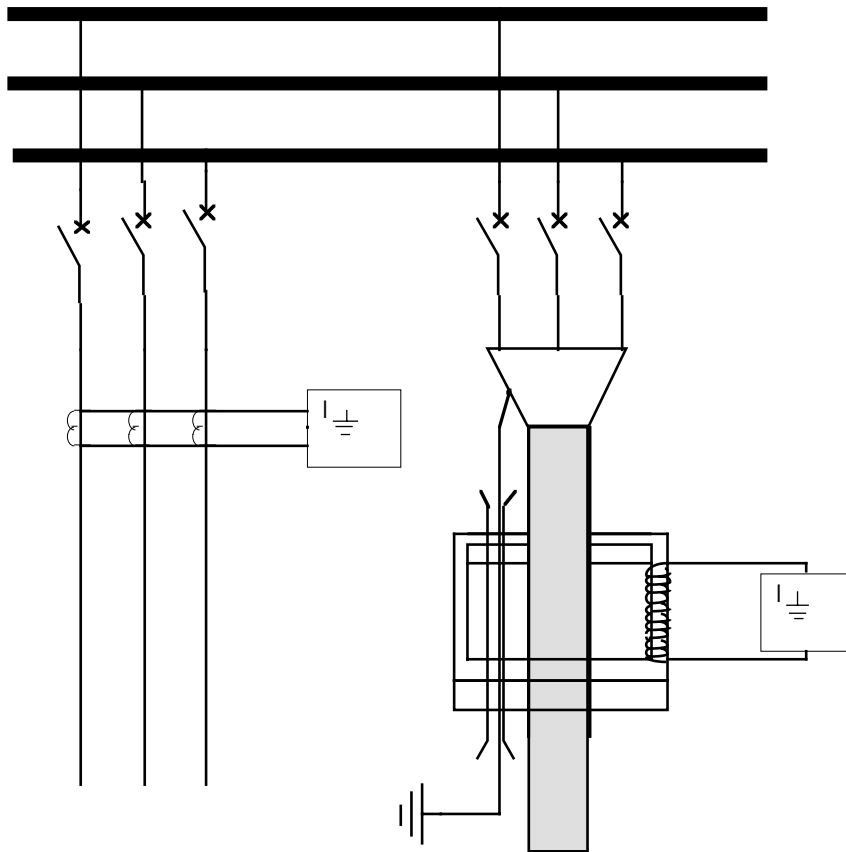

Figure 20. Measurement of earth fault current can be made with a residual sum measurement of a cable CT surrounding all three phases.

---

## MEASURING EARTH FAULT CURRENT

# Earth Fault Protection

## 6.2 RESIDUAL SUM CONNECTED CURRENT TRANSFORMERS

When a residual sum connection is used a residual current can be achieved caused by the small differences between the current transformers in the three phases. Especially during a short circuit, the residual current can reach high values. This can make high sensitivity earth fault relays operate e.g. in high resistive or resonance earthed systems.

To prevent operation of earth fault relays a release of earth fault relay by a neutral point voltage protection and/or a blocking of the earth fault relay at operation of an overcurrent protection should be performed

A much higher sensitivity can be achieved with cable current transformers than with residual connected phase current transformers, as the current ratio can be selected freely. In the residual connected case the current transformers are given a ratio above the maximum load currents.

For reactance- and solidly earthed systems this is not necessary due to the low sensitivity of the earth fault protection.

## 6.3 CABLE CURRENT TRANSFORMER

Cable current transformers are available in varying types with different mounting principles, different ratios and for different cable diameters. Epoxy quartz transformers must be threaded onto the cable end before the cable box is mounted. Transformers with openable cores can be mounted after mounting of the cables is done.

Different ratios are used. Today 150/5 and 100/1A is common whereas 200/1A has been a common figure in the past.

A much higher sensitivity can be achieved with cable current transformers than with residual connected phase current trans-

---

### MEASURING EARTH FAULT CURRENT

formers as the current ratio can be selected freely. When residual connected the current transformers are given a ratio higher than the maximum load currents.

For reactance- and solidly earthed systems this is not necessary due to the low sensitivity of the earth fault protection.

The earth fault protection relays setting range must be selected together with the current transformer ratio to give the requested primary sensitivity.

## **6.4 MOUNTING OF CABLE CURRENT TRANSFORMER**

In order to achieve a correct measurement the cable sealing end must be insulated from earth and the cable screen earthing must be done as in Figure 20. The current in the cable screen will then be in opposite direction to the current in the earthing connection, and will thus not be measured. Therefore the fault current going out to the fault is the only current to be measured.

The cable must be centralized in the hole of the transformer in order to prevent unbalance currents.

Cables are normally earthed at one end only if they are single-phased. This is to prevent the load current causing an induced current flowing in the screen/armour. If the cables are three phase one- or two ends can be earthed.

## **7. CALCULATION OF EFFICIENCY FACTOR**

### **7.1 EARTH FAULT RELAY SENSITIVITY**

When the primary earth fault current " $3I_0$ " is transformed in the residual sum connected current transformers or in the cable current transformer a part of the current is used to magnetize the current transformers to the terminal voltage " $U$ " required to achieve the operating current in the relay.

---

#### **CALCULATION OF EFFICIENCY FACTOR**



# Earth Fault Protection

The phase angle must be considered at calculation of the efficiency factor “ $\eta$ ”:

$$\eta = I_{\text{set}} / 3I_0 \times n$$

where “ $I_{\text{set}}$ ” is the set value of the earth fault relay, “ $3I_0$ ” is the primary earth fault current and “ $n$ ” is the turns ratio of the current transformer

---

## CALCULATION OF EFFICIENCY FACTOR

# Current Transformers

## 1. INTRODUCTION

The main tasks of instrument transformers are:

- To transform currents, or voltages, from a high value to a value easy to handle for relays and instruments.
- To insulate the metering circuit from the primary high voltage.
- To provide possibilities of a standardization, concerning instruments and relays, of rated currents and voltages.

Instrument transformers are special types of transformers intended for measuring of voltages and currents.

For the instrument transformers, the common laws for transformers are valid.

For a short circuited transformer:

$$\frac{I_1}{I_2} = \frac{N_2}{N_1}$$

For a transformer at no load:

$$\frac{E_1}{E_2} = \frac{N_1}{N_2}$$

First equation gives the current transformation in proportion to the primary and secondary turns.

Second equation gives the voltage transformation in proportion to the primary and secondary turns.

The current transformer is based on equation 1 and is ideally a short-circuited transformer where the secondary terminal voltage is zero and the magnetizing current is negligible.

The voltage transformer is based on equation 2 and is ideally a transformer under no-load condition, where the load current is zero and the voltage drop only is caused by the magnetizing current and therefore is negligible.

---

## INTRODUCTION

In practice, the ideal conditions are not fulfilled as the instrument transformers have a burden in form of relays, instruments and cables. This causes a measuring error in the current transformer due to the magnetizing current, and in the voltage transformer due to the load current voltage drop.

The vector diagram for a single phase instrument transformer is shown in figure 1. The turn ratio is scaled 1:1 to simplify the representation. The primary terminal voltage is " $U_1$ " multiplied with the vectorial subtraction of the voltage drop " $I_1 Z_1$ " from " $U_1$ ", which gives us the emf " $E$ ". " $E$ " is also the vectorial sum of the secondary terminal voltage " $U_2$ " and the secondary voltage drop " $I_2 Z_2$ ". The secondary terminal voltage " $U_2$ " is expressed as " $I_2 Z$ ", where " $Z$ " is the impedance of the burden.

The emf " $E$ " is caused by the flux  $\Phi$ , lagging " $E$ " with  $90^\circ$ . The flux is created by the magnetizing current " $I_m$ ", in phase with  $\Phi$ . " $I_m$ " is the no load currents " $I_0$ 's" reactive component in phase with " $E$ ". The resistive component is the power loss component " $I_f$ ".

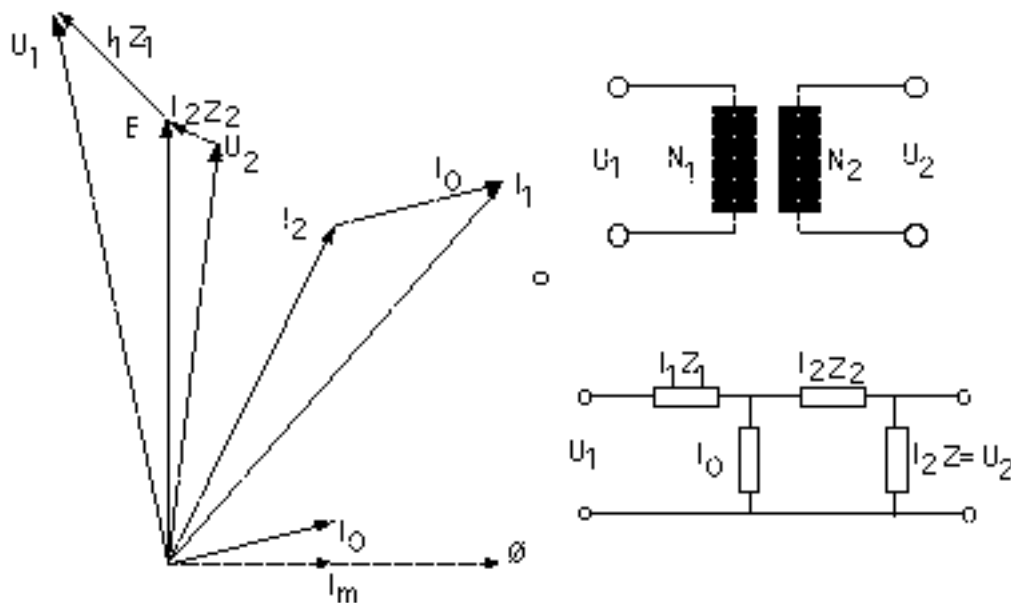

Figure 1. The principle of an instrument transformer.

## INTRODUCTION

# Current Transformers

## 2. MEASURING ERROR

The current transformer is normally loaded by an impedance, consisting of relays, instruments and, perhaps most important, the cables.

The induced emf “E”, required to achieve the secondary current “I<sub>2</sub>”, through the total burden “Z<sub>2</sub>+Z”, requires a magnetizing current “I<sub>0</sub>”, which is taken from the primary side current. The factor “I<sub>0</sub>”, is not part of the current transformation and used instead of the rated ratio “K<sub>n</sub>”.

$$\text{Nominal ratio } K_n = \frac{I_1}{I_2}$$

we will get the real current ratio “K<sub>d</sub>”,

$$\text{Real ratio } K_d = \frac{I_1 - I_0}{I_2}$$

where “I<sub>1</sub>”, is the primary rated current and “I<sub>2</sub>”, is the secondary rated current.

The measuring error “ε” is defined:

$$\varepsilon = \frac{K_n I_s - I_p}{I_p} \times 100$$

where “I<sub>s</sub>”, is the secondary current and “I<sub>p</sub>”, is the primary current.

The error in the reproduction will appear, both in amplitude and phase.

The error in amplitude is called current, or ratio, error. According to the definition, the current error is positive, if the secondary current is higher than the rated current ratio.

---

### MEASURING ERROR

The error in phase angle, is called phase error or phase displacement. The phase error is positive, if the secondary current is leading the primary.

If the magnetizing current “ $I_0$ ” is in phase with the secondary current “ $I_2$ ” (the maximum error), we will, according to equation 6, get the error  $\varepsilon$ .

$$\varepsilon = \frac{K_d - K_n}{K_d} \times 100 = \frac{\frac{I_1 - I_0}{I_2} - \frac{I_1}{I_2}}{\frac{I_1}{I_2}} \times 100 = \frac{I_0}{I_1} \times 100$$

“ $I_0$ ” is consisting of two components, a power-loss component “ $I_f$ ”, in phase with the secondary voltage and a magnetizing component “ $I_m$ ”, lagging  $90^\circ$  and in phase with the emf “ $E$ ”.

The magnetizing current causing the measuring error, depends on several different factors (as shown in Figure 2).

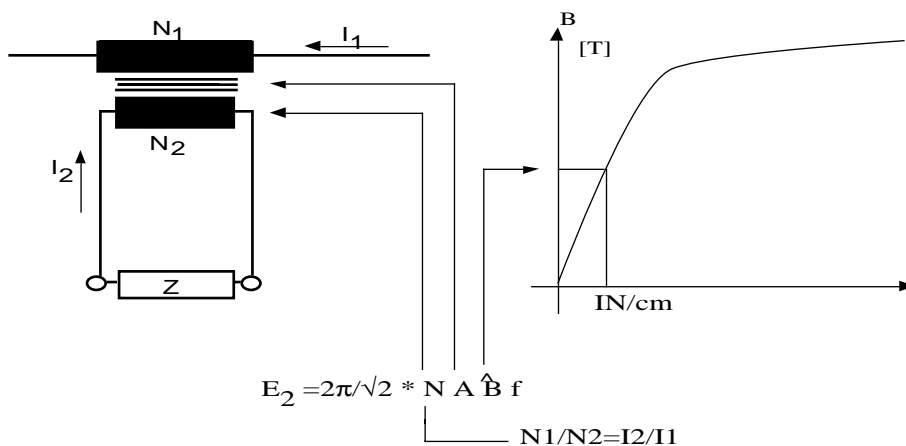

Figure 2. The factors influencing the current transformers output and magnetizing current.

For the induced emf “ $E$ ”, the normal formula is valid, see fig 2. The induced emf is given the capability to carry burdens the same size as a transformer.

The burden is defined in IEC 185 as the power in VA can be connected to a current transformer at secondary rated current and at a given power factor ( $\cos \varnothing = 0,8$  according to IEC 185). The secondary rated current is standardized to 1 and 5 A. The output volt-

## MEASURING ERROR

# Current Transformers

age of a current transformer, shows the capability of the transformer to carry burden.

As shown in figure 2, three factors will influence the emf “E”. It’s the number of secondary turns “N”, the core area “A” and the induction in  $\text{Wb/m}^2$  “B”. The induction is dependent of the core material, which influences the size of the magnetizing current. For a certain application the secondary turns and the core area are thus selected to give the required emf output.

## 3. CURRENT TRANSFORMER OUTPUT

The output required of a current transformer core is dependent of the application and the type of load connected.

**METERING OR INSTRUMENTS** Equipment like kW-, kVAr- and A instruments or kWh and kVAh meters measures under normal load conditions. For metering cores a high accuracy for currents up to the rated current (5-120%), is required. Accuracy classes for metering cores are 0.1 (laboratory), 0.2, 0.5 and 1.

**PROTECTION AND DISTURBANCE RECORDING** In Protection relays and Disturbance recorders the information about a primary disturbance must be transferred to the secondary side. For these cores a lower accuracy is required but also a high capability to transform high fault currents and to allow protection relays to measure and disconnect the fault. Protection classes are 5P and 10P according to IEC 185. Further cores for transient behavior are defined in IEC 44-6.

In each current transformer a number of cores can be contained. From three to six cores are normally available and the cores are then one or two for measuring purposes, and two to four for protection purposes.

---

### CURRENT TRANSFORMER OUTPUT

### 3.1 METERING CORES

To protect instrument and meters from high fault currents the metering cores must be saturated 10-40 times the rated current depending of the type of burden. Normally the energy meters have the lowest withstand capability. Typical values are 12-20 times the rated current. The instrument security factor “ $F_s$ ”, indicates the overcurrent as a multiple of rated current at which the metering core will saturate. This is given as a maximum value and is valid only at rated burden. At lower burdens the saturation value increases approximately to “ $n$ ”.

$$n = \frac{R_{CT} + \left(\frac{S}{I_n}\right)^2}{R_{CT} + \left(\frac{S_n}{I_n}\right)^2} \times F_s$$

where “ $S_n$ ” is the rated burden in VA, “ $S$ ” is the actual burden in VA, “ $I_n$ ” is the rated secondary current in A and “ $R_{ct}$ ” is the internal resistance in  $\Omega$ , at 75 °C.

According to IEC 185 the accuracy class shall be fulfilled from 25 to 100% of the rated burden.

To fulfil the accuracy class and to secure saturation for a lower current than instrument/meter thermal capability the rated burden of the core must be relatively well matched to the burden connected.

#### Standards.

Table 1 below shows the requirement in IEC 185 for ratio and angle error for different classes for a protection respectively a metering core.

class	meas. error e (%) at $I_n$ resp ALF	angle error (min) at $I_n$	purpose
0.2	0,2	10	rev. metering
0.5	0,5	30	stat. metering
1	1	60	instrument
5P	1,0 at $I_n$ , 5 at $ALF \cdot I_n$	60	protection
10P	3 at $I_n$ , 10 at $ALF \cdot I_n$	180	protection

---

## CURRENT TRANSFORMER OUTPUT



# Current Transformers

*Table 1. The accuracy classes for a current transformer. For metering classes there are additional requirements for 5 and 20% of  $I_n$ .*

## 3.2 PROTECTION CORES

The main characteristics of protection CT cores are:

- Lower accuracy than for measuring transformers.
- High saturation voltage.
- Little, or no turn correction at all.

The factors defined the cores are:

- The composite error with class 5P and 10 P. The error is then 5 respectively 10%, at the specified ALF and at rated burden.
- The Accuracy Limit Factor “ALF” indicates the overcurrent as a multiple, times the rated current, up to which the rated accuracy (5P or 10P) is fulfilled (with the rated burden connected).
- The ALF is given as a minimum value and in the same way as for  $F_S$  for a metering Core, the overcurrent factor is changed when the burden is different to the rated burden.

The formula for the overcurrent factor “n” achieved for a connected burden different than the rated burden is similar to the formula for metering cores.

$$n = \frac{R_{CT} + \left(\frac{S}{I_n}\right)^2}{R_{CT} + \left(\frac{S_n}{I_n}\right)^2} \times ALF$$

where “ $S_n$ ” is the rated burden in VA, “ $S$ ” is the actual burden in VA, “ $I_n$ ” is the rated secondary current in A and “ $R_{ct}$ ” is the internal resistance in  $\Omega$ , at 75 °C.

Note that the burdens today are generally pure resistive and much lower than the burdens, several years ago, when electromagnetic relays and instruments were used.

---

## CURRENT TRANSFORMER OUTPUT

### 3.3 TRANSIENT BEHAVIOR

The short-circuit current can be expressed as:

$$i_k = I_k [\cos \phi \times e^{-t/T_1} - \cos(\omega t + \phi)]$$

where “ $i_k$ ” is the instantaneous value of the fault current, “ $I_k$ ” is the instantaneous amplitude value of the fault current and “ $\phi$ ” is the phase angle, at the fault inception.

The variable “ $\phi_1$ ” is set to zero, i.e. a pure resistive burden which is the normal situation and simplifies the calculation. The first part of the formula is the DC component of the fault current and the second part is the pure AC component.

The “ $e^{t/T_1}$ ”, implies that the DC component is a decaying exponential function, with the time constant “ $T_1$ ”. The maximum amplitude depends on where on the voltage sine wave the fault occurred.

Concerning the protection relays, intended to operate during the fault, it's important to check the core output under transient conditions.

The fault must occur between two extreme conditions:

1.  $\phi=90^\circ$  i.e. a fault at voltage maximum. The fault current will be a pure sinus wave. To transform the fault current without saturation, the ALF factor must be  $ALF \geq I_k/I_n$ .
2.  $\phi=0^\circ$  i.e. a fault at voltage zero. The short circuit current will have full a symmetry with a maximum DC component. Fortunately these cases are quite rare as faults normally occur close to voltage maximum rather than close to voltage zero.

The DC component will build up a DC flux in the core and an interposed AC flux. The flux will increase and decrease according to the time constants. The rise is dependent of the network time

# Current Transformers

constant " $T_1$ " ( $L/R$ ) and the decay follows the current transformers secondary time constant " $T_2$ ".

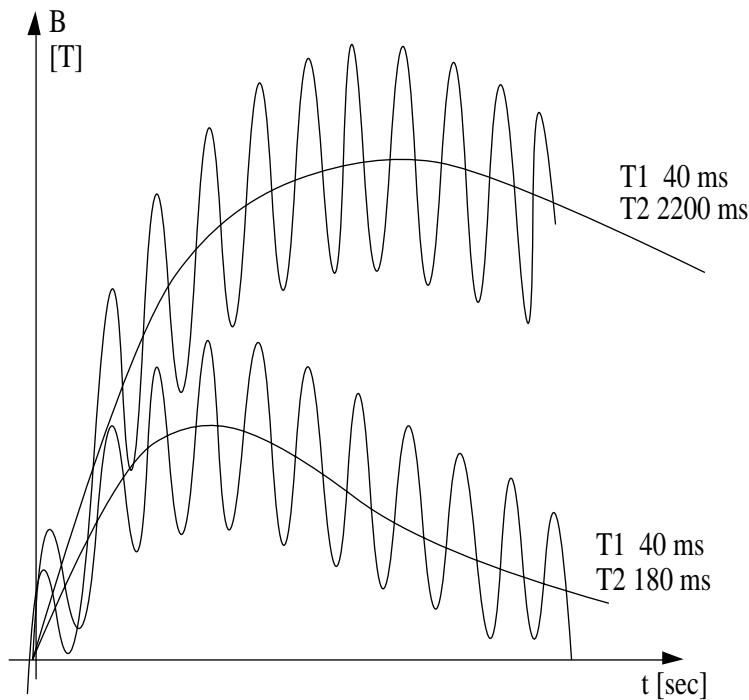

Figure 3. AC and DC flux dependent of time, at faults with full DC component and with different primary and secondary time constants.

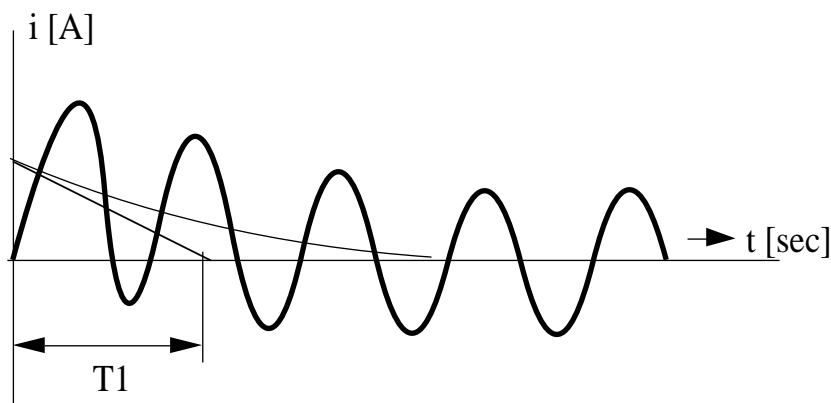

Figure 4. The primary fault current with a DC component.

" $T_2$ " is the current transformer secondary time constant " $L_0/R_0$ ", where " $L_0$ " is the inductance of the secondary winding and " $R_0$ " is the resistance of the secondary winding.

---

## CURRENT TRANSFORMER OUTPUT

The quotient between the maximum value of the DC component and the maximum value of the AC component is called the transient factor “ $K_T$ ” and is defined:

$$K_T = \frac{\hat{\phi}(\text{ac flux}) \times (\omega T_1 \cos \phi^2 - \sin \phi^2)}{\hat{\phi}(\text{ac flux})}$$

which for a resistive burden ( $\cos \phi^2 = 1,0$ ). This gives “ $K_T = \omega T_1$ ”, which with a primary time constant of, e.g. “ $T_1 = \frac{L}{R} = 100 \text{ ms} = 31.4$ ”, which in turn gives a DC flux “31.4” multiplied with the AC flux.

To transform the short circuit current correctly, the protection core must have an ALF factor “31.4” multiplied with the ALF factor for case 1.

The situation becomes even worse if a quick auto-reclosing is used. At fault current breaking the core will be left magnetized to “ $\phi_{\text{max}}$ ” as the breaking is made at current zero crossing i.e. voltage is close to maximum and the flux is thus also close to maximum. The remanence flux “ $\phi_r$ ” in the core will decay according to the formula:

$$\phi_r t = \phi_{\text{max}} \times e^{-\frac{t}{T_2}}$$

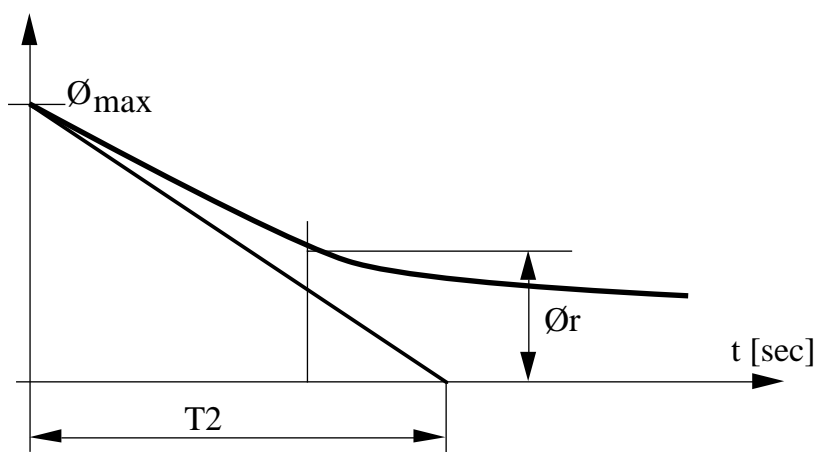

Figure 5. The decay of the flux and the remanence flux.

At a reclosing for a permanent fault after the time “ $t$ ” (the same flux direction is foreseen in the worst case), a part of the core is

---

## CURRENT TRANSFORMER OUTPUT

# Current Transformers

already used for the remanence flux. To manage a correct transformation of the current during an auto reclosing sequence the core must be further increased with a remanence factor “ $K_r$ ”.

This factor is according to IEC:

$$K_r = \frac{f_{\max}}{f_{\max} - f_r}$$

The current transformer cores must thus be increased with the transient- and the remanence factor “ $K_T$ ” and “ $K_r$ ”. This is required, if saturation isn’t allowed during the transient fault having a full DC offset and with an Auto reclose sequence.

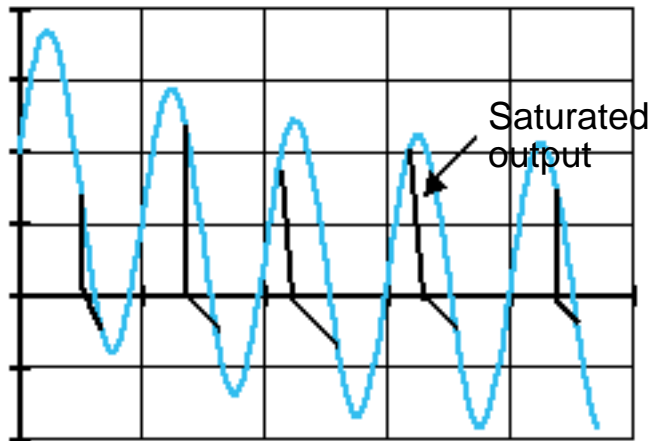

Figure 6. Secondary current at DC saturation. For some cycles the positive part of the sine wave will be destroyed.

Ideal transformation of short circuits using DC component and during Auto reclose will give very high over dimensioning requirements. All clearances of parameters will be multiplied and can give unrealistic requirements on core size after multiplying with “ $K_T$ ” and “ $K_r$ ”.

---

## CURRENT TRANSFORMER OUTPUT

## 4. SELECTION OF CT CORES

Some general guidelines for selecting current transformer cores, for metering and protection purposes, can be given.

**SELECT THE RATED CURRENT** The primary rated current is selected to be 10-40% higher than the object rated current. This always gives a high resolution of the metering equipment and instruments.

For the protection cores it can be of interest to have the highest possible ratio as this gives the least requirements of core data. The modern relays have wide measuring ranges.

A primary- or secondary tap to get several ratios can be useful in metering cores. Remember however that the output is reduced when fewer turns are used.

The secondary current can be 1 or 5 A. Today 1A is the dominating as the protection and metering equipment have so low burdens. The cable burden is " $I^2R$ " which indicates that a 1A circuit has 25 times lower cable burden, measured in VA, than a 5 A circuit. This means that cores can be made in smaller dimensions with a lower cost as a result.

**SELECT BURDEN** Do not use an over dimensioned burden more than necessary. A too high rated burden compared to actual burden can mean that the metering equipment is destroyed as the Security factor " $F_s$ " factor is valid at rated burden.

For relay cores an extra clearance concerning burden can give unrealistic core sizes after multiplication with " $K_T$ " and " $K_r$ ".

**SELECT " $F_s$ " AND ALF FACTORS** Select the correct Security factor  $F_s$  and Accuracy Limit Factors ALF, dependent of the type of equipment connected. Always refer to the product description and check the overcurrent capability for instruments and meters and the requirement on core output for relays.

---

### SELECTION OF CT CORES

# Current Transformers

Remember also possible clearances of the burden which will influence the real Overcurrent factor.

## ***Do not overdimension!***

In practice all current transformer cores should be specially adapted for their application in each station.

**SELECT ACCURACY** Do not specify higher requirements than necessary. For metering cores especially with A-turns less than about 400-500 a too high requirement can mean extra expenses as a more expensive core material must be used.

## ***SOME RULES OF THUMB***

The secondary resistance " $R_{CT}$ " is important for the CT output and should be limited, specially for 1 A high ratio CT's, to give an efficient use of the current transformers i. e. the core voltage output shall be used to support the connected burden and not the internal resistance. A good goal could be to always have internal resistance lower than rated burden, preferable much lower.

When the secondary resistance following rule of thumb can be used:

$$R_{CT} \leq 0,2 - 0,5 \Omega \text{ per } 100 \text{ turns.}$$

Bigger values for big cores and small values for small cores.

Cores are considered to be big when the voltage output is of range 1 - 2 V per 100 turns and medium size cores have outputs 0,5 - 1 V per 100 turns.

Generally the resistance values are lower for 5 A circuits as the winding has bigger Area for 5 A than for 1 A. However the problem that the secondary resistance is high is occurring mainly on 1 A as the number of turns are five times higher for 1 A than for 5 A. It is thus essential to keep core size and secondary resistance down to get useful cores where the voltage output is mainly producing current to the load and not giving internal voltage drop and power loss.

---

## SELECTION OF CT CORES

---

## SELECTION OF CT CORES



# Voltage Transformers

## 1. VOLTAGE TRANSFORMER (VT) AND CAPACITIVE VOLTAGE TRANSFORMER (CVT)

### 1.1 INTRODUCTION

Voltage transformers can be of two types, magnetic voltage transformers (VT) and capacitive voltage transformers (CVT). The magnetic voltage transformers are most economical for voltages up to about 145 kV and the capacitive voltage transformers there above. A CVT can also be combined with the PLC equipment used for communication over the high voltage transmission lines.

Voltage transformers are in most cases connected between phase and earth.

Voltage transformers are together with current transformers called instrument transformers. The standard covering voltage transformers is IEC 186.

The main tasks of instrument transformers are:

- To transform currents or voltages from a usually high value to a value easy to handle for relays and instruments.
- To insulate the metering circuit from the primary high voltage.
- To provide possibilities of a standardization of instruments and relays to a few rated currents and voltages.

Instrument transformers are special types of transformers intended for measuring of voltages and currents.

For the instrument transformers the common laws for transformers are valid.

For a short circuited transformer the following formula is valid:

$$\frac{I_1}{I_2} = \frac{N_2}{N_1}$$

For a transformer in no load the following formula is valid:

$$\frac{E_1}{E_2} = \frac{N_1}{N_2}$$

---

### INTRODUCTION

Equation (1) gives the current transformation in proportion to the primary and secondary turns. Equation (2) gives the voltage transformation in proportion to the primary and secondary turns. The current transformer is based on equation (1) and ideally a short-circuited transformer where the secondary terminal voltage is zero and the magnetizing current is negligible.

The voltage transformer is based on equation (2) and is ideally a transformer under no-load condition where the load current is zero and the voltage drop is only caused by the magnetizing current and is thus negligible.

In practice the ideal conditions are not fulfilled as the instrument transformers are loaded with burden in form of relays, instruments and cables. This causes a measuring error in the current transformer due to the magnetizing current and in the voltage transformer due to the load current voltage drop.

The vector diagram for a single phase instrument transformer is shown in figure 1.

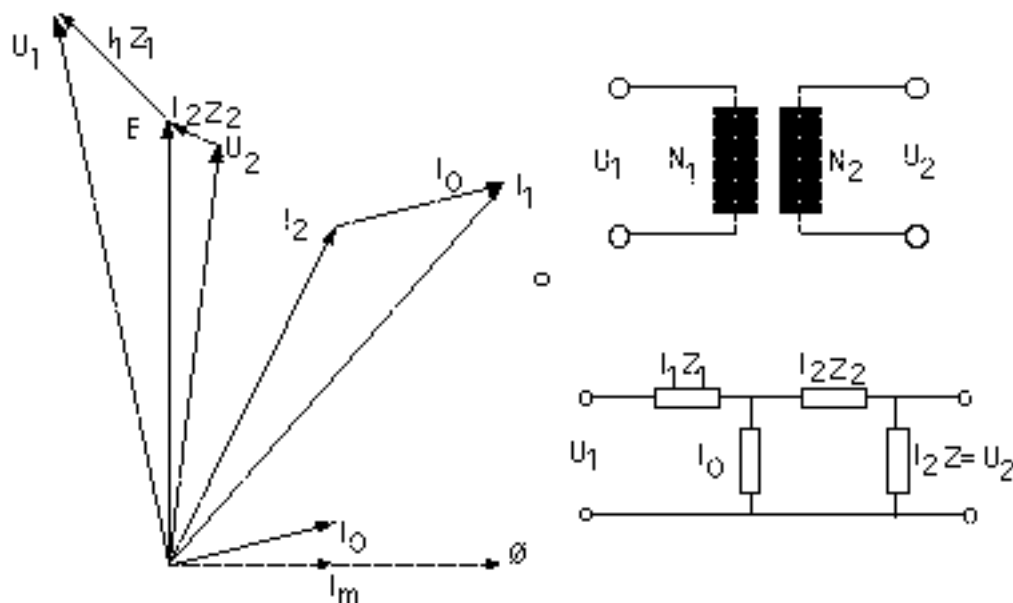

Figure 1. The principle of an Instrument transformer.

The turn ratio is 1:1 to simplify the representation. The primary terminal voltage is  $U_1$ . The vectorial subtraction of the voltage drop  $I_1Z_1$  from  $U_1$  gives us the emf  $E$ .  $E$  is also the vectorial sum of the secondary terminal voltage  $U_1$  and the secondary voltage drop  $I_2Z_2$ . The secondary terminal voltage  $U_2$  is expressed as  $I_2Z$  where  $Z$  is the impedance of the burden.

---

## INTRODUCTION

# Voltage Transformers

The emf  $E$  is caused by the flux  $\Phi$  lagging  $E$  with  $90^\circ$ . The flux is created by the magnetizing current  $I_m$  in phase with  $\Phi$ .  $I_m$  is the no-load current  $I_0$  reactive component and in phase with  $E$  is the resistive component the power loss component  $I_f$ .

## 1.2 MEASURING ERROR

The voltage transformer is normally loaded by an impedance consisting of relays, instruments and, perhaps most important, the cables.

The induced emf  $E$  required to achieve the secondary current  $I_2$  through the total burden  $Z_2+Z$ , requires a magnetizing current  $I_0$  which is taken from the primary side voltage.

The  $I_0$  is not part of the voltage transformation and instead of the rated ratio  $K_n$ :

$$\frac{U_1}{U_2} = \text{Nominal ratio } K_n$$

we will get the real voltage ratio  $K_d$ :

$$\frac{U_1 - \Delta U}{U_2} = \text{Real ratio } K_d$$

where

$U_1$  is the primary rated voltage

$U_2$  is the secondary rated voltage

The measuring error  $\varepsilon$  is defined (IEC 186) as:

$$\frac{U_1}{U_2} - \frac{U_1 - \Delta U}{U_2} \times \frac{U_2}{U_1} = \frac{\Delta U}{U_1} \times 100 = \varepsilon(5)$$

where

$U_1$  is the primary voltage

$U_2$  is the secondary voltage

---

## MEASURING ERROR

The error in the reproduction will appear both in amplitude and phase.

The error in amplitude is called voltage or ratio error. According to the definition, the voltage error is positive if the secondary voltage is higher than the rated voltage ratio would give.

The error in phase angle is called phase error or phase displacement. The phase error is positive if the secondary voltage is leading the primary.

According to the figure

$$\Delta U = \Delta E_1 + \Delta E_2$$

$$\Delta E_1 = I_1 Z_1$$

$$\Delta E_2 = I_2 Z_2$$

If  $Z_1 + Z_2 = Z_k$  and  $I_1 = I_0 + I_2$  we will get

$$\Delta U = I_0 Z_1 + I_2 Z_k$$

The error of a voltage transformer is thus dependent of one part independent of the load current, but dependent of the voltage  $U$  and the flux density and magnetizing curve, and one part dependent of the load current.

The magnetizing current which causes the measuring error depends on several different factors as shown in Figure 2.

For the induced emf  $E$  the normal formula is valid, see fig. The induced emf is also gives the size of a transformer capability to carry burden.

The no load voltage drop  $I_0 \cdot Z_1$

Following relations are valid:

$$I_0 = f(B)$$

$$I_0 Z_1 = f(B) \cdot R_1 + j f(B) \cdot X_1$$

To achieve a low voltage drop following steps should be taken:

- The primary winding is wound with a wire with big Area.
- A low induction is used
- The reactance is kept low

This implies that a big core area must be used in order to flux high enough and a not to high number of primary turns as the reactance has a square dependence of the turns number.

The load dependent voltage drop  $I_2 Z_k$ .

$$Z_k = R_1 + jX_1 + R_2 + jX_2$$

---

## MEASURING ERROR

# Voltage Transformers

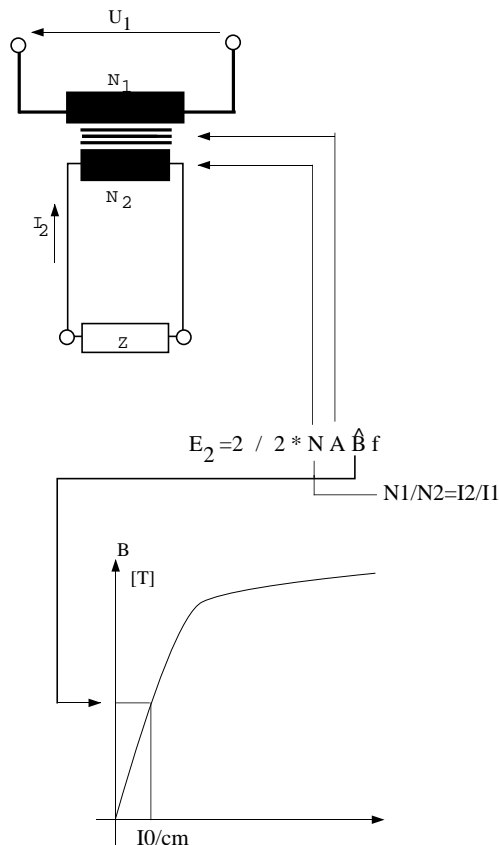

Figure 2. The factors influencing the voltage transformer output and magnetizing current.

To keep a low voltage drop due to the load current the primary and secondary impedances must be kept as low as possible which in practice means that a winding with big area on the wires is used and the coils are made as compact as possible to reduce the leakage flux.

The measuring error variation with the voltage.

The no load error  $I_0 Z_1$  varies with the voltage following the magnetizing curve of the transformer, the primary impedance  $Z_1$  can be considered as a constant.

The load dependent voltage drop is proportional to  $U_2$  as  $I_2 = U_2/Z$  where  $Z$  is the connected burden and  $Z_1$  and  $Z_k$  are constants.

The relative voltage drop is thus constant.

---

## MEASURING ERROR

Turns correction is often used on voltage transformers to achieve a high accuracy. The high number of turns gives a possibility to regulate in small steps.

According to IEC 186 a voltage transformer is required to fulfil its accuracy class for burdens between 25 and 100% of rated burden. A turns correction is mostly selected to give a positive error  $+\epsilon_{\max}$  at a burden of 25% of rated burden and  $-\epsilon_{\max}$  at a burden of 100% of rated burden. This is shown in Figure 3.

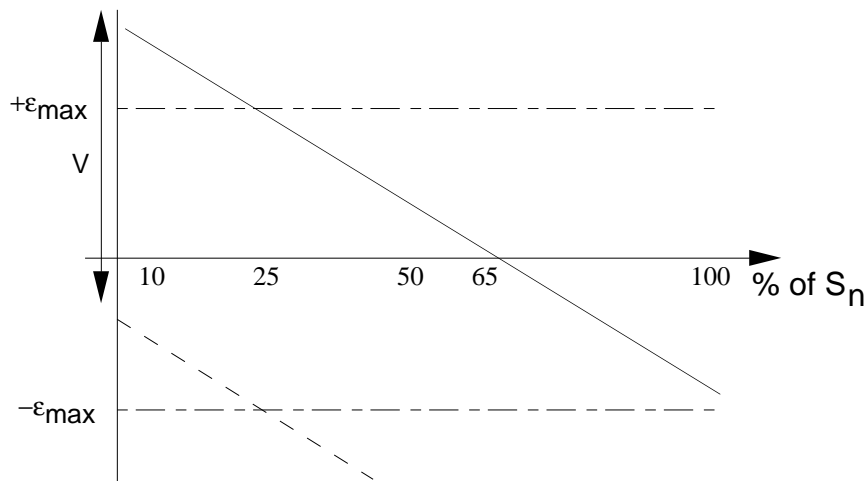

Figure 3. The measuring error as a factor of secondary burden at a constant primary voltage.

### 1.3 VOLTAGE TRANSFORMERS WITH SEVERAL SECONDARY WINDINGS.

The voltage transformers can be designed with more than one secondary windings. This is done when secondary windings for different purpose are needed. Each loaded secondary winding will take load current from the primary winding and the total voltage drop is caused by the sum of the secondary burdens.

The most common design is to provide one Y-connected winding and one extra secondary winding for open delta connection, used for earth fault protection relays. This winding is not loaded during normal service and will thus not influence the measuring accuracy. The open delta winding is normally provided with 110 V secondary for solidly earthed systems and for 110/3 V for unearthed, reactance or resistance earthed systems. This will give an open delta output of 110 V during a solid earth fault in both systems.

---

#### VOLTAGE TRANSFORMERS WITH SEVERAL SECOND-

# Voltage Transformers

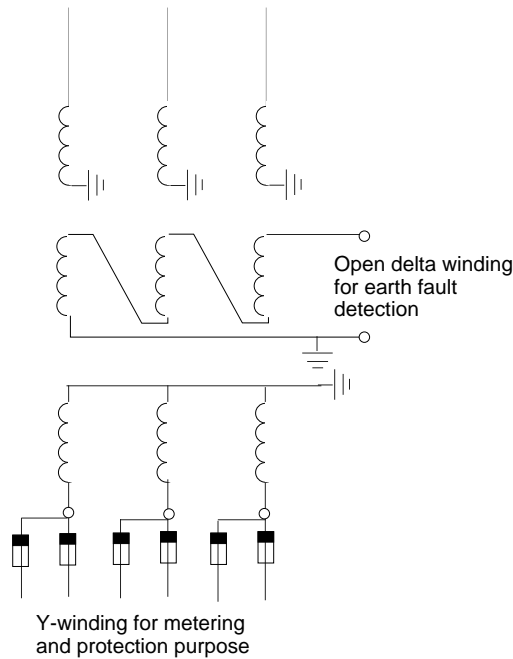

Figure 4. A Voltage transformer with two secondary windings, one Y-connected and one Open delta connected.

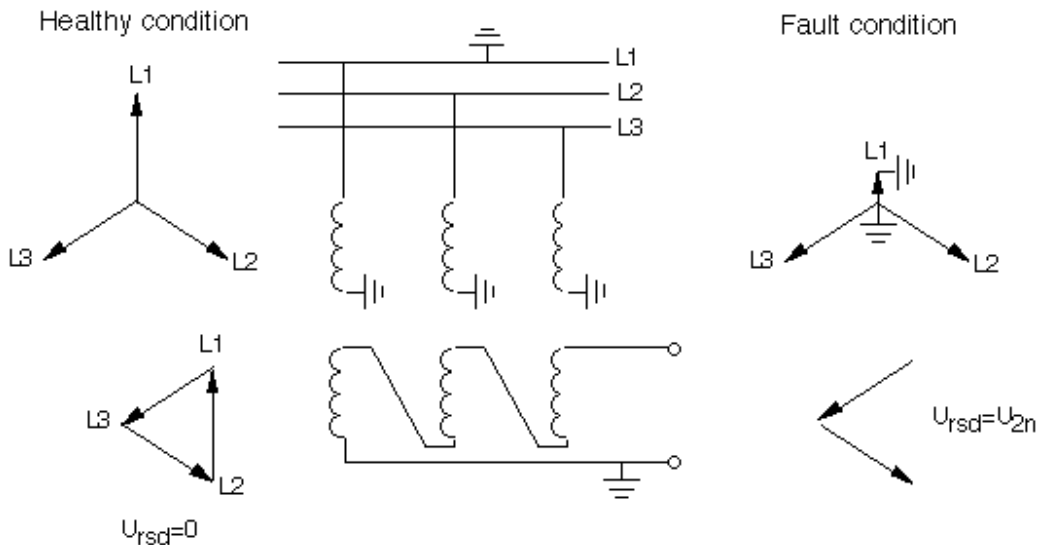

Figure 5. The principle for a open delta winding. Occurring voltages at an earth fault in a direct earthed system.

## VOLTAGE TRANSFORMERS WITH SEVERAL SECOND-

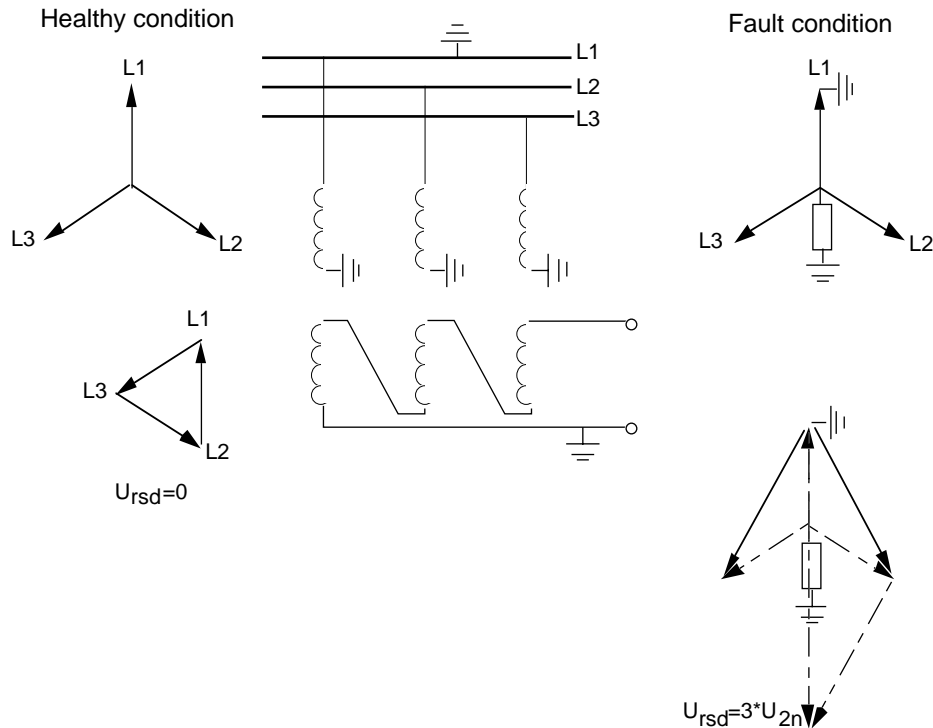

Figure 6. The principle for an open delta winding. Occurring voltages at an earth fault in a unearthed or high resistive/resonance earthed system.

## 1.4 VOLTAGE FACTOR

Voltage transformers are normally connected phase to earth. In the event of a disturbance in the network the voltage across the VT's (CVT's) will be increased in the healthy phases. IEC specifies the voltage factors:

1,9 for systems not being solidly earthed.

1,5 for solidly earthed systems.

The saturation is specified to be 30 sec for systems with tripping earth fault protection and 8 hours if no Earth fault tripping protection is used.

The VT's must not be saturated at the voltage factor.

## 1.5 BURDEN AND ACCURACY CLASSES.

A number of standard values of rated burden are given in IEC 186. Following burdens are preferred values.

10, 25, 50, 100, 200, 500 VA

---

### VOLTAGE FACTOR



# Voltage Transformers

The values are rated values per phase for a three-phase set. The standard values on burden is given at  $\cos \phi=0,8$ .

The accuracy class is fulfilled for 25-100% of rated burden.

Burden of today protection and metering equipment is very low (in range 5-10 VA for an object) and considering that accuracy class is fulfilled down to 25% only a low selected rated burden should be used.

A rated burden around 1,5\* the connected burden will give maximum accuracy at the connected burden. Refer to figure 3.

Accuracy classes are specified for protection purpose and for metering purpose. Table 1 below shows the requirement in IEC 186 for ratio and angle error for different classes.

class	meas. error e (%)	angle error (min)	purpose
0.2	0,2	10	rev. metering
0.5	0,5	20	stat. metering
1	1	40	instrument
3P	3	120	protection

*Table 1. The accuracy classes for a voltage transformer.*

It should be noted that a voltage transformer winding can be given a combined class i e 0.5/3P which means that metering accuracy is fulfilled for 80-120% of nominal voltage but the requirement for 5% of nominal voltage and the transient response requirement from protection cores is also fulfilled.

## 1.6 VOLTAGE TRANSFORMER OUTPUT

The output required from a current transformer core is dependent of the application and the type of load connected.

- Metering or instruments.

Equipment like kW, kVAr, A instruments or kWh or kArh meters measures under normal load conditions. For metering cores a high accuracy for voltages in range (80-120 %) of nominal voltage is required. Accuracy classes for metering cores are (0.1 laboratory), 0.2, 0.5 and 1.0.

---

### VOLTAGE TRANSFORMER OUTPUT

- Protection and disturbance recording.

Protection relays and Disturbance recorders where information about a primary disturbance must be transferred to the secondary side. For such windings a lower accuracy is required but a high capability to transform voltages from 5 -  $V_f^*$  rated voltage to allow protection relays measure and disconnect the fault. Protection class is 3P.

Further a good transient response is required for the protection transformers and this is a problem for CVT's where the energy stored in the capacitive voltage divider and in the interposing voltage transformer (IVT) will result in a transient voltage oscillation on the secondary side. The transient oscillation consists of a low frequency component (2-15 Hz) and a high frequency oscillation (900-4000 Hz). The time constant for the high frequency part is short (<10 ms) whereas the low frequency part has long time constants. The amplitude is decided by the fault inception angle. Higher capacitances in the voltage divider gives lower amplitude of the low frequency oscillation. The IEC 186 states that the secondary value, one cycle after a solid short circuit shall be lower than 10%.

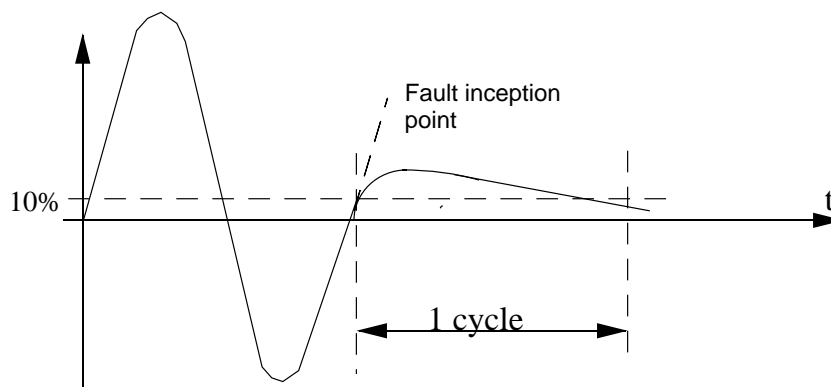

Figure 7. The transient voltage at a solid short circuit on the terminals of a Capacitive voltage transformer.

## 1.7 FERRO RESONANCE

Ferro resonance can occur in circuits containing a capacitor and a reactor incorporating an iron core (a non-linear inductance). Both the CVT and a magnetic VT can be involved in Ferro-resonance phenomenon.

---

### FERRO RESONANCE

# Voltage Transformers

## Ferro resonance in a magnetic VT

The ferro resonance for a magnetic VT is an oscillation between the inductance of the VT and the capacitance of the network. Ferro resonance can only occur at ungrounded networks, but note the risk that some part becomes ungrounded under certain circumstances.

An oscillation is normally triggered by a sudden change in the network voltage. Ferro resonance phenomenon can occur both with sub-harmonic frequencies or with harmonic frequencies.

Generally it is difficult to state when a risk of ferro-resonance occurs but as soon as a system with a voltage transformer is left ungrounded under some circumstances, preventive actions should be taken (also consider the risk of capacitive charged systems with a VT).

The damping of ferro-resonance is normally done with a 27-60  $\Omega$ , 200 W resistor connected across the open delta winding. The resistor value should give a current as high as possible but a current below the thermal rating of the voltage transformer.

## Ferro resonance in a capacitive VT

The CVT with its capacitor and IVT is by itself a ferro-resonance circuit. The phenomena is started by a sudden voltage change. A sub-harmonic oscillation can be started and must be damped to prevent damage of the transformer.

The IEC standard specifies that CVT's must be provided with ferro-resonance damping devices. Normally this consists of a saturating reactor and a resistor in each phase.

## **1.8 FUSING OF SECONDARY CIRCUITS**

Secondary fuses should be provided at the first box where the three phases are brought together. The circuit before the first box from the terminal box is constructed to minimize the risk of faults in the circuit. Any fuse in the terminal box is preferable not used as the voltage transformer supervision is difficult to perform then and the fuses in the three phase box is still provided to enable a fusing of the circuits to different loads like protection and metering circuit.

---

### FUSING OF SECONDARY CIRCUITS

The fuses must be selected to give a fast and reliable fault clearance also for a fault at the end of the cabling. Earth faults and two-phase faults should be checked. Refer to figure 7.

## 1.9 VOLTAGE DROP IN SECONDARY CABLING.

The accuracy of a voltage transformer is specified on the secondary terminal. The voltage drop and angle error in the secondary cabling must thus be checked in order to confirm the total accuracy of the circuit.

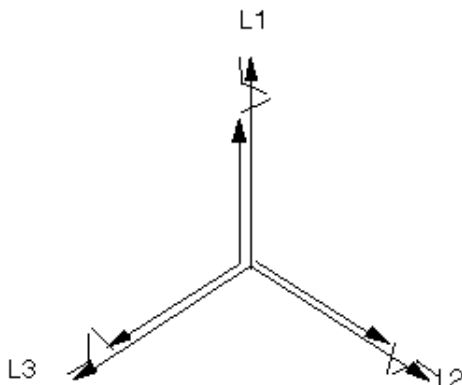
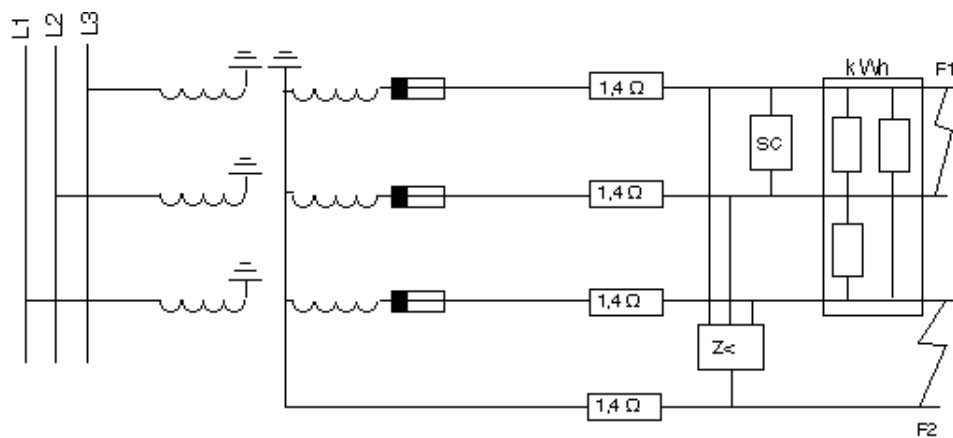

Figure 8. The voltage drop for a voltage transformer secondary circuit.

The voltage drop and angle error in the secondary cabling should be lower than the error given by the class specification of the transformer.

---

## VOLTAGE DROP IN SECONDARY CABLING.

# Voltage Transformers

---

VOLTAGE DROP IN SECONDARY CABLING.

---

## VOLTAGE DROP IN SECONDARY CABLING.

# CT Requirements

## 1. INTRODUCTION

Many types of protection relays are used in a power system. Differential protection relays, distance protection relays, overcurrent protection relays of varying types etc. will all have different requirements on the current transformer cores depending on the design of the individual protection relay.

Instantaneous and delayed protection relays will also have different requirements. A DC component of the fault current need often to be considered for the instantaneous types of protection relays.

Modern solid-state protection relays, of static or numerical types, provides a much lower burden on the current transformer cores and often also have lower requirements on the core output as they normally are designed to operate with saturated CT cores which was not the case for the old types of electro-mechanical relays

Hereafter follows a briefing of requirements that modern ABB solid state protection relays will set on current transformer cores. For special types we further refer to manuals for the respective relay and to tests of behavior at saturated current transformers performed with the different products.

To explain the general expressions used we will show a normal current transformer circuit.

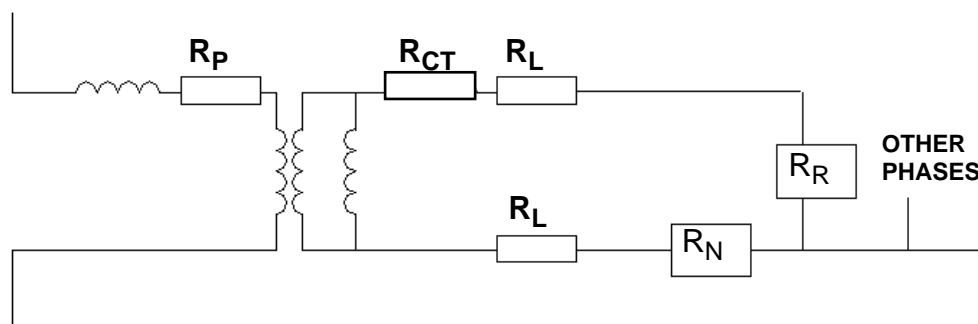

Figure 1. The current transformer principle circuit with magnetizing reactance and secondary resistance.

---

## INTRODUCTION

For phase to phase faults the loop-resistance will include the cable resistance “ $R_L$ ” plus the resistance of Phase measuring relays “ $R_R + R_{CT}$ ”.

For phase to earth fault loops the resistance will include two times the cable resistance “ $R_L + R_L$ ” plus the total resistance of Phase and Neutral measuring relays “ $R_R + R_N + R_{CT}$ ”.

Core voltage output can either be the knee-point voltage, if known, or the secondary voltage output “ $E_2$ ” calculated with help of 5P or 10P data, ALF and the secondary resistance according to:

$$E_2 = ALF \times I_n(R_{CT} + R_n)$$

where

“ $E_2$ ” is the secondary limiting emf

“ $I_n$ ” is the CT rated secondary current

“ $R_{CT}$ ” is the CT secondary resistance at 75°C and

“ $R_n$ ” is the CT rated burden, calculated as resistance.

Normally, modern relays provides a pure resistive burden.

Of course values given in ANSI, or other standards, can be used in similar ways to calculate the cores secondary output and the achieved value can be used instead. The differences in the voltage output at selected definition of core is of size some 10-20% and is not of importance for the calculation.

## 2. OVERCURRENT PROTECTION RELAYS

Overcurrent relays are used both as short-circuit and earth-fault protection. They can be instantaneous or delayed, definite- or inverse time. Current transformer cores must give sufficient output to ensure correct operation.

---

### OVERCURRENT PROTECTION RELAYS



# CT Requirements

The required CT core output is given below:

**INSTANTANEOUS PROTECTION** Core shall not saturate for an AC current, smaller than “ $2xI_{set}$ ”. The DC component doesn't need to be considered as ABB overcurrent relays are designed with short impulse limit time to secure operation also when only a very short current pulse is achieved due to heavy saturated current transformer cores. Due to high setting of instantaneous stages the requirement often will be quite high.

**INVERSE TIME DELAYED OVERCURRENT PROTECTION RELAYS** Core may not saturate for an AC current less than “ $20xI_{set}$ ”. The 20 times factor is required to ensure that the inverse time characteristic will be correct and no extra delay will be introduced in some relay (due to saturation in a CT core). Such a delay would mean a lack of selectivity. If required, the factor 20 can be changed to “the Maximum fault current of interest for selectivity divided by the Set current”.

**DEFINITE-TIME DELAYED OVERCURRENT PROTECTION RELAYS** Core may not saturate for a current “I” less than “ $2xI_{set}$ ” to secure operation.

The current output is calculated:

$$I = \frac{E_2}{R_{Loop}}$$

Both phase and earth-faults values should be checked when earth fault currents are high. Normally however the short circuit protection will give the highest requirement.

Overcurrent relays have moderate requirement on accuracy. 5P or 10P class according can be used without problems. If a low accuracy class is used this should be considered when selecting the setting. Especially the margin should be increased for earth faults when the summation of the three phases is done as the measuring error is increased when several current transformer cores are involved.

---

## OVERCURRENT PROTECTION RELAYS

### 3. IMPEDANCE AND DISTANCE PROTECTION RELAYS

#### Distance protection relays

Distance protection is an instantaneous impedance measuring protection for MV and HV power lines. The general requirement on current transformer cores which can be used for ABB Distance protection relays, of modern static and numerical type, is that the core may not saturate within 50 ms for a fault at the end of zone 1. Differences of acceptable saturation time between different relay types exists but a use of 50 ms is generally suitable. For detailed information about the requirement we refer to the manual of each relay. Saturation is allowed for internal faults as the relays are designed to operate with saturated CT core without any delay in operation. Saturation due to the DC component must be considered due to the instantaneous operation of the protection.

The empiric formula for a CT free from saturation is:

$$E_2 = I_{s1}(X/R+1)(R_{CT}+R_L) \quad \text{where}$$

" $I_{s1}$ " is the current through the own line for a fault at set reach of zone 1 and " $I_{s1}$ " is calculated as:

$$I_{s1} = \frac{U}{\sqrt{3} \times Z_s}$$

where

$Z_s$  is the total impedance for a fault at zone 1 reach.

$X/R$  is the ratio of  $X/R$  up to the zone 1 reach.

$R_{CT}+R_L$  give the secondary resistance of the current transformer core and the connected burden to the current transformer terminal.

To calculate the required output voltage for a saturated free voltage the following formula can be used. The secondary time constant is then considered to be high and the influence neglected:

$$E_2 = I_{s1} \left( T_1 \times w \left( 1 - e^{-\frac{0.05}{T_1}} \right) + 1 \right) (R_{ct} + R_1)$$

---

#### IMPEDANCE AND DISTANCE PROTECTION RELAYS

# CT Requirements

where

$\tau_1$  is the primary time constant.

## 4. DIFFERENTIAL PROTECTION RELAYS

There are many types of Differential protection relays used for many different applications. Here follows a summary of the most commonly used differential relays from ABB.

### High impedance protection relays.

CT cores used together with high impedance protection must all have identical turn ratio. Turn correction is not allowed. Normally separate cores must be provided for this kind of protection on all involved current transformers. However sometimes high impedance type of relays at Restricted earth fault protection application can be used on the same core together with the Transformer differential protection if interposing CT:s, or insulated input transformers, are provided.

All cores must have a saturation voltage  $U_{sat}$ :

$$U_{sat} > 2U_r \text{ to ensure operation at internal faults.}$$

Relay operating voltage  $U_r$  is calculated as:

$$U_r > I_{smax} (R_{ct} + R_{Loop}) \text{ where}$$

$I_{smax}$  is the max secondary through fault current and

$R_{Loop}$  is the max loop resistance seen from connection point.

Two-way cable resistance must normally be used but for applications as pure phase fault protection single way cable resistance can be used.

### Transformer differential protection.

Transformer differential protection relays are percentage restraint differential protection relays. The operation level is increased at through faults to ensure stability even with the tap changer in an end position and with differences between high and low voltage CT cores. Generally the CT cores should not saturate for any

---

## DIFFERENTIAL PROTECTION RELAYS

through fault but the percentage stabilization and an internal stabilization for current transformer saturation means that the requirement can be limited.

Following formula should be used:

$$E2 \geq K_{TFX} I_{smax} (R_{ct} + R_{Loop}) \text{ Where}$$

$K_{TF}$  is the transient overdimensioning factor

$I_{smax}$  is the max secondary through fault current and

$R_{Loop}$  is the max loop resistance seen from connection point.

$K_{TF}$  should be selected dependent of the type of Protection relay supplied and the application.

$K_{TF} = 2$  should be used for RADSB with interposing CT's.

$K_{TF} = 3$  should be used for RADSB without interposing CT's or RET 521 Differential protection function.

$K_{TF} = 4$  should be used for SPAD 346 or RET 316.

For one- and a half, Ring busbar or two breaker arrangements separate stabilizing inputs shall always be used for CT's where through fault currents can occur.

The modern relays are designed to operate correctly for heavy internal faults also with saturated CT's so the through fault condition to ensure that stability is achieved for outer faults will be dimensioning for the involved cores. It is advisable to use as similar saturation level (in current) for the involved current transformers.

Accuracy class 5P according to IEC185, or similar accuracy class in other standards, should preferable be used.

### **Pilot wire differential relay RADHL**

RADHL operates with a circulating current in the pilot wires. Current transformer cores must be provided with the same ratio at the two terminals but don't need to be of the same type. The CT accuracy requirements are based on the most severe external fault under symmetrical current conditions. Under these conditions and with the CT burden composed of the CT secondary and lead resistances, plus an allowance of 5 VA for the largest single

---

## DIFFERENTIAL PROTECTION RELAYS

# CT Requirements

phase burden of the RADHL summation CT, the CT shouldn't exceed 10% accuracy

This gives an expression

$$I_s = \frac{E_2 - E_z}{R_l + R_{ct} + R_{sct}}$$

where “ $I_s$ ” is the maximum secondary AC fault current, “ $E_2$ ” is the CT:s secondary voltage with 10P (or 5P) accuracy and “ $E_z$ ” is the voltage across the regulating diodes reflected to the primary side of summation CT.

For 1A RADHL at ph-ef faults, “ $E_z$ ” is 0.7 V and for 1A RADHL at ph-ph faults “ $U_z$ ” is 3.9 V

For 5A RADH, at ph-ph faults “ $E_z$ ” is 0.15 V and for 5A RADHL at ph-ef faults “ $U_z$ ” is 0.78 V

“ $R_l$ ” is the cable resistance (one way for ph-ph and two way for ph-ef faults), “ $R_{ct}$ ” is the CT:s secondary winding resistance and “ $R_{sc}$ ” is the summation CT resistance, reflected to the primary side of the summation current transformer, 0.2  $\Omega$ .

When so selected no saturation due to DC component in asymmetrical fault currents will cause maloperation. Neither will CT:s that saturates during an internal fault, due to AC or DC, prevent operation. General prudence suggests a limitation of the maximum fault currents to 100 times nominal current or 250 A secondary which ever is the smallest.

When current transformers of similar characteristic are provided at both ends of the line the through faults will always saturate the current transformers equal at both ends and smaller cores can then be used.

The formula:

$$E_2 \geq 20 \times I_n (R_{CT} + R_l + R_2 + 5/I_{n2})$$

---

## DIFFERENTIAL PROTECTION RELAYS

should then be fulfilled, where:

$R_2$  is the load of other equipment connected to the same core.

$R_1$  is cable resistance (one way for ph-ph and two way for ph-ef faults. If earth fault current is low only one way is sufficient).

### **Busbar differential protection type RADSS or REB 103 and pilot wire differential protection RADSL**

RADSS/L and REB 103 are moderate impedance restraint protection relays which due to extreme speed and restraining characteristic is independent of CT saturation for both internal and external faults.

To secure operation at internal faults the CT secondary limiting emf " $E_2$ " or the CT knee-point voltage is:

$$E_2 \geq 2U_{rs} = I_{d1}(R_{dt} + 28) + n_d V_{d3}$$

where

" $I_{d1}$ " is the RADSS/L, REB103 operating current

" $R_{dt}$ " is the total differential circuit resistance

" $28 \Omega$ " is the secondary winding resistance of the aux CT in the differential circuit, referred to the primary side and

" $n_d V_{d3} = 20V$ " is the forward voltage drop at the full wave rectifier in the aux CT at the differential circuit secondary side.

### **Loop resistance**

The permissible loop resistance for secure through fault stability seen from the relay is:

$$R_{lx} = R_{dt} \times S / (1 - S)$$

where

" $S$ " is the setting of the slope

" $R_{dt}$ " is the total differential circuit resistance and

$$R_{dt} = n_d^2 \times R_{d3} + R_{md} + (R_a \times R_{d11})$$

where

" $n_d$ " is the turns ratio of the aux CT in the differential circuit and is 10,

---

## **DIFFERENTIAL PROTECTION RELAYS**

# CT Requirements

“ $R_{d3}$ ” is the resistance of the fixed resistor set to  $11 \Omega$ ,

“ $R_{md}$ ” is the short circuit impedance of the aux CT in the differential circuit set to  $350 \Omega$ ,

“ $R_a$ ” is the resistance of the alarm relay set to  $20 \Omega$  and

“ $R_{d11}$ ” is the resistance of the variable resistor

The loop resistance seen from the relay is:

$$R_{lmax} = (R_2 + R_l) \times n_{mx}$$

where

“ $R_2$ ” is the main transformer secondary resistance,

“ $R_l$ ” is the cable loop resistance and

“ $n_{mx}$ ” is the aux transformer ratio.

## 5. FAULT LOCATORS

### Fault locator type RANZA.

Requirement on current transformer cores used for ABB Fault locator RANZA is that the core is not allowed to saturate within 30 ms from the fault inception for a fault at a location where the maximum measuring accuracy is required.

The formula for saturation free CT in 30 ms is:

$$E_2 = K_{tf}(R_{ct} + R_l)$$

The transient dimensioning factor “ $k_{tf}$ ” =  $\emptyset_{max} / \emptyset_{ssc}$

The flux at 30 ms,  $\emptyset(0,03)$  is:

$$\emptyset(0.03) = \emptyset_{ssc} \left( \frac{wT_1T_2}{T_1 - T_2} \left( e^{-\frac{0.03}{T_1}} - e^{-\frac{0.03}{T_2}} \right) + 1 \right)$$

where

“ $T_1$ ” is the primary net time constant in seconds,

---

## FAULT LOCATORS

“ $T_2$ ” is the secondary time constant in seconds,

“ $\Phi_{SSC}$ ” is steady state flux corresponding to the sinusoidal current and

“ $\omega$ ” is the angle speed i.e.  $2\pi f$  where “ $f$ ” is the net frequency.

For conventional CT's with a high “ $T_2$ ” compared to “ $T_1$ ” this can be simplified:

$$E_2 = I_{s1} \left( T_1 \times \omega \left( 1 - e^{-\frac{0.03}{T_1}} \right) + 1 \right) (R_{ct} + R_1)$$

where

“ $I_{s1}$ ” is the max fault current for which the accuracy is required,

“ $R_1$ ” is the loop resistance seen from core terminals,

CT ratio must be selected to ensure that phase component of the fault current always is bigger than 10% of rated current).

Accuracy class 5P according to IEC185 should preferably be fulfilled.

### **Fault locator in Distance relay type REL100 or REL 511, REL 521 or REL 531**

The built-in fault locator option in the Line protection terminals as above is designed with the same measuring algorithm as in fault locator type RANZA. The time window for measurement is however shorter and therefore a time to saturation for a fault at location where maximum accuracy is required of 20 ms can be used.

Similar formula as for RANZA, but with 20 ms instead of 30 ms, should thus be utilized.

Normally it's sufficient to use cores suitable for the Distance protection without special check. However, when lines are long and requirement on cores from Distance protection low, a high accuracy can be required for faults much closer to the station. Then the requirement set by the Fault locator will often be dimensioning although the time to saturation allowed is much shorter.

A certain saturation can also be accepted without loss of measuring accuracy due to the analogue and digital filtering of current

---

## **FAULT LOCATORS**



# CT Requirements

signals. There is also a possibility to recalculate the result given by the fault locator in above products using a different measuring loop if a heavy DC saturation is noticed in some of the involved phases. This can give a big improvement as the DC component will always differ between phases for multi-phase faults.

## 6. BREAKER FAILURE RELAY TYPE RAICA

The requirement on a core feeding a Breaker failure relay RAICA is:

$$E_2 \geq 15 \times I_{\text{set}}(R_{\text{ct}} + R_1)$$

or:

$$E_2 \geq 0.2 \times I_n \times n(R_{\text{ct}} + R_1)$$

whichever is the biggest.

where

" $R_{\text{ct}}$ " is CT secondary resistance,

" $R_1$ " is the total loop resistance seen from CT terminals,

" $I_{\text{set}}$ " is the RAICA set current,

" $I_n$ " is the CT secondary rated current and

" $n$ " is maximum primary fault current/CT primary rated current.

This will secure the operation of the Breaker failure relays even with CT saturation. RAICA is designed with a energy storing to give a continuous energizing of the output, even with heavy saturated current transformers, and with short reset pulses every cycle caused by the extreme speed of the measuring relay RXIB.

---

### BREAKER FAILURE RELAY TYPE RAICA

---

## BREAKER FAILURE RELAY TYPE RAICA

# Control System Structure

## 1. INTRODUCTION

The control system equipment in a Substation is a vital part that supervises, protects and controls the transmission of electrical power.

The increasing complexity in the substations of today, together with the increasing transmitted power and the increasing fault current levels, means increasing requirement set on the control and protection equipment.

Dependent of the stations location in the networks and the power consumption, the operation and maintenance organization of the customer and government regulations etc., many choices must be done in order to achieve lowest possible Life Cycle Cost (LCC).

The highest possible service reliability is a general goal. Flexibility and maintainability are also important factors in order to attain a total reliability.

The first choices are the selection of the primary apparatus. The choice of AIS or GIS switchgear and decision of the switchgear arrangement, to be used and transformer sizes etc. are important in order to achieve a low LCC.

Thereafter choices of control and protection equipment must be done e. g. conventional or computerized control equipment, single or redundant protection systems, design and voltage of battery system, choice of battery type etc. All choices must be done with the expected future development in mind. Later changes will always mean a much higher cost than a selection made after future needs.

It's always difficult to foresee the future but a summary of expected changes of the power network in the area of the new station should always be done e.g. by checking plans for building of new living areas, starting of new industries etc., with the communities.

---

## INTRODUCTION

The cost distribution for a construction of a typical Substation is shown in Figure 1. It should be noted, that the control and protection equipment is about 10-15% of the stations total cost. If transmission lines also are included in the comparison the cost part of control and protection will be even smaller.

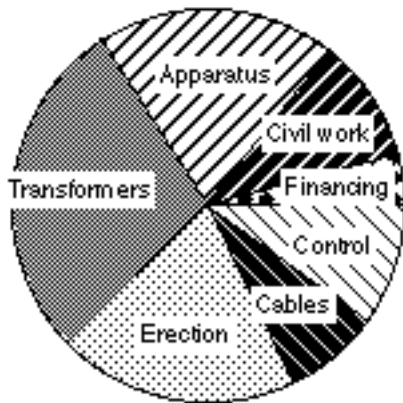

Figure 1. The cost distribution at installation of a HV substation.

The importance of control and protection equipment is expanding if the total life cycle cost is considered. The control equipment is very important for the station operation and the protection equipment is an important part of the maintenance and thus the maintenance cost.

In most organizations a number of standards has been selected and must be followed. Government also has a number of requirements which must be followed by the station owner. A standard can often mean a high initial cost but will give a positive impact on the life cycle cost, as the maintenance personnel will be more efficient as they are well familiar with the equipment. The spare part cost will also be lower.

In this document a survey of different parts of the control and protection equipment is done. Equipment included in the control system are:

- Auxiliary power systems.
- Protection system.
- Metering equipment.
- Control and regulation.
- Signalling and event recording.
- Operation.

---

## INTRODUCTION

# Control System Structure

## 2. INSTRUMENT TRANSFORMERS

### 2.1 CURRENT TRANSFORMERS

#### **Location**

The location of the current transformers will give the limitation of the protection zones.

The most common approach is to locate the current transformer at the outside of the object circuit breaker, so that a Busbar differential protection will cover the circuit breaker.

The location should generally be as close as possible to the circuit breaker as the breaker will open when a fault is detected. The zones where an incorrect tripping is achieved is thereby minimized.

For GIS switchgears a requirement to cover all GIS compartment from the busbar protection is often raised. This will ensure an instantaneous trip for all faults in the GIS and the risk of “burn-through” is thereby minimized.

For lower voltages where busbar protection is not used, a location of the current transformer to between the breaker and the busbar could be advantageous but is usually impossible to do due to the mechanical construction.

When Transfer busbars, C-arrangements, are used a location of current transformers outside the C-disconnector is preferred. The object protection will then still be in operation when the transfer busbar and transfer breaker is used to by pass another break-

er scheduled for maintenance and a rearrangement of the trip circuit to the transfer breaker can simply be done (see Figure 2).

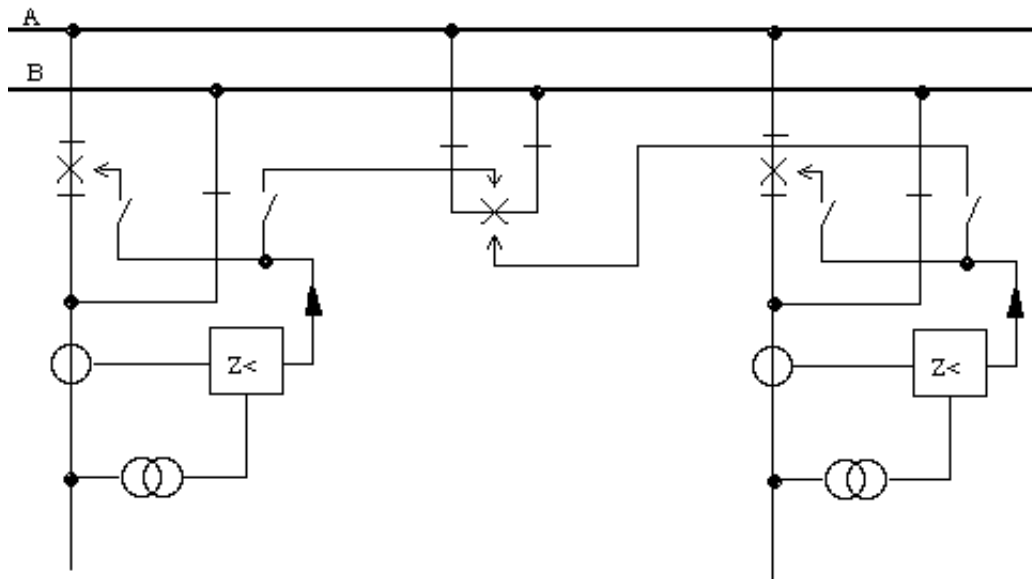

Figure 2. The location of current transformer at a AC-Busbar arrangement.

At one and a half breaker systems and double breaker systems, the current transformers in the two sections are connected together in a summation. Similar core data on the involved cores will match each other when the cores are summed.

A control of possible primary current loops through the current transformer must be done, when circuit breaker is earthed on both sides. Resistance of primary loop is seen as the current transformer ratio in square times the primary loop resistance from the secondary side. A fault or load current in the other (summed) current transformer will thus be split up between protection/meters and the primary loop according to the impedances in the two circuits.

Especially for CT:s with low ratio, primary resistance seen from secondary side could be quite low, leading to an important measuring error for the metering and fail to trip for a primary fault. This is due to the fact, that a part of the load/fault current will create a primary circulating current instead of going through the meter/protection. For high impedance protection schemes this

---

## INSTRUMENT TRANSFORMERS

# Control System Structure

could be a problem even with not so low CT-ratio and must be checked. (See Figure 3)

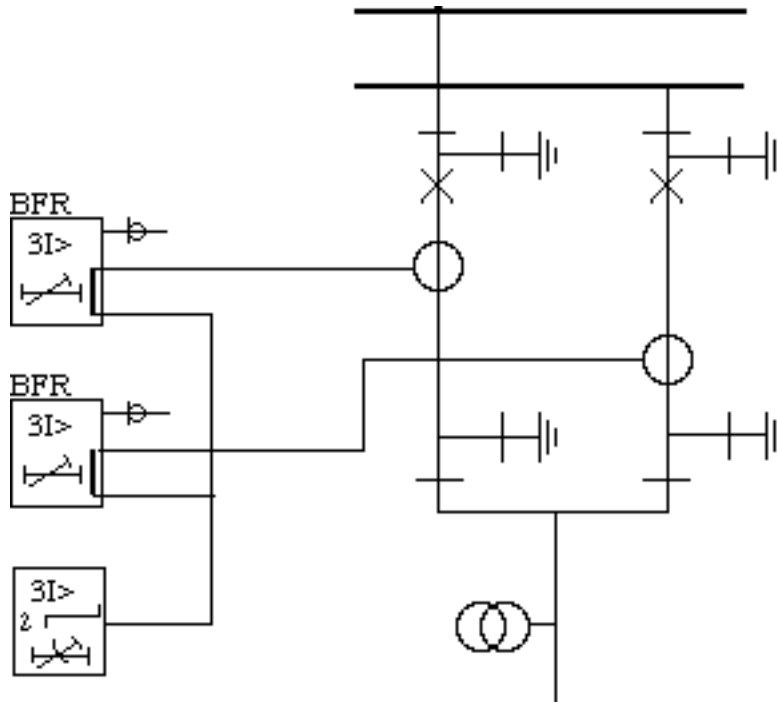

Figure 3. Summation of current transformers in a double busbar arrangement.

## Earthing

To prevent dangerous potential in the secondary circuit of a current transformer all secondary circuits shall be earthed.

Only one earthing point may be used when several current transformers are connected together in a summation or differential connection. This is necessary as equalizing currents else can flow through the circuit, during a primary earth fault.

Neutral connection and earthing can be made according to varying practises in different countries and with different utilities.

Earthing towards the protected object and neutral connection are the most common principles followed by most companies and manufacturers of protection and metering equipment.

Within ABB Substations we follow the principles:

- Neutral and earth towards protected object.
- Neutral and earth toward the metering direction.

---

## INSTRUMENT TRANSFORMERS

## **Reconnected CT's.**

Primary as well as secondary reconnection is used.

At primary reconnection there are two primary windings, usually only one turn each, which are connected in series or in parallel. Independent of the connection the same core data will be achieved.

Secondary reconnected cores has taps on the secondary winding. The core data will then be, as best, linearly reduced. Due to the reduction of core data a difference between maximum and minimum tap, higher than 1:2 should be avoided as the secondary circuit burden is always the same.

Secondary taps not used shall be left open.

Cores not used shall be short-circuited at maximum taps.

An open current transformer secondary circuit will mean dangerous voltages and must therefor be avoided carefully.

## **Terminals**

To enable a simple testing and reconnection of current circuits at commissioning/fault finding a terminal grouping as in Figure 4) can be used. A simple change of current direction is achieved by changing the link. A simple test of each core can be done from the terminals. The terminals are openable with links and should be suitable for connection of normal test wires.



# Control System Structure

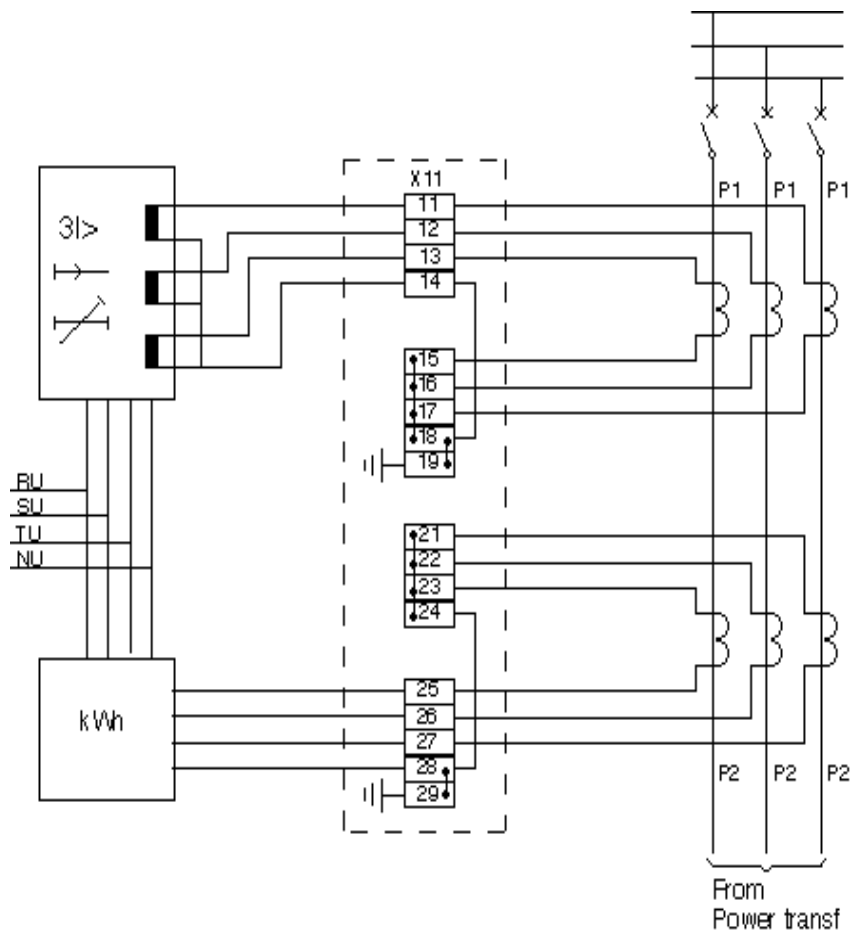

Figure 4. A terminal arrangement which allows simple reconnection of a current transformer direction and a simple testing of each core.

## 2.2 VOLTAGE TRANSFORMERS

### Location

The location of the voltage transformers will primary depend on the switchgear arrangement, the protection, the metering and the automatics connected.

Normally, voltage transformers connected to the busbars and at the low voltage side of the transformers are satisfactory in a distribution substation.

Directional Protection on outgoing bays are then fed from the busbar VT:s.

---

## INSTRUMENT TRANSFORMERS

On the transmission voltage level the protection equipment will normally require voltage transformers at all objects, sometimes with exception of the HV side of power transformers.

Further, a single phase set is located at the busbars for voltage, frequency and synchronizing purpose. This avoids complex voltage selection schemes.

### **Earthing and fusing.**

The secondary circuits are fused and earthed in the VT marshalling box. This will ensure that dangerous voltages will not occur. Connection of different VT/CVT circuits should therefore be avoided to prevent equalizing currents in the secondary circuits during primary earth faults.

The fusing can be done with diazed fuses or Miniature circuit breakers (MCB:s). The tripping condition must be checked i.e. it must be checked that the fuses/MCB will trip within a reasonable time (e.g. 5 sec). This normally means that higher rated currents than 6 A cannot be used.

### **Supervision**

A fault can always occur even if the plant is well designed and well constructed. When a fault occurs it's of importance that the fault is immediately detected and an alarm given to enable the maintenance personal to quickly repair the fault. A fault in a metering circuit will mean incorrect metering, with loss of income as a result. A fault in a protection circuit can mean one missing or incorrect tripping which will lead to unnecessary disconnecting of one or several objects.

The supervision of a voltage transformer secondary circuit can be done according to Figure 5 if the circuit supplies metering equipment. An occurring unsymmetry between the phases will be detected and the relay can by that detect one or two phase fuse failure.

# Control System Structure

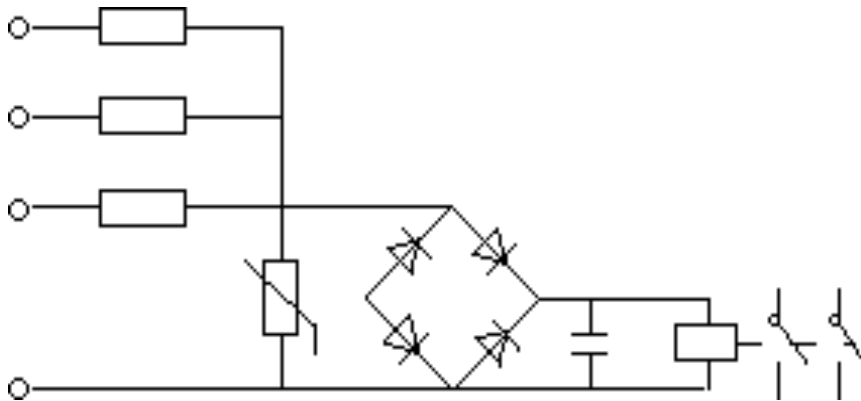

Figure 5. Supervision of a voltage transformer circuit (for alarm purpose only).

If a protection relay is supplied a supervision according to Figure 6 can be used. A differential voltage measuring is used where the voltage of a main fuse, supplying the protection relay, and a pilot fuse are compared. This principle will detect one, two or three phase fuse failures.

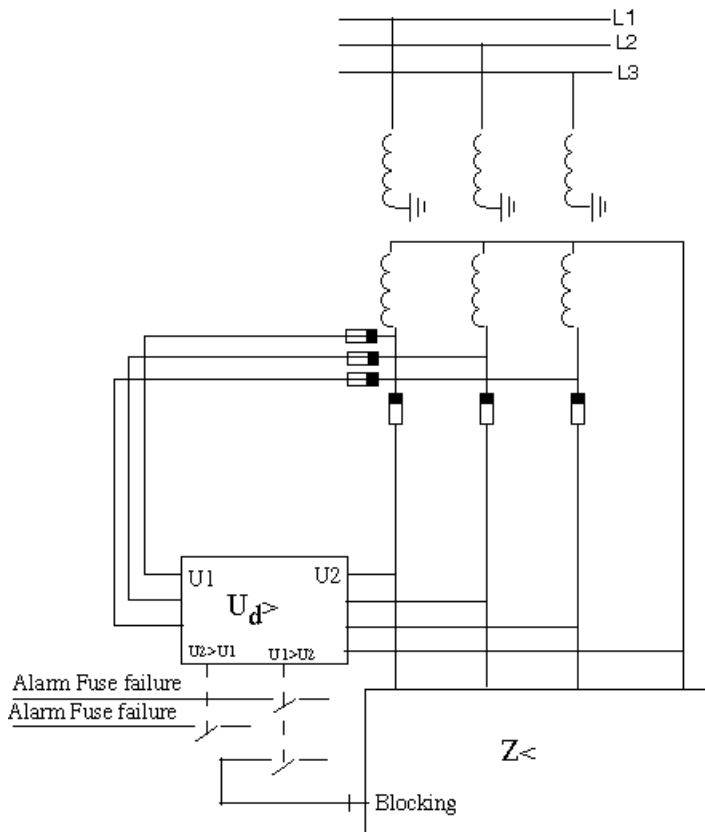

Figure 6. Supervision of a Voltage transformer secondary circuit (for blocking of protection).

## INSTRUMENT TRANSFORMERS

Another solution used to detect fuse failures in some types of Distance protection is to compare the occurrence of zero, or negative, sequence voltage with the occurrence of zero, or negative, sequence current. If only voltage occurs the problem is a blown fuse. If both current and voltages occur there isn't a fuse problem but a primary earth fault. The drawback with this principle is that it will only detect one and two phase fuse failures. However the normal faults on a voltage transformer circuits are to earth and in rare cases between two phases.

If MCB:s are used an auxiliary contact can be used to give alarm. If Distance protection relays shall be blocked a special MCB with low instantaneous level and a very fast auxiliary contact must be used.

### **Cabling**

Dedicated cables shall be used for the voltage transformer secondary circuits. The cable shall be screened and earthed at both ends to keep the disturbance voltages to low levels.

The secondary cabling must be dimensioned to:

- Ensure that fuse/MCB will operate, in a reasonable time, for a fault at the far end of the cables.
- Keep the voltage drop, due to the burden, one level lower than the inaccuracies in the voltage transformer.

A special problem occurring in voltage transformer circuits if fuses are used is the risk of back-feeding a faulty phase from the healthy phases. This phenomena occurs when phase to phase connected load exists. The phase with the blown fuse can reach

# Control System Structure

rather high voltage level. The level is decided by the load in the different phases as indicated in Figure 7.

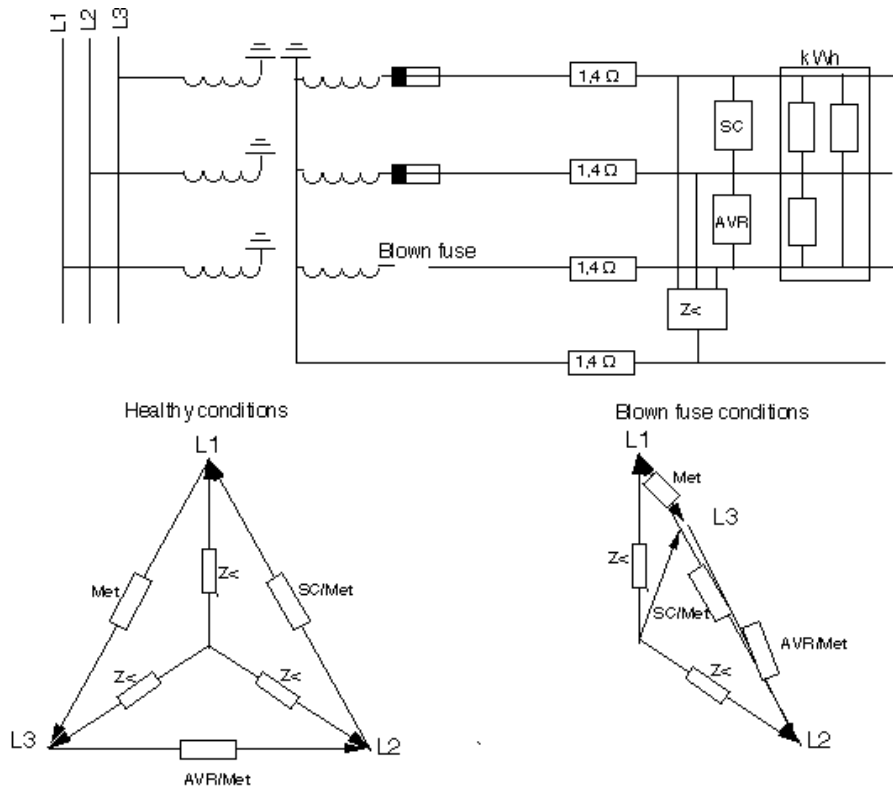

Figure 7. Back-feed of voltages to a faulty phase, when phase to phase load exists.

## 2.3 AUXILIARY POWER DISTRIBUTION

The auxiliary power system has a very central role in a substation. A fault in the battery system will mean that neither control and protection equipment nor primary equipment can fulfil their tasks. Often a complete station or a big part of a station is influenced by a main problem in the auxiliary power system.

At higher system voltages, two battery systems are mostly provided to feed the local back-up protection, in redundant protection systems.

At lower voltages this is not necessary as a protection system with remote back-up normally is used. This means that faults can be detected from another location as well.

## INSTRUMENT TRANSFORMERS

The DC distribution ensures that protection relays which are providing back-up to each other (e.g. outgoing feeder and transformer protection) are fed from different main fuses in the battery distribution. This will ensure that minimum possible part is tripped at a primary fault even with a single failure in the fault clearing chain, as in this case, in the battery system.

The supervision of a the auxiliary power supply is of utmost importance. The secured feeding of alarm circuits for DC problems must be ensured.

A well designed supervision of the DC supply to an object should supervise the feeding fuse, an open circuit and a blown fuse/MCB in the sub distribution.

An example of a DC supervision is shown in Figure 8. It's often a good idea to include the contacts of the DC/DC converters in the different protection relays in the supervision, so that a common alarm is given when DC problems anywhere in the distribution occurs.

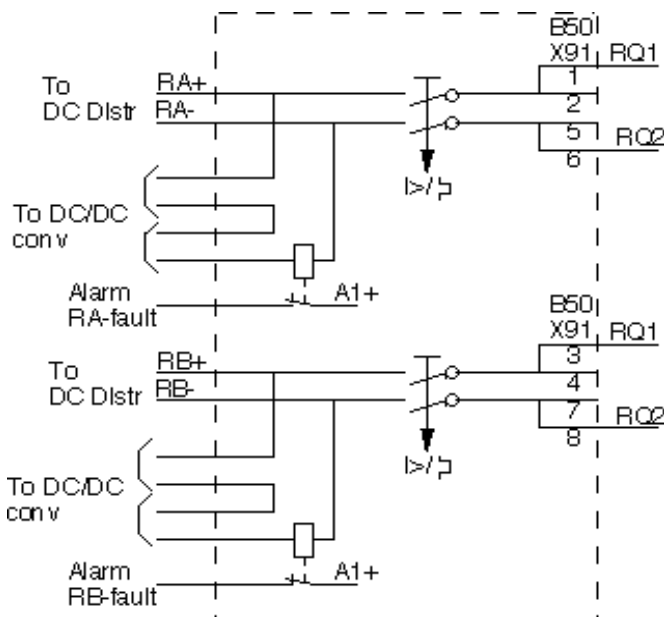

Figure 8. Supervision of the DC supply to a protection panel, detecting faulty supply fuse, open circuit and DC/DC converter failures.

### Supply of different equipment

Varying principles are used in the auxiliary power supply of the equipment.

---

## INSTRUMENT TRANSFORMERS

# Control System Structure

An important principle is to limit the distribution of the auxiliary power supply to the protection system as much as possible, and to use only one supply to the protection of an object and the breaker trip coil.

The limitation of the circuit distribution is done by feeding disconnector, earthing switch operation circuits and enabling circuits etc. from separate supplies.

The trip coil can in a system without redundant protection be supplied from the same supply as the protection relays and the trip coil. A closing is then not possible if the voltage supply to trip isn't available.

To simplify the fault finding at earth faults in the DC supply system a structured terminal system as shown in Figure 9 can be useful.

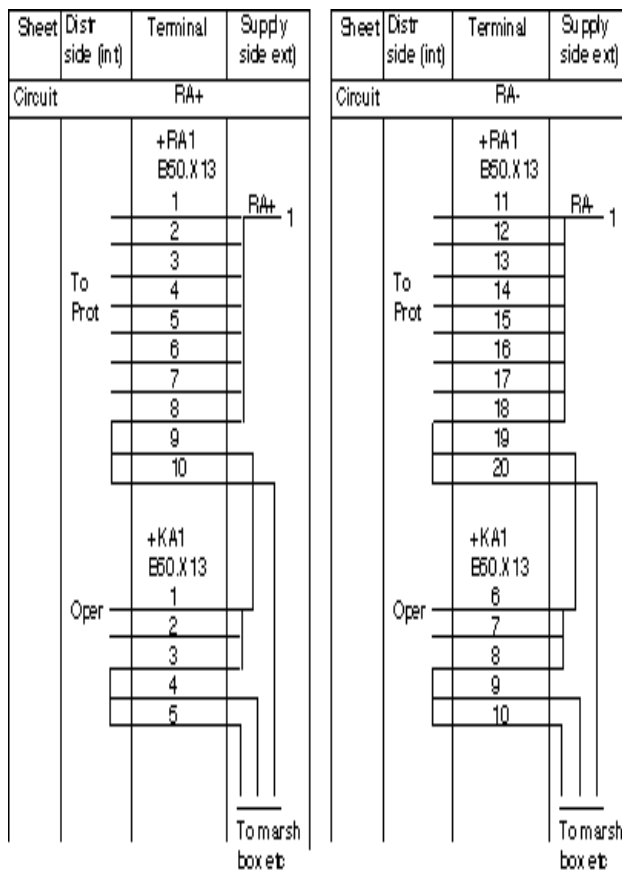

Figure 9. A terminal arrangement, enabling a simple localization of earth faults and a simple design of the DC distribution to different panels and boxes.

## INSTRUMENT TRANSFORMERS

The system includes a supply of marshalling boxes, control panels (and other panels) and internal distribution from different terminals, so that each circuit simply can be opened and checked for e. g. bad insulation. The terminal numbering system utilized is described later on.

To enable location of an earth fault, in a operation circuit, at a disconnector/earthing switch, with two pole operation, a resistor shall be connected across the contact at the negative side.

## **3. PROTECTION AND CONTROL EQUIPMENT**

### **3.1 DESIGN OF PANELS**

The panel design and construction shall be done following a number of general guidelines:

- The layout are to follow the layout of the primary switchgear to avoid confusion.
- The panels should be clearly and visible labelled, so that objects located in the panel is simply identified.
- The possibilities of future extensions should be kept in mind both in panel design and the location in the room etc.
- Maintenance should be simplified as much as possible and the design should minimize the risk of mistakes such as testing the wrong object or the need of making a lot of reconnections, to enable testing.
- Two object per panel, should be avoided but must be done out of cost reason. The belongings of the object shall then clearly be labelled both on front and inside the panel.

#### **Terminals**

The terminals are small but important components in a substation. They should have possibility to simple connect and disconnect measuring wires with a clearly visible indication.

A maximum of two cores are to be connected at each side of the terminal and a mixture of single core and stranded wires should be avoided.

At terminal numbering a clear structure should be used to improve the total quality. The design engineer will by that know

---

#### **PROTECTION AND CONTROL EQUIPMENT**



# Control System Structure

which terminal group to use for different types of circuits. Different circuits in the panel can simply be separated. The workshop testing and the site commissioning personnel will from the numbering see what circuit type they are working with e.g. they can simple differ a current circuit from a auxiliary supply circuit.

The terminal numbering system used by ABB Substations AB is shown in Appendix 1.

The system used enables a clear separation of main and back-up protection and gives an indication of interface and trip circuits which is of importance for the service and maintenance.

The system is also made for connection of cables. Cable cores are simple to erect as the connection of the different cores is in the same group. Extra terminals for future use can also simply be added with a prepared and correct number.

## **Trip circuit design**

The trip circuits are together with the DC supply key parts of the fault clearance chain.

Trip circuit supervision can be used to improve the dependability of the circuit. The circuit from the relay panel to the circuit breaker, including the auxiliary contact of the breaker is supervised by a small current (1-20 mA), fed through the circuit. Through a special circuit, with a resistor and an auxiliary contact at the breaker, the circuit can be supervised also when the breaker is open.

A double supervision where a current measuring relay is connected both in the breaker circuit and across the relay can be used when lock-out trip relays are used.

The arrangement of a trip circuit supervision is shown in Figure 10.

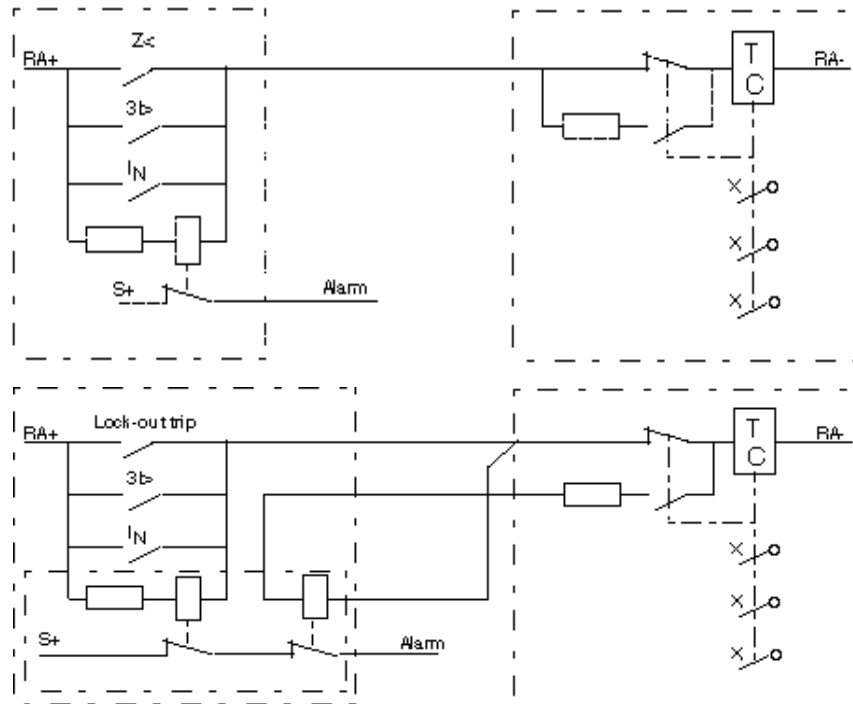

Figure 10. Arrangement of a trip circuit supervision. a) Single supervision, b) Double supervision (with lock-out trip relays).

The trip coils of the circuit breaker normally have a power need of 200-300W. A common requirement is that the contacts of the trip relays are capable of breaking the current to the trip coils even though there is an auxiliary contact in the breaker doing this. This contact will however not operate at a breaker failure and heavy duty contacts are therefore advantageous.

### Busbar protection trip circuits.

Trip arrangements for busbar protection relays can be done in different ways. The bus-principle as shown in Figure 11 is preferred, as it gives a simple and clear technical solution, where Breaker

# Control System Structure

failure trip simple can be arranged to trip the busbar, without need of extra auxiliary contact on the disconnectors.

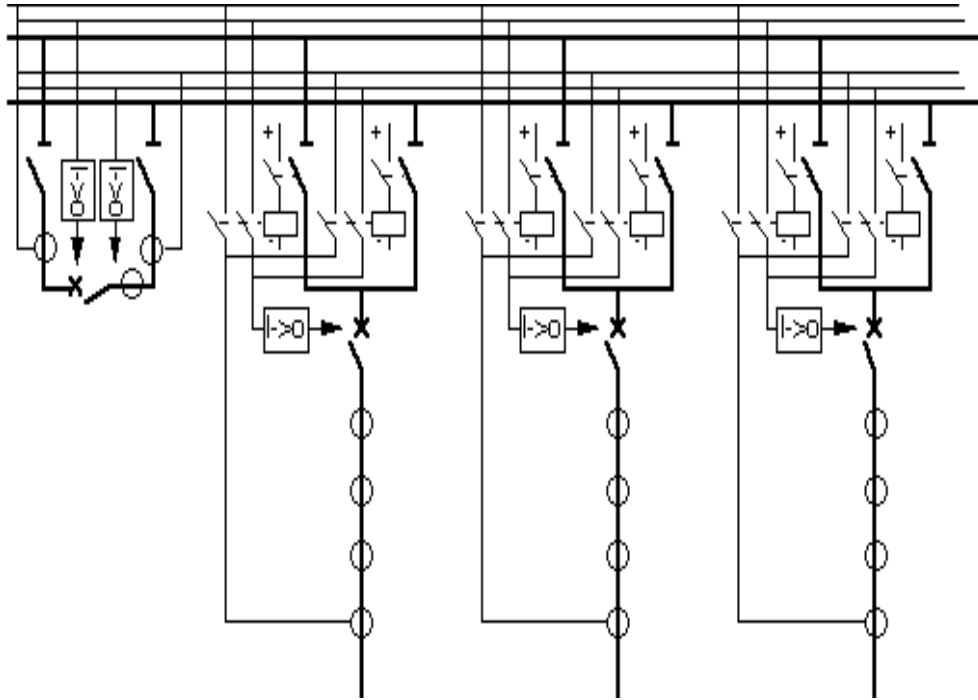

Figure 11. A trip busbar arrangement, for busbar protection tripping, gives a simple solution and allows the CBF trip to be connected without extra auxiliary circuits on the disconnectors.

## Lock out tripping.

Lock-out of circuit breaker closing should be initiated from protection relays covering faults of permanent type. Lock-out relays are reset manually, when the fault has been repaired. The best solution is to open the close circuit only. A permanent signal in the trip circuit only isn't good as the breaker then can be unnecessary initiated even though instantaneously retripped. A continuous trip will also mean problems for trip circuit supervision and special care need to be taken for this.

It should also be remembered that a Breaker trip coil cannot accept more than a short trip pulse. Long pulses will destroy the trip coils and this can happen e. g. when a Breaker has not stored energy in the operating device and the trip relay is initiated, mostly then during testing.

Lock-out should thus preferable be performed with self reset trip relays and latching relays opening the closing circuit only.

## Capacitive discharges.

Trip and important operation relays should be stable during the capacitive discharges which can occur at an earth fault in the DC system. The problem is shown in Figure 12. Special types of relays with a stabilization against this discharge are available.

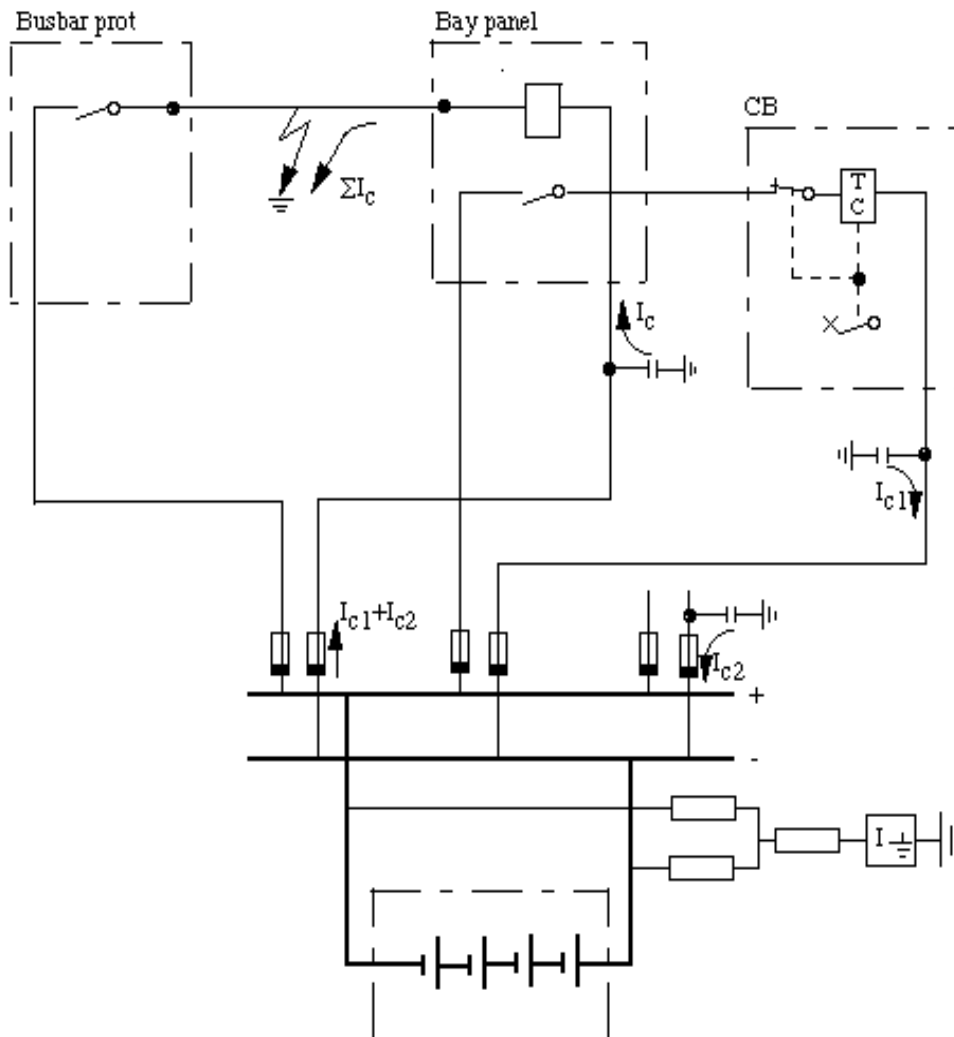

Figure 12. An earth fault in the battery system, will give capacitive discharges, which can operate trip relays. Secured trip relays should be used when the circuit is simply available e.g. in terminals.

# Control System Structure

## 4. SIGNALLING

### 4.1 FAULT SIGNALLING

At a fault in the primary network it's of importance that the operating personal receives information about fault type, whether the fault is persistent or transient, what phases are involved and the fault location so that correct actions can be taken.

At a fault in a the protection and control equipment it's of great importance that the operating personal receives information about the disturbances so that corrective actions can be taken.

These faults don't normally mean disturbance for the system service but need to be repaired within a short time.

An alarm for a fault in the battery system like a lost battery charging need to be fixed within 4-10 hours depending on the batteries capacity so that the station is not left without protection and control possibilities. A fault in the primary system would then cause unnecessary large consequence, with damaged equipment and disconnection of far to big parts of the network as a result.

Several different equipment types are used to give information about primary and control equipment faults. Among them you'll find:

- Annunciator system
- Event recorder
- Disturbance recorder
- SCADA

One important part in order to achieve a high reliability and in order to follow up disturbances in the primary system and the behavior of the protection system is the post fault analysis (see Protection - General).

---

## SIGNALLING

## **4.2 ANNUNCIATOR SYSTEM**

The annunciator system will give the operating personal quick information about a fault. At activation of an alarm point an audible alarm is initiated. This alarm is locally switched off when the station is remotely controlled.

All faults are to be alarmed but grouping in suitable groups is done to save cost and to simplify for the operator as too much information will only be confusing when a quick decision have to be taken.

## **4.3 EVENT RECORDER**

The event recorders gives digital, time tagged, information about all disturbances in the control system, as well as in the primary system.

The sequence of events such as starting of measuring zones and phase selection etc., can be followed with a resolution of some ms which simplifies the follow up on a disturbance. This follow up is performed later by experts at protection and control systems. Information at the event recorder is just to a low extent used by the operators.

## **4.4 DISTURBANCE RECORDER**

The disturbance recorder gives information about the analogue signals during a primary fault. A few digital event are also connected to get a time reference and a possibility to compare the event recorder and disturbance recorders information.

The disturbance recorder starts when any protection relay starts or trips. A pre-fault memory is included. The recording will thereby include information from just before the fault (0.1-0.5 seconds) to up to after the fault has been cleared.

Today print-outs is on regular paper but there is also a possibility to send the information in series form to a computer, as software support today is available to most types of recorders.

---

## **SIGNALLING**

# Control System Structure

## 4.5 REMOTE SIGNALLING.

Most stations in the world, are today remotely controlled, or prepared for remote control.

Locally available signals must be transmitted with high reliability to the dispatch center and to the operators. This concerns signals for faults in the primary system, as well as faults secondary in the control system.

## 5. INTERLOCKING

The interlocking system will prevent human mistakes which can lead to severe damages of equipment and/or injuries of persons.

With the development of today control system and the increasing integration of circuits it is of greatest importance to always keep the independence requirement between the operation circuits and the interlocking circuits in mind. An equipment fault must not, at the same time, cause an operation of a disconnector and an enabling signal.

Independency does not necessary mean independent hardware but the design of the circuit to achieve a highest possible reliability is important.

## 6. DOCUMENTATION

A big amount of documentation is necessary for each station in order to enable service, maintenance, fault finding, purchasing of spare parts and extensions of the station. The documentation is the output of a process starting at contract signing and ending with the Final acceptance.

The cost of design and documentation is about 20-30% of the total cost of the control system.

---

### INTERLOCKING

## Documents for different categories

The documents produced are for varying categories of personal. Erection, commissioning, maintenance and engineering departments, have all different requirements and uses different documentation in their work.

## Documents groups

The documentation can be separated in three different parts:

- Operation and Maintenance manuals, gives information about operation and maintenance of the station. General documents like Single-line diagrams, Block diagrams and User's manuals for products, are included here.
- Electrical design contains Circuit diagram, apparatus list and interconnection tables etc., and gives detailed information to commissioning and maintenance personal.
- Erection manuals includes information for mechanical construction such as mounting information for panels and apparatus, mechanical drawings etc. The erection manuals are used by the erection personal.

It is of utmost importance that the documentation is kept updated and that old versions are thrown away. An up-to-date set shall be stored at the substation.

## 7. CONCLUSION

When a control system is designed it is important to see to the goal with the substation and to check that the purpose with the document produced is clear.

A reliable plant, with a high availability, shall be simple to operate and maintain. Simple solutions are always preferred as mistakes and misunderstandings during the different stages of the project are prevented.

The documentation system has a key role as carrier of information between different departments during the different stages of the project. A well structured organization where responsibilities are known by all people is necessary to achieve a high quality and reliable plant with high availability.

---

## CONCLUSION



# Control System Structure

## 8. TERMINAL NUMBERING SYSTEM

### 8.1 RELAY PANEL, MAIN 1 PROTECTION

<b>Function Type</b>	<b>Terminal group</b>	
<b>Current circuit</b>		
Core 1 I1	X11:	11-14
Core 2 I2	(other CT:s	21-24
Core 3 I3	are called	31-34
Core 4 I4	X111 etc.)	41-44
<b>Voltage circuit</b>		
Distr 1 U1	X12:	11-19
Distr 2 U2	(other VT's	21-29
Distr 3 U3	are called	31-39
Distr 4 U4	X112 etc.	41-49
Open delta		51-59
<b>Auxiliary voltage protection relays</b>		
DC distr R2+/-	X13:	1-16
<b>PLC sign</b>	X17:	1-
<b>Sub 1-Sub 2 Interface</b>	X18:	1-
<b>Trip outputs (incl CB fail, intertrip etc.)</b>	X19:	1-

---

## TERMINAL NUMBERING SYSTEM

## 8.2 RELAY PANEL, MAIN 2 PROTECTION

<b>Function Type</b>	<b>Terminal group</b>	
<b>Current circuit</b>		
Core 1 I1	X21:	11-14
Core 2 I2	(other CT:s	21-24
Core 3 I3	are called	31-34
Core 4 I4	X121 etc.)	41-44
<b>Voltage circuit</b>		
Distr 1 U1	X22:	11-19
Distr 2 U2		21-29
Distr 3 U3		31-39
Distr 4 U4		41-49
Open delta		51-59
<b>Auxiliary voltage protection relays</b>		
DC distr R2+/-	X23:	1-16
<b>PLC sign</b>	X27:	1-
<b>Sub 1-Sub 2 Interface</b>	X28:	1-
<b>Trip outputs (incl CB fail, intertrip etc.)</b>	X29:	1-

---

### TERMINAL NUMBERING SYSTEM

# Control System Structure

## 8.3 OTHER CIRCUITS

### Control circuits

DC distr X31: 1-10

Other circuits 21-

### Annunciator circuits

DC distr X41: 1-10

Other circuits 21-

### SCADA circuits

DC distr X51: 1-10

Other circuits 21-

### Event recorder circuits

DC distr X61: 1-10

Other circuits 21-

### Fault Recorder circuits

DC distr X71: 1-10

Other circuits 21-

### DC Supply Main 1 (feeding MCB/fuse)

DC distr X91: 1-4

### DC Supply Main 2 (feeding MCB/fuse)

DC distr X92: 1-4

### AC Supply for Heaters Lighting etc.

AC distr X93: 1-10

Other circuits 21-

---

## TERMINAL NUMBERING SYSTEM

---

## TERMINAL NUMBERING SYSTEM

# Setting of Protection

## 1. INTRODUCTION

The main function of the protection system is to isolate the minimum possible part of the power system at a fault or an abnormal condition. This is achieved by selecting a protection system suitable for the plant and object protected, and to set the protection relays to suitable values. Suitable protection relays with incorrect setting can cause severe disturbances of power supply and/or unnecessary damage of equipment.

Faults occurring in the power system should always be detected by two different protection relays to allow for a single failure. (Fuses are “secure break points” and do thus not require back-up protection). The protection relays are normally designated Main and Back-up protection.

According to IEC it is the MAIN PROTECTION that is normally expected to take the initiative in cases of a fault in the protected zone. The BACK-UP PROTECTION is provided to act as a substitute for the main protection in case of failure or inability of this to perform its intended function.

The protection system shall, as mentioned before, be able to isolate minimum possible part of the system. We can then introduce the term SELECTIVITY.

SELECTIVE PROTECTION is a protection which determines that the fault is within its zone and isolates that zone only. Selective protection relays can be ABSOLUTE SELECTIVE or RELATIVE SELECTIVE.

ABSOLUTE SELECTIVITY is when a protection responds only to faults within its own zone.

Examples of ABSOLUTE SELECTIVE protection relays are:  
Differential protection relays (Transformer-, Pilot wire-, Busbar differential protection)

Buchholz and Transformer Temperature devices

Tank and frame leakage protection

Distance protection first- and accelerated- zone, where operating area is decided by impedance setting protection relays for indi-

---

## INTRODUCTION

vidual objects such as Reactor protection, Motor protection, Shunt capacitor protection

As these protection relays only operates for faults within a certain zone they are not required to be shown in the selectivity plan. Still it can be advantageous to show them in the selectivity plan to get the relation to other protection relays.

RELATIVE SELECTIVITY is when the selectivity is obtained by grading the settings (i.e. time or current) of the protection relays of several zones, all of which may respond to a given fault. These protection relays can be either time or current selective or a mixture of both.

Examples of RELATIVE SELECTIVE protection relays are

- Distance protection back-up zones
- Overcurrent protection
- Earth-current protection
- Overload protection
- Voltage protection

For these protection relays selectivity plans are made as they operate for faults in a big part of the power system and disconnect the faulty part only by grading of current, voltage and time setting. Most types of faults initiate several protection relays in above groups. For example, short circuits with earth connection can initiate overcurrent protection, earth current protection, overload protection, differential protection, negative sequence protection and undervoltage protection dependent on fault location, type of earthing and the protection system provided.

SELECTIVITY CHARACTERISTIC or SELECTIVITY PLAN.

Diagram or table showing the operating times and corresponding actuating quantities or fault positions for the selective protection relays of a network.

The purpose of the SELECTIVITY PLAN is to coordinate the relay settings so that:

- faulty equipment is tripped as fast as possible
- the least possible disturbance is obtained for healthy equipment
- a back-up protection is obtained if a main protection or its breaker fails to trip.

The selectivity plan is performed in similar way for short circuit and earth-fault protection relays. In a solidly earthed system an intercheck between earth-fault and short circuit protection's operating times must be made as short circuit protection relays often

---

## INTRODUCTION

# Setting of Protection

will operate for earth-faults as well. It is then checked that a short circuit protection, measuring phase component of fault current, will not have shorter operating time than the earth-fault protection at the same location, for an earth-fault.

of the protection relays of several zones, all of which may respond to a given fault. These protection relays can be either time or current selective or a mixture of both.

Examples of RELATIVE SELECTIVE protection relays are

- Distance protection back-up zones
- Overcurrent protection
- Earth-current protection
- Overload protection
- Voltage protection

For these protection relays selectivity plans are made as they operate for faults in a big part of the power system and disconnect the faulty part only by grading of current, voltage and time setting. Most types of faults initiate several protection relays in above groups. For example, short circuits with earth connection can initiate overcurrent protection, earth current protection, overload protection, differential protection, negative sequence protection and undervoltage protection dependent on fault location, type of earthing and the protection system provided.

## SELECTIVITY CHARACTERISTIC or SELECTIVITY PLAN.

Diagram or table showing the operating times and corresponding actuating quantities or fault positions for the selective protection relays of a network.

The purpose of the SELECTIVITY PLAN is to coordinate the relay settings so that:

- faulty equipment is tripped as fast as possible
- the least possible disturbance is obtained for healthy equipment
- a back-up protection is obtained if a main protection or its breaker fails to trip.

The selectivity plan is performed in a similar way for short circuit and earth-fault protection relays. In a solidly earthed system an intercheck between earth-fault and short circuit protection relays operating times must be made as short circuit protection relays often will operate for earth-faults as well. It is then checked that a short circuit protection, measuring phase component of fault cur-

---

## INTRODUCTION

rent, will not have shorter operating time than the earth-fault protection at the same location, for an earth-fault.

## 2. PROTECTION RELAYS SETTING

### Absolute selective protection relays

#### Distance protection

Distance protection relays are set according to the setting instruction for the specific protection. Below follows just a brief information of the general principle of setting Distance protection relays.

Distance protection relays use the impedance characteristic of the transmission line to decide the distance to the fault. Due to inaccuracies in instrument transformers, relays, line data etc. the protection is normally set to cover about 80% of the line on the first instantaneous zone. Faults up to 80% from each line end is thus instantaneously tripped by the close end relay. The central 60% of the line will be instantaneously tripped from both line ends.

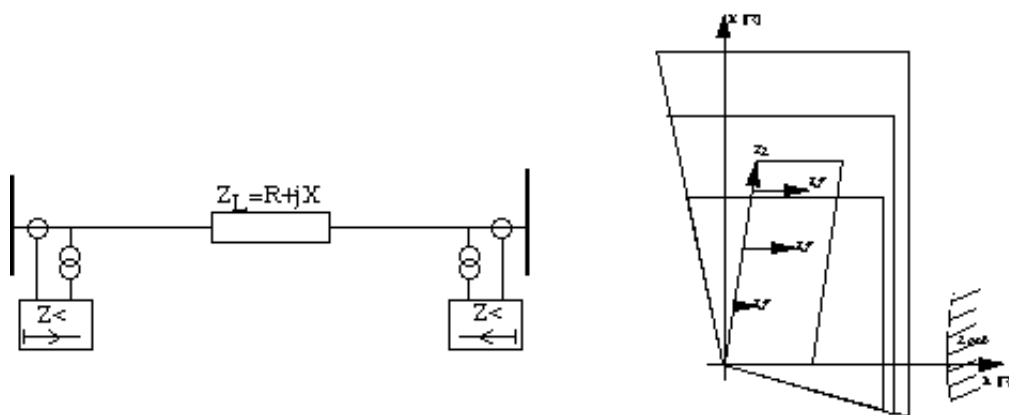

Figure 1. A Distance protection with impedance characteristic for a power line.

On higher voltages where fast fault clearance is required from stability point of view faults on the last 20% of the line are tripped instantaneously by aid of communication with remote end.

The two sides can communicate through:

---

### PROTECTION RELAYS SETTING



# Setting of Protection

- Radio link
- Power line carrier (PLC)
- Pilot wires
- Optical fibre

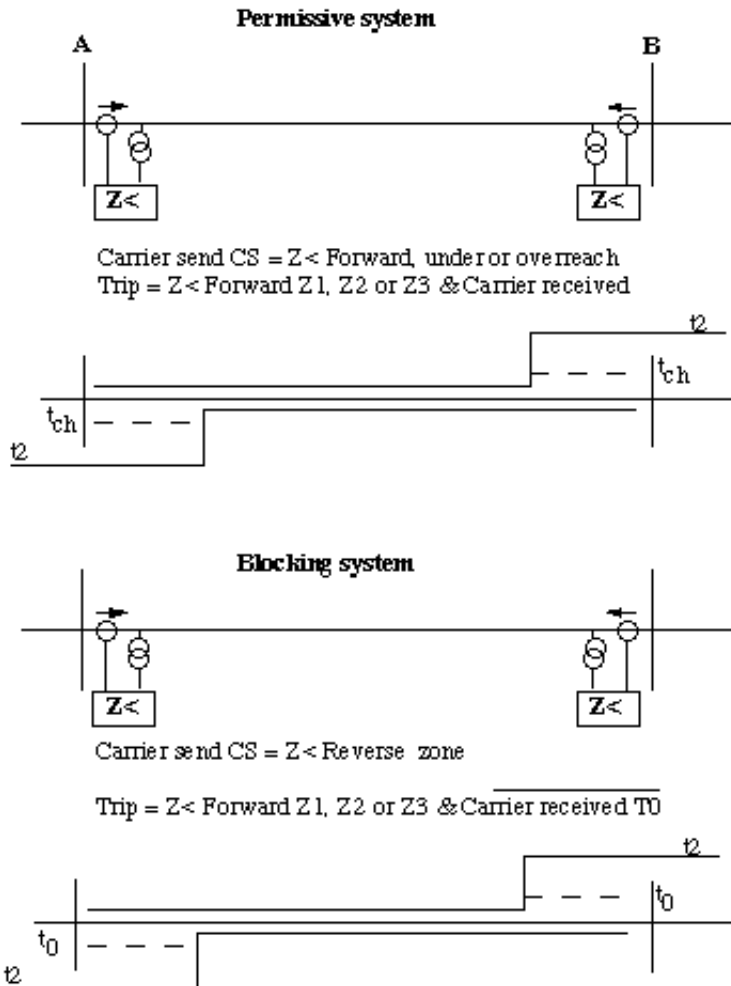

Figure 2. The principle for Distance protection relays communication.

PLC is up to now by far the most common communication link but during the 90'th the optical communication has started to become popular due to the possibility to send big amounts of information between the stations.

The two distance protection relays mainly communicate in two different modes:

- Tripping (permissive) mode
- Blocking mode

---

## PROTECTION RELAYS SETTING

In tripping mode instantaneous tripping is achieved by tripping the circuit breaker as soon as acceleration signal is received from remote end.

In blocking mode the accelerated step trips after a short time delay  $T_{ko}$  to have time to check that no blocking signal is received. When protection relays operate in blocking mode reverse looking elements are added at both ends to send blocking signal for reverse faults. Sometimes the blocking signal is sent for a criteria -Fault (from undirectional element) but not forward. This can mean that short unnecessary blocking pulses are sent for forward faults due to differences in operating time for the undirectional and the directional element. This can cause problems for relays with true directional element reverse.

#### Line impedance.

Line positive sequence reactance is normally of size 0.32-0.4 ohms/km at 50 Hz for HV - MV lines. Line zero sequence reactance is approximately 3 times the positive sequence value. Line positive sequence impedance angle is normally 70-85° and zero sequence value slightly lower.

The impedance to be covered by Distance protection is the line impedance up to the fault plus an additional arc resistance which is approximately achieved from the following formula:

$$R_{arc} = 28700 * (a+2*vt) / I^{1.4} \Omega \quad (\text{Warrington Volume 2})$$

The arc voltage has a square wave form and is of size 1–2.5 kV/m. This can also be used to estimate an arc resistance as:

$$R_{arc} = 1 - 2.5 \cdot a / I$$

where

a is arc length (m)

v is wind speed (m/s)

t is arcing time (s)

I is fault current (A)

Both formulas give approximate, similar, values.

Arc voltage as function of current according to tests at ABB. Different designations are tests at different occasions.

---

## PROTECTION RELAYS SETTING

# Setting of Protection

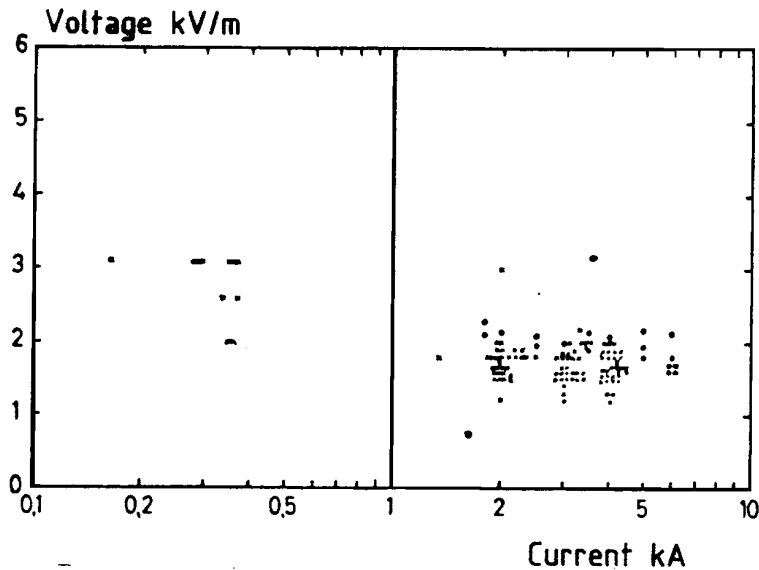

Figure 3. Distribution of arc voltage and current at many tests in ASEA.

Typical values for “a” (arc length) are:

72,5 kV 4.0 m

145 kV 5.0 m

245 kV 7.2 m

400 kV 12 m

## Tower foot resistance.

In addition to the arc resistance a tower foot resistance exists. The tower foot resistance depends on the soil resistivity, the effectiveness of the tower earthing and possible available top lines between the towers.

The primary impedance of the line is calculated to the secondary side of instrument transformers by use of the formula:  $Z_p = U_p/I_p$

$$Z_s = U_s/I_s$$

$$Z_s = Z_p * (U_s * I_p) / (I_p * U_p)$$

where

$U_p/U_s$  and  $I_p/I_s$  is the voltage respectively the current transformer ratio.

### Distance protection principle.

The required reactance and resistance reach is achieved by, in principle, two different characteristics available. These characteristics are “quadrilateral” and “mho” characteristics. It must be remembered that  $R_{arc}$  is a loop resistance whereas the distance protection relays measures the phase value.

When load is transferred on a power line with generation at both ends, an angle difference will occur between the two sources. This will give a current through the fault resistance which is not in phase with the current measured at the two line ends and will thus partly be measured as an additional reactance by the distance protection.

The situation for a fault at far line end is indicated in below figure.

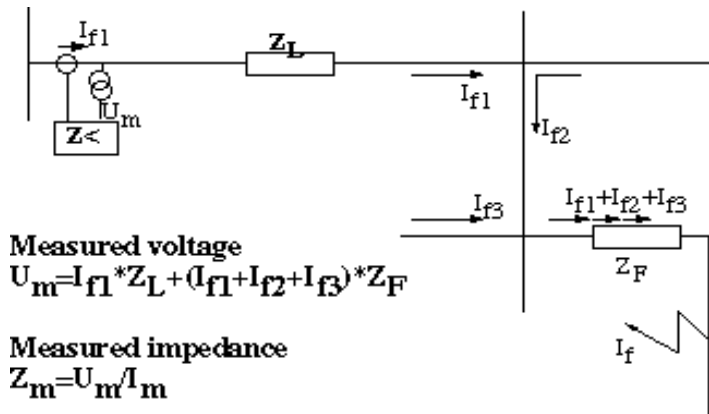

Figure 4. A fault at a remote station will due to infeed from other objects be seen as much further off than it really is.

# Setting of Protection

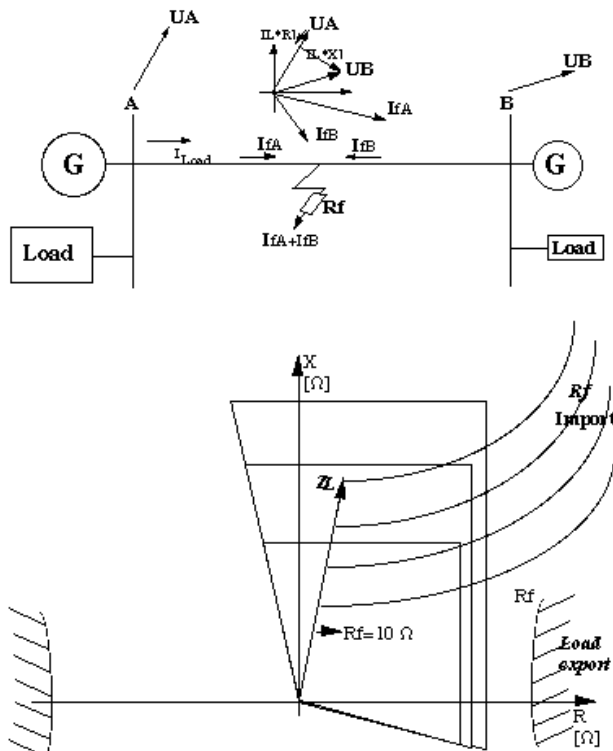

Figure 5. The Distance protection export end will overreach when a fault resistance is added in a double end infeed system. The import end will underreach.

The importing end will measure a higher reactance and thus underreach and the exporting end will measure a lower reactance and overreach. This must be compensated for, when a high resistive cover is required, with a decreased zone 1 E/F setting at exporting end.

For power lines in parallel on the same towers an additional problem occurs due to mutual coupling between the two lines. The mutual reactance can for an earth-fault be approximately  $0.5 \cdot X_{0L}$  whereas for a phase fault the value is just a few percent of  $X_{1L}$ . The mutual coupling can for earth-faults cause an overreach of normally 5-15% and need to be compensated for in setting of distance protection relays' earth-fault reach.

The second, third and possibly fourth zones are set with impedance and time to be selective to distance protection relays first, second and third zones respectively in a remote station and to the protection for other objects, e.g. transformers in remote station.

---

## PROTECTION RELAYS SETTING

At setting the back-up zones consideration need to be given the infeed of fault currents from other lines in the remote station and the apparent increase of measured impedance. Distance protection in station **A** will measure a higher voltage, and thus a higher impedance  $U/I$  than only current would have caused. This means that a remote back-up function is mostly difficult to achieve in a HV meshed system and local back-up is thus necessary.

### **Differential protection relays**

Differential protection relays are used for busbars, transformers and feeders to give instantaneous primary protection of the object. Differential protection relays measure the difference in current and are thus absolute selective protection as they will only respond to faults within a certain zone.

Examples of differential protection relays are:

- Busbar differential protection
- Transformer differential protection
- Transformer restricted earth-fault protection
- Optical line differential protection
- Pilot wire differential protection

These relays are set according to setting instructions for respective relay. Below follows just a brief information of the principles for the respective protection relay type.

#### **Busbar differential protection RADSS and REB 103.**

RADSS and REB 103 are medium impedance percentage restraint relays which are normally set to the required value at delivery.

# Setting of Protection

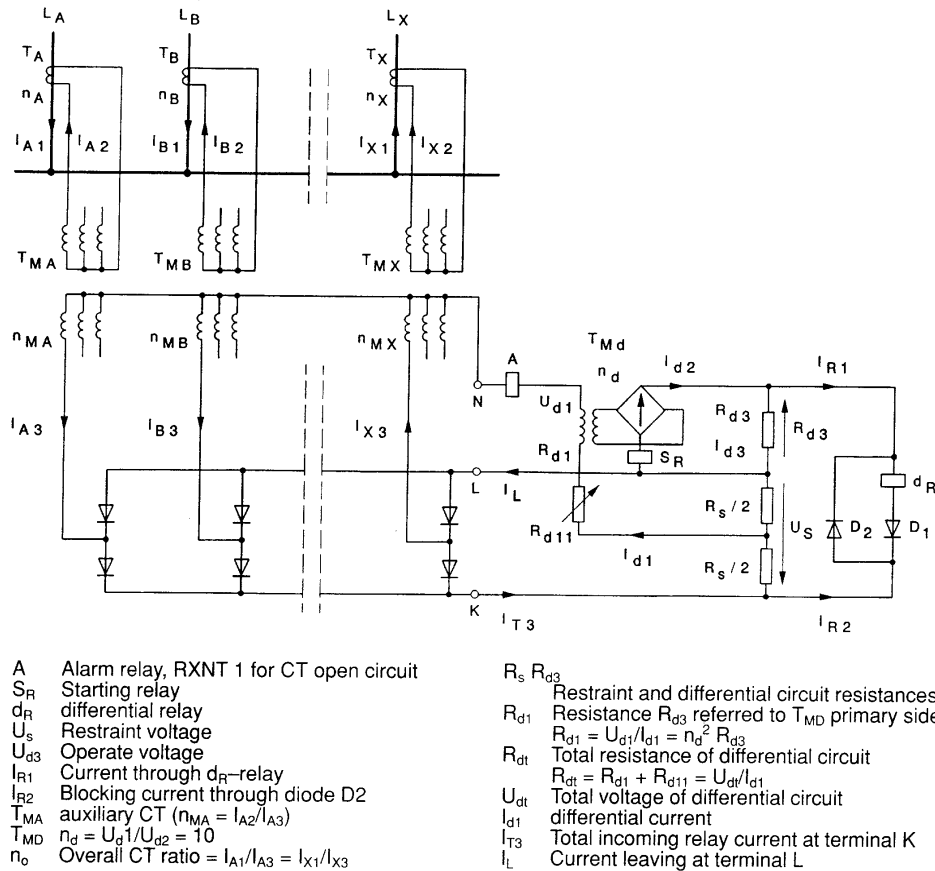

Figure 6. RADSS/REB 103 operating principle for one phase.

RADSS setting is made by adjusting the so called slope, adjusted on resistors  $R_s$ , which give the stability line of the protection and the resistor  $R_{d11}$  which gives the total resistance of the differential circuit and thus the operation level of differential relay  $d_R$ . Setting of these resistors give the operation value of the protection together with setting of the separate start relay  $S_R$ , provided to give two separate conditions for tripping. The start relay is set higher than maximum through load thus providing stability for open CT circuits under load conditions. REB 103 has fixed settings of slope and  $R_{d11}$  resistor due to the design ensuring that the relay is always suitable for all switchgears and short circuit levels.

## PROTECTION RELAYS SETTING

## Transformer differential protection

Transformer differential protection relays are percentage restraint differential relays, where operation level is in percent of measured current for external faults which gives a secure through fault stability. This is a necessary requirement for transformer differential protection relays as normal differential currents occurs due to tap changers (TC).

For internal faults the sensitivity will be in percent of the transformer rated current.

The percentage setting of Transformer Differential relays shall be: Max. TC error (from mid-end position) + Errors from CT and aux CT + 15 (margin).

A high set unrestraint stage provides extremely fast tripping for heavy internal faults. The unrestraint stage must be set above maximum through fault current and above maximum inrush current. If inrush currents are not known the following table can be used as a general guide.

Connection	Rated power	Energizing from High voltage side
-	<10 MVA	20 x
Yy	10-100 MVA	13 x
Yy	>100 MVA	8 x
Yd	-	13 x
Dy	<100 MVA	13 x
Dy	>100 MVA	8 x



# Setting of Protection

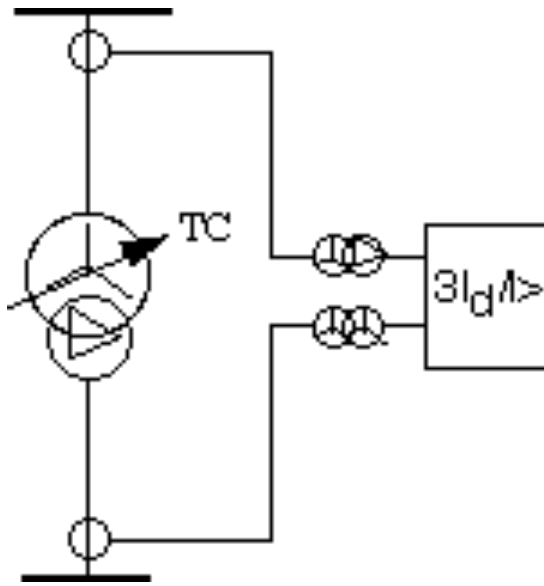

Figure 7. The differential relay for a transformer needs to have phase angle shift compensation and must have a percentage restraint to operate correctly for through faults as the tap changer percentage error will be increased at through faults. Stabilization is achieved with a summation  $(I_1 + I_2)/2$

## Restricted earth-fault protection

As earth-fault protection on solidly earthed transformers a Restricted Earth Fault protection (REF) is often provided. ABB REF type RADHD or SPAE 010 are high impedance protection, stabilized against maloperation by setting the operation voltage just above the maximum achieved voltage during external faults with one CT core fully saturated, which is the worst case. The principle is simple and will thus give fast operating relays. However the type can only be used for differential relays where the same ratio is available for all involved CT's.

A voltage dependent resistor is connected across the relay to limit overvoltages at internal faults as high voltages will be achieved at internal faults as current transformers due to the high internal resistance will immediately saturate with high CT output voltages as a result.

The required voltage setting  $U_R$  is selected as:

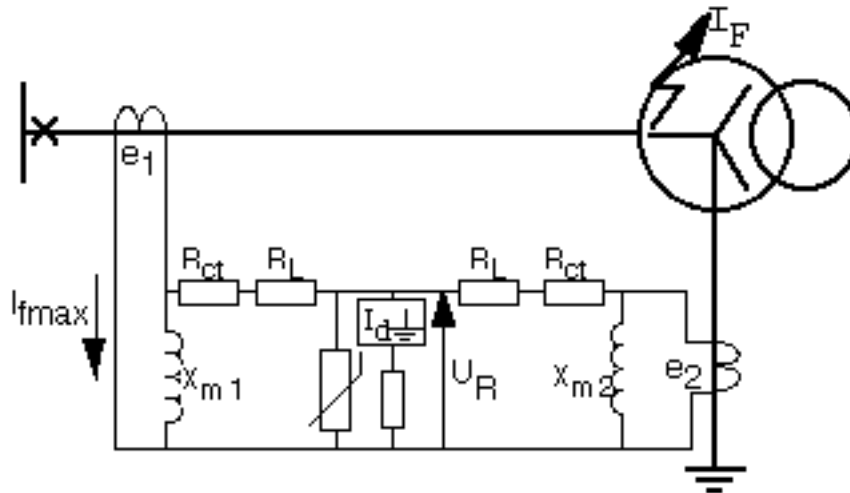

Figure 8. The connection and principle for a Restricted Earth Fault protection (REF)

$$U_R \sim I_{Fmax} (R_{CT} + R_L) \quad \text{where}$$

$I_{Fmax}$  is max through fault current at an external fault

$R_{CT}$  = Current transformer secondary resistance

$R_L$  = Maximum cable loop resistance seen from the summation point

Calculated required voltage setting will give a primary sensitivity

$I_p$ :

$$I_p = n \cdot (I_r + I_{res} + \sum I_m) \quad \text{where}$$

$I_r$  = relay current is 20 mA +24° to +45° dependent on the selected relay operating voltage

$I_{res}$  = current through voltage dependent resistor MXA

$I_m$  = sum of magnetizing current to all CT's. Angle of magnetizing current is -34° to -60° dependent on relay operation voltage, type of CT and the core data.

$n$  = current transformer ratio

Normally a restricted earthfault protection will get a sensitivity of 5-15% of transformer rated current with higher values (lower sensitivity) when lower CT ratios are provided as the influence of magnetizing current is increasing.

---

## PROTECTION RELAYS SETTING

# Setting of Protection

## **Pilot wire differential protection.**

ABB pilot wire differential protection type RADHL communicates with remote end RADHL on a pair of pilot wires. The relay has a fixed sensitivity for all types of faults, where the sensitivity differs between fault types because of the summation transformer. Another relay based on the same principle is SOLKOR Rf from Reyrolle protection.

No setting is required for RADHL if no starting relays are provided. The starting relays shall (when provided), with sufficient margin, be set above maximum load current. If no starting relays are provided the relay will operate for open or short circuited pilot wires as the sensitivity will be below rated current in most phases. Due to the summation type input transformer the sensitivity will vary with fault type.

## **3. RELATIVE SELECTIVE PROTECTION RELAYS**

### **Overcurrent relays**

Overcurrent relays are used as Back-up protection for short circuits and earth-faults for most types of objects. Overcurrent relays are relative selective protection relays where selectivity is achieved by a grading of current and/or time setting.

Overcurrent relays can be current selective, time selective or current and time selective.

### **Current selectivity**

Current selectivity means that two overcurrent relays are made selective by grading of current setting, i.e. relay at A below is set high enough not to detect faults at F3 or F4 which should be tripped by the relay at B.

---

## RELATIVE SELECTIVE PROTECTION RELAYS

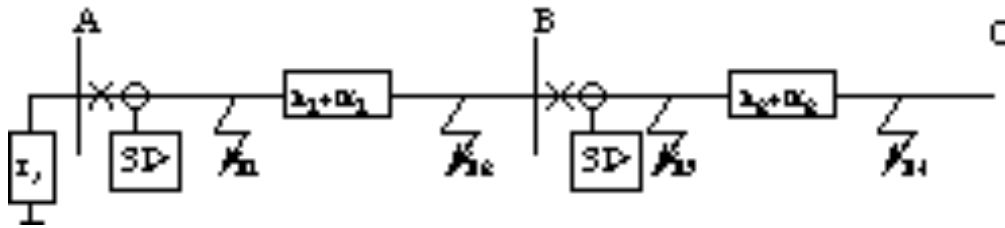

Figure 9. Current selective relays at A and B.

In practice this method can only be used when impedance  $R1 + jX1$  is of a relatively high value and thus limits fault current much more than the variation in source impedance. This is normally only the case where transformers are involved and a high-set stage with a well defined limited reach can be used.

For example an instantaneous high-set stage on relay at B above would detect faults in F3 but not in F4. A low-set delayed stage would then detect faults at F4 and further on in the system. Relay A can then be set on a higher value than relay B instantaneous stage and need thus only be time selective against relay B instantaneous stage, as current selectivity is achieved between relay at B and low set stage on relay at A.

### Time selectivity

Time selectivity is used at many occasions to get selectivity between independent time delayed current protection relays and fuses.

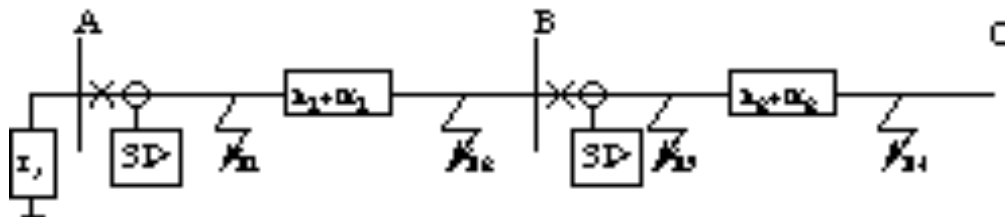

Figure 10. A Fuse and time selective overcurrent protection.

For the simple radial power system above, fuse  $tB$  will blow first. A time delay  $t1$  of 150-250 ms is then required on relay B to allow this to reset after the fuse blowout.

Relay at A must then be set selective to relay at B by setting a time  $t2$  which allows relay at A to reset for a fault successfully cleared by relay at B. Required margins are discussed below. Disadvantage with time selective protection is that times start adding and back-up trip times will be very long for a fault between

---

## RELATIVE SELECTIVE PROTECTION RELAYS

# Setting of Protection

A and B where fault current is highest as the fault is closest to the source.

## Current and time selectivity

Inverse type protection relays with Normal, Very or Extremely inverse characteristic have operating time dependent of fault current. Inverse type protection relays are simultaneously time and current selective.

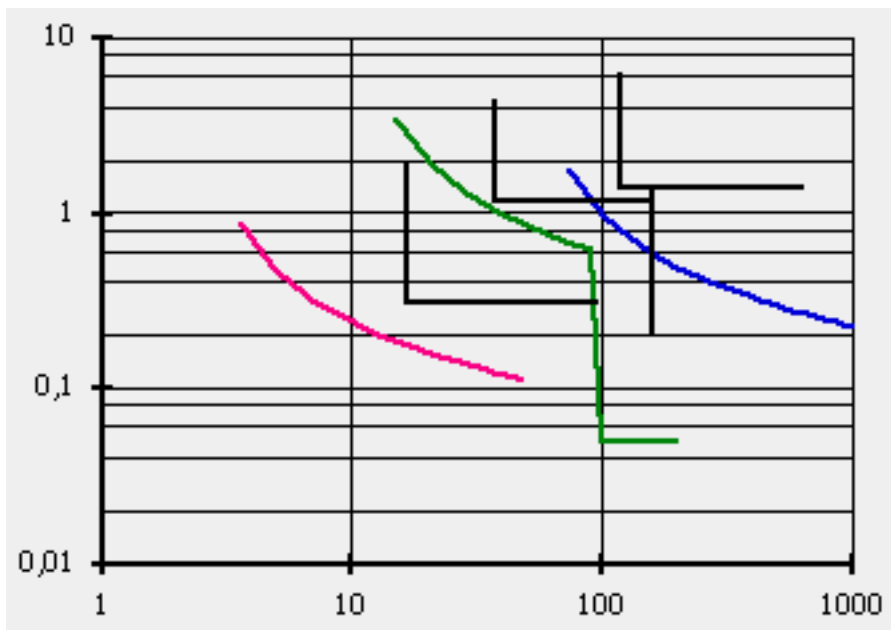

Figure 11. Inverse time delayed relays are at the same time current and time selective.

Such relays can decrease back-up tripping times in a system since operation time is decreasing with increasing fault levels. In a radial system as below where current selectivity cannot be achieved between different relays, inverse type characteristics will give an advantage as shown by the selectivity chart below. Comparison of independent (definite) time-lag relays and inverse time-lag relays:

Definite time-lag.	Inverse time-lag.
Easy to apply	Selectivity plan elaborate
Simple selectivity plan	Distribution of load and fault currents affects the tripping time.

## RELATIVE SELECTIVE PROTECTION RELAYS

Tripping time independent of the actual short circuit power.	Large variations in short circuit power may give long tripping time. Good correspondence between tripping time and short time current rating of primary equipment.
--	---

### **Short circuit protection**

When overcurrent relays are used as short circuit protection, following aspects must be considered at the setting.

Current settings shall:

- be high enough not to risk maloperation at maximum load currents.
- be low enough to give secure operation at minimum fault current (tripping requirement)

Generally one shall not use lower current setting than required to detect the occurring fault currents as this will only increase the risk of unnecessary operations.

### **Margin to load**

When selecting current setting, sufficient margin must be given for maximum load currents. The margin allows the current relay to reset when fault is tripped by an other protection and only load current is flowing again or after e.g. a transformer inrush or a motor start. For modern static relays the reset ratio can be 90-98% whereas for electromechanical relays the resetting ratio can be 70% or even less. This means that a setting of 1.3 times max load can be sufficient for a static relay, whereas an electromechanical relay requires a setting of 1.5 times max load. For H.V. side of transformers setting should be 1.3 - 2 times load current for inverse type protection relays and 3-5 times load current for definite time delayed protection relays to prevent maloperation for transformer inrush currents.

# Setting of Protection

## Margin to other protection relays

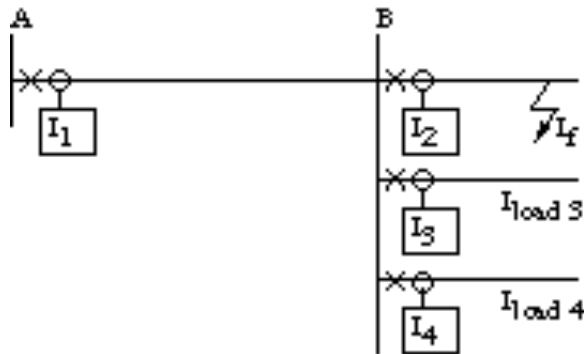

Figure 12. Setting of overcurrent relays must provide margin to maximum load current.

Further to margin to load, a short circuit protection selective to a short circuit protection in a remote station, may not detect faults not detected by the protection in remote station. This means a setting of  $I_1$ , according to fig, to:  $I_{1set} + I_{2set} + I_{3set} + I_{4set}$

where:

$$I_{2set} > I_{3set} > I_{4set}$$

It should be noted in the above formula that the load currents have a lower phase angle than fault currents, which can be used to get a low set value when problem arises with sensitivity under minimum conditions.

When directional protection relays are used, the directional element, normally with operation angle of  $60^\circ$  lagging, should be set lower than 0.25-0.5 times the current relay setting, to ensure a secure and quick operation of the directional element at operation current of the protection. The directional relay should however preferably not be operated during normal load.

The  $60^\circ$  characteristic achieved on ABB directional relays, when used as short circuit protection, gives operation for other angles  $\emptyset$  when:

$$I > I_s / \cos (60 - \emptyset).$$

---

## RELATIVE SELECTIVE PROTECTION RELAYS

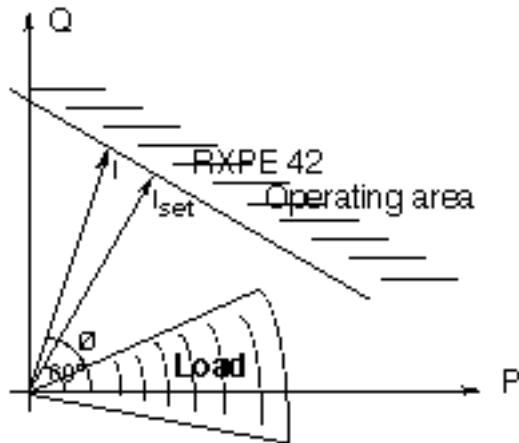

Figure 13. Directional short circuit protection, e. g. type RXPE 42 have 60-65° angle on characteristic for maximum sensitivity.

### Instantaneous stage

An instantaneous stages can be used as short circuit protection for passive loads as motors, reactors capacitors etc. with no or limited outfeed of fault current. It can be also be used for transformers, where the impedance of the transformer gives a limitation of the fault current to a, for through faults, well defined value, little dependent of the source variations.

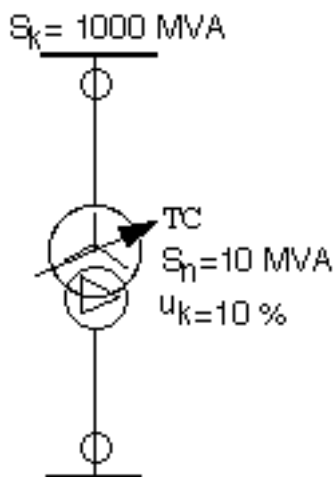

Figure 14. For a transformer an instantaneous stage can be used as the impedance of the transformer will limit the fault current at a low voltage fault.

For the above transformer a low voltage fault will have a higher fault power than:

---

## RELATIVE SELECTIVE PROTECTION RELAYS



# Setting of Protection

An instantaneous protection can thus, with a margin, be set higher than this, which means that the relay will detect faults inside the transformer, but will never reach through the transformer.

Further factors to be considered at setting of instantaneous stage for this transformer are:

- Transient overreach of current relay, i.e. overreach due to DC component in fault current. This overreach can on modern relays be of size 2-15% whereas for older electromechanical relays it can be 10-30%. Transient overreach is defined as  $(1 - K)/K$  where  $K =$  quotient between the operation value for symmetrical AC component with fully developed DC component and the operation value for symmetrical AC current without DC component.

- Differences in transformer short-circuit impedance due to tap changer step. Impedance is normally given at mid-point and can differ + 1-2% percentage units (or even more) at end taps. (Note that given percentage impedance is valid for the voltage at respective tap).

- Maximum inrush current must be lower than selected setting.

After considering these factors the instantaneous stage is normally set to cover maximum 80% of transformer and is thus a complement to transformer differential and Buchholz protection for internal faults.

## Margin to minimum fault current (Tripping requirement)

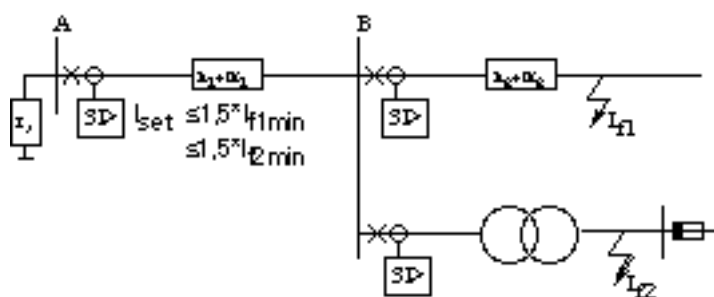

Figure 15. The minimum fault current achieved for which the overcurrent relay is required to be back-up must be detected.

When setting is calculated according to above it has to be checked that the minimum fault current, normally for a two phase fault, is sufficient to operate the relay. A margin factor to minimum fault current of at least 1.5 is required.

## RELATIVE SELECTIVE PROTECTION RELAYS

Consideration must be given to the fact that two different independent protection relays, operating on different circuit breakers, shall be able to detect the fault. This means e.g. that a fault at the far end of a distribution line or on the low voltage side of a transformer in the remote station must be detected under minimum fault current conditions.

This is often difficult to achieve, and compromises on selectivity under maximum conditions might be necessary to ensure sufficient sensitivity under minimum condition.

The tripping requirement must always have priority, i.e. lack of selectivity is preferred compared to failure to trip.

### **Margin to equipment capacity**

At primary short circuits the plant is exposed to heavy mechanical and thermal stresses. The mechanical stresses cannot be influenced by the protection relays but the thermal stresses are dependent upon fault time (time to fault clearance). Following expression can be used

$$I_k \cdot t_k = I_{12} \quad \text{where}$$

$I_k$  = Acceptable short circuit current for time  $t_k$

$I_1$  = short circuit capacity for time 1 sec.

Above formula can be used to calculate the thermal capacity for fault times in range 0.5 - 5 sec.

When setting short circuit protection relays, back-up protection tripping should be achieved before the thermal capacity of an object is exceeded.

### **Earth-fault protection**

The earth-fault protection measures the residual sum of the three-phase currents and will thus not measure any current during healthy condition. The setting of earth-fault protection relays can thus be made independent of load currents. The current settings will be dependent of the power system earthing.

### **Solidly earthed system**

In a solidly earthed system contributions to fault current is achieved from all system earthings, i.e. normally all transformer neutrals. Earth fault currents are normally not transferred to other voltage levels as earth-fault currents, except when autotransformers are involved.

---

## RELATIVE SELECTIVE PROTECTION RELAYS

# Setting of Protection

Directional earth-fault relays are often required to give a possibility of achieving selectivity, but it can also be possible by using protection relays with inverse-time characteristic and same setting on all objects. The faulty object is then tripped first since fault current always is bigger on faulty object than on the object with the highest infeed.

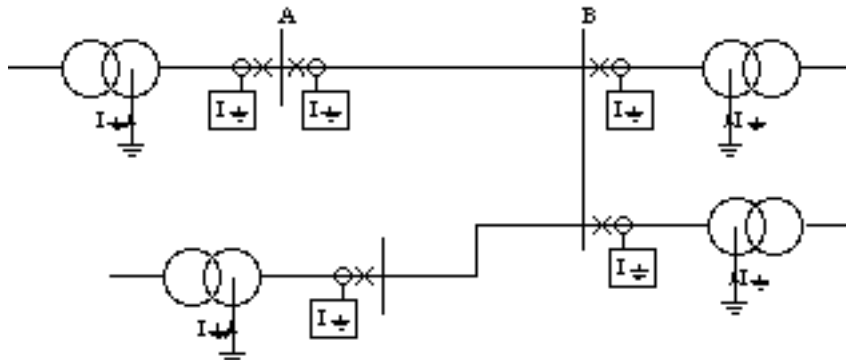

Figure 16. The earth fault protection relays in a solidly earthed system.

Protection operation level is dependent on practises in each country, - on requirement from telecom-systems - on requirement from personnel safety (due to voltage on tower structures at faults) etc. For voltages 100-400 kV the earth-fault currents required to be detected can be in range 100-400 A whereas on lower voltages the value can be as low as 50-100 A.

When power lines are not transposed the occurring unbalance current in the system will cause problems for sensitive earth-fault protection relays. Operating current should then be increased to up to 70% of maximum load.

## Low impedance earthed system

For low-ohmic earthed systems, where system earthing is a zig-zag transformer with or without a low-ohmic resistor, or a low-ohmic resistor directly in a transformer neutral, the fault current is generated from one point only and selectivity can be achieved by grading the time settings of the earth-fault protection relays at different locations.

Required current setting is normally 10 - 30% of achieved maximum earth-fault currents and the same for all protection relays in the system. A small increase of protection settings, moving to-

---

## RELATIVE SELECTIVE PROTECTION RELAYS

wards the source should be used to prevent random operation due to differences in CT's and protection relays.

As a complement a stand-by earth-fault protection can be included in the zig-zag transformer neutral. This protection is set on the continuous thermal capacity current of the zig-zag transformer and on a very long time (20-30 sec.)

### High-ohmic earthed system

High-ohmic earthed systems are earthed in the same way as low-ohmic earthed systems but with a high-ohmic resistor in the neutral. The resistor is normally selected to give fault currents of 5 - 25 A.

Current relays with definite time delay are used and selectivity is achieved by time-grading. Required current setting is normally 10 - 30% of maximum earth-fault current and close to equal for all relays throughout the system. Directional earth-fault relays, measuring the resistive component only, are often required due to in-feed of capacitive earth-fault current from healthy objects.

### Time settings

The required time interval, for time selective protection relays, with definite time delay, is decided as follows:

Relay A	Operating time measuring relay A + Time lag relay operating time A + Auxiliary relay operating time A + Breaker A total breaking time = Total fault clearance time for A
Relay B	Total fault clearance time for A - Time lag relay operating time B + Reset time measuring relay B + Retardation (overshoot) time, time lag relay B - Impulse time for auxiliary relay B + Margin between A and B = Required setting protection B

When inverse time-lag relays are used the situation is slightly changed. The required time setting will then be:

---

## RELATIVE SELECTIVE PROTECTION RELAYS

# Setting of Protection

Relay A	Operating time for time-lag overcurrent relay (at maximum fault current for which A and B relays must be selective) + Auxiliary relay operating time A + Breaker A total breaking time = Total fault clearance time for A
Relay B	Total fault clearance time for A - Retardation (overshoot) time for time-lag overcurrent relay at B at maximum fault current for which relays needs to be selective plus possible load from other objects) - Impulse time for auxiliary relay B + Margin between A and B = Required setting protection B

For selectivity between inverse time-lag relays or fuses the selectivity has to be checked for all fault currents.

Special consideration has to be given maximum fault current conditions since tripping times then are shortest

Time margin between A and B should, for short circuit protection relays, be 100 -150 ms to allow for errors and not risk any maloperation. For earth fault protection relays, where CT's are residually connected, the time margin should be increased to 150-200 ms due to the additional error caused by the summation of current transformers in the three phases.

## Overload protection

Thermal overload protection relays are often used as protection of objects such as motors, small transformers, generators and reactors with relatively large time constants and risk of overheating due to overload. Overload protection relays should be included in the selectivity plan and are set to provide protection against thermal damage of protected object.

Proposed settings: Overload protection relays are set on  $1.02 \times$  Object rated current (complying to  $1.04 \times$  Thermal content) and set with a thermal time constant not exceeding the thermal time constant of the protected object. If no temperature compensation is

---

## RELATIVE SELECTIVE PROTECTION RELAYS

provided, object time constant for highest surrounding temperature must be considered.

Note: If shunt capacitors are included in e.g. a motor circuit, the contribution of these capacitors must be considered when calculating the nominal load current.

### **Voltage protection**

Different types of voltage protection relays are used in a power system.

Neutral point voltage protection is used as a back-up protection for earth faults both on solidly, low-ohmic and high-ohmic earthed systems. Open delta winding on voltage transformer is normally selected to give 110 V secondary at a solid earth-fault. This is achieved with a secondary VT voltage of 110 V for solidly earthed system and 110/3 for high-ohmic and unearthed systems.

Normally a setting of 20V is used. When lower settings are used, e.g. for generators (normally about 5 V) or SVS (Static Var System), a third harmonic filter is mostly necessary to prevent mal-operation due to the in normal service occurring third harmonic component.

Neutral point voltage protection cannot discriminate where on a power system voltage the fault occurs and must thus be given a time delay to allow earth-fault current protection relays to trip first. Undervoltage protection relays can be used for different applications

As undervoltage protection relays for busbars with synchronous and/or asynchronous motors. Synchronous motors can at undervoltage quickly come out of synchronism and must thus quickly be disconnected. Asynchronous motors will, after an undervoltage of longer duration, at voltage recovery require new starting currents which, if many motors are connected to the same busbar, can cause operation of current protection relays on higher level in the selectivity plan. Thus asynchronous motors need to be disconnected when long voltage drops occur.

Suitable settings

$t = 0.15$  s for synchronous motors

$t = 0.4$  s for asynchronous motors

---

## RELATIVE SELECTIVE PROTECTION RELAYS

# Setting of Protection

As undervoltage protection on busbars with high priority loads, where voltage protection will separate power systems and allow high priority network to be undisturbed.

Suitable settings

$U = 80\%$      $t = 0.4 \text{ s}$

Undervoltage protection relays need not be included in the selectivity plan but must of course be coordinated. Firstly, with the system voltage profile obtained in the voltage drop calculations, to prevent tripping under conditions where the service can be maintained. Secondly, to obtain a load shedding or sectionalizing in an orderly manner.

No-voltage (Zero voltage) automatic is used to open the circuit breakers at loss of voltage and thus prepare for system restoration after a disturbance. This automatic is set to operate after all other protection relays.

Suitable setting:

$U = 40\% - 50\%$

and the protection must thus be given a time delay to allow earth-fault current protection relays to trip first.

## 4. SELECTIVITY PLAN

Preparation

Necessary informations when starting to prepare the selectivity plan are

- System diagram is needed to follow the distribution of fault and load currents.
- Maximum short-circuit currents are needed to check the rating of the relays. (It is very much needed to check the stability of absolute selective protection relays, e.g. differential protection relays.)
- Minimum short-circuit currents are needed to ensure that no current relay is set too high to operate (tripping requirement) under minimum fault condition.
- Maximum service currents are needed to check that no protection relays trip erroneously during permissible service conditions.

---

### SELECTIVITY PLAN

The maximum service currents and their order and duration for different objects can be:

Transformers: Inrush current about 5-20 • In during the first period, decreasing 20% per period.

Motors: Starting current 1.5-8 • In lasting up to 25 seconds (differs a lot depending on type of load).

Busbars: Reacceleration current to all supplied objects of the currents (motors) after a net disturbance of short duration. Size and duration can be obtained through voltage drop calculations.

- Relay characteristics are needed to decide upon the margins between consecutive protection relays. The margins are influenced by protective relay accuracy, setting accuracy, temperature range, auxiliary voltage variations, reset value and “point of no return” for the relays.

- Breaker characteristics, especially the total breaking time, are needed to calculate required margin between the consecutive protection relays time setting.

Step by step instruction

1) Prepare yourself by assembling and calculating: single line diagram, system rated data, fault powers/currents plus relay block diagram and relay characteristics on log-log paper (50 mm scale factor). Inrush currents for transformers, start currents for motors etc. are also assembled as indicated under 3.1 above.

If different voltage levels are involved, which is normally the case, it's advantageous to use MVA (kVA) instead of currents in the selectivity plan. After selecting MVA (kVA) setting for each relay the setting is calculated to primary and secondary current for the object.

Use 50 mm scale factor log-diagrams, semi-transparent, for your selectivity plan. When only definite time protection relays are used semi-transparent paper and relay characteristics are not needed.

2) Start with settings of overcurrent protection relays and then calculate settings of earth-fault protection relays. Selectivity must be checked for faults on all objects.

3) Indicate time and MVA (kVA) scale on semi-transparent paper. Same time scale as on relay characteristics should preferably be used.

4) Start with the object lowest in the selectivity chain, where the highest setting is foreseen. Calculate current and time setting, or select time constant (on inverse type relays), for the relative se-

---

## SELECTIVITY PLAN



# Setting of Protection

lective protection required to operate first for a fault on the object where selectivity is checked. See section 2.2 for setting calculation.

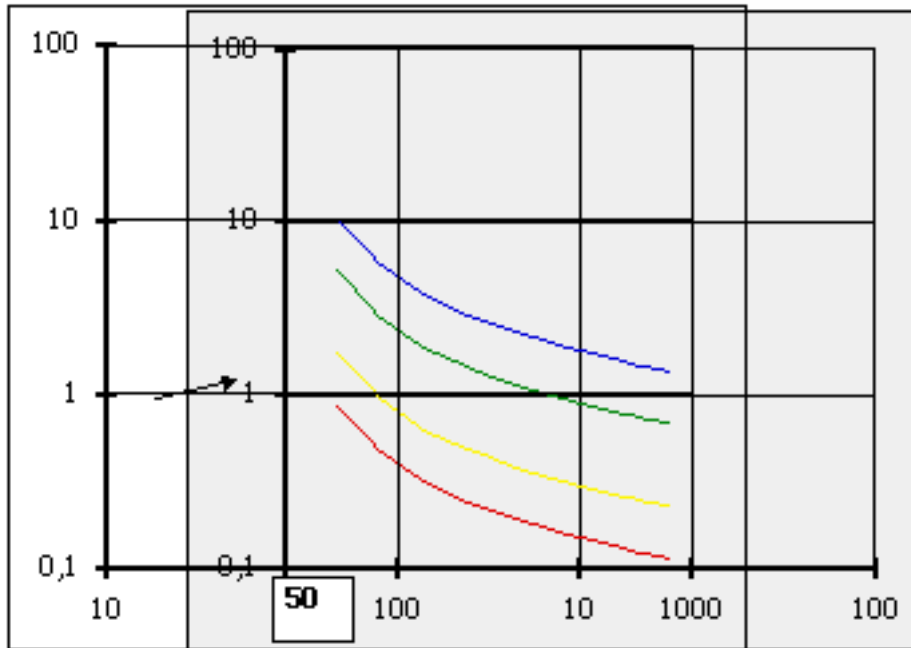

Figure 17. Set the first relay to 50 A by putting 50 A matching 1 on the relay characteristic sheets.

5) Put the semi-transparent log-log paper over the selected relay curve and check that 1 sec. fits to 1 sec. and that selected MVA setting fits to 1 (set current/power) on the semi-transparent and the relay characteristic paper respectively. Draw the selected relay characteristic on the semi-transparent paper.

Example of setting 50 MVA,  $k = 0.05$  sec.

6) Calculate required current setting on next relay to operate according to instructions under section 2.2 and find a suitable time setting by trying with different  $k$  values and checking time and current margin for all fault currents. Doing this it is advantageous to add information about maximum and minimum fault current/power at/through different objects on the semi-transparent log-log paper.

Relay setting 150 MVA  $k = 0.1$

---

## SELECTIVITY PLAN

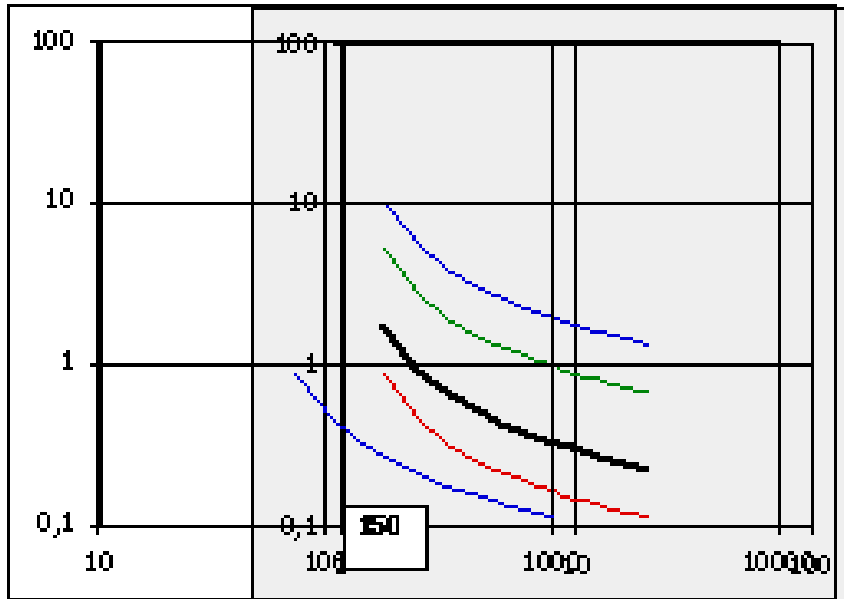

Figure 18. Set next relay to 150 A by putting 150 A matching 1 on the relay characteristic sheets. Draw the required curve giving sufficient time margin for all currents achieved.

7) Repeat the procedure for all further protection relays required to be selective.

8) Check that the back-up tripping times does not exceed thermal capacity of the objects

9) Repeat the same procedure for earth-fault relays.

Check for faults at different locations, that short-circuit protection relays will not give shorter tripping times and thus disturb the selectivity for earth-faults. Doing this it must be remembered that an earth-fault protection measures neutral current whereas short-circuit protection measures phase currents.

### **Absolute selective protection relays in the selectivity plan**

It can sometimes be advantageous to indicate instantaneous unit protection relays in the selectivity plan to check that relative selective protection relays are not interfering.

A differential protection is simple to indicate as it will operate for certain current levels only and provide a fixed operating time of 20-40 ms.

---

## SELECTIVITY PLAN

# Setting of Protection

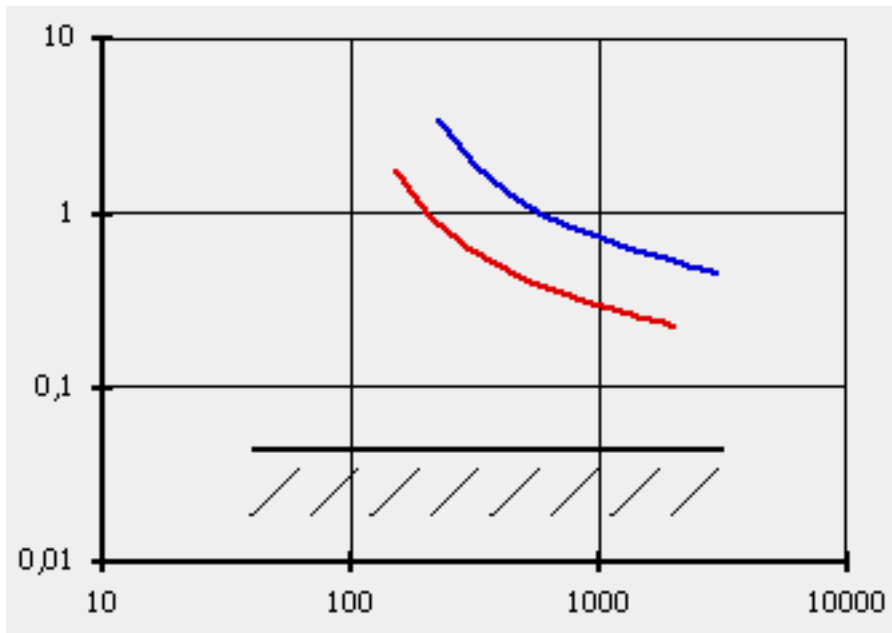

Figure 19. A Differential relay can be indicated in the selectivity plan with the operating time and a current range starting from maximum sensitivity.

An impedance protection is more difficult to indicate as the operation is dependent of the quotient  $Z = U/I$  which means dependence of the power  $S = U_n (Z_S + Z_L)$  where  $Z_S$  is source impedance and  $Z_L$  is distance protection setting for each zone.  $U_n$  is rated line to line voltage. Representation of a distance protection in a log-log diagram will be as below.

---

## SELECTIVITY PLAN

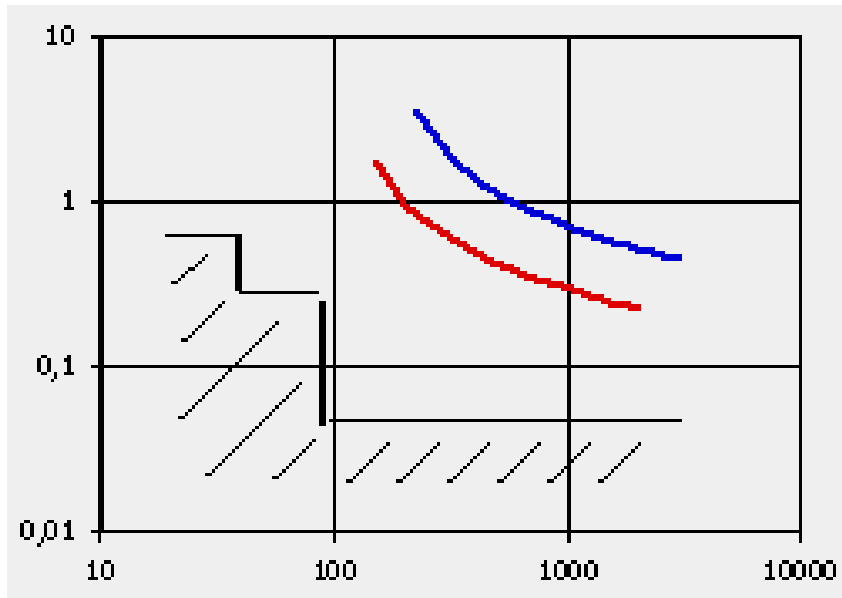

Figure 20. A Distance protection with three stages can be indicated with the time stages and impedance stages recalculated to MVA or current at nominal voltage and possible some other voltage level as a range for each stage.

### Special problems at setting of protection relays

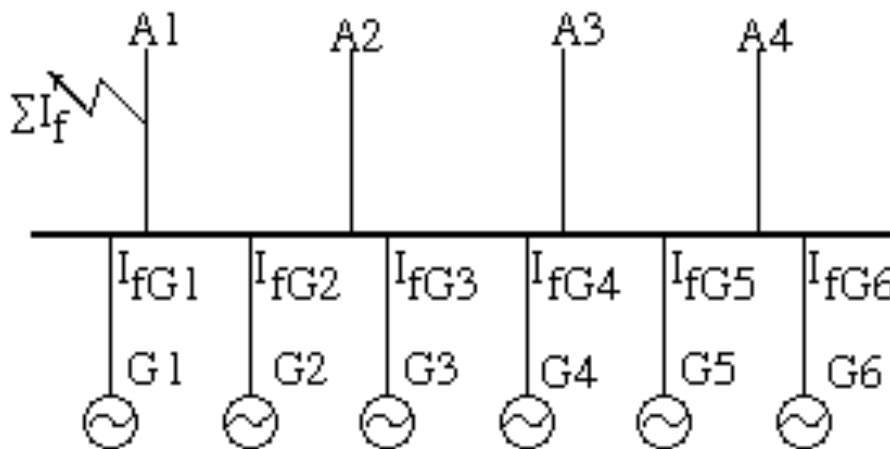

Figure 21. A generating station with many infeeds to a fault on an outgoing feeder.

It should be noted that for a system with many infeeds such as H.V. grid systems, the currents through relays of different locations can be quite different, which can give a situation like this. In this case the same setting can be used on all relays with maintained selectivity since current through faulty object always is biggest. The same situation also appears for earth-current relays in

---

## SELECTIVITY PLAN

# Setting of Protection

solidly grounded systems with many grounding points. Also for one of many generator feeders a similar situation occurs.

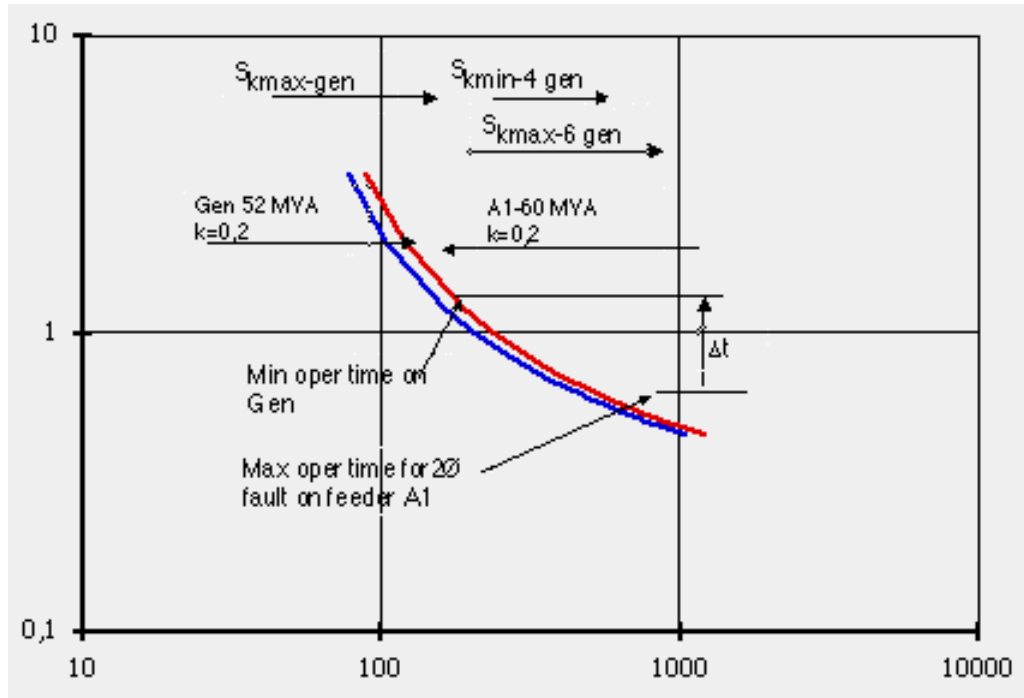

Figure 22. Similar settings can give selectivity due to differences in fault currents at different locations.

---

## SELECTIVITY PLAN

## 5. SETTING EXAMPLES

Setting of short circuit protection relays in a distribution network. For a power system the settings of short circuit protection relays shall be calculated. The network is a distribution network as shown in below figure.

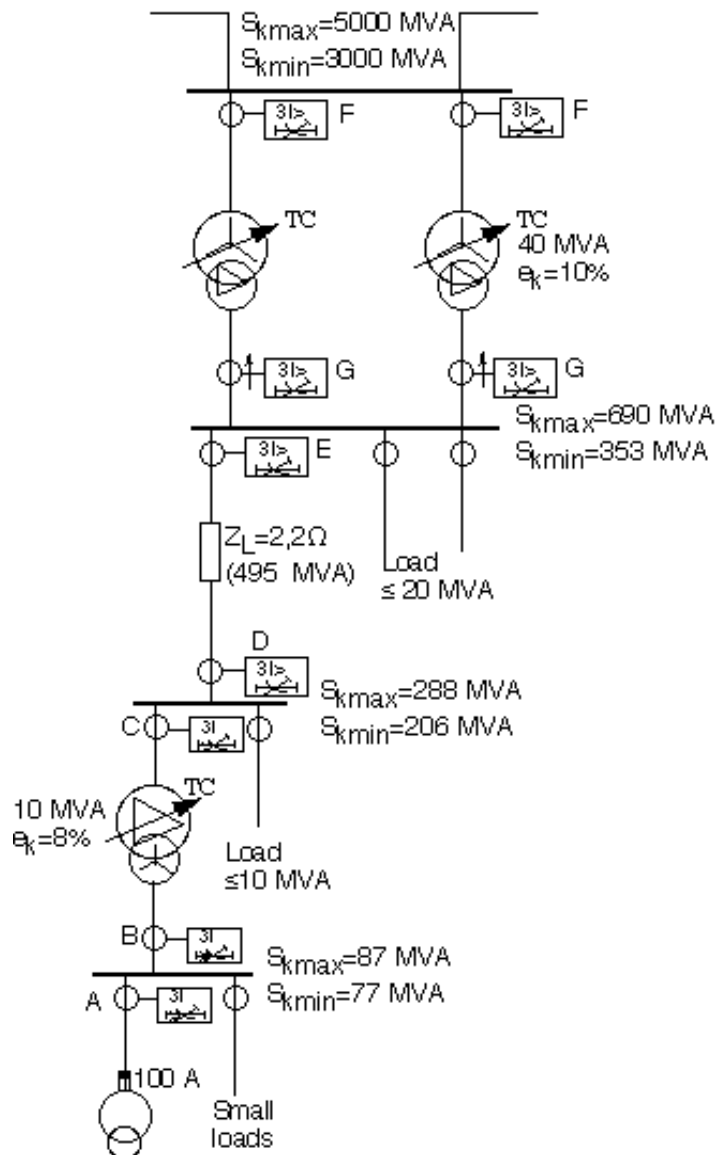

Figure 23. The selectivity plan must cover setting of all the protection relays in the network.

Start to-

- 1) assemble data
  - a) One-line diagram see fig.
  - b) Rated data see fig.

---

### SETTING EXAMPLES

# Setting of Protection

c) protection equipment. All relays are of type RXIDK 2H with normal inverse characteristic. Recovery (Overtravel) time is < 80 ms. Directional relay is type RXPE 42 with definite time delay 0.2-3 s.

d) Calculate fault power at all locations. Max and min values are required. See fig.

e) All breakers have tripping time 60 ms

Fuse is of type SHB. 100 A = 1.9 MVA

2) Draw 100 A fuse characteristic on the log-log paper.

3) Calculate setting of short circuit protection A. Check required setting with achieved selectivity. Note that A protection is only required to cover 11 kV faults as a fuse is a “secure break point”. Fault clearance time of fuse is 10 ms. A setting 15 MVA  $k=0.05$  gives selectivity. Time margin 140 ms at max fault current on 11 kV ( $t_1$ ).

4) Calculate required setting for relay B. Relay B must be selective to relay A allowing for load on other objects on 11 kV busbar.

$$I_{B \text{ set}} \geq I_{A \text{ set}} + I_{\text{LOAD}}$$

$$\text{Set} = 20 \text{ MVA}, \quad k=0.15.$$

5) Calculate required setting of relay C.

Same setting of inverse type element can be used as for relay B as transformer any way always is disconnected and on an achieved selectivity will delay backup tripping 300-400 ms for fault within transformer and for faults higher up in system. As transformer is D/Y a phase to phase fault on low voltage side will have only 0.866 p.u. of current when H.V side has 1.0 p.u. in one phase and 0.5 p.u. in the other two phases. This must be compensated for by selecting a little higher setting. Set 25 MVA,  $k=0.15$ .

6) Select setting of instantaneous element of relay C.

Maximum fault power fed through the transformer for a low voltage fault will be 87 MVA. Select a setting of 120% of max current plus margin for transient overreach. RXIDK 2H transient overreach for instantaneous step is < 18%.

$$\text{Set } 1.2 \cdot 1.18 \cdot 87 = 125 \text{ MVA}.$$

7) Select setting of relay D.

$$D \text{ must be given a current setting } I_{SD} > I_{sc} + I_{\text{LOAD}}$$

A setting  $I_{SD} = 30 \text{ MVA}$  gives a sufficient margin not to operate

---

## SETTING EXAMPLES

during normal load, and also fulfils above requirement since fault and load currents are not in phase, and as load transmitting possibility is limited because the voltage has collapsed. A check with different k values and setting 30 MVA shows that  $k = 0.2$  is a suitable value.

8) Select setting of relay E.

In this case relay E is required to be selective to relay D although disconnecting the same line. Only the breaker closest to the fault may trip as stations are unmanned with quite a distance between. E relay is set to  $I_{SE} = 34$  MVA which gives margin for differences in current transformers and relays. Time curve  $k=0.3$  gives selectivity to relay D. Time margin 0.3 sec. with max fault current at station B.

9) Setting of relay F delayed stage.

Relay F shall be set on  $I_{Fset} \geq I_{Eset} + I_{LOAD}$  (other object) and  $> 1.4-1.5 \cdot I_n$  for the transformer. Note that at maximum service two transformers are connected in parallel. Fault current will also be split up between two transformers at maximum service but at minimum service only one transformer is feeding.

Set  $I_{Fset} = 60$  MVA  $k=0.4$  which gives a suitable curve.

10) Select setting of relay F instantaneous stage.

Instantaneous stage is set as under item 6.

Set  $I_{FInst} = 1.2 - 1.18 \cdot 345$  MVA = 490 MVA.

11) Set directional short circuit protection relays G. Protection G are intended to operate for fault current fed from parallel transformer for a fault in one transformer low voltage bay. Relays must operate selective to relay F for all occurring fault current fed from parallel transformer (Maximum 690/2 MVA)

Protection has an operating angle of  $60^\circ$  and can be set on rated power of transformer or even below if required.

Set  $I_{Gset} = 40$  MVA  $t = 0.4$  sec. which gives time selectivity to protection on high voltage side (F) for all fault currents.

12) Setting is now completed and all settings can be calculated in current for the appropriate voltage level and then to secondary current for setting of the relay. Minor adjustments might be necessary if settings are not steplessly. The required time margin between selective relays is checked according to item 2.2.4.

Required time difference will be (simplified).

This is fulfilled for all steps.

---

## SETTING EXAMPLES



# Setting of Protection

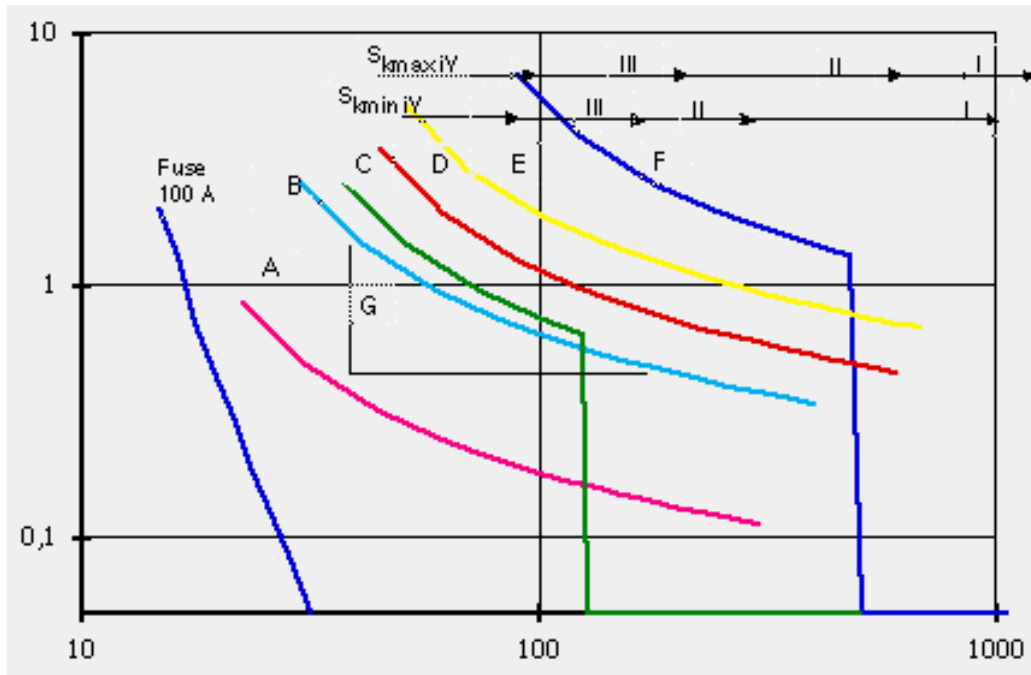
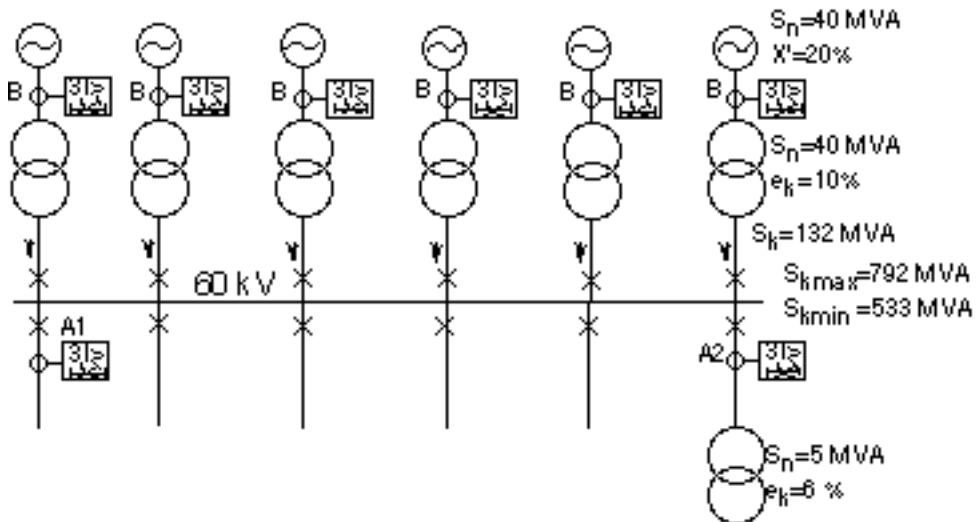

Figure 24. The selectivity plan will have all relays in the network indicated and the time margin must be checked for all selective relays. The sensitivity for back-up protection to fulfil tripping criteria must also be checked.

## SETTING EXAMPLES

## Setting of short circuit protection relays in a generation network

To illustrate use of inverse type characteristics we shall set the protection relays the net as shown on fig.



- 1) Assemble data.
  - a) One-line diagram see fig.
  - b) Rated data see fig.
  - c) protection equipment. All relays are type RXIDK 2H with “normal inverse characteristic”. Recovery (overtravel) time < 80 ms
  - d) Calculate fault power for busbar fault.

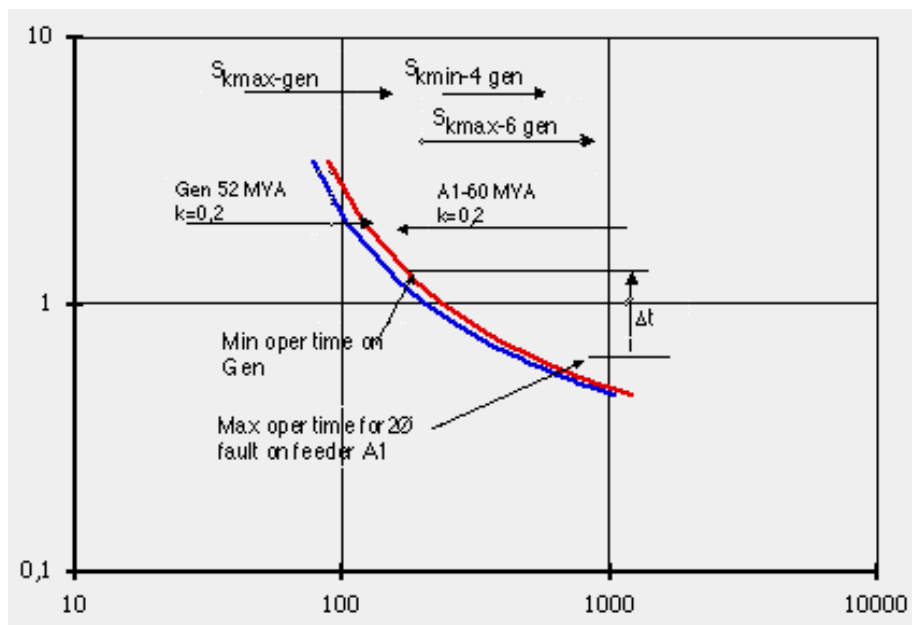

Figure 25. The selectivity plan shows that selectivity is achieved with similar settings due to the differences in fault currents.

## SETTING EXAMPLES

# Setting of Protection

Max and min value required. Min generation is 4 generators. e) Breakers tripping time is 60 ms.

2) Draw selected settings of outgoing object on log-log paper. Only highest setting need to be shown i.e. draw AI setting.

3) Max operating time for fault on outgoing feeder A1 is about 0.75 sec. i.e. min operating time on each generator must be higher than 750 ms + C.B. (60 ms) + RXIDK recovery (80 ms) + margin i.e. > 1.0 s.

Current setting on generator is set with margin to max load.

Select 52 MVA (1.3-In)  $k=0.2$  which gives a suitable curve.

It is noted that although generator setting is lower than for outgoing feeders selectivity is still achieved because of the big difference in fault current for each object compared to the total current.

Setting of Back-up earth fault protection relays in a transmission network

RXIDG 2H inverse characteristic.

Back-up earth fault protection relays shall be set in system as shown in figure.

1) Assemble data

a) One line diagram see fig.

b) protection equipment. All relays are ABB type RXIDG 2H with specially designed inverse characteristic for back-up earth-fault protection relays in a H.V. meshed system.

c) Calculate fault current contributions from the different objects under different occurring service conditions.

d) Set RXIDG 2H operation level on required level for system level. Select 120 A primary. Time curve is fixed and will always give selectivity if biggest infeed is less than 80% of fault current on faulty feeder. Inverse time characteristic has a definite min level which is selected to allow for single-pole tripping and autoreclosing. Set this level to 1.2 sec.

---

## SETTING EXAMPLES

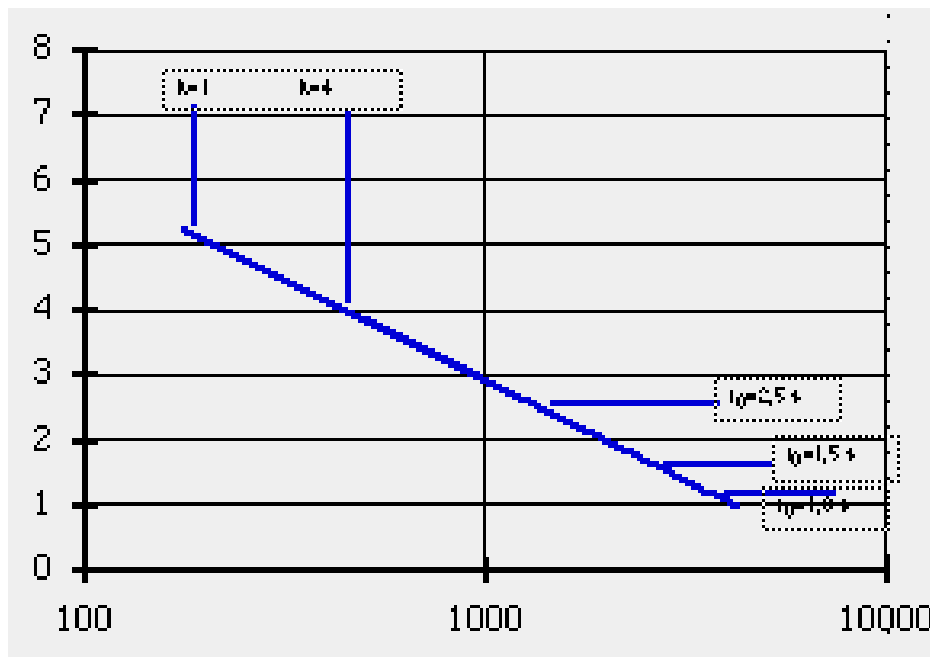

Figure 26. The logarithmic inverse characteristic will give selectivity if the biggest object fault current contribution is lower than 80% of the faulty object fault current.

### Final conclusion

The setting of time and current selective relays is a quite complicated task. The preparation is very important in order to make a good selectivity plan. It must be remembered that an incorrect setting can cause big disturbances in the power network with high costs (missing earnings) as a result. The work should thus be performed carefully and the future should be predicted as far as possible to ensure that selected settings are suitable also when network is extended and changed.

Modern tools are today available to perform a selectivity plan, but they must always be used with human control, where all results are checked and confirmed by an experienced relay engineer, as tools are never better than the programmer of the tool. The same philosophy is adapted when using a tool as described above. The tool is just taking away the need for semi-transparent paper and the work of drawing the characteristic.

---

## SETTING EXAMPLES

# Sub-divided Systems

## 1. SUB-DIVIDED PROTECTION SYSTEMS. WHY?

The single failure criteria can be fulfilled with a protection system including back-up protection. The back-up protection must be able to detect all primary faults detected by the primary protection, primarily intended to clear the fault. There are two different ways of arranging back-up protection:

Remote back-up is the common way of arranging back-up in a distribution network. This means that the back-up protection is available at another breaker. Remote back-up is normally achieved by a time grading where the back-up protection is given higher time setting than the primary protection.

Local back-up is used when remote back-up is difficult to achieve or when time grading to achieve selectivity is not acceptable due to thermal limits or network stability reasons. Local back-up means that at the breaker location, a second protection relay detecting the same faults as the primary relay, is included. The two systems are operating in parallel on the same breaker.

The principle with local back-up is mainly used in the HV transmission network where the fault current is fed from many different directions.

When the local back-up is operating with same time and principle as the primary protection, the protection system consists of redundant protection.

## 2. SUB-DIVIDED PROTECTION SYSTEMS. HOW?

As mentioned above the task of the protection system is to clear the primary faults and the abnormal service conditions. The total fault clearance chain consists of different parts as shown in below figure.

---

### SUB-DIVIDED PROTECTION SYSTEMS. WHY?

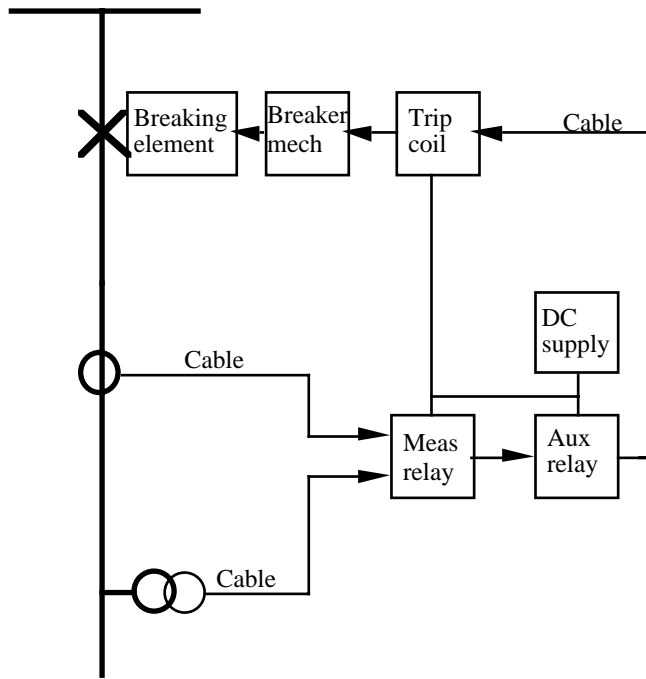

Figure 1. The different parts of the fault clearance chain

As noted the secured clearance of the fault includes correct behavior of many different elements, none of which is allowed to fail. All sections can thus be said to have the same importance which puts stringent requirement on the plant design.

When remote back-up is used the fault clearance is secured with two different breakers including protection relays capable of detecting same faults. The important care needed to be taken in such cases is to ensure that the same DC supply, or at least battery feeder, is not used for two protection relays where one is being back-up to the other.

When local back-up, with or without redundant protection, is used the fault clearance chain will normally be as shown in figure 3.

---

## SUB-DIVIDED PROTECTION SYSTEMS. HOW?

# Sub-divided Systems

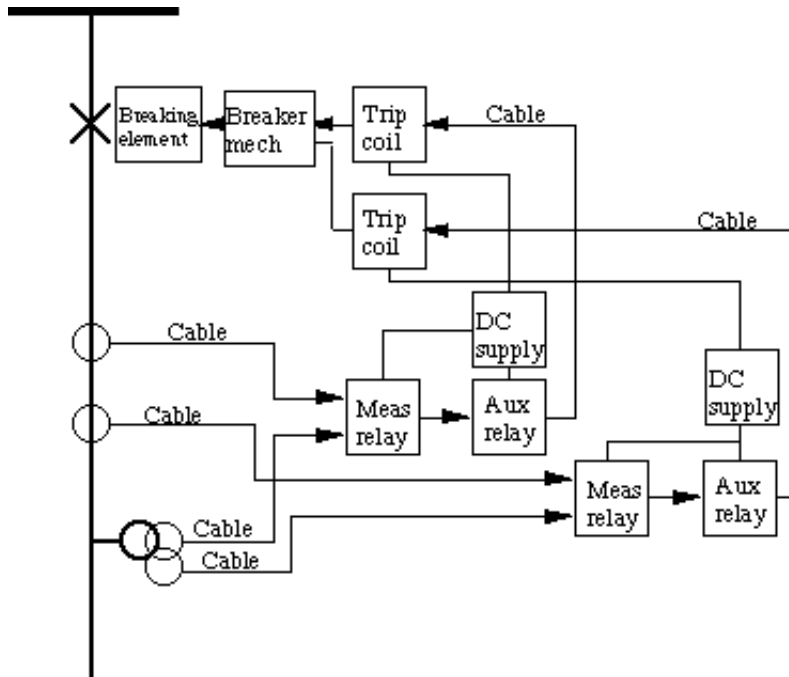

Figure 2. Fault clearance chain at redundant protection systems

A common practices used at redundant systems is:

- Different cores are used on the instrument transformers.  
*Duplication of apparatus is very unusual due to the high cost involved and the very good operating statistic.*
- The circuit breakers are not duplicated of cost reason. *However duplicated trip coils are used.*
- The DC supply is separated as far as feasible.  
*For HV system the use of redundant batteries is common practices.*
- Physical separation is performed as far as realistic.  
*Often cables are laid in different cable ducts.*

As the circuit breakers are not duplicated, the failure of a breaker to operate will mean that the fault is not cleared. In order to clear the faults the surrounding breakers are then required to operate instead. For applications where local back-up is required due to failure of “remote” protection relays to detect the fault, a breaker failure relay is thus essential. The breaker failure relay measures the fault current still fed through the breaker after expected tripping and will then trip all surrounding circuit breakers.

An example of the protection system including redundant protection, for a HV line, is shown in Enclosure 1 under Protection Line.

---

## SUB-DIVIDED PROTECTION SYSTEMS. HOW?

## **Instrument transformer circuits**

The instrument transformers are normally not duplicated but only provided with different cores for the two sub-systems. The redundant protection systems are connected to different cores and any mixture, where one current transformer core is feeding both sub-systems, should be avoided. This also includes feeding another type of protection e. g. the Busbar protection, when this is included in the other sub-system, from the same core.

Any current loop feeding more than one panel should be avoided due to the risk of open circuits at terminating point or in the terminal itself (specially when this has a disconnectable link).

Both sub systems are normally connected to the same CT connection box. Physical separation in different CT boxes is normally not possible.

For voltage transformer circuits a common way is similarly to use separate secondary windings for the two sub-systems. In some cases two windings are not available and in such cases the circuits should be separated on different fuse groups in the marshalling box. This is normally a fully acceptable solution due to the high availability proven for voltage transformers.

## **Physical location in panels**

- When sub-divided systems are used the physical location in panels of the protection relays and of necessary auxiliary relays is of main importance.
- The common practices on the highest voltages is to use different panels for sub 1 and sub 2 equipment. The reason for physical split-up is to prevent problems due to e. g. cable fire or mechanical damage in a panel.

However in some cases where the sub-systems takes small place it must be considered acceptable to put the equipment for both sub-systems in the same panel.

The risk of cable fire or other mechanical damage which could influence two systems in the same panel must be considered negligible. Problems with mixture of circuits and mistake at erection, commissioning or maintenance must be considered and steps taken to ensure that this will not happen.

---

## **SUB-DIVIDED PROTECTION SYSTEMS. HOW?**



# Sub-divided Systems

Two different objects in the same panel will give similar problems and need careful split-up of the equipment both on panel front and inside the panel to prevent service and maintenance personnel from doing mistakes.

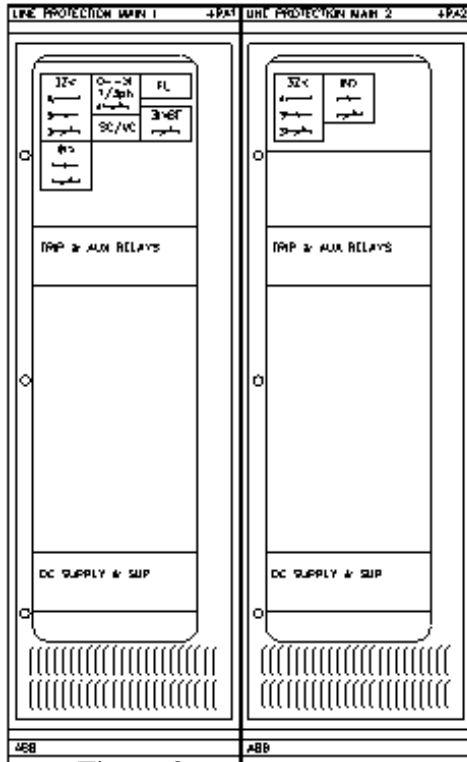

Figure 3

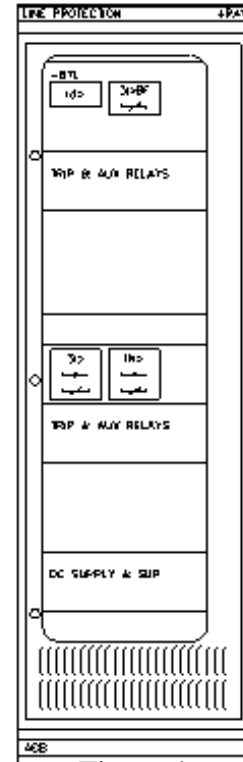

Figure 4

*Figure 3. The front layout of a relay panel for a HV line where the sub-systems are with panel separation. The equipment included is as shown on block diagram for a HV line, see Line protection section.*

*Figure 4. Arrangement of two sub-systems in a common panel.*

From above follows that an important part at panel design is to clearly indicate to which object the equipment belongs. When sub-divided systems are used the sub-system belonging shall also be clearly indicated. This includes clear separation of the equipment and clear labelling of different sections, also on separation parts between sub-systems or objects. The separation must also be performed inside the panel by physically separating the terminal groups for the different equipment in the panel.

---

## SUB-DIVIDED PROTECTION SYSTEMS. HOW?

A terminal numbering system allowing for visibility of sub-system and circuit belonging is then an important part to simplify and ensure a correct design. ABB SUB/T has set up rules for terminal numbering in sub-divided systems.

Please refer to Control System structure section for this numbering system.

All equipment used in the protection system and also other auxiliary relays connected to the same battery system, or fuse groups, shall be grouped together and clearly labelled.

Remember to include the equipment for closing, interlocking etc. which is located in the protection panel.

### **DC supply**

The DC supply is one of the key parts at arranging back-up protection both when local and remote back-up are used. Many trip failures causing large equipment damage have been caused by DC failures.

The principle which must be followed is to ensure that the Main and the Back-up protection are not fed from the same DC supply. The level of independence can be different. On the highest voltage completely redundant systems are used which then includes two separate batteries, two to three battery chargers etc.

For simpler applications it can normally be considered sufficient to separate the battery main distribution in two sections and feed the main and back-up protection from different sections or at least different main fuses on the battery distribution.

A commonly used principle is to minimize the sub 2 DC distribution as much as possible. Preferable it should only be used in relay panel and on breaker trip coil.

An example showing the design of a DC system with redundant batteries is available in Appendix 1.

---

## SUB-DIVIDED PROTECTION SYSTEMS. HOW?

# Sub-divided Systems

## 2.1 ARRANGEMENT OF TRIP CIRCUITS

Another main part of the protection system is the trip circuits. A failure of the trip circuit will of course give a failure to trip the breaker. As mentioned above the breaker itself is not duplicated of cost reason and the only realistic means of improving dependability is to use two trip coils on the breaker. This will cover problems with DC supply, the wiring or the coil but will not give any advantage for mechanical problems.

Duplication of the trip coil is today possible on all EHV, HV and MV circuit breakers and to a low cost.

Another mean of further improving dependability of the trip circuit is to include trip circuit supervision relay/s. These can supervise the circuit from the relay panel to the breaker and will detect open circuit or loss of DC supply. The common principle used is to feed a small current through the circuit. The current path will be broken at open circuit or DC problems and an alarm is given.

It should be ensured that all wiring is included in the supervision. Specially care must be taken when some trip contacts are provided in a different panel which can happen for transformer bays or generator bays.

## 2.2 EXCHANGE OF INFORMATION BETWEEN THE TWO SUB-SYSTEMS

The main principle used when sub-divided systems are utilized is to avoid exchange between the two systems. As far as possible the systems shall operate completely independent of each other. This gives the highest total security as problems at design, maintenance etc. due to human or equipment failure are avoided.

In most cases however some signals are required to go to other sub-system. The most common signals are:

- Start and block of auto-recloser.

---

### SUB-DIVIDED PROTECTION SYSTEMS. HOW?

*Auto-recloser is normally not duplicated due to speed problems with two units and due to the minor consequence a failure to auto-reclose will mean. A number of signals will be required between the sub-systems to give auto-reclose also when only the protection in the other sub-system operates.*

- Start of Breaker failure protection

*Similar to Auto-recloser the Breaker failure function (BFR) is not duplicated in redundant systems. The reason for this is however completely different. The Breaker failure function has extremely high requirements on the security against unnecessary trippings and duplication will mean an increased dependability but the security will decrease. As the risk of breaker failure statistically is very low the security aspect is most important and the BFR function is only provided in one of the systems, normally in the primary protection system.*

The exchange of information between the systems should be handled with outermost care to prevent problems e. g. when maintenance is done in one of the systems.

Interface relays should be put inside or on front on a preferable separate labelled area in one of the panels only.

The terminals should also be clearly indicated inside the panel in order to simplify the finding and opening of the correct terminals when the sub-systems are to be separated.

Interface relays should be separately mounted and preferably in sub 2 panel. This will limit the distribution of the sub 2 DC supply as mentioned above.

---

## SUB-DIVIDED PROTECTION SYSTEMS. HOW?

# Sub-divided Systems

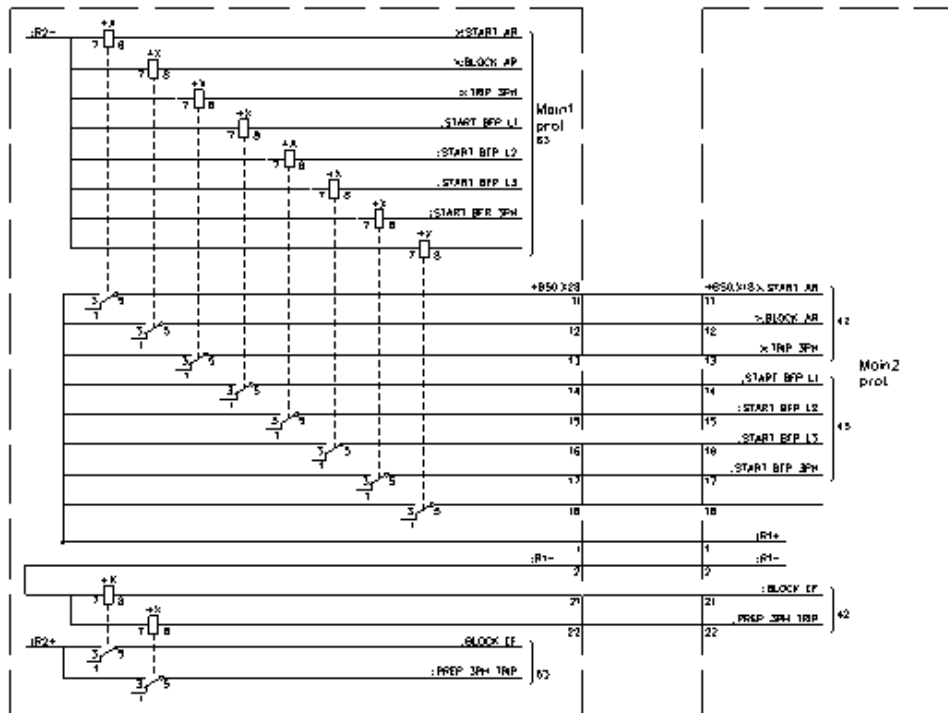

Figure 5. Sub 1-Sub 2 interface for a HV overhead line

An example of how an interface unit for sub 1-sub 2 interface can be arranged for a HV line is shown in Figure 5. The example is same as on Block diagram in Enclosure 1 to Protection Line section and on the panel layouts Figure 3 and 4. The terminal numbering used is based on the standard terminal numbering system, refer to section Control System Structure.

## 2.3 CABLING

A common requirement for sub-divided protection system is to use different cable ways for the two systems. Often this requirement is limited to e. g. use of different cable ladders in the same cable duct. The sub 1 and Sub 2 signals must under all circumstances be in different cables.

## 2.4 ALARMING AND TESTING

The protection system is designed according to “single failure criteria”. This means that the “single failures” in the protection system must be discovered within a reasonable time. An alarming of secondary system faults is thus of same importance as the alarming of primary faults. The alarms must be connected to give remote alarms as well.

Some faults are not detected by the supervision equipment. To detect these faults regular system testing and post fault disturbance analysis are of vital importance.

Testing and analyzing of protection system behavior gives a possibility to detect “hidden faults” such as failure in some parts of a protection relay or problems with selected settings or with the used measuring principle.

A correctly performed alarming and regular testing of the protection system will ensure that faults in the secondary circuits are discovered and the fault clearance at an occurring primary fault secured.

## 2.5 GENERAL ASPECTS ON SECURITY AND DEPENDABILITY

As mentioned the reason for redundant systems is to ensure the local back-up i. e. secure fault clearance according to the “single failure criteria”. This is fulfilled with the two independent systems where one system can fail in any component of the fault clearance chain but the fault clearance is still secured.

Adding extra equipment and/or cross tripping etc. to cover even more than a “single failure” should be avoided as the security and the dependability are in opposition and an increased dependability will always lead to a decreased security.

More equipment, a more complicated and advanced protection system, cross tripping, where protection relays in each systems are connected to trip also in the other system, shall be strictly

---

### SUB-DIVIDED PROTECTION SYSTEMS. HOW?

# Sub-divided Systems

avoided. The simple reason is that security is always lost and the total reliability is dependent on both security and dependability.

Most unwanted trippings in sub-stations are proven to be dependent of human mistakes. A basic principle at protection system design should thus be to design the protection system simplest possible but fulfilling the single failure criteria.

The design shall be such that human mistakes are avoided and this includes mistakes during all stages of a project from basic design where guide-lines are set, through detailed design stage, erection, commissioning and maintenance.

It must be remembered that the life-time total cost of a plant is to a big part including cost for service and maintenance and also cost for availability. The cost of an unnecessary tripping can be much higher than the initial cost increase to include some extra equipment. Unnecessary equipment and complications should thus be avoided.

---

## SUB-DIVIDED PROTECTION SYSTEMS. HOW?

## 2.6 CONCLUSION

Means to ensure a reliable redundant protection system are:

- Limit the mixing of equipment from different objects or from different sub-systems in the same panel. When mixing, clearly label the equipment on the front and also within the panel to indicate object or sub-system belonging.
- A standardized terminal numbering system simplifies design and minimizes mistakes at panel design and erection and commissioning.
- Avoid exchange of information between sub-systems as far as possible. When signals between the sub-systems are required, indicate where these circuits are located both on the front and inside the panel. A separate terminal group should be used.
- Keep design as simple as possible. Do not include extra equipment to cover more "if's". Extra equipment can increase dependability but will always mean a reduced security and thus a reduced reliability.

Appendix 1 A redundant battery system Block diagram



# Sub-divided Systems

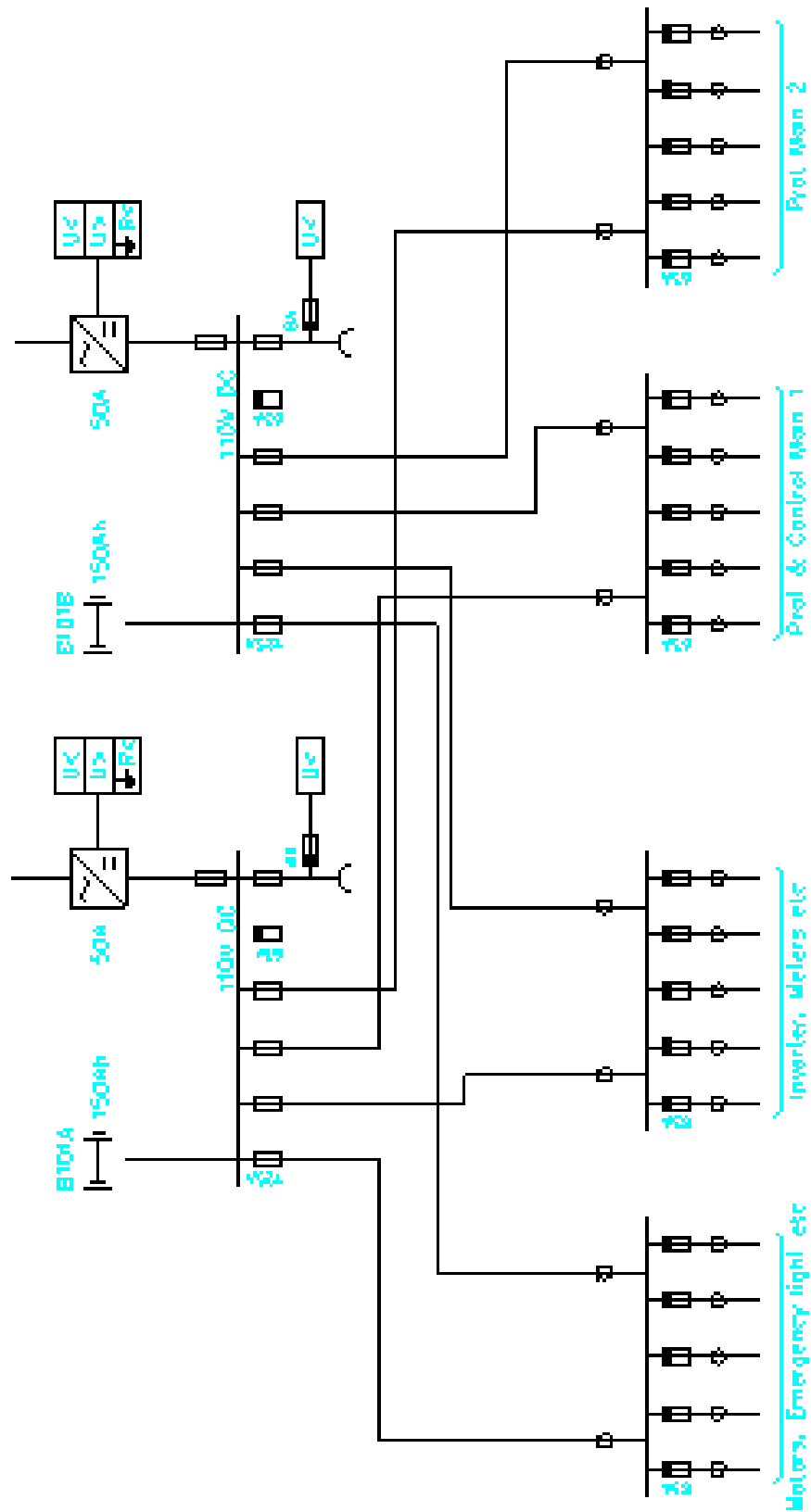

## SUB-DIVIDED PROTECTION SYSTEMS. HOW?

---

## SUB-DIVIDED PROTECTION SYSTEMS. HOW?

We hope you have found the content of interest and of use for your work.

The protection application is an area where primary system knowledge is of vital importance and where the technology of the secondary equipment is going through a very fast change with micro-processor technology giving many advantages such as:

- Self Supervision minimizing your maintenance
- Internal intelligence allowing improved functions for service values checking, event listing and disturbance recording which gives a much improved reliability of the protection system if correctly used for post-fault analysis.
- Few spare parts and thus low spare part cost due to the hardware platforms for each products where different software is provided to give the different functions.
- Improved protection functionality where the numerical technic with possibilities to store pre-fault conditions etc. gives a possibility to improve the protection functions.

**BOOK No 6**

Revision 0

# **PROTECTION APPLICATION HANDBOOK**

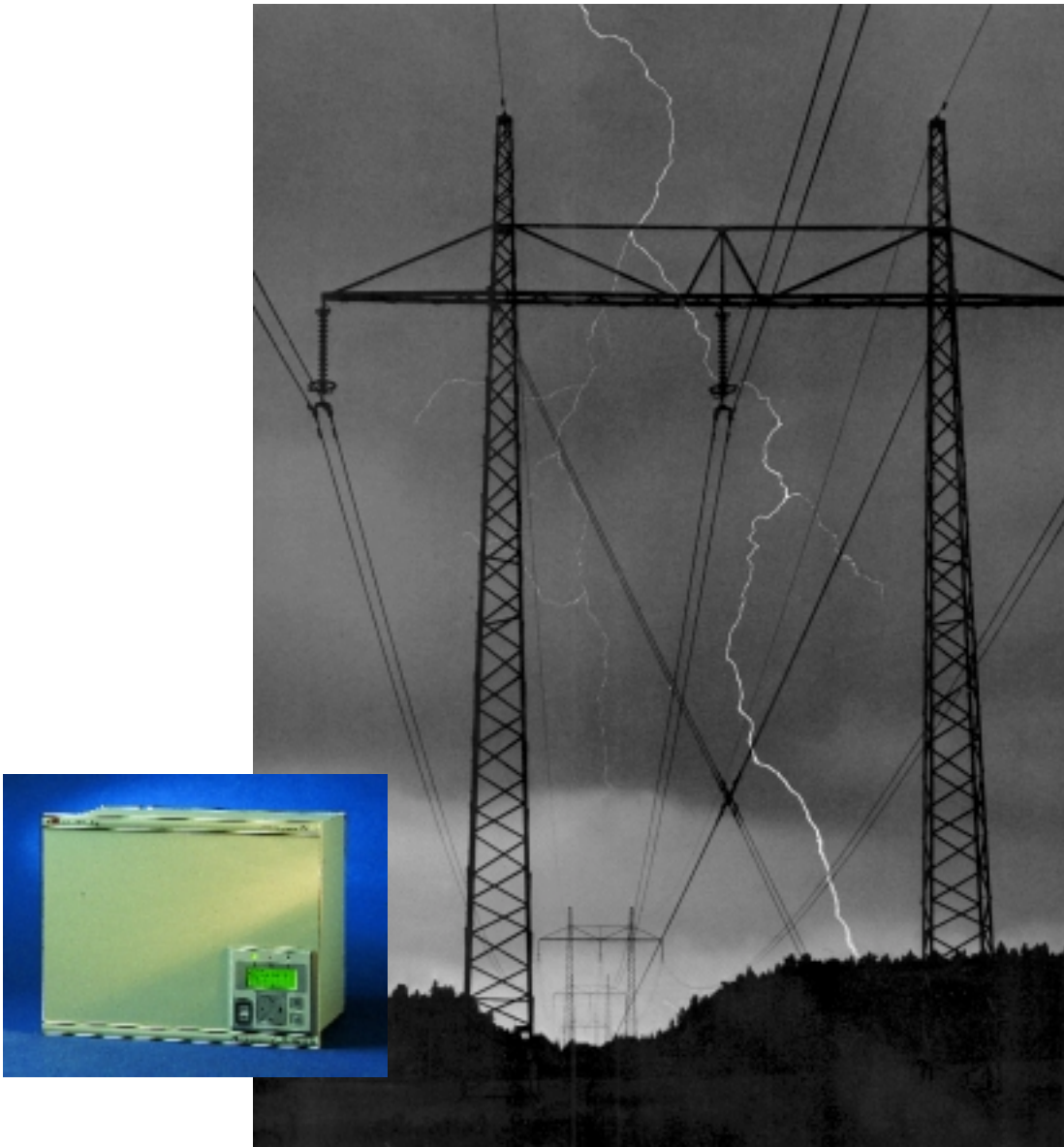

# **ABB**

**ABB Transmission and Distribution Management Ltd**  
BA THS / BU Transmission Systems and Substations  
P. O. Box 8131  
CH - 8050 Zürich  
Switzerland

**BU TS / Global LEC Support**  
C/o ABB Switchgear AB  
SE - 721 58 Västerås  
Sweden